

# TUTORIAL - PARALLEL CIRCUITS

NAME: \_\_\_\_\_

Please note the following requirements in relation to tutorial work -

- All tutorial work is to be completed on ruled A4 pad paper, with multiple pages stapled together. Write on one side only of the answer sheets.
- All work is to be completed in ink.
- In the case of multiple choice type questions, the question number and answer letter are to be written on the answer sheet.
- All relevant equations and working are to be shown in the case of calculation type questions.
- All diagrams are to be drawn using appropriate drawing instruments. Drawings are not to be freehand.

## Section A

In the following statements one of the suggested answers is best. Place the identifying letter on your answer sheet.

1. In a parallel circuit the supply current is equal to the:
    - (a) total power multiplied by the supply voltage
    - (b) sum of the branch currents
    - (c) supply voltage divided by the resistance of any one branch
    - (d) ratio of the branch currents
  
  2. Connecting resistors in parallel produces the same general effect as:
    - (a) increasing the temperature of a metallic conductor
    - (b) increasing the cross-sectional area of a conductor
    - (c) increasing the length of a conductor
    - (d) decreasing the conductance of a conductor.
  
  3. When three  $10\Omega$  resistors are connected in parallel to each other, the voltage drop across each is:
    - (a) one third of the supply voltage
    - (b) supply voltage divided by 10
    - (c) equal to the supply voltage
    - (d) supply voltage divided by 30.
-

4. The lowest value of resistance in any parallel combination of resistors is always:
- (a) equal to the equivalent resistance of the combination.
  - (b) less than the equivalent resistance of the combination.
  - (c) dependent on voltage and current for its resistance.
  - (d) greater than the equivalent resistance of the combination.
5. Twenty five resistors each with a resistance of  $100\ \Omega$  are connected in parallel with each other. The equivalent resistance of the combination is:
- (a)  $100\ \Omega$
  - (b)  $2500\ \Omega$
  - (c)  $4\ \Omega$
  - (d)  $25\ \Omega$
6. A parallel circuit is defined as a circuit with:
- (a) more than one resistor
  - (b) more than one current path
  - (c) only one current path
  - (d) more than one supply voltage
7. If an extra parallel connected resistor is added to a circuit, the equivalent resistance of the circuit will:
- (a) increase
  - (b) remain unchanged
  - (c) decrease
  - (d) cause the applied voltage to increase.
8. The voltage in a parallel circuit:
- (a) is the same in all parts of the circuit
  - (b) decreases through the circuit from resistor to resistor
  - (c) greater than the supply voltage
  - (d) increases with increase resistance.
-

9. If one resistor in a parallel circuit of three resistors becomes short circuited, the circuit current will:
- (a) remain constant
  - (b) decrease to zero
  - (c) decrease by the value of current in the shorted branch
  - (d) increase to a large value
10. The power dissipation of a parallel circuit is equal to the:
- (a) sum of the power dissipation of each branch
  - (b) product of the power dissipation of each branch
  - (c) difference of the power dissipation of each branch
  - (d) power dissipation of each branch divided by the number of branches

**Section B:**

Blank spaces in the following statements represent omissions. Write the appropriate information.

11. Two electrical instruments whose readings can be combined to determine the power dissipation of a circuit are the ..... and .....meters..

Voltmeter , Ammeter

12. When resistances are connected in parallel, the equivalent resistance of the group is always, .....than that of the smallest individual value of resistance in the group.

less

13. The current taken by a parallel circuit is equal to the ..... of the currents in the separate branches.

sum

14. The voltage across parallel branches of a parallel circuit is.....the supply voltage.

equal

15. To lower the equivalent resistance of a circuit, further resistance may be connected in ..... with the original circuit.

parallel

16. The total power taken by a parallel circuit is equal to the .....of the powers taken by the individual branches.

sum

17. Two lamps are connected in parallel. The filament of the first lamp open circuits, the second lamp would .....

be the same

Questions 18 to 17 relate to figure 22.

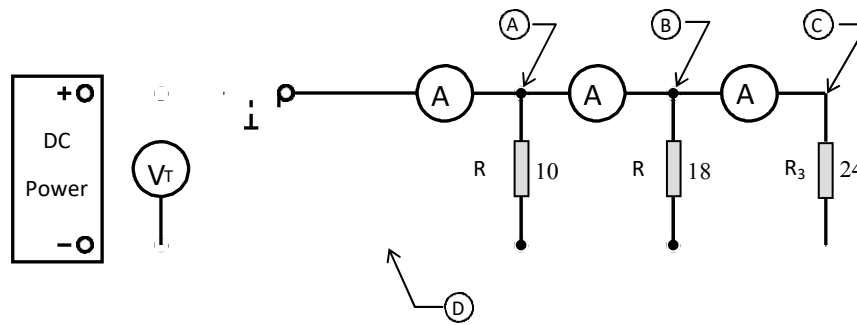

figure 22.

18. The reading on ammeter  $A_1$  will be ..... than the reading on ammeter  $A_3$ .

**greater**

19. If the value of the resistor  $R_2$  was decreased, the equivalent circuit resistance would .....

**decrease**

20. With the switch in the open position, the voltage across the switch would equal .....

**Supply voltage**

21. Using the negative terminal of the power supply as a reference, complete the following statements

(a) the voltage at point A would ..... the voltage at point C

**greater**

(b) the voltage at point D would be ..... than the voltage at point B

**greater**

(c) the voltage at point C would be ..... than the voltage at point D  
less

(d) the voltage at point B would.....the voltage at point C.

**greater**

22. The power dissipated by resistor  $R_2$  would be ..... than the power dissipated by resistor  $R_1$ .

**greater**

23. If resistor  $R_1$  became open circuit, the equivalent resistance of the circuit would be .....

**greater**

24. If resistor  $R_3$  became short circuit, the circuit current would ..... and the power dissipation would .....

**very high , very high**

**SECTION C See Teacher Calculation**

The following problems are to be solved with the aid of a calculator. Answers are to be correct to two (2) decimal places. All equations and working are to be shown.

25. Determine the equivalent resistance for the circuit shown in figure 2. ( $51.16\Omega$ )

26. Determine the current flowing in  $R_1$ ,  $R_2$ ,  $R_3$

and

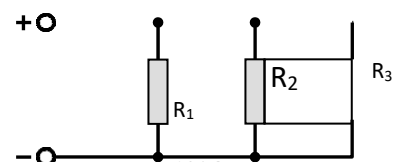

from the power supply in the circuit of figure 2 if the supply voltage is 12V. (0.1A, 0.08A, 0.055A, 0.235A)

figure 23.

27. Determine the supply voltage for the circuit of figure 23 if the total current flowing in the circuit was 0.586A (30V)

28. For the circuit of figure 24 determine the -

- equivalent resistance. (5 Ω)
- current in each branch (19.2A, 11.5A, 15.33A)
- supply current (46A)
- power dissipated by each branch (4408W, 2645W, 3526W)
- total power dissipation (10580W)

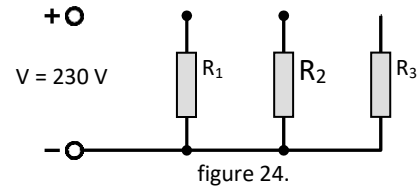

figure 24.

29. A circuit is made up of two resistors in parallel and has an equivalent resistance of  $15.23\ \Omega$ . If  $R_1$  has a resistance of  $25\ \Omega$ , determine the resistance of  $R_2$ . (39 Ω)

30. For the circuit of figure 25 determine -

- equivalent resistance. (4.29 Ω)
- applied voltage. (60V)
- current in  $R_2$  and  $R_3$  (3A, 6A)
- supply current. (14A)
- power dissipated in each branch. (300W, 180W, 360W)
- total power dissipated. (840W)

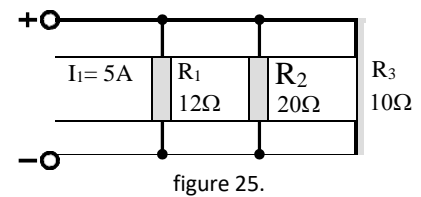

figure 25.

# TUTORIAL - SERIES PARALLEL CIRCUITS

NAME: \_\_\_\_\_

Please note the following requirements in relation to tutorial work -

- All tutorial work is to be completed on ruled A4 pad paper, with multiple pages stapled together. Write on one side only of the answer sheets.
- All work is to be completed in ink.
- In the case of multiple choice type questions, the question number and answer letter are to be written on the answer sheet.
- All relevant equations and working are to be shown in the case of calculation type questions.
- All diagrams are to be drawn using appropriate drawing instruments. Drawings are not to be freehand.

## Section A

In the following statements one of the suggested answers is best. Place the identifying letter on your answer sheet.

1. The voltages in the parallel section of a series-parallel circuit:
    - (a) are affected by the circuit equivalent resistance
    - (b) are difficult to determine
    - (c) are the same across the parallel components
    - (d) decrease through the circuit from component to component
  
  2. If one resistor in the parallel section of a series-parallel circuit goes open circuit, the circuit power dissipation will:
    - (a) remain constant.
    - (b) decrease.
    - (c) increase.
    - (d) decrease to zero.
  
  3. The power dissipation of any circuit:
    - (a) equal to the sum of the power dissipation of each resistor.
    - (b) equal to the product of the power dissipation of each resistor.
    - (c) equal to the supply voltage squared times the circuit equivalent resistance.
    - (d) depends on the circuit arrangement.
-

4. In the circuit of figure 12, the supply current is equal to the:

- (a) value of branch currents.
- (b) product of the branch currents.
- (c) sum of the currents in each resistor.

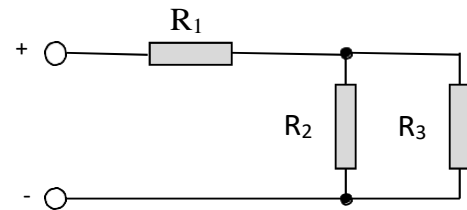

figure 12.

**(d) sum of the branch currents.**

5. If the resistor  $R_1$  in the circuit of figure 12 were to open circuit, the circuit current would:

- (a) remain unchanged.
- (b) decrease.
- (c) increase.

**(d) become zero.**

6. If the resistor  $R_3$  in the circuit of figure 12 were to short circuit, the circuit current would:

- (a) decrease.
- (b) become zero.
- (c) increase.
- (d) remain unchanged.

7. If the resistor  $R_2$  in the circuit of figure 12 were to open circuit, the circuit power dissipation would:

- (a) become zero.
- (b) remain unchanged.
- (c) decrease.**
- (d) increase.

8. If the resistor  $R_1$  in the circuit of figure 12 were to short circuit, the circuit power dissipation would:

- (a) become zero.
  - (b) remain unchanged.
  - (c) decrease.**
  - (d) increase.
-

9. If an extra resistor was added in parallel with resistors  $R_2$  and  $R_3$  in the circuit of figure 12, the equivalent circuit resistance would:

- (a) increase.
- (b) decrease to zero.
- (c) decrease to a lower value.
- (d) increase to a much higher value.

10. If the resistance of the resistor  $R_1$  in the circuit of figure 12 was to be increased, the equivalent resistance of the circuit would:

- (a) increase.
- (b) decrease to zero.
- (c) decrease to a lower value.
- (d) increase to an infinite value

**Section B:**

Blank spaces in the following statements represent omissions. Write the appropriate information. **Questions 11 to 27 relate to figure 13.**

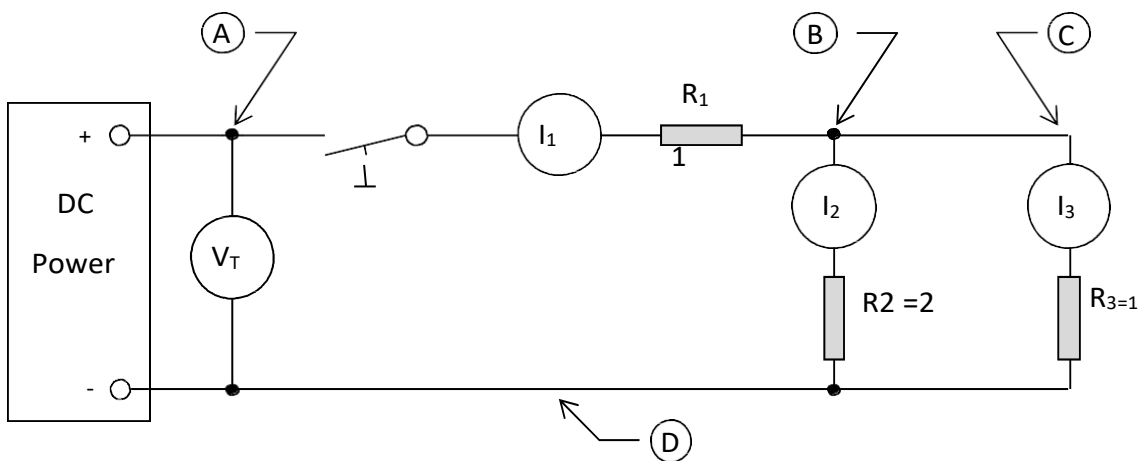

figure 13.

11. **Using the negative terminal of the power supply as a reference**, compare as either 'greater than', 'less than' or 'equal to' the voltages at the following points.

- (a) the voltage at point A would be \_\_\_\_\_ the voltage at point C  
greater than
- (b) the voltage at point D would be \_\_\_\_\_ the voltage at point B  
greater than
- (c) the voltage at point D would be \_\_\_\_\_ the voltage at point A  
equal to
- (d) the voltage at point B would be \_\_\_\_\_ the voltage at point C.



greater than

---

12. Compare as either '**greater than**', '**less than**' or '**equal to**' the currents at the following points.

(a) the current through ammeter  $I_1$  would be \_\_\_\_\_ the current through ammeter  $I_2$ .

**greater than**

(b) the current through ammeter  $I_3$  would be \_\_\_\_\_ the current through ammeter  $I_2$ .

**greater than**

(c) the current through ammeter  $I_3$  would be \_\_\_\_\_ the current through ammeter  $I_1$ .

**Less than**

(d) the current through ammeter  $I_1$  would be \_\_\_\_\_ the current at point D.

**equal to**

(e) the current at point D would be \_\_\_\_\_ the current through ammeter  $I_3$ .

**Greater than**

(f) the current in ammeter  $A_2$  would be \_\_\_\_\_ the current at point D.

**less than**

(g) The power dissipated by resistor  $R_3$  would be \_\_\_\_\_ than the power dissipated by  $R_2$ .

**Greater than**

13. If the value of the resistor  $R_2$  was increased, the equivalent circuit resistance would \_\_\_\_\_.

**decrease**

14. With the switch in the open position, the voltage across the switch would equal \_\_\_\_\_.

Supply voltage

15. The power dissipated by resistor  $R_2$  would be \_\_\_\_\_ than the power dissipated by resistor  $R_1$ . **Less than**

16. If resistor  $R_1$  became open circuit, the equivalent resistance of the circuit would be \_\_\_\_\_.

infinity

17. If resistor  $R_3$  became short circuit, the circuit current would \_\_\_\_\_ and the power dissipation would \_\_\_\_\_.

Increase, increase

SEE TEACHER CALCULATION

### SECTION C

The following problems are to be solved with the aid of a calculator. Answers are to be correct to two (2) decimal places. All equations and working are to be shown.

18. Determine the equivalent resistance for the circuit shown in figure 13. (20.29 $\Omega$ )

19. For the circuit of figure 14, determine the -

- (a) equivalent circuit resistance (209.19 $\Omega$ )
- (b) circuit current (0.478A)
- (c) voltage drop across resistor  $R_1$  (57.36V)
- (d) voltage drop across  $R_2$  and  $R_3$  (42.63V)
- (e) currents in resistors  $R_2$  and  $R_3$  (0.284A, 0.193A)
- (f) total power dissipated (47.8W)

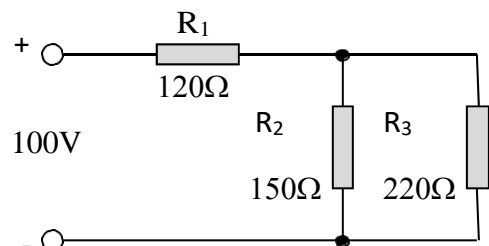

figure 14

20. For the circuit of figure 15, determine the -

- (a) equivalent resistance (8.94 $\Omega$ )
- (b) current in each branch (19.17A, 6.57A)
- (c) supply current (25.72A)

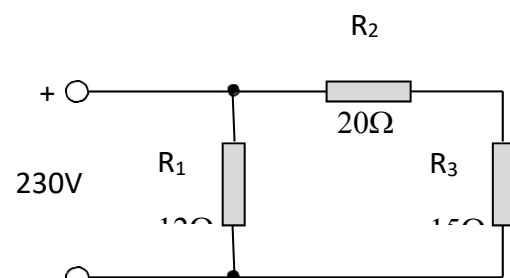

figure 15.

(d) power dissipated by each component (4408W, 863.3W, 647.47W)

(e) total power dissipation (5915.6W)

21. A circuit is made up of two resistors in parallel and has an equivalent resistance of  $15.23\Omega$ . If  $R_1$  has a resistance of  $25\Omega$  determine the resistance of  $R_2$ . ( $39\Omega$ )

# TUTORIAL – RESISTANCE 2 AND FACTORS AFFECTING RESISTANCE

**NAME:** \_\_\_\_\_

Please note the following requirements in relation to tutorial work -

- All tutorial work is to be completed on ruled A4 pad paper, with multiple pages stapled together. Write on one side only of the answer sheets.
- All work is to be completed in ink.
- In the case of multiple choice type questions, the question number and answer letter are to be written on the answer sheet.
- All relevant equations and working are to be shown in the case of calculation type questions.

## SECTION A

In the following statements one of the suggested answers is best. Place the identifying letter on your answer sheet.

1. If all other factors remain constant, the conductor having the least resistance would be:
  - (a)  $1\text{mm}^2$
  - (b)  $2.5\text{mm}^2$
  - (c)  $4\text{mm}^2$
  - (d)  $6\text{mm}^2$
  
2. If all other factors remain constant while the length of a conductor is halved, the resistance of the conductor is:
  - (a) doubled.
  - (b) squared
  - (c) halved
  - (d) quartered
  
3. The resistivity of a material:
  - (a) varies directly with length
  - (b) varies inversely with cross-sectional area
  - (c) varies directly with cross-sectional area.
  - (d) does not vary.
  
4. The unit of resistivity is the:
  - (a) ohm.
  - (b) volt-ampere.
  - (c) ampere-metre.

(d) ohm-metre.

5. If all other factors remain constant while the cross-sectional area of the conductor is halved, the resistance of the conductor will be:

(a) doubled.

(b) squared.

(c) halved.

(d) quartered.

6. The element of an electric radiator is most likely to be wound with:

(a) copper.

(b) aluminium.

(c) nichrome.

(d) manganin.

7. Doubling the length of a  $1.5\text{mm}^2$  copper conductor will cause the resistance of the conductor to:

(a) halve.

(b) double.

(c) remain unchanged.

(d) quadruple.

8. The resistance of a conductor is said to be:

(a) proportional to its length.

(b) inversely proportional to its length.

(c) proportional to its cross-sectional area.

(d) inversely proportional to its resistivity.

9. If all other factors remain constant while the length of a conductor is halved, the resistance of the conductor is:

(a) doubled.

(b) squared

(c) halved

(d) quartered

10. If all other factors remain constant while the cross-sectional area of the conductor is halved, the resistance of the conductor will be:

(a) doubled.

(b) squared.

(c) halved.

(d) quartered.

11. A material with a negative temperature coefficient of resistance would be:

- (a) steel
- (b) copper
- (c) carbon
- (d) manganin

12. As the temperature of an insulating material increases, its resistance:

- (a) increases
- (b) decreases
- (c) remains unchanged
- (d) reaches a maximum

13. If the resistance of a conductor increases with an increase in temperature, the conductor is said to have:

- (a) a positive temperature coefficient of resistance
- (b) a negative temperature coefficient of resistance
- (c) a zero temperature coefficient of resistance
- (d) no temperature coefficient of resistance

14. When the temperature of a metal conductor is increased, its resistance:

- (a) remains constant
- (b) increases
- (c) decreases
- (d) increases initially, then decreases.

15. Which of the following materials have a negative temperature coefficient of resistance:

- (a) electrolytes and gases.
- (b) metals and electrolytes.
- (c) gases and metals.
- (d) metals, gases and electrolytes.

**Section B:**

Blank spaces in the following statements represent omissions. Write the appropriate information.

16. The three physical factors that affect the resistance of a conductor are the ..... from which the conductor is made, its .....and its .....

Material, Cross sectional area, length

17. In circuits of long cable runs, larger conductors are used to .....cable voltage drop.

reduce

18. The resistance of a circuit is measured in..... , whereas the resistivity of a conductor is measured in .....

ohm , ohm-m

19. Carbon has a .....temperature coefficient of resistance.

negative

20. The amount of change in each ohm of the initial resistance of a material per degree of temperature change is termed the.....of resistance.

Temperature coefficient

21. A temperature rise in a copper conductor also causes .....in its resistance.

Increase

22. If tungsten is heated, its resistance .....

Increased

23. The resistance of all pure metals .....with an increase in temperature.

Increase

24. The temperature coefficient of a material is measured in \_\_\_\_\_.

Ohm/degree C

25. The abbreviation NTC stands for \_\_\_\_\_.

Negative Temperature Coefficient

26. The abbreviation PTC stands for \_\_\_\_\_.

Positive Temperature Coefficient





1<sup>st</sup> Digit      2<sup>nd</sup> Digit      Multiplier      Tolerance

<b>Black</b>	<b>0</b>	<b>0</b>	<b>x 1</b>	
<b>Brown</b>	<b>1</b>	<b>1</b>	<b>x10</b>	<b>±1%</b>
<b>Red</b>	<b>2</b>	<b>2</b>	<b>x10<sup>2</sup></b>	<b>±2%</b>
<b>Orange</b>	<b>3</b>	<b>3</b>	<b>x10<sup>3</sup></b>	<b>±3%</b>
<b>Yellow</b>	<b>4</b>	<b>4</b>	<b>x10<sup>4</sup></b>	<b>±4%</b>
<b>Green</b>	<b>5</b>	<b>5</b>	<b>x10<sup>5</sup></b>	<b>±0.5%</b>
<b>Blue</b>	<b>6</b>	<b>6</b>	<b>x10<sup>6</sup></b>	<b>±0.25%</b>
<b>Violet</b>	<b>7</b>	<b>7</b>	<b>x10<sup>7</sup></b>	<b>±0.1%</b>
<b>Grey</b>	<b>8</b>	<b>8</b>	<b>x10<sup>8</sup></b>	<b>±0.05%</b>
<b>White</b>	<b>9</b>	<b>9</b>	<b>x10<sup>9</sup></b>	
<b>Gold</b>			<b>x10<sup>-1</sup></b>	<b>±5%</b>
<b>Silver</b>			<b>x10<sup>-2</sup></b>	<b>±10%</b>

### SECTION C:

The following problems are to be solved with the aid of a calculator. Answers are to be correct to two (2) decimal places. All equations and working are to be shown.

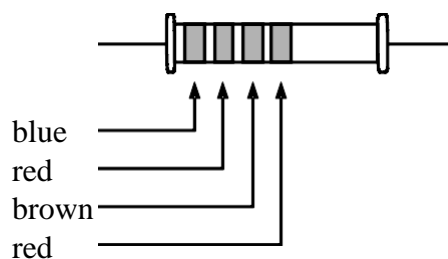

figure 11.

27. Using the resistor colour code, determine the resistance and tolerance of the resistor shown in figure 11. ( $620\ \Omega$ ,  $\pm 2\%$ ).
28. Determine the resistance of a 200 metre length of  $0.65\text{mm}^2$  aluminium conductor. The resistivity of aluminium is  $2.6 \times 10^{-8}\ \Omega\text{m}$ . ( $8\ \Omega$ )
29. Determine the cross-sectional area of a 100m length of conductor having a resistance of  $80\text{m}\Omega$ . The resistivity of the conductor is  $1.72 \times 10^{-8}\ \Omega\text{m}$ . ( $21.5\text{mm}^2$ )
30. Determine the resistance of a 30m run of  $16\text{mm}^2$  copper conductor. The resistivity of copper is  $1.72 \times 10^{-8}\ \Omega\text{m}$ . ( $0.0323\ \Omega$ )
31. Determine the resistance of a 30m run of  $2.5\text{mm}^2$  copper conductor. The resistivity of copper is  $1.72 \times 10^{-8}\ \Omega\text{m}$ . ( $0.206\ \Omega$ )
32. What length of  $2.5\text{mm}^2$  copper conductor is required to make a resistance of  $1.2\ \Omega$ . Take the resistivity of copper to be  $1.72 \times 10^{-8}\ \Omega\text{m}$ . ( $174.4\text{m}$ )
33. The circuit of a 240V, 4.8kW hot water service is shown in figure 11. The water heater is located 23m from the switchboard. The circuit was wired using  $4\text{mm}^2$  copper, twin and earth. Determine the:
- (a) resistance of the active conductor, given the resistivity of copper is  $1.72 \times 10^{-8}\ \Omega\text{m}$  ( $0.0989\ \Omega$ )
- (b) voltage drop across the active conductor, given the circuit current is 20A. ( $1.978\text{V}$ )

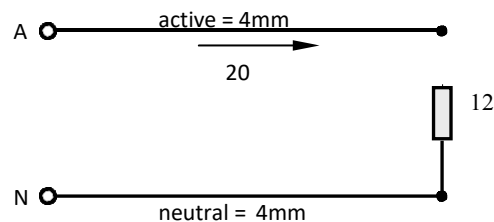

figure 11

---

# TUTORIAL – METERS

**NAME:-**

---

Please note the following requirements in relation to tutorial work -

- All tutorial work is to be completed on ruled A4 pad paper, with multiple pages stapled together. Write on one side only of the answer sheets.
- All work is to be completed in ink.
- In the case of multiple choice type questions, the question number and answer letter are to be written on the answer sheet.
- All relevant equations and working are to be shown in the case of calculation type questions.
- All diagrams are to be drawn using appropriate drawing instruments. Drawings are not to be freehand.

## Section A

In the following statements one of the suggested answers is best. Place the identifying letter on your answer sheet.

2. An increase in the size of a cable supplying a fixed load will cause the voltage drop on that cable to:

(a) decrease

- (b) increase
  - (c) stay the same
  - (d) continually change.
3. The best material for an ammeter shunt would be:
- (a) copper
  - (b) aluminium
  - (c) manganin
  - (d) carbon
4. The voltmeter sensitivity or the resistance of a voltmeter is given in terms of:
- (a) volts per ohm
  - (b) ohms per volt
  - (c) volts per ampere
  - (d) ampere per volt.
5. The basic moving coil meter movement can be used to measure larger currents if used in conjunction with a:
- (a) shunt resistor
  - (b) multiplier resistor
  - (c) series resistor
  - (d) loading resistor.
6. The basic moving coil meter movement can be used to measure higher voltages if used in conjunction with a:
- (a) shunt resistor
  - (b) multiplier resistor
  - (c) parallel resistor
  - (d) loading resistor.
7. A voltmeter has an accuracy of 1% at a full range scale of 300 V. If the meter is reading 300 V the actual voltage value could be between:
- (a) 299-301V
  - (b) 200 - 400 V
  - (c) 291 V
  - (d) 297 - 303V
8. An Ammeter has an accuracy of  $\mp 2\%$  at a full range scale of 100 A. If the meter is

reading 100 A the actual current value could be between:

- (a) 99 – 101 A
- (b) 102 A
- (c) 98 – 102 A
- (d) 96 – 98 A

9. Referring to figure 16. The purpose of  $S_1$ ,  $R_1$ ,  $R_2$  and  $R_3$  is to:

- (a) extend the range of the ammeter
- (b) short out the ammeter
- (c) be used as a multiplying resistance
- (d) load the circuit.

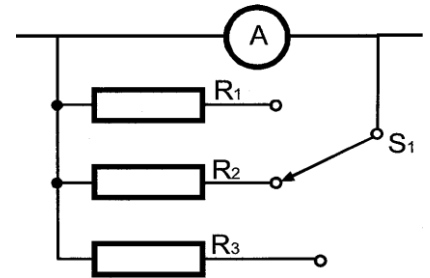

figure 16.

10. The resistance material used to extend the range of an ammeter should be made of a material which has the characteristics of a:

- (a) Voltage Dependent Resistor
- (b) Negative Temperature Coefficient resistor
- (c) Zero Temperature Coefficient resistor.
- (d) Positive Temperature Coefficient resistor.

11. If a voltmeter has low sensitivity, this means the voltmeter is:

- (a) very accurate
- (b) not accurate
- (c) more likely to load the circuit.
- (d) not sensitive to voltage changes

12. The question refers to figure 17 The current flowing in resistor  $R_{sh}$  is

- (a) 1 mA
- (b) 6 mA
- (c) 8 mA
- (d) 14 mA.

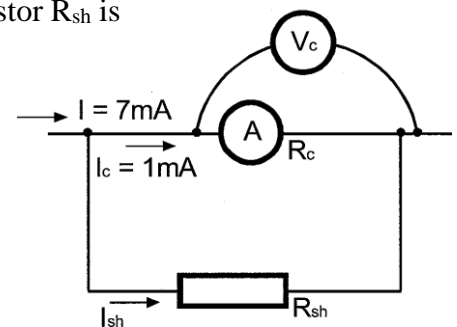

figure 17

13. Referring to figure 17. The voltage drop across resistor  $R_{sh}$  is equal to:

- (a)  $I_c \times R_{sh}$

(b)  $I_c \times R_c$

(c)  $I_{sh} \times R_c$

(d)  $I \times R_{sh}$

See Teacher Calculation

14. An AVO-7 multimeter has a sensitivity of 500 ohms/volt. Determine the resistance of the meter when used on the:

(a) 25 V range

(b) 1000 V range.

15. Referring to figure 18. Determine the:

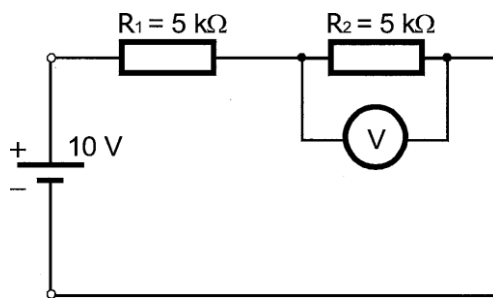

figure 18

(a) voltage across  $R_2$

(b) voltage across  $R_2$  if the voltmeter has a resistance of  $20\text{ M}\Omega$

16. Question 15 refers to figure 19, determine:

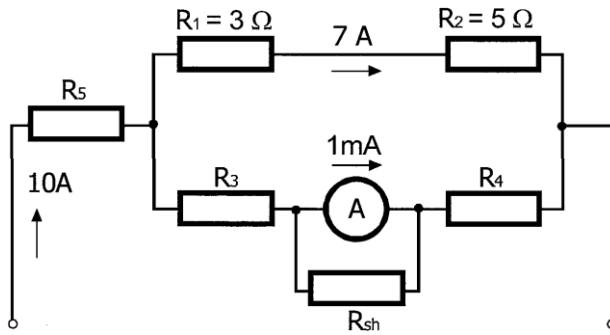

figure 19

- (a) the value of the current through  $R_{sh}$ .
- (b) the voltage drop across  $R_2$
- (c) the power rating of  $R_1$

# TUTORIAL - CAPACITORS AND CAPACITANCE

**NAME:** \_\_\_\_\_

Please note the following requirements in relation to tutorial work -

- All tutorial work is to be completed on ruled A4 pad paper, with multiple pages stapled together. Write on one side only of the answer sheets.
- All work is to be completed in ink.
- In the case of multiple choice type questions, the question number and answer letter are to be written on the answer sheet.
- All relevant equations and working are to be shown in the case of calculation type questions.
- All diagrams are to be drawn using appropriate drawing instruments. Drawings are not to be freehand.

## Section A

In the following statements one of the suggested answers is best. Place the identifying letter on your answer sheet.

1. Capacitors are classified by the material used in their:
  - (a) plates.
  - (b) dielectric.
  - (c) electrodes.
  - (d) casing.
2. The unit of capacitance is the:
  - (a) coulomb
  - (b) henry
  - (c) farad



- (d) ohm
3. A device used for storing electric charge is the:
- (a) resistor
  - (b) inductor
  - (c) capacitor
  - (d) reactor
4. Decreasing the dielectric thickness of a capacitor:
- (a) increases the capacitance
  - (b) increase the voltage it will withstand
  - (c) decreases its capacitance
  - (d) has no effect on its capacitance.
5. Which of the following cannot be used as a dielectric:
- (a) air
  - (b) paper
  - (c) carbon
  - (d) polyester
6. Decreasing the plate area of a capacitor:
- (a) increases its capacitance
  - (b) does not effect its capacitance
  - (c) decreases its capacitance
  - (d) increases its dielectric strength
7. Increasing the capacitance in an R-C circuit will cause the time constant to:
- (a) remain the same
  - (b) increase
  - (c) decrease
  - (d) reach a maximum value on charging
8. In an R-C circuit, after a period of one time constant from initial switch on, the voltage across the capacitor will be:
- (a) 100% of the supply voltage
  - (b) 63.2% of the supply voltage
  - (c) 50% of the supply voltage

- (d) 36.8% of the supply voltage
9. Increasing the resistance in an R-C circuit would cause the time constant to:
- (a) reach a maximum value on charging
  - (b) remain the same
  - (c) increase
  - (d) decrease
10. The practical unit of capacitance is the:
- (a) micro-coulomb
  - (b) milli-farad
  - (c) micro-farad
  - (d) farad.

**Section B:**

Blank spaces in the following statements represent omissions. Write the appropriate information.

11. Capacitors are classified by their \_\_\_\_\_ material.  
**Dielectric**
12. The unit of capacitance is the \_\_\_\_\_.  
**Farad**
13. A capacitor is said to be fully charged when the charging current becomes \_\_\_\_\_.  
**Zero**
14. One microfarad is equal to \_\_\_\_\_ farads.  
 **$10^{-6}$**
15. The three factors that effect the capacitance of a capacitor are the type of \_\_\_\_\_, the \_\_\_\_\_ of the plates and the \_\_\_\_\_ the plates.  
**Dielectric. Area, distance between**
16. The time constant of an R-C circuit is a measure of the time taken to \_\_\_\_\_ or \_\_\_\_\_ a capacitor. The time constant is a measure of **how long it takes for the voltage or current to rise or fall**. In an RC circuit, when a voltage is suddenly applied (step input), the capacitor gradually charges up through the resistor, reaching about 63.2% of the applied voltage after one time constant.
17. \_\_\_\_\_ type capacitors have large values of capacitance for a small physical size.

## Electrolytic

18. In an R-C circuit, the time taken to fully charge the capacitor is approximately \_\_\_\_\_ time constants.

Five

19. In a circuit containing resistance and capacitance in series the time taken for the capacitor voltage to reach 63.2% of its maximum value is known as the \_\_\_\_\_ of the circuit.

One time constant

20. The arc created by contacts opening an energised circuit may be suppressed by connecting a \_\_\_\_\_ across the contacts.

Capacitor

21. The charge stored by a capacitor depends on the capacitance of the capacitor and the \_\_\_\_\_ to which the capacitor is charged.

Voltage  $Q=CV$

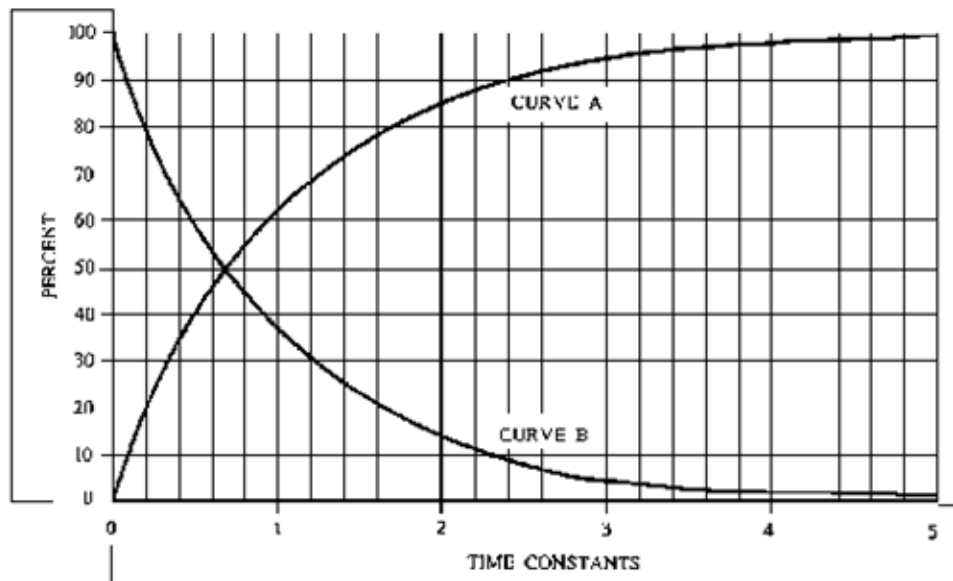

SEE TEACHER SOLUTION

### SECTION C

The following problems are to be solved with the aid of a calculator. All equations and working are to be shown.

22. Determine the charge on a  $47\mu\text{F}$  capacitor when connected to a 12V supply. ( $564\mu\text{C}$ )
23. A  $100\mu\text{F}$  capacitor is to store a charge of 0.005 coulombs. Determine the voltage that has to be applied to the capacitor. (50V)
24. Determine the capacitance of a capacitor that is required to store a charge of  $250\mu\text{C}$  when connected to a 20V supply. ( $12.5\mu\text{F}$ )

25. If a capacitor stores a charge of 15mC when connected to a 10V supply, what charge will be stored when connected to a 32V supply? (48mC)
26. An R-C circuit consists of a resistance of 120k $\Omega$  and a capacitance of 36 $\mu$ F. Determine the -
- time constant of the circuit (4.32 seconds)
  - time taken for the capacitor to fully charge. (21.6 seconds)
27. An R-C circuit has an applied voltage of 24V. What is the voltage across the capacitor after one time constant. (15.17V)
28. If the time taken to fully charge a 470 $\mu$ F capacitor is 28.2 seconds, determine the -
- time duration for one time constant (5.64 seconds)
  - value of the series resistor. (12k $\Omega$ )
29. The time constant for an R-C circuit is 33 seconds. If the series resistor has a value of 1M $\Omega$ , what is the value of the capacitor? (33 $\mu$ F)
30. A 500 $\mu$ F capacitor is connected in series with a 4k $\Omega$  resistor, and the circuit is connected to a 20V dc supply. For this circuit determine the -
- time constant (2 seconds)
  - circuit current at the instant the capacitor starts to charge (when  $V_c = 0V$ )(5mA)
  - circuit current when the capacitor is fully charged (0A)
  - capacitor voltage after 3.2 seconds using the universal time constant curve(15.6V)
  - time required for the capacitor voltage to reach 10V - use curve (1.32seconds).
  - resistor voltage after 3 time constants - use curve (0.8V)
  - circuit current after 2.5 seconds - use curve (1.5mA)
  - time taken for the circuit current to drop to 2mA - use curve (1.8seconds)

# TUTORIAL - CAPACITORS IN SERIES AND PARALLEL

**NAME:** \_\_\_\_\_

Please note the following requirements in relation to tutorial work -

- All tutorial work is to be completed on ruled A4 pad paper, with multiple pages stapled together. Write on one side only of the answer sheets.
- All work is to be completed in ink.
- In the case of multiple choice type questions, the question number and answer letter are to be written on the answer sheet.
- All relevant equations and working are to be shown in the case of calculation type questions.
- All diagrams are to be drawn using appropriate drawing instruments. Drawings are not to be freehand.

## Section A

In the following statements one of the suggested answers is best. Place the identifying letter on your answer sheet.

1. If three equal capacitors are connected in series and charged, the charge on each capacitor will be:
  - (a) one third of the total charge.
  - (b) equal to the total charge.
  - (c) three times the total charge.

(d) independent of the total charge.

2. Two,  $2\mu\text{F}$  capacitors connected in parallel will have a total capacitance of:

(a)  $4\mu\text{F}$

(b)  $2\mu\text{F}$

(c)  $1\mu\text{F}$

(d)  $0.5\mu\text{F}$

---

3. Two,  $4\mu\text{F}$  capacitors connected in series will have a total capacitance of:

(a)  $8\mu\text{F}$

(b)  $4\mu\text{F}$

(c)  $2\mu\text{F}$

(d)  $0.25\mu\text{F}$ .

4. A capacitor is a device used for:

(a) storing an electric charge.

(b) generating an electric charge.

(c) converting a.c. to d.c.

(d) creating reactance in a d.c. circuit

5. Increasing the capacitance in an R-C circuit will cause the time constant to:

(a) reach a maximum value on charging.

(b) remain the same.

(c) increase.

(d) decrease.

6. In an R-C circuit, after a period of one time constant from initial switch on, the voltage across the capacitor will be:
- (a) 36.8% of the supply voltage.
  - (b) 100% of the supply voltage.
  - (c) 63.2% of the supply voltage.
  - (d) 50% of the supply voltage.
7. Increasing the resistance in an R-C circuit would cause the time constant to:
- (a) decrease.
  - (b) reach a maximum value on charging.
  - (c) remain the same.
  - (d) increase

#### 14: Capacitor in Series and Parallel

---

8. The practical unit of capacitance is the:
- (a) farad.
  - (b) micro-coulomb.
  - (c) milli-farad.
  - (d) micro-farad

#### Section B:

Blank spaces in the following statements represent omissions. Write the appropriate information.

9. To increase the capacitance of a capacitor, you would \_\_\_\_\_ the plate area, or \_\_\_\_\_ the distance between the plates.  
**Increase / Decrease**
10. When capacitors are connected in parallel, the equivalent capacitance of the circuit will \_\_\_\_\_.  
**Be increased**
11. Capacitance is measured using a unit called the \_\_\_\_\_ (4) \_\_\_\_\_, but a more practical unit is the \_\_\_\_\_.  
**Farad , Microfarad**
12. When capacitors are connected in series, the equivalent capacitance of the circuit will \_\_\_\_\_.  
**Reduced**

13. To increase the capacitance of a circuit, capacitors are connected in \_\_\_\_\_, and to reduce the capacitance, capacitors are connected in \_\_\_\_\_.

**Parallel, Series**

14. Long cable runs with cables such as two core insulated and sheathed have capacitance. This is because the cable consists of \_\_\_\_\_ separated by an \_\_\_\_\_.

**Metallic conductor, insulation**

15. In an R-C circuit, the time taken to fully charge the capacitor is approximately \_\_\_\_\_ (11) \_\_\_\_\_ time constants.

**Five**

16. In a circuit containing resistance and capacitance in series the time taken for the capacitor voltage to reach 63.2% of its maximum value is known as the \_\_\_\_\_ of the circuit.

**One time constant**

17. The arc created by contacts opening an energised circuit may be suppressed by connecting a \_\_\_\_\_ across the contacts.

**Capacitor**

18. The charge stored by a capacitor depends on the capacitance of the capacitor and the \_\_\_\_\_ to which the capacitor is charged.

**Voltage**

**See Teacher Calculation**

The following problems are to be solved with the aid of a calculator. All equations and working are to be shown.

19. Determine the charge on a  $47\mu\text{F}$  capacitor when connected to a 12V supply. (564 $\mu\text{C}$ )

20. A capacitor has a capacitance of  $20\mu\text{F}$  and when connected to the supply stores a charge of 0.004C. Calculate the –

(a) applied voltage (200V)

(b) average charging time, if the charging current was 20mA. (0.2S)

21. What would be the equivalent capacitance of four capacitors with capacitances of 2, 4, 6 and  $12\mu\text{F}$  that are connected in –

(a) series (1 $\mu\text{F}$ )

(b) parallel (24 $\mu\text{F}$ )

22. Two capacitors having a capacitance of 8 and  $12\mu\text{F}$  respectively are connected in parallel across a 250V supply. Determine the –

(a) equivalent capacitance of the group (20 $\mu\text{F}$ )



- (b) charge stored on each capacitor (0.002C, 0.003C)  
(c) voltage across each capacitor. (250V)
23. Three capacitors having capacitances of 20, 40 and 100 $\mu$ F, are connected in parallel across a 400V supply. Determine the –
- (a) equivalent capacitance (160 $\mu$ F)  
(b) total charge stored (0.064C)  
(c) charge stored on each capacitor. (0.008C, 0.016C, 0.04C)
24. How many 5 $\mu$ F capacitors would be required to give a capacitance of 65 $\mu$ F when connected in parallel? Also determine the total charge taken when the group is supplied from a 130V supply. (13, 0.00845C)
- 
25. Three capacitors A, B and C, having capacitances of 6, 9 and 18 $\mu$ F, are connected in series across a 200V d.c. supply. Calculate the –
- (a) equivalent capacitance (3 $\mu$ F)  
(b) total charge stored (0.0006C)  
(c) charge stored on each capacitor (0.0006C)  
(d) voltage drop across each capacitor. (100V, 66.7V, 33.3V)
26. Three capacitors having capacitances of 4, 6 and 12 $\mu$ F are connected in series across a 120V supply. Calculate the –
- (a) equivalent capacitance (2 $\mu$ F)  
(b) total charge stored (0.00024C)  
(c) charge stored on each capacitor (0.00024C)
27. Three capacitors are connected in series have an equivalent capacitance of 10 $\mu$ F. If two of them have capacitances of 30 and 60 $\mu$ F, determine the capacitance of the third capacitor. (20 $\mu$ F)
28. Determine the number of 4 $\mu$ F capacitors which must be connected in series to produce an equivalent capacitance of 0.25 $\mu$ F. (16)
29. Four capacitors, each having a capacitance of 10 $\mu$ F, are available. Draw neat

diagramsshowing how they would be grouped to give –

(a) maximum capacitance.

(b) minimum capacitance.

Also calculate the maximum and minimum values of capacitance. ( $40\mu\text{F}$ ,  $2.5\mu\text{F}$ )

\*\*\*\*\*