

# Rules for Classification and Construction

## I Ship Technology

---

### 1 Seagoing Ships



### 3 Electrical Installations

**The following Rules come into force on 1 January 2016.**

**Alterations to the preceding Edition are marked by beams at the text margin.**

**DNV GL SE**

(Germanischer Lloyd SE has on 29 January 2014 changed its name to DNV GL SE. Any references in this document to Germanischer Lloyd or GL shall therefore also be a reference to DNV GL SE.)

**Head Office**

Brooktorkai 18, 20457 Hamburg, Germany

Phone: +49 40 36149-0

Fax: +49 40 36149-200

**[www.dnvgl.com](http://www.dnvgl.com)**

"General Terms and Conditions" of the respective latest edition will be applicable  
(see Rules for Classification and Construction, I - Ship Technology, Part 0 - Classification and Surveys).

Reproduction by printing or photostatic means is only permissible with the consent of  
DNV GL SE.

Published by: DNV GL SE, Hamburg

# Table of Contents

## Section 1 General Requirements and Guidance

A	General .....	1-1
B	Definitions .....	1-1
C	Documents .....	1-1
D	Further Rules and Standards to be considered .....	1-1
E	Ambient Conditions .....	1-1
F	Operating Conditions .....	1-1
G	Power Supply Systems .....	1-1
H	Voltages and Frequencies .....	1-1
I	Visual and Acoustical Signalling Devices .....	1-1
J	Materials and Insulation .....	1-1
K	Protective Measures .....	1-1

## Section 2 Installation of Electrical Equipment

A	Availability of Main Power Supply .....	2-1
B	Generators .....	2-1
C	Storage Batteries .....	2-1
D	Power Transformers .....	2-1
E	Electronics .....	2-1
F	Low-Voltage Switchboards (up to 1000 V AC resp. 1500 V DC) .....	2-1
G	Medium Voltage Equipment (> 1 kV – 17.5 kV AC) .....	2-1

## Section 3 Power Supply Installations

A	Electrical Power Demand .....	3-1
B	Main Electrical Power Supply .....	3-1
C	Emergency Electrical Power Supply .....	3-1
D	Operation of the Emergency Generator in Port .....	3-1

## Section 4 Installation Protection and Power Distribution

A	Three-Phase Main Generators .....	4-1
B	Emergency Three-Phase Generators .....	4-1
C	Direct Current Generators .....	4-1
D	Power Transformers .....	4-1
E	Storage Batteries .....	4-1
F	Power Electronics .....	4-1
G	Shore Connection .....	4-1
H	Consumer Protection Equipment .....	4-1
I	Power Distribution .....	4-1

## Section 5 Low-Voltage Switchgear Assemblies

A	General .....	5-1
---	---------------	-----

Table of Contents

---

B	Calculations.....	5-1
C	Construction.....	5-1
D	Selection of Switchgear.....	5-1
E	Choice of Electrical Protection Equipment.....	5-1
F	Conductors and Busbar Carriers.....	5-1
G	Measuring Instruments and Instrument Transformers.....	5-1
H	Testing of Switchboards and Switchgear.....	5-1

**Section 6 Power Electronics**

A	General.....	6-1
B	Construction.....	6-1
C	Rating and Design.....	6-1
D	Cooling.....	6-1
E	Control and Monitoring.....	6-1
F	Protection Equipment.....	6-1
G	Tests.....	6-1

**Section 7 Power Equipment**

A	Steering Gear.....	7-1
B	Lateral Thrust Propellers and Manoeuvring Aids.....	7-1
C	Variable Pitch Propellers for Main Propulsion Systems.....	7-1
D	Auxiliary Machinery and Systems.....	7-1
E	Deck Machinery.....	7-1
F	Electrical Heating Equipment and Heaters.....	7-1
G	Heel-Compensating Systems.....	7-1
H	Cross-flooding Arrangements.....	7-1

**Section 8 Medium-Voltage Installations**

A	Scope.....	8-1
B	General Provisions.....	8-1
C	Network Design and Protection Equipment.....	8-1
D	Electrical Equipment.....	8-1
E	Installation.....	8-1

**Section 9 Control, Monitoring and Ship's Safety Systems**

A	General Requirements.....	9-1
B	Machinery Control and Monitoring Installations.....	9-1
C	Ship Control Systems.....	9-1
D	Ship Safety Systems.....	9-1

**Section 10 Computer Systems**

A	General.....	10-1
B	Requirement Classes.....	10-1
C	System Configuration.....	10-1
D	Documents to be submitted.....	10-1

Table of Contents

---

E	Testing of Computer Systems.....	10-1
<b>Section 11 Lighting and Socket-Outlets</b>		
A	General .....	11-1
B	Lighting Installations.....	11-1
C	Socket-Outlets .....	11-1
<b>Section 12 Cable Network</b>		
A	Choice of Cables and Wires .....	12-1
B	Determination of Conductor Cross-Sections .....	12-1
C	Rating, Protection and Installation of Circuits .....	12-1
D	Installation .....	12-1
E	Requirements for Busbar Trunking Systems intended for the Electrical Supply of Distribution Panels and Single Consumers.....	12-1
<b>Section 13 Additional Rules for Electrical Main Propulsion Plants</b>		
A	General .....	13-1
B	Drives .....	13-1
C	Static Converter Installations .....	13-1
D	Control Stations.....	13-1
E	Ships' Mains .....	13-1
F	Control and Regulating .....	13-1
G	Protection of the Plant.....	13-1
H	Measuring, Indicating, Monitoring and Operating Equipment .....	13-1
I	Cables and Cable Installation .....	13-1
J	Construction Supervision, Testing and Trials .....	13-1
K	Additional Rules for Ships with redundant Propulsion Systems (RP1x%, RP2x% or RP3x%).....	13-1
<b>Section 14 Additional Rules for Passenger Vessels</b>		
A	General .....	14-1
B	Installation of Electrical Equipment.....	14-1
C	Electrical Power Supply Systems.....	14-1
D	Control-, Monitoring- and Ship's Safety Systems.....	14-1
E	Lighting.....	14-1
F	Cable Network.....	14-1
<b>Section 15 Additional Rules for Tankers</b>		
A	General .....	15-1
B	Oil Tankers, Cargo Flash Point above 60 °C.....	15-1
C	Oil Tankers, Cargo Flash Point 60 °C or below.....	15-1
D	Liquefied Gas Tankers.....	15-1
E	Chemical Tankers.....	15-1

Table of Contents

---

**Section 16 Additional Rules for Ships for the Carriage of Motor Vehicles**

A	Scope .....	16-1
B	Protection Areas .....	16-1
C	Ventilation .....	16-1
D	Fire Alarm System .....	16-1
E	Indicating and Monitoring Systems for Shell Doors .....	16-1
F	Additional Requirements for the Illumination on Ro-Ro Passenger Vessels .....	16-1
G	Installation of Electrical Equipment in Protection Areas .....	16-1
H	Permissible Electrical Equipment .....	16-1
I	Requirements for Spaces intended for Carriage of Motor Vehicles with compressed Natural Gas in their Tanks for their own Propulsion as Cargo .....	16-1
J	Requirements for Spaces intended for Carriage of Motor Vehicles with compressed Hydrogen in their Tanks for their own Propulsion as Cargo .....	16-1

**Section 17 Additional Rules for Ships for the Carriage of Dangerous Goods**

A	Scope .....	17-1
B	References to other Rules .....	17-1
C	Classes of Dangerous Goods .....	17-1
D	Hazardous Areas and permitted Electrical Equipment .....	17-1
E	Installation of Electrical Systems in Hazardous Areas .....	17-1
F	Certification if Installations not conform to the above Provisions .....	17-1
G	Fire Pumps .....	17-1
H	Alternative Electrical Power Supply for Ships intended for the Carriage of packaged irradiated Nuclear Fuel, Plutonium and high-level radioactive Wastes ....	17-1

**Section 18 Additional Rules for Bulk Carriers and Single Hold Cargo Ships other than Bulk Carriers**

A	General .....	18-1
B	Water Level Detectors .....	18-1

**Section 19 Additional Rules for Ships with Ice Class**

A	Ships with Ice Class .....	19-1
---	----------------------------	------

**Section 20 Electrical Equipment**

A	Electrical Machinery .....	20-1
B	Transformers and Reactance Coils .....	20-1
C	Capacitors .....	20-1
D	Storage Batteries, Chargers and Uninterruptible Power Supplies (UPS) .....	20-1
E	Switchgear and Protection Devices .....	20-1
F	Cables and Insulated Wires .....	20-1
G	Cable Penetrations and Fire Stops .....	20-1
H	Installation Material .....	20-1
I	Lighting Fixtures .....	20-1
J	Electrical Heating Equipment .....	20-1

Table of Contents

---

**Section 21 Tests**

A General ..... 21-1  
B Examinations of Technical Documentation..... 21-1  
C Tests in the Manufacturer's Works ..... 21-1  
D Tests on Board..... 21-1  
E Type Approvals ..... 21-1

**Section 22 Spare Parts**





## Section 1 General Requirements and Guidance

A	General .....	1-1
B	Definitions .....	1-1
C	Documents .....	1-6
D	Further Rules and Standards to be considered .....	1-6
E	Ambient Conditions .....	1-11
F	Operating Conditions .....	1-13
G	Power Supply Systems .....	1-15
H	Voltages and Frequencies .....	1-16
I	Visual and Acoustical Signalling Devices .....	1-16
J	Materials and Insulation .....	1-16
K	Protective Measures .....	1-18

### A General

#### A.1 Scope and application

**A.1.1** These Construction Rules apply to electrical and electronic equipment on seagoing ships, classified by Germanischer Lloyd (GL).

**A.1.2** Versions deviating from the Construction Rules may be approved if they have been tested for suitability and accepted as equivalent by GL.

**A.1.3** GL reserve the right to specify additional requirements to the Construction Rules where these are related to new systems or installations or where they are necessary because of new knowledge or operating experience.

Deviations from the Construction Rules may be approved where there are special reasons.

#### A.2 Design

Electrical installations shall be designed so that

- the maintaining of normal operational and habitable conditions provided on board will be ensured without recourse to the emergency source of electrical power
- the operation of the equipment required for safety will be ensured under various emergency conditions
- the safety of passengers, crew and ship from electrical hazards will be ensured.

### B Definitions

For the purpose of these Rules the following definitions apply:

#### B.1 Power supply installations

The power supply installations comprise all installations for the generating, conversion, storage and distribution of electrical energy.

## **B.2 Essential equipment**

**B.2.1** Essential for ship operation are all main propulsion plants.

**B.2.2** Essential are the auxiliary machinery and plants, which:

- are necessary for the propulsion and manoeuvrability of the ship
- are necessary for the navigation of the ship
- are required for maintaining ship's safety
- are required to maintain the safety of human life at sea

as well as

- equipment according to special Characters of Classification and Class Notations

**B.2.3** The essential equipment is subdivided into:

- primary essential equipment
- secondary essential equipment

### **B.2.3.1 Primary essential equipment**

Primary essential equipment is equipment according to [B.2.2](#) which has to be in uninterrupted operation.

It comprises e.g.:

- generator units supplying primary essential equipment
- steering gear plant
- fuel oil supply units including viscosity control equipment
- lubricating oil pumps
- cooling water/cooling media pumps
- charging air blowers
- electrical equipment for oil firing equipment
- electrical equipment for thermal oil systems
- hot and warm water generation plants
- hydraulic pumps for primary essential equipment
- controllable pitch propeller installation
- electrical main propulsion plants
- azimuth drives of the main propulsion plants
- main steam plants
- adjusting, control and safety devices/systems for primary essential equipment
- monitoring equipment for primary essential equipment

### **B.2.3.2 Secondary essential equipment**

Secondary essential equipment is equipment according to [B.2.2](#) which has not to be in uninterrupted operation for a short time.

It comprises e.g.:

- starting installations for auxiliary and main engines
- starting and control air compressor
- engine and boiler room ventilation fans
- fuel oil treatment units
- fuel oil transfer pumps
- lubrication oil treatment units
- lubrication oil transfer pumps

- heavy fuel oil heaters
- bilge and ballast pumps
- ballast water treatment systems
- heeling compensation systems
- fire pumps and fire fighting plant
- hydraulic pumps for secondary essential equipment
- electrical equipment for auxiliary steam plants
- transverse thrusters, if they are auxiliary equipment
- anchor windlass
- ventilation fans for hazardous areas
- turning gear for main engines
- generators supplying secondary essential equipment, only if this equipment is not supplied by generators as under [B.2.3.1](#)
- lighting system
- position and navigating lights, aids and signal equipment
- navigational appliances and navigational systems
- fire detection and alarm systems
- internal safety communication equipment
- bulkhead door closing equipment
- bow and stern ramps as well as shell openings
- control monitoring and safety systems for cargo containment systems
- adjusting, control and safety devices/systems for secondary essential equipment
- monitoring equipment for secondary essential equipment
- equipment necessary to meet the requirements of GL [Preliminary Guidelines for Safe Return to Port Capability of Passenger Ships \(VI-11-2\)](#)

**B.2.4** For ships with equipment according to special Characters of Classification and Notations certain type-specific plants may be classed as essential equipment.

### **B.3 Non-essential equipment**

Non-essential equipment is equipment which is not listed in [B.2](#) respectively which does not fit into the definition according to B.2.

### **B.4 Emergency consumers**

Emergency consumers are mandatory consumers which, after breakdown of the main energy supply, shall be fed by the emergency energy supply.

### **B.5 Electric network**

An electric network comprises all equipment/installations connected together at the same rated voltage.

#### **B.5.1 Isolated electric network**

This term refers to a system in which a conductor or the neutral is not connected to the ship's hull in normal operation. If it is earthed via measuring- or protective devices with a very high impedance, the system is likewise deemed to be isolated.

#### **B.5.2 Electric network with earthed neutral**

This is a system in which the neutral is connected to the ship's hull in normal operation.

## **B.6 Rated voltage of an electric network**

The rated voltage  $U_N$  (RMS value) of a system is a characteristic system parameter to which specific characteristics of the connected facilities and the limit- and test values of the system and of the facilities are referred.

## **B.7 Safety voltage**

Safety voltage is a protection provision and consists of a circuit with rated voltage not exceeding 50 V AC, operated un-earthed and isolated safely from supply circuits exceeding 50 V.

## **B.8 Low-voltage systems**

Are systems operating with rated voltages of more than 50 V up to 1000 V inclusive and with rated frequencies of 50 Hz or 60 Hz, or direct-current systems where the maximum instantaneous value of the voltage under rated operating conditions does not exceed 1500 V.

## **B.9 Medium-voltage systems**

Are systems operating with rated voltages of more than 1 kV and up to 17.5 kV inclusive and with rated frequencies of 50 Hz or 60 Hz, or direct-current systems, with the maximum instantaneous value of the voltage under rated operating conditions over 1500 V.

## **B.10 Machinery spaces**

Machinery spaces are spaces in which machines and equipment are installed and which are accessible only to authorized persons, e.g. engine rooms.

### **B.10.1 Wet operating spaces**

Wet operating spaces are spaces in which facilities may be exposed to moisture, e.g. main engine rooms.

### **B.10.2 Dry operating spaces**

Dry operating spaces are spaces in which no moisture normally occurs, e.g. engine control rooms.

### **B.10.3 Locked electrical spaces**

Locked electrical spaces are spaces which are provided with lockable doors and are intended solely for the installation of electrical equipment such as switchgear, transformers, etc. They have to be constructed as dry spaces.

### **B.10.4 Category A machinery spaces**

Category A machinery spaces are spaces which contain internal combustion engines used for the main propulsion or other purposes and having a total power output of at least 375 kW, or which contain an oil-fired boiler or an oil-treatment plant. The trunks to such spaces are included.

## **B.11 Hazardous areas**

### **B.11.1 General**

Hazardous areas are areas in which an explosive atmosphere in dangerous quantity is liable to occur owing to local and operating conditions.

Hazardous areas are divided into zones depending on the probability that an explosive atmosphere may occur.

### **B.11.2 Subdivision into zones**

Zone 0 comprises areas in which an explosive gas atmosphere is present either permanently or for long periods.

Zone 1 comprises areas in which an explosive gas atmosphere is liable to occur occasionally.

Zone 2 comprises areas in which an explosive gas atmosphere is liable to occur only rarely, and then only for a brief period (extended hazardous areas).

#### **B.12 Fire sections**

Zone between boundaries of type A for protection against propagation of fire according to the arrangements of **SOLAS** (passenger ships).

#### **B.13 Fire subdivisions**

Zone between boundaries for protection against propagation of fire according to the arrangements of **SOLAS** (passenger and cargo ships).

#### **B.14 Flame-retardation of individual cables**

Single cables and -wires are considered to be flame-retardant if they meet the test requirements of IEC publication 60332-1 regarding flame propagation.

#### **B.15 Flame-retardation of cable bunches**

Cable bunches and wire bunches are considered flame-retardant if they are flame retardant as single cables, and laid bundled, meet the requirements of IEC publication 60332-3 category A/F with regard to flame propagation.

#### **B.16 Fire-resistant cables**

Fire-resistant cables are those which under the influence of flames demonstrate function-sustaining characteristics for a certain time, e.g. 3 h, and meet the IEC publication 60331 test requirements.

#### **B.17 Cable bundles**

Arrangement of two or more cables laid parallel and directly contiguous.

#### **B.18 Systems**

Systems contain all equipment necessary for monitoring, control and safety including the in- and output devices. Systems cover defined functions including behaviour under varying operating conditions, cycles and running.

#### **B.19 Protection devices**

Protective devices detect actual values, activate alarms in the event of limit-value infringement and prevent machinery and equipment being endangered. They automatically initiate curative measures or calls for appropriate ones.

#### **B.20 Safety devices**

Safety devices detect critical limit-value infringements and prevent any immediate danger to persons, ship or machinery.

#### **B.21 Safety systems**

Combination of several safety devices and/or protection devices into one functional unit.

#### **B.22 Alarms**

An alarm gives optical and acoustical warning of abnormal operating conditions.

#### **B.23 Power electronics**

All equipment and arrangements for generation, transformation, switching and control of electrical power by the use of semi-conductor components.

## **B.24 Equipment of power electronics**

All equipment which directly affect the flow of electrical energy; consist of the functional wired semi-conductor elements together with their protection and cooling devices, the semi-conductor transformers or inductors and the switchgear in the main circuits.

# **C Documents**

## **C.1 Documents to be submitted**

### **C.1.1 Newbuildings**

**C.1.1.1** The drawings and documents listed in [Table 1.1](#) are to be submitted for examination at a sufficiently early date to ensure that they are approved and available to the Surveyor at the beginning of manufacture or installation of the electrical equipment. To facilitate a smooth and efficient approval process they shall be submitted electronically via GLOBE <sup>1</sup>. In specific cases and following prior agreement with GL they can also be submitted in paper form in triplicate.

**C.1.1.2** The drawings of switchgear and control systems are to be accompanied by parts lists indicating the manufacturers and characteristics of the electrical components, circuit diagrams together with descriptions, where these constitute a necessary aid to understanding.

The drawings and documents shall make it clear that the requirements set out in this Chapter have been complied with.

**C.1.1.3** Any non-standard symbols used are to be explained in a key.

**C.1.1.4** All documents are to be indicated with the hull number and the name of the shipyard.

**C.1.1.5** All documentation shall be submitted in English or German language.

**C.1.1.6** Forms 141 and 184 are to be submitted for each ship as mentioned in [Table 1.1](#). Copies of certificates of conformities of all installed electrical equipment for hazardous areas shall be part of the Form 184.

**C.1.1.7** GL reserve the right to demand additional documentation if that submitted is insufficient for an assessment of the installation.

### **C.1.2 Modifications and extensions**

Major modifications to the electrical installations of ships under construction or in service are subject to approval. The relevant documents are to be submitted in ample time prior to the execution of the work.

## **C.2 Documents to be kept on board**

When the ship is commissioned or following major modifications and extensions of the electrical equipment, at least the documents subject to approval, specified in [C](#) and showing the final arrangement of the electrical equipment, are to be supplied on board. The documents are to be marked with the name or the yard number of the ship, the name of the yard and the date of preparation of the documents.

# **D Further Rules and Standards to be considered**

## **D.1 GL Rules and Guidelines**

Further Rules and Guidelines of GL mentioned in this Chapter are to be observed.

---

<sup>1</sup> Detailed information about digital data exchange with GLOBE can be found on GL's website [www.mydnvgl.com](http://www.mydnvgl.com).

## D.2 National Regulations

If necessary, beside of the GL's Construction Rules national regulations are to be observed as well.

## D.3 International Regulation and Codes

**D.3.1** Where the requirements for electrical equipment and facilities are not laid down in these Rules, decision shall be made, wherever necessary, regarding the use of other regulations and standards. These include e.g. IEC publications, especially all IEC 60092 publications.

**D.3.2** The provisions of the "International Convention for the Safety of Life at Sea (**SOLAS**)" are taken into account in these Rules, insofar as these affect electrical installations.

**Table 1.1 Documents subject to approval relating to electrical equipment**

Serial No.	Documents	Basic documentation	Additional documents							
		Ships in general	Passenger ships	Ro/Ro-passenger ships	Ro/Ro-cargo ships	Ships with refrigerating installation (CRS, RCP)	Ships for the carriage of dangerous cargoes	Tankers	Oil-chemical fighting ships	Bulk carriers
<b>1. Forms</b>										
1.1	Form 141	×								
1.2	Form 184, copies of certificate of conformity			×	×		×	×	×	×
<b>2. Power-supply equipment</b>										
2.1	Electrical plant, power generating and distribution (general layout drawing)	×								
2.2	Generators, UPS units, batteries with maintenance schedule, transformers	×								
2.3	Spaces with an explosion hazard with details of installed equipment			×	×			×	×	
2.4	Short-circuit calculation, where total generators output > 500 kVA	×								
2.5	Electrical power balance (main and emergency supply)	×								
2.6	Protection coordination study with all values > 3000 kVA	×								
2.7	Main switchgear	×								
2.8	Emergency switchgear	×								
2.9	Main distribution boards	×								
2.10	Refrigerating installation: switchgear, monitoring, control and design					×				
2.11	Main cableways		×	×						

**Table 1.1 Documents subject to approval relating to electrical equipment (continued)**

Serial No.	Documents	Basic documentation	Additional documents							
		Ships in general	Passenger ships	Ro/Ro-passenger ships	Ro/Ro-cargo ships	Ships with refrigerating installation (CRS, RCP)	Ships for the carriage of dangerous cargoes	Tankers	Oil-chemical fighting ships	Bulk carriers
2.12	Main cableways for medium-voltage systems	×								
2.13	Bulkhead/deck penetrations A 60	×								
2.14	Cable layout/-list	×								
<b>3.</b>	<b>Manoeuvring equipment</b>									
3.1	Steering gear drive and control systems	×								
3.2	Rudder propeller and lateral thrust system	×								
3.3	Controllable pitch propeller system	×								
<b>4.</b>	<b>Lighting</b>									
4.1	Lighting arrangement	×								
4.2	Emergency lighting arrangement	×								
4.3	Additional emergency lighting arrangement and facilities			×						
4.4	Electric operated LLL-system		×	×						
<b>5.</b>	<b>Starting, control and monitoring equipment</b>									
5.1	Monitoring systems for machinery	×								
5.2	Safety devices/safety systems for machinery	×								
5.3	Electrical starting arrangements for auxiliary and main engines	×								
5.4	Controls and adjustments for essential equipment/drive installations	×								
5.5	Ballast water treatment system	×								



**Table 1.1 Documents subject to approval relating to electrical equipment (continued)**

Serial No.	Documents	Basic documentation	Additional documents							
		Ships in general	Passenger ships	Ro/Ro-passenger ships	Ro/Ro-cargo ships	Ships with refrigerating installation (CRS, RCP)	Ships for the carriage of dangerous cargoes	Tankers	Oil-chemical fighting ships	Bulk carriers
<b>6.</b>	<b>Ship's safety devices</b>									
6.1	General alarm systems	×								
6.2	Technical officer's alarm system	×								
6.3	Navigation and signalling lights, power supply and monitoring system	×								
6.4	Fire detection and alarm systems	×								
6.5	CO <sub>2</sub> alarm system	×								
6.6	Watertight doors operating and position monitoring system		×	×						
6.7	Fire doors operating and position monitoring system		×	×						
6.8	Control and monitoring systems for shell doors, gates and Ro/Ro decks			×	×					
6.9	Emergency shut-off facilities	×								
6.10	Tank level indicators, alarms, shut-off facilities							×	×	
6.11	Gas detector systems							×	×	
6.12	Inert gas system							×		
6.13	Fixed water-based local application fire-fighting systems (FWBLAFFS)	×								
6.14	Water ingress detection system									×
<b>7.</b>	<b>Communication systems</b>									
7.1	Public address system	×								
7.2	Important intercommunication systems	×								
<b>8.</b>	<b>Computer systems</b>									
8.1	System configuration	×								
8.2	Software version	×								

**Table 1.1 Documents subject to approval relating to electrical equipment (continued)**

Serial No. Documents	Basic documentation	Additional documents							
	Ships in general	Passenger ships	Ro/Ro-passenger ships	Ro/Ro-cargo ships	Ships with refrigerating installation (CRS, RCP)	Ships for the carriage of dangerous cargoes	Tankers	Oil-chemical fighting ships	Bulk carriers
<b>9. Electrical propulsion plants</b>									
9.1 Propulsion motors	×								
9.2 Static converters	×								
9.3 Control, adjustment, monitoring	×								
9.4 Functional description for class notation RP ..%	×								
9.5 FMEA for class notation RP ..%	×								
9.6 Trial program	×								
<b>10. Medium voltage installations</b>									
10.1 Trial program for switchgears	×								

**Table 1.2 Inclinations**

Equipment, components	Angle of Inclination [°] <sup>2</sup>			
	athwartships		longitudinally	
	static	dynamic	static	dynamic
Main engines and auxiliary machinery	15	22.5 10 s <sup>4</sup>	5	7.5
Ship's safety equipment, including, for example, emergency source of power, emergency fire pumps and other drives	22.5 <sup>3</sup>	22.5 <sup>3</sup> 10 s <sup>4</sup>	10	10
Switchgear, electric and electronic equipment <sup>1</sup> , remote controls				
<sup>1</sup> no unintended switching operations or functional changes shall occur up to an angle of inclination of 45° <sup>2</sup> inclinations may occur simultaneously athwartships and longitudinally <sup>3</sup> on ships for the carriage of liquefied gases and chemicals, the emergency power supply shall also remain operational with the ship flooded up to a maximum final athwartship inclination of 30° <sup>4</sup> rolling period				

**Table 1.3 Water temperature**

Coolant	Temperature
Seawater	+ 32 °C <sup>1</sup>
<sup>1</sup> GL may approve lower water temperatures for ships with restricted operational areas	

## **E Ambient Conditions**

### **E.1 Environmental effects**

**E.1.1** The selection, layout and arrangement of all shipboard machinery, equipment and appliances shall be such as to ensure faultless continuous operation. Therefore the manufacturer/ supplier shall be informed by the user about the expected environmental conditions. The requirements are specified in [Table 1.2](#) to 1.4.

**E.1.2** Products are classified according to their applications into the environmental categories, as stated in [Table 1.4](#).

**E.1.3** Care has to be taken of the effects on the electrical installations caused by distortions of the ship's hull.

**E.1.4** For ships intended for operation only in specified zones, GL may approve deviating ambient conditions.

### **E.1.5 Ambient temperatures for electrical equipment in areas other than machinery spaces**

**E.1.5.1** Where electrical equipment is installed within environmentally controlled spaces the ambient temperature for which the equipment is to be suitable may be reduced from 45 °C and maintained at a value not less than 35 °C provided:

- the equipment is not for use for emergency power supply (see [Section 3, C](#)) and is located outside of the machinery space(s)
- temperature control is achieved by at least two cooling units so arranged that in the event of loss of one cooling unit, for any reason, the remaining unit(s) is capable of satisfactorily maintaining the design temperature
- the equipment is able to be initially set to work safely within a 45 °C ambient temperature until such a time that the lesser ambient temperature may be achieved; the cooling equipment is to be rated for a 45 °C ambient temperature
- audible and visual alarms are provided, at a continually manned control station, to indicate any malfunction of the cooling units

**E.1.5.2** In accepting a lesser ambient temperature than 45 °C, it is to be ensured that electrical cables for their entire length are adequately rated for the maximum ambient temperature to which they are exposed along their length.

**E.1.5.3** The equipment used for cooling and maintaining the lesser ambient temperature is to be classified as a secondary essential service, in accordance with [B.2.2](#).

### **E.2 Vibrations**

#### **E.2.1 General**

**E.2.1.1** Electrical machinery and appliances are normally subjected to vibration stresses. On principle their design, construction and installation shall consider these stresses.

The faultless long-term operation of individual components shall not be impaired by vibration stresses.

**Table 1.4 Environmental conditions/ environmental categories**

Environmental Category	Environmental Conditions						Comments
	Closed Area			Open Deck Area			
	Temperature	relative Humidity	Vibrations	Temperature	relative Humidity	Vibrations	
<b>A</b>	0 °C to + 45 °C	to 100 %	0.7 g				For general applications, except category B, C, D, F, G, H.
<b>B</b>	0 °C to + 45 °C	to 100 %	4 g				For application at a higher level of vibration strain.
<b>C</b>	0 °C to + 55 °C	to 100 %	0.7 g				For application at a higher degree of heat.
<b>D</b>	0 °C to + 55 °C	to 100 %	4 g				For application at a higher degree of heat and a higher level of vibrations strain.
<b>E</b>	0 °C to + 40 °C	to 80 %	0.7 g				For use in air-conditioned areas. With GL's special consent only.
<b>F</b>				- 25 °C to + 45 °C	to 100 %	0.7 g	For application when additional influences of salt mist and temporary inundation are to be expected.
<b>G</b>				- 25 °C to + 45 °C	to 100 %	2.3 g	For use on masts, with the additional influence of salt mist.
<b>H</b>	In accordance with manufacturer's specifications						The provisions contained in the Certificates shall be observed.

**E.2.1.2** Where an electrical machine or device generates vibrations when in operation, the intensity of the vibration shall not exceed defined limits. The purpose is to protect the vibration exciter themselves, and the connected assemblies, peripheral equipment and hull components, from excessive vibration stresses liable to cause premature failures or malfunctions.

**E.2.1.3** The following provisions relate to vibrations in the 2 - 300 Hz frequency range. They are to be applied in analogous manner to higher-frequency vibrations.

**E.2.1.4** On principle investigation of vibration shall be carried out over the whole load and speed range of the vibration exciter.

## **E.2.2 Assessment**

**E.2.2.1** Assessment is based on the criteria laid down in the GL Rules for [Machinery Installations \(I-1-2\)](#), [Section 1, C.2](#).

**E.2.2.2** Assessment of the vibration loads on electrical machines and equipment is based on the areas defined in the GL Rules for [Machinery Installations \(I-1-2\)](#), [Section 1, C.2](#). It concerns vibrations which are introduced from the environment into electrical machines and equipment as well as vibrations generated from these components themselves.

**E.2.2.3** For the assignment of a vibration value to a particular area is on principle the synthesis value, not an individual harmonic component relevant.

**E.2.2.4** Electrical machines and equipment for use on board of ships shall be designed at least for a vibration load corresponding to area A (0.7g). With the agreement of GL, a lower endurance limit may be permitted in exceptional cases. In such cases, suitable countermeasures (vibration damping, etc.) shall be taken to compensate for the increased sensitivity.

**E.2.2.5** If an electrical machine or equipment generates mechanical vibrations when in service, e.g. because it is out of balance, the vibration amplitude measured on the machine or the equipment on board shall not lie outside area A. For this evaluation, reference is made only to the self-generated vibration components. Area A may only be utilized if the loading of all components, with due allowance for local excess vibration, does not impair reliable long-term operation.

**E.2.2.6** In positions exposed to particularly severe stresses, electrical machines and appliances may be loaded outside area A (0.7g). In this case the user has to inform the manufacturer about the operational requirements and the machines or the equipment shall be designed appropriately.

**E.2.2.7** Electrical appliances and equipment operating in positions where they are exposed to severe vibration loads, e.g. in the immediate vicinity of reciprocating machines, and in steering gear compartments, shall be designed for these severe vibration loads. The limit of area C (4g) shall, however, not be exceeded. Lower design parameters can be accepted subject to proof of lower vibration loading in service.

**E.2.3** Permissible alternating torque see the GL Rules for [Machinery Installations \(I-1-2\)](#), [Section 16, F](#).

## **E.2.4 Proofs**

**E.2.4.1** A vibration test in accordance with the GL Guidelines for [Test Requirements for Electrical / Electronic Equipment and Systems \(VI-7-2\)](#) is deemed to constitute proof. The test (limit A respectively C) shall conform to the operational requirements.

**E.2.4.2** Other forms of proof, e.g. calculations, may be accepted upon agreement with GL.

## **E.2.5 Measurements**

Where such measures are justified, GL reserve the right to demand that measurements be performed under operating or similar conditions. This applies both to proof of the vibration level and to the assessment of the self-generated exciter spectrum.

# **F Operating Conditions**

## **F.1 Voltage and frequency variations**

**F.1.1** All electrical equipment shall be so designed that it works faultlessly during the voltage and frequency variations occurring in the normal operation. The variations indicated in [Table 1.5](#) are to be used as a basis.

Section 1 General Requirements and Guidance

**F.1.2** Unless otherwise stated in national or international standards, all equipment shall operate satisfactorily with the variations from its rated value shown in Table 1.5 to Table 1.7 on the following conditions:

- a) For alternative current components, voltage and frequency variations shown in the Table 1.5 are to be assumed.
- b) For direct current components supplied by d.c. generators or converted by rectifiers, voltage variations shown in the Table 1.6 are to be assumed.
- c) For direct current components supplied by electrical batteries, voltage variations shown in the Table 1.7 are to be assumed.

**F.1.3** Any special system, e.g. electronic circuits, whose function cannot operate satisfactorily within the limits shown in the Table shall not be supplied directly from the system but by alternative means, e.g. through stabilized supply.

**Table 1.5 Voltage and frequency variations for a.c. distribution systems**

Quantity in operation	Variations	
	permanent	transient
Frequency	± 5 %	± 10 % (5 sec)
Voltage	+ 6 %, - 10 %	± 20 % (1.5 sec)

**Table 1.6 Voltage variations for d.c. distribution systems**

Parameters	Variations
Voltage tolerance (continuous)	± 10 %
Voltage cyclic variation deviation	5 %
Voltage ripple (a.c. r.m.s. over steady d.c. voltage)	10 %

**Table 1.7 Voltage variations for battery systems**

Systems	Variations
Components connected to the battery during charging (see Note)	+ 30 %, - 25 %
Components not connected to the battery during charging	+ 20 %, - 25 %
<b>Note</b> Different voltage variations as determined by the charging/ discharging characteristics, including ripple voltage from the charging device, may be considered.	

**F.2 Mains quality**

**F.2.1** In systems without substantial static converter load and supplied by synchronous generators, the total voltage harmonic distortion shall not exceed 5 %.

**F.2.2** In systems fed by static converters, and systems in which the static converter load predominates, for single harmonics in permanence the limit values indicated in Fig. 1.1 apply.

The total harmonic distortion shall not exceed 8 %.

**F.2.3** If in particular cases, e.g. electrical propulsion plant systems, the above-mentioned limits are exceeded, the faultless function of all electrical devices shall be secured.

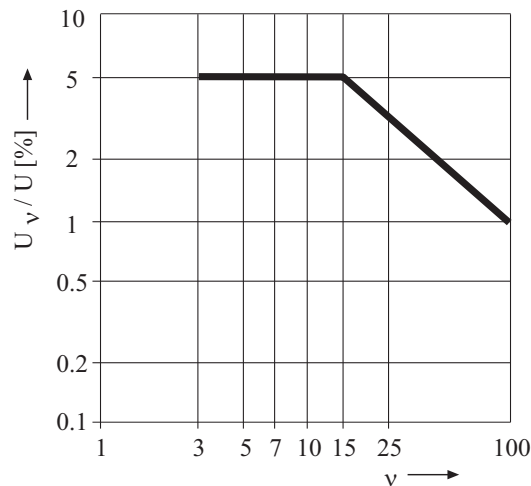

**Fig. 1.1** Limit values for the single harmonics in the supply voltage.  $U_v$  is the RMS value of the  $v$ -th order harmonic voltage

## G Power Supply Systems

### G.1 Low-voltage systems

The following systems are permitted in principle, for restrictions see G.3:

**G.1.1** For direct current and single-phase alternating current:

- 2 conductors, with one conductor earthed (1/N/PE)
- Single conductor with hull return (1/PEN)
- 2 conductors insulated from the ship's hull (2/PE)

**G.1.2** For three-phase current (alternating current):

- 4 conductors with neutral earthed, without hull return (3/N/PE)
- 3 conductors with neutral earthed, with hull return (3/PEN)
- 3 conductors insulated from the ship's hull (3/PE)

### G.2 Medium-voltage systems

See Section 8.

### G.3 Hull return conduction/system earthing

**G.3.1** The use of the ship's hull for return and/or system earthing is not permitted on tankers. For exceptions, see Section 15.

**G.3.2** Hull return is not permitted on ships of 1600 GRT and over.

**G.3.3** Excepted from G.3.1 and G.3.2 are:

- intrinsically safe circuits where this is technically required

- circuits where it is necessary for safety reasons and in which the current will not exceed 5 A during normal operation and in case of failure
- hull return of currents for systems of active corrosion protection of shells
- hull return of currents or earthing of control and measuring cables for localized installations, e.g. starting and pre-heating installations of internal combustion engines
- hull return of currents come from insulation monitoring equipment and do not exceed 30 mA
- starpoint earthing of three-phase medium voltage installations, see [Section 8, C](#)

**G.3.4** The connection of the return conductor to the hull shall be made somewhere easy to check and not in compartments with isolated bulkheads, e.g. chill/cold rooms.

#### **G.4 Systems with earthed neutral**

If the selectivity is required in view of the shut-off of earth faults and additional current-limiting devices are mounted between the generator neutral-point and the ship's hull, this shall not impair the selective shut-off of faulty circuits.

#### **G.5 Systems with non-earthed neutral**

**G.5.1** In non-earthed systems, the generator neutral points shall not be connected together.

**G.5.2** The insulation resistance of a distribution system without earthing of the system is to be monitored and displayed. For tankers, see also [Section 15, C](#).

## **H Voltages and Frequencies**

The use of standardized voltages and frequencies is recommended. The maximum permitted rated mains voltages shall be as shown in [Table 1.8](#).

## **I Visual and Acoustical Signalling Devices**

**I.1** The colours used for visual signalling devices shall conform to [Table 1.9](#).

**I.2** The use of monochrome screens is permissible, provided that clear recognition of the signals is guaranteed.

**I.3** Reference is made to the IMO-Resolution A.1021(26) "Code on Alerts and Indicators", 2009.

## **J Materials and Insulation**

### **J.1 General**

**J.1.1** The materials used for electrical machines, switchgear cables and other equipment shall be resistant to sea air containing moisture and salt, seawater and oil vapours. They shall not be hygroscopic and shall be flame-retardant and self-extinguishing.

**J.1.2** The evidence of flame-retardation shall be according to IEC publication 60092-101 or other standards, e.g. IEC publications 60695-11-10 or UL 94. Cables shall correspond to the IEC publication 60332-1.



Section 1 General Requirements and Guidance

**J.1.3** The usage of halogen-free materials is recommended. Cables for passenger vessels, see [Section 14, F](#).

**J.1.4** Units of standard industrial type may be used in areas not liable to be affected by salty sea air subject to appropriate proof of suitability.

**Table 1.8 Maximum permitted rated mains voltages**

17 500 V	for permanently installed power plants
500 V	a) for permanently installed power and control circuits b) for devices with plug-and-socket connections which are earthed either via their mounting or through a protective earth conductor c) the power supply to systems requiring special electric shock-prevention measures shall be provided via earth-leakage circuit breaker $\leq 30$ mA (not applicable to essential equipment)
250 V	a) for installations and devices, as laid down in paras a) to c) for 500 V, see above b) for permanently installed lighting systems c) for permanently installed control, monitoring and ships safety systems d) for devices supplied via plug-and-socket and requiring special electric shock-prevention measures, the power supply is to take place via a protective isolating transformer, or the device shall be double-insulated
50 V Protective extra low voltage	for portable devices for working in confined spaces where special electric shock-prevention measures are required

**Table 1.9 Colour code for signalling devices**

Colour	Meaning	Explanation
Red	Danger or alarm	Warning of danger or a situation which requires immediate action
Yellow	Caution	Change or impending change of conditions
Green	Safety (normal operating and normal working conditions)	Indication of a safe situation
Blue	Instruction/information (specific meaning assigned according to the need in the case considered, e.g. operational readiness)	Blue may be given meaning which is not covered by the three above colours: red, yellow and green
White	No specific meaning assigned (neutral)	General information, e.g. for confirmation

**J.1.5** Materials with a high tracking resistance are to be used as supports for live parts.

**J.2 Air- and creepage distances**

**J.2.1** The air- and creepage distances for essential equipment are to be dimensioned as appropriate in accordance with IEC publication 60664-1 on the basis of the following values for:

- rating operating voltage  $U_e$

- overvoltage category III
- pollution degree 3
- insulation material group IIIa

**J.2.2** For the air and creepage distances of mainbusbars in main, emergency and propulsion switchboards, see [Section 5, F.3](#).

**J.2.3** Smaller air and creepage distances may be accepted by GL provided less pollution is proved (degree of protection).

## **K Protective Measures**

### **K.1 Protection against foreign bodies and water**

**K.1.1** The protection of electrical equipment against foreign bodies and water shall be appropriate to the particular place of installation.

The minimum degrees of protection for low-voltage switchgear are listed in [Table 1.10](#).

The grade of protection of the equipment shall also be ensured during operation. Covers fitted at the place of installation are also regarded as a means of protection.

**K.1.2** Exceptions to the indications in [Table 1.10](#):

- Medium-voltage equipment, see [Section 8, Table 8.3](#)
- Electrical equipment in the reach of FWBLAFFS, see [Section 9, D.4.8](#)
- The minimum degree of protection of the terminal boxes of machines in wet operating spaces is IP 44.
- In drain wells and other installation places, where temporary flooding has to be assumed, the minimum degree of protection required for all electrical equipment is IP 56.
- Spaces subject to an explosion or fire hazard shall additionally comply with the provisions of [M.3](#), as well as with [Sections 15, 16 and 17](#).

**K.1.3** Pipe work and air ducts shall be so arranged that the electrical systems are not endangered.

**K.1.4** If the installation of pipes and ducts close to the electrical systems are unavoidable, the pipes shall not have any flanged or screwed connections in this area.

**K.1.5** Are flanged or screwed connections installed, if e.g. heat exchanger as integrated components of the electrical equipment are used, the flanged or screwed connections shall be protected with a shield or screen against leakage and condensed water.

**K.1.6** The water supply lines and recirculating lines shall be fitted with shut-off valves.

**K.1.7** Heat exchangers are preferably to install outside rooms containing major electrical equipment such as switchboards, transformer, etc.

**K.1.8** If possible the piping for cooler and heat exchangers shall be installed through the deck under the heat exchanger.

**K.1.9** The flow rate and leakage of coolants of machines and static converters with closed cooling systems in electric cabinet rooms shall be monitored and alarmed. The air ducts shall be provided with inspection holes for visual observation of the heat exchanger.

**K.1.10** A failure of cooling shall be alarmed.

Section 1 General Requirements and Guidance

**K.1.11** It is to ensure that leakage or condensation of water does not cause an electrical failure to the liquid cooled power equipment. Leakage and condensation of water shall be monitored. The cooling medium of direct cooled systems shall be monitored regarding their insulating capacity.

**K.1.12** Further requirements in [Section 2, F.1.3](#), [Section 6, D](#), [Section 13, H.2](#) and [Section 20, A.1.3.3](#) are to be observed.

**K.2 Protection against electric shock**

**K.2.1 Protection against direct contact (Basic protection)**

Protection against direct contact comprises all the measures taken to protect persons against the dangers arising from contact with the live parts of electrical facilities. Live parts are conductors and conductive parts of facilities which in normal operating condition are under voltage.

**K.2.1.1** Electrical facilities shall be so designed that, when they are used properly, persons cannot touch, or come dangerously close to live parts. For exceptions, see [K.2.1.2](#) and [K.2.1.3](#).

**K.2.1.2** In locked electrical service spaces, protection against direct contact is already maintained by the mode of installation. Insulated handrails are to be fitted near live parts.

**K.2.1.3** In systems using safety voltage protection against direct contact may be dispensed with.

**Table 1.10 Minimum degrees of protection against foreign bodies and water (in conformity with publication IEC 60529)**

Equipment Location	Generators, motors, transformers <sup>1</sup>	Switchgear, electronic equipment and recording devices <sup>1</sup>	Communications equipment, display and input units, signalling equipment, switches, power sockets, junction boxes and control elements <sup>1</sup>	Heating appliances heaters and cooking equipment	Lighting fittings
Locked dry electrical service rooms	IP00	IP00	IP20	IP20	IP20
Dry spaces, service rooms dry control rooms, accommodation	IP20	IP20	IP20	IP20	IP20
Wheelhouse, radio room, control stations	IP22	IP22	IP22	IP22	IP22
Wet spaces (e.g. machinery spaces, bow thruster room, passage ways), ventilation ducts (internal), pantries, provision rooms, store rooms	IP22 <sup>3</sup>	IP22 <sup>3</sup>	IP44 <sup>2</sup>	IP22 <sup>3</sup>	IP22 <sup>3</sup>

**Table 1.10 Minimum degrees of protection against foreign bodies and water (in conformity with publication IEC 60529) (continued)**

<b>Equipment</b>	<b>Generators, motors, transformers <sup>1</sup></b>	<b>Switchgear, electronic equipment and recording devices <sup>1</sup></b>	<b>Communications equipment, display and input units, signalling equipment, switches, power sockets, junction boxes and control elements <sup>1</sup></b>	<b>Heating appliances heaters and cooking equipment</b>	<b>Lighting fittings</b>
<b>Location</b>					
Machinery spaces below floor (bilge), separator and pump rooms, paint stores, refrigerated rooms, galleys, laundries, bathrooms and shower rooms	IP44	IP44	IP55 <sup>2,4</sup>	IP44 <sup>5</sup>	IP34 <sup>5</sup>
Pipe tunnels, ventilation ducts (to open deck), cargo holds	IP55	IP55	IP55 <sup>2</sup>	IP55	IP55
Open decks	IP56	IP56	IP56	IP56	IP55
<b>Notes</b>					
<sup>1</sup> For the degrees of protection for the equipment of watertight doors, see <a href="#">Section 14, D.7</a> . <ul style="list-style-type: none"> <li>• Motors and associated control and monitoring equipment : IPX7</li> <li>• Door position indicators : IPX8</li> <li>• Door-closure warning devices : IPX6</li> </ul> <sup>2</sup> For the degrees of protection for measuring chamber of smoke detectors : IP42 <sup>3</sup> For the degrees of protection in the adjacent area of direct spray of the FWBLAFFS: IP44 <sup>4</sup> For the degrees of protection for galleys and laundries : IP44 <sup>5</sup> For the degrees of protection for bathrooms and shower rooms in zone 0, 1, 2 see <a href="#">Section 11, C.2.2</a>					

### K.2.2 Protection against indirect contact (Fault protection)

Electrical facilities shall be made in such a way that persons are protected against dangerous contact voltages in the event of an insulation failure.

For this purpose, the construction of the facilities shall incorporate one of the following protective measures:

- protective earthing, see [K.2.3](#), or
- protection by extra-low voltage, or
- protection by electrical separation for supplying one consuming device only (voltage not exceeding 250 V), or
- protective insulation (double insulation), or
- in case where special precautions against electric shock will be necessary, the additional usage of residual current protective devices  $\leq 30$  mA (not for essential equipment).

### **K.2.3 Protective earthing**

Touchable conductive parts of equipment which are normally not live, but which may present a dangerous contact voltage in the event of a fault, are to be connected (earthed) to the ship's hull.

Where such earthing is not effective by fastening or mounting, protective earthing conductors are to be used.

For the earthing of cable shielding, armouring and braids, see [Section 12, D](#).

### **K.2.4 Protective earthing conductors**

The following points are to be noted with regard to the use of earthing conductors:

- An additional cable or an additional wire with a green/yellow coded core shall be provided as an earthing conductor, or the connection cable shall contain a green/yellow coded core. Cable braids and armouring shall not be used as earthing conductors.
- A conductor normally carrying current shall not be used simultaneously as an earthing conductor, nor may it be connected with the latter to the ship's hull. The green/yellow coded core shall not be used as a current-carrying conductor.
- The cross-section of the earthing conductor shall at least conform to the values indicated in [Table 1.11](#).
- Machines and devices which are insulated mounted are to be earthed by flexible cables, wires or stranded copper straps.
- The connection of the earthing conductor to the ship's hull shall be located at a point where it can easily be checked. Connections of earthing conductors shall be protected against corrosion.
- Insulated mounted structures and aluminium structures shall be connected to the ship's hull by special conductors at several points. The connections shall have a high electrical conductivity and shall be corrosion-resistant. The minimum cross-section is 50 mm<sup>2</sup> per conductor.

## **K.3 Explosion protection**

### **K.3.1 Hazardous areas**

#### **K.3.1.1 General**

Hazardous areas are areas in which an explosive atmosphere in dangerous quantity (a dangerous explosive atmosphere) is liable to occur owing to local and operating conditions.

Hazardous areas are divided into zones depending on the probability that a dangerous explosive atmosphere may occur.

#### **K.3.1.2 Subdivision into zones**

Zone 0 comprises areas in which a dangerous explosive atmosphere is present either permanently or for long periods. Zone 1 comprises areas in which a dangerous explosive atmosphere is liable to occur occasionally. Zone 2 comprises areas in which a dangerous explosive atmosphere is liable to occur only rarely, and then only for a brief period (extended hazardous areas).

**Table 1.11 Cross-sections for earthing conductors**

Cross-section of outer conductor [mm <sup>2</sup> ]	Minimum cross-section of earthing conductor		
	in insulated cables [mm <sup>2</sup> ]	separately laid [mm <sup>2</sup> ]	flexible cables and wires [mm <sup>2</sup> ]
0.5 to 4	equal to cross-section of outer conductor	equal to cross-section of outer conductor but not less than 1.5 for stranded and 4 for solid earth conductor	equal to cross-section of outer conductor
> 4 to 16	equal to cross-section of outer conductor	equal to half the cross-section of outer conductor but not less than 4	
> 16 to 35	16		equal to cross-section of outer conductor but not less than 16
>35 to < 120	equal to half the cross-section of outer conductor		
≥120	70	70	

### K.3.2 Hazardous areas, Zone 0

**K.3.2.1** These areas include for instance the insides of tanks and piping with a combustible liquids having a flash point ≤ 60 °C, or flammable gases, see also [K.3.9](#).

**K.3.2.2** For electrical installations in these areas the permitted equipment that may be fitted is:

- intrinsically safe circuits Ex ia
- equipment specially approved for use in zone 0 by a test organisation recognised by GL

**K.3.2.3** Cables for above mentioned equipment may be installed and shall be armoured or screened or run inside metal tubes.

### K.3.3 Hazardous areas, Zone 1

**K.3.3.1** These areas include areas like:

- paint rooms, stores for flammable liquids, see also [K.3.5](#)
- acetylen and oxygen bottle rooms, see also [K.3.6](#)
- battery rooms, see also [K.3.7](#) and [Section 2, C.2](#)
- areas with machinery, tanks or piping for fuels having a flash point ≤ 60 °C, or flammable gases, see also [K.3.8](#)
- ventilation ducts belonging to above mentioned areas
- insides of tanks, heaters, pipelines, etc. for liquids or fuels having a flash point > 60 °C, if these liquids are heated to a temperature higher than 10 °C below their flash point; see also the GL Rules for [Machinery Installations \(I-1-2\), Section 10, B.5](#).
- see also [K.3.9](#) to K.3.13

**K.3.3.2** The following electrical equipment or certified safe type equipment may be installed:

- equipment, permitted for zone 0, see [K.3.2.2](#)
- intrinsically safe circuits Ex i
- flameproof enclosure Ex d
- pressurized Ex p

## Section 1 General Requirements and Guidance

---

- increased safety Ex e
- special type of protection Ex s
- oil immersion Ex o
- encapsulation Ex m
- sand filled Ex q
- hermetically enclosed echo-sounders

**K.3.3.3** Cables for above mentioned equipment may be installed and shall be armoured or screened or run inside metal tubes, and cables for echo-sounders and cathodic protection systems, installed in thick-walled steel pipes with gastight joints up to above the main deck. Alternative technical solutions shall be agreed with GL.

### **K.3.4 Extended hazardous areas, Zone 2**

**K.3.4.1** These areas include:

- Areas directly adjoining Zone 1, but not gastight separated to it
- Areas inside an airlock
- Areas on open deck 1 m surrounding openings for natural ventilation or 3 m surrounding openings for forced ventilation for rooms, see [K.3.5](#), [K.3.6](#), [K.3.7](#), [K.3.8](#)
- see also [K.3.9](#) to K.3.13
- Enclosed areas with access to zone 1-areas may be considered as safe, if the access door is gastight and fitted with self-closing devices without holding back arrangements (watertight door may be considered as adequately gastight) and the area is ventilated from a safe area by an independent natural ventilation system (have overpressure ventilation with at least 6 changes of air per hour); or the adjacent area is naturally ventilated and protected by airlocks

**K.3.4.2** The following electrical equipment may be installed:

- equipment permitted for zone 0, see [K.3.2.2](#),
- equipment permitted for zone 1, see [K.3.3.2](#),
- equipment of Ex n- type protection,
- facilities which in operation do not cause any sparks and whose surfaces, accessible to the open air, do not attain any unacceptable temperatures,
- equipment with a degree of protection of IP 55 at least and whose surfaces, accessible to the open air, do not attain any unacceptable temperatures.

### **K.3.5 Electrical equipment in paint stores and in stores for flammable liquids**

**K.3.5.1** In the above-mentioned rooms (Zone 1) and in ventilation ducts supplying and exhausting these areas, electrical equipment shall be of certified safe type and comply at least with II B, T3.

Switches, protective devices and motor switchgear for electrical equipment in these areas shall be of all-poles switchable type and shall preferably be fitted in the safe area.

**K.3.5.2** On the open deck within a radius of 1 m (Zone 2) around natural ventilation openings (in- and outlets) or within a radius of 3 m around forced ventilation outlets (Zone 2) the requirements of [K.3.4](#) shall be fulfilled. Care shall be taken to avoid exceeding temperature class T3 or 200 °C.

**K.3.5.3** Enclosed areas with access to paint- and stores for flammable liquids may be counted as safe areas under the following conditions; if

- the access door to the room is gastight and fitted with self-closing devices and without holding back arrangements. A watertight door may be considered as being gastight; and
- the paint and stores for flammable liquids are ventilated from a safe area by an independent natural ventilation system; and
- warning labels are fixed to the outside of the access door, drawing attention to the combustible liquids in this room.

### **K.3.6 Electrical equipment in acetylene and oxygen bottle rooms**

Electrical equipment in acetylene and oxygen bottle room shall be of certified safe type with explosion protection of IIC T2 at least.

### **K.3.7 Electrical equipment in battery rooms**

Electrical equipment in battery rooms shall be of certified safe type with explosion protection of IIC T1 at least.

Arrangements and further requirements, see [Section 2, C](#).

### **K.3.8 Electrical equipment in fuel stores, flash point $\leq 60$ °C**

Electrical equipment in fuel stores shall be of certified safe type with explosion protection of IIA T3 at least.

### **K.3.9 Explosion protection on tankers**

Regarding hazardous areas and approved electrical equipment on tankers see:

- IEC 60092-502
- [Section 15](#)
- GL Rules for [Liquefied Gas Carriers \(I-1-6\)](#), see also IGC- Code of IMO
- GL Rules for [Chemical Tankers \(I-1-7\)](#), see also IBC- Code of IMO

### **K.3.10 Explosion protection for ships for the carriage of motor vehicles**

Regarding hazardous areas and approved electrical equipment on ships for the carriage of motor vehicles, see [Section 16](#).

### **K.3.11 Explosion protection for ships for the carriage of dangerous goods**

Regarding hazardous areas and approved electrical equipment on ships for the carriage of dangerous goods, see [Section 17](#).

### **K.3.12 Explosion protection in areas, dangerous owing to ignitable dust**

**K.3.12.1** These areas include rooms and spaces e.g.:

- cargo holds, see also [Section 17, D.4.1](#) and [K.4.2](#)

**K.3.12.2** The following electrical equipment may be installed:

- equipment of certified safe type for dust explosion protection
- equipment with a degree of protection of IP 55 at least and whose surfaces do not attain any unacceptable temperatures

In continuous service, the surface temperature of horizontal surfaces and surfaces inclined up to 60° to the horizontal shall be at least 75 K below the glow temperature of a 5 mm thick layer of the dust.

### **K.3.13 Explosion protection in pipe tunnels**

All equipment and devices in pipe tunnels containing fuel lines or adjoining fuel tanks shall be permanently installed irrespective of the flash point of the fuels. Where pipe tunnels directly adjoin tanks containing combustible liquids with a flash point below 60 °C, e.g. tankers, or where pipes inside these tunnels convey combustible liquids with a flash point below 60 °C, all the equipment and devices in pipe tunnels shall be certified explosion-protected in accordance with [K.3.3.2](#) (zone 1).

### **K.3.14 Permitted electrical equipment**

**K.3.14.1** Electrical equipment shall not be installed in hazardous areas Zones 0, 1 and 2, unless it is necessary for ships operation or safety. All electrical equipment, necessary to install in hazardous areas zone 0 and 1 shall be either manufactured according to a recognised standard such as IEC 60079 and certified by an authority recognised by GL or of a simple type belonging to an intrinsically safe circuit.



Certificates for electrical equipment installed in zone 2 may be requested by GL. Special conditions, mentioned in the certificates or in their instruction manuals have to be observed.

**K.3.14.2** Where electrical equipment is liable to suffer damage due to characteristics of the cargo, measures shall be taken to protect such equipment.

#### **K.3.15 Portable electrical equipment**

Portable electrical equipment, important for aboard operation and used in hazardous areas or stipulated for such use by regulations shall be of a certified safe type.

#### **K.3.16 Earthing/ Equipotential bonding/ Electrostatic charging**

**K.3.16.1** All electrical equipment in hazardous areas shall be earthed regardless of the operating voltage.

**K.3.16.2** To prevent electrostatic charging, all cargo tanks, processing plants, piping, etc. shall be durably bonded by electrical conductors and/or connected to the hull, unless they are electrically connected to the hull by welds or bolting. Not permanently installed tanks, piping systems and equipment with non conducted seals shall be connected by bonding straps. Such straps shall be designed and located that they are

- clearly visible,
- protected against corrosion and mechanical damages; and
- easy to install and replace.

**K.3.16.3** To prevent the accumulation of electrostatic charging the discharge resistance has to be less than 1 MΩ.

#### **K.3.17 Aerials / Electromagnetic radiation**

**K.3.17.1** Aerials and their riggings shall be placed outside hazardous areas.

**K.3.17.2** If aerials shall be placed in hazardous areas owing important reasons of ship construction or radio technology, the level of radiated power or field strength shall be limited to safe values acceptable to the appropriate authority.

#### **K.4 Electromagnetic compatibility (EMC)**

**K.4.1** Electrical and electronic equipment shall not be impaired in their function by electromagnetic energy. General measures are to extend with equal importance over:

- decoupling of the transmission path between source of interference and equipment prone to interference
- reduction of the causes of interference sources
- reduction of the susceptibility to interference

**K.4.2** The IEC publications 60533 and 60945 for the bridge and deck zone are to be observed.

**K.4.3** The requirements for electrical and electronic equipment subject to mandatory type approval regarding immunity and emissions of electromagnetic influence can be taken from the GL Guidelines for [Test Requirements for Electrical / Electronic Equipment and Systems \(VI-7-2\)](#).

**K.4.4** Electrical and electronic equipment on board ships, required neither by classification rules nor by international conventions, liable to cause electromagnetic disturbance shall be of a type which fulfils the test requirements of the GL Guidelines for [Test Requirements for Electrical / Electronic Equipment and Systems \(VI-7-2\)](#), [Section 3, B.21](#) and [B.22](#).

#### **K.5 Lightning protection**

Reference is made to IEC publication 60092-401.



## Section 2 Installation of Electrical Equipment

A	Availability of Main Power Supply.....	2-1
B	Generators .....	2-1
C	Storage Batteries .....	2-2
D	Power Transformers .....	2-7
E	Electronics .....	2-7
F	Low-Voltage Switchboards (up to 1000 V AC resp. 1500 V DC) .....	2-8
G	Medium Voltage Equipment (> 1 kV – 17.5 kV AC).....	2-9

### A Availability of Main Power Supply

#### A.1 Main generators

The main generators shall be installed in the main engine room or in a particular auxiliary machinery room, e.g. within the space bounded by the watertight main-bulkheads.

Partition bulkheads between these main bulkheads are not considered as separations provided they have access openings.

#### A.2 Main switchboards

Under normal conditions main switchboards shall be so placed relative to the main generators that, as far as practicable, the normal supply with electrical power may be affected only by a fire or other incidents arise in the same space. The installation of the switchboard in a control room in the same fire section or in a room separated by a partition bulkhead with sufficient access opening is not to be considered as separating the switchboard from the generators.

The main switchboard shall be located as close as practicable to the main generators, within the same machinery space and the same vertical and horizontal A 60 fire boundaries.

#### A.3 Distribution switchboards

Distribution switchboards supplying essential equipment and associated transformers, converters and similar equipment may be installed, if:

- the conditions as required for main generators / main switchboards are fulfilled,
- they are installed in the same fire section respectively in the same watertight compartment like the essential equipment itself.

### B Generators

#### B.1 Main generators with their own prime movers, independent of main propulsion plants

**B.1.1** Installation of main generator, see [A.1](#).

**B.1.2** Main generators may be installed in the foreship only with special approval and subject to the following conditions:

- Generators shall not be installed forward of the collision bulkhead below the bulkhead deck.
- The installation shall ensure faultless operation, even in heavy weather, particularly with regard to the supply of fresh air and the removal of exhaust air.

- The aggregates shall be capable of being started, connected, disconnected and monitored from the main switchboard.

## **B.2 Generators driven by the main propulsion plant**

**B.2.1** Where generators are to be incorporated in the propeller shafting, the generators and their foundations are to be suitably designed to ensure satisfactory operation of the propulsion plants even in heavy seas, regardless of the loading condition of the ship.

## **B.3 Emergency generators**

**B.3.1** Emergency generators and their prime movers shall be installed above the uppermost continuous deck and behind of the collision bulkhead. Exceptions require GL approval. The location in which the emergency generator is installed shall be accessible from the open deck; it shall be so located that a fire or another incident

- in a room containing the main generators and/or the main switchboard, or in
- a category A machinery space

will not impair the operating ability of the emergency source of electrical power. See also [F.2](#).

**B.3.2** As far as is practicable, the room containing the emergency source of electrical power, the associated transformers, converters, the transitional emergency source of electrical power and the emergency switchboard shall not adjoin the boundaries of category A machinery spaces or of those spaces which contain the main source of electrical power, the associated transformers, converters or the main switchboard.

## **C Storage Batteries**

The rules for storage batteries apply to batteries where applicable.

**C.1** Storage batteries shall be installed in such a way that persons cannot be endangered and equipment cannot be damaged by exhausted gases or leaked-out electrolytes.

**C.1.1** Storage batteries for essential equipment and associated power supply unit / charger and distribution switchboards are to be installed according [A.3](#). For example the automation battery in the engine room. For storage batteries supplying emergency consumers, [C.4](#) and [F.2.2](#) are to be observed.

**C.1.2** Storage batteries shall be so installed as to ensure accessibility for changing of cells, inspection, testing, topping-up and cleaning. Storage batteries shall not be installed in the accommodation area or in cargo holds. An exception may be granted for gastight cells, such as those used in emergency lamps, where charging does not result in the development of harmful gases.

**C.1.3** Storage batteries shall not be installed in positions where they are exposed to excessively high or low temperatures, water spray, moist, dust, condensation or other factors liable to impair their serviceability or shorten their service life. The minimum degree of protection required is IP 12.

**C.1.4** When installing storage batteries, attention is to be paid to the capacity of the associated chargers. The charging power is to be calculated as the product of the maximum charger current and the rated voltage of the storage battery.

Depending on the operating mode, application and duty of the storage battery to be charged, and on the mode of the charging (charger characteristic), and by agreement with GL, the calculation of the charging capacity need not be based on the maximum current. For the typical automatic IU- charging the calculation is stated under [C.3](#).

**C.1.5** Storage batteries are to be provided with overload and short-circuit protection nearby where they are installed. Exceptions are made for batteries for preheating and starting of internal combustion engines, but their cabling shall be made short-circuit proof.

Section 2 Installation of Electrical Equipment

---

**C.1.6** Applied materials shall comply with [Section 1, J](#).

**C.1.7** Storage batteries shall be prevented from sliding. The constraints shall not hinder ventilation.

**C.1.8** Storage batteries are subject to recycling.

**C.1.9** On tankers, storage batteries shall not be installed in the cargo area.

**C.2 Battery systems**

A battery system is an interconnection of storage batteries wired in series, parallel or as a combination of both connections. These systems are installed in cabinets or battery rooms.

**C.2.1** Only storage batteries of same electro-chemical characteristics, type, brand and year of construction shall be connected to a battery system. The selected configuration of a battery system shall not be changed.

**C.2.2** The maximum permitted voltage of a battery system is 1500V DC.

**C.2.3** Only authorised personnel shall have access to locked cabinets or battery rooms. Safety measures are to be taken against electric shock.

**C.2.4** Storage batteries shall withstand internal- and external short circuits. The level of expected short circuit current shall be considered for the DC network design and its switching and protection devices.

**C.2.5** Disconnecting devices shall be provided to isolate conductors of battery systems from circuits and if applicable from protected earth.

**C.2.6** Battery systems for redundant installations shall not be installed in the same cabinet or battery room. The requirements of redundancy shall be applied to the auxiliary systems and cooling systems as well.

**C.2.7** Battery systems for emergency supply shall not be installed in the same cabinet or battery room as storage batteries for other consumers.

**C.2.8** Battery systems shall be labelled. Access hatches or other openings to cabinets or battery rooms shall give instructions to personnel safety.

**C.2.9 Cooling system**

**C.2.9.1** No additional heat sources shall be installed in spaces of storage batteries. Cabinets or battery rooms shall be equipped with controlled heating systems if applicable.

**C.2.9.2** Redundant cooling or ventilation systems shall be provided including monitoring and alarm in case of abnormal operation.

**C.2.9.3** Preferably air- or liquid flow monitoring devices shall be provided. Differential pressure indicators are not recommended.

**C.2.10 Protection**

**C.2.10.1** A ground fault detection system shall be provided for the DC network.

**C.2.10.2** Management-, monitoring- and protection systems shall be provided. These systems are subject to GL type approval and shall include the following functions at least:

- control and monitoring during charging, discharging and operation
- protection against overcharging, discharging and against deep discharge

**C.2.10.3** An independent temperature monitoring system shall be provided. This monitoring shall give an alarm if temperature difference between the inner of cabinets or battery rooms and the environmental is too large.

**C.2.10.4** A documentation shall be submitted to verify safe operation of the battery system and relating to the personal protection.

### **C.2.11 Installation and maintenance**

**C.2.11.1** The manufacturer instructions regarding installation, maintenance, operation and cooling of the battery system are to be observed.

**C.2.11.2** Positive (+) and negative (-) wiring shall have equal wire length.

**C.2.11.3** It is recommended to check periodically cable connections and to use e.g. an infrared (IR) camera to detect hot spots in the battery system if any.

### **C.3 Equipment in cabinets and battery rooms**

**C.3.1** During charging, discharging or internal failures storage batteries could generate and release explosive gases.

**C.3.2** Only explosion-protected lamps, switches, fan motors and space-heating appliances shall be installed in battery rooms. The following minimum requirements shall be observed:

- Explosion group II C
- Temperature class T 1

Other electrical equipment is permitted only with the special approval of GL.

**C.3.3** Where leakage is possible, the inner walls of battery-rooms, boxes and cupboards, and all supports, troughs, containers and racks, shall be protected against the injurious effects of the electrolyte.

**C.3.4** Electrical equipment shall be installed in cabinets or battery rooms only when it is unavoidable for operational reasons.

### **C.4 Ventilation of spaces containing batteries**

#### **C.4.1 General requirements**

All battery-installations, except for gastight batteries, in rooms, cabinets and containers shall be constructed and ventilated in such a way as to prevent the accumulation of ignitable gas mixtures.

Gastight NiCd-, NiMH- or Li- batteries need not be ventilated.

#### **C.4.2 Batteries installed in switchboards with charging power up to 0.2 kW**

Lead batteries with a charging power up to 0.2 kW may be installed in switchboards without separation to switchgear and without any additional ventilation, if:

- a) the batteries are valve regulated (VRLA), provided with solid electrolyte
- b) the battery cases are not closed completely (IP 2X is suitable)
- c) the charger is regulated automatically by an IU- controller with a maximum continuous charging voltage of 2.3 V/cell and rated power of the charger is limited to 0.2 kW

#### **C.4.3 Ventilated spaces with battery charging power up to 2 kW**

Batteries may be installed in ventilated cabinets and containers arranged in ventilated spaces (except rooms mentioned in [C.1.1](#))

The unenclosed installation (IP 12) in well ventilated positions in machinery spaces is permitted.

Otherwise batteries shall be installed in ventilated battery cabinets or containers.

The charging power for automatic IU-charging shall be calculated as follows:

Section 2 Installation of Electrical Equipment

---

$$P = U \cdot I$$

$$I = 8 \cdot K/100 \quad \text{for Pb- batteries}$$

$$I = 16 \cdot K/100 \quad \text{for NiCd- batteries}$$

P : Charging power [W]

U : Rated battery voltage [V]

I : Charging current [A]

K : Battery capacity [Ah]

The gassing voltage shall not be exceeded. If several battery sets would be used, the sum of charging power has to be calculated.

The free air volume in the room shall be calculated depending on battery size as follows:

$$V = 2.5 \cdot Q; \quad Q = f \cdot 0.25 I \cdot n$$

V : Free air volume in the room [m<sup>3</sup>]

Q : Air quantity [m<sup>3</sup>/h]

n : Number of battery- cells in series connection

f : 0.03 for lead batteries with solid electrolyte

f : 0.11 for batteries with fluid electrolyte

If several battery sets would be installed in one room, the sum of air quantity shall be calculated.

Where the room volume or the ventilation is not sufficient, enclosed battery cabinets or containers with natural ventilation into suitable rooms or areas shall be used.

The air ducts for natural ventilation shall have a cross-section as follows, assuming an air speed of 0.5 m/s:

$$A = 5.6 \cdot Q$$

A : Cross-section [cm<sup>2</sup>]

The required minimum cross-sections of ventilation ducts are shown in [Table 2.1](#).

Small air ducts and dimensions of air inlet and outlet openings shall be calculated based on lower air speed.

#### C.4.4 Ventilated rooms with battery charging power more than 2 kW

Batteries exceeding charging power of 2 kW shall be installed in closed cabinets, containers or battery rooms forced ventilated to open deck area. Lead batteries up to 3 kW may be ventilated by natural means.

Battery rooms shall be arranged according to [C.3](#).

#### C.4.5 Ventilation requirements

Ventilation inlet and outlet openings shall be so arranged to ensure that fresh air flows over the surface of the storage battery.

The air inlet openings shall be arranged below and air outlet openings shall be arranged above.

If batteries are installed in several floors, the free distance between them shall be at least 50 mm.

Devices which obstruct the free passage of air, e.g. fire dampers and safety screens, shall not be mounted in the ventilation inlet and outlet ducts of battery-rooms.

Air ducts for natural ventilation shall lead to the open deck directly.

Openings shall be at least 0.9 m above the cupboard/ boxes. The inclination of air ducts shall not exceed 45° from vertical.

Battery room ventilators are to be fitted with a means of closing whenever:

Section 2 Installation of Electrical Equipment

- The battery room does not open directly onto an exposed deck, or
- The ventilation opening for the battery room is required to be fitted with a closing device according to the Load Line Convention (i.e. the height of the opening does not extend to more than 4.5 m (14.8 feet) above the deck for position 1 or to more than 2.3 m (7.5 feet) above the deck in position 2), or
- The battery room is fitted with a fixed gas fire extinguishing system.

Where a battery room ventilator is fitted with a closing device, then a warning notice stating, for example “This closing device is to be kept open and only closed in the event of fire or other emergency – EXPLOSIVE GAS”, is to be provided at the closing device to mitigate the possibility of inadvertent closing.

**C.4.6 Forced ventilation**

If natural ventilation is not sufficient or required cross-sections of ducts according to [Table 2.1](#) are too big, forced ventilation shall be provided.

The air quantity Q shall be calculated according to [C.3.3](#).

The air speed shall not exceed 4 m/s.

Where storage batteries are charged automatically, with automatic start of the fan at the beginning of the charging, arrangements shall be made for the ventilation to continue for at least 1 h after completion of charging.

Wherever possible, forced ventilation exhaust fans shall be used.

The fan motors shall be either certified safe type with a degree of protection IIC T1 and resistant to electrolyte or, preferably, located outside of the endangered area.

Fans are to be of non-sparking construction.

The ventilation systems shall be independent of the ventilation systems serving other rooms. Air ducts for forced ventilation shall be resistant to electrolyte and shall lead to the open deck.

**Table 2.1 Cross-section of ventilation ducts**

Calculation based on battery charging power (automatic IU- charging)			
Battery charging power [W]	Cross-section [cm <sup>2</sup> ]		
	Lead battery solid electrolyte VRLA	Lead battery fluid electrolyte	Nickel-Cadmium battery
> 500	40	60	80
500 > 1000	60	80	120
1000 > 1500	80	120	180
1500 > 2000	80	160	240
2000 > 3000	80	240	forced ventilation
> 3000	forced ventilation		

**C.5 Emergency power supply**

The location in which storage batteries for the emergency power supply are installed shall fulfil the same conditions as required for the installation of the emergency generator, see [B.3](#).

**C.6 Batteries for starting of internal combustion engines**

**C.6.1** Batteries for starting of internal combustion engines shall be installed near the engine.

**C.6.2** For the rating of the batteries, see the GL Rules for [Machinery Installations \(I-1-2\), Section 2, H.3](#).



## C.7 Caution labels

The doors or the covers of battery rooms, cupboards or boxes shall be fitted with caution labels prohibiting the exposure of open flames and smoking in, or close to, these spaces.

## C.8 Recording of the Type, Location and Maintenance Cycle of Batteries

**C.8.1** Where batteries are fitted for use for essential and emergency services a schedule of such batteries is to be compiled and maintained. The schedule, which is to be reviewed by GL, is to include at least the following information regarding the battery(ies):

- type and manufacturer's type designation
- voltage and ampere-hour rating
- location
- equipment and/or system(s) served
- maintenance/replacement cycle dates
- date(s) of last maintenance and/or replacement
- for replacement batteries in storage, the date of manufacture and shelf life <sup>1</sup>

**C.8.2** Procedures are to be put in place to ensure that where batteries are replaced that they are of an equivalent performance type.

**C.8.3** Where vented <sup>2</sup> type batteries replace valve-regulated sealed <sup>3</sup> types, it is to be ensured that there is adequate ventilation and that the GL requirements relevant to the location and installation of vented types batteries are complied with.

## D Power Transformers

**D.1** Transformers shall be installed at readily accessible and adequately ventilated places.

**D.2** The location of transformers for main electrical power supply shall fulfil the same conditions as those applying to the installation of the main generators, see [B.1](#), [Section 3, A](#) and [Section 4](#).

**D.3** The location in which transformers for the emergency electrical power supply are installed shall satisfy the same conditions as apply to the installation of the emergency generator, see [B.3](#).

**D.4** For medium-voltage transformers see [G](#).

## E Electronics

**E.1** Power electronic equipment and central units for information processing shall be installed in readily accessible and adequately ventilated spaces.

---

<sup>1</sup> Shelf life is the duration of storage under specified conditions at the end of which a battery retains the ability to give a specified performance.

<sup>2</sup> A vented battery is one in which the cells have a cover provided with an opening through which products of electrolysis and evaporation are allowed to escape freely from the cells to atmosphere.

<sup>3</sup> A valve-regulated battery is one in which cells are closed but have an arrangement (valve) which allows the escape of gas if the internal pressure exceeds a predetermined value.

**E.2** The heat generated in the unit shall be removed in a suitable manner. Where electronic equipment is installed in engine rooms or other spaces with enhanced danger of pollution and corrosion, air filters shall be provided if necessary.

## **F Low-Voltage Switchboards (up to 1000 V AC resp. 1500 V DC)**

### **F.1 Main switchboards**

**F.1.1** Installation of main switchboards, see [A.2](#).

**F.1.2** If installed on the floor above the bilge, the main switchboard shall be completely closed from below.

**F.1.3** Pipe work and air ducts shall be arranged so that the switchgear is not endangered in the event of leaks. If the installation of these pipes and ducts close to the switchboard is unavoidable, the pipes should not have any flanged or screwed connections in this area. See also [Section 1, K](#) and GL Rules for [Machinery Installations \(I-1-2\)](#), [Section 11, D.3](#) and [G.3](#).

**F.1.4** The heat generated in the switchgear shall be removed.

**F.1.5** The control passageway in front of the main switchboard shall be at least 0.9 m wide. An ample view shall be provided for the operation of the board.

Where free-standing panels are required to be accessible from behind for operation and maintenance, a passageway at least 0.6 m wide shall be provided. The width may be reduced to 0.5 m in the positions of reinforcements and frames.

**F.1.6** The floor in front of, and where necessary behind, main switchboards with an operating voltage of more than 50 V shall be provided with an appropriately insulating covering, or insulating gratings or mats (e.g. according IEC publication 61111) shall be in place.

**F.1.7** The operational space behind open switchboards shall be erected as a separated electrical service room. A label notifying this fact shall be fitted.

### **F.2 Emergency switchboards**

**F.2.1** The emergency switchboard shall be installed close to the emergency generator and/or the emergency battery. The requirements of [C](#) shall be observed. The place of installation shall satisfy the same conditions as apply to the installation of the emergency generator. The installation of the emergency switchboard is subject to the same conditions as those stated in [F.1.3](#), [F.1.4](#), [F.1.6](#) and [F.1.7](#) for the main switchboard.

**F.2.2** Where the emergency source of electrical power is a accumulator battery it shall not be installed in the same space as the emergency switchboard.

### **F.3 Main distribution boards**

The requirements set out in [F.1.2](#), [F.1.4](#) and [F.1.7](#) for main switchboards also apply to main distribution panels.

Installation, see [A.3](#).

### **F.4 Sub-distribution boards**

**F.4.1** Cubicles and niches housing distribution panels shall be made of incombustible material or be protected by a lining of metal or some other fireproof material.

The doors of cubicles and niches shall be provided with a name plate identifying the distribution panel inside. Adequate ventilation shall be ensured.

**F.4.2** Regarding additional requirements for passenger vessels, see [Section 14](#).

## **G Medium Voltage Equipment (> 1 kV – 17.5 kV AC)**

### **G.1 General**

**G.1.1** The degrees of protection stated in [Section 8, Table 8.3](#) are to be adhered.

**G.1.2** Equipment should preferably be installed in enclosed electrical service rooms.

**G.1.2.1** Electrical equipment which only ensures the lowest required protection against contact according to [Section 8, Table 8.3](#) shall be installed in a locked electrical operational compartment.

**G.1.2.2** If the lowest required protection against contact according to [Section 8, Table 8.3](#) is not ensured the equipment shall be installed in rooms whose access doors shall be locked in such a way that they can only be opened after isolating and earthing of the supply circuits.

**G.1.3** If during operation the protection against accidental arcing at the place of installation or in their vicinity not insured, the hazarded areas are to be blocked off by appropriate means and to be marked with warning labels. The continuous stay of personal in the hazarded areas shall be avoided. Therefore control panels, device for vocal communication, etc. may not be installed in this area.

**G.1.4** The place of installation of switchgear without valid arc test shall be interlocked that access should be given only when the equipment is isolated. Other components, for which an arc test is required, shall be considered accordingly.

### **G.2 Access doors to service rooms**

The access doors to spaces in which medium-voltage equipment is installed shall be provided with caution labels in accordance with [G.6](#).

### **G.3 Switchgear**

#### **G.3.1 Pressure release**

**G.3.1.1** If the gas pressure resulting from accidental arcs within the switchboard is to be vented via pressure-release flaps, the installation space shall be as specified by the switchgear manufacturer and shall have an adequate volume. Suitable measures shall be taken to ensure that the overpressure occurring within the space is limited to physiologically acceptable limits. The overpressure shall be taken into account for the structural design of the room. It is recommended to lead the accidental-arc gases by ducts of sufficient cross-section out of the place of operation.

Accidental arc gases shall be vented in a way, that the hazard of persons and equipment is minimised.

**G.3.1.2** If the switchboard is designed so that the gas pressure caused by accidental arcs is also, or only, released downwards, the floor shall be constructed so that it can withstand this pressure. Care shall be taken to ensure that sufficient volumes of space are available below the floor for the expansion of the accidental-arc gases. Combustible materials and low-voltage cables are not admissible in the endangered area.

#### **Note**

*Compartments, subjected to arc gases, shall be equipped with sufficient exhaust ventilation, where necessary supplied from the emergency switchboard.*

### **G.3.2 SF6 switchgear**

**G.3.2.1** SF6 switchgear shall only be installed in spaces which are adequately ventilated. An exhaust fan shall be provided. It shall be ensured that SF6 is prevented from flowing down to lower spaces.

#### **Note**

*It shall be taken into consideration that the coming out gases in case of accidental arcing have toxic and corrosive effects.*

**G.3.2.2** The SF6 cylinders shall be stored in a separate space with its own venting arrangements. Measures shall be taken to ensure that, in the event of leakage, no gas can flow unnoticed into any lower spaces.

### **G.3.3 Standing surface insulation**

**G.3.3.1** In front of switchboards a standing surface insulation shall be provided.

**G.3.3.2** The insulation shall be done by a suitable insulating matting (e.g. according IEC publication 61111).

**G.3.3.3** It shall be impossible to touch the front of the switchboard from outside of this insulating matting.

### **G.3.4 Auxiliaries for main switchboards**

Auxiliaries necessary for the operation of the main switchboard have to be installed so that their function is only affected by fire or other incidents within the same compartment.

### **G.4 Liquid cooled transformers**

**G.4.1** Liquid cooled transformers shall be provided with a collecting arrangement which permits the proper disposal of the liquid.

**G.4.2** A fire detector and a suitable fire extinguishing system shall be installed in the vicinity of the transformer.

### **G.5 Ship service transformers**

Ship service transformers with a degree of protection lower than the minimum required degree of protection according to [Section 8, Table 8.3](#) shall be installed in separate compartments.

### **G.6 Safety equipment**

At least the following safety equipment has to be provided for medium-voltage facilities:

- a voltage detector suitable for the rated voltage of the equipment
- a sufficient number of earthing cables according to IEC publication 61230, including insulated fitting tools
- an insulating matting (mat for repair / maintenance)
- a sufficient number of warning labels "Do not switch"
- safety instructions for gas insulated switchboards

### **G.7 Marking**

All parts of medium-voltage installations are to be fitted with permanent warning labels drawing attention to the voltage level and the danger.

## Section 3 Power Supply Installations

A	Electrical Power Demand.....	3-1
B	Main Electrical Power Supply .....	3-1
C	Emergency Electrical Power Supply.....	3-6
D	Operation of the Emergency Generator in Port.....	3-9

### A Electrical Power Demand

**A.1** A power balance of the electrical equipment has to be submitted to prove the sufficient ratings of units for the generating, storage and transformation of electrical energy.

**A.1.1** The power demand has to be determined for the following operating conditions:

- navigation at sea
- estuary trading and navigation close to port
- emergency power supply

**A.1.2** Extreme environmental conditions, e.g. arctic or tropical conditions, appropriate to the ship's area of operation are also to be taken into account.

**A.1.3** In compiling the power balance, all installed electrical consumers are to be tabulated together with an indication of their power inputs.

**A.2** For the various operating conditions, attention is to be given to:

**A.2.1** The full power input of all consumers continuously required for operation, except for those consumers which remain on standby and are used only when a similar consumer fails.

**A.2.2** The power input of all temporarily used consumers multiplied by a diversity factor.

The consumers mentioned in [A.2.3](#) are excluded.

The diversity factor shall be applied only once during the calculation.

**A.2.3** The full power input of consumers with a high power consumption relative to the main power supply, e.g. lateral thrusters (see also [B.1.4](#)).

**A.2.4** Short-term peak loads caused, for example, by the automatic starting of large motors. Proof is required of reserve power.

### B Main Electrical Power Supply

#### B.1 Design

**B.1.1** Every ship is to be provided with a main source of electrical power with sufficient capacity to meet the requirements of the plant mentioned in [Section 1, A.2](#). This main source of electrical power shall consist of at least two mutually independent generating sets.

**B.1.2** The capacity of the generating sets mentioned in [B.1.1](#) shall be such that, if any one generating set should fail or be shut down, the remaining generating capacity is sufficient to supply all those items of equipment which are needed, when navigating at sea, to ensure:

Section 3 Power Supply Installations

---

- normal operational conditions of propulsion and safety of the ship
- a minimum of comfortable conditions of habitability
- preservation of the cargo, as far as the equipment provided is part of the classification

Minimum comforts for living on board include at least adequate services for lighting, cooking, heating, domestic refrigeration, mechanical ventilation, sanitary and drinking water.

**B.1.3** For determination of generators capacity on ships with classified refrigeration equipment (class notation "**CRS**") or with other addenda to their character of classification (e.g. "dredger") the power demand arising from the associated special operating conditions shall also be considered.

**B.1.4** For determination of generators capacity on ships with classified refrigerated containers (class notation "**RCP**") the power demand according to the GL [Guidelines for the Carriage of Refrigerated Containers on Board Ships \(I-1-19\)](#) shall be considered.

**B.1.5** If no operational data are available for container connections, the following values are to be assumed when calculating the power demand:

- 20' Reefer container 8.6 kW
- 40' Reefer container 12.6 kW

For unrestricted operation of refrigerated containers and to consider all kind of reefer cargoes and operation conditions (e.g. fruit cargo and cooling down) the diversity factor 0.9 is defined.

For certain cargoes and operation conditions (e.g. deep-frozen cargo, mixed cargo) lower values could be necessary and accepted.

The power demand for the cargo holds ventilation is to be considered.

**B.1.6** Notwithstanding the provisions of [B.1.2](#), all main generators may be taken into account when considering the operation of equipment to assist in manoeuvring the vessel (e.g. lateral thrusters) and when cooling down refrigerated cargo (e.g. on Refrigerated Cargo Ships and Liquefied Gas Tankers).

**B.1.7** For ships with restricted zones of operation or intended for a special purpose, exemptions may be approved on an individual case basis.

**B.1.8** The arrangements of the ship's main source of electrical power shall be such that operation in accordance with [Section 1, A.2](#) can be maintained regardless of the speed and direction of rotation of the main propulsion machinery or shafting.

The use of generators driven by the main propulsion plant is subject to the requirements mentioned in item [B.4](#).

**B.1.9** The ship machinery installations shall be so designed, that they can be brought to operation from dead ship condition.

"Dead ship" condition means that the complete machinery plant including the main source of electrical power are out of operation and auxiliary energy as compressed air, starting current from batteries etc. are not available for the restoration of the main power supply, for the restart of the auxiliaries and for the start-up of the propulsion plant. It is however assumed that the equipment for start-up of the emergency diesel-generator is ready for use.

**B.1.10** Emergency generators or alternative means (see **SOLAS** Regulation II-1/26.4 and MSC.1/Circ.1464 section 3.1.1) may be used for the raising of the dead ship condition where the independent emergency power supply is safeguarded at any time, see also [C.1.3](#) and [B.1.4](#).

**B.1.11** It is to be ensured that in the event of failure of the main electrical power supply (blackout) this supply shall be automatically restored to operation without the aid of the emergency electrical power source.

**B.1.12** If transformers, storage batteries with their charging equipment, converters and suchlike are essential components of the main electrical power supply, the availability of the entire supply system demanded in accordance with [B.1.2](#) and [Section 2, A](#) shall remain guaranteed if any one unit breaks down.

## **B.2 Rating and control of alternating and three-phase current generators of the main electrical power supply**

### **B.2.1 Apparent power**

The apparent power of three-phase generators shall be such that no inadmissible voltage drops occur in the ship's mains due to the normal starting currents of motors. The start-up of the motor with the greatest starting current shall not give rise to a voltage drop causing other consumers to malfunction. Where a number of generators operate in parallel, this condition shall continue to be met when the largest generator is not in operation.

### **B.2.2 Waveform**

The waveform of the line-to-line no-load voltage shall be as close as possible to sinusoidal. The deviation from a sinusoidal fundamental shall at no time exceed 5 % relative to the peak value of the fundamental. The RMS values of the phase voltages shall not differ from each other by more than 0.5 % under balanced load conditions.

If the star points of generators running in parallel are earthed, the waveforms of the phase voltages should coincide. It is to ensure that the transient current due to harmonics in the starpoint connection does not exceed 20 % of the rated current of the machine with the lowest output.

### **B.2.3 Exciter equipment**

Generators and their exciters are to be rated in such a way that:

- the generator can be loaded for two minutes at 150 % of its rated current with a power factor of 0.5 lagging (inductive) and still deliver approximately its rated voltage
- the equipment is short-circuit-proof even having regard to the time lag of the generator circuit breakers necessary to the selectivity of the system

### **B.2.4 Regulating conditions**

Under balanced load conditions, three-phase generators and their exciters are required to meet the following conditions (Emergency generators, see also [C.1.6](#)):

#### **B.2.4.1 Steady regulating conditions**

With the generator running at rated speed, the voltage shall not deviate from the rated value by more than  $\pm 2.5$  % from no-load up to the rated output and at the rated power factor after the transient reactions have ceased.

#### **B.2.4.2 Transient regulating conditions**

With the generator running at rated speed and rated voltage, the voltage shall neither fall below 85 % nor exceed 120 % of the rated value when symmetrical loads of specified current and power factor are suddenly applied or removed. The voltage shall regain its rated value  $\pm 3$  % in 1.5 seconds.

If no particular requirements are specified for the load changes, the above conditions are to be satisfied when the generator, running idle and excited to its rated voltage, is suddenly loaded to 60 % of its rated current with a power factor of  $< 0.4$  (lagging), and, after steady-state operation has been achieved, the load is suddenly switched off again.

#### **B.2.4.3 Steady short-circuit current**

With a terminal short circuit on three phases, the steady short-circuit current shall not be less than three times the rated current. The generator and its exciter shall be capable of withstanding the steady short-circuit current for two seconds without damage.

### **B.2.5 Load sharing during parallel operation**

Where generators of the same output are operated in parallel, the reactive load of each machine shall not differ from its proportionate share by more than 10 % of its rated reactive power when the active load is shared equally.

In the case of generators running parallel with different ratings, the deviation from the proportionate share shall not exceed the lesser of the following values, assuming proportionately equal sharing of the active load:

- 10 % of the rated reactive power of the largest machine
- 25 % of the rated reactive power of the smallest machine

### **B.2.6 Direct current generators**

Compound generators or shunt-wound generators with automatic voltage regulators are to be preferred for sets supplying ship's mains.

Technical details and limiting values are to be agreed with GL.

## **B.3 Design and equipment of generator prime movers**

### **B.3.1 General**

The design and mechanical equipment of generator prime movers is to be undertaken in accordance with the GL Rules for [Machinery Installations \(I-1-2\)](#), [Section 2](#) and [Section 3a](#) and [3b](#).

### **B.3.2 Speed change equipment**

Every diesel engine driving a ship's main generator shall have speed change equipment which permits adequately rapid synchronization.

On ships with shaft-driven generators the range of speeds of main generator and auxiliary diesel which can be set is to be so designed that even at the minimum operating speed acceptable for shaft-driven generator operation, correct synchronization of and entering by the auxiliary units is possible in all weather conditions.

### **B.3.3 Electrical starting equipment**

Regarding electrical starting equipment see [Section 7, D.6](#).

### **B.3.4 Speed governors**

**B.3.4.1** Regarding requirements for mechanical speed governors see the GL Rules for [Machinery Installations \(I-1-2\)](#), [Section 2](#).

**B.3.4.2** Regarding additional requirements for electronic/electrical speed control see [Section 9, B](#).

### **B.3.5 Load switching**

**B.3.5.1** Regarding further requirements see the GL Rules for [Machinery Installations \(I-1-2\)](#), [Section 2, F](#).

### **B.3.5.2 Load cutting in**

If the load switching in two steps is provided, it is to be realised as follows: immediately from 'no load' to 50 %, followed by the remaining 50 % of the generator output while remaining within the permissible speed-change limits.

Load switching in more than two steps is permissible provided that:

- the design of the ship's mains makes possible the operational application of such units
- load switching in more than two steps has been given appropriate consideration at the design stage of the ship's mains and is approved through the drawing checks
- proof of unobjectionable functioning is provided in the course of the on-board tests. This is to include consideration of the loading of the ship's mains under stepped switching-in of essential equipment following breakdown and reconstruction of the ship's mains
- the safety of the ship's mains under parallel operation of the generators and failure of a generator is to be proved.



### **B.3.5.3 Load shedding**

Load shedding of 100 % of the generator rated output, while adhering to the permissible speed changes, shall be proven.

### **B.3.6 Parallel operation**

**B.3.6.1** The speed characteristics of prime movers shall be linear over the entire output range.

The governing characteristics of prime movers of units of the same output operating in parallel shall ensure that, over the range from 20 % to 100 % of the total active power, the share of each machine does not deviate from its proportionate share by more than 15 % of its rated active power.

**B.3.6.2** Where the units are differently rated, the deviation from the proportionate share within the stated load range shall not exceed the lesser of the following values:

- 15 % of the rated active power of the largest machine
- 25 % of the rated active power of the smallest machine

### **B.3.7 Cyclic irregularity**

The permissible cyclic irregularity is to be agreed between the manufacturers of the prime movers and the generators. The following points have to be ensured:

- Faultless parallel operation of three-phase generators
- Load variations shall not give rise to fluctuations in active power output exceeding 10 % of the rated output of the machine concerned.

## **B.4 Generators driven by the main propulsion plant (e.g. shaft-driven generators)**

**B.4.1** Generators driven by the main propulsion plant may be deemed to constitute part of the main electrical power supply in accordance with [B.1](#) provided they can be operated under all weather-, navigating and manoeuvring conditions, including stopped ship by supplying sufficient load. The operating conditions for frequency stated in [Section 1, F](#) shall be fulfilled. Voltage and load sharing shall be in the limits acc. to [B.2.1](#), [B.2.2](#), [B.2.4.1](#), [B.2.4.2](#) and [B.2.5](#) (only to be observed in case of parallel operation).

**B.4.1.1** It is an essential requirement that, should any generator or its prime mover fail, the conditions stated in [B.1.2](#) shall be satisfied, and it shall also be possible to start the main propulsion plant in accordance with [B.1.9](#), [B.1.10](#) and [C.1.4](#).

**B.4.1.2** The generators shall be protected in such a way that a short-circuit in the main busbars will not cause a damage in the generator system and a subsequent restoration of normal generator function will be possible.

**B.4.2** Generators which are driven by the main propulsion plant but which fail to conform to the conditions stated in [B.4.1](#) are not considered to constitute part of the main electrical power supply, although they may be used as additional generators and on occasion maintain the entire power supply function provided the following conditions are met:

- Where main propulsion plants are not driven at constant speed, regulators should be fitted enabling the generator plant to deliver an adequate output over a speed range of the main engine from at least 75 % to 100 %.
- Frequencies are to be kept within the limits stated in [Section 1, F](#). For voltage and load sharing (only in case of parallel operation) furthermore the conditions stated in [B.2.1](#), [B.2.4.1](#), [B.2.4.2](#) and [B.2.5](#) are to be fulfilled.
- On ships with remote control of the main engine from the bridge, it is necessary to ensure that, when manoeuvres preventing the continued operation of the shaftdriven generator plant are initiated, the supply to essential equipment is maintained from the shaft-driven generator plant until the load has been shifted to a stand-by generator.

**B.4.3** For the selectivity demands of the distribution system the short-circuit current shall be sufficient.

**B.4.4** In case of frequency deviations exceeding 10 %, the generator is to be disconnected within 10-30 seconds.

**B.4.5** Provision shall be made for decoupling generators not lying in the line of the propeller shaft.

## **B.5 Availability of the main electrical source**

**B.5.1** Where the main source of electrical power is necessary for propulsion and steering of the ship, the system shall be so arranged that the supply of the primary essential equipment will be maintained or immediately restored in the case of loss of any one of the generators in service.

**B.5.2** To fulfil the demands named in [B.5.1](#), at least the following measures are required:

**B.5.2.1** Automatic load shedding of the non-essential and, where necessary, secondary essential equipment to protect the generators against overload.

**B.5.2.2** Automatic start-up of a stand-by unit on failure of the power supply.

At least two units shall be provided according to [B](#). They shall be capable of reciprocal operation. The output of each unit shall be so rated as to ensure automatic start-up of the primary essential equipment. Where necessary, equipment may be switched on in staggered formation.

**B.5.2.3** Start-up and connecting of a stand-by unit from the bridge with special approval. The requirements specified in [B.5.2.2](#) are to be observed.

**B.5.2.4** The automatic starting and connecting on of a generator and the primary essential equipment after black-out shall follow as quick as possible, but within not more than 30 seconds. Where diesel engines with longer starting times are used the starting and connecting times might be exceeded with approval of GL.

**B.5.2.5** Where several generator units are required to cover the ship's power supply in permanent parallel operation, the failure of already one of the units shall cause the immediate trip of non-essential equipment and, where necessary, the secondary essential equipment, where this is the only way to ensure that the remaining units can supply the primary essential equipment.

## **C Emergency Electrical Power Supply**

### **C.1 General requirements**

**C.1.1** The emergency source of electrical power shall take over the supply of the emergency consumers in case of failure of the main source of electrical power. It shall be independent of the main source of electrical power.

**C.1.2** The capacity of the emergency source of electrical power shall be sufficient to supply all those services which are essential for safety in an emergency.

**C.1.3** Provided that suitable measures are taken for safeguarding independent emergency operation under all circumstances, the emergency generator may be used exceptionally and for short periods to supply non-emergency circuits, see also [B.1.10](#) and [D](#).

**C.1.4** For ships which need electrical power to restore propulsion, the capacity of the emergency source of power shall be sufficient to restore propulsion to the ship in conjunction with other auxiliary machinery, as appropriate, within 30 min. after blackout. It is assumed that starting energy is not available after blackout. For steam ships the 30 min. admit until start up of the first boiler, see also [B.1.7](#) and [C.1.8](#).

**C.1.5** For all equipment forming part of the emergency source of electrical power, provision shall be made for periodic functional tests, including especially the testing of automatic switching and starting devices. Such testing shall be possible without interfering with other aspects of the ship's operation.

**C.1.6** For the rating and control of the emergency generators, the same principles apply as for the main generators in accordance with B.2. Unlike in B.2.4, voltage deviations of  $\pm 3.5\%$  under steady conditions and of  $\pm 4\%$  under transient conditions after 5 s are acceptable.

**C.1.7** Regarding electric starting equipment see Section 7, D.6.

**C.1.8** Where fins of stabilizing systems are in the area of embarking stations of life boats, these systems and indicators on the navigation bridge shall be connected to the emergency source of power.

## **C.2 Emergency electrical power supply on passenger ships**

Regarding emergency electrical power supply on passenger ships see Section 14, C.

## **C.3 Emergency electrical power supply on cargo ships**

**C.3.1** All cargo ships of 500 GRT and over are to be provided with a self-contained emergency source of electrical power.

**C.3.2** With due allowance for starting currents, the emergency source of electrical power shall be capable of simultaneously supplying at least the following services for the period specified below, if their operation depends upon an electrical source:

**C.3.2.1** For 3 hours, the emergency lighting at every embarkation station for survival craft and rescue boats on deck and along the ship's sides in this area.

**C.3.2.2** For 18 hours, the emergency lighting

- a) in all service and accommodation alleyways, on stairways, at exits and in personnel lift cars and shafts
- b) in engine rooms and main generator stations, including their control positions
- c) in all control stations, bridge, engine control rooms and at each main and emergency switchboard
- d) at all stowage positions for firemen's outfits
- e) in the steering gear compartment, and the CO<sub>2</sub> room
- f) at the fire pump mentioned in C.3.2.5, at the sprinkler pump, if any, the emergency bilge pump, if any, and at the start-up position for their motors
- g) in all cargo pump-rooms of tankers

**C.3.2.3** For 18 hours

- a) the navigation lights and other lights required by the current "International Regulations for Preventing Collisions at Sea"
- b) the VHF radio installation required in SOLAS IV and, where provided, the MF radio installation, as well as the ship earth station and the MF/RF radio installation

**C.3.2.4** For 18 hours

- a) all internal signalling and communications equipment required in an emergency
- b) all ship's navigational appliances stipulated by SOLAS V/19
- c) the fire detection and fire alarm system
- d) the intermittent operation of the daylight signalling lamp, the ship's whistle, the manually operated fire alarms and all the internal signals required in an emergency, e.g. general alarm, and CO<sub>2</sub> alarm

unless these services can be independently supplied during this 18-hour period by an emergency storage battery.

**C.3.2.5** For 18 hours

- a) the required emergency fire pump
- b) the water-spraying systems for machinery spaces of Category A and cargo pump rooms
- c) the auxiliary equipment for the emergency generator set

d) at least one bilge pump for cargo spaces on open-top container ships

**C.3.2.6** The steering gear for the time specified in [Section 7, A.2](#), where an emergency supply is stipulated, and also the rudder angle indicator.

**C.3.3** In the case of ships which regularly undertake voyages of limited duration, the national authorities may accept a period shorter than the 18 hours specified in [C.3.2.2](#) – [C.3.2.5](#), but not less than 12 hours, if they are satisfied that this ensures an adequate standard of safety being attained.

**C.3.4** The emergency source of electrical power for cargo ships may be either a generator set or a storage battery.

**C.3.4.1** Where the emergency source of electrical power is a generator set, it shall be driven by a suitable prime mover with its own independent fuel supply in accordance with the GL Rules for [Machinery Installations \(I-1-2\)](#), [Section 10](#) and with an independent cooling system.

The set shall start up automatically if the main source of electrical power fails, and the supply of the listed consumers shall be automatically taken over by the emergency generator set, unless a transitional emergency power source in accordance with [C.3.4.2](#) is provided.

The emergency supply of electrical power shall come into operation as quickly as possible, and in any event not later than 45 seconds after the failure of the main source of electrical power.

**C.3.4.2** The transitional source of emergency electrical power shall be a storage battery which, in the event of failure of the main source of electrical power, automatically and immediately supplies the consumers listed below until the emergency generator set described in [C.3.4.1](#) is put into operation and connected.

Its capacity shall be sufficient to supply the consumers for a period of at least 30 minutes, during which time the battery voltage shall remain within  $\pm 12\%$  of the rated voltage, without intermediate recharging.

Where called for and dependent on an electrical power source, the following consumers are to be supplied:

- a) the lighting specified in [C.3.2.1](#), [C.3.2.2](#) and [C.3.2.3](#) a). The necessary emergency lighting of the machinery space and the accommodation and service spaces can be provided by permanently fixed, self-contained, battery-powered lamps and
- b) all the services specified in [C.3.2.4](#) a), [C.3.2.4](#) c) and [C.3.2.4](#) d), unless such services are independently supplied for the prescribed period by an emergency storage battery

**C.3.4.3** If the emergency source of electrical power is a storage battery, it shall meet the functional requirements stated in [C.3.4.2](#).

#### **C.4 Emergency consumers protecting the main propulsion plant**

In rating the emergency source of electrical power, consideration is to be given, where applicable, to other consumers required to protect the main propulsion plant in the event of a failure of the main source of electrical power. Such consumers may, for example, include the emergency lubricating oil supply and the turning gear on turbine plant. The measures to be taken are to be agreed with GL in each particular case.

#### **C.5 Emergency electrical power supply for special purpose ships in accordance with IMO-Resolution MSC.266(84)**

**C.5.1** Within the meaning of this Section, "special purpose ships" are ships of 500 GRT and over in which 12 persons apart from the crew are carried for an extended period for the performance of special tasks. They include, for example, research ships, drilling vessels, etc. Consideration is given to the number of additional personnel and to the size of the ship when deciding whether the ship is to be treated as a cargo ship or a passenger ship for the purpose of its emergency electrical power supply.

**C.5.2** "Special purpose ships" not more than 50 m in length and carrying not more than 60 persons on board are treated as cargo ships in accordance with [C.1](#) and [C.3](#)

**C.5.3** If the length of the ship is greater than 50 m, the closure system for watertight doors in bulkheads and its indicators are to be connected to the emergency electrical power supply, as on passenger ships in accordance with [Section 14](#).

**C.5.4** With regard to their emergency power supply, "special purpose ships" carrying more than 60 persons on board are to be treated in every respect as passenger ships in accordance with [Section 14](#).

## D Operation of the Emergency Generator in Port

### D.1 General

The emergency generator may be used during lay time in the harbour for the main power supply, provided the undermentioned requirements are complied with (see also [C.1.3](#)).

### D.2 Requirements

**D.2.1** The independence of the emergency power supply from other auxiliaries of the main engine plant shall be ensured during manoeuvring in port, during estuary trading and during sea service.

**D.2.2** The emergency diesel-generator shall be protected against overload by tripping of the transferline. If necessary, a tripping of non-emergency load shall be provided to ensure continued safe operation of the generator set.

**D.2.3** The emergency power supply installations shall be arranged and protected in such a way that an interruption of cables, as short circuit or an earth-fault caused by fire or by another event neither in spaces where the components of main electrical power supply with their associated accessories are installed nor in other machinery spaces of category A will not interfere with control, monitoring, auxiliary power supply and power distribution of the emergency electrical power supply.

For safe operation selector switches with switching positions port operation – emergency operation shall be provided in the emergency switchboard, see [Section 5, C.3.2](#).

**D.2.4** The location where the emergency generator set and the emergency switchboard are installed shall be covered by means of a fire detections system similar to those required for unattended main and auxiliary machinery spaces, see [Section 9, D.3.5](#).

**D.2.5** The prime mover shall be designed for continuous operation and shall be subject to planned maintenance in order to ensure its operational readiness in case of emergency.

The prime mover and the generator shall be provided with monitoring, protective and safety devices as required for auxiliary engines and main generators intended for unattended operation, e.g. stop at lub. oil pressure too low.

The prime mover shall be equipped with switch-over filters (2 or more filter chambers, e.g. Duplex-filter) for fuel oil and lubrication oil which enable cleaning during operation.

**D.2.6** The fuel oil supply tank to the emergency-/ port diesel generator set shall be provided with a low level alarm arranged at a level of fuel sufficient for a duration of operation required acc. to [C.3](#) respectively [Section 14, C.1](#). The volume of the fuel tank shall be sufficient for 24 h of unattended operation and in addition for the above required duration of emergency operation (SOLAS).

### Note

*For a cargo ship intended for unrestricted service is a fuel oil supply tank required with a capacity sufficient for 42 h of operation (24 h of unattended operation in port as a port diesel generator set and additional 18 h operation as an emergency diesel generator set). The level alarm has to be arranged at a level sufficient for not less than 18 h of operation. If the fuel oil supply tank is arranged for automatically refilling, the amount of fuel oil for 24 h of operation is not required.*

### **D.3 Operation manual**

An operation manual shall be provided on board containing the conditions for the operation and ensure that when the vessel is under way all control devices (e.g. valves, switches) are in a correct position for the independent emergency operation of the emergency generator set and emergency switchboard.

#### **Note**

*This operation manual shall also contain information on required fuel oil tank level, position of harbour/ sea mode switch if fitted, ventilation openings, etc.*

## Section 4 Installation Protection and Power Distribution

A	Three-Phase Main Generators .....	4-1
B	Emergency Three-Phase Generators .....	4-3
C	Direct Current Generators.....	4-4
D	Power Transformers .....	4-4
E	Storage Batteries .....	4-4
F	Power Electronics .....	4-5
G	Shore Connection .....	4-5
H	Consumer Protection Equipment.....	4-5
I	Power Distribution.....	4-6

### A Three-Phase Main Generators

#### A.1 General

The main generators supply the relevant main switchboard, either individually or in parallel.

##### A.1.1 Single operation

Single operation means that each generator supplies a busbar system assigned to it. Where this method is used, it shall be possible to connect the consumers or consumer groups to at least two different busbar systems or generators by means of selector switches.

##### A.1.2 Parallel operation

In parallel operation, the generators supply a common busbar system of the main switchboard, to which the consumer feeders are connected.

#### A.2 Protection equipment

##### A.2.1 General

**A.2.1.1** Generators shall be at least protected against damage due to short circuits and overloads.

**A.2.1.2** Protection equipment for generators is to be arranged within the switchgear field of the generator to be protected and supplied from the generator side.

**A.2.1.3** Short-circuit protection and overload protection equipment is to be provided in every non-earthed conductor.

##### A.2.2 Short-circuit protection

**A.2.2.1** The short-circuit protection is to be set at an overcurrent of more than 50 %, but at a value less than the steady short-circuit current (preferably  $2.8 \times I_n$ ). It shall have a short time delay compatible with the selectivity of the system (from 300  $\mu$ s to about 500 ms).

**A.2.2.2** The short circuit protection shall not be disabled by undervoltage.

**A.2.2.3** Generators with a rated output of 1500 kVA or more are to be equipped with a suitable protective device which in the event of a short circuit inside the generator or in the cable between generator and circuit-breaker opens the breaker and de-energises the generator.

Examples of suitable protective equipment are differential protection or generator-neutral-point monitoring.

### **A.2.3 Overload protection**

**A.2.3.1** The overload protection, which is to be set to a value between 10 % and 50 % overcurrent, shall trip the generator circuit breaker with a time delay of not more than 2 minutes. A setting above 50 % overcurrent may be allowed, where this is required by the working conditions and is compatible with the generator characteristics. The overload protection shall not impair immediate reconnection of the generator.

**A.2.3.2** A device shall be installed which, when the generator's rated current is exceeded, cause a warning signal after about 5 s and automatically disconnects the non-essential and if necessary the secondary essential equipment, excluding those required for maintaining ship's safety, e.g. lighting systems, position and navigating lights, aids and signals and internal safety communication equipment.

On passenger ships and ships with unattended machinery spaces the automatic disconnection of non-essential consumers is mandatory.

### **A.2.4 Reverse-power protection**

**A.2.4.1** Generators from 50 kVA output upwards provided for parallel operation are to be protected by a delayed reverse-power release.

**A.2.4.2** The protection shall be selected and set in accordance with the characteristics of the prime mover. Setting guidance values are: for turbo-generators 2 % to 6 %, for diesel generators 8 % to 15 % of the rated output delayed from 2 to 5 seconds. The setting should, if possible be at 50 % of the tractive power of the prime mover. Should the operating voltages decrease to 50 % of the rated value, the reverse-power protection shall remain effective within the limits stated.

### **A.2.5 Undervoltage protection**

Generator circuit-breakers are to be provided with under-voltage protection. In the event of a decrease of the voltage to 70 % – 35 % of the rated voltage, the generator circuit-breaker shall open automatically. Undervoltage releases shall have a short-time delay adapted to the short circuit protection.

### **A.2.6 Over-voltage protection**

The ship's mains shall be protected against over-voltage. The overvoltage protection shall be adjusted not higher than 130 %  $U_N$  and 5 s.

### **A.2.7 Underfrequency protection**

**A.2.7.1** In the event of a continuous frequency drop of more than 10 %, the non-essential and, where necessary, the secondary essential equipment shall be tripped within 5 to 10 s. If this fails to establish normal operating condition, the supplying generators shall be disconnected from the power supply so that the stand-by unit can cut in.

**A.2.7.2** For shaft-driven generator plants protection shall be provided in accordance with [Section 3, B.4](#) for disconnecting the generators in the event of under-frequency.

### **A.2.8 Testing**

Generator protection devices are subject to mandatory type approvals.

## **A.3 Switchgear**

### **A.3.1 General**

**A.3.1.1** Each non-earthed conductor shall be switched and shall be protected against short circuit and overload.



**A.3.1.2** When tripped due to overcurrent, generator circuit breakers shall be ready for immediate re-connection. The use of thermal bi-metallic release for generators used to supply essential consumers is not permitted.

**A.3.1.3** Generator circuit breakers shall be provided with a reclosing inhibitor which prevents automatic reclosure after tripping due to a short circuit.

**A.3.1.4** In the design of the contactor to supply primary essential consumers the low voltage switching devices shall be dimensioned in accordance with IEC publication 60947-4-1 "type 2".

**A.3.1.5** Is the personnel security ensured and the selective protection of the electrical system by devices in series guaranteed in this case the low voltage switching devices for supplying secondary essential and less important consumers could be dimensioned in accordance with IEC publication 60947-4-1 "type 1".

### **A.3.2 Single operation**

The following devices are to be provided:

- a three-pole circuit breaker with time-delayed overcurrent- and short-time-delayed short-circuit release.
- for generators with a rated output below 50 kVA, fuses and load switches or fuses with contactors are also permitted.

All generator contactors that may be used are to be provided with a dropout delay (up to approx. 500 ms) and shall be rated for double of the generator current.

### **A.3.3 Parallel operation**

The following devices are to be provided:

- For each generator, a three-pole circuit breaker with delayed overcurrent- and short-time-delayed short-circuit and undervoltage release
- In the case of generators intended for parallel operation, the generator switch is to be provided with undervoltage protection which prevents closing of the switch if the generator is dead.
- A single-fault event in the synchronisation circuit or in the black-out monitoring shall not lead to an asynchronous connection.

## **A.4 Synchronizing equipment**

Generators intended for parallel operation shall be equipped with a synchronizer in accordance with [A.4.1](#) and [A.4.2](#).

### **A.4.1 Equipment to prevent faulty synchronizations**

Generators intended for parallel operation shall be provided with automatic synchronizing equipment. Instead of automatic equipment, semiautomatic synchronizing equipment combined with a check synchronizer may be provided. The conditions of [Section 20, E](#) shall be complied with in order to prevent faulty synchronization.

### **A.4.2 Manual synchronization**

Manual synchronization (e.g. synchronizing dark method installed within sight of the generator-switch actuating position) shall be possible if the appliances listed in [A.4.1](#) fail.

## **B Emergency Three-Phase Generators**

Emergency generators supply the emergency switchboards and the connected emergency consumers.

### **B.1 Protective equipment and switchgear**

Generator protection shall consist of at least:

- short circuit protection
- overload protection
- undervoltage protection.

However it is permissible for the overload protection not to disconnect the generator automatically but instead to trigger an optical and acoustical warning signal at the emergency switchboard and at the main switchboard.

## **B.2 Overload shedding**

If the emergency generator is overloaded, consumers temporarily supplied from the emergency switchboard which are not emergency consumers shall be automatically disconnected in order to safeguard the supply to the emergency circuits.

## **C Direct Current Generators**

### **C.1 Single operation**

The following devices are to be provided:

- For each generator, a circuit breaker which simultaneously switches all non-earthed poles, with a delayed overcurrent release and a short-time-delayed short-circuit release, or a fuse in each non-earthed pole and a spring-operated load-switch with sufficient breaking capacity.
- Circuit breakers are always to be used for generators with outputs of 50 kW and over.

### **C.2 Parallel operation**

The following facilities are to be provided:

- For each generator, a circuit breaker which simultaneously switches all non-earthed poles, with a delayed overcurrent release and a short-time-delayed short-circuit release, together with a reverse-current protection and short-time-delayed undervoltage protection.
- For compound generators, the switch shall contain a switching element for the equipotential line which, when switching on, closes simultaneously or earlier and, when switching off, opens simultaneously or later, and is rated for at least half the rated current.
- A polarity-reversing facility for each generator.

## **D Power Transformers**

**D.1** Transformers intended for parallel operation shall be so designed that over the whole load range the load on no transformer deviates by more than 10 % of its nominal current from the percentage share calculated for it.

**D.2** Transformers shall be protected against short circuit and overload.

**D.3** Transformers shall be switchable on the primary side.

In installations where feedback is possible transformers shall be switchable at both, the primary and secondary side.

## **E Storage Batteries**

[Section 2, C](#) is to be observed.

## **F Power Electronics**

**F.1** Power electronics facilities are to be protected against overload and short circuits.

**F.2** Inverters intended for the supply of emergency consumers from the emergency battery shall be designed for continuous operation.

## **G Shore Connection**

**G.1** Terminal boxes for shore supply shall be linked to the ship's system by permanently laid cables.

**G.2** A device for connecting a protective conductor or a potential equalizer has to be provided, if required.

**G.3** Switching-on of the shore supply shall only be possible if the switches of the main generators have been shut-off. Short-term parallel operation of the ship's mains and the shore mains for load transfer is permissible.

**G.4** The shore connection shall be switchable and it shall be protected against short circuit and overload.

The terminal box for shore connection shall be provided at least with short-circuit protection.

**G.5** A voltage indicator shall be provided in the main switchboard.

**G.6** Facilities shall be provided to compare the polarity (in the case of direct current) and the phase sequence (in the case of three-phase alternating current) of the shore supply with those of the ship's mains.

**G.7** The following details shall be indicated on a plate fitted to the shore connection box: voltage system and rated voltage, and the frequency in the case of alternating current.

## **H Consumer Protection Equipment**

### **H.1 General**

**H.1.1** Protective equipment shall be so selected and co-ordinated with the generator protection that in the event of a short circuit the selectivity is safeguarded. If necessary the evidence is to be proved.

**H.1.2** Every non-earthed conductor in a distribution circuit shall be protected against overload and short circuit.

**H.1.3** Where the three phase system is isolated from the hull the over current protection can be realised in only 2 conductors, if the disconnection of all phases is safeguarded.

### **H.2 Final supply circuits**

#### **H.2.1 Circuit breakers and motor protection switches**

For a final circuit supplying one consumer with its own overload protection, it is permissible to provide short-circuit protection only at the input point. In this case, fuses two ratings higher than those permissible for rated operation of the consumer may be used for continuous duty.

In the case of short-time and intermittent operation, the rated current of the fuses shall not be greater than 160 % of the rated current of the consumer. The associated switches are to be selected in accordance with the fuse current ratings.

**H.2.2** Where circuit breakers are used, the short-circuit cutout may be adjusted to a maximum of 15 times the rated current of the consumer, though not higher than the anticipated minimum value of the initial short-circuit alternating current in the circuit concerned. For steering gear equipment circuits, see [Section 7, A](#).

**H.2.3** Circuit breakers and motor protection switches with insufficient switching capacity shall be fitted with the back-up fuses specified by the manufacturer. Automatic circuit breakers without a selectively graded breaking delay may not be connected in series in a single line.

**H.2.4** Final supply circuits for lighting shall not be fused above 16 A.

Regarding the number of lighting fixtures connected to a circuit see [I.5](#).

## I Power Distribution

### I.1 Electrical supply systems

**I.1.1** Regarding permissible supply systems see [Section 1, G](#).

#### I.1.2 Supply systems with hull return

**I.1.2.1** All final supply circuits shall have all-pole insulation. The return conductors are to be connected in the associated distribution switchboard to an insulated busbar, which is connected to the hull.

**I.1.2.2** The connections to the hull shall have at least the same cross-section as the supply cable.

Bare wires shall not be used. Casings or their mounting bolts shall not be used as return conductors or to make their connection.

**I.1.3** Up to 3 distribution switchboards may be supplied by a common supply cable.

### I.2 Load balancing in three-phase systems

Where, in three-phase systems, AC-consumers are connected between two outer conductors or one outer conductor and the neutral, the consumers are to be distributed in such a way that, under normal operating conditions, the loads on the individual outer conductors do not differ from each other by more than 15 % see [Section 12, C.5](#).

### I.3 Essential supply cables

**I.3.1** Primary and secondary essential equipment shall be preferably supplied direct from the main- or emergency switchboard in accordance with the Rules. Supply via distribution panels is only permissible if an equivalent safety of supply is guaranteed, see [Section 2, A.3](#).

**I.3.2** Primary and secondary essential equipment for the same function (e.g. main and stand-by lubricating oil pumps) are to be fed via two separate cables from the main switchboard or from two independent sub-distribution panels.

Exempt from this request are central power supplies for cargo refrigeration plants on refrigerated cargo vessels and systems for cargo maintaining on gas tankers.

Regarding supply to steering gear see [Section 7, A](#).

## **I.4 Emergency supply cables**

**I.4.1** Emergency consumers shall be supplied directly from the emergency switchboard or via sub-distribution panels, to which only consumers in the relevant fire zone are connected.

**I.4.2** In normal operation, the emergency switchboard shall be supplied by an interconnection feeder from the main switchboard. The feeder is to be protected against overcurrent and short circuits at the main switchboard, and the feeder shall be automatically disconnected in the emergency switchboard if the supply from the main switchboard fails.

**I.4.3** A return supply from the emergency switchboard to the main switchboard, e.g. when starting operation from dead ship condition or under observance of [Section 3, D](#) for harbour operations, is permitted. For return supply operation, the automatic feeder disconnection called for in [I.4.2](#) may be temporarily overridden.

## **I.5 Supply of lighting systems**

**I.5.1** Main lighting installations shall be supplied from the main switchboard, emergency lighting installation from the emergency switchboard.

**I.5.2** The number of lighting points (lamps) connected to one final circuit shall not exceed:

10 lamps for voltages up to	55 V
14 lamps for voltages over	55 V
24 lamps for voltages over	125 V

**I.5.3** Switches shall simultaneously switch all non-earthed conductors. Single-pole switching of final circuits for lighting in systems with all conductors insulated is permitted only in the accommodation area.

**I.5.4** Sockets outside the accommodation area shall be connected to separate circuits. When calculating the permissible connected load, one socket is equivalent to two lighting points.

**I.5.5** In the areas listed below, the lighting shall be supplied by at least two separate fused circuits:

- main engine rooms, service spaces and control stations
- large galleys
- passageways and alleys
- stairways leading to the boat deck
- saloons and lounges for passengers and crew
- pump rooms on tankers

**I.5.6** The lighting fixtures shall be so arranged that sufficient illumination for orientation is maintained should one circuit fail.

## **I.6 Navigation- and signalling lights**

**I.6.1** The masthead -light, sidelights- and stern light are separate to be supplied from the navigation lights controller. Each circuit shall be protected against overload and short circuit.

Masthead light(s), sidelights and a sternlight shall be duplicated or be fitted with duplicate lamps on ships with 50 m in length and above.

The individual main- and reserve lights may have separate circuits in a common cable.

**I.6.2** The navigation lights controller may be extended for the supply of the signalling lights specified in the "International Regulations for Preventing Collisions at Sea (COLREGs)".

Other consumers shall not be connected to this panel.

Section 4 Installation Protection and Power Distribution

---

**1.6.3** Navigation- and signal light controller shall be supplied from the main- and emergency electrical power source. An automatic switch over to the alternative source of power is permitted and to be alarmed.

**1.6.4** An navigation lights controller should facilitate ON/OFF controls of individual Navigation lights.

**1.6.5** An navigation lights controller should provide visual indications of "ON"/"OFF" status of Navigation lights.

**1.6.6** Pre-programmed navigation lights group settings may be provided.

**1.6.7** The navigation lights controller shall be provided with a device for each light which gives optical and acoustical alarm if the light disappears.

Where the monitoring device is connected in series with the navigation light, it shall be ensured that a failure of the device does not cause the navigation light to disappear.

**1.6.8** An navigation lights controller shall present the status of all navigation lights in a logical presentation, meeting the requirements set out in IMO Resolution MSC.191(79).

**1.6.9** All indicators of an navigation lights controller shall be dimmable. The brightness of a display, if fitted, shall be controllable.

**1.6.10** To prevent shortage of luminous intensity of LEDs (Light Emitting Diodes) an alarm function should be activated to notify the Officer of the Watch that the luminous intensity of the light reduces below the level required by COLREGs or LEDs shall only be used within the lifespan (practical term of validity) specified by the manufacturer to maintain the necessary luminous intensity of LEDs. The specifications in the certificate of conformity for navigation lights are to be observed.

**1.6.11** Where navigation lights are supplied from the main source of electrical power, the voltages at the lamp-holders shall not permanently deviate by more than 5 % above or below the rated voltage.

Where, in the event of a failure of the main electric power, navigation lights are supplied from the emergency source of electrical power, the voltages at the lamp-holders may temporarily deviate by up to 10 % above or below the rated voltage.

## **1.7 Control-, monitoring- and ship's safety systems**

The supply of control-, monitoring- and ship's safety systems shall comply with the following requirements (see additionally [Section 9, B](#)):

**1.7.1** These systems shall be supplied by their own circuits.

Provision shall be made for the selective disconnection of the separate circuits in case of a short circuit.

**1.7.2** A common distribution network with back-up batteries may be used to supply systems which are required to remain operative even if the main source of electrical power fails. Such a network shall have two supply units comprising either:

**1.7.2.1** a power supply unit with a capacity sufficient for all the connected consumers together with a charger which, acting in buffer operation with the back-up battery, is capable of supplying continuously all the connected consumers and maintain the battery in the charged condition or

**1.7.2.2** two chargers, which meet the conditions stated in [1.7.2.1](#).

**1.7.3** With regard to residual ripple, the supply facilities specified in [1.7.2.1](#) and [1.7.2.2](#) shall be designed to ensure trouble-free operation of the connected systems even when the battery is temporarily disconnected.

**1.7.4** One of the power supply units or chargers shall be supplied directly from the main switchboard.

**1.7.5** Failure of the power supply units and chargers shall be signalled visually and audibly.

**1.7.6** Battery chargers with a charging capacity of  $P \geq 2$  kW shall be tested at the maker's works in the presence of a Surveyor.

### **1.8 Emergency shutdown facilities**

Emergency shutdown facilities placed outside the sites at which the equipment is installed are to be provided for the following consumers. The consumers may be arranged in groups, provided that redundant consumers are allocated to at least two electrically independent groups.

Emergency shutdown facilities are to be provided for e.g.

- fuel pumps
- lubrication oil pumps
- oil burner plants
- separators
- fan motors
- boiler blowers
- auxiliary blowers for main engines
- thermal oil pumps

(see the GL Rules for [Machinery Installations \(I-1-2\)](#), [Section 12, B.9](#))

### **1.9 Radio and navigational equipment**

#### **1.9.1 General**

The main- and emergency electrical power sources shall at any time maintain a sufficient supply of power to operate the radio equipment and to charge all reserve power sources for the radio equipment.

**1.9.1.1** The radio and navigational equipment shall be directly supplied from both the main source of electrical power and the emergency source of electrical power by separate power supply circuits.

**1.9.1.2** The power distribution for radio equipment shall be independent of that for the navigational equipment. The circuits from both the main and the emergency source of electrical power shall be terminated either in one or two distribution panels. If one distribution panel is used, the two circuits supplying the panel shall be provided with splitter feeding into two separate bus bars, one for the radio equipment and one for the navigational equipment. The panel(s) shall be located at the navigating bridge or other suitable position on the bridge deck.

**1.9.1.3** Facilities shall be provided in each distribution panel for changing over between the main source of electrical power and the emergency source of electrical power. It is preferable that change over be initiated automatically. If a single distribution panel is used for both the radio and the navigational equipment, separate change over switches shall be provided.

**1.9.1.4** Failure of any power supply shall initiate an alarm at the navigational bridge.

#### **1.9.2 Radio equipment**

**1.9.2.1** A reserve source or sources of energy shall be provided to supply radio equipment, for the purpose of conducting distress and safety radio communications, in the event of failure of the ship's main and emergency sources of electrical power.

**1.9.2.2** Further stipulations for the reserve source of energy are to be taken from the **SOLAS** Convention, Chapter IV and relevant IMO guidelines.

#### **1.9.3 Navigational equipment**

Where radio equipment requires an uninterrupted input of information from the ship's navigational equipment, it will be necessary for the equipment providing the data to be supplied from the same distribution board bus bar serving the radio equipment.

### **I.10 Sound signalling system**

The ship's sound signalling system shall remain operative if the electrical main power supply fails.



## Section 5 Low-Voltage Switchgear Assemblies

A	General .....	5-1
B	Calculations .....	5-1
C	Construction .....	5-3
D	Selection of Switchgear .....	5-6
E	Choice of Electrical Protection Equipment.....	5-8
F	Conductors and Busbar Carriers .....	5-10
G	Measuring Instruments and Instrument Transformers.....	5-12
H	Testing of Switchboards and Switchgear.....	5-13

### A General

**A.1** These Rules apply to low-voltage switchgear with operating voltages of up to 1000 V AC or 1500 V DC.

**A.2** Electrical installations are to be protected against damage due to overloading and short circuit.

**A.3** The thermal- and electro-dynamic stresses due to overcurrents shall not cause damage to parts of the installation during the response time of protective devices or during the total operating time of switches.

**A.4** Overcurrent protective devices are to be selected on the basis of the following criteria:

- overload current
- short-circuit current
- reclosing capability

**A.5** Regarding design, construction and testing of low-voltage switchgear assemblies attention is drawn to IEC publication 60092-302.

**A.6** For further notes see [Section 4](#).

### B Calculations

#### B.1 Calculation of short-circuit currents

**B.1.1** Short-circuit current calculations are to be carried out in accordance with a standard accepted by GL, e.g. IEC publication 61363-1.

#### Note

*A computer-backed calculation program is obtainable from GL. The CD - ROM version of the GL Rules GL - RP includes the calculation program.*

**B.1.2** When calculating the maximum short-circuit currents to be expected, the following are to be taken into account:

- all generators which operate in parallel to provide the maximum power demand
- all motors whose simultaneous operation shall be expected.

All data used for the short-circuit current calculation are to be submitted.

To be determined are:

- the peak short-circuit current  $i_p$
- the initial symmetrical short-circuit current  $I''_k$

**B.1.3** Roughly, the short-circuit currents at the main busbar can be calculated as follows:

$$\mathbf{B.1.3.1} \quad I''_{kG} = \frac{I_{rG} \cdot 100}{x_d''(\%)}$$

$I''_{kG}$  = initial symmetrical short-circuit current of a generator

$I_{rG}$  = rated current of the generator

$x_d''$  = subtransient reactance of the generator in per cent

$$\mathbf{B.1.3.2} \quad I''_{kM} = 6 \cdot I_{rM}$$

$I''_{kM}$  = initial symmetrical short-circuit current of a motor

$I_{rM}$  = rated current of the motor

**B.1.3.3** The total initial symmetrical short-circuit current can be calculated by summation of the individual component currents.

**B.1.3.4** The value of the peak short-circuit current  $i_p$  can be calculated by multiplying the total initial symmetrical short-circuit current  $I''_k$  by the factor 2.3.

**B.1.4** The short-circuit calculation shall consider all possible short circuits necessary for an evaluation of the system. The following types of short circuits are to be investigated in all cases:

- generator short-circuits
- short-circuits on main busbars
- short-circuits on the busbars of emergency switchboards and main distribution panels

**B.1.5** The short-circuit current calculation shall be accompanied by a list of the proposed switching devices and their characteristic data.

The rated making capacity, the rated breaking capacity and the power factor of the switching appliances shall be stated.

**B.1.6** GL reserve the right also to request proof of the minimum short-circuit currents to be expected.

## **B.2 Heat losses (heat balance)**

Switchgear assemblies shall be so designed that under operational conditions the permissible temperature rise limits in accordance with IEC publication 60092-302 are not exceeded.

GL reserve the right to request proof of the heat balance.

## **B.3 Dynamic and thermal loading**

**B.3.1** Switchgear assemblies shall be so designed that no permanent damage to busbars, busbar mountings and the wiring is caused by the dynamic and thermal loading arising in the event of a short circuit.

GL reserve the right to request proof of the dynamic and thermal stability in the event of a short circuit.

**B.3.2** For systems with a peak current above 220 kA ( $I_{pk}$ ) evidence shall be given for the rated peak withstand current ( $I_{pk}$ ) and the rated short-time withstand current ( $I_{cw}$ ) by a test according to IEC publication 61439-1 Paragraph 9.3 or equivalent standard.

## C Construction

### C.1 General

**C.1.1** All devices, instruments and operating devices shall be permanently identified by name plates. Wherever possible, clear text shall be used. Fuse current ratings are to be stated. The setpoints of adjustable protective devices are to be marked. The rated operating parameters of all measuring instruments shall be marked in red either on the scales or on plates fixed nearby.

**C.1.2** All screwed joints and connections shall be secured against self-acting loosening.

**C.1.3** All conductors shall be secured jig-proof and are to be kept away from sharp edges. Conductors leading to equipment mounted in doors are to be laid tension-free.

**C.1.4** Main and emergency switchboards shall be fitted with insulation hand rails or handles.

**C.1.5** All components including their connections have to be accessible for the purposes of maintenance, repair and replacement.

**C.1.6** Large doors in switchboards shall be fitted with arresting devices.

**C.1.7** Electrical components mounted in the doors of switchboards, e.g. switchgear, measuring devices and fuses for voltages over 50 V, shall be safeguarded against accidental contact. Such doors are to be earthed.

**C.1.8** Where fuses are fitted above switchgear or bare connecting wires or leads, measures are to be taken to ensure that falling parts (e.g. fuse cartridges) cannot come into contact with live components.

**C.1.9** Operating devices and fuses shall be safely accessible.

**C.1.10** For circuit breakers and load-switches, the minimum distances above the arc chutes specified by the manufacturers are to be maintained.

**C.1.11** Knife-type fuses for supply-circuits are only permitted if they can be safely withdrawn and inserted.

### C.2 Main switchboards

**C.2.1** Observation of the measuring and indicating devices and operation of the switchgear shall be possible from the front side of the switchboard with the doors closed.

**C.2.2** If the total installed power of all generators exceeds 3 MW, the generator panels shall be separated from each other by arc-resistant partitions. Busbar penetrations shall be flame-retardant and self-extinguishing.

**C.2.3** In plants where the main source of electrical power is necessary for the propulsion of the ship, the main busbar shall be capable to be subdivided into at least two parts which shall normally be connected by circuit breakers or other approved means.

Other approved means can be achieved by:

- circuit breaker without tripping mechanism; or
- disconnecting link or
- switch

by which bus bars can be split easily and safely. Common bolted links between single busbar or switchboard sections (e.g. for transportation) do not fulfil these requirements.

**C.2.4** A single disconnecting device is sufficient if this device is provided within separate switchboard panel without other installations or in an equivalent bounded section, see Fig. 5.1. Otherwise two disconnecting devices are required in different switchboard panels, see Fig. 5.2.

**C.2.5** In case of removable or movable links, these devices shall be easily accessible and simple to handle. Tools for operating shall be located nearby.

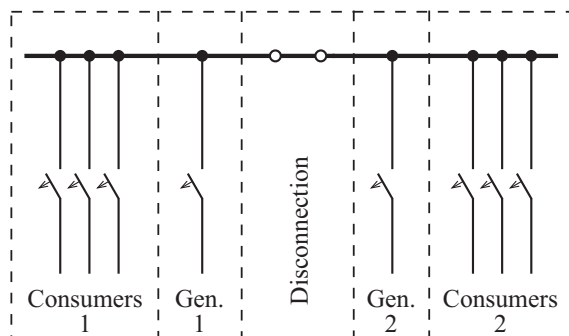

**Fig. 5.1** Example for arrangement of a main busbar disconnection and division of consumers

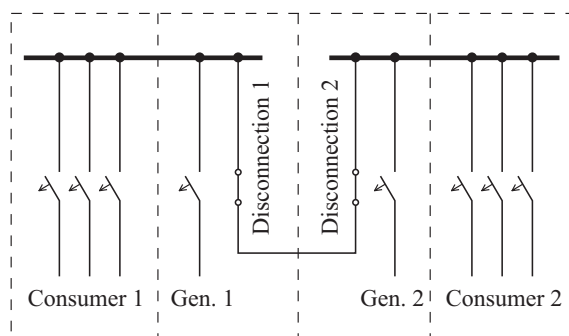

**Fig. 5.2** Example for arrangement of two disconnecting devices and division of consumers

**C.2.6** As far as is practicable, the connection of generating sets and other duplicated consumers shall be equally divided between the main bus bar sections.

**C.2.7** The consumers may, for instance, be grouped as follows:

<b>Consumers 1</b>	<b>Consumers 2</b>
Lubricating oil pump 1	Lubricating oil pump 2
Cooling water pump 1	Cooling water pump 2
Lighting 1	Lighting 2
etc.	etc.

**C.2.8 Switchgear and synchronizing equipment for generators**

See Section 4, A

**C.2.9 Measuring and monitoring devices for generators**

**C.2.9.1** Where circuit breakers are used, the following shall be provided:

- 1 indicating light: circuit breaker connected
- 1 indicating light: circuit breaker released

**C.2.9.2** The following is required for each three-phase alternator:

## Section 5 Low-Voltage Switchgear Assemblies

---

- 1 voltmeter which can, if necessary, be switched to the other alternators
- 1 ammeter, switchable to all phases
- 1 active power meter for alternators of 50 kVA and over
- 1 frequency meter which can, if necessary, be switched to the other alternators

**C.2.9.3** The following are required for each direct-current generator:

- 1 voltmeter
- 1 ammeter

**C.2.9.4** The following circuits shall be supplied from the generator side, and shall be separately protected against short circuits:

- generator protection devices, and the undervoltage trip of the generator circuit breaker
- measuring instruments
- indicating lights
- diesel engine speed-adjusting equipment

(The power supply from the governor could be used, if an electronically governor is installed, see [Section 9, B.8.3.](#))

- motor drive for circuit breaker

**C.2.9.5** A manual operation is to provide for generator circuit breaker. It shall be independent and overriding, see [Section 21, D.3.4 e](#)).

### **C.2.10 Switchgear and fuses for equipment**

**C.2.10.1** Each supply line run from the main switchboard shall be provided with a circuit breaker with overcurrent and short-circuit protection, or with a fuse for each non-earthed conductor and an all-pole switch, or with a contactor with control switch. Where fuses and switches are used, the sequence busbar-fuse-switch is to be used. The specified sequence may be changed where motor switches of utilization category AC-23 A are used as load switches, provided that the switches are weldproof in the event of a short circuit (see [B.3](#)).

The rated peak withstand current (dynamic limiting current) of switches shall be greater than the cut-off current of the associated fuse in the event of a short circuit.

**C.2.10.2** For steering gear, see also [Section 7, A](#).

### **C.2.11 Measuring instruments**

The main switchboard and the main distribution panel have to be fitted with ammeters for major consumers, unless these are already mounted on the consumers themselves. It is permissible for one ammeter to be switched-over to a number of circuits.

## **C.3 Emergency switchboards**

**C.3.1** The requirements for main switchboards apply in analogous manner to emergency switchboards.

**C.3.2** Control and supply circuits of the emergency electrical power plant shall be so switched and protected that interruptions or short circuits caused by fire or another event,

- in a space housing the main generators and/or the main switchboard, or
- in a category A machinery space

do not impair the operating ability of the emergency source of electrical power. Where necessary, the emergency switchboard has to be fitted with isolating switches.

## C.4 Distribution panels

**C.4.1** Distribution panels are to be equipped with the necessary devices for the protection of the connected circuits and for the supply of consumers (see [Section 4](#)).

**C.4.2** Feeder circuits with fuses shall be switched with load switches. In the case of feeder circuits with fuses up to 63 A, load switches may be dispensed with if each connected equipment can be disconnected by a switch fitted nearby.

**C.4.3** For navigation lanterns panel, see [Section 4, I.6](#).

**C.4.4** Distribution panels for the supply of power to container sockets, see [Section 11, C.4](#).

## C.5 Motor starters

**C.5.1** Each motor shall be provided with its own switching device.

**C.5.2** It shall be indicated whether the motor is switched on.

**C.5.3** If the switching device does not disconnect all of the live conductors, additional measures are to be taken for the protection of personnel.

**C.5.4** Motors are to be provided with starters if:

- currents or voltage drops higher than those permissible for the system are liable to occur, if connected directly
- this is necessary for the start-up of the motor or the driven machine
- this is required by the design of the generators.

**C.5.5** Starting shall only be possible from the zero position of the starter.

## D Selection of Switchgear

### D.1 General

**D.1.1** Switchgear shall conform to IEC publications, or to another standard approved by GL.

**D.1.2** Switchgear shall be selected with regard to its rated current, its rated voltage, its thermal and dynamic stability and its switching capacity.

The following shall be observed:

**D.1.2.1** The rated short-circuit making capacity shall be not less than the calculated peak short-circuit current  $i_p$  at the place of installation.

**D.1.2.2** The rated service short-circuit breaking capacity shall be not less than the a.c. component of the short-circuit  $I_{ac}(t)$  at the moment

$$t = \frac{T}{2}$$

### Note

See also [B.1](#), *short-circuit currents calculation*.

## **D.2 Circuit breakers**

**D.2.1** Circuit breakers are distinguished according to the utilization categories of IEC publication 60947-2 into:

### **D.2.1.1 Utilization category A**

These are circuit-breakers not designed for selectivity under short-circuit conditions with respect to other short-circuit protective devices in series on the load side, e.g. without intentional short-time delay for selectivity under short-circuit conditions, and therefore do not need proof of the rated short-time withstand current ( $I_{cw}$ ).

Application example:

As consumers circuit-breakers and distribution feeders.

### **D.2.1.2 Utilization category B**

These are circuit-breakers which are designed for selectivity under short-circuit conditions with respect to other short-circuit protective devices in series on the load side, e.g. with intentional short-time delay for selectivity under short-circuit conditions. Such circuit-breakers shall have proof of the rated short-time withstand current ( $I_{cw}$ ). Utilization category B circuit breakers shall be able to withstand the short-circuit current to be expected where they are fitted, for the duration of at least 500 ms.

Application example:

As generator circuit-breakers.

**D.2.2** Additional requirements for generator circuit breakers:

- Following tripping due to an overcurrent, the breaker shall immediately be ready for re-closing. For this reason thermal tripping devices are not permitted.
- A reclosing block shall prevent automatic remaking of the breaker onto a still persisting short circuit following tripping due to a short circuit.

**D.2.3** Additional requirement for circuit breakers in IT systems:

- Testing as described in Annex H of IEC 60947-2 is required.

## **D.3 Load switches**

**D.3.1** The current rating of load switches shall be at least equal to that of the fuse protecting the circuit and they shall have a making/breaking capacity in accordance with AC-22 A or DC-22 A (IEC publication 60947-3).

**D.3.2** The sequence busbar - fuse - switch should be maintained.

**D.3.3** If the sequence busbar - switch - fuse is chosen, the making/breaking capacity shall match category AC-23 A or DC-23 A (IEC publication 60947-3) and attention is to be paid to increased insulation qualities of the switching unit.

## **D.4 Fuses**

**D.4.1** Fuse links shall have an enclosed fusion space. They shall be made of ceramic or other material recognized by GL as equivalent.

**D.4.2** Fuses may be used for overload protection only up to a rating of 315 A.

Exceptions to this Rule are subject to approval by GL.

## **E Choice of Electrical Protection Equipment**

### **E.1 General**

Protective devices shall be co-ordinated with each other in such a way that, in the event of a fault, the defective circuit is disconnected and the power supply to essential equipment is maintained.

### **E.2 Short-circuit protection equipment**

**E.2.1** The rated short-circuit breaking capacity  $I_{cn}$  of a switching device shall not be less than the maximum current to be broken in the event of a short circuit at the place where the protective device is fitted.

**E.2.2** The rated short-circuit making capacity  $I_{cm}$  of a circuit breaker shall not be less than the maximum instantaneous asymmetric short-circuit current at the place where it is fitted.

**E.2.3** The peak short circuit strength of a switching unit and its components shall correspond to the maximum short-circuit current which can arise at the place where it is fitted.

**E.2.4** Circuit breakers whose making/breaking capacities are less than the anticipated maximum short-circuit currents are to be protected by back-up fuses of sufficient breaking capacity.

**E.2.5** The circuit breakers are to be selected on the basis of their rated service short circuit breaking capacity  $I_{cs}$  as follows:

- all circuit breakers which are directly connected to main or emergency switchboard
- all circuit breakers which are installed in the feeder lines for essential services or emergency consumers

Equivalent protection schemes require special approval by GL.

### **E.3 Selective arrangement**

**E.3.1** The short-circuit protection of essential equipment shall be selective and shall ensure that only the switching device nearest to the fault initiates disconnection of the defective circuit. For this purpose:

- the tripping time of protective devices connected in series shall be carefully coordinated
- the switching devices being capable of carrying the short-circuit current during the total break time of the device plus the time lag required for selectivity
- Exceptions may be permitted in the case of circuits feeding redundant plants or non-essential equipment if selectivity relative to the generator switch is maintained.

### **E.4 Overcurrent protection devices**

The current-time characteristics of overcurrent protection devices shall be compatible with the system components to be protected, and with the requirements of selectivity.

### **E.5 Allocation of short-circuit and overcurrent protection devices**

**E.5.1** Short-circuit protection is required for every non-earthed conductor.

**E.5.2** Overcurrent protection is required for at least one conductor in insulated direct-current and single-phase alternating-current circuits.

Overcurrent protection is required for at least two phases in insulated, load-balanced three-phase circuits.

**E.5.3** Overcurrent protection is required for each non-earthed conductor in earthed systems. The continuity of earthed conductors shall not be interrupted by short-circuit or overcurrent protection devices, except in the case of multipole disconnection devices which simultaneously interrupt all the conductors, whether earthed or not.



**E.5.4** Determined for the overcurrent protection of the entire circuit (switchgear, switchboard wiring, supply cables and equipment) according to regulations is the rated current  $I_n$  of the connected equipment or in the case of grouped supply cables the evaluated total rated current.

## **E.6 Motor protection**

**E.6.1** Motors with a power rating of more than 1 kW shall be individually protected against overloads and short circuits. For steering-gear motors, see [Section 7](#).

**E.6.1.1** The protective devices shall be compatible with the mode of operation of the motors and shall provide reliable protection against thermal overload.

**E.6.1.2** If the current/time characteristic of the overload protection device does not correspond to the starting conditions of a motor, provision may be made to suppress operation of the device during the start-up period. The short-circuit protection shall remain operative.

**E.6.2** The switchgear of motors whose simultaneous restarting on restoration of the supply voltage might endanger operation shall be provided with undervoltage protection which prevents automatic re-start.

**E.6.3** Where necessary, the start-up of motors which are required to restart automatically following restoration of the voltage is to be staggered in such a way that the starting currents do not overload the ship's mains.

## **E.7 Control circuits**

**E.7.1** The control circuits of essential systems shall be independent of other control circuits.

**E.7.2** Common control circuits for groups of consumers are permitted only when this is required by functional relationships.

**E.7.3** For emergency shutdowns, see [Section 4, I.8](#).

**E.7.4** Control-power transformers shall be protected against short circuit and overload. Fuses may be used on the secondary side as overload protection. Where the rated current on the secondary side is less than 2 A, the overload protection may be omitted.

**E.7.5** Switching elements shall not be located in the earthed part (N) of an earthed control circuit.

## **E.8 Measuring and signalling circuits**

Current loops for signalling and measuring equipment and also indication lamps shall be protected against short circuit and overload in each non-earthed conductor.

Excepted are indicating lamps with operating voltage  $\leq 24$  V or if measures are taken to prevent influence on control and power circuits in case of short circuit.

## **E.9 Exciter circuits**

Exciter circuits and similar circuits whose failure could endanger operation may be protected only against short circuit.

## **E.10 Monitoring of insulation resistance**

Each non-earthed primary or secondary system serving power, heating or lighting installations shall be fitted with an equipment which monitors the insulation resistance relative to the ship's hull and gives an optical and audible alarm if the insulation resistance value is abnormally low (see also [Section 20, E](#)).

For tankers, see [Section 15](#).

Insulation monitoring devices may be dispensed with in the case of secondary systems such as control circuits.

### E.11 Testing of protection devices for generators and large consumers on board

Electronic or computerised protection devices for generators and large consumers shall be so designed that the function of the protection equipment can be tested on board, see [Section 10](#).

Especially attention to:

- arrangements to readily identification of the last final settings, in the event of possible change
- facilities and instructions for testing the settings and functions on board

## F Conductors and Busbar Carriers

### F.1 Busbars, bare or painted

#### F.1.1 General

**F.1.1.1** Busbars shall be made of copper or copper-plated aluminium, or corrosion-resistant aluminium.

**F.1.1.2** The dimensions of main busbars and section busbars made of copper shall conform to [Table 5.1](#) as a function of their permitted load.

The temperature rise shall not exceed 45 K and shall not have any harmful effect on adjacent components.

**F.1.1.3** Parallel-run busbars of the same phase are to be installed not less than one bar thickness apart. Earth conductors, neutral conductors of three-phase mains and equalization lines between compound-wound generators shall have at least half the cross-section of the phase conductor.

#### F.1.2 Connections to equipment

Cross-sections of connection bars and wires to equipment shall be of such size as to avoid thermal overloading of the equipment at full load as well as in the event of a short-circuit.

**Table 5.1 Permissible loading of copper main busbars and section busbars of rectangular cross-section at 45 °C ambient temperature (45 K temperature rise)**

Width × Thickness  [mm]	Maximum permissible loading [A] with 50/60 Hz							
	painted (matt-black)				bare			
	Number of bars				Number of bars			
	1 	2 	3 	4 	1 	2 	3 	4 
15 × 3	230	390	470	–	200	350	445	–
20 × 3	290	485	560	–	250	430	535	–
20 × 5	395	690	900	–	340	620	855	–
20 × 10	615	1145	1635	–	530	1020	1460	–
25 × 3	355	580	650	–	300	510	615	–
25 × 5	475	820	1040	–	405	725	985	–
30 × 3	415	670	735	–	350	590	700	–
30 × 5	555	940	1170	–	470	830	1110	–
30 × 10	835	1485	2070	–	710	1310	1835	–
40 × 5	710	1180	1410	–	595	1035	1350	–

Section 5 Low-Voltage Switchgear Assemblies

40 × 10	1050	1820	2480	3195	885	1600	2195	2825
50 × 5	860	1410	1645	2490	720	1230	1560	2380
50 × 10	1260	2130	2875	3655	1055	1870	2530	3220
60 × 5	1020	1645	1870	2860	850	1425	1785	2740
60 × 10	1460	2430	3235	4075	1220	2130	2850	3595
80 × 5	1320	2080	2265	3505	1095	1795	2170	3370
80 × 10	1860	2985	3930	4870	1535	2615	3460	4275
100 × 10	2240	3530	4610	5615	1845	3075	4040	4935
120 × 10	2615	4060	5290	6360	2155	3545	4635	5580
160 × 10	3348	5121	6646	7836	2752	4451	5803	6857
200 × 10	4079	6162	7973	9287	3335	5344	6956	8109

**Note**

*The maximum permissible loading applies to switchboards not closed at the rear. In the case of fully enclosed switchboards adequate ventilation is to be ensured, or the loading values stated are to be reduced.*

**F.2 Busbar carriers**

Busbars are to be mounted in such a way that they withstand the stresses caused by short-circuit currents and maintain the required clearance and creepage distances relative to other voltage-carrying or earthed components.

**F.3 Clearance and creepage distances**

**F.3.1** The values indicated in [Table 5.2](#) apply to main busbars and the associated non-fused connection bars for main, emergency and control switchboards.

**Table 5.2 Clearance and creepage distances**

Rated service voltage [V] (AC/DC)	Minimum clearance [mm]	Minimum creepage distance [mm]
≤ 125	10	12
> 125 ≤ 250	15	20
> 250 ≤ 690	20	25
> 690	25	35

**F.3.2** Lower values than those indicated in [Table 5.2](#) may be approved by GL if the following conditions are met:

- switchgear of standard design
- QM-system approved by GL
- reduction of pollution by appropriate installation and degree of protection
- GL type-approved switchboard system

**F.4 Insulated wires**

**F.4.1** Insulated wires shall be of the stranded type, and shall satisfy the requirements for cables and wires set out in [Section 12](#). The cross-section of the conductor shall be at least sufficient for the rated current of the connected equipment. Conductors are to be selected in accordance with [Table 5.3](#).

**F.4.2** Non-fused conductors leading from the main busbar to fuses and circuit breakers shall be as short as possible, but not longer than 1 m.

**Table 5.3 Current rating of wires in switchgear**

Nominal cross-section of conductor - total cross-section in the case of conductors connected in parallel  [mm <sup>2</sup> ]	Bunched, exposed or in conduits		Wires run singly, at least one conductor diameter apart  Circuits of all kinds  Current [A]
	Several power circuits together  Current [A]	One power circuit together with its associated measuring and control wires  Current [A]	
1	9	12	15
1.5	12	15	19
2.5	16	20	25
4	20	27	34
6	26	35	42
10	36	48	58
16	48	65	78
25	66	86	102
35	82	107	125
50	104	133	157
70	130	164	194
95	157	198	231
120	186	231	272

**Note**

The current ratings shown applies to conductors with a maximum permissible operating temperature [T] on the conductor of 70 °C and an ambient temperature of 45 °C. For conductors with a maximum permissible operating temperature [T] deviating from 70 °C, the current rating is to be determined by applying the correction factor [F].

<b>T</b>	60 °C	65 °C	70 °C	75 °C	80 °C	85 °C
<b>F</b>	0.77	0.89	1.00	1.10	1.18	1.26

**F.4.2.1** These wires shall not be run and mounted together with other wires.

**F.4.2.2** Control wires for essential equipment shall be so run and protected that they may not be damaged by short-circuit arcs.

## **G Measuring Instruments and Instrument Transformers**

### **G.1 Measuring instruments**

**G.1.1** The measuring error of switchboard instruments shall not exceed 1.5 % of the full scale value. Instruments with directional response are to be used for DC generators and batteries.

**G.1.2** Voltmeters shall have a scale range of at least 120 % of the rated voltage, and ammeters a scale range of at least 130 % of the maximum anticipated continuous-service current. Ammeters are to be so rated that they are not damaged by motor starting currents.

**G.1.3** The scale range of power meters shall be at least 120 % of the rated power. For generators connected in parallel, the scale range shall also register at least 15 % reverse power. Where power meters have only a single current path, all generators shall be measured in the same phase. If the total value of all consumers connected to a single phase exceeds 10 % of the power of the smallest generator, the

power meters shall be equipped with multiple movements in order to record the unbalanced load on the outer conductors.

**G.1.4** Frequency meters shall be capable of registering deviations of  $\pm 5$  Hz from the rated frequency.

## **G.2 Instrument transformers**

**G.2.1** Instrument transformers shall conform to class 1 as a minimum requirement.

**G.2.2** Current transformers for protective devices shall not exhibit a current error of more than 10 % in the expected overcurrent range.

# **H Testing of Switchboards and Switchgear**

## **H.1 Type-approvals**

The following devices and components are subject to mandatory type approval:

- circuit breakers, load-switches, disconnect-switches and fuses for direct connection to the main busbars and to non-fused, multi-terminal busbars of main-, emergency- and control switchboards
- generator protection devices
- standardized switchgear in series manufacture with reduced clearance and creepage distances (see [F.3.2](#))

## **H.2 Tests in manufacturer's works**

**H.2.1** All switchboards are to be tested in the manufacturer's works.

**H.2.2** The following are subject to testing in the presence of a GL Surveyor:

- main switchboards
- emergency switchboards
- distribution switchboards with connected power  $\geq 500$  kW
- all switchboards for cargo-refrigeration systems covered by Class Notation **CRS**
- switchboards for electrical propulsion plants
- starters and controls for steam boiler and thermal oil systems

GL reserve the right to stipulate a factory test for other switchboards.

## **H.2.3 Scope of tests**

### **H.2.3.1 Visual inspection**

Checking of manufacture against the approved drawings. The components and materials used shall conform to the Rules.

### **H.2.3.2 Functional test**

Testing of functional performance on the basis of a test schedule and the approved drawings, as far as is feasible.

### **H.2.3.3 High-voltage test**

The test voltage specified in [Table 5.4](#) and [Table 5.5](#) is to be applied between the conductors, and between the conductors and the switchboard frame. The duration of the test is one minute in each case.

Measuring instruments and other auxiliary apparatus may be disconnected during test.

- Test voltage for main circuits

Section 5 Low-Voltage Switchgear Assemblies

---

- For main circuits the test has to be carried out with the values according to [Table 5.4](#).
- Test voltage for auxiliary circuits
- For auxiliary circuits the test has to be carried out with the values according to [Table 5.5](#).
- Test voltage for type-approved switchgear

For the verification of dielectric property of type-approved switchgear the test voltage for routine tests may be reduced to 85 % of the values according to Table 5.4 and Table 5.5.

#### H.2.3.4 Insulation resistance measurement

The voltage test is to be followed by measurement of the resistance of insulation. The insulation resistance measurement is to be performed at a DC voltage of at least 500 V.

In large installations, the switchboard may be divided into a number of test sections for this purpose. The insulation resistance of each section shall be at least 1 MΩ.

**Table 5.4 Test voltage for main circuits**

Rated insulation voltage $U_i$ DC and AC [V]	Test voltage (AC) (r.m.s) [V]
$U_i \leq 60$	1000
$60 < U_i \leq 300$	2000
$300 < U_i \leq 690$	2500
$690 < U_i \leq 800$	3000
$800 < U_i \leq 1000$	3500
$1000 < U_i \leq 1500$ <sup>1</sup>	3500

<sup>1</sup> Only for DC voltage

**Table 5.5 Test voltage for auxiliary circuits**

Rated insulation voltage $U_i$ DC and AC [V]	Test voltage (AC) (r.m.s) [V]
$U_i \leq 12$	250
$12 < U_i \leq 60$	500
$U_i > 60$	$2 U_i + 1000$ , but at least 1500

## Section 6 Power Electronics

A	General .....	6-1
B	Construction .....	6-1
C	Rating and Design .....	6-1
D	Cooling .....	6-2
E	Control and Monitoring .....	6-3
F	Protection Equipment .....	6-3
G	Tests .....	6-3

### A General

For power electronics in electrical propulsion plants, see [Section 13](#).

### B Construction

**B.1** The rules set out in [Section 5](#) are to be observed, wherever applicable.

**B.2** Each power-electronics system shall be provided with separate means for disconnection from the mains.

In the case of consumers up to a nominal current of 315 A the combination fuse-contactor may be used. In all other cases a circuit breaker shall be provided on the mains side.

**B.3** Equipment shall be readily accessible for purposes of measurement and repair. Devices such as simulator circuits, test sockets, indicating lights, etc. are to be provided for functional supervision and fault location.

**B.4** Control- and alarm electronics shall be galvanically separated from power circuits.

**B.5** External pulse cables are to be laid twisted in pairs and screened, and kept as short as possible.

### C Rating and Design

**C.1** Mains reactions of power electronics facilities shall be taken into consideration in the planning of the overall installation, see [Section 1, F](#) and [K](#).

**C.2** Rectifier systems shall guarantee secure operation even under the maximum permissible voltage and frequency fluctuations, see [Section 1, F](#). In the event of unacceptably large frequency and/or voltage variations in the supply voltage, the system shall shut-off or remain in a safe operating condition.

**C.3** For the supply of mains, number and rating of electronic facilities is to be so scaled that in the event of failure of any one power-electronics facility the remainder of the installation is sufficient to:

- feed all essential equipment which may be in simultaneous operation with the propulsion plant at full power

- start the biggest consumer without exceeding the maximum permissible voltage and frequency variations.

To maintain the required availability, bypass switching may be resorted to.

**C.4** The semiconductor rectifiers and the associated fuses shall be so selected that their load current is at least 10 % less than the limit current determined in accordance with the coolant temperature, the load and the mode of operation.

**C.5** The permissible periodic peak blocking voltage of the individual component shall be greater by a factor of at least 1.8 than the peak value of the undistorted supply voltage. This value may be reduced for static converter circuits with separate power supplies.

**C.6** Electrical charges in power electronic modules shall drop to a voltage of less than 50 V in a period of less than 5 s after disconnection from the mains supply. Should longer periods be required for discharge, a warning label is to be affixed to the appliance.

**C.7** If the replacement of plug-in printed circuit boards while the unit is in operation can cause the destruction of components or the uncontrolled behaviour of drives, a caution label shall be notifying to this effect.

**C.8** The absence of external control signals, e.g. due to a circuit break, shall not cause a dangerous situation.

**C.9** Control-circuit supplies are to be safeguarded against unintended disconnection, if this could endanger or damage the plant.

**C.10** It is necessary to ensure that, as far as possible, faults do not cause damage in the rest of the system, or in other static converters.

**C.10.1** Special attention shall be paid to the following points:

- mutual interference of static converters connected to the same busbar system
- calculation of commutating impedances reacting to voltage distortion and reacting to other consumers
- the selection of the ratio between the subtransient reactance of the system and the commutating reactance of the static converter
- consideration of reactions from rectifier installations on the commutation of DC machines
- consideration of voltage drops in the ship's mains due to inverter operation
- influence by harmonics and high-frequency interference
- influence on the ship's mains by energy feeding back

**C.10.2** Where filter circuits and capacitors are used for reactive current compensation, attention is to be paid to the following:

- reaction on the mean and peak value of the system voltage in case of frequency fluctuations
- inadmissible effects on the voltage regulation of generators

## **D Cooling**

**D.1** Natural cooling is preferred.

**D.2** The safety in operation shall be proved for liquid cooling and forced cooling.



**D.3** An impairment of cooling shall not result in unacceptable overtemperatures, an overtemperature alarm shall be provided.

## **E Control and Monitoring**

**E.1** Control, adjustment and monitoring shall ensure that the permissible operating values of the facilities are not exceeded.

**E.2** The power supply to all control circuits shall be monitored for voltage failure.

**E.3** For the monitoring of individual modules and assemblies of essential equipment, components shall be provided which in the event of a fault facilitate its recognition.

**E.4** The control shall be so engineered that the installation is protected from damage during the switching-on and switching-off sequence, dedication alterations and faulty operation.

## **F Protection Equipment**

**F.1** Power electronic equipment shall be protected against exceeding of their current and voltage limits.

For protective devices, it shall be ensured that upon actuating

- the output will be reduced or defective part-systems will be selectively disconnected
- drives will be stopped under control
- the energy stored in components and in the load circuit cannot have a damaging effect, when switching off.

**F.2** In equipment with a current rating of more than 100 A, each bridge arm or parallel-connected valve shall have a special semiconductor fuse. Exceptions are quenching circuits in self-regulating systems and converters operated with a load-independent current. For all other equipment, fuses on the input/output side may also be used.

**F.3** Special semiconductor fuses shall be monitored. After tripping the equipment has to be switched off, if this is necessary for the prevention of damage.

Activating of a safety device shall trigger an alarm.

**F.4** Equipment without fuses is permissible if a short circuit will not lead to the destruction of the semiconductor components.

## **G Tests**

### **G.1 General**

**G.1.1** Power electronics assemblies shall be individually tested at the maker's works. A Works Test Report shall be rendered on the tests carried out. Essential equipment from 50 kW/kVA upwards shall be tested in the presence of a GL Surveyor.

**G.1.2** It is assumed that the requirements of environmental conditions as defined in [Section 1, E](#) and for electro-magnetic compatibility as defined in [Section 1, K](#) are fulfilled. GL is entitled to request proof of the relevant parameters, if applicable.

## **G.2 Extent of routine tests**

### **G.2.1 Voltage test**

Prior to the start of the functional tests a high-voltage test shall be carried out. The RMS value of the alternating test voltage is:

$$U = 2 U_n + 1000 \text{ V, duration 1 minute}$$

but at least 2000 V, where  $U_n$  is the maximum nominal voltage between any two points on the power electronics device.

For this purpose, switchgear in power circuits shall be bridged, and the input and output terminals of the power electronics devices and the electrodes of the rectifiers shall be electrically connected with each other. The test voltage shall be applied between the input/output terminals or between the electrodes and:

- the cabinet
- the mains connection side, if the power electronics device is electrically isolated from the mains

### **G.2.2 Test of insulation resistance**

Following the voltage test, the insulation resistance shall be measured at the same connections as for the voltage test. The measurement shall be performed at a voltage of at least 500 V DC.

### **G.2.3 Operational test**

The function shall be demonstrated as far as possible.

### **G.2.4 Testing of protection and monitoring devices**

The response thresholds and the coordinated operation of the protective and monitoring devices shall be demonstrated.

## Section 7 Power Equipment

A	Steering Gear.....	7-1
B	Lateral Thrust Propellers and Manoeuvring Aids .....	7-5
C	Variable Pitch Propellers for Main Propulsion Systems .....	7-6
D	Auxiliary Machinery and Systems.....	7-6
E	Deck Machinery .....	7-9
F	Electrical Heating Equipment and Heaters .....	7-10
G	Heel-Compensating Systems .....	7-10
H	Cross-flooding Arrangements .....	7-10

### A Steering Gear

#### A.1 General

**A.1.1** Every ship shall be provided with two as far as possible independent steering gear systems, as follows:

- 1 main and 1 auxiliary steering gear
- on every tanker, chemical tanker or gas carrier of 10000 GT and upwards and in every other ship of 70 000 GT with 1 main steering gear with two or more identical power units
- on every passenger ship with 2 main steering gears

Where electrical or electro-hydraulic steering gear is installed, the following Rules are to be observed.

**A.1.2** The design of main and auxiliary steering gears shall conform to **SOLAS**, Chapt. II-1, Part C, Reg. 29 and 30, and to the GL Rules set out in [Machinery Installations \(I-1-2\), Section 14, A](#).

**A.1.3** The electrical systems of main and auxiliary steering gears shall be so designed that a failure in one of them shall not affect the operation of the other. This also applies when the main steering gear comprises two or more identical power units, and an auxiliary steering gear need not therefore be provided under the **SOLAS** regulations.

**A.1.4** On every tanker, chemical tanker or gas carrier greater than 10 000 GT the main steering gear system shall be so arranged that in the event of loss of steering capability due to a single failure in any part of the power actuating systems of the main steering gear, excluding the tiller, quadrant or components serving the same purpose, or seizure of the rudder actuators, steering capability shall be regained in not more than 45 s after the loss of one power actuating system. The isolation of the defect part of the system shall be done by automatic means.

**A.1.5** For increased vibration loads in the steering gear compartment, see [Section 1, E](#).

#### A.2 Power supply

**A.2.1** The power supply to steering gears is also required to comply with the provisions of [Section 4, I](#).

**A.2.2** A separate power supply circuit from the main switchboard is to be provided for each steering gear power unit.

After an electrical power failure, the steering gear power units shall restart automatically when the power is restored.

**A.2.3** On ships with a calculated rudderstock of more than 230 mm in diameter (see the GL Rules for [Machinery Installations \(I-1-2\), Section 14, A.4.1](#)), without ice strengthening, an alternative power source additional to the main power source is required, which is capable of supplying the steering gear in such a way that this is able to perform at least the duties of an auxiliary steering gear. It shall also supply the steering gear control system, the remote control of the power unit and the rudder-angle indicator. In addition, the alternative power source shall be automatically connected within 45 s after a power failure. This power source may be the emergency generator set, or an independent power source intended only for this purpose and situated in the steering gear compartment, and shall maintain operation:

- for 10 minutes on ships of up to 10 000 GRT and
- for 30 minutes on ships of 10 000 GRT and over.

**A.2.4** The system is to be so designed that it is possible, from the bridge or the steering gear compartment, to put each power unit into operation. Mechanically separated switches are to be provided for this purpose.

The supply of the bridge remote control for the power units shall be run from the associated switchgear in the steering gear compartment – same as steering gear control system – and shall be made for its disconnection without any accessories.

For supplies to the steering gear control systems, see [A.6](#).

### **A.3 Design of the electric drives**

**A.3.1** To determine the torque characteristics required for electric motors of power units, account is to be taken of the breakaway torque and the effective maximum torque of the steering gear under all operating conditions (see the GL Rules for [Machinery Installations \(I-1-2\), Section 14, A.4](#)).

**A.3.2** The following requirements apply to the modes of operation:

**A.3.2.1** Steering gear with intermittent power demand:

- S 6 - 25 % for converters and the motors of electro-hydraulic drives
- S 3 - 40 % for the motors of electromechanical steering gears

The ratio of pull-out torque to rated torque is to be at least 1.6 in all cases.

**A.3.2.2** Steering gear with constant power demand:

- S 1 - 100 % continuous service

**A.3.3** For the motor design, see [Section 20](#).

### **A.4 Switchgear**

**A.4.1** Each steering gear motor shall have its own separate switchgear. Combined contactor cabinets are not permitted.

Each steering gear motor shall have an ammeter mounted in the main or emergency switchboard, as applicable, or in the contactor cabinets.

**A.4.2** The remote control systems of the power units and the rudder control shall be capable of being disconnected or isolated inside the contactor cabinets (e.g. by removal of the fuse-links or switching off the automatic circuit breakers). These switches or fuses are to be specially marked.

### **A.5 Protection equipment**

**A.5.1** The circuits for the control systems and motors of steering gears are to be protected only against short circuits.

**A.5.2** Where fuses are used, their current ratings shall be two steps higher than the rated current of the motors. However, in the case of intermittent-service motors, the fuse rating shall not exceed 160 % of the rated motor current.

**A.5.3** Protection equipment against excess current, including starting current, if provided, is to be required to be not for less than twice the rated current of the motor so protected. Steering gear motor circuits obtaining their power supply via an electronic converter and which are limited to full load current are exempt from above requirement.

**A.5.4** The instantaneous short-circuit trip of circuit breakers shall be set to a value not greater than 15 times the rated current of the drive motor.

**A.5.5** The protection of control circuits shall correspond to at least twice the maximum rated current of the circuit, though not, if possible, below 6 A.

## **A.6 Steering gear control systems**

**A.6.1** Ships with electrically operated steering gear controls shall have two independent steering gear control systems. Separated cables and wires are to be provided for these control systems.

A common steering wheel or a common tiller may be used.

**A.6.2** If a follow-up (FU) control system and a non-follow-up (NFU) control system are provided, each of these systems shall be able to operate on each power unit. Switching of the control systems shall be possible on the bridge.

Where two identical control systems are installed, each control system can be permanently assigned to a power unit.

If a follow-up control system is installed on the bridge wing, then the follow-up tiller shall be fitted with a retaining spring to midship position, or a take-over arrangement shall be installed on bridge wings.

**A.6.3** Provision shall be made for operating the main and auxiliary steering gear from the bridge and the steering gear compartment.

**A.6.4** The power supplies to the electrical steering gear control systems shall be taken from the power unit supplies in the steering gear compartment, or from the corresponding power unit feeders in the main or emergency switchboard (see [A.2.4](#)).

**A.6.5** The electrical separation from each other of the steering gear control systems shall not be impaired by the addition of extra systems, such as autopilot systems.

**A.6.6** For change-over between different control systems a common control selector switch may be provided. The circuits of the various control systems shall be arranged electrically and physically separated.

**A.6.7** On ships where an automatic control system like heading- or track control system is installed, an override facility shall be installed close to the operator unit of the automatic steering system. The Override facility shall be so designed that self-induced return to automatic control is not possible except where the heading preselection of the automatic system is automatically kept in line. The switch-over from automatic- to manual control by "Override" is to be indicated optically and audibly at the steering position. The override facility shall be independent of the automatic control system or follow-up control mode.

**A.6.8** Different steering modes including steering gear control positions on the bridge wings shall be changed over by all poles, when it cannot be verified that it is free of reactive effects. Portable steering consoles are to be connected via plugs with pin coding. It is necessary to ensure that the rudder-angle indicator can be read within the range of operation of the portable steering console.

**A.6.9** Repeaters and limit switches - if provided - shall be linked electrically and mechanically to the respective control system and mounted separately to the rudder stock or the adjusting devices.

## **A.7 Alarms and indicators**

**A.7.1** Alarms and indicators for steering gears and controls are to be gathered from [Table 7.1](#).

**A.7.2** Depending on the rudder characteristic, critical deviations between rudder order and response shall be indicated visually and audibly as actual steering mode failure alarm on the navigating bridge. The following parameters shall be monitored:

- Direction: actual rudder position follows the set value;
- Delay: rudder's actual position reaches set position within defined time limits;
- Accuracy: the end actual position shall correspond to the set value within the design offset tolerances.

**A.7.3** The alarms/indicators listed in [Table 7.1](#) shall be signalled visually and audibly irrespective from the automation equipment.

Alarms and indicators on the bridge shall be announced at a position close to main steering station.

**A.7.4** In case of fixed relation between control system and power unit the alarms No. 2 and No. 5 of [Table 7.1](#) may be grouped.

**A.7.5** The energy supply for the alarms and indicators shall be in accordance with [A.2](#)

## **A.8 Rudder-angle indicator**

See [Section 9, C.4](#)

## **A.9 Tests**

**A.9.1** For the testing of electrical motors, see [Section 20](#).

**A.9.2** The following monitoring devices are subject to mandatory type approval:

- phase-failure detection
- level switches

**A.9.3** Steering gear control systems with all components important for the function are subject to a mandatory type approval, e.g.:

- steering mode selector switch
- follow-up (FU) / non-follow-up (NFU) control devices
- rudder angle feedback units, incl. lever drive

**Table 7.1 Alarms and indicators of steering gear and controls**

No.	Alarms/indicators	Main and auxiliary steering gear	
		Bridge	Engine room
1	Operation of power unit	×	×
2	Power failure of power unit/control	×	⊗
3	Overload of electric drive or phase failure of supply	×	⊗
4	Low level of hydraulic oil tank	×	⊗
5	Power failure of steering control system	×	⊗
6	Hydraulic lock	×	⊗
7	Failure actual steering mode	×	⊗

### **Note**

× = *Single indication, see also [A.7.3](#)*

⊗ = *Group indication*

## **A.10 Control of steering propeller systems for main propulsion units**

### **A.10.1 Control of the direction of thrust**

The requirements of [A.6](#) shall be applied in an appropriate manner.

### **A.10.2 Monitoring and testing**

The requirements of [A.7](#) and [A.9](#) shall be applied in appropriate manner.

### **A.10.3 Indicator**

The effect on the course shall be indicated. The regulations in [Section 9, C](#) shall be applied in appropriate manner.

## **B Lateral Thrust Propellers and Manoeuvring Aids**

These Rules apply to equipment with electrical drive.

### **B.1 Rating**

Manoeuvring aids shall generally be rated for continuous duty.

Drives used only for lateral thrust shall be designed at least for short-term duty S 2 - 30 min at all speeds.

### **B.2 Protection equipment**

**B.2.1** The equipment shall be protected in such a way that, in the event of an overcurrent, an audible and visual warning is first given on the bridge, followed by an automatic power reduction or disconnection of the system if the overload persists. The audible warning shall be acknowledgeable on the bridge. For plants with automatic current limitation the warning is not required.

**B.2.2** If fuses are used for short-circuit protection, a phase-failure supervision is required to prevent the system to be started if one phase fails.

**B.2.3** It shall be ensured that, if a lateral thrust propeller stalls, the main power supply to the drive is disconnected quickly enough to avoid endangering the selectivity of the system with regard to the generator switchgear.

**B.2.4** Motors for short-term duty shall be monitored for critical winding temperature. An exceeding of temperature limits shall be alarmed. If the maximum permissible temperature is reached the output shall be automatically reduced or the motor shall be switched off.

### **B.3 Controls, monitors and indicators**

**B.3.1** For lateral thrusters, the main steering station on the bridge shall be provided with the following indicators:

- an indicating light showing that the system is ready for operation
- an indicating light signalling an overload (for systems without power control)
- depending on the type of equipment, indicators showing the power steps and the desired direction of motion of the ship

**B.3.2** Indications and alarms in the engine room or engine control room:

Faults which may cause failure or endanger the drive shall be signalled optically and audibly as collective alarms.

An ammeter for the drive motor shall be provided at the main switchboard.

**B.3.3** The direction of movement of the controls of lateral thrust units shall correspond to the desired direction of motion of the ship. Power for the electrical control system shall be taken from the main power supply to the drive.

**B.3.4** There shall be an emergency stop at every control station, which affects the feeder breaker in the main switchboard.

## **C Variable Pitch Propellers for Main Propulsion Systems**

**C.1** The design and operation of these systems shall conform to the Rules for [Machinery Installations \(I-1-2\)](#), [Section 6](#).

**C.2** Provision shall be made to enable the system to be controlled from the bridge and from the engine room.

Failure of the control system shall be signalled optically and audibly on the bridge and in the engine room.

**C.3** From the main steering station on the bridge it shall be possible to isolate completely any additional electrical remote-control facilities provided on the open deck (e.g. on bridge-wings).

**C.4** Input- and output units and actuating devices shall be type-tested.

## **D Auxiliary Machinery and Systems**

### **D.1 Fire-extinguishing systems**

#### **D.1.1 Fire pumps**

**D.1.1.1** The power supply to the motors and the fire-pump control systems are to be so arranged with regard to the assignment of sources of power, the routing of the power-supply cables and the location of the controls that a fire in any main fire zone cannot render all the fire pumps unserviceable (see also the GL Rules for [Machinery Installations \(I-1-2\)](#), [Section 12, E.1](#)).

**D.1.1.2** If remote starting is provided for fire pumps, pump controls shall be so designed that in the event of failure of the remote control the local control remains operative. Regarding remote starting of fire pumps on ships with unattended engine room see [Automation \(I-1-4\)](#).

**D.1.1.3** A bypass shall be provided, if fire pumps have a soft starter.

#### **D.1.2 Pressure water spraying systems (Sprinkler)**

For the design of these systems, see also the GL Rules for [Machinery Installations \(I-1-2\)](#), [Section 12, L](#).

**D.1.2.1** Pressure water spraying systems shall be supplied from the main and from the emergency source of electrical power.

**D.1.2.2** The design of the fire-alarm system shall be acc. to the requirements of [Section 9, D](#).

**D.1.2.3** The switches at the main and emergency switchboards required for the power supply to all units forming part of the alarm- and extinguishing systems shall be clearly marked.

**D.1.3** For cable laying, see [Section 12, D.1](#).



## **D.2 Fans**

**D.2.1** On cargo ships power-driven fans for accommodation, service spaces, cargo spaces, control stations and machinery rooms shall be capable of being switched off from an easily reachable position as safe from fire as possible and located outside the spaces to be ventilated.

The switches for switching off the machinery space ventilation shall be separated from the switches for switching off the other fans. See [Section 4, I.8](#).

**D.2.2** It is recommended that one of the engine room fans should be supplied from the emergency source of electrical power to enable the extraction of fire-extinguishing gases, should the need arise. Due to this recommendation the requirements of [Section 5, C.2.6](#) are to be observed.

**D.2.3** Regarding fans for passenger ships, see [Section 14](#).

## **D.3 Fuel pumps and separators**

Controls shall be provided to enable the electric motors of fuel pumps and fuel and lubricating oil separators to be stopped from outside the spaces concerned. See [Section 4, I.8](#).

## **D.4 Pumps discharging overboard**

The motors of pumps discharging overboard and whose outlets are located in the lifeboat launching area above the light waterline shall be equipped with switches next to the launching station of the lifeboats.

## **D.5 Turning gear**

**D.5.1** See also the GL Rules for [Machinery Installations \(I-1-2\), Section 1, D.9](#).

**D.5.2** The remote control of electrically driven turning gear shall be so designed that the gear motor stops immediately, if the switch or pushbutton is released.

**D.5.3** An disconnect switch shall also be fitted near the drive unit.

**D.5.4** The turning gear shall be equipped with a device which prevents the diesel engine from being started as long as the turning gear is engaged.

## **D.6 Electric starting equipment for main and auxiliary engines**

### **D.6.1 General**

**D.6.1.1** Regarding additional requirements for diesel engine starting equipment see the GL Rules for [Machinery Installations \(I-1-2\), Section 2, H](#).

**D.6.1.2** The starter batteries shall only be used for starting (and preheating where applicable) and for the monitoring equipment and controller associated with the engine.

Maintaining and monitoring of the charge-condition of the batteries is to be ensured.

### **D.6.2 Main engines**

If main engines are started electrically, two starter batteries mutually independent are to be provided. They shall be so arranged that they cannot be connected in parallel. Each battery shall be capable of starting the main engine from cold condition.

The total capacity of the starter batteries shall be sufficient for the following number of starting operations to be carried out within 30 minutes without recharging:

- reversible main engines:
  - 12 combined reversal and starting operations
- non-reversible main engines:
  - 6 starting operations

### **D.6.3 Auxiliary engines**

#### **D.6.3.1 Main generator sets**

If several auxiliary engines are started electrically, at least two mutually independent batteries shall be provided. The use of the main engine starter batteries, if there are any, is permitted.

The capacity of the batteries shall be sufficient for at least three starting operations per engine.

If only one of the auxiliary engines is started electrically, one battery is sufficient.

#### **D.6.3.2 Emergency generator sets**

- a) Each emergency generator set that has to be started automatically shall be equipped with a GL-approved starting device with sufficient power for at least three successive starting operations even at an ambient temperature of 0 °C.

If starting is impossible at this temperature or if lower temperatures are likely to be encountered, heating shall be provided to ensure starting of the generator sets.

Additionally a second source of energy is to be provided capable of three further starting operations within 30 minutes. This requirement can be cancelled if the set can also be started manually.

- b) To guarantee availability of the starting devices it is to be ensured that:
- electrical and hydraulic starter systems are supplied from the emergency switchboard
  - compressed-air starter systems are supplied via a non-return valve from the main and auxiliary compressed-air or by an emergency air compressor supplied with power via the emergency switchboard
  - the starting, charging and energy storage equipment is located in the emergency generator room.

These equipment is intended for the operation of emergency generator sets only and shall not be used for other purposes.

- c) If automatic starting is not a requirement, starting equipment which ensures safe manual starting is permitted, e.g. by hand-crank, spring-powered starter, manual hydraulic or ignition cartridge starter.
- d) If a direct start by hand is not possible, starting devices as in a) and b) shall be provided, manual initiation of the starting process is acceptable.
- e) If a second source of starting energy is a mechanical starting facility, an electronical speed governor, associated protection devices and valves shall have a back-up power supply independent of the first source of starting energy. This back-up source shall be monitored.
- f) If mechanical starting facilities are provided, an electronical speed governor, associated protection devices and valves shall have two independent back-up power supplies. These back-up sources shall be monitored.

#### **D.6.3.3 Emergency fire extinguishing sets**

If manual starting by hand crank is not possible, the emergency fire extinguishing set shall be equipped with a GL-approved starting device capable of at least 6 starting operations within 30 minutes, two of them carried out within the first 10 minutes, even at an ambient temperature of 0 °C.

### **D.7 Standby circuits for consumers**

**D.7.1** Standby circuits shall be provided for the reciprocal operation of consumers with the same function. Changeover to another unit due to a fault shall be signalled optically and audibly.

**D.7.2** Automatically controlled groups of consumers shall be so structured that a fault in one group does not affect the functioning of other groups.

## **E Deck Machinery**

### **E.1 General**

#### **E.1.1 Type of enclosure**

The degree of protection for motors and switchgear shall be selected in accordance with [Section 1, Table 1.10](#).

#### **E.1.2 Emergency shut-down**

Lifting gear shall be equipped with an emergency switch which allows to stop the drive immediately, should the control system fail. Brakes shall be released automatically if the power supply fails.

#### **E.1.3 Control equipment**

Levers and handwheels for the control of lifting equipment shall return automatically to the zero position when released. Exceptions may be allowed for trawl winches and for special-purpose drives.

### **E.2 Anchor windlasses and capstans**

#### **E.2.1 Rating of motors**

Motors shall be rated in accordance with the GL Rules for [Machinery Installations \(I-1-2\), Section 14, D.4](#) for short- term duty (S. 2 - 30 min), unless the kind of operation for which the ship is intended imposes more stringent demands.

The motors shall be able to deliver 1.6 times the rated torque for 2 minutes without dangerous overheating.

#### **E.2.2 Overload protection**

To prevent excessive overloading of the motors and, as far as possible, the gears, electrical overload protection shall be provided as follows:

- Unless the motor is not protected against overheating by winding temperature monitoring, a time-delayed overcurrent protection shall be provided, which in case of overload causes shut-off of the motor after 2 minutes of operation at 1.5 times the rated torque.
- In addition, an electromagnetic release shall be fitted which is so adjusted that the drive is disconnected when the maximum torque of the anchor windlass is attained. Tripping may be delayed for up to about 3 s in the case of three- phase motors. The device shall be connected in such a way that, after tripping, the motor can be restarted only from the zero position.

The electromagnetic release may be dispensed with if the clutch and transmission gears are made so strong that jamming the windlass does not cause any damage.

- The electromagnetic release is not required in electrohydraulic drives where the maximum torque is limited by a safety valve.

### **E.3 Cargo winches and cranes**

Reference is made to the GL [Loading Gear on Seagoing Ships and Offshore Installations \(VI-2-2\)](#).

### **E.4 Free fall lifeboat launching equipment**

If the secondary launching appliance is not dependent on gravity, stored mechanical power or other manual means, the launching appliance shall be connected both to the ship's main and emergency power supplies. According LSA Code, Chapter VI, 6.1.4.7.

The connection box shall be provided with automatically power change-over and shall be installed close to the launching equipment.

## **F Electrical Heating Equipment and Heaters**

### **F.1 Space heating**

**F.1.1** Space heaters shall be designed and mounted in such a way that combustible components are not ignited by the heat generated. They shall not suffer damage due to overheating.

**F.1.2** For reasons of fire protection, particular attention shall be paid to the special instructions regarding the fitting and mounting of each unit.

**F.1.3** For the construction of this equipment, see [Section 20, J.2](#).

### **F.2 Oil and water heaters**

These are subject to the provisions of [Section 20, J](#). and the GL Rules for [Machinery Installations \(I-1-2\)](#), [Section 7](#) and [7b](#).

## **G Heel-Compensating Systems**

**G.1** The system shall be centrally controlled and monitored. The following facilities are to be provided:

- indicator showing whether the system is in operation
- optical/audible fault indication
- inclination angle indicator

**G.2** The control console shall be provided with a manual emergency OFF switch for ships which are operated only under supervision.

**G.3** Systems which are also operated without supervision shall be provided with a manual emergency OFF switch and an automatic stop device which shuts down the system independently of the control when the maximum permitted angle of inclination is reached.

**G.4** Automatic stop devices and control units for heel compensation systems are subject to mandatory type approval.

**G.5** In case of danger for persons by working with stabilizers, a local emergency Stop device shall be installed.

## **H Cross-flooding Arrangements**

**H.1** Where closing devices are installed in cross-flooding arrangements, they shall be capable to be operated from the bridge or from a central location (see also the GL Rules for [Machinery Installations \(I-1-2\)](#), [Section 11, P.3.1](#)).

Passenger vessels see [Section 14, C.2.6](#).

**H.2** Controls shall be protected against unintentional use.

**H.3** The position of each closing device shall be indicated on the bridge and at the central operating location.

**H.4** Control and indication of the closing devices shall be realized without computer technique.

## Section 8 Medium-Voltage Installations

A	Scope .....	8-1
B	General Provisions.....	8-1
C	Network Design and Protection Equipment.....	8-4
D	Electrical Equipment .....	8-6
E	Installation .....	8-11

### A Scope

These rules also apply to three-phase networks with rated (phase-to-phase) voltages of > 1 kV and not greater than 17.5 kV, and rated frequencies of 50 Hz or 60 Hz.

### B General Provisions

#### B.1 Reference to other regulations

The general provisions of the GL Rules for Electrical Installations (I-1-3) also apply, as and where appropriate, to medium-voltage installations, except where more particular requirements are laid down in this Section.

#### B.2 Rated mains voltage

The values indicated in [Table 8.1](#) are recommended as standard rated voltages and frequencies.

**Table 8.1 Rated voltages and rated frequencies**

Rated voltage [kV]	Highest voltage for equipment [kV]	Rated frequency [Hz]
3.0 3.3	3.6	50 60
6.0 6.6	7.2	50 60
10.0 11.0	12.0	50 60
15.0 16.5	17.5	50 60

#### B.3 Clearances and creepage distances

##### B.3.1 Clearances

Clearances (phase-to-phase and phase-to-hull) for switchgear shall not be smaller than indicated in [Table 8.2](#).

Intermediate values for rated voltage can be allowed, provided that the next higher minimum clearance is adopted.

**Table 8.2 Minimum clearances for switchgears**

Highest voltage for equipment [kV]	Minimum clearance [mm]
3.6	55
7.2	90
12.0	120
17.5	160

### **B.3.2 Creepage distances**

Creepage distances between live parts, and between live and earthed parts, shall be designed in accordance with the rated voltage of the system, allowance being made for the type of the insulating material and for transient overvoltages due to switching operations and faults.

**B.3.2.1** In the busbar area, creepage distances shall not be less than 25 mm/kV for non-standardized components. The highest voltage for equipment according to IEC publication 60071-1 shall be used as a basis for the dimensioning.

**B.3.2.2** Insulators shall conform to IEC publication 60168 and 60273.

**B.3.2.3** The creepage distances at busbar penetrations shall be in compliance with IEC publication 60137.

**B.3.2.4** The minimum creepage distance behind current limiting circuit breakers and fuses shall not be less than 16 mm/kV.

### **B.4 Degrees of protection**

The degrees of protection specified in [Table 8.3](#) are to be complied with, in addition to the provisions of [Section 1, Table 1.9](#).

**B.4.1** If the required degree of protection is not fulfilled by the equipment itself, adequate protection shall be ensured through appropriate structural measures.

### **B.4.2 Protective measures**

**B.4.2.1** A hazard to persons through electrical shock and accidental arcs shall be avoided independently of the required protection against foreign bodies and water.

**Table 8.3 Minimum degrees of protection against foreign bodies and water (as per IEC 60529)**

Equipment Location	Switchboards	Electrical machinery		Power transformers
		Motors, generators	Terminal boxes	
Locked electrical operational compartments <sup>1</sup>	IP32	IP23	IP44	IP23
Generally accessible operational compartments (category A machinery spaces) and zones below deck (e.g. passage ways, thruster rooms)	IP44	IP44	IP44	IP44
Open deck	–	IP56	IP56	–

<sup>1</sup> Accessible only to trained specialist personnel. Subject to implementation of appropriate safety measures, lower degrees of protection are possible by agreement with GL (see [Section 2, F.1](#) and [G.1](#)).

**B.4.2.2** For switchgear installations it shall be proved that an internal arc test according to IEC publication 62271-200 Annex A had been passed. The criteria 1 to 5 shall be fulfilled, see also [Section 2, G.1.4](#).

**B.4.2.3** Terminal boxes shall be equipped with a device for the calculated expansion of the accidental arc gases. Evidence shall be given to prove the effectiveness of the chosen design.

## **B.5 Equipotential bonding**

**B.5.1** All conductive, but in normal operation dead, components of a medium-voltage installation or equipment shall be provided with an electrically conductive connection to the hull.

**B.5.2** All metal components in the electrical operational compartments shall be included in the equipotential bonding.

## **B.6 Earthing**

**B.6.1** Metal parts shall be earthed if, in the event of a fault, there is a possibility to get in contact with live parts either by direct contact or arcing.

Attention shall be paid to adequate dimensioning of the earthing conductors (e.g. for copper conductors the current density shall not exceed a value of 150 A/mm<sup>2</sup> in the event of a fault).

Such earthing conductors shall have a minimum cross section of 16 mm<sup>2</sup>.

**B.6.2** Metal components that have permanent and electrically conductive connections to the hull need not to be separately earthed. Bolted connections for the fixing of units or components are not considered electrically conductive connections.

## **B.7 Selectivity**

For essential systems, selectivity is to be ensured independently of the neutral point design.

Evidence shall be given to prove down stream selectivity of the complete grid (Low – and medium voltage) under all operating conditions.

This applies to short circuit, over current, and earthfault tripping. Other protection equipment, also those not required by GL, may not interfere with this selectivity concept.

### **B.8 Isolating and earthing devices**

A sufficient number of isolating links and earthing and short-circuit devices shall be provided to enable maintenance work to be performed safely on plant sections.

### **B.9 Control of generator- and bus tie circuit breakers**

A single-fault event in the synchronization circuit or in the black-out monitoring shall not lead to an asynchronous connection.

## **C Network Design and Protection Equipment**

### **C.1 Electrical power supply systems**

**C.1.1** Essentially, the following arrangements are permitted:

- 3 conductors, insulated from the hull
- 3 conductors with earthed star point

#### **Notes**

*Tankers are subject to SOLAS, Chapter II-1, Regulation 5.4.1:*

*Earthed distribution systems shall not be used in tankers. Exceptionally, the direct earthing of the neutral may be approved for three-phase power networks with (phase-to-phase) voltages of 3000 V and over on a tanker, provided that the value of the neutral point impedance limits the earth-fault current to three times the capacitive phase-charging current of the network. If the phase-charging current is capable of exceeding 10 A, automatic trips are to be provided, which isolate the faulty circuit.*

**C.1.2** Medium-voltage systems are permitted only for fixed installed electrical equipment.

### **C.2 Systems with earthed star point**

**C.2.1** The neutral point connection shall incorporate a resistance or other current-limiting device, so that in case of a fault the earth-fault current is limited to the full-load current of the largest generator connected to the switchboard. However, the earth-fault current shall not be less than three times the minimum threshold current of the earth-fault monitor.

**C.2.2** In order to fulfil the selectivity requirement of [B.7](#), measures shall be taken for installations with current-limited neutral earths to ensure selective disconnection of outputs in which an earth fault has occurred.

**C.2.2.1** Electrical equipment shall be designed to withstand a single pole short-circuit current up to the activation of the protective device.

**C.2.3** Highly resistive earthed mains, which outputs will not be isolated in case of an earth fault, are permitted, if the insulation of the equipment is designed according to [C.3.2](#).

**C.2.4** Directly earthed mains without current-limiting device require the prior approval of GL.

### **C.2.5 Isolating links in the neutral point earthing**

For each neutral point, isolating links are to be provided for the purposes of maintenance and measurement.



### **C.2.6 Design of the neutral point connection**

#### **C.2.6.1** All earth resistors shall be connected to the hull.

To prevent possible interference on electronic systems, it is recommended that the individual earth resistors should be conductively linked by cables on the earth side.

#### **C.2.6.2** Generators for parallel operation may have a common hull connection for the neutral point.

For each dividable busbar section directly supplied by generators, a separate neutral point connection shall be provided.

#### **C.2.6.3** Earthing resistors shall be dimensioned for twice of the tripping time and shall be protected against overload and short circuit.

Short circuit protection is sufficient if the earthing resistor is dimensioned for continuous duty.

### **C.3 Systems with isolated neutral point**

**C.3.1** Since intermittent earth-faults can cause transient overvoltages in networks with an isolated neutral, endangered equipment shall be fitted with overvoltage protection. For this overvoltages of at least 3.3 times  $U_N$  shall be considered.

**C.3.2** All insulation (of cables, consumers, transformers, generators, etc.) shall be designed for the phase-to-phase voltage, if earth-faults will not be isolated immediately.

### **C.4 Protection equipment**

The provisions of [Sections 4](#) and [5](#) shall apply, as and where appropriate, to the selection of protection equipment.

#### **C.4.1 Faults on the generator side of the circuit-breaker**

Protective devices shall be provided for phase-to-phase faults in the generator connection line and inter-turn faults within the generator. The protective device (differential protection) shall trip the generator circuit breaker and de-excite the generator.

#### **C.4.2 Earth-fault monitoring**

Every earth-fault in the system shall be visually and audibly signalled.

#### **C.4.3 Power transformers**

**C.4.3.1** The protective devices of power transformers are subject to the provisions of [Section 4, D](#).

**C.4.3.2** Ship service transformers and transformers supplying the power section of a main propulsion drive shall be fitted with differential protection.

**C.4.3.3** Transformers used for supplying primary essential consumers shall be fitted with winding temperature monitors.

**C.4.3.4** Liquid-cooled transformers shall be fitted with protection against outgassing of the liquid.

**C.4.3.5** The liquid temperature shall be monitored. An alarm shall be actuated before the maximum permissible temperature is attained. When the limit temperature is reached, the transformer shall be disconnected.

**C.4.3.6** The liquid filling level shall be monitored by means of two separate sensors. The monitoring system shall actuate an alarm at the first stage and then cause disconnection at the second, when the filling level falls below the permissible limit.

#### **C.4.4 Voltage transformers for control and measuring purposes**

**C.4.4.1** Voltage transformers shall be protected on the secondary side against short-circuit and overload.

#### **C.4.5 HVHRC Fuses**

The use of HVHRC fuses for overload protection is not permitted. They shall be used for short-circuit protection only.

#### **C.4.6 Low-voltage networks**

Low-voltage networks fed via transformers from a medium-voltage network are to be protected against the overvoltages which may result from an insulation failure between the primary and secondary windings.

## **D Electrical Equipment**

### **D.1 General**

#### **D.1.1 Standstill heating**

All electrical equipment which may occasionally be taken out of service and which are not located in heated and ventilated areas shall be equipped with a standstill heater. This heater should switch on automatically when the equipment is switched off.

#### **D.1.2 Installation**

See [Section 2, G](#)

### **D.2 Switchgear**

#### **D.2.1 Construction**

Switchgear accessible for authorized persons only shall at least comply with accessibility type "A" of IEC publication 62271-200.

In public accessible spaces switchgear of accessibility type "B" shall be used. Besides this measures against unauthorised operation shall be provided.

**D.2.1.1** Medium-voltage switchboards shall have metal clad enclosures which are fully partitioned and closed on all sides.

Switchgear supplying secondary essential or non-essential equipment may be of metal enclosed type.

Incorporated low-voltage compartments for control and monitoring systems shall be separated from the medium-voltage compartments in such a way as to render impossible any contact with parts having a rated supply voltage of more than 1000 V.

#### **D.2.1.2 Fully partitioned switchboards**

All sections of a fully partitioned, air-insulated medium-voltage switchboard shall be partitioned with respect to each other and the surroundings so that they are arc-resistant. Continuous busbar compartments or switch compartments are inadmissible.

Each panel shall be subdivided into at least three arc resistant, partitioned function compartments: the terminal compartment, the switch compartment and the busbar compartment.

#### **D.2.1.3 Partly partitioned switchboards**

If the main medium-voltage switchboard is subdivided into two independent and autonomous installations, a continuous busbar compartment is permissible, provided that a protection system (arc monitor, busbar differential protection) is installed which detects internal faults and isolates the affected part of the installation within 100 ms, respectively accidental arcing is reliably prevented by design measures (e.g. solid insulated busbar systems).

**D.2.1.4** Switchboards supplying primary essential consumers shall have the service continuity LSC 2 according to IEC publication 62271-200.

**D.2.1.5** Evidence shall be provided that medium-voltage switchboards have passed a type test according to IEC publication 62271-200. A modification of the construction of a switchboard requires re-testing. The same applies to modifications of the gas exhausting system.

**D.2.1.6** Where drawout switchgear units are used, the following conditions shall be met:

- Functional testing and maintenance shall be capable of being performed in safety, even when the busbar is live.
- Drawout switchgear units shall be fitted with mechanical interlocking devices effective in the operating and disconnected position. A key interlock is permitted for maintenance purposes.

Drawout switchgear units are to be locked in place in the operating position.

- The fixed contacts for drawout switchgear units are to be so arranged that, in the withdrawn position, the live contact components are automatically covered, or that complete withdrawal is possible only after a cover has been fitted.

**D.2.1.7** Doors which give access to medium voltage are to be interlocked in such a way that they can be opened only after closing the earthing switch.

**D.2.1.8** It shall be possible to split main medium-voltage switchboards into two sections by means of at least one circuit breaker. This breaker shall be fitted with selective protection. It shall be possible to supply each section from at least one generator.

Duplicated consumers shall be divided up amongst the dividable switchboard sections.

#### **Note**

*It is recommended that two different, spatially separated main switchboards, coupled via a transfer line, are used.*

**D.2.1.9** The partitioning of a gas insulated switch-board supplying primary essential equipment shall correspond with the requirements of an air insulated switchboard. Each gas volume shall be monitored.

A pressure drop shall be alarmed. Measures according to manufacturer's instruction shall be initiated.

## **D.2.2 Auxiliary systems**

**D.2.2.1** Where electrical energy and/or mechanical energy is required for the operation of switches, a means of storing such energy which is designed for at least two ON/OFF switching cycles of all the connected components shall be provided.

In general tripping due to overload, short circuit or undervoltage shall be independent of any stored electrical energy.

If shunt trip coils are used, the continuity of the tripping circuit has to be monitored. When the wire breakage alarm is activated the switching on shall be interlocked. The power supply has to be monitored.

### **D.2.2.2 Number of energy sources**

For the supply of auxiliary circuits two independent uninterruptible power supplies shall be provided. If one of these uninterruptible power supplies fails, the remaining unit shall supply all switchboard sections. The switch-over to the reserve source of energy shall be automatically and actuate an alarm. One uninterruptible power supply shall be fed from the emergency switchboard, and the other one from the main switchboard.

## **D.2.3 Tests**

A routine test in accordance with IEC publication 62271-200 shall be performed in the manufacturer's works in the presence of a GL surveyor.

A functional test of the interlocking conditions, protective functions, synchronization in the various operating modes shall be performed.

A test schedule shall be compiled and submitted for approval.

**D.2.3.1** It is recommended that a partial-discharge test be performed in accordance with IEC publication 62271-200 Annex B if organic insulating materials or gas-insulated busbar penetrations are used.

### D.2.3.2 High-voltage test

A voltage test at power-frequency shall be performed on every switchgear unit.

The value of the alternating withstand voltage shall be selected in accordance with [Table 8.4](#). The duration of the test is 1 minute in each case.

The following tests shall be carried out in every case:

- conductor to earth
- between conductors

For this purpose, each conductor of the main circuit is connected successively to the high-voltage connection of the test unit. All other conductors of the main and auxiliary circuits are to be earthed.

**Table 8.4 Test voltages for switchgear**

Rated voltage [kV]	Test voltage (rms value) AC withstand voltage [kV]	Impulse test voltage [kV]
1 - 3.6	10	40
3.6 - 7.2	20	60
7.2 - 12	28	75
12 - 17.5	38	95

The dielectrical tests are to be performed with all switching devices in the closed position, and with all withdrawable parts in the operating position.

Voltage transformers or fuses may be replaced by dummies which simulate the electric field distribution of the high-voltage arrangement.

Overvoltage protection devices may be isolated or removed.

### D.2.3.3 Impulse voltage test

An impulse voltage test in accordance with [Table 8.4](#) may be recognized as equivalent to the high-voltage test. The duration of the test comprises 15 successive pulses.

## D.2.4 Low voltage main switchgear design

**D.2.4.1** If the low-voltage main switchboard is supplied from the medium-voltage system a circuit breaker for the longitudinal separation of the main busbar shall be provided.

The bus bar sections shall be supplied by circuit breakers suitable for isolation.

**D.2.4.2** The arrangement of supply- and consumer sections shall be in accordance with [Section 5, C.2](#).

**D.2.4.3** The feeder panels of the low-voltage switchboard shall be partitioned with arc-resistant segregations.

**D.2.4.4** The unsynchronized connection of subnetworks and the feedback on the medium-voltage side shall be prevented by means of interlocking.

**D.2.4.5** Parallel operation of ship service transformers is only permissible for short-term load transfer, if also the medium voltage sides of the transformers are connected.

A forced splitting, independent of the automation system shall be provided.

**D.2.4.6** After black out of the supply of the main switchboard or a partial black out of bus bar sections in the low voltage main switchgear, the recovery of the power supply shall be performed automatically.

**D.2.4.7** If the black out of the supply is caused by a short circuit in the low voltage switchboard no automatic recovery shall be carried out.

**D.2.4.8** The manual connecting of the stand by supply shall be possible after the acknowledgement of short circuit trip.

**D.2.4.9** A stand by alarm shall be triggered, if components, necessary for the automatic recovery, are not available.

**D.2.4.10** A switching off of the medium voltage circuit breaker shall cause the opening of the low voltage circuit breaker.

**D.2.4.11** The supply panels shall meet the requirements for generator panels of this Chapter analogously.

**D.2.4.12** The low voltage supply panels shall be equipped with a voltmeter and an ampere-meter. It shall be possible to display the currents and voltages of all three phases.

**D.2.4.13** The operation modes On, Off, Tripped and Ready shall be indicated by signal lights.

### **D.3 Switchboard equipment**

#### **D.3.1 General**

Control circuit equipment is subject to the conditions for low-voltage switchgear (see [Section 5](#)).

#### **D.3.2 Circuit breakers**

It shall be possible to operate the mechanical off of the circuit breaker having the doors closed.

It is to prove that the circuit breaker fulfils the requirements of [Section 20](#), [E.3.1.1 d](#)) also when actuating the mechanical on button.

Circuit breakers shall comply with IEC publication 62271-100.

**D.3.2.1** For drawout circuit breakers, see [D.2.1.5](#).

**D.3.2.2** Circuit breakers shall be interlocked with the associated earthing switch.

#### **D.3.3 Load switch-disconnectors and isolating switches**

Load switch-disconnectors and isolating switches shall comply with IEC publication 62271-102/103.

**D.3.3.1** Isolating switches shall be interlocked so that they can only be switched under no load. The use of load-switch-disconnectors is recommended.

**D.3.3.2** Earthing switches shall have making capacity.

#### **D.3.4 HVHRC fuses**

HVHRC fuses shall conform to IEC publication 60282.

#### **D.3.5 Power contactors**

Power contactors shall conform to IEC publication 62271-106.

Medium voltage power contactor fuse combinations shall be dimensioned according to IEC publication 62271-106 subclause 4.107.3 damage classification „type c“.

Is the safety of the staff and the selective protection of the ships grid ensured by connected upstream devices medium voltage contactors supplying secondary or unessential consumers may be dimensioned according to “damage classification type a” of IEC publication 62271-106.

#### **D.3.6 Current- and voltage transformers**

**D.3.6.1** Transformers shall conform to the following IEC publications:

- current transformers, IEC publication 60044-1
- voltage transformers, IEC publication 60044-2

#### **D.3.6.2 Earthing of current- and voltage transformers**

The secondary winding of every current- and voltage transformer shall be earthed by means of a copper conductor at least 4 mm<sup>2</sup> in cross-section.

Open delta windings shall only be earthed at one point.

#### **D.3.7 Relays**

Relays for measuring and protective devices shall conform to IEC publication 60255.

### **D.4 Electrical machines**

#### **D.4.1 Design**

##### **D.4.1.1 Generator stator windings**

The ends of all stator windings shall be run to terminals in the terminal box.

##### **D.4.1.2 Winding temperature monitoring**

The stator windings of electrical machines shall be equipped with temperature detectors. Inadmissible temperature rises shall actuate visual and audible alarms. Measures are to be taken which protect the measuring circuit against overvoltages.

##### **D.4.2 Terminal boxes**

Terminals with operating voltages above 1000 V shall be provided with their own terminal boxes. Terminals shall be marked clearly, see also [B.4.2.3](#).

##### **D.4.3 Tests**

The tests specified in [Section 20, A](#) apply to medium-voltage machines, as and where appropriate.

### **D.5 Power transformers**

#### **D.5.1 Design**

**D.5.1.1** Power transformers shall conform to IEC publication 60076.

**D.5.1.2** Dry-type transformers should be used by preference. They shall conform to IEC publication 60726. Exceptions shall be agreed with GL.

**D.5.1.3** Only transformers with separate windings shall be used. Exceptions are auto-transformer starters.

**D.5.1.4** Transformers producing a low voltage from a medium voltage shall be equipped with an earthed shielding winding between the low-voltage and medium-voltage coil.

**D.5.1.5** If liquid-cooled transformers are used, measures shall be taken to ensure that the windings are completely covered by oil, even for inclinations of 22.5°.

#### **D.5.2 Ship service transformers**

**D.5.2.1** If the ship's low-voltage network is supplied from the medium-voltage network, at least two mutual independent ship service transformers shall be installed.

Control and protection shall comply correspondingly with the requirements of [Section 4](#) and [5](#) for the main electrical power supply.

**D.5.2.2** Ship service transformers shall be equipped with an amperemeter. It shall be possible to display the current of all three phases.

### **D.5.3 Tests**

Power transformers shall be individually tested at the manufacturer's works in the presence of a GL Surveyor.

**D.5.3.1** The scope of the tests is specified in [Section 20, B](#) and in the relevant IEC standards

**D.5.3.2** The test voltages shall be selected in accordance with [Section 20, Table 20.7](#).

### **D.6 High Voltage Shore Connection (HVSC) Systems**

**D.6.1** For High Voltage Shore Connection (HVSC) Systems the requirements set forth in the IEC Publication 80005-1 Utility connections in Port- Part 1: High Voltage Shore Connection (HVSC) Systems - General requirements are applicable.

**D.6.2** The plugging and unplugging of the high voltage plug connection shall be possible only when both sides are isolated and earthed.

**D.6.3** The safety of the personnel while connecting, operating and disconnecting of the HV connections shall be warranted by the construction, choice of components and their place of installation along with a proper interlocking system.

**D.6.4** A failure in the shore power supply equipment while under sea- or manoeuvre condition must not impair the availability of the main source of electrical power. For components installed outside the compartment of the main source of electrical power hazards by fire and water shall be considered.

### **D.7 Cables**

#### **D.7.1 General**

**D.7.1.1** Medium-voltage cables shall conform to IEC publication 60092-354 or 60502.

**D.7.1.2** Medium-voltage cables shall be marked.

**D.7.1.3** The regulations stated in [Section 12](#) apply as and where appropriate.

#### **D.7.2 Selection of cables**

**D.7.2.1** The nominal voltage of a cable shall not be less than the nominal operational voltage of the related circuit.

**D.7.2.2** In insulated-neutral networks, the phase-to-phase voltage (U) of the network shall be deemed to be the rated voltage (U<sub>0</sub>) of the cable between one conductor and the ship's hull, see also [C.3.2](#).

#### **D.7.3 Tests**

Tests shall be performed in accordance with [Section 20, F](#), as and where appropriate.

The voltages for the high-voltage test are listed in [Table 8.5](#).

## **E Installation**

### **E.1 General**

See [Section 2, G](#)

## **E.2 Cable installation**

### **E.2.1 Cable routes**

In accommodation spaces, high voltage cables are to be run in enclosed metallic cable conduits. In the case of cable layouts not adhering to this Rule, approval by GL is required prior to the start of installation work.

### **E.2.2 Separation of cables**

**E.2.2.1** Medium voltage cables operating at different voltages are to be segregated from each other; in particular, they are not to be run in the same cable bunch, nor in the same ducts or pipes, or, in the same box. Where medium voltage cables of different voltage ratings are installed on the same cable tray, the air clearance between cables is not to be less than the minimum air clearance for the higher voltage side shown in [Table 8.2](#).

**E.2.2.2** Medium voltage cables are not to be installed on the same cable tray for the cables operating at the nominal system voltage of 1 kV and less.

Other means of separation are to be agreed by GL.

### **E.2.3 Construction of the installation**

**E.2.3.1** Medium-voltage cables laid in open cable trays shall be provided with continuous metal shields and armourings against mechanical damage; shields and armourings shall be electrically conductive connected to the ship's hull.

**E.2.3.2** Medium-voltage cables without armouring shall be laid so that they are protected against mechanical damages, e.g. in closed metal ducts which are electrically conductive connected to the ship's hull.

For the installation of single core cables the metal ducts shall be made of non magnetic material, unless the cables are installed in triangle formation.

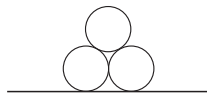

**E.2.3.3** For bends, the minimum-bending radius permitted by the manufacturer shall be observed; if not specified than the bending radius shall be not smaller than 12 times of the outer diameters of the cable.

### **E.2.4 Marking of cable ducts and conduits**

Cable ducts and conduits for medium-voltage cables shall be marked in accordance with [Section 2, G](#).

### **E.2.5 Connections**

**E.2.5.1** As far as is feasible, all connections of a medium-voltage cable shall be covered with suitable insulating materials.

**E.2.5.2** In terminal boxes where the conductors are not insulated, the phases are to be separated from each other and from the hull potential by mechanically robust barriers of suitable insulating material.

### **E.2.6 Sealing ends, joints and kits**

**E.2.6.1** For medium-voltage kits from 3.6/6 kV measures shall be taken to attenuate the electrical fields which occur at points where cable insulations are removed (sealing ends).

**E.2.6.2** The materials of sealing ends and joints shall be compatible to the corresponding cables.

**E.2.6.3** The construction of joints shall permit the separate through-connection of all shields and armourings.

**E.2.6.4** Sealing ends shall enable shields and armourings to be brought out.



### E.2.7 Processing

The manufacturer's assembly instructions shall be observed.

### E.3 Tests

#### E.3.1 Tests following installation

When the installation work has been completed, medium-voltage cables are to undergo voltage tests in the presence of a GL Surveyor; the sealing ends and cable joints shall also be tested.

The test is to conform to IEC publication 60502.

#### Note

*Compliance with the safety regulations for tests at high voltage is the responsibility of the person in charge.*

**E.3.2** The following tests can be applied alternatively:

- high-voltage test at 70 % of the DC voltage test value shown in [Table 8.5](#) for a period of 15 minutes between conductor and shield, or
- test using the rated (phase-to-phase) voltage/ frequency between conductor and shield for a period of 5 minutes, or
- test using the operating voltage of the system for a period of 24 hours

**E.3.3** The insulation resistance is to be measured before and after the high-voltage test (500 V/ 200 MΩ).

**Table 8.5 Test voltages for medium-voltage cables**

Max. system voltage $U_m$	kV	1.2	3.6	7.2	12	17.5	24.0
Rated voltage $U_o/U$	kV/kV	0.6/1.0	1.8/3.0	3.6/6.0	6.0/10.0	8.7/15.0	12.0/20.0
AC test voltage	kV	3.5	6.5	11.0	15.0	22.0	30.0
DC test voltage	kV	8.4	15.6	26.4	36.0	52.8	72.0

#### Notes

$U_o$  : rated voltage between conductor and earth or metal shield.

$U$  : rated voltage between the conductors for which the cable is designed.



## Section 9 Control, Monitoring and Ship's Safety Systems

A	General Requirements.....	9-1
B	Machinery Control and Monitoring Installations.....	9-2
C	Ship Control Systems .....	9-6
D	Ship Safety Systems.....	9-9

### A General Requirements

#### A.1 Scope

**A.1.1** This Section sets out requirements for the equipment and design of control, monitoring and ship's safety systems necessary for the operation of the ship and the machinery installation and for the safety of the vessel.

**A.1.2** The general requirements stated in this Section also apply to the open and closed-loop control and measuring systems of essential equipment, see [Section 1](#).

**A.1.3** Regarding additional requirements for ships with unmanned engine room see the GL Rules for [Automation \(I-1-4\)](#).

#### A.2 Planning and design

**A.2.1** The requirements laid down for each unit and system depend on their use and the process-technological conditions. The Construction Rules stipulate the minimum requirements for these.

**A.2.2** If special operating conditions call for a particular system design, GL reserve the right to impose additional requirements, depending on the operational and system-specific considerations.

**A.2.3** The design of safety measures, open and closed loop controls and monitoring of equipment shall limit any potential risk in the event of breakdown or defect to a justifiable level of residual risk.

**A.2.4** Where appropriate, the following basic requirements shall be observed:

- compatibility with the environmental and operating conditions
- compliance with accuracy requirements
- recognizability and constancy of the parameter settings, limiting- and actual values
- compatibility of the measuring, open and closed loop controls and monitoring systems with the process and its special requirements
- immunity of system elements to reactive effects in overall system operation
- non-critical behaviour in the event of power failure, restoration and of faults
- unambiguous operation
- maintainability, the ability to recognise faults and test capability
- reproducibility of values

**A.2.5** Automatic interventions shall be provided where damage cannot be avoided by manual intervention.

**A.2.6** If dangers to persons or the safety of the ship arising from normal operation or from faults or malfunctions in machinery or plant, or in control, monitoring and measuring systems, cannot be ruled out, safety devices or safety measures are required.

**A.2.7** If dangers to machinery and systems arising from faults or malfunctions in control, monitoring and measuring systems cannot be ruled out, protective devices or protective measures are required.

**A.2.8** Where mechanical systems or equipment are either completely or partly replaced by electric/electronic equipment, the requirements relating to mechanical systems and equipment according to the GL Rules for [Machinery Installations \(I-1-2\)](#) shall be met accordingly.

### **A.3 Design and construction**

**A.3.1** Machinery alarm systems, protection and safety systems, together with open and closed loop control systems for essential equipment shall be constructed in such a way that faults and malfunctions affect only the directly involved function. This also applies to measuring facilities.

**A.3.2** For machinery and systems which are controlled remotely or automatically, control and monitoring facilities shall be provided to permit manual operation.

**A.3.3** In the event of disturbances automatically switched-off plants shall not be released for restarting until having been manually unlocked.

### **A.4 Application of computer systems**

If computer systems are used, [Section 10](#) has to be observed.

### **A.5 Maintenance**

**A.5.1** Access shall be provided to systems to allow measurements and repairs to be carried out. Facilities such as simulation circuits, test jacks, pilot lamps, etc. are to be provided to allow functional checks to be carried out and faults to be located.

**A.5.2** The operational capability of other systems shall not be impaired as a result of maintenance procedures.

**A.5.3** Where the replacement of circuit boards in equipment which is switched on may result in the failure of components or in the critical condition of systems, a warning sign shall be fitted to indicate the risk.

**A.5.4** Circuit boards and plug-in connections shall be protected against unintentional mixing up. Alternatively they shall be clearly marked to show where they belong to.

## **B Machinery Control and Monitoring Installations**

### **B.1 Safety devices**

**B.1.1** The design of safety devices shall be as simple as possible and shall be reliable and inevitable in operation. Proven safety devices which are not depending on a power source are to be preferred.

**B.1.2** The suitability and function of safety devices shall be demonstrated in the given application.

**B.1.3** Safety devices shall be designed so that potential faults such as, for example, loss of voltage or a broken wire shall not create a hazard to human life, ship or machinery.

These faults and also the tripping of safety devices shall be signalled by an alarm.

**B.1.4** For preference, safety devices shall be designed in conventional technology (hard wired). Alternative technical solutions shall be agreed with GL.

**B.1.5** The adjustment facilities for safety devices shall be designed so that the last setting can be detected.

**B.1.6** Where auxiliary energy is needed for the function of safety devices, this has to be monitored and a failure has to be alarmed.

**B.1.7** Security equipment like short circuit monitoring of generators as well as overspeed monitoring of diesel engines shall run independently from automatic power control system, to ensure that the equipment can continue operating manually in case of a breakdown.

**B.1.8** Safety devices are subject to mandatory type approval.

## **B.2 Safety systems**

**B.2.1** Safety systems shall be independent of open and closed loop control and alarm systems. Faults in one system shall not affect other systems.

Deviations from this requirement may be allowed for redundant equipment with the agreement of GL where this would entail no risk to human life and where ship safety would not be compromised.

**B.2.2** Safety systems shall be assigned to systems which need protection.

**B.2.3** Where safety systems are provided with overriding arrangements, these shall be protected against unintentional operation. The actuation of overriding arrangements shall be indicated and recorded.

**B.2.4** The monitored open-circuit principle shall be used for safety systems. Alternatively, the closed circuit principle shall be applied where the provisions of national regulations demand it. (e.g. boiler and oil-fired systems). Equivalent monitoring principles are permitted.

Faults, and also the tripping of safety systems shall be indicated by an alarm and recorded.

**B.2.5** Safety systems shall be designed for preference using conventional technology (hard wired). Alternative technical solutions shall be agreed with GL.

**B.2.6** The power supply shall be monitored and loss of power shall be indicated by an alarm and recorded.

**B.2.7** Safety systems are subject to mandatory type approval.

## **B.3 Open loop control**

**B.3.1** Main engines and essential equipment shall be provided with effective means for the control of its operation. All controls for essential equipment shall be independent or so designed that failure of one system does not impair the performance of other systems, see also [A.2.4](#), [B.8](#) and [B.9](#).

**B.3.2** Control equipment shall have built-in protection features where incorrect operation would result in serious damage or in the loss of essential functions.

**B.3.3** The consequences of control commands shall be indicated at the respective control station.

**B.3.4** Controls shall correspond with regard to their position and direction of operation to the system being controlled resp. to the direction of motion of the ship.

**B.3.5** It shall be possible to control the essential equipment at or near to the equipment concerned.

**B.3.6** Where controls are possible from several control stations, the following shall be observed:

- Competitive commands shall be prevented by suitable interlocks. The control station in operation shall be recognizable as such.
- Taking over of command shall only be possible with the authorization of the user of the control station which is in operation.
- Precautions shall be taken to prevent changes to desired values due to a change-over in control station.
- Open loop control for speed and power of internal combustion engines (main and auxiliary engines) and electrical actuators are subject to mandatory type approval.

#### **B.4 Closed loop control**

**B.4.1** Closed loop control shall keep the process variables under normal conditions within the specified limits.

**B.4.2** Closed loop controls shall maintain the specified reaction over the full control range. Anticipated variations of the parameters shall be considered during the planning.

**B.4.3** Defects in a control loop shall not impair the function of operationally essential control loops.

**B.4.4** The power supply of operationally essential control loops shall be monitored and power failure shall be signalled by an alarm.

**B.4.5** Closed loop control for speed and power of internal combustion engines (main and auxiliary engines) and electrical actuators are subject to mandatory type testing.

#### **B.5 Alarm systems**

**B.5.1** Alarm systems shall indicate unacceptable deviations from operating figures optically and audibly.

**B.5.2** Alarm delays shall be kept within such time limits that any risk to the monitored system is prevented if the limit value is exceeded.

**B.5.3** Optical signals shall be individually indicated. The meaning of the individual indications shall be clearly identifiable by text or symbols.

If a fault is indicated, the optical signal shall remain visible until the fault has been eliminated. It shall be possible to distinguish between an optical signal which has been acknowledged and one that has not been acknowledged.

**B.5.4** It shall be possible to acknowledge audible signals.

The acknowledgement of an alarm shall not inhibit an alarm which has been generated by new causes.

Alarms shall be discernible under all operating conditions. Where this cannot be achieved, for example due to the noise level, additional optical signals, e.g. flashing lights shall be installed.

**B.5.5** In individual cases, GL may approve collective alarms from essential, stand-alone systems which are signalled to the machinery alarm system.

**B.5.5.1** Each new single alarm, which will not lead to stop, has to retrigger the collective alarm.

**B.5.5.2** The individual alarms have to be recognisable at the concerned system.

**B.5.6** Transient faults which are self-correcting without intervention shall be memorized and indicated by optical signals which shall only disappear when the alarm has been acknowledged.

**B.5.7** Alarm systems shall be designed according to the closed-circuit principle or the monitored open-circuit principle. Equivalent monitoring principles are permitted.

**B.5.8** The power supply shall be monitored and a failure shall cause an alarm.

## **B.6 Operational devices for main- and auxiliary engines**

Operational devices required for the engine room control position in accordance with the GL Rules for [Machinery Installations \(I-1-2\), Section 2, I.2.1 and I.2.2](#) for:

- speed/direction of rotation
- lubricating oil pressure
- control air pressure
- fuel pressure

shall be electrically independent of other systems.

## **B.7 Reversal alarm system**

On ships whose main engines are not remotely controlled from the navigating bridge, the engine telegraph system shall be equipped with a reversal alarm. An audible signal shall sound until the direction of motion demanded by the engine telegraph corresponds with the direction of rotation of the main engine, as indicated by the reversing shaft.

## **B.8 Speed/output controls of diesel engines**

### **B.8.1 General**

**B.8.1.1** The governor and the actuator shall be suitable for controlling the engine under the operating conditions laid down in the Rules for Construction and shall be also in line with the requirements specified by the engine manufacturer, see the GL Rules for [Machinery Installations \(I-1-2\), Section 2, F](#).

**B.8.1.2** Electrical governors and the associated actuators are subject to mandatory type approval.

**B.8.1.3** In the event of faults in the governor system, the operating condition of the engine shall not become dangerous.

Faults in the governor system shall cause an alarm.

In the case of main propulsion engines, engine speed and power shall not increase.

In the case of auxiliary engines, in the event of faults in the governor system, the fuel admission in the injection pumps shall be set to "0".

### **B.8.2 Power supply to the control systems of main propulsion engines**

**B.8.2.1** Control systems with an independent back-up system shall be supplied from the main source of electrical power.

**B.8.2.2** Where main propulsion engines can be operated without a supply of electrical power (pumps driven from the main engine), their control systems (if they have no back-up system) shall be supplied from the main source of electrical power with battery back-up for at least 15 minutes.

The automation battery, if of sufficient capacity, may be used for this purpose.

**B.8.2.3** Where main propulsion engines can only be operated with a supply of electrical power (electrically driven pumps), their control systems shall be fed from the main source of electrical power.

**B.8.2.4** Dedicated power supplies shall be provided for each control system of plants comprising a number of main propulsion engines.

**B.8.2.5** Batteries shall not be discharged by the control system following an engine shutdown.

### **B.8.3 Power supply to the control systems of generator sets**

**B.8.3.1** Each control system shall be provided with a separate supply from the main source of electrical power with battery back-up for at least 15 minutes.

**B.8.3.2** If there are more than two auxiliary engines, a total of two back-up batteries is sufficient.

**B.8.3.3** If the auxiliary engines are started electrically, a combination of the back-up battery with the starter battery is permissible.

The automation battery may be used as a second back-up battery to boost the input voltage.

**B.8.3.4** No supply or battery back-up is required for a control system with its own power source.

**B.8.3.5** No battery back-up is needed if a back-up system is provided.

**B.8.3.6** Batteries shall not be discharged by the control system following an engine shutdown.

## **B.9 Integration of systems for essential equipment**

**B.9.1** The integration of functions of independent equipment shall not decrease the reliability of the single equipment.

**B.9.2** A defect in one of the subsystems (individual module, unit or subsystem) of the integrated system shall not affect the function of other subsystems.

**B.9.3** Any failure in the transfer of data of autonomous subsystems which are linked together shall not impair their independent function.

**B.9.4** Essential equipment shall also be capable of being operated independently of integrated systems.

## **C Ship Control Systems**

### **C.1 Remote control of the main engine**

Where the remote control of the main engine from the bridge is envisaged, the requirements according to the GL Rules for [Automation \(I-1-4\)](#), [Section 5, A](#) shall be observed.

### **C.2 Engine telegraph systems**

#### **C.2.1 General**

**C.2.1.1** Two independent means shall be provided for communicating orders from the navigation bridge to the position in the machinery space or in the control room from which main propulsion is normally controlled.

One of these means shall be an engine telegraph. A further means according to [C.2.3](#) or [C.5.1](#) could be provided.

**C.2.1.2** Engine telegraphs shall be of the two-way systems type in which the signal given by the receiver is also immediately discernible at the transmitter.

**C.2.1.3** In the case of installations with several control positions the acknowledged command shall be indicated at all control positions. Where control positions are selected by switching, additionally indication shall be provided of which one is in use.

**C.2.1.4** Transmitters and receivers shall be equipped with call-up devices which remain activated from the start of the command transmission until it is correctly acknowledged.

**C.2.1.5** The audible signal shall be hearable at all points in the engine room. If necessary, optical signals shall be provided in addition to the audible signals.

**C.2.1.6** Power Supply shall be provided from the main source of electrical power.



## **C.2.2 Main engine telegraph system**

**C.2.2.1** The controls of the transmitters and receivers shall be safeguarded by suitable means (e.g. notching) against inadvertently move.

**C.2.2.2** Engine telegraphs shall be of the two-way systems type in which the signal given by the receiver is also immediately discernible at the transmitter.

**C.2.2.3** In the case of installations with several control positions the acknowledged command shall be indicated at all control positions. Where control positions are selected by switching, additionally indication shall be provided of which one is in use.

**C.2.2.4** Transmitters and receivers shall be equipped with call-up devices which remain in operation from the start of the command transmission until it is correctly acknowledged. The audible signal shall be hearable at all points in the engine room. If necessary, optical signals shall be provided in addition to the audible signals.

**C.2.2.5** Power supply shall be provided from the main source of electrical power.

## **C.2.3 Emergency engine telegraph system**

**C.2.3.1** The function of the emergency engine telegraph system shall conform to that of the main system in accordance with [C.2.2.1](#) and [C.2.2.2](#).

Power supply shall be provided from the emergency source of electrical power.

**C.2.3.2** Instead of the emergency engine telegraph system a further means according to [C.5.1](#) could be provided.

## **C.3 Indicators on the bridge**

**C.3.1** All instruments and indicators important to the control of the ship shall be legible at all times.

**C.3.2** All indicators and illuminations for instruments shall be provided with dimmers.

**C.3.3** All illumination and lighting of instruments shall be adjustable down to zero, except the lighting of warning and alarm indicators and the control of the dimmers which shall remain readable.

**C.3.4** Each instrument shall be fitted with an individual light adjustment. In addition, groups of instruments normally working together may be equipped with common light adjustment.

## **C.4 Rudder angle indicators**

**C.4.1** The ship's main control station shall be equipped with a rudder angle indicator whose transmitter is actuated by the rudderstock.

**C.4.2** All the equipment forming part of the rudder angle indicator system shall be independent of the steering gear control.

**C.4.3** The rudder angle indicator shall be legible from all control stations on the bridge. The display shall be continuous.

**C.4.4** If the rudder angle is not clearly apparent at the emergency manual steering gear control position in the steering gear compartment, an additional rudder angle indicator shall be fitted.

**C.4.5** The above requirements also apply, as and where appropriate, to rudder propeller systems. The indicators shall be so designed that they indicate the thrust direction of motion of the ship.

**C.4.6** If the steering gear shall be also supplied from the emergency source of electrical power, the rudder angle indicator shall be supplied from the main and emergency source of electrical power (see also [Section 7, A.2.3](#)).

## **C.5 Communication, voice communication and signalling systems**

### **C.5.1 Important means of communication**

**C.5.1.1** The means of communication shall be designed to ensure satisfactory intercommunication under all operating conditions.

**C.5.1.2** The means of communication shall be designed as individual links. Alternatively a telephone system or an intercommunication system may be used, provided that the bridge can cut into existing communications in any event.

**C.5.1.3** The call-up devices shall be so designed that they are discernible under the respective environmental conditions. Additional optical means may be used for this purpose.

**C.5.1.4** If the means of communication requires an electrical power supply, this supply shall be from the main switchboard and the emergency switchboard. [Section 3, C.3.2.4](#) and [C.3.4.2](#) are to be observed.

**C.5.1.5** An appropriate mean of communication shall be provided from the navigation bridge and the engine-room to any other position from which the main propulsion plant may be controlled.

**C.5.1.6** An appropriate means of communication shall be provided between the navigation bridge and the steering gear compartment.

### **C.5.2 Voice communications in an emergency**

**C.5.2.1** An intercommunication system shall be provided which enables commands to be transmitted between strategically important locations, the assembly point, the emergency control stations, the muster stations and the launching stations of lifesaving equipment.

**C.5.2.2** This system may comprise portable or permanently installed equipment, and shall also be operable in the event of a failure of the main power supply.

**C.5.2.3** If portable equipment is provided the number of VHF transceivers shall be at least:

- 2 on cargo ships  $\geq 300$  GRT
- 3 on cargo ships  $\geq 500$  GRT

### **C.5.3 Technical officer's alarm (Engineers' call)**

From the engine room or from the engine control room it shall be possible to transmit an alarm into the accommodation area of the technical officers or the crew members responsible for the machinery.

For ships with automated machinery, the GL Rules for [Automation \(I-1-4\)](#), [Section 4](#) is to be observed additionally.

### **C.5.4 CO<sub>2</sub>-alarm systems**

For the general design and construction of CO<sub>2</sub> alarm systems, see the GL Rules for [Machinery Installations \(I-1-2\)](#), [Section 12, G](#) and [H](#).

**C.5.4.1** For machinery spaces, boiler, cargo pump rooms and similar spaces audible alarms of horn or siren sound and optical alarms are to be provided which shall be independent of the discharge of CO<sub>2</sub>. The audible warning is to be automatically actuated a suitable time before flooding occurs and is to be clearly distinguishable from all other alarm signals.

As adequate shall be considered the period of time necessary to evacuate the space to be flooded but not less than 20 s. The system is to be designed such that flooding is not possible before this period of time has elapsed.

The automatic actuation of the CO<sub>2</sub> alarm in the protected space may be realized by e.g. opening the door of the release station.

The emission of audible and optical alarms shall continue as long as the flooding valves are open.

An automatically trip of emergency shutdown facilities by the CO<sub>2</sub>-alarm is not permitted (see also the GL Rules for [Machinery Installations \(I-1-2\)](#), [Section 12, B.10.1](#)).

**C.5.4.2** Where adjoining and interconnecting spaces (e.g. machinery space, purifier room, machinery control room) have separate flooding systems, any danger to persons shall be excluded by suitable alarms in the adjoining spaces.

**C.5.4.3** Audible and optical alarms (pre-discharge alarms as defined in [C.5.4.1](#)) are also to be provided in ro-ro cargo spaces, spaces for the transport of reefer containers and other spaces where personnel can be expected to enter and where the access is therefore facilitated by doors or manway hatches. In conventional cargo spaces and small spaces, e.g. small compressor rooms, paint stores, etc., alarms may be dispensed with on application.

**C.5.4.4** CO<sub>2</sub>-alarm systems shall be supplied from the emergency switchboard.

**C.5.4.5** If the alarm is operated pneumatically, a permanent supply of compressed air for the alarm system is to be ensured.

**C.5.4.6** Alarm systems for the cargo area of tankers see [Section 15](#).

### **C.5.5 Lift alarm**

**C.5.5.1** Lift cabins with internal controls shall be equipped with an audible emergency calling device which can be actuated from the lift cabin. The alarm shall be transferred to a permanently manned location.

**C.5.5.2** A telephone (sound powered, battery operated or electrically powered), or equivalent means of communication, shall be permanently installed in lift cabins with internal controls and connected to a permanently manned location.

**C.5.5.3** The emergency calling system and the telephone shall be supplied from the emergency source of electrical power and shall be independent of the power and control system.

### **C.5.6 Refrigerating hold closure alarm**

A closure alarm shall be provided to a permanently-manned location. The system shall initiate an alarm immediately. Illuminated switches situated near the access doors of each refrigerated space shall be installed.

## **D Ship Safety Systems**

### **D.1 General emergency alarm**

#### **D.1.1 General**

**D.1.1.1** Ships of more than 500 GRT shall be provided with an alarm system to alert the passengers and/or the crew or to call them to the assembly points. It shall be possible to release the alarm from the bridge and, except for the ship's whistle, also from other strategic important locations. The lifeboat station, when also musters station, fire control station and cargo control station shall be considered as strategic points.

**D.1.1.2** Means for announcement shall be provided in a sufficient number to ensure that all persons inside the accommodation and normal crew working spaces are alerted.

#### **Note**

*Regarding the required sound pressure level the IMO LSA Code (Resolution MSC.48/66) shall be observed.*

**D.1.1.3** In noisy rooms, additional optical means of alarm may be required.

**D.1.1.4** Once released, the alarm shall sound continuously until it is switched off manually or is temporarily interrupted for an announcement through the public address system.

**D.1.1.5** Entertainment systems shall be automatically turned off if the general emergency alarm is announced.

**D.1.1.6** Cables for general emergency alarm installations and for loudspeaker systems shall be acc. to [Section 12, D.15](#).

**D.1.1.7** The general emergency alarm shall be powered from the ship's main supply and the emergency source of electrical power.

## **D.2 Public address system (PA system)**

**D.2.1** In addition to the general emergency alarm system, a public address system is required which can be operated from the navigation bridge and at least two other strategic points. The lifeboat station, fire control station and cargo control station shall be considered as strategic points. The public address system shall be audible throughout the accommodation area, at the crew's normal working places and at the strategic important locations.

**D.2.2** If the public address system is used to announce the general emergency alarm, the following requirements shall be fulfilled:

- The requirements for the general emergency alarm shall be fulfilled.
- At least two loudspeaker circuits supplied from separate amplifiers, shall be installed in each fire zone, respectively in its subdivisions.
- The loudspeaker circuits shall be so arranged that an announcement at a reduced acoustic irradiation is maintained in the event of a failure of an amplifier or loudspeaker circuit.
- The system shall be so arranged to minimize the effect of a single failure, by the use of at least 2 amplifiers, segregated supply with fuse protection, segregated cable routes and segregated arrangement.
- Where loudspeakers with built-in volume controls are used, the volume controls shall be disabled by the release of the alarm signal.
- It shall be possible to transmit the undistorted and clearly audible alarm signal at all times. Other simultaneous transmissions shall be automatically interrupted.

**D.2.3** It shall be possible to operate all loudspeakers at the same time.

**D.2.4** The public address system shall be designed under observance of the minimum required sound level.

In a case of emergency the announcements in all areas shall be understandable and above the ambient noise.

Announcement via microphone shall be free of acoustical feedback and other disturbances.

## **D.3 Fire detection and fire alarm systems**

### **D.3.1 General**

See also the GL Rules for [Machinery Installations \(I-1-2\), Section 12](#).

**D.3.1.1** Fire detection and fire alarm systems are subject to mandatory type approval.

**D.3.1.2** The central fire alarm panel shall be located on the bridge or in the main fire control station.

One indicating unit shall be placed on the bridge if the central fire alarm panel is not located there.

An additional indicating unit shall be located in the cargo control room or where the cargo control console is installed (e.g. ship's office, engine control room).

**D.3.1.3** Identifying devices, central fire alarm panel or fire indicator board shall indicate the section in which a fire detector has been activated. At least one indicating unit shall be so located that it is at all times accessible to responsible crew members.

**D.3.1.4** On the fire indicating units or on the central fire alarm panel, clear information shall be provided showing which rooms are monitored, and where the individual sections are located.

**D.3.1.5** The fire detection system shall be self-monitored. Faults, such as a supply failure, short circuit or wire break in detection loops, the removal of a detector from its base and earth fault in detection loops with all-pole insulation shall be optically and audibly signalled at the central fire alarm panel. Fault alarms shall be acknowledgeable and distinguishable from a fire alarm.

**D.3.1.6** Short circuit or disconnection of the signal transfer between the fire detection system and the controller of fire safety systems, fire alarm systems or alarm devices shall be provided.

**D.3.1.7** The emission of audible and optical alarms shall continue until they are acknowledged at the central fire alarm panel. If only a repeater is installed on the bridge, the acknowledgement of the audible alarm on the fire indicating unit shall be independent from the central fire alarm panel. Acknowledgement shall not disconnect the detection loop, nor shall it suppress further alarm signals in other detection loops.

The control panel shall clearly distinguish between normal, alarm, acknowledged alarm, fault and silenced conditions.

**D.3.1.8** The fixed fire detection and fire alarm systems shall be arranged to automatically reset to the normal operating condition after alarm and fault conditions are cleared.

**D.3.1.9** The central station shall be provided with means for testing and disconnecting of individual detectors or detector loops. When a particular detector/detector loop is disconnected, this shall be clearly recognizable.

Means for such recognition shall be provided for each loop.

The failure or disconnection of one detector loop shall not affect the operation of another detector loop.

The simultaneous response of detectors shall not impair the operation of the system.

**D.3.1.10** The fire alarm shall be audible and optical recognized on the fire control panel, on the indicating units and by a responsible engineer officer without any time delay. If a fire alarm is not acknowledged within two minutes, an audible alarm shall be automatically released in all crew accommodation areas, service rooms, control stations and category A machinery spaces. This alarm system need not to be integrated into the fire detection system. The general emergency alarm signalling appliances may be used for this purpose.

**D.3.1.11** Fire detection systems shall not be used for other purposes, except for the automatic closure of fire doors, shut-off fans, closure of fire dampers, sprinkler systems, smoke extraction systems, low-location lighting systems, fixed local application fire-extinguishing systems, CCTV systems, paging systems, fire alarm, public address systems or other fire safety systems.

The fire detection system can be connected to a decision management system. A failure of the data interface shall not impair their independent functions.

Automatic stopping of engine room fans and appropriate flaps is not permitted.

**D.3.1.12** Automatic fire detectors shall respond to heat, smoke or other combustion products, flames or a combination of these factors. Detectors which are activated by other factors may be approved, provided they are not less sensitive than the aforementioned detectors.

**D.3.1.13** Smoke detectors required in all stairways, corridors and escape routes within accommodation spaces shall be certified to operate before the smoke density exceeds 12.5 % obscuration per metre, but not until the smoke density exceeds 2 % obscuration per metre.

**D.3.1.14** Heat detectors shall be actuated at a temperature of between 54 °C and 78 °C when the temperature rises to those limits at a rate of rise less than 1 °C per minute. In case of a faster temperature rise a higher threshold value may be permitted by agreement with GL.

**D.3.1.15** In rooms with specially high ambient temperatures (e.g. drying rooms), the operation temperature of heat detectors may be up to 130 °C, and up to 140 °C in saunas.

**D.3.1.16** If the fire detection system is not designed for remote and individual identification of detectors, it is not permitted that one zone may monitor more than one deck within the accommodation, service

rooms and control stations, except of a zone which monitors closed staircases. To avoid delay to locate the fire, the number of closed rooms monitored in any one zone is limited to a maximum of 50.

If the fire detection system is designed for remote and individual identification of detectors, the zones may monitor several decks and any number of closed rooms.

**D.3.1.17** A section of fire detectors and manually operated call points shall not be situated in more than one main vertical zone.

**D.3.1.18** Smoke detectors shall be used in passageways, stairways and escape routes.

Smoke detectors in stairways shall be located at least at the top level of the stair and at every second level beneath.

Where detectors are installed in refrigeration rooms, drying rooms, saunas, parts of galleys used to heat food, laundries and other spaces where steam fumes are produced, heat detectors may be used.

**D.3.1.19** Flame detectors shall only be used in addition to the detectors mandatory required.

**D.3.1.20** All fire detectors shall be so designed that they remain serviceable, without the replacement of components, when passed regular testing.

**D.3.1.21** If it is not recognizable at the central fire alarm panel which fire detector has responded, an optical indication shall be provided on each fire detector itself. This indication shall remain displayed until the loop has been reset on the central fire alarm panel.

**D.3.1.22** The fire detectors are to be mounted in such a way that they can operate properly. Mounting places near ventilators, where the operation of fire detectors may be impaired or where mechanical damage is expected, shall be avoided.

Fire detectors mounted to the ceiling shall generally be placed at least 0.5 m away from bulkheads, except in corridors, lockers and stairways.

The maximum monitored area, respectively the maximum distance between fire detectors shall not exceed the following values:

- Heat detectors 37m<sup>2</sup> or distance not more than 9 m
- Smoke detectors 74 m<sup>2</sup> or distance not more than 11 m

The distance from bulkheads shall not exceed:

- 4.5 m for heat detectors
- 5.5 m for smoke detectors

**D.3.1.23** Manually operated call points shall be provided in the accommodation area, the service areas and control stations.

A manually operated call point shall be fitted at every exit. Manually operated call points are not required to be installed for each exit at the navigation bridge, in case, where the fire alarm panel is located at the navigation bridge.

Manually operated call points shall be readily accessible on every deck in the passageways, i.e. no part of the passageway shall be more than 20 m far from a manually operated call point. Service spaces and control stations which have only one access, leading directly to the open deck, shall have a manually operated call point not more than 20 m (measured along the access route using the deck, stairs and/or corridors) from the exit.

**D.3.1.24** A section of fire detectors which covers a control station, a service space or an accommodation space shall not simultaneously include a machinery space of category A or a ro-ro space. A section of fire detectors which covers a ro-ro space shall not include a machinery space of category A.

**D.3.1.25** Fire detectors shall be arranged in sections or detector loops. Activation of a fire detector shall initiate an optical and audible alarm in the central fire alarm panel and at the additional indicating devices.

**D.3.1.26** Cables forming part of the fire detection system shall be so arranged as to avoid to touch galleys, category A machinery spaces and other closed spaces with a high fire risk, except if it is necessary to transmit a fire signal from these spaces, to initiate a fire alarm in these spaces, or to make the connection to the appropriate source of electrical power.

Fire detection systems with a loop-wise indication shall be so designed that

- a loop cannot be damaged at more than one point by a fire
- equipment is available which ensures that a fault in the loop (e.g. wire break, short circuit, earth fault) does not cause failure of the entire control unit
- all possible precautions have been taken to allow the function of the system to be restored in the event of a failure (electrical, electronic, affecting data processing)
- the first fire alarm indicated does not prevent the indication of further alarms by other fire detectors in other loops.

### **D.3.2 Power supply**

**D.3.2.1** The fire detection and fire alarm system shall be supplied from the main- and emergency source of electrical power. Should one supply fail, automatic change-over to the other power supply shall take place in, or close to, the central fire alarm panel. The change-over shall be signalled optically and audibly.

**D.3.2.2** The alarm sounder system, when not an integral part of the fire detection and fire alarm system, shall be supplied from the main- and emergency source of electrical power. In vessels required by **SOLAS** regulation II-1/42 or 43 to be provided with a transitional source of emergency electrical power the alarm sounder system shall also be powered from this power source. The change-over shall be signalled optically and audibly.

#### **D.3.2.3 Continuity of power supply**

**D.3.2.3.1** Operation of the automatic changeover switch or a failure of one of the power supplies shall not result in permanent or temporary degradation of the fire detection and fire alarm system.

**D.3.2.3.2** Where the fire detection and fire alarm system would be degraded by the momentary loss of power, a source of stored energy having adequate capacity shall be provided to ensure the continuous operation during changeover between power supplies.

**D.3.2.3.3** The arrangement of electrical power supplies to an automatic changeover switch shall be such that a fault will not result in the loss of all supplies to the automatic changeover switch. The changeover switch shall be arranged such that a fault in the changeover switch itself will not result in the loss of both power supplies.

**D.3.2.3.4** There shall be sufficient power to permit the continued operation of the system with all detectors activated, but not more than 100 if the total exceeds this figure.

**D.3.2.3.5** When the fire alarm system is not an integral part of the fire detection system, the items [D.3.2.1](#) to [D.3.2.3.3](#) are to be observed only.

#### **D.3.2.4 Emergency supply by an accumulator battery**

**D.3.2.4.1** The fire detection and fire alarm system emergency power may be supplied by an accumulator battery or from the emergency switchboard. Where the system is supplied from an accumulator battery, the arrangements are to comply with the following requirements:

- the accumulator battery shall have the capacity to operate the fire detection system under normal and alarm conditions during the period required by [Section 3, C](#) for the emergency source of power supply.
- the rating of the charge unit, on restoration of the input power, shall be sufficient to recharge the batteries while maintaining the output supply to the fire detection system.
- the accumulator batteries shall be within the fire detection and fire alarm panel or situated in another location suitable to provide a supply in the event of an emergency.

**Note**

*Requirements for Storage Batteries, Chargers and Uninterruptible Power Supplies (UPS) see [Section 20, D](#).*

**D.3.2.4.2** Where the emergency feeder for the electrical equipment used in the operation of the fixed fire detection and fire alarm system is supplied from the emergency switchboard, it shall run from this switchboard to the automatic changeover switch without passing through any other switchboard.

**D.3.3 Fire detection systems with remotely and individually identified detectors**

**D.3.3.1** The fire detection system shall meet the requirements set out in [D.3.1](#) correspondingly.

**D.3.3.2** Where addressable detectors are used, each such detector shall be indicated at the central fire alarm panel, and the audible alarm according to regulations shall be initiated.

**D.3.3.3** Where the detectors in the alarm mode are not all simultaneously indicated at the central fire alarm panel, the central panel shall have the means of scanning all the detectors which have responded in order to establish clearly whether other detectors are in the alarm mode besides the one indicated.

**D.3.3.4** A detection loop shall comprise not more than one fire zone or one watertight division.

**D.3.3.5** If the fire detection system comprises remotely and individually identified detectors the loops may monitor several decks and any number of closed rooms.

**D.3.3.6** For fixed fire detection systems with remotely and individually identifiable fire detectors, a section covering fire detectors in accommodation, service spaces and control stations shall not include fire detectors in machinery spaces of category A or ro-ro spaces.

**D.3.3.7** The detector loop shall be so arranged within a fire section/part of a fire subdivision that in the event of damage, e.g. wire break, a short circuit or a fire, only the affected deck becomes faulty.

The spatial arrangement of the loops shall be submitted for approval.

**D.3.3.8** All arrangements are made to enable the initial configuration of the system to be restored in the event of failure (e.g., electrical, electronic, informatics, etc.).

**D.3.4 Fire detection and alarm systems for cargo ships**

In the GL Rules for [Machinery Installations \(I-1-2\), Section 12, C](#) the following fire detection and alarm systems shall be provided in accordance with the type of construction of the accommodation areas:

**D.3.4.1 Structural fire protection method IC**

A smoke detecting system, including manually operated call points, shall be provided for corridors, staircases and escape routes within the accommodation areas.

**D.3.4.2 Structural fire protection method IIC**

An automatic sprinkler system, including alarm devices in accordance with the GL Rules for [Machinery Installations \(I-1-2\), Section 12, C.3.2](#), shall be provided for accommodation and service rooms (for flow- and fire signals, see also [D.3.4](#)).

A smoke detecting system is additionally to be provided for corridors, staircases and escape routes within the accommodation areas.

Rooms in which no fire hazard exists, e.g. void spaces, sanitary rooms, etc., need not to be monitored.

**D.3.4.3 Structural fire protection method IIIC**

An automatic fire alarm and detection system, including manually operated call points, shall be provided for the entire accommodation area with the exception of those spaces in which no fire hazard exists.

**D.3.5 Fire detection and alarm systems on ships with water spray systems (Sprinkler)**

The GL Rules for [Machinery Installations \(I-1-2\), Section 12, L](#) shall be observed.



**D.3.5.1** Ships which shall be equipped with an automatic water spray system (Sprinkler) in accordance with **SOLAS** shall be additionally provided with a fire detection and alarm system with automatic smoke detectors and manually operated call points with displays on the navigating bridge in accordance with [D.3.1](#).

**D.3.5.2** Where the accommodation and public rooms are fitted with sprinkler systems, the alarm devices shall meet the following requirements:

Each section of sprinklers shall include means of releasing automatically a visual and audible alarm signal at one or more indicating units whenever sprinkler comes into operation. Such units shall indicate in which section a sprinkler has come to operation and shall be centralized on the navigation bridge and in addition, visible and audible alarms from the unit shall be located in a position other than on the navigation bridge, so as to ensure that the indication of the fire is immediately received by the crew.

With regard to self-monitoring and to the electrical power supply, the alarm system shall be designed corresponding to a fire detection system according to [D.3.1](#).

### **D.3.6 Fire detection and alarm systems for unattended machinery spaces**

**D.3.6.1** For unmanned machinery spaces of category A in accordance with the GL Rules for [Automation \(I-1-4\)](#), an automatic fire detection system shall be provided which detects a fire already in its initial stage, e.g. systems with smoke detectors.

General requirements see [D.3.1](#) and [D.3.2](#).

**D.3.6.2** The fire alarm shall be optical and audible recognized on the bridge, in the accommodation and mess areas of the engineer officers or the crew member responsible for the machinery plant and also in the machinery space and it shall be distinguishable from other alarms. The fire alarm shall be executed in machinery space without any time delay.

### **D.3.7 Fire detection and fire alarm systems for cargo holds**

**D.3.7.1** For smoke detection system [D.3](#) is to be observed.

#### **D.3.7.2 Sample extraction smoke detection system**

**D.3.7.2.1** Sample extraction smoke detection systems are subject to mandatory type approval.

**D.3.7.2.2** Each sample extraction smoke detection system shall operate continuously. Systems operating on the scanning principle may be approved, provided that the interval between the detection cycles at the same measuring point is not excessive long.

**D.3.7.2.3** The two power supplies required for the operation of the suction-type smoke detection system shall be monitored for failure. Each power failure shall release an optical and audible signal in the control unit and on the bridge, distinguishable from the smoke detection signal.

**D.3.7.2.4** The control unit shall be located on the bridge or in the main fire control station.

One indicating unit shall be placed on the bridge if the central fire alarm panel is not located there.

The control panel shall clearly distinguish between normal, alarm, acknowledged alarm, fault and silenced conditions.

**D.3.7.2.5** The emission of audible and optical alarms shall continue until they are acknowledged at the control unit. Is only a repeater installed on the bridge, the acknowledgement of the audible alarm on the fire indicating unit shall be independent from the control unit.

**D.3.7.2.6** The sample extraction smoke detection system shall be arranged to automatically reset to the normal operating condition after alarm and fault conditions are cleared.

**D.3.7.2.7** The detection of smoke or other combustion products shall release an optical and audible signal in the control unit and on the bridge.

**D.3.7.2.8** The monitored spaces, including exhaust ventilation ducts, shall be clearly identified at, or close to, the control unit and at the indicating unit if required.

**D.3.7.2.9** Proof is required that the response sensitivity of the suction-type smoke detection system is below 6.65 % obscuration per metre.

**D.3.7.2.10** Two switchover extraction fans are to be provided, each of them shall be sufficient for the duty involved.

**D.3.7.2.11** If explosive gas-/air mixtures or vapours can be sucked in by the smoke detection system, explosion protection shall be provided, see [Sections 16](#) and [17](#).

**D.3.7.2.12** The monitoring device shall enable the observation of smoke in the individual sampling pipes.

**D.3.7.2.13** The air flow through the individual sampling pipes shall be monitored. As far as possible, provision shall be made that equal quantities of air to be drawn from each connected sampling unit.

**D.3.7.2.14** The system shall be of a type that can be tested for correct operation and restored to normal surveillance without the renewal of any component.

**D.3.7.3** Fire detection in cargo spaces for transporting packaged dangerous goods see also the GL Rules for [Machinery Installations \(I-1-2\)](#), [Section 12, P.5](#).

### **D.3.8 Fire detection and alarm systems for waste incineration**

Incinerator spaces, waste storage spaces or combined incinerator and waste storage spaces are to be equipped with fixed fire extinguishing and fire detection systems according to Construction Rules of [Machinery Installations \(I-1-2\)](#), [Section 12](#).

## **D.4 Fixed water-based local application fire-fighting systems (FWBLAFFS)**

**D.4.1** The Construction Rules of [Machinery Installations \(I-1-2\)](#), [Section 12, L.3](#) shall be observed.

Flame detectors, remotely controlled valves, control electronics and fire detection systems used for FWBLAFFS are subject to mandatory type testing.

**D.4.2** The fire detection system shall be selfmonitored. Faults, such as a supply failure, short circuit or wire break in detection loops, the removal of a detector from its base and earth fault in detection loops with all-pole insulation shall be optically and audibly signalled at the central fire alarm panel. Fault alarms shall be acknowledgeable and, wherever possible, distinguishable from a fire alarm.

The emission of audible and optical alarms shall continue until they are acknowledged at the central fire alarms panel. Acknowledgement of the audible fire alarm shall be made before acknowledgement of the optical fire alarm. The acknowledgements of audible and optical fire alarm signals shall be independent of each other. Acknowledgement shall not disconnect the detection loop, nor shall it suppress further alarm signals in other detection loops.

In case the evaluation unit is part of the ship's main fire alarm panel, detectors and control units shall be separated from the main fire alarm system by using separate loops only for the purpose of FWBLAFFS.

**D.4.3** In case of periodically unattended machinery space the FWBLAFFS shall have both automatic and manual release capabilities.

The automatic release shall have a manual stop function in case of a spurious release. The manual release shall be independent from the fire alarm panel.

For continuously manned machinery space only a manual release capability is required.

**D.4.4** The manual release shall be located at easily accessible positions, adjacent to the protected area. Additional to this local release it shall be possible to release the FWBLAFFS from a safe position outside the engine room.

The installation inside the space should not be liable to be cut off by a fire in the protected areas.

### **D.4.5 Detector initiating philosophy**

**D.4.5.1** Fire detectors shall be flame detectors. The viewing angle shall be adjusted to the monitored area only.

**D.4.5.2** For each monitored area two detectors are needed to detect a fire before initiating the release. Activation of a single detector shall cause an alarm. The detectors shall operate with a maximum delay time of 10 seconds.

**D.4.5.3** Other configuration of detectors concerning type and release philosophy shall be agreed with GL.

**D.4.6** The outputs, which activate the valves, shall be designed so that potential faults such as loss of voltage or a broken wire for example shall not create a spurious release.

**D.4.7** Activation of any local application system shall give a visual and distinct audible alarm in the machinery space and at a continuously manned station. This alarm shall indicate the specific system activated.

#### **D.4.8 Ingress protection**

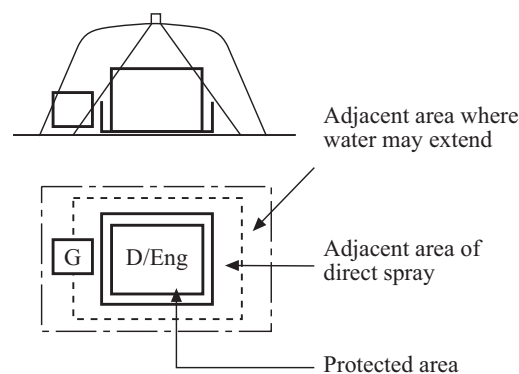

**Fig. 9.1**

#### **Definitions:**

**Protected space:** Is a machinery space where a FWBLAFFS is installed.

**Protected areas:** Areas within a protected space which is required to be protected by FWBLAFFS.

**Adjacent areas:** Areas, other than protected areas, exposed to direct spray or areas, other than those defined above, where water may extend.

Where it is necessary to install equipment within FWBLAFFS protected areas, the following precautions are to be taken:

**D.4.8.1** Operation controls and other electrical and electronic equipment enclosures located in reach of the FWBLAFFS in the protected area and those within adjacent areas exposed to direct spray shall have as a minimum the degree of protection IP44, except where evidence of suitability is submitted to and approved by GL.

**D.4.8.2** IP-degree lower than IP44 for the mentioned electrical and electronic equipment within adjacent areas not exposed to direct spray may be approved with suitable evidence taking into account the design and equipment layout, e.g. position of inlet ventilation openings. The cooling airflow for the equipment is to be assured.

**D.4.8.3** The electrical components of the pressure source for the system shall have a minimum IP-grade of IP54.

**D.4.9** Components of the system such as pumps and valves requiring an external power source shall be supplied by the main power source.

**D.4.10** The FWBLAFFS shall provide means for testing the automatic release without delivering water into the protected areas. Each protected area shall be periodically tested.

**D.4.11** Operating and maintenance instructions for the system and the cleaning interval for the optical parts of the detectors shall be displayed at each operating position and verified in practical operation.

### **D.5 Watertight doors and openings in cargo ships (Watertight door control system)**

For watertight doors and openings relevant to the stability of the ship in the damaged state, control and monitoring devices shall be provided as follows.

**D.5.1** The GL Rules for [Machinery Installations \(I-1-2\), Section 14, F.5](#) shall be observed.

**D.5.2** Optical indicators showing whether the door is closed or open shall be provided at the remote control position. Closing of the door shall be announced on the spot by an audible signal.

**D.5.3** Access doors and access hatch covers normally closed at sea shall be provided with means of monitoring. Indicators shall show locally and on the bridge, whether these doors or hatch covers are open or closed and, if applicable, with all dogs/cleats fully and properly engaged.

**D.5.4** The door position indicating system should be of self-monitoring type and the means for testing of the indicating system should be provided at the position where the indicators are fitted. A failure of control system shall be signalled optical and acoustically on the bridge.

**D.5.5** The operating console on the bridge shall be provided with a system schema from which the arrangement of the watertight doors in the ship can be recognised.

**D.5.6** An indication (i.e. red light) should be placed locally showing that the door is in remote control mode ("doors closed mode"). Special care should be taken in order to avoid potential danger when passing through the door. Signboard/instructions should be placed in way of the door advising how to act when the door is in "doors closed" mode.

### **D.6 Bilge level monitoring**

For the extent and design of the bilge level monitoring see the GL Rules for [Machinery Installations \(I-1-2\), Section 1, E.5](#).

### **D.7 Voyage Data Recorder (VDR)**

**D.7.1** The Voyage Data Recorder should be supplied from the main- and emergency switchboard, see [Section 4, I.9.1](#) and [D.9.3](#).

**D.7.2** Data or alarms for the Voyage Data Recorder have to be free of reactive effects to ship operation.

### **D.8 Ballast water treatment plants**

**D.8.1** Ballast water treatment plants (BWTS) are to be approved by a flag administration acc. to IMO Resolution MEPC.174(58), MEPC.169(57) respectively. The obligation to install a ballast water treatment plant depends on the ballast water capacity and keel laying date of the ship. Refer to International Convention "For The Control And Management of Ship's Ballast Water and Sediments", 2004 – Regulation B-3.

**D.8.2** For BWTS the GL Rules Electrical Installations (I-1-3) are to be observed and [Automation \(I-1-4\)](#), if applicable.

**D.8.3** BWTS shall in addition comply with GL Rules for [Machinery Installations \(I-1-2\), Section 8](#) Pressure vessels and [Section 11](#) Piping systems.

**D.8.4** For the electrical appliances the following documentation to be submitted for approval for each project:

- System description with technical data's,
- wiring diagrams,
- power balance, and
- further documents necessary for the review of the construction.

Section 9 Control, Monitoring and Ship's Safety Systems

---

**D.8.5** On manufacturer's application, GL may issue an approval certificate confirming compliance with GL Rules as referred above.

**D.8.6** In case of BWTS for which compliance with GL Rules have already been confirmed within the GL approval certificate, the typical documentation do not need to be submitted for approval again. Ships related documentation for the individual installation may be necessary for review.

**D.8.7** For a GL approval of a BWTS evidence to be provided, that the components are designed to withstand the environmental strength.



## Section 10 Computer Systems

A	General .....	10-1
B	Requirement Classes.....	10-1
C	System Configuration.....	10-5
D	Documents to be submitted .....	10-8
E	Testing of Computer Systems .....	10-9

### A General

#### A.1 Scope

These Rules apply additionally, if computers are used for tasks essential to the safety of the ship, cargo, crew or passengers and are subject to Classification.

#### A.2 References to other rules and regulations

IEC publication 60092-504 "Electrical Installations in Ships" Part 504: Special features - Control and instrumentation.

#### A.3 Requirements applicable to computer systems

**A.3.1** When alternative design or arrangements deviating from GL Rules are proposed, an engineering analysis, evaluation and approval of the design and arrangements shall be carried out in accordance with a relevant International and/or National Standard acceptable to GL, see also **SOLAS** Ch. II-1 / F, Reg. 55. In such cases, details are to be submitted for consideration.

**A.3.2** Computer systems shall fulfil the requirements of the process under normal and abnormal operating conditions. The following shall be considered:

- danger to persons
- environmental impact
- endangering of technical equipment
- usability of computer systems
- operability of all equipment and systems in the process

**A.3.3** If process times for important functions of the system to be supervised are shorter than the reaction times of a supervisor and therefore damage cannot be prevented by manual intervention, means of automatic intervention shall be provided.

**A.3.4** Computer systems shall be designed in such a way that they can be used without special previous knowledge. Otherwise, appropriate assistance shall be provided for the user.

### B Requirement Classes

#### B.1 General requirements

**B.1.1** Computer systems are assigned, on the basis of a risk analysis, to requirement classes as shown in [Table 10.1](#). This assignment shall be accepted by GL. [Table 10.2](#) shows examples for such an assignment.

**B.1.2** The assignment is divided into five classes considering the extent of the damage caused by an event.

**B.1.3** Considered is only the extent of the damage directly caused by the event, but not any consequential damage.

**B.1.4** The assignment of a computer system to a corresponding requirement class is made under the maximum possible extent of direct damage to be expected.

**B.1.5** In addition to the technical measures stated in this Section also organisational measures may be required if the risk increases. These measures shall be agreed with GL.

**B.2 Risk parameters**

**B.2.1** The following aspects may lead to assignment to a different requirement class, see [Table 10.1](#).

**B.2.1.1 Dependence on the type and size of ship**

- Number of persons endangered
- Transportation of dangerous goods
- Ship's speed

**B.2.1.2 Presence of persons in the endangered area with regard to duration respectively frequency**

- rarely
- often
- very often
- at all times

**B.2.1.3 Averting of danger**

To evaluate the possibility of danger averting, the following criteria shall be considered:

- operation of the technical equipment with or without supervision by a person
- temporal investigation into the processing of a condition able to cause a damage, the alarming of the danger and the possibilities to avert the danger

**Table 10.1 Definition of requirement classes**

Requirement class	Extent of damage		
	Effects on persons	Effects on the environment	Technical damage
1	none	none	insignificant
2	slight injury	insignificant	minor
3	serious, irreversible injury	significant	fairly serious
4	loss of human life	critical	considerable
5	much loss of human life	catastrophic	loss



**Table 10.2 Examples of assignment into requirement classes**

Requirement class	Examples
1	Supporting systems for maintenance Systems for general administrative tasks Information and diagnostic systems
2	"Off line" cargo computers Navigational instruments Machinery alarm and monitoring systems Tank capacity measuring equipment
3	Controls for auxiliary machinery Speed governors "On line" cargo computers, networked (bunkers, draughts, etc.) Remote control for main propulsion Fire detection systems Fire extinguishing systems Bilge draining systems Integrated monitoring and control systems Control systems for tank, ballast and fuel Rudder control systems Navigational systems Course control systems Machinery protection systems/ equipment Ballast water treatment systems
4	Burner control systems for boilers and thermal oil heater Electronic injection systems
5	Systems where manual intervention to avert danger in the event of failure or malfunction is no longer possible and the extent of damage under requirement class 5 can be reached

**B.2.1.4 Probability of occurrence of the dangerous condition**

This assessment is made without considering the available protection devices.

Probability of occurrence:

- very low
- low
- relatively high

**B.2.1.5 Complexity of the system**

- Integration of various systems
- Linking of functional features

**B.2.2** The assignment of a system into the appropriate requirement class shall be agreed on principle with GL.

### B.3 Measures required to comply with the requirement class

**B.3.1** The measures to comply with the requirements of classes 4 and 5 may require for computer equipment and conventional equipment a separation or for the computer equipment a redundant, diversified design.

**Note**

*As a failure of a requirement class 3, 4 and 5 system may lead to an accident from significant to catastrophic severity, the use of unconventional technology for such applications will only be permitted exceptionally in cases where evidence is presented that demonstrates acceptable and reliable system performance to the satisfaction of GL.*

#### B.3.2 Protection against modification of programs and data

**B.3.2.1** The measures required depend on the requirement class and the system configuration (see [Table 10.3](#)).

**B.3.2.2** Computer systems shall be protected against unintentional or unauthorised modification of programs and data.

**B.3.2.3** For large operating systems and programs, other storage media such as hard disks may be used by agreement.

**B.3.2.4** Significant modifications of program contents and system-specific data, as well as a change of version, shall be documented and shall be retraceable.

**Note**

*A significant modification is a modification which influences the functionality and/or safety of the system.*

**B.3.2.5** For systems of requirement class 4 and 5 all modifications, the modifications of parameters too, shall be submitted for approval.

**B.3.2.6** The examples of program and data protection shown in [Table 10.3](#) may be supplemented and supported by additional measures in the software and hardware, for example:

- user name, identification number
- code word for validity checking, key switch
- assignment of authorizations in the case of common use of data / withdrawal of authorizations for the change or erasing of data
- coding of data and restriction of access to data, virus protection measures
- recording of workflow and access operations

**Table 10.3 Program and data protection measures in relation to the requirement class**

Requirement class	Program/Data memory
1	Protection measures are recommended
2	Protection against unintentional/unauthorised modification
3	Protection against unintentional/unauthorised modification and loss of data
4	No modifications by the user possible
5	No modifications possible

## **C System Configuration**

### **C.1 General requirements**

**C.1.1** The technical design of a computer system is given by its assignment to a requirement class. The measures listed below for example, graded according to the requirements of the respective requirement class, shall be ensured.

**C.1.2** For functional units, evidence shall be proved that the design is self-contained and produces no feedback.

**C.1.3** The computer systems shall be fast enough to perform autonomous control operations and to inform the user correctly and carry out his instructions in correct time under all operating conditions.

**C.1.4** Computer systems shall monitor the program execution and the data flow automatically and cyclically e.g. by means of plausibility tests, monitoring of the program and data flow over time.

**C.1.5** In the event of failure and restarting of computer systems, the process shall be protected against undefined and critical states.

### **C.2 Power supply**

**C.2.1** The power supply shall be monitored and failures shall be indicated by an alarm.

**C.2.2** Redundant systems shall be separately protected against short circuits and overloads and shall be selectively fed.

### **C.3 Hardware**

**C.3.1** The design of the hardware shall be clear. Easy access to interchangeable parts for repairs and maintenance shall be provided.

**C.3.2** Plug-in cards and plug-in connections shall be appropriately marked to protect against unintentional transposition or, if inserted in an incorrect position, shall not be destroyed and not cause any malfunctions which might cause a danger.

**C.3.3** For integrated systems, it is recommended that sub-systems be electrically isolated from each other.

**C.3.4** Computers shall preferably be designed without forced ventilation. If forced ventilation of the computers is necessary, it shall be ensured that an alarm is given in the case of an unacceptable rise of temperature.

### **C.4 Software**

**C.4.1** Examples of software are:

- operating systems
- application software
- executable code
- database contents and structures
- bitmaps for graphics displays
- logic programs in PALs
- microcode for communication controllers.

**C.4.2** The manufacturer shall prove that a systematic procedure is followed during all the phases of software development.

**C.4.3** After drafting the specification, the test scheduling shall be made (listing the test cases and establishment of the software to be tested and the scope of testing). The test schedule lays down when, how and in what depth testing shall be made.

**C.4.4** The quality assurance measures and tests for the production of software and the punctual preparation of the documentation and tests shall be retraceable.

**C.4.5** The version of the software with the relevant date and release have to be documented and shall be recognizable of the assignment to the particular requirement class.

## **C.5 Data communication links**

**C.5.1** The reliability of data transmission shall be suitable for the particular application and the requirement class and specified accordingly.

**C.5.2** The architecture and the configuration of a network shall be suitable for the particular requirement class.

**C.5.3** The data communication link shall be continuously self-checking, for detection of failures on the link itself and for data communication failure on the nodes connected to the link. Detected failures shall initiate an alarm.

**C.5.4** System self-checking capabilities shall be arranged to initiate transition to the least hazardous state for the complete installation in the event of data communication failure.

**C.5.5** The characteristics of the data communication link shall be such as to transmit that all necessary information in adequate time and overloading is prevented.

**C.5.6** When the same data communication link is used for two or more essential functions, this link shall be redundant.

**C.5.7** Means are to be provided to ensure protect the integrity of data and provide timely recovery of corrupted or invalid data.

**C.5.8** Switching between redundant links shall not disturb data communication or continuous operation of functions.

**C.5.9** To ensure that data can be exchanged between various systems, standardised interfaces shall be used.

**C.5.10** If approved systems are extended, prove of trouble-free operation of the complete system shall be provided.

## **C.6 Additional requirements for wireless data links**

**C.6.1** These requirements are in addition to the requirements of [C.5](#). Data communication links apply to requirement class 2 using wireless data communication links to transfer data between distributed programmable electronic equipment or systems. For requirement class 3, 4 and 5, the use of wireless data communication links is to be in accordance with [A.3.1](#).

**C.6.2** Functions that are required to operate continuously to provide essential services dependant on wireless data communication links shall have an alternative means of control that can be brought in action within an acceptable period of time.

**C.6.3** Wireless data communication shall employ recognised international wireless communication system protocols that incorporate the following:

- Message integrity: Fault prevention, detection, diagnosis, and correction so that the received message is not corrupted or altered when compared to the transmitted message;
- Configuration and device authentication: Shall only permit connection of devices that are included in the system design;

- Message encryption. Protection of the confidentiality and or criticality the data content;
- Security management. Protection of network assets, prevention of unauthorised access to network assets.

**Note**

*The wireless system shall comply with the radio frequency and power level requirements of International Telecommunications Union and flag state requirements. Consideration should be given to system operation in the event of national local port regulations.*

**C.7 Integration of systems**

**C.7.1** The integration of functions of independent systems shall not decrease the reliability of a single system.

**C.7.2** A defect in one of the subsystems of the integrated system shall not affect the functions of other subsystems.

**C.7.3** A failure of the transfer of data between connected autarkic subsystems shall not impair their independent functions.

**C.8 User interface**

**C.8.1** The handling of a system shall be designed for ease of understanding and user–friendliness and shall follow ergonomic standards.

**C.8.2** The status of the computer system shall be recognisable.

**C.8.3** Failure or shutdown of sub-systems or functional units shall be indicated by an alarm and displayed at every operator station.

**C.8.4** For using computer systems, a general comprehensible user guide shall be provided.

**C.9 Input devices**

**C.9.1** The feedback of control commands shall be indicated.

**C.9.2** Dedicated function keys shall be provided for frequently recurring commands. If multiple functions are assigned to keys, it shall be possible to recognise which of the assigned functions are active.

**C.9.3** Operator panels located on the bridge shall be individually illuminated. The lighting shall be adapted non-glare to the prevailing ambient conditions.

**C.9.4** Where equipment operations or functions may be changed via keyboards appropriate measures shall be provided to prevent an unintentional operation of the control devices.

**C.9.5** If the operation of a key is able to cause dangerous operating conditions, measures shall be taken to prevent the execution by a single action only, such as:

- use of a special key lock
- use of two or more keys

**C.9.6** Competitive control interventions shall be prevented by means of interlocks. The control station in operation shall be indicated as such.

**C.9.7** Controls shall correspond with regard to their position and direction of operation to the controlled equipment.

## **C.10 Output devices**

**C.10.1** The size, colour and density of text, graphic information and alarm signals displayed on a visual display unit shall be such that it may be easily read from the normal operator position under all lighting conditions.

**C.10.2** Information shall be displayed in a logical priority.

**C.10.3** If alarm messages are displayed on colour monitors, the distinctions in the alarm status shall be ensured even in the event of failure of a primary colour.

## **C.11 Graphical user interface**

**C.11.1** Information shall be presented clearly and intelligibly according to its functional significance and association. Screen contents shall be logically structured and their representation shall be restricted to the data which is directly relevant for the user.

**C.11.2** When general purpose graphical user interfaces are employed, only the functions necessary for the respective process shall be available.

**C.11.3** Alarms shall be visually and audibly presented with priority over other information in every operating mode of the system; they shall be clearly distinguishable from other information.

## **C.12 Remote access**

**C.12.1** Remote access during a voyage of a ship shall be used for monitoring purpose and the prior acknowledgment by the ships responsible crew member only.

**C.12.2** If remote software maintenance is arranged for onboard, the installation of software requires the below items and or actions to be fulfilled:

- no modification shall be possible without the acceptance and acknowledgement by the ships responsible crew member (for example the captain) and shall be carried out in a harbour only;
- any revision which may affect compliance with the rules shall be approved by GL and evidence of such shall be available onboard;
- an installation procedure shall be available;
- the security of the installation process and integrity of the changed software shall be verified after the software update is complete;
- a test program for verification of correct installation and correct functions shall be available;
- evidence for the reason for updating a software shall be documented in a software release note;
- in case that the changed software has not been successfully installed, the previous version of the system shall be available for re-installation and re-testing.

## **D Documents to be submitted**

**D.1** For the evaluation of programmable electronic systems of requirement class 2 and higher, documents according to IEC 60092-504 paragraph 10.11 shall be submitted.

**D.2** When alternative design or arrangement is intended to be used, an engineering analysis is to be submitted in addition.

**D.3** Documents for wireless data communication the following data communication equipment shall be submitted in addition:

- Details of manufacturers recommended installation and maintenance practices;
- Network plan with arrangement and type of antennas and identification of location;

- Specification of wireless communication system protocols and management functions; see [C.6.3](#);
- Details of radio frequency and power levels;
- Evidence of type testing;
- On-board test schedule, see [E.8](#).

## **E Testing of Computer Systems**

**E.1** Computer systems of requirement class 2 and higher are subject to mandatory type approval.

**E.2** Evidence, tests and assessments of computer systems have to be carried out in accordance to the requirement class.

The level of tests and witnessing by GL for systems regarding alternative design or arrangements will be determined during the assessment required by [A.3.1](#).

**E.3** By the use of demonstrably service-proven systems and components, the extent of the evidence and tests required may be adapted by agreement.

**E.4** If other proofs and tests are provided by the manufacturer which are of an equivalent nature, they may be recognized.

**E.5** The test schedule of system testing has to be specified and submitted before the hardware and software test will be carried out.

**E.6** Modifications after completed tests which have influence on the functionality and/or the safety of the system have to be documented and retested in accordance to the requirement class.

### **E.7 Tests in the manufacturer's work**

GL reserve the right to demand tests for systems which have safety implications or in case of extensive computer systems or where individual systems are integrated. This test might be a factory acceptance test (FAT) with presence of GL, where function tests, operating conditions simulation, fault simulation and simulation of the application environment will be conducted.

### **E.8 Tests on board**

**E.8.1** Complete system tests

**E.8.2** Integration tests

**E.8.3** For wireless data communication equipment, tests during harbour and sea trials are to be conducted to demonstrate that radio-frequency transmission does not cause failure of any equipment and does not itself fail as a result of external electromagnetic interference during expected operating conditions.

#### **Note**

*Where electromagnetic interference caused by wireless data communication equipment is found to be causing failure of equipment required for requirement class 3, 4 and 5 systems, the layout and/or equipment shall be changed to prevent further failures occurring.*





## Section 11 Lighting and Socket-Outlets

A	General .....	11-1
B	Lighting Installations .....	11-1
C	Socket-Outlets .....	11-2

### A General

**A.1** The design and construction of lighting systems and socket-outlets are also required to conform to the Sections listed below:

[3, C](#) Emergency lighting

[4, H and I](#) Power supply, final subcircuits, navigation lanterns and signalling lanterns

[20, H](#) Construction of socket-outlets

[20, I](#) Construction of lighting fixtures

**A.2** The use of lighting fixtures and socket-outlets currently employed on shore is permitted in accommodation spaces, day rooms and service rooms. They shall, however, conform to [Section 20, H or I](#) as appropriate.

### B Lighting Installations

#### B.1 Design and construction of the lighting installation

**B.1.1** A sufficient number of lighting fixtures shall be provided to achieve a good level of illumination.

**B.1.2** A main lighting system shall be installed which is supplied from the main electrical power source and illuminates all areas accessible to the passengers and crew.

**B.1.3** The arrangement of the main- and emergency lighting systems (sources of electrical power, associated transformers, switchboards and central lighting distribution panels) shall be such that a fire or other incident does not cause the failure of both systems, i.e. the aforementioned components of the main and emergency lighting systems shall not be located in the same rooms.

**B.1.4** Following a failure of the main power supply, the emergency lighting system shall cut in automatically. Local switches may be provided only where the ability to switch off the emergency lighting is required, e.g. in the wheelhouse.

**B.1.5** Ro-Ro passenger ships shall be provided with an additional emergency lighting system, see [Section 16, F](#).

**B.1.6** Emergency lighting fixtures shall be marked as such for easy identification.

**B.1.7** Where, in accordance with **SOLAS**, a ship is divided into main fire zones, at least two circuits shall be provided for the lighting of each main fire zone, and each of these shall have its own power supply circuit. One circuit can be supplied from the emergency switchboard, if this is permanently in service. The supply circuits shall be routed in such a way that a fire in one main fire zone does not interfere with the lighting of the other zones.

### **B.1.8 Cargo holds, bunkers and pipe tunnels**

For a permanently installed lighting system, switches with clearly marked positions or indicating lights shall be provided for each final subcircuit or for each area.

The lighting fixtures shall be provided with unbreakable covers and so mounted that they cannot be damaged when work is being carried out.

Lighting fixtures in cargo holds shall be installed in such a way that, when properly used, there is no overheating of the lighting fixtures or their surroundings, even when the ship is loaded.

### **B.1.9 Illumination for pilot transfer**

Adequate illumination shall be provided for the outboard transfer arrangements, the deck region where persons come on board or leave and at the control positions for the mechanical pilot hoist.

## **B.2 Mounting of lighting fixtures**

**B.2.1** The lighting fixtures on the open deck which are used while the ship is travelling, shall be so located that they do not impede the navigation. If necessary they shall be fitted with reflectors.

**B.2.2** Within arm's reach of showers and bathtubs up to 1.2 m from the shower head and/or 0.6 m from the tub-rim vertical surface and up to a height of 2.25 m, lighting fixtures shall only be installed if their degree of protection is at least IP55.

Switches shall not be installed within arm's reach.

**B.2.3** For lighting fixtures mounted in corridors, the head clearance shall be at least 1.80 m.

**B.2.4** All lighting fixtures shall be so mounted that combustible parts are not ignited by the generated heat, and they themselves are not exposed to damage.

The minimum distances indicated on the lighting fixtures shall be respected.

Where no minimum distances are specified, the minimum distances in the direction of radiation indicated in [Table 11.1](#) shall be applied for lighting fixtures in accordance with IEC publication 60598-1 Luminaires, Part 1: General Requirements and Tests.

**Table 11.1 Minimum distances for the mounting of lighting fixtures**

<b>Rated power [W]</b>	<b>Minimum distance [m]</b>
up to and incl. 100	0.5
over 100 up to and incl. 300	0.8
over 300 up to and incl. 500	1.0

## **C Socket-Outlets**

### **C.1 General**

**C.1.1** The supply for socket-outlets in the accommodation, day rooms and service rooms (250 V) are to be run from lighting distribution panels. The maximum fuse rating for a circuit is 16 A.

**C.1.2** For the sockets of distribution systems with different voltages and/or frequencies, non-interchangeable plugs and socket outlets shall be used.

**C.1.3** Plug-in connections shall not be installed below the floor in engine rooms or boiler rooms.

**C.1.4** Socket outlets for power circuits over 16 A AC or 10 A DC shall be interlocked in such a way that the plug can be neither inserted nor withdrawn when the socket contacts are live.

## **C.2 Shower rooms and bathing rooms**

**C.2.1** In shower rooms and bathing rooms the electrical equipment shall be installed in accordance with IEC publication 60364-7-701.

**C.2.2** The minimum degree of protection against foreign bodies and water shall be according to [Table 11.2](#).

**Table 11.2 Minimum degree of protection against foreign bodies and water in zone 0, 1 and 2**

<b>Zone</b>	<b>Degree of protection of the needed electrical equipment in shower rooms and bathing rooms</b>
0	IP X7
1	IP 55
2	IP 34

## **C.3 Cargo holds**

Sockets in cargo holds shall be installed only in locations with sufficient protection against mechanical damage.

## **C.4 Container connections**

**C.4.1** Socket connections for refrigerated containers shall be supplied from own subdistribution panels. At the subdistribution panels shall be indicated whether these distribution panels are live and which supply circuit is switched on.

**C.4.2** Several socket outlets may be grouped together for common supply via one power cable, provided that the individual connections are protected at site against overcurrent and short circuit, and the supply cable is rated for the total power demand. For details, see [Section 12, C](#).



## Section 12 Cable Network

A	Choice of Cables and Wires .....	12-1
B	Determination of Conductor Cross-Sections .....	12-2
C	Rating, Protection and Installation of Circuits .....	12-4
D	Installation .....	12-7
E	Requirements for Busbar Trunking Systems intended for the Electrical Supply of Distribution Panels and Single Consumers .....	12-15

### A Choice of Cables and Wires

#### A.1 General instructions

Cables and conductors shall conform to the requirements stated in [Section 20, F](#).

#### A.2 Rated voltage

The rated voltage of a cable shall be not less than the operating voltage of the relevant circuit.

In insulated distribution systems, the outer conductor voltage of the system shall be deemed to be the rated voltage of the cable between a conductor and the ship's hull.

#### A.3 Temperatures

At places where higher ambient temperatures are expected, cables shall be used whose permissible temperature is at least 10 K above the maximum anticipated ambient temperature.

A correction of the permissible current rating shall be made in accordance with [Table 12.1](#).

Cables on diesel engines, turbines, boilers, etc., where there is danger of excessive heating, shall be so routed that they are protected against inadmissible external heating stress, or cables are to be used which are approved for the maximum arising ambient temperature.

#### A.4 Mechanical protection

The choice of cables shall consider the mechanical stressing, see [D](#).

#### A.5 Mobility

**A.5.1** Machines or equipment mounted on vibration absorbers (rubber or springs) shall be connected with cables or wires of sufficient flexibility and installed with compensating bends.

**A.5.2** Mobile equipment shall be connected via flexible cables, e.g. of type HO7RN-F, CENELEC HD 22 or equivalent.

For voltages above 50 V, flexible connecting cables or -wires intended for equipment without double insulation shall also include an earthing conductor.

The earthing conductor shall have a green/yellow coloured marking.

**A.5.3** For mobile parts of installations or lifting wheelhouses supplied via scissor-type cable supports, suspended loops, festoon systems, etc., the use of suitable, flexible cables is required.

#### A.6 Application of cables and wires

Cables and wires shall be used according to the application categories, [Table 12.2](#).

## B Determination of Conductor Cross-Sections

### B.1 Rating method on the basis of maximum current-carrying capacity

Conductor cross-sections are to be determined on the basis of load with due regard for C.1 to C.3.

The calculated current shall be equal to, or smaller than, the permissible current for the chosen conductor cross-section.

The permissible current-carrying capacities of cables listed in Tables 12.6 to 12.9 apply to an ambient temperature of 45 °C and to the stated permissible operating temperature of the cables or wires.

**B.1.1** The current-carrying capacities listed in Tables 12.6 to 12.9 apply to flat cable configurations containing not more than 6 cables laid side by side, or to groupings of not more than 3 cables or insulated wires, as follows:

Flat arrangement:

○○○○○ ○○○○○ etc.

Groupings of not more than 3 cables:

○○ ○○ etc.  
○○ ○○ or ○○○○ etc.

The triple groups shall be laid in each direction with a spacing corresponding to at least one outer diameter of the largest cable or largest insulated wire.

**B.1.2** If the specified configurations cannot be adhered to, or the passage of cooling air is not assured, the current-carrying capacity shall be reduced to 85 % of the values given in the tables, and the overcurrent protection shall be modified accordingly.

Exceptions are made for bundles of cables and insulated wires which are not part of the same circuit and/or which will not be loaded with their rated currents simultaneously.

**Table 12.1 Corrective factors for rating capacity of conductor cross-sectional areas**

Permissible operating temperature		Ambient temperature [°C]										
		35	40	45	50	55	60	65	70	75	80	85
[°C]	Table	Correction factor										
60	12.6	1.29	1.15	1.0	0.82	–	–	–	–	–	–	–
75	12.6	1.15	1.08	1.0	0.91	0.82	0.71	0.58	–	–	–	–
80	12.7	1.13	1.07	1.0	0.93	0.85	0.76	0.65	0.53	–	–	–
85	12.7, 12.8	1.12	1.06	1.0	0.94	0.87	0.79	0.71	0.61	0.50	–	–
90	12.9	1.10	1.05	1.0	0.94	0.88	0.82	0.74	0.67	0.58	0.47	–
95	12.9	1.10	1.05	1.0	0.95	0.89	0.84	0.77	0.71	0.63	0.55	0.45

**Table 12.2 Application categories for power, control and communication cables**

Category	Range of application	Remarks
1	Within the ship in all areas and on open deck	Cables with shielding and outer sheath
2	Within the ship in all areas, except where EMC requirements exist and not in hazardous areas	Cables without shielding
3	Only in crew and passenger accommodation/day rooms, for final supply circuits of lighting, sockets and space heating	Cables without shielding, with single-wire (solid) conductors up to 4 mm <sup>2</sup>
4	At diesel engines, turbines, boilers and other devices with higher temperatures	Heat-resistant cables (wires)
5	Other application areas, not specified in 1 - 4	See type test certificate

**B.1.3** For the laying of single-core cables and wires in single-phase and three-phase alternating current systems, see [D.7](#).

**B.1.4** Cables whose maximum permissible conductor temperatures differ from each other by more than 5 K may be bundled together only if the permissible current-carrying capacity of the lowest-capacity type is taken as the rating-basis for all cables.

**B.1.5** Parallel cables are permitted only with conductor cross-sections of 10 mm<sup>2</sup> (AWG 7) and over.

Only cables of the same length and having the same conductor cross-section may be installed as parallel cables. Equal current-distribution shall be ensured.

Parallel cables may be loaded to the sum of their individual current-carrying capacities, and shall be common fused.

## **B.2 Rating on the basis of voltage drop**

**B.2.1** Under normal service conditions, the voltage drop between the busbars (main/emergency switchboard) and the consumers shall not exceed 6 %, or 10 % in the case of battery-supplied networks of 50 V or less. Navigation lights are subject to the requirements of [Section 4, I.6](#).

**B.2.2** Where short-term peak loads are possible, for instance due to starting processes, it is to ensure that the voltage drop in the cable does not cause malfunctions.

## **B.3 Consideration of current peaks**

The cross-section shall be so chosen that the conductor temperatures do not exceed the maximum limits specified below neither under short-circuit nor start-up conditions:

for PVC (60 °C) 150 °C

for PVC (75 °C) 150 °C

for EPR (90 °C) 250 °C

(EPM or EPDM)

for XLPE (VPE) (90 °C) 250 °C

for silicone (95 °C) according to specification

The figures in brackets are the permissible operating temperatures at the conductor in continuous operation.

## **B.4 Minimum cross-sectional areas and their current-carrying capacity**

**B.4.1** The conductor cross-sections indicated in [Table 12.3](#) are the minimum cross-sections for external cabling respective for internal wiring, e.g. of switchgear and consoles.

**B.4.2** The maximum current-carrying capacity of conductor cross-sections for external cabling is indicated in [Table 12.6](#). For cables and wires in telecommunications systems apply the values listed in [Table 12.4](#).

A maximum permissible current of 1.0 A is applicable to the 0.2 mm<sup>2</sup> (AWG 24) conductor cross-section regardless of the number of cores.

**B.4.3** In accommodation and day rooms, flexible cables with a conductor cross-section of not less than 0.75 mm<sup>2</sup> (AWG 18) may also be used for the connection of movable equipment with a current consumption of up to 6 A.

**B.4.4** For ship's hull return, see [Section 1, G.3](#) and [Section 4, I.1.2](#).

**B.4.5** For earthing conductors, see [Section 1, K](#).

**B.4.6** Neutral conductors in three-phase distribution systems shall be in cross-section equal to at least half the cross-section of the outer conductors. If the outer conductor cross-section is 16 mm<sup>2</sup> (AWG 5) or less, the cross-section of the neutral conductor shall be the same as that of the outer conductors.

**B.4.7** Exciter equalizer cables for three-phase generators in parallel operation shall be rated for half the nominal exciter current of the largest generator.

## **C Rating, Protection and Installation of Circuits**

### **C.1 Individual consumers and rating of final subcircuits**

**C.1.1** Cables shall be rated according to the expected operating load based on the connected load and the mode of operation of the consumers. The values shown on the name plate of a consumer are valid.

**C.1.2** The following loads are to be assumed for 250 V AC lighting circuits and socket-outlet circuits:

- for each lighting point, at least 100 W
- for each socket-outlet, at least 200 W

### **C.2 Consideration of a diversity factor for group supply cables**

**C.2.1** If all the connected consumers in a part of the system are not simultaneously in operation, a diversity factor may be used for determining the cross-section.

A diversity factor is the ratio of the highest operating load expected under normal operating conditions to the sum of the rated loads of all the connected consumers.

**C.2.2** The load ascertained by the application of a diversity factor shall be deemed to be the continuous load for the determination of the cross-section.

**C.2.3** The diversity factors shown in [Table 12.5](#) may be applied to the rating of cables used to supply groups of winches.

The values given in the [Table 12.5](#) shall be related to the rated motor current, or, in the case of motors with several different outputs, to the current corresponding to the highest output.



**C.2.4** Group supply feeders for hydraulic winches shall be rated for the installed power without the application of a diversity factor.

**C.2.5** The cross-section of group supply feeders for cargo cranes shall be determined in the same way as for cargo winches.

**C.2.6** For cargo cranes with one drive motor, the supply cable shall be rated according to the current rating of the maximum load capacity.

**C.2.7** Where cargo cranes have more than one motor, the feeder cable to an individual crane can be rated as follows:

The value of the current used for cross-section determination shall be equal to 100 % of the output of the lifting motors plus 50 % of the output of all the other motors. With this calculated current the cross-section of the cable shall be selected for continuous operation.

**C.2.8** If current diagrams for the various operating conditions of cranes or groups of winches have been ascertained, the average current based on the diagram may be used instead of application of a diversity factor.

**C.2.9** Cross-sections of group supply feeders for refrigerated container socket-outlets are to be designed in accordance with power calculation considering the corresponding diversity factor (see [Section 3, B](#)).

### C.3 Cables overload protection

**C.3.1** Cables shall be protected against short circuit and overcurrent.

**C.3.2** Rating and setting of the protection devices shall be in compliance with the requirements in [Section 4](#).

**C.3.3** Cables protected against overcurrent at the consumers side require only short-circuit protection at the supply side.

For steering gear, see [Section 7, A](#).

**Table 12.3 Minimum cross-sectional areas**

	Nominal cross-section			
	external wiring		internal wiring	
	international	AWG	international	AWG
Power, heating and lighting systems	1.0 mm <sup>2</sup>	17	1.0 mm <sup>2</sup>	17
Control circuits for power plants	1.0 mm <sup>2</sup>	17	1.0 mm <sup>2</sup>	17
Control circuits in general, safety systems in accordance with <a href="#">Section 9</a>	0.75 mm <sup>2</sup>	18	0.5 mm <sup>2</sup>	20
Telecommunications equipment in general, automation equipment	0.5 mm <sup>2</sup>	20	0.1 mm <sup>2</sup>	28
Telephone and bell installations, not relevant for the safety of the ship or crew call installations	0.2 mm <sup>2</sup>	24	0.1 mm <sup>2</sup>	28
Data bus and data cables	0.2 mm <sup>2</sup>	24	0.1 mm <sup>2</sup>	28

**Table 12.4 Rating of telecommunication and control cables**

Number of core pairs [2 cores]	Number of cores	Nominal cross-section 0.5 mm <sup>2</sup> (AWG 20)		Nominal cross-section 0.75 mm <sup>2</sup> (AWG 18)	
		Permissible load	Rated fuse current	Permissible load	Fuse rating
		A max.	A	A max.	A
1 x 2	2	–	–	10.5	10
2 x 2	4	5	6	7.5	6
4 x 2	8	4	4	6	6
7 x 2	14	3.5	4	4.5	4
10 x 2	20	3	4	4	4
14 x 2	28	3	2	3.5	4
19 x 2	38	3	2	3.5	4
24 x 2	48	2	2	3	2
48 x 2	96	2	2	–	–

The values in the Table relate to an ambient temperature of 45 °C and a conductor temperature of 85 °C.

**C.3.4** Exciter cables for DC motors and DC generators operating in parallel shall not be fused.

Exciter cables for individually connected DC generators and synchronous three-phase alternators shall be fused only if there are special reasons for it, e.g. where the cables are passing through various compartments of the ship.

**C.4 Separation of circuits**

**C.4.1** A separate cable shall normally be provided for each circuit having its own overcurrent- and short-circuit protection. Deviating from this requirement the following may be combined in a common cable:

- a main circuit and its control circuits which have their tapping off after the main switch
- various control circuits laid separately from the main circuits
- various main circuits and their control circuits belonging to a common system, e.g. for several drives of an air-conditioning system, if all the cores of the cable can be centrally disconnected from the supply

**Table 12.5 Diversity factors during operation with winches**

Number of winches	The following values shall be used for determining the cable cross-section	
	Winches with DC motors	Winches with induction motors
2	100 % of the largest motor + 30 % of the second motor, or, with identical motors, 65 % of their combined full current	100 % of the largest motor + 50 % of the second motor, or, with identical motors 75 % of their combined full load current
3	100 % of the largest motor + 25 % of the remaining motors, or, with identical motors 50 % of their combined full current	100 % of the largest motor + 50 % of the remaining motors, or, with identical motors 67 % of their combined full current

**Table 12.5 Diversity factors during operation with winches** *(continued)*

Number of winches	The following values shall be used for determining the cable cross-section	
	Winches with DC motors	Winches with induction motors
4	100 % of the largest motor + 20 % of the remaining motors, or, with identical motors 40 % of their combined full current	100 % of the largest motor + 50 % of the remaining motors, or, with identical motors 62 % of their combined full current
5	100 % of the largest motor + 20 % of the remaining motors, or, with identical motors 36 % of their combined full current	100 % of the largest motor + 50 % of the remaining motors, or, with identical motors 60 % of their combined full current
6 and more	33 % of the combined full load current	58 % of the combined full load current

**C.4.2** Separate cables shall be provided for safety voltage circuits.

**C.4.3** Separate cables shall be provided for intrinsically safe circuits.

**C.5 Cable laying for circuits**

**C.5.1** For single-phase and three-phase AC systems, multi-core cables are to be used wherever possible.

**C.5.2** Should it be necessary to lay single-core cables for the carriage of more than 10 A in single-phase or three-phase AC circuits, the special requirements of [D.7](#) shall be fulfilled.

**C.5.3** In three-phase systems without hull return, three-core cables shall be used for three-phase connections; four-core cables are required for circuits with loaded neutral point.

**C.5.4** In three-phase systems with hull return the asymmetry of the currents in the three conductors of three-core cables shall not exceed 20 A (see [Section 4, I](#)).

**C.5.5** In DC systems without hull return multi-core cables shall be provided in all cases of smaller cross-sections.

Where single-core cables are used for large cross-sections, the outgoing- and return-cables shall be laid as close as possible to each other over their entire length to avoid magnetic stray fields.

**C.5.6** The generator cables, all cables run from the main or emergency switchboard or an auxiliary switchboard, and all interconnecting cables for essential equipment, shall be laid as far as possible uninterrupted in length to the distribution panels or to the equipment.

**C.5.7** The cables of intrinsically safe circuits shall be laid at a distance of at least 50 mm separated from the cables of non-intrinsically safe circuits. The laying of intrinsically safe circuits together with non-intrinsically safe circuits in a pipe is not permitted.

Cables of intrinsically safe circuits shall be marked.

**D Installation**

**D.1 Routing of cables**

**D.1.1** The routes of cables shall be such that cables are laid as straight as possible and are not exposed to mechanical damage.

**D.1.2** For bends, the minimum bending radius permitted by the manufacturer shall be observed. The radius shall be not smaller than 6 times of the outer diameters of the cables.

**D.1.3** Heat sources such as boilers, hot pipes etc. shall be bypassed, so that the cables are not subjected to additional heating. If this is not possible, the cables are to be shielded from thermal radiation.

**D.1.4** The tensile stress of the cables at long cable runs caused by thermal expansion and/or movement of ship structure shall not damage the cables, cable runs or cable penetration systems.

At long and straight cable runs like in passage ways or void spaces etc. or at other positions where unacceptable tensile stresses are liable to occur at the cables and cable trays, precautions shall be taken to distribute the expansion movement uniformly over a cable loop provided for such purpose, so that there is no damaging of the cables, cable runs or cable penetration systems.

The diameter of the cable loop shall be at least 12 times the diameter of the thickest cable. In each division should be provided at least one cable loop.

**D.1.5** Cables shall not be laid within room isolations.

Exceptions are permitted for lighting, socket-outlets and control circuits in accommodation and refrigerated rooms, provided that the maximum loading of the cables does not exceed 70 % of their current carrying capacity.

**D.1.6** Where, for safety reasons, a system shall have duplicated supply- and/or control cables, the cable routes are to be placed as far apart as possible.

**D.1.7** Supply cables for emergency consumers shall not be run through fire zones containing the main source of electrical power and associated facilities. Exceptions are made for cables for supply of emergency consumers located within such areas.

**D.1.8** The electrical cables to the emergency fire pump shall not pass through the machinery spaces containing the main fire pumps and their sources of power and prime movers. If the electrical cables to the emergency fire pump pass through other high fire risk areas, they are to be of a fire resistant type.

**D.1.9** Cables for supply of essential equipment and emergency consumers, e.g. lighting and important communications- and signalling systems shall, wherever possible, bypass galleys, laundries, category A engine rooms and their casings and areas with a high fire risk.

On ships whose construction or small size precludes fulfilment of these requirements, measures shall be taken to ensure the effective protection of these cables where they have to be run through the rooms mentioned above, e.g. by the use of fire-resistant cables or by flame-retardant coating such an installation shall be approved by GL.

**D.1.10** Cable installation for medium-voltage equipment [Section 8, E](#) is to be observed.

## **D.2 Fastening of cables and wires**

**D.2.1** Cable trays and cableways shall be made preferably of metallic materials which are protected against corrosion.

Cables and wires shall be fastened with corrosion-resistant, flame retardant clips or bindings. Exceptions are made for cables which are laid in pipes or cable ducts.

Cables and wiring shall be installed and supported in such a manner as to avoid chafing or other damage.

This also applies for the installation of cables and wires in connection boxes of electrical equipment and switchboards.

**D.2.2** Suitable materials shall be placed together when fasten cables to aluminium walls.

Clips for mineral-insulated cables with copper sheaths shall be made of copper alloy if they are in electrical contact with the latter.

**D.2.3** Single-core cables are to be fastened in such a manner that they are able to withstand the electrodynamic forces occurring in the event of short circuits.

**D.2.4** The distances between the supports for cable racks and the fastenings used shall be selected with due regard to the cable type, cross-section and number of cables concerned.

**D.2.5** Where cables suspended are fastened by the use of plastic clips or straps, metallic cable fixing devices, spaced not more than 1 m apart shall be used additionally in the following areas:

- generally in escape routes and emergency exits, on the open deck, in refrigeration rooms and in boiler rooms
- cargo holds, machinery rooms, control rooms and service rooms where bunched cables are fastened on riser cable trays or under the cable trays

**D.2.6** Cable trays/protective casings made of plastic materials shall be tightened in such a way that they do not obstruct together with the cables the escape routes in case of fire, see [D.6.2](#).

The suitability of cable trays shall be proved, [Section 21, E.5.1.1 d](#)). Installation, see also [D.2.5](#).

**D.2.7** It is recommended, that cables and cable bunches shall not be painted.

If they still would be painted the following shall be observed:

- the paint shall be compatible with the material of the cables, and
- the flame-retardant property respectively fire resistance of the cables and cable bunches shall be maintained.

### **D.3 Stress relief**

Cables shall be so installed that any tensile stresses which may occur remain within the permitted limits. This shall be particularly observed for cables on vertical runs or in vertical conduits.

### **D.4 Protection against mechanical damage**

**D.4.1** Cables in cargo holds, on open decks and at positions where they are exposed to a particularly high risk of mechanical damage shall be protected by pipes, covers or closed cable ducts.

**D.4.2** Cables passing through decks shall be protected against damage by pipe sockets or casings extending to a height of about 200 mm over deck.

### **D.5 Installation of cables and wires in metallic pipes, conduits or closed metal ducts**

**D.5.1** If cables are installed in pipes or ducts, attention shall be paid that the heat from the cables can be dissipated into the environment.

**D.5.2** The inside of the pipes or ducts shall be smooth, and their ends shaped in such a way as to avoid damage to the cable sheath.

They shall be effectively protected inside against corrosion. The accumulation of condensation water shall be avoided.

**D.5.3** The clear width and any bends shall be such that the cables can be drawn through without difficulty. The bending radius of the pipe shall be equivalent to at least 9 times of the outer cable diameter.

**D.5.4** Where pipes or ducts passing through areas where panting is expected, suitable means of compensation shall be provided.

**D.5.5** Not more than 40 % of the clear cross-section of pipes and ducts shall be filled with cables. The total cross-section of the cables is deemed to be the sum of their individual cross-sections based on their outside diameters.

**D.5.6** Pipes and ducts shall be earthed.

**D.5.7** Single-core cables of single- and three phase AC systems shall be provided with plastic outer sheaths if they are installed in metallic pipes or ducts.

**D.5.8** Long cable ducts and pipes shall be provided with a sufficient number of inspection- and pull boxes.

## D.6 Installation in non-metallic pipes and ducts

**D.6.1** Cable trays/protective casings made of plastic materials are to be type tested in accordance with IACS UR E 16, see [Section 21, E.5.1.1 d](#)).

### Note

*"Plastics" means both thermoplastic and thermosetting plastic materials with or without reinforcement, such as polyvinyl chloride (PVC) and fibre reinforced plastics (FRP).*

*"Protective casing" means a closed cover in the form of a pipe or other closed ducts of non-circular shape.*

*Applicable for pipes with a diameter of more than 80 mm.*

**D.6.2** Non-metallic pipes or cable ducts shall be made of flame-retardant material.

Additional requirements for passenger vessels in [Section 14, F.2.1](#) are to be observed.

**D.6.3** Cable trays/protective casings made of plastic materials are to be supplemented by metallic fixing and straps such that in the event of a fire they, and the cables affixed, spaced not more than 1 m apart are prevented from falling and causing an injury to personnel and/or an obstruction to any escape route.

### Note

*When plastic cable trays/protective casings are used on open deck, they are additionally to be protected against UV light.*

**D.6.4** The load on the cable trays/protective casings is to be within the Safe Working Load (SWL). The support spacing is not to be greater than the Manufacturer's recommendation nor in excess of spacing at the SWL test. In general the spacing is not to exceed 1 meter.

### Note

*The selection and spacing of cable tray/protective casing supports are to take into account:*

- *cable trays/protective casings' dimensions*
- *mechanical and physical properties of their material*
- *mass of cable trays/protective casings*
- *loads due to weight of cables, external forces, thrust forces and vibrations*
- *maximum accelerations to which the system may be subjected*
- *combination of loads*

**D.6.5** The sum of the cables' total cross-sectional area, based on the cables' external diameter, is not to exceed 40 % of the protective casing's internal cross-sectional area. This does not apply to a single cable in a protective casing.

## D.7 Laying of single-core cables and wires in single-phase and three-phase AC systems

In cases where use of multi-core cables is not possible, single-core cables and -wires may be permitted for installation if the following provisions are made and the requirements of IEC publication 60092-352 are observed:

**D.7.1** The cables shall not be armoured or shrouded with magnetic material.

**D.7.2** All conductors belonging to one circuit shall be run together in the same pipe or duct, or clamped by common clamps, unless the clamps are made of non-magnetic materials.

**D.7.3** The cables forming a circuit shall be laid immediately beside of each other and preferably in triangular configuration. If spacings cannot be avoided, the spacings shall not exceed one cable diameter.

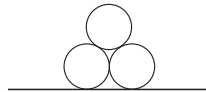

**D.7.4** No magnetic material shall be placed between single-core cables passing through steel walls. No magnetic materials shall be between the cables of deck and bulkhead penetrations. Care shall be taken to ensure that the distance between the cables and the steel wall is at least 75 mm, unless the cables belonging to the same AC circuit are installed in trefoil formation, see [D.7.3](#)

For the installation of single core parallel cables between the cable groups these measures are not necessary, if the cable groups are arranged in trefoil formation.

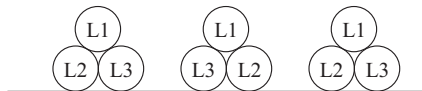

**D.7.5** Single-core parallel cables shall be of the same length and cross-section. Furthermore, to avoid unequal division of the current, the cables of one phase shall be laid, as far as is practicable, alternately with the cables of the other phases, e.g. in the case of two cables for each phase:

L1, L2, L3, L3, L2, L1 or L1, L2, L3  
 L3, L2, L1  
 or L3, L1, L2 or L2, L3, L1  
 L2, L1, L3 L1, L3, L2

**D.7.6** To balance the impedance of the circuit in single-core cables more than 30 m long and with a cable cross-section of more than 150 mm<sup>2</sup>, the phases are to be alternated at intervals of not more than 15 m.

**D.7.7** For single-core cables, metallic sheaths are to be insulated from each other and from the ship's hull over their entire length. They shall be earthed at one end only, except earthing is required at both ends for technical reasons (e.g. for medium voltage cables). In such cases the cables shall be laid over their entire length in triangular configuration.

## **D.8 Bulkhead and deck penetrations**

**D.8.1** Cable penetrations shall conform to the partition categories laid down by **SOLAS**, and shall not impair the mechanical strength or watertightness of the bulkhead.

**D.8.2** Bulkhead and deck penetrations shall have been type-tested by GL. The GL Guidelines for [Test Requirements for Sealing Systems of Bulkhead and Deck Penetrations \(VI-7-4\)](#) are to be taken into consideration.

**D.8.3** The cables shall not occupy more than 40 % of the cross-section of a penetration or as GL type tested according to GL Guidelines for [Test Requirements for Sealing Systems of Bulkhead and Deck Penetrations \(VI-7-4\)](#) and mentioned in the corresponding GL type approval certificate.

**D.8.4** Vertical cable ducts shall be so constructed that a fire on one deck cannot spread through the duct to the next higher or lower deck (see also [D.14.2.2](#)).

## **D.9 Cables in the vicinity of radio-communication and -navigation equipment**

**D.9.1** Except where laid in metallic pipes or ducts, cables and wires with metal sheaths or metal braiding are to be used above the uppermost metallic deck and in positions where the cables and wires are not separated by metallic bulkheads or decks from aerials, aerial downleads, the radio room, direction finder or other radio navigation- or receiving equipment. The metallic sheaths and shields are to be earthed.

**D.9.2** Only cables required in the radio room shall be laid there. If cables without a braid shielding have to be run through a radio room, they shall be installed in a continuous metallic pipe or -duct which is earthed at the entrance to and exit from the room.

**D.9.3** Single-core cables are not permitted in the radio room.

**D.9.4** If the radio equipment is installed on the bridge, the requirements stated above are to be complied with as and where applicable.

#### **D.10 Magnetic compass zone**

All electrical cables, wires, machines and apparatuses shall be laid, installed or magnetically shielded in order to avoid inadmissible interference (deviation < 0.5 degree) with the magnetic compass.

#### **D.11 Cable installation in refrigeration spaces**

**D.11.1** Only cables with outer sheaths resistant to corrosion and cold-resistant shall be laid in refrigerated rooms.

**D.11.2** Where cables are led through the thermal isolation, [D.1.5](#) shall be observed.

**D.11.3** Only cables without hull return are permitted in refrigerated rooms and in the associated air cooler spaces. The earthing conductors shall be run together with the other cables from the relevant distribution panel.

#### **D.12 Earthing of the braided screens of cable network and accessories**

**D.12.1** Metallic cable sheaths, armouring and shields in power installations shall be electrically connected to the ship's hull at each end; single-core cables shall be earthed at one end only. For cables and wires for electronic equipment, the manufacturer's recommendations shall be observed, earthing at one end only is recommended.

**D.12.2** Electrical continuity of all metallic cable coverings shall also be maintained inside of cable junction- and connection boxes.

**D.12.3** Metallic cable sheaths, armouring and shields shall be earthed, preferably by the use of standard cable gland fittings designed for that purpose, or by suitable equivalent clips or joints.

**D.12.4** Metallic cable sheaths, armourings and shields shall in no case be deemed to constitute earthing conductors for the protective earthing of the connected electrical equipment.

#### **D.13 Cable joints and branches**

**D.13.1** Cables shall be extended only with the approval of GL. The used material shall maintain the flame-retardant and where required the fire-resistant properties of the cables.

**D.13.2** Junction- and distribution boxes shall be accessible and marked for identification.

**D.13.3** Cables for safety low voltage shall not pass a junction- or distribution box together with cables for higher voltage systems.

**D.13.4** The terminals for different types of systems, especially such of differently operating voltages, shall be separated.

#### **D.14 Measures for limitation of the propagation of fire along cable- and wire bundles**

**D.14.1** All cables shall be so installed that the original flame-retardant properties of the individual cables are not impaired. This requirement can be considered to be fulfilled if:

- the bundled cables are individually flame-retardant and have been successfully passed the bundle fire test in accordance with IEC publication 60332-3 category A/F



- suitable measures have been taken during the installation, e.g. by providing of fire stops or application of flameproof coatings

**D.14.2** For cable bundles consisting of cables which have not been subjected to a bundle fire test, the following precautions shall be taken to limit the fire propagation:

**D.14.2.1** Fire stops shall be provided:

- a) at main- and emergency switchboards
- b) at cable entries to engine control rooms
- c) at central control panels and -consoles for the main propulsion plant and for important auxiliaries

**D.14.2.2** In closed- and semi-enclosed rooms, fire stops shall be provided at the following locations:

- at each entry- and exit point of cable runs in enclosed metallic installation shafts
- for open vertical cable runs, at least for every second deck, limited to a maximum interval of 6 m
- every 14 m for open horizontal cable runs

### **D.14.3 Exceptions**

Fire stops in accordance with [D.14.2.1](#) a) and c) can be omitted if the switchboards or consoles are installed in separate rooms and measures have already been taken at the cable entrances to these rooms, in cargo holds and in under-deck service passageways in the cargo zone. Fire stops shall be provided only for the boundaries of these rooms.

### **D.14.4 Version of fire stops**

The flame propagation of cables passing through fire stops shall fulfil the **SOLAS** requirements for B-O partitions.

Fire stops may, for example, be formed by existing partitions or by a steel plate (min. 3 mm in thickness) together with a B-O penetration in each case.

The steel plate shall be so formed that it extends around the cables as specified below:

- twice the maximum dimension of the cable run with vertically laid cables
- the maximum dimension of the cable run with horizontally laid cables

The steel plates, however, need not to be extended through upper covers, decks, bulkheads or trunk walls.

### **D.14.5 Application of flameproof coatings**

Instead of the fire stops prescribed in [D.14.4](#), installed cable bundles may be provided with (GL type approved) flameproof coatings as follows:

- on horizontal cable runs for every 14 m, a length of 1 m
- on vertical cable runs over the entire length

Other distances for the coatings may be approved after special testing.

### **D.14.6 Alternative methods**

Other methods which have been proved to be equivalent to the measures stated in [D.14.4](#) and [D.14.5](#) may be accepted.

### **D.14.7 Explanatory sketches**

Explanatory notes to the installation provisions described above are given in [Figs. 12.1](#) to [12.4](#).

## D.15 Application of fire-resistant cables

### D.15.1 Scope of installations

**D.15.1.1** Where cables specified in [Section 20, F.1.3](#) for services (see [D.15.1.3](#)) including their power supplies pass through high fire risk areas, and in addition for passenger ships, main vertical fire zones, other than those which they serve, they are to be so arranged that a fire in any of these areas or zones does not affect the operation of the service in any other area or zone. This may be achieved by either of the following measures:

- a) Cables being of a fire resistant type complying with IEC publication 60331-2 or 60331-21, 60331-23, 60331-25, or 60331-1 for cables of greater than 20 mm overall diameter, are installed and run continuous to keep the fire integrity within the high fire risk area, see [Fig. 12.5](#).
- b) At least two-loops/radial distributions run as widely apart as is practicable and so arranged that in the event of damage by fire at least one of the loops/radial distributions remains operational.

**D.15.1.2** Systems that are self monitoring, fail safe or duplicated with cable runs as widely separated as is practicable may be exempted provided their functionality can be maintained.

#### Notes

- a) *The definition for "high fire risk areas" is the following:*
  - *Machinery spaces as defined in Chap. II-2/ Reg. 3.30 of SOLAS, except spaces having little or no fire risk as defined by paragraphs (10) of Chap. II-2 / Reg. 9.2.2.3.2.2 of SOLAS. (Including the interpretations for tables 9.3, 9.4, 9.5, 9.6, 9.7 and 9.8 given in MSC/Circ.1120)*
  - *Spaces containing fuel treatment equipment and other highly flammable substances*
  - *Galley and Pantries containing cooking appliances*
  - *Laundry containing drying equipment*
  - *Spaces as defined in paragraphs (8), (12), and (14) of Chap. II-2 / Reg. 9.2.2.3.2.2 of SOLAS for ships carrying more than 36 passengers.*
- b) *Fire resistant type cables shall be easily distinguishable.*
- c) *For special cables, requirements in the following standards may be used:*  
*IEC60331-23: Procedures and requirements – Electric data cables*  
*IEC60331-25: Procedures and requirements – Optical fibre cables*

**D.15.1.3** Emergency services required to be operable under fire conditions on the cables include:

- fire and general alarm system
- fire extinguishing systems and fire extinguishing media release alarms
- fire detection system
- control and power systems to power operated fire doors and status indication for all fire doors
- control and power systems to power operated watertight doors and their status indication
- emergency lighting
- public address system
- low location lighting (see IACS UI SC135)
- emergency fire pump
- remote emergency stop / shutdown arrangements for systems which may support the propagation of fire and/or explosion

### D.15.2 Installation

For installation of fire-resistant cables the following shall be observed:

- The cables shall be arranged in such a way as to minimise the loss of operational availability as a result of a limited fire in any area.
- The cables shall be installed as straight as possible and with strict observance of special installation requirements, e.g. permitted bending radii.

## **E Requirements for Busbar Trunking Systems intended for the Electrical Supply of Distribution Panels and Single Consumers**

### **E.1 Scope**

The following listed additional requirements are valid for the design and the installation of busbar trunking systems, which are installed outside of switchboards and are intended for the supply of distribution boards or single consumers.

Busbar trunking systems shall not be installed in explosion endangered areas and on the open deck.

### **E.2 Components of the busbar trunking system**

A busbar trunking system consists of the following components:

- Electrical conductors including neutral and protective conductors, their insulation and the encasement of the busbar trunking system
- connecting elements
- separation units
- insulators and fixing elements
- arc barriers
- tap-off units
- bulkhead and deck penetrations
- protection devices

### **E.3 Requirements**

#### **E.3.1 Basic requirements**

The safety standard and availability of ship mains designed to include busbar trunking systems shall be at least equivalent to those of conventionally cables ship mains, even in case of failure.

Busbar trunking systems shall comply with the requirements of IEC publication 61439-1 and IEC publication 61439-6.

#### **E.3.2 Requirements for components**

##### **E.3.2.1 Degree of protection**

The design of the busbar trunking system shall comply with the following minimum degrees of protection:

- dry spaces, e.g. accommodation, IP 54
- wet spaces, e.g. engine rooms, IP 56

The operational readiness of the busbar trunking system shall be not impaired by condensed moisture. Where required means for automatic draining shall be provided.

Busbar trunking systems shall be protected against mechanical damage.

##### **E.3.2.2 Bulkhead and deck penetrations, fire protection**

The used materials shall be halogen-free and shall be flame-retardant according to IEC publication 60695-2.

The whole busbar trunking system shall meet with regard to the flame-spread the test requirements of IEC publication 60332-3, category A/F.

Bulkhead and deck penetrations for busbar trunking systems shall conform to categories laid down by **SOLAS** and shall not impair the mechanical strength and the watertightness of bulkheads and decks.

The propagation of smoke via the busbar trunking system shall be effectively prevented.

### **E.3.3 System requirements**

#### **E.3.3.1 System configuration**

The design of busbar trunking systems shall be such that in case of a single failure the supply to redundant essential equipment continues. Redundant essential equipment shall be supplied via separate busbar trunking systems. Common busbar systems for main and emergency supply are not permitted.

Where a busbar trunking system is arranged below the uppermost continuous deck, the vessel's manoeuvrability and the operation of all installations necessary for the main purpose of the vessel as well as the safety of the crew and passengers shall not be impaired in the event of one or more watertight compartments outside the engine room being flooded.

Where busbar trunking systems are led through several watertight sections, means for separation at the supply-side of the transitions shall be provided. The units for separation shall be approachable, marked for identification and secured against unauthorized uncovering.

#### **E.3.3.2 Protection devices**

Busbar trunking systems shall be protected against overload and short-circuit.

Switchgear of the busbar trunking system shall be arranged with regard to selectivity.

The propagation of electric arcs along the busbar trunking system shall be prevented by arc barriers or other means. If current limiting circuit breakers are used, those means are not required.

### **E.4 Tests**

#### **E.4.1 Aboard tests**

On the basis of approved documentation an aboard test of the completed installation shall be made. This includes the functional testing of the busbar trunking system and the check of settings for protection devices.

#### **E.4.2 Type-approval**

Busbar trunking systems are subject to mandatory type approval.

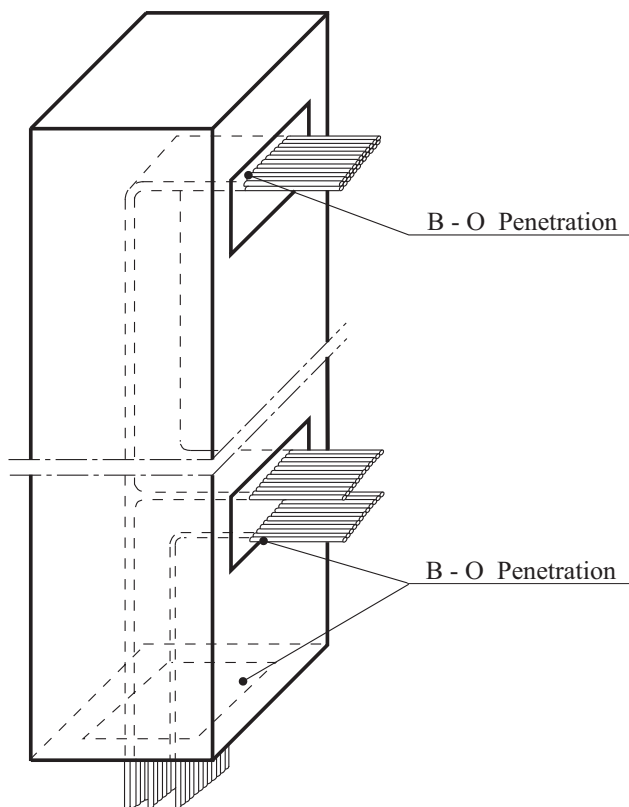

Fig. 12.1 Fire stops, all steel plates at least 3 mm thick

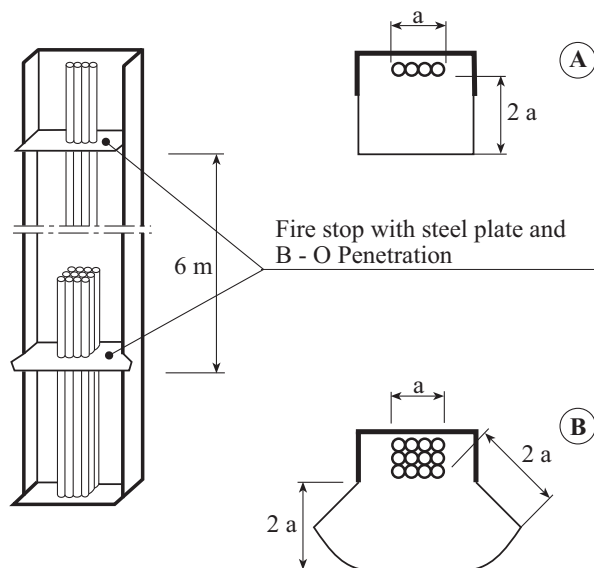
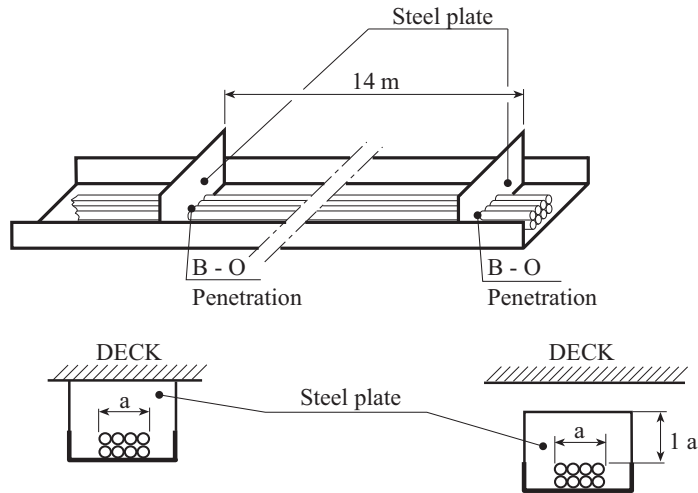
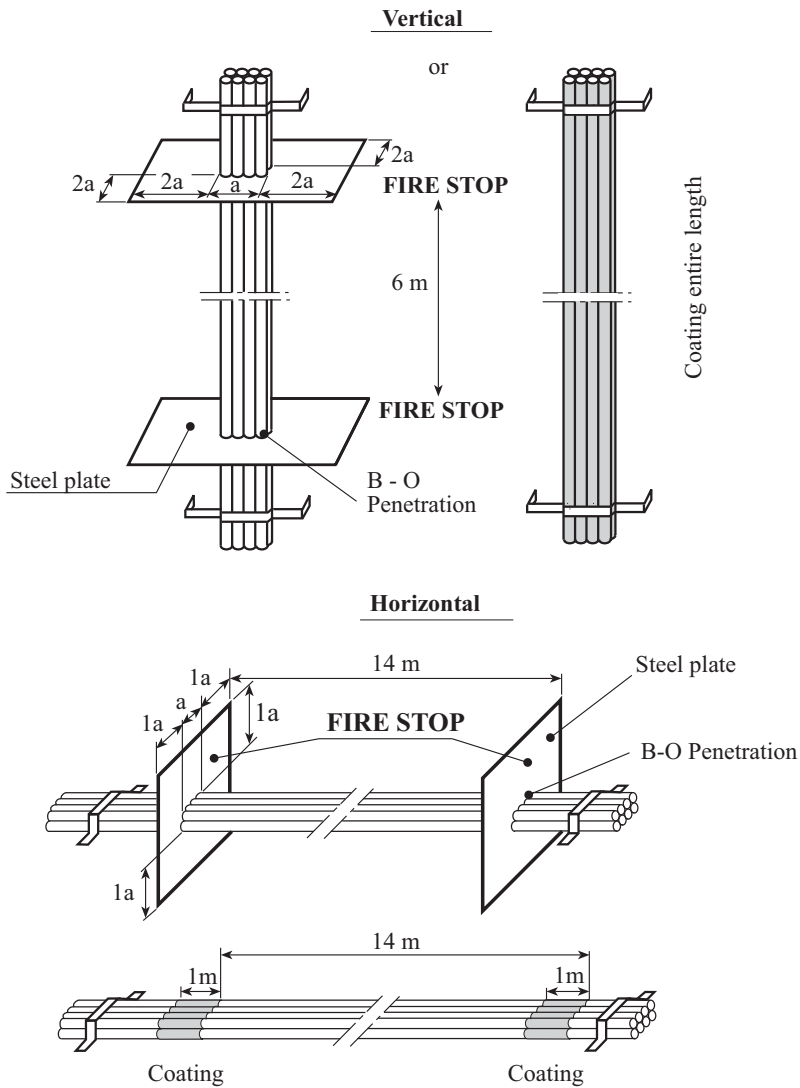

Fig. 12.2 Partly enclosed ducts, vertical



**Fig. 12.3 Partly enclosed ducts, horizontal**



**Fig. 12.4 Open cable runs**

Section 12 Cable Network

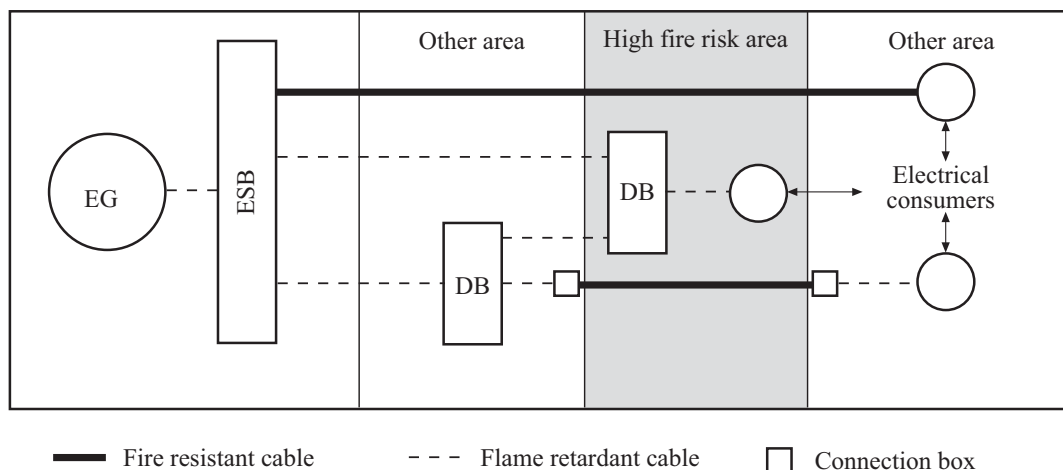

Fig. 12.5 Installation of fire resistant cables through high fire risk areas

Table 12.6 Current-carrying capacity of cables, max. permissible conductor operating temperature of 60 °C and 75 °C

Nominal cross-section		Current-carrying capacity based on a maximum conductor operating temperature of					
		60 °C			75 °C		
		S 1 cont. operation	S 2- 30 min	S 2- 60 min	S 1 cont. operation	S 2- 30 min	S 2- 60 min
mm <sup>2</sup>	AWG/MCM	A max.	A max.	A max.	A max.	A max.	A max.
<b>Single core cables</b>							
1.0	17	8	8	8	13	14	14
1.5	15	12	13	13	17	18	18
2.5	13	17	18	18	24	25	25
4	11	22	23	23	32	34	34
6	9	29	31	31	41	43	43
10	7	40	42	42	57	60	60
16	5	54	57	57	76	81	81
25	3	71	76	75	100	107	106
35	2	87	94	92	125	135	133
50	0	105	114	111	150	164	159
70	2/0	135	150	143	190	211	201
95	4/0	165	186	177	230	260	246
120	250	190	220	203	270	313	289
150	300	220	260	238	310	366	335
185	400	250	305	273	350	427	382
240	500	290	365	322	415	523	461
300	600	335	439	379	475	622	537
<b>2-core cables</b>							
1.0	17	7	7	7	11	12	12
1.5	15	10	11	11	14	15	15
2.5	13	14	15	15	20	21	21
4	11	19	21	20	27	29	29
6	9	25	27	27	35	38	37
10	7	34	38	36	48	53	51
16	5	46	52	49	65	73	70
25	3	60	71	65	85	101	92

**Table 12.6 Current-carrying capacity of cables, max. permissible conductor operating temperature of 60 °C and 75 °C (continued)**

Nominal cross-section		Current-carrying capacity based on a maximum conductor operating temperature of					
		60 °C			75 °C		
		S 1 cont. operation	S 2- 30 min	S 2- 60 min	S 1 cont. operation	S 2- 30 min	S 2- 60 min
mm <sup>2</sup>	AWG/MCM	A max.	A max.	A max.	A max.	A max.	A max.
<b>3- or 4-core cables</b>							
1.0	17	6	6	6	9	10	10
1.5	15	8	9	8	12	13	13
2.5	13	12	13	13	17	18	18
4	11	15	16	16	22	24	23
6	9	20	22	21	29	32	31
10	7	28	31	30	40	45	42
16	5	38	43	41	53	60	57
25	3	50	60	55	70	84	76
35	2	61	76	67	87	108	96
50	0	73	95	82	105	137	118
70	2/0	94	129	108	133	182	153
95	4/0	115	165	137	161	232	192
120	250	133	200	162	189	284	231
<b>Multi-core cables</b>							
5 × 1.5	5 × 15	7			10		
7 × 1.5	7 × 15	6			9		
10 × 1.5	10 × 15	6			8		
12 × 1.5	12 × 15	5			7		
14 × 1.5	14 × 15	5			7		
16 × 1.5	16 × 15	5			7		
19 × 1.5	19 × 15	4			6		
24 × 1.5	24 × 15	4			6		
AWG: American Wire Gauge MCM: Mille Circular Mil							



Section 12 Cable Network

**Table 12.7 Current-carrying capacity of cables, max. permissible conductor operating temperature of 80 °C and 85 °C**

Nominal cross-section		Current-carrying based on a maximum conductor operating temperature of					
		80 °C			85 °C		
		S 1 cont. operation	S 2- 30 min	S 2- 60 min	S 1 cont. operation	S 2- 30 min	S 2- 60 min
mm <sup>2</sup>	AWG/MCM	A max.	A max.	A max.	A max.	A max.	A max.
<b>Single-core cables</b>							
1.0	17	15	16	16	16	17	17
1.5	15	19	20	20	20	21	21
2.5	13	26	28	28	28	30	30
4	11	35	37	37	38	40	40
6	9	45	48	43	48	51	51
10	7	63	67	67	67	71	71
16	5	84	89	89	90	95	95
25	3	110	118	117	120	128	127
35	2	140	151	148	145	157	154
50	0	165	180	175	180	196	191
70	2/0	215	239	228	225	250	239
95	4/0	260	294	278	275	311	294
120	250	300	348	321	320	371	342
150	300	340	401	367	365	431	394
185	400	390	476	425	415	506	452
240	500	460	580	511	490	617	544
300	600	530	694	599	560	734	633
<b>2-core cables</b>							
1.0	17	13	13	13	14	14	14
1.5	15	16	17	17	17	18	18
2.5	13	22	24	23	24	26	25
4	11	30	32	32	32	35	34
6	9	38	41	40	41	45	43
10	7	53	59	56	57	63	60
16	5	71	80	76	76	86	81
25	3	93	111	100	102	121	110
<b>3- or 4-core cables</b>							
1.0	17	10	11	11	11	12	12
1.5	15	13	14	14	14	15	15
2.5	13	18	19	19	20	22	21
4	11	24	26	25	27	29	29
6	9	31	34	33	34	37	36
10	7	44	49	47	47	53	50
16	5	59	67	63	63	72	67
25	3	77	92	84	84	101	92
35	2	98	122	108	101	125	111
50	0	115	150	129	126	164	141
70	2/0	150	206	173	157	215	181
95	4/0	182	262	217	192	276	228
120	250	210	315	256	224	336	273
<b>Multi-core cables</b>							
5 × 1.5	5 × 15	11			12		
7 × 1.5	7 × 15	11			10		
10 × 1.5	10 × 15	9			9		
12 × 1.5	12 × 15	8			9		
14 × 1.5	14 × 15	8			8		
16 × 1.5	16 × 15	7			8		
19 × 1.5	19 × 15	7			7		
24 × 1.5	24 × 15	7			7		
AWG: American Wire Gauge MCM: Mille Circular Mil							

**Table 12.8 Current-carrying capacity of cables, max. permissible conductor operating temperature of 85 °C (JIS) \***

Nominal cross-section to JIS *	Current-carrying capacity based on a maximum conductor operating temperature of 85 °C		
	S 1 continuous operation	S 2 - 30 min	S 2 - 60 min
[mm <sup>2</sup> ]	A max.	A max.	A max.
<b>Single-core cables</b>			
1.25	18	19	19
2.0	25	26	26
3.5	35	37	37
5.5	46	49	49
8.0	59	63	63
14.0	83	88	88
22.0	110	117	117
30.0	135	144	143
38.0	155	167	164
50.0	185	202	196
60.0	205	228	217
80.0	245	277	262
100.0	285	331	305
125.0	325	384	351
150.0	365	445	398
200.0	440	554	488
250.0	505	662	571
<b>2-core cables</b>			
1.25	16	17	17
2.0	21	22	22
3.5	30	32	32
5.5	39	42	41
8.0	50	55	53
14.0	71	79	75
22.0	94	106	101
30.0	115	137	124
<b>3-core cables</b>			
1.25	13	14	14
2.0	17	18	18
3.5	25	27	27
5.5	32	35	34
8.0	41	45	43
14.0	58	65	61
22.0	77	88	82
30.0	94	113	102
38.0	110	136	121
50.0	130	169	146
60.0	145	199	167
80.0	175	252	208
100.0	200	300	244
<b>Multi-core cables</b>			
5 × 1.25	11		
7 × 1.25	10		
9 × 1.25	9		
12 × 1.25	8		
16 × 1.25	7		
19 × 1.25	6		
23 × 1.25	6		
27 × 1.25	6		
* Japanese Industrial Standard			

Section 12 Cable Network

**Table 12.9 Current-carrying capacity of cables, max. permissible conductor operating temperature of 90 °C and 95 °C**

Nominal cross-section		Current-carrying based on a maximum conductor operating temperature					
		90 °C			95 °C		
		S 1 cont. operation	S 2- 30 min	S 2- 60 min	S 1 cont. operation	S 2- 30 min	S 2- 60 min
mm <sup>2</sup>	AWG/MCM	A max.	A max.	A max.	A max.	A max.	A max.
<b>Single-core cables</b>							
1.0	17	18	19	19	20	21	21
1.5	15	23	24	24	24	25	25
2.5	13	40	43	43	32	34	34
4	11	51	54	54	42	45	45
6	9	52	55	55	55	58	58
10	7	72	77	77	75	80	80
16	5	96	102	102	100	106	106
25	3	127	135	134	135	144	143
35	2	157	170	167	165	178	175
50	0	196	214	208	200	218	212
70	2/0	242	269	257	255	283	270
95	4/0	293	331	314	310	350	332
120	250	339	390	362	360	410	385
150	300	389	459	420	410	484	443
185	400	444	541	484	470	573	512
<b>2-core cables</b>							
1.0	17				17	18	18
1.5	15	20	21	21	20	21	21
2.5	13	26	28	28	27	29	29
4	11	34	37	36	36	39	38
6	9	44	48	46	47	51	50
10	7	61	68	65	64	71	68
16	5	82	93	88	85	96	91
25	3	108	128	116	115	137	124
<b>3- or 4-core cables</b>							
1.0	17				14	15	15
1.5	15	16	17	17	17	18	18
2.5	13	21	23	22	22	24	23
4	11	28	30	30	29	32	31
6	9	36	39	38	38	42	40
10	7	50	56	53	52	58	55
16	5	67	77	72	70	80	75
25	3	89	107	97	94	113	102
35	2	110	136	121	115	143	127
50	0	137	178	153	140	182	157
70	2/0	169	232	195	178	244	205
95	4/0	205	295	244	217	312	258
120	250	237	356	289	252	378	307
<b>Multi-core cables</b>							
5 × 1.5	5 × 15				14		
7 × 1.5	7 × 15				13		
10 × 1.5	10 × 15				11		
12 × 1.5	12 × 15				10		
14 × 1.5	14 × 15				10		
16 × 1.5	16 × 15				9		
19 × 1.5	19 × 15				9		
24 × 1.5	24 × 15				8		
AWG: American Wire Gauge MCM: Mille Circular Mil							



## Section 13 Additional Rules for Electrical Main Propulsion Plants

A	General .....	13-1
B	Drives .....	13-2
C	Static Converter Installations .....	13-2
D	Control Stations .....	13-4
E	Ships' Mains .....	13-5
F	Control and Regulating .....	13-5
G	Protection of the Plant.....	13-6
H	Measuring, Indicating, Monitoring and Operating Equipment.....	13-7
I	Cables and Cable Installation .....	13-10
J	Construction Supervision, Testing and Trials .....	13-10
K	Additional Rules for Ships with redundant Propulsion Systems (RP1x%, RP2x% or RP3x%).....	13-12

### A General

**A.1** A ship has an electrical main propulsion plant if the main propulsion is produced by at least one electrical propulsion motor, or if this motor provides temporarily the entire propulsive power.

**A.2** If a propulsion plant has only one propulsion motor and the ship has no additional propulsion system which ensures sufficient propulsive power, then this plant shall be so structured that, following a malfunction in the static converter or in the regulation and control system, at least a limited propulsion capability remains.

**A.2.1** As the minimum requirement for an electrical main propulsion plant, the following requirements apply:

- At least two mutually independent static converters shall be provided, with mutually independent cooling systems, regulating systems, reference value inputs, actual-value acquisition, etc.
- The supply of the power circuits must be provided by separate cables from different sections of the propulsion switchboard.

In the case of single drives, two electrically isolated windings shall be provided for three-phase AC motors.

**A.3** Auxiliary propulsion plants are additional propulsion systems.

**A.4** The engines driving the generators for the electrical propulsion plant are main engines, the motors driving the propeller shaft or the thrusters are propulsion motors.

**A.5** If electrical main propulsion plants are supplied from the ship's general mains, the Rules in this Section apply also to the generators and the associated switchgear.

**A.6** The static converters shall be easily accessible for inspection, repair and maintenance.

**A.7** Equipment shall be provided to support the fault diagnosis process.

**A.8** IEC publication 60092-501: "Special features – Electric propulsion plant" shall be considered.

## B Drives

### B.1 Basis for dimensioning

**B.1.1** The electrical machinery and plants shall, in accordance with their service and operating conditions, be designed for short periods of overload and for the effect of manoeuvres and the state of sea.

**B.1.2** The lubrication of machinery and shafting shall be designed to be adequate for the entire speed range of rotation in both directions including towing.

**B.1.3** Each shaft shall be fitted with an adequately dimensioned locking device that permits towing of the ship, or the operation of other propulsion systems, without rotation of the locked, non-driven shaft.

The remaining drives may be operated at reduced power, provided that sufficient manoeuvring capability is ensured.

### B.2 Main engines

The main engines shall also conform to the requirements of the GL Rules for [Machinery Installations \(I-1-2\)](#), [Section 2](#).

**B.2.1** The diesel governors shall ensure safe operation under all running and manoeuvring conditions, this for both single operation and parallel operation.

**B.2.2** The response on different reduction alarms shall be agreed with GL.

### B.3 Propulsion motors

The propulsion motors shall also conform to the requirements of [Section 20, A](#).

**B.3.1** The effects of the harmonics of currents and voltages shall be taken into consideration for the design of the propulsion motors.

**B.3.2** The winding insulation shall be designed to withstand the overvoltages which may arise from manoeuvres, switching operations, converter operation and earth faults.

**B.3.3** Separately cooled machines shall be so dimensioned that, in case of failure of the separate cooling, limited operation is still possible. Versions deviating from this principle require the agreement of GL.

**B.3.3.1** It shall be possible to check the function of the cooling system by means of local temperature indicators (e.g. water: inlet and outlet; air: intake and discharge).

If it is not possible to install local, directly measuring thermometers, external indicators which are independent from other systems shall be provided.

It shall be ensured that water due to leakage or condensation is kept away from the windings.

**B.3.4** Electrical propulsion motors shall be able to withstand without damage a short circuit at their terminals and in the system under rated operating conditions until the protection devices respond.

**B.3.5** All stator winding ends shall be routed to terminals in the terminal box and to be connected only there.

## C Static Converter Installations

### C.1 General

**C.1.1** Power-electronic equipment shall also conform to the requirements of [Section 6](#).

**C.1.2** Static converters shall be designed for all operating and manoeuvring conditions including overload.

**C.1.3** For the design of the static converter cabinets, the requirements for main switchboards shall be applied as and where appropriate.

## **C.2 Converter assemblies**

**C.2.1** For separately cooled static converters, independent cooling systems shall be provided for each converter.

If static converters are separately cooled, it shall be possible to continue operation of the plant at reduced power in the event of failure of its cooling system.

Failure of the cooling system shall be signalled by an alarm.

The temperature of the converter cabinet as well as the temperature of the power semiconductors or of the heat sinks shall be monitored.

**C.2.2** If limited operation of liquid cooled static converters is not possible after failure of the separate cooling system, then two coolant pumps with the corresponding stand-by circuits shall be provided.

**C.2.3** For liquid-cooled static converters, the following monitoring arrangements shall be provided in addition:

- coolant flow or differential pressure
- coolant leakage
- coolant pressure
- coolant conductivity
- coolant temperature
- failure of the coolant pumps/fans
- stand-by alarm of the coolant pumps

**C.2.4** For the components of the DC link, the following monitoring arrangements shall be provided:

- temperature monitoring of the DC link reactor
- undervoltage and overvoltage monitoring
- current monitoring
- short-circuit monitoring
- current monitoring of the braking resistor

**C.2.5** The input supply shall be provided with the following monitoring arrangements:

- failure of the supply
- overvoltage
- undervoltage
- underfrequency

These values shall be coordinated with the mains supply protection and the generator protection.

**C.2.6** The following internal monitoring equipment shall be provided for the static converter:

- semiconductor failure
- semiconductor fuse failure
- firing pulse error
- control deviation
- system error of the control system
- actual speed / rotor position encoder failure

- current actual value failure
- faulty setpoint input
- power supply failure
- failure in the bus system

### **C.3 Main and exciter power circuits**

**C.3.1** The circuits for main power supply and exciters shall be supplied directly from the switchboard and shall be separate for each motor respectively each winding system.

The exciter shall be supplied from the dedicated section of the main- or propulsion switchboard supplying the main circuit. This applies also to other auxiliary systems.

DC motors and separately excited machines designed as a single drive shall be fitted with two exciter devices.

**C.3.2** The main circuits shall be supplied through remotely actuated circuit-breakers.

**C.3.3** In the supply of exciter circuits, only short-circuit protection shall be provided.

**C.3.4** In the event of failure of the excitation, the corresponding power component shall also be switched off. Failure of the excitation system shall be signalled by an alarm.

### **C.4 Installation according to IEC 60533**

**C.4.1** Plants that do not meet the requirements set out in the GL Guidelines [Test Requirements for Electrical / Electronic Equipment and Systems \(VI-7-2\)](#) relating to the stray radiation from the housing and/or the conducted interference shall be installed in separate spaces.

**C.4.1.1** The supply lines, and the cables to the propulsion motor, shall be run separately from each other and from other cables.

**C.4.1.2** Such plants shall be supplied via transformers.

### **C.5 Filter circuits**

**C.5.1** If filter circuits are used to reduce the harmonics, these circuits must be protected against overload and short circuit.

**C.5.2** Filters shall be monitored for failure.

**C.5.3** The operating instructions shall document which propulsion settings and generator combinations are admissible after failure of one or all of the filters. This shall be verified by means of a THD measurement.

**C.5.4** Filters shall function properly in all propulsion settings and grid configurations and shall not lead to increases in voltage or current. This shall be verified through measurements during the sea trial.

## **D Control Stations**

Control equipment shall conform to the GL Rules for [Automation \(I-1-4\)](#) as and where appropriate. Additionally, the following Rules apply:

**D.1** Where the propulsion main control station is located on the bridge, provisions shall be made for the control of the propulsion plant also from the engine room and control room.

**D.2** For any arbitrary fault of the automatic remote control and the propulsion main control stations, local operation shall be possible from the local control station.



**D.2.1** Changeover shall be possible within a reasonably short time. The local control station shall receive the highest priority, and it shall be possible to select this control station locally.

This control station shall be connected directly to the corresponding static converter.

It shall be ensured that control is only possible from one control station at any time. Transfer of command from one control station to another shall only be possible when the respective control levers are in the same position and when a signal to accept the transfer is given from the selected control station.

The loss of control at the concerned control station is to be signalled optically and audibly.

**D.2.2** Ships with a restricted service area may, with the consent of GL, have only one propulsion main control station on the bridge and a local control station.

**D.2.3** It shall be possible to acknowledge all malfunctions at the local control station.

**D.2.4** At the propulsion main control station, it shall be possible to acknowledge at least all those malfunctions that are caused by the auxiliary services or by the supply network. After a black-out, it shall be possible to restart the propulsion at the propulsion main control station.

**D.3** The propulsion main control stations on the bridge and in the engine control room as well as the local control station shall be provided with an emergency stop device that is independent of the main control system. The emergency stop device in the engine control room shall be provided even if only control positions according to [D.2.2](#) exists.

**D.4** All operating functions shall be made logical and simple, to prevent maloperation. The operating equipment shall be clearly arranged and marked accordingly.

**D.5** A malfunction in a system for synchronising or in a position equalisation device for controlling the operating levers of several control stations shall not result in the failure of the remote control from the main control position.

## **E Ships' Mains**

**E.1** It shall be possible to connect and disconnect generators without interrupting the propeller drive.

**E.2** If a power management system is used, the automatic stop of main engines during manoeuvring shall be prevented.

**E.2.1** During estuary operation, each main busbar section shall be supplied by at least one generating set.

### **E.3 Propulsion switchboards**

The propulsion switchboard mainly distributes the energy to the propulsion system.

**E.3.1** If the total installed power of the main generator exceeds 3 MW, the propulsion switchboard shall be provided with a circuit-breaker for sectionalising the plant.

**E.3.2** Propulsion switchboards shall meet the requirements for main switchboards as and where appropriate.

## **F Control and Regulating**

Generally the control and regulating functions of the propulsion plant shall be completely independent of other systems. In normal operation computers and bus systems shall be permanently assigned to the

corresponding drive train. The failure of other control and monitoring equipment shall not lead to malfunctions in the propulsion plant.

If alarms are passed on to the machinery alarm system by means of collective alarms, it shall be considered that each additional new single alarm will reannunciate this collective alarm; see also [Section 9, B](#) and the GL Rules for [Automation \(I-1-4\)](#).

**F.1** An automatic power limitation and reduction of the propulsion plant shall ensure that the ship mains and propulsion network are not loaded inadmissibly.

**F.2** In the event of overcurrent, undervoltage, underfrequency, reverse power and overload, the propulsion shall be limited or reduced accordingly.

**F.3** Upon failure of a generator or a bus tie breaker, the resulting load surge shall be limited to the admissible values by the drives.

**F.4** The reverse power applied during reversing or speed-reducing manoeuvres shall be limited to the acceptable maximum values.

## **G Protection of the Plant**

### **G.1 General**

**G.1.1** Automatic tripping of the propulsion plant, such that it impairs the ship's manoeuvring capability, shall be limited to such malfunctions which would result in serious damage within the plant.

**G.1.2** The actuation of protection, reducing and alarm devices shall be indicated optically and audibly. The alarm condition shall remain recognisable even after switching off. A limitation of the running-up of the propulsion plant that is caused by generators reaching their maximum output should not be signalled as an alarm.

**G.1.3** The protection concept for the propulsion motor shall be described and agreed with GL.

**G.1.4** The settings of the protection devices for the generators, transformers and propulsion motors shall be coordinated with the settings of the power management system and those of the propulsion plant's converters. Any protection devices in the exciter circuits shall be deactivated or adjusted so that they respond subsequently.

**G.2** Protection devices shall be set to such values that they do not respond to overload occurring under normal service condition, e.g. while manoeuvring or in heavy seas.

**G.3** Defects in reducing and stopping devices shall not impair the limited propulsion capability in accordance with [A.2](#).

**G.4** In the event of failure of an actual or reference value, it shall be ensured that the propeller speed does not increase unacceptably, that the propulsion is not reversed, or that dangerous operating conditions can arise. The same applies to failure of the power supply for the control and regulating functions.

**G.5** The following additional protection equipment shall be provided:

- Where drives can be mechanically blocked in an uncontrolled manner, they shall be provided with monitoring equipment which prevents damage to the plant.
- overspeed protection
- protection against overcurrent and short circuit
- earth fault monitoring of stator and exciter windings

- protection device which detects internal faults of the motor (e.g. differential protection) for propulsion motors with an output of more than 1500 kW
- Following an internal fault in the motor or a short circuit in the output circuit, various measures may be necessary, depending on the location of the damage and the motor type. Error indication shall make it possible to identify the damaged parts of the plant. The feeder breakers and the disconnectors shall open automatically, insofar as they serve to limit the damage.

## **G.6 Permanently excited motors**

**G.6.1** For Permanently excited motors and motors with several stator windings, a disconnector shall be arranged between the motor terminals and the static converter.

**G.6.2** In the case of a fault below the disconnector of permanently excited motors, the ship shall be stopped as soon as possible and the corresponding shaft shall be locked. The corresponding alarm shall be provided at the control station. The installation shall be so designed that it is able to carry the short-circuit current of the motor for the stopping time. The disconnector shall have a corresponding switching capacity. In the event of faults in the output circuit of the static converter, this disconnector shall open automatically.

## **G.7 Separately excited motors**

**G.7.1** For separately excited motors the disconnectors in the main circuit shall open and the exciter devices shall be switched off in the event of faults in the output circuit.

## **G.8 Asynchronous motors**

**G.8.1** For asynchronous motors, it is sufficient to switch off the static converter and, if applicable, to open disconnecting devices for single windings.

**G.9** The transformers of propulsion plants shall be protected against over current and short circuit. Medium-voltage transformers of propulsion plants shall be equipped with an earthed shield winding. Propulsion transformers shall be monitored for over temperature. Propulsion transformers with an output of more than 1500 kVA shall be equipped with differential protection.

# **H Measuring, Indicating, Monitoring and Operating Equipment**

Faults in measuring, indicating, monitoring and operating equipment shall not cause any failure of the control and regulating functions.

## **H.1 Measuring equipment and indicators**

Main propulsion plants shall be provided with at least the following measuring equipment and indicators at control stations:

### **H.1.1 At a local control station:**

- ammeter and voltmeter for each supply and each load component
- ammeter and voltmeter for each exciter circuit
- revolution indicator for each shaft
- pitch indicator for plants with variable-pitch propellers
- indication of the generators used for propulsion or the reserve power that is still available
- on/off pushbuttons for each static converter
- on/off signals for each static converter
- selected static converter
- plant ready for switching on

- plant ready for operation
- plant disturbance
- control from engine control room
- control from the bridge
- control from the local control station
- reduced power and pushbutton “Override reduction” or “request for reduction”
- System-dependent alarms

#### **H.1.2 At the propulsion main control station in the engine control room:**

- power meter
- revolution indicator for each shaft
- pitch indicator for plants with variable-pitch propellers
- indication of the generators used for propulsion or the reserve power that is still available
- on/off pushbuttons for each static converter
- on/off signals for each static converter
- plant ready for switching on
- plant ready for operation
- plant disturbance
- reduced power and pushbutton “Override reduction” or “request for reduction”
- control from engine control room
- control from the bridge
- control from the local control station
- indication of the generators used for propulsion
- Changeover switch for port, estuary and sea operation
- System-dependent alarms

#### **H.1.3 Propulsion main control station on the bridge:**

- revolution indicator for each shaft
- pitch indicator for plants with variable-pitch propellers
- load indication of the generators used for propulsion or indication of the available power reserve
- on/off pushbuttons for each static converter
- on/off signals for each static converter
- plant ready for switching on
- plant ready for operation
- plant disturbance
- reduced power and pushbutton “Override reduction” or “request for reduction”
- control from engine control room
- control from the bridge
- control from the local control station
- System-dependent alarms

### **H.2 Monitoring equipment**

The actuation of the following monitoring equipment shall be signalled optically and audibly:

**H.2.1** Monitoring of the ventilators and temperatures of the cooling air for forced ventilation of machines and transformers.

**H.2.2** Monitoring of the flow rate and leakage of coolants for machines and transformers with closed cooling systems.

In the secondary cycle, at least the inlet temperature shall be registered. The separate cooling system shall be monitored for failure.

**H.2.3** For generators above 500 kVA and for motors and transformers, winding-temperature monitoring shall be provided.

**H.2.4** Bearing-temperature monitoring shall be provided for generators above 1500 kVA and for propulsion motors. A thermometer shall be installed locally for monitoring purposes. If the bearings are inaccessible, the temperature measurement system shall be designed to provide redundancy.

**H.2.5** Bearings with external lubrication shall be monitored for adequate lubrication under all operating conditions (e.g. pressure, flowrate, filling level).

The oil temperature shall be monitored.

A sight glass shall be provided for manual inspection. If the bearings are inaccessible, the lubrication monitoring system shall be designed to provide redundancy.

See also [Section 20, A.1.5](#).

**H.2.6** Both end positions of the shaft locking device (locked and released) shall be monitored. An alarm shall be triggered if the locking device is in an inadmissible position.

**H.2.7** In the case isolated networks or subnetworks, the insulation resistance shall be monitored.

### **H.3 Alarm coordination**

Generally a pre-alarm should be triggered, wherever possible, before shut down or reduction of the propulsion plant.

### **H.4 Start Blocking**

The start-up process of the propulsion plant shall be interlocked that starting is impossible if existing malfunctions would trigger a shutdown or if the start-up process itself would cause damage to the propulsion plant.

#### **H.4.1 Start-Blockings:**

- shaft locking device not released
- no cooling of static converter (overridable)
- no cooling of propulsion motor (overridable)
- no cooling of propulsion transformer (overridable)
- malfunction in exciter device
- malfunction in static converter
- converter control: shutdown activated
- propulsion switchboard switch-off active
- emergency stop actuated
- setpoint not equal to zero
- bearings: lubrication oil pressure too low
- conductivity of the cooling medium too high
- protection triggered
- circuit breaker malfunction
- missing enabling signal from variable-pitch propeller

**H.4.2** The pilot light “plant ready for switching on” may only be activated when all the prerequisites for start-up have been met.

**H.4.3** The pilot light “plant ready for operation” may only be activated if the propulsion plant would respond to set point setting.

## I Cables and Cable Installation

The cable network for electrical propulsion plants shall comply with the requirements of [Section 12](#).

If there is more than one propulsion unit, the cables of any one unit shall, as far as is practicable, be run over their entire length separately from the cables of the other units.

## J Construction Supervision, Testing and Trials

### J.1 Supervision during construction

Propulsion motors, generators, static converters and switchgear as part of the main propulsion plant are subject to supervision during construction by GL.

To allow supervision during construction, a quality assurance plan shall be submitted to GL.

The quality assurance plan shall contain the planned internal receiving, in-process and final inspections/tests, together with the relevant test instructions and the planned test records. The hold points with participation of GL will be determined on the basis of the quality assurance plan.

### J.2 Testing and the manufacturer’s works

The following additional tests shall be carried out:

**J.2.1** Tests of machines, static converters, switchgear, equipment and cables shall be carried out at the manufacturer’s works in accordance with [Section 20](#) and [J.21](#).

#### J.2.1.1 Testing of the static converters

**J.2.1.1.1** These tests shall meet the requirements of [Section 6](#) as and where appropriate. All alarms of the categories “Stop” and “Reduction” shall be documented with their limit values and tested. In the case of type-approved static converters, this is only necessary for the project-specific parameters.

**J.2.1.1.2** For type-approved static converters, the function of the general alarms shall be verified by spot checks. For static converters that are not type-approved, a complete test is required for the first converter of each series.

**J.2.1.1.3** Faults such as the failure of reference and actual value signals, power supply failure, ventilator failure, inadequate pressure and leakage of coolant, failure of miniature circuit-breakers, communication error etc. shall be listed together with their effects on the system and shall then be tested.

**J.2.1.1.4** The scope of tests for the first static converter of a series and for the subsequent converters shall be agreed with GL in each case.

#### J.2.1.2 Testing of the propulsion switchboard

A complete test of the protection devices, interlocks, etc. shall be carried out in accordance with the test requirements for main switchboards.

#### J.2.1.3 Testing of the remote control

For the first vessel of a series the remote control shall be set up with all control stations and tested.

#### **J.2.1.4 Testing of the transformers**

A complete type and routine test shall be carried out according to IEC publication 60076 or verification thereof submitted. For the temperature-rise test, the effect of the harmonics shall be considered; see [Section 20, B](#).

#### **J.2.1.5 Testing of the motors**

A complete type and routine test shall be carried out according to IEC publication 60034. For the temperature-rise test, the effect of the harmonics shall be considered; see [Section 20, A](#).

#### **J.2.1.6 Testing the power management system**

The power management systems shall be subject to a functional test (software FAT) in the manufacturer's works. Joint testing with the propulsion switchboard is recommended.

A test specification shall be defined and agreed with GL.

#### **J.2.2 Testing of the shaft material for generators and propulsion motors**

Proof of compliance with the GL Rules for [Principles and Test Procedures \(II-1-1\)](#) and [Steel and Iron Materials \(II-1-2\)](#) shall be provided by means of a shaft material test as for ship's shafting.

**J.2.3** The testing of other important forgings and castings for electrical main propulsion plants, e.g. rotors and pole shoe bolts, shall be agreed with GL.

**J.2.4** GL reserves the right to request additional tests.

#### **J.3 Tests after installation on board**

Newly-constructed or enlarged plants require testing and trials on board.

The scope of the trials shall be agreed with GL.

##### **J.3.1 Dock trial**

Functioning of the propulsion plant shall be proved by a dock trial before sea trials.

At least the following trials/measurements shall be carried out in the presence of a GL Surveyor:

- start-up, loading and unloading of the main and propulsion motors in accordance with the design
- of the plant and a check of regulation, control and switchgear as far as possible.
- verification of propeller speed variation and all associated equipment
- verification of protection, monitoring and indicating/alarm equipment including the interlocks for proper function
- verification of the reannouncement of collective alarms
- verification of the insulation condition of the main propulsion circuits
- for testing the ship mains, the main engines and the propulsion plant, a trial with a zero-thrust propeller or comparable equipment is recommended.

##### **J.3.2 Sea trial**

The trial programme shall at least include:

**J.3.2.1** Continuous operation of the ship at full propulsion load until the entire propulsion plant has reached steady-state temperatures.

The trials shall be carried out at rated engine speed and with an unchanged closed loop controls setting:

- at least 4 hours at 100 % power output (rated power), and at least 2 hours at the continuous power output normally used at sea.
- 10 minutes with the propeller running astern during the dock trial or during the sea trial at a minimum speed of at least 70 % of the rated propeller speed.

**J.3.2.2** Reversal of the plant out of the steady-state condition from full power ahead to full power astern and maintaining of this setting at least until the ship has lost all speed. Characteristic values, such as speed, system currents and voltages, and the load sharing of the generators, shall be recorded. If necessary, oscillograms shall be made.

**J.3.2.3** Performance of manoeuvres typically occurring in estuary trading (see GL [Guidelines for Sea Trials of Motor Vessels \(VI-11-3\)](#)).

**J.3.2.4** Checking of the machinery and plant in all operating conditions.

**J.3.2.5** Checking of the grid quality in the ship's propulsion network and mains:

- measurement at various propulsion speeds in normal operation.
- measurements with which the most unfavourable mains and propulsion plant configuration is determined.
- measurement at various propulsion speeds in most unfavourable mains and propulsion plant configuration
- Repeat measurement without THD filter as far as possible; see also [C.5.3](#).

The measurement results shall be recorded.

**J.3.2.6** Upon completion of the sea trial, a visual inspection of the components of the propulsion plant shall be performed. The insulation resistances of the propulsion transformers, propulsion motors and generators shall be determined and recorded.

## **K Additional Rules for Ships with redundant Propulsion Systems (RP1x%, RP2x% or RP3x%)**

See the GL Rules for [Redundant Propulsion and Steering Systems \(I-1-14\)](#).



## Section 14 Additional Rules for Passenger Vessels

A	General .....	14-1
B	Installation of Electrical Equipment.....	14-1
C	Electrical Power Supply Systems .....	14-2
D	Control-, Monitoring- and Ship's Safety Systems .....	14-4
E	Lighting.....	14-10
F	Cable Network .....	14-12

### A General

#### A.1 Scope

The general provisions of the GL Rules for Electrical Installations (I-1-3) also apply, as and where appropriate, to passenger vessels, except where more particular requirements are laid down in this Section.

#### A.2 References to other GL Rules

##### A.2.1 [Hull Structures \(I-1-1\)](#)

##### A.2.2 [Machinery Installations \(I-1-2\)](#)

#### A.3 References to international Regulations

**A.3.1** Passenger ships shall have on board a safety centre complying with the requirements of **SOLAS** II-2, Reg. 23 and MSC.1/Circ.1368.

**A.3.2** Passenger vessels having a length of 120 m or more or having three or more main vertical fire zones shall also comply with **SOLAS** II-1, Reg. 8, 8-1 and Reg. II-2, 21 and 22 <sup>1</sup>.

### B Installation of Electrical Equipment

**B.1** Attention is drawn to special provisions for structural fire protection for control stations. Control stations are e.g:

- location of the emergency source of electrical power
- bridge and chart room
- radio room
- main fire alarm and fire fighting station
- engine control room if located outside the engine room
- rooms in which central stations for general emergency alarm and loudspeaker systems (PA-systems) for emergency announcements are located

**B.2** Switch- and distribution boards in the passenger area shall not be accessible to passengers.

---

<sup>1</sup> Applicable to passenger vessels with keellaying on or after 1 July 2010.

## C Electrical Power Supply Systems

### C.1 Emergency electrical power supply

**C.1.1** An independent emergency source of electrical power shall be provided.

**C.1.2** The emergency source of electrical power shall be capable of simultaneously supplying at least the following equipment (if its operation depends on a source of electrical power) for the duration mentioned below, taking starting currents into account:

#### C.1.2.1 Emergency illumination for 36 hours

- a) at all launching stations for survival appliances on deck and along the outside of the hull
- b) in all passageways of the service- and accommodation area, on stairs and at exits and in passenger-lift cars
- c) in the machinery rooms and main-generator stations, including their control positions
- d) at all control stations, engine control rooms, on the bridge and each main- and emergency switch-board
- e) at all storage places for fireman's outfit
- f) in the steering gear compartment and the CO<sub>2</sub> room
- g) at the fire pumps listed in [C.1.2.4](#), the sprinkler pump and the emergency bilge pump, and at the starting-positions for their motors

#### C.1.2.2 For 36 hours

- a) the navigation lights and any other signalling lights required in accordance with the "International Regulations for Preventing Collisions at Sea"
- b) the in **SOLAS IV** required "VHF radio installation" and, if necessary the "MF radio installation" and the "ship earth station" and the "MF/HF radio installation"

#### C.1.2.3 For 36 hours

- a) all internal alarm systems and information equipment required in an emergency
- b) all ship navigation devices, which are required in **SOLAS V/12**
- c) the fire detection and fire alarm system and the system for operating and monitoring the fire doors
- d) devices for the intermittent operation of the daylight-signalling-lamp, the ship's siren, the manually operated fire alarm call points and all internal signals required in an emergency, such as General Emergency Alarm, CO<sub>2</sub>-alarm

if these facilities cannot be supplied independently from an emergency storage battery for the duration of 36 hours.

#### C.1.2.4 For 36 hours

- a) the stipulated emergency fire pumps
- b) the automatic sprinkler pump
- c) the emergency bilge pump and all the devices necessary for the operation of electrically-powered remotely controlled drainage valves
- d) the auxiliary equipment for the emergency diesel generator

**C.1.2.5** During the period stipulated by [Section 7, A.4](#), the steering gear if an emergency supply is obligatory, and the rudder angle indicator.

**C.1.2.6** For 3 hours on Ro-Ro passenger vessels the supplementary emergency illumination with self-contained luminaires, see [Section 16](#).

**C.1.2.7** For one hour the electric operated Low-Location Lighting (LLL system).

**C.1.2.8** For half an hour

- a) all watertight doors which in accordance with the GL Rules for [Machinery Installations \(I-1-2\)](#) shall be power-operated, their controls and the stipulated indicating and warning devices in accordance with [Section 7, D](#) (see also [C.1.4.2 b](#))
- b) the emergency equipment which brings the passenger lift cars to the next exit point for reasons of escape. If there are several passenger lift cars, they may in an emergency be brought to the exit point successive.

**C.1.3** For a ship which regularly makes voyages of limited duration, the national authorities may approve a shorter period than the 36 hours stipulated in [C.1.2.1](#) to [C.1.2.4](#), but not less than 12 hours, if in their opinion this ensures an adequate level of safety.

**C.1.4** The emergency source of electrical power for passenger ships may be either a generator set with a transitional source of emergency electrical power or a storage battery.

**C.1.4.1** If the emergency source of electrical power is a generator set it shall be powered by a suitable prime mover with its own independent fuel supply in accordance with the GL Rules for [Machinery Installations \(I-1-2\)](#), [Section 10, B](#) and an independent cooling system. The set shall start automatically if the main power supply fails. Supply to the consumers listed under [C.1.2](#) shall be taken over automatically by the emergency set. The emergency electrical supply provisions shall be such that the rated load capacity is assured as quickly as possible but not later than 45 seconds after failure of the main power supply.

**C.1.4.2** The transitional emergency source of electrical power shall be a storage battery which in the case of failure of the main and emergency power supplies immediately supplies the consumers listed below, until the emergency generator set described under [C.1.4.1](#) is operative and connected.

Its capacity shall be so rated that it is capable, without recharging to supply the consumers for the period as specified below. During this period its terminal voltage shall remain within  $\pm 12\%$  of the rated value.

The following consumers are to be taken into account, insofar as they depend on an electrical power source for their operation:

- a) for half an hour the lighting stipulated under [C.1.2.1](#) and [C.1.2.2 a](#)), lanterns and lights and all equipment stipulated under [C.1.2.3 a](#)), [C.1.2.3 c](#)) and [C.1.2.3 d](#)) insofar as these are not supplied independently by their own emergency storage battery during the stipulated period
- b) power for closing the watertight doors without a requirement for simultaneous closure of all doors and for their indicating devices and warning signals, as stipulated under [C.1.2.8 a](#))

**C.1.4.3** If the emergency source of electrical power is a storage battery it shall be capable in the event of failure of the main electrical power supply to take over automatically and immediately the supply to the consumers listed under [C.1.2](#) and of supplying them without a recharging for the stipulated period. During this period its terminal voltage shall remain within  $\pm 12\%$  of the rated value.

**C.1.4.4** An indication of inadmissible battery discharge (emergency source of electrical power and transitional emergency electrical power source) shall be provided at the main switchboard or in the engine control room.

**C.2 Power systems**

**C.2.1 Steering gear**

On all passenger ships, full steering power shall be available even if one power unit is inoperative.

**C.2.2 Pressure water spraying systems (Sprinkler)**

If an automatic electrically powered fire extinguishing and alarm system is provided, pumps and compressors shall each be supplied via direct cables from the main switchboard and from the emergency switchboard. Near the sprinkler system operating position is a changeover switch required which automatically switches to supply from the emergency switchboard if the main supply fails.

### **C.2.3 Fire pumps**

On passenger vessels of  $\geq 1000$  GRT resp. BRZ, one of the fire pumps shall start up automatically if the fire main pressure drops.

### **C.2.4 Fans**

**C.2.4.1** All motor fans, except for engine rooms and cargo space ventilation, shall be fitted with switching devices which are so arranged that all of the fans can optionally be stopped and switched on from two control positions located as far apart as possible. One of these positions shall be located on the bridge.

The switchgear provided for engine room power operated ventilators shall be controlled from two positions of which one shall be outside the engine room area.

Power-operated cargo room fans shall be capable of being switched off from a safe control position outside the spaces in question.

**C.2.4.2** The galley supply- and exhaust fans shall additionally be capable of being stopped from a control position near the access-door to the galley.

### **C.2.5 Bilge pumps**

**C.2.5.1** See also the GL Rules for [Machinery Installations \(I-1-2\), Section 11](#).

**C.2.5.2** If submerged bilge pumps are electrically driven, the cables from a position above the bulkhead deck to the motors shall be laid in one continuous length.

All electrical equipment in this area used for this purpose shall remain operative if the room is flooded to bulkhead-deck level.

**C.2.5.3** A fixed installed submerged bilge pump shall be capable of being started from a position above the bulkhead deck.

If additionally a local starting device for the motor is provided, all control cables to this device shall be disconnected from a position near the starter above the bulkhead deck.

### **C.2.6 Cross-flooding arrangements**

Where closing devices are installed in cross-flooding arrangements, they shall be capable to be operated from the bridge or from a central position located above the bulkhead deck (see also the GL Rules for [Hull Structures \(I-1-1\), Section 26, J](#) and [Machinery Installations \(I-1-2\), Section 11, P](#) and [Section 7a, H](#)).

## **D Control-, Monitoring- and Ship's Safety Systems**

### **D.1 Interior communication systems**

#### **D.1.1 Voice communication for an emergency**

**D.1.1.1** A two-way voice communication shall be provided which permits the transmission of commands between strategically important positions, quarter of assembly, the emergency control positions, the muster stations and the launching positions of the lifesaving appliances.

**D.1.1.2** This system may comprise portable or fixed equipment and shall remain operable even after failure of the main electrical power supply.

**D.1.1.3** For portable systems at least 3 portable VHF transceiver shall be provided.

## **D.1.2 Public address system (PA systems)**

### **D.1.2.1 General**

The public address system shall enable simultaneous broadcast of messages to all spaces where crew members and/or passengers are normally present. This includes spaces where passengers or crew members assemble in case of emergency, i.e. muster stations.

It shall be possible to address crew accommodation and working spaces separately from passenger spaces.

The broadcast shall be possible from the navigation bridge, and at least one other location on board (i.e. muster station, boat embarking station).

By the broadcast from the navigation bridge other signals which can be broadcasted on this system shall be interrupted.

Additional to [Section 9, D.2.1](#) the public address system shall also cover the open deck.

If the public address system is used for the transmission of the general alarm, [D.2](#) shall be observed additionally.

Functional proofs have to be provided at environmental conditions and EMC requirements according to the GL Guidelines for [Test Requirements for Electrical / Electronic Equipment and Systems \(VI-7-2\)](#).

#### **Note**

*With regard to EMC reference is made to IEC publications 60533 and 60945.*

### **D.1.2.2 System requirements**

Voice communication stations of the system necessary for emergency shall fulfill the following requirements:

1. Controls for emergency functions shall be clearly indicated.
2. Controls shall be safe guarded against unauthorized use.
3. If operated any other broadcasts of other systems or programmes shall be automatically interrupted.
4. Operation from the control stations including the bridge shall automatically override all volume controls and on/off controls so that the required volume for the emergency mode is achieved in all spaces.

All areas of each fire zone shall be served by at least two independent loops. The supply shall be done by at least two independent amplifiers so that in case of failure of one amplifier or loop the broadcast is possible with reduced volume.

Amplifiers with multiple outputs may serve the loop of another fire zone provided the short circuit of one output does not effect the other outputs.

### **D.1.2.3 Protection of loudspeaker loops**

Short circuits in loudspeakers shall not cause the loss of the complete loop.

This requirement is fulfilled, e.g. if each loudspeaker is supplied by an own transformer and a short circuit of the secondary coil does not effect the operation of the remaining loudspeakers.

### **D.1.2.4 Supply of the amplifiers**

Each amplifier shall be powered by an own power unit. The supply shall be provided from the main source of power, the emergency source of power and the transitional emergency source of power.

### **D.1.2.5 Installation**

The panels of a PA system shall be installed in a control station.

The system shall be arranged to minimize the effect of a single failure, e.g. by the use of multiple amplifiers with segregated cable routes.

The cables shall, as far as practicable, be routed clear of galleys, laundries, machinery spaces of category A and their walls and other areas with a high fire risk. Exempted are cables, which are serving those

spaces. Where practicable, all the cables shall be run in such a way that they will not be impaired by the effects of a fire in an adjacent space separated by a bulkhead.

## **D.2 General emergency alarm**

### **D.2.1 General**

On all passenger vessels an alarm system shall be provided by which the passengers and the crew can be warned or called to the quarters of assembly.

**D.2.2** Selective fused supply circuits shall be laid in the individual fire zones.

**D.2.3** The general emergency alarm shall be supplied from the main- and emergency source of electrical power. If the emergency source of electrical power is a generator, the general emergency alarm shall be supplied additionally from the transitional emergency source of electrical power.

**D.2.4** The alarm and the audible announcements in accordance with [Section 9, D.2.1](#) shall be both, separate for passengers and crew, and also together for them. The public address system shall be audible throughout the passenger and service area, the control and safety stations and on all open decks.

**D.2.5** Additional visual elements as per IMO MSC.1/Circ.1418 "Guidelines for the design and installation of a visible element to the general emergency alarm on passenger ships" shall be provided.

## **D.3 Fire detection and -alarm on ships with pressure water spraying systems (Sprinkler)**

**D.3.1** One of the following systems shall be provided for every separate vertical or horizontal fire zone in all accommodation and service rooms and insofar as necessary in all control stations, except in rooms which have no substantial fire risk, such as void spaces, sanitary rooms etc.:

- a) a fixed installed fire detection- and alarm system, so installed and arranged as to detect every fire in these spaces, or
- b) an automatic sprinkler-, fire detection- and fire alarm system, see the GL Rules for [Machinery Installations \(I-1-2\), Section 12, L.](#)

**D.3.2** An automatic sprinkler, fire detection and fire alarm system shall be installed in all service rooms, control stations and accommodation spaces including the passageways and stairs, see the GL Rules for [Machinery Installations \(I-1-2\), Section 12, L.](#)

## **D.4 Fire detection systems**

**D.4.1** In passenger ships, the control panel shall be located in the onboard safety centre.

**D.4.2** All accommodation and service rooms, enclosed staircases and passageways shall be equipped with a smoke detection- and alarm system. Exempted are sanitary rooms and areas constituting no substantial fire risk e.g. void spaces and similar areas.

In galleys, heat detectors may be fitted instead of smoke detectors or equivalent detectors.

Smoke detectors shall be fitted above suspended ceilings in staircases and passageways and in areas where ceilings are made of combustible materials. The distances between the detectors shall correspond with [Section 9, D.3.1.16](#), if no smaller distances are necessary due to reduced air circulation.

**D.4.3** Apart from the smoke detectors required for passageways, staircases and escape routes, other approved automatic fire detection devices may also be used in the accommodation and day rooms.

**D.4.4** The individual detection loops in the accommodation shall not cover more than 50 enclosed rooms with a maximum of 100 detectors.

**D.4.5** Fire detection and fire alarm systems shall be capable of remotely and individually identifying each detector and manually operated call point.

## Section 14 Additional Rules for Passenger Vessels

---

**D.4.6** Detectors fitted in cabins, when activated, shall also be capable of emitting, or cause to be emitted, an audible alarm within the space where they are located. To silence the local audible alarms from the fire alarm panel shall not be permitted.

**D.4.7** The monitored region of fire detection systems may simultaneously contain rooms on both sides of the ship and on several decks. However all these shall be located in the same main vertical fire zone, except on cabin balconies.

**D.4.8** If manually operated fire call points are not sufficiently illuminated by a nearby installed emergency light, they shall be provided with a guide light.

**D.4.9** Special spaces such as cargo rooms and car decks on Ro/Ro vessels for transportation of motor vehicles with fuel in their tanks, and non-accessible cargo rooms, shall be equipped with an approved automatic fire detection and alarm system, see [Section 16, D](#).

If in accordance with **SOLAS** special category spaces are continuously watched by a fire patrol, such spaces are only to be equipped with manually operated fire alarm call points.

The manually operated call points shall be distributed in sufficient quantity over the spaces and at every exit from these spaces.

**D.4.10** In accordance with the Fire Safety Systems Code (FSS Code) Chapter 9 a fixed fire detection and fire alarm system shall be installed on cabin balconies where furniture and furnishings other than those of restricted fire risk (flame retardant) are used.

Passenger ships constructed before 1 July 2008 shall comply with the requirements of this paragraph by the first survey after 1 July 2008.

**D.4.11** According to [Section 9, D](#) described requirements for fire detection and fire alarm systems, additional influences shall be observed on fire detections for cabin balconies:

- wind conditions
- sun irradiation
- ultraviolet exposure

**D.4.11.1** Type approved detectors shall be operated by heat, smoke flame or any combination of these factors. Other detectors can be used where the evidence of suitability is demonstrated by a type approval.

### **D.5 Fire door's closing system**

**D.5.1** The GL Rules for [Machinery Installations \(I-1-2\)](#), [Section 14, G](#) shall be observed.

**D.5.2** Electrical power shall be supplied from the emergency electrical power supply.

**D.5.3** Where monitoring and/or control of a fire door is processed by an address unit of the fire alarm system only those address units of the same fire zone may be combined to one loop.

Fire resistant cables shall be used, if the display on the bridge works on this address unit.

### **D.6 Fire door's closure indication**

**D.6.1** For all fire doors in main vertical zone bulkheads, galley boundaries and stairway enclosures an indication shall be provided at an indicator panel in a continuously manned control station whether each of the remote-released doors are closed.

**D.6.2** Electrical power shall be supplied from the emergency electrical power supply.

### **D.7 Watertight doors**

**D.7.1** The GL Rules for [Machinery Installations \(I-1-2\)](#), [Section 14, F.5](#) shall be observed.

**D.7.2** Electrical equipment shall as far as possible be installed above the bulkhead deck and outside of hazardous areas.

If electrical components are installed below the bulkhead deck, their protection against water shall have the following minimum degree:

- a) electric motors, associated circuits and monitoring equipment: IP X7
- b) door indicators and associated components: IP X8.

The water pressure test shall be based on the pressure that may built-up at the place of installation during flooding

- c) warning devices activated when the door closes: IP X6

**D.7.3** The power supply to the drives of the watertight doors and to their associated control- and monitoring equipment shall be provided either directly from the emergency switchboard or from a subdistribution panel located above the bulkhead deck and supplied from the emergency switchboard.

If the emergency electrical power supply is assured by a generator unit, the system shall be supplied for 30 minutes by the transitional emergency source of electrical power. During the period of supply from this source, there is no need to close all the doors simultaneously provided all doors can be closed within 60 s.

**D.7.4** Power-operated watertight doors shall be in case of electrical outfit and motor drive independent of each other and with their own power supply for opening and closing.

In case of main- or emergency electrical power supply failure the supply shall be automatically maintained from the transitional source of emergency electrical power, and with sufficient capacity to operate the door three times (closing-opening-closing).

**D.7.5** Failure of a power supply shall cause an optical and audible alarm in the central control station on the bridge.

**D.7.6** A single fault in the electrical power supply or in the control system of a power-operated door shall not cause a door opening.

**D.7.7** A single fault in the control unit of a power-operated drive, except in the closing hydraulic cylinder or in similar part shall not impair the working clearness of the manual operation.

**D.7.8** The operating console on the bridge shall be provided with a system schematic from which the arrangement of the watertight doors in the ship can be recognized. Indicating lights shall be provided showing whether a door is open or closed.

A red indicating light shall inform that the subject door is completely open and a green light, that it is completely closed.

If the door is in an interposition, e.g. still travelling this shall be indicated by the red indicating light blinking. The monitoring circuits shall be independent of the control- circuits of the individual doors.

**D.7.9** An opening of the watertight doors by central remote control is not permitted.

**D.7.10** The electrical controls, indicators and the possibly necessary power supply shall be so structured and fused that any fault in the electrical system of one of the doors does not impair, the functioning of other doors.

A short circuit and other faults in the alarm- or indicating circuit of a door shall not result in a failure of the power-operated drive of this door.

Entry of water into the electrical equipment of a door below the bulkhead deck shall not cause this door to open.

## **D.8 Indicating and monitoring systems for shell doors**

For Ro-Ro passenger vessels see [Section 16, E](#).



## **D.9 Continuously manned control station**

**D.9.1** The following alarms, indications and controls shall be provided in a continuously manned control station:

**D.9.1.1** Alarm, release of sprinklers, fire alarm

**D.9.1.2** Controls for fire doors closures

**D.9.1.3** Controls for shut down and switch-on of fans and indication of their status on/off

**D.9.1.4** Fire door position indicator panel

**D.9.2** Alarms shall be designed on the closed circuit principle.

**D.9.3** Where auxiliary supply is required for the indications according to [D.9.1.3](#) and [D.9.1.4](#), this supply shall be realised by the main source of power and the emergency source of power with automatic switch over in case of failure of the main source of power.

## **D.10 Flooding detection system**

**D.10.1** A flooding detection system for watertight spaces below the bulkhead deck shall be provided for passenger ships carrying 36 or more persons and constructed on or after 1 July 2010 as defined in **SOLAS**, Chapter II-1, Regulation 22-1.

**D.10.2** The flooding detection system sensors and associated equipment are subject to mandatory type approval.

### **D.10.3 Definitions**

**D.10.3.1** Flooding detection system means a system of sensors and alarms that detect and warn of water ingress into watertight spaces. Continuous flood level monitoring may be provided, but is not required.

**D.10.3.2** Sensor means a device fitted at the location being monitored that activates a signal to identify the presence of water at the location.

**D.10.3.3** Alarm means an audible and visual signal which announces a flooding condition requiring attention.

### **D.10.4 System installation**

**D.10.4.1** A flooding detection system shall be fitted in all watertight spaces below the bulkhead deck that:

- have a volume [m<sup>3</sup>], that is more than the ship's moulded displacement [cm] immersion at deepest subdivision draught; or
- have a volume more than 30 m<sup>3</sup>,

whichever is the greater.

**D.10.4.2** Any watertight spaces that are separately equipped with a liquid level monitoring system (such as fresh water, ballast water, fuel, etc.), with an indicator panel or other means of monitoring at the navigation bridge (and the safety centre if located in a separate space from the navigation bridge), are excluded from these requirements.

### **D.10.5 Sensor installation**

**D.10.5.1** The number and location of flooding detection sensors shall be sufficient to ensure that any substantial water ingress into a watertight space requiring a flooding detection system is detected under reasonable angles of trim and heel. To accomplish this, flooding detection sensors required in accordance with item [D.10.4.1](#) should generally be installed as indicated below:

- Vertical location – sensors should be installed as low as practical in the watertight space.

- Longitudinal location – in watertight spaces located forward of the mid-length, sensors should generally be installed at the forward end of the space; and in watertight spaces located aft of the mid-length, sensors should generally be installed at the aft end of the space. For watertight spaces located in the vicinity of the mid-length, consideration should be given to the appropriate longitudinal location of the sensor. In addition, any watertight space of more than  $L_s/5$  ( $L_s$  subdivision length) in length or with arrangements that would seriously restrict the longitudinal flow of water should be provided with sensors at both the forward and aft ends.
- Transverse location – sensors should generally be installed at the centreline of the space (or alternatively at both the port and starboard sides). In addition, any watertight space that extends the full breadth of the ship or with arrangements that would seriously restrict the transverse flow of water should be provided with sensors at both the port and starboard sides.

**D.10.5.2** Where a watertight space extends in height over more than one deck, there shall be at least one flooding detection sensor at each deck level. This is not applicable in cases where a continuous flood level monitoring system is installed.

### **D.10.6 Unusual arrangements**

**D.10.6.1** For watertight spaces with unusual arrangements or in other cases where this requirement would not achieve the intended purpose, the number and location of flooding detection sensors should be subject to special consideration.

### **D.10.7 Alarm installation**

**D.10.7.1** Each flooding detection system should give an audible and visual alarm at the navigation bridge and the safety centre, if located in a separate space from the navigation bridge. These alarms should indicate which watertight space is flooded.

**D.10.7.2** Visual and audible alarms should conform to the Code on Alerts and Indicators, 2009, as amended, as applicable to an alarm for the preservation or safety of the ship.

### **D.10.8 Design requirements**

**D.10.8.1** The flooding detection system and equipment shall be suitably designed to withstand supply voltage variation and transients, ambient temperature changes, vibration, humidity, shock, impact and corrosion normally encountered in ships. Sensor cabling and junction boxes shall be suitably rated to ensure operability of the detection system in a flooded condition. In addition, the detection system shall be designed on the fail-to-safety principle, where an open sensor circuit shall result in an alarm condition.

**D.10.8.2** The flooding detection system shall be supplied from the emergency and main source of electrical power. Each failure of the power supply shall be alarmed visually and audibly.

### **D.10.9 Detector maintenance, accessibility and testing**

**D.10.9.1** Documented operating, maintenance and testing procedures for the flooding detection system shall be kept on board and be readily accessible.

**D.10.9.2** Flooding detection system sensors and associated equipment shall be installed where they are accessible for testing, maintenance and repair.

**D.10.9.3** The flooding detection system shall be capable of being functionally tested using either direct or indirect methods. Records of testing shall be retained on board.

## **E Lighting**

### **E.1 Low-location lighting (LLL systems)**

**E.1.1** In passengers' and crews' accommodation all escape routes including stairs and exits shall be provided at all points on the route including the corners and intersections with electrically operated or

photoluminescent low-location lighting. The low-location lighting shall enable the passengers and crew to identify all escape routes and to recognize the emergency exits easily.

**E.1.2** Electrically supplied LLL-systems are subject to mandatory type approval.

**E.1.3** Electrical power shall be supplied from the emergency switchboard and shall be redundant arranged for each fire zone either by the use of fire-resistant cables or by local batteries including their chargers able to ensure an operation for at least 60 minutes in case of supply failure. Example for supply, see Fig. 14.1.

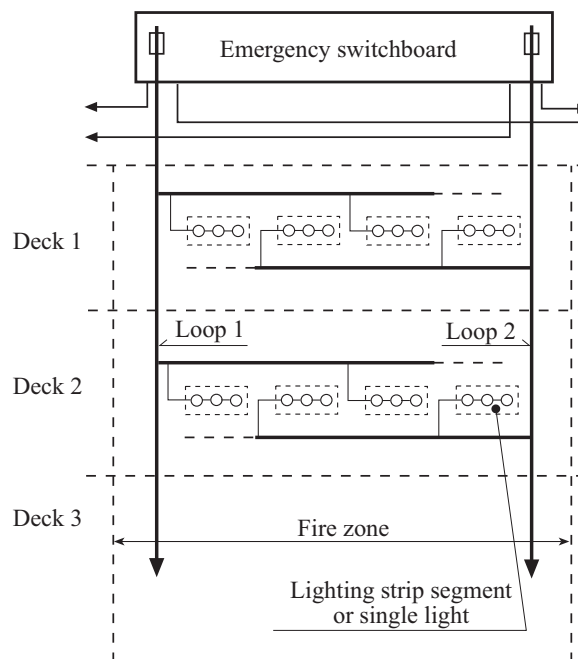

**Fig. 14.1 Specimen of supply layout-low-location lighting**

**E.1.4** The LLL-system shall be connectable from the permanent manned control station.

**E.1.5** The LLL-system shall be installed not more than 0.3 m above the deck and not more than 0.15 m distant from walls. Where a corridor or stair exceeds 2 m in width a low location lighting shall be installed at both sides.

**E.1.6** The design of the low-location lighting systems shall be made in accordance with the technical requirements of IMO resolution A. 752(18) and MSC/Circ.1167.

**E.2 Additional emergency lighting for Ro-Ro passenger vessels**

Ro-Ro passenger vessels shall be provided with an additional emergency lighting, see Section 16, F.

**E.3 Lighting system**

**E.3.1** If a ship is subdivided into main fire zones in accordance with SOLAS, at least two electric circuits, each of them with its own supply cable shall be provided for the lighting in each main fire zone. One circuit may be supplied from the emergency switchboard if this is continuously supplied. The supply cables shall be so arranged that in the event of a fire in one main fire zone the lighting is maintained in the other zones.

**E.3.2** Supplementary lighting shall be provided in all cabins to clearly indicate the exit so that occupants will be able to find their way to the door. Such lighting, which may be connected to the emergency source of power or have a self-contained source of electrical power in each cabin, shall automatically illuminate when power to the normal cabin lighting is lost and remain on for a minimum of 30 min.

## **F Cable Network**

### **F.1 Routing of cables**

On passenger ships, the main- and emergency supply cables which have to be run through a common vertical main fire zone shall be laid as far apart as practicable so that, in the event of a fire in this main fire zone, supply cables passing through to main and emergency equipment in other vertical and horizontal main fire zones remains, as far as possible, unaffected.

### **F.2 Selection of cables**

**F.2.1** In areas attended by passengers and in service areas only halogen-free cables shall be used for permanent installations. Cable trays/protective casings made of plastic materials as well as mounting materials shall be halogen-free as well.

Exceptions for individual cables for special purposes have to be agreed with GL.

**F.2.2** For all other areas of the ship, the use of halogen-free cables is recommended.

## Section 15 Additional Rules for Tankers

A	General .....	15-1
B	Oil Tankers, Cargo Flash Point above 60 °C .....	15-3
C	Oil Tankers, Cargo Flash Point 60 °C or below.....	15-4
D	Liquefied Gas Tankers.....	15-4
E	Chemical Tankers.....	15-4

### A General

#### A.1 Scope

These Rules apply additionally to electrical equipment on tankers for the carriage of liquids developing combustible gases or vapours.

#### A.2 References to other GL Rules and Guidelines

**A.2.1** [Section 1, K.3](#)

**A.2.2** [Hull Structures \(I-1-1\)](#)

**A.2.3** [Machinery Installations \(I-1-2\)](#)

**A.2.4** [Liquefied Gas Carriers \(I-1-6\)](#), see also IGC-Code of IMO

**A.2.5** [Chemical Tankers \(I-1-7\)](#), see also IBC-Code of IMO

**A.2.6** IEC publication 60092-502

**A.2.7** **SOLAS**

#### A.3 Hazardous areas

**A.3.1** Hazardous areas in which protective measures are mandatorily required are specified in [B](#) and [C](#) and in IEC 60092-502 and [Liquefied Gas Carriers \(I-1-6\)](#) and IGC-Code and [Chemical Tankers \(I-1-7\)](#) and IBC-Code.

**A.3.2** Areas on open deck, or semi-enclosed spaces on open deck, within 3 m of cargo tank ventilation outlets which permit the flow of small volumes of vapour or gas mixtures caused by thermal variation are defined as Zone 1. Areas within 2 m beyond the zone specified above are to be considered as Zone 2.

#### A.4 Power supply systems

**A.4.1** The following power supply systems are permitted:

**A.4.1.1** Direct current and single-phase alternating current:

- 2 conductors, insulated from ship's hull

**A.4.1.2** Three-phase alternating current:

- 3 conductors, insulated from ship's hull

**A.4.2** Systems with hull return, or systems with earthed neutral, or systems with earthed conductor are not permitted, except for locally limited hull return or neutral earthed systems which are located outside of hazardous areas for

- active corrosion protections
- measuring circuits of starting and preheating systems of internal combustion systems
- medium voltage systems without influence of hazardous areas (see [Section 8, C](#))

**A.4.3** The insulation resistance of non-earthed primary or secondary distribution systems passing through hazardous areas, or belonging to equipment in a hazardous area, shall be continuously monitored. Earth faults shall be alarmed (see [Sections 5, E](#) and [20, E](#)).

## **A.5 Cable installation**

**A.5.1** In hazardous areas, cables shall be laid only for equipment whose use is permitted in these areas; cables related to other requirements of this Section may also pass through these areas. Cables shall be reliably protected against damage.

**A.5.2** All cables liable to be exposed to the cargo, oil vapours or gases shall be armoured or shielded, and shall have an overall watertight and oil-resistant outer sheath.

**A.5.3** Each intrinsically safe system shall have its own separate cable. It is not permissible for intrinsically safe- and non-intrinsically safe circuits to lay these together in a cable bundle or pipe or to mount them under common clamps (see [Section 12, C.5.7](#)). Intrinsically safe cables shall be marked.

## **A.6 Electrical equipment in hazardous areas (zone 0 and 1) and extended hazardous areas (zone 2)**

**A.6.1** In principal electrical equipment of non-certified safe-type shall be installed outside of hazardous areas. Such equipment may be installed in enclosed or semi- enclosed rooms only if these are well ventilated and separated by cofferdams or equivalent spaces from the cargo tanks, and by oiltight and gastight bulkheads from cofferdams and cargo pump rooms. These rooms shall be accessible only from a non-hazardous area or through adequately ventilated air locks.

Electrical equipment of non-certified safe-type may be installed inside hazardous areas, if it belongs to an intrinsic safe circuit.

**A.6.2** The use of electrical equipment in hazardous areas shall be restricted to necessary required equipment.

**A.6.3** The explosion types of electrical equipment in hazardous areas shall be as mentioned

- in [Section 1, K.3.2](#) for Zone 0,
- in [Section 1, K.3.3](#) for Zone 1,
- in [Section 1, K.3.4](#) for Zone 2

and their explosion group and temperature class shall conform with the characteristics of the cargo.

### **A.6.4 Motors**

In case of motors with an explosion protection type Ex e (increased safety) these motors shall be equipped with protective devices for over current which shut-off the motors, if the winding temperatures rise to unacceptable high levels. Monitoring of the winding temperature does not replace the motor over current protection in the motor switchgear, which is required in all cases.

### **A.6.5 Measuring-, signalling-, control- and intercommunication circuits**

**A.6.5.1** According to the classified hazardous area the construction types Ex ia or Ex ib shall be preferred.

**A.6.5.2** The suitability of the systems for tank level gauging, tank pressure monitoring systems, high level alarm, overflow control and for required gas detection shall be proved by a GL type approval test, [Section 21, E.5.6](#).

## **A.7 Fans and ventilation**

**A.7.1** Fans intended for installation in hazardous areas shall be designed according to the GL Rules for [Machinery Installations \(I-1-2\), Section 15, B.5.3](#).

**A.7.2** Requirements for ventilation, see the GL Rules for [Ventilation \(I-1-21\)](#)

## **A.8 Integrated cargo and ballast systems**

**A.8.1** If the operation of cargo and/or ballast system is necessary under certain emergency circumstances or during navigation to ensure the safety of the tanker, measures are to be taken to prevent cargo and ballast pumps becoming inoperative simultaneously due to a single failure including its control and safety system.

**A.8.2** The emergency stop of the cargo and ballast systems are to be independent from the control circuits. A single failure in the control or emergency stop circuits shall not lead to an inoperative cargo and ballast system.

**A.8.3** Manual emergency stops of the cargo pumps shall not make the ballast pumps inoperative.

**A.8.4** The control system are to be provided with a backup power supply, which may be a second power supply from main switch board. A failure of any power supply shall cause an alarm, audible and visible at each control panel location.

**A.8.5** In the event of a failure of the automatic or remote control systems, a secondary means of control shall ensure the operation of the cargo and ballast system. This shall be achieved by manual overriding and/or redundant arrangements within the control systems.

## **A.9 Active cathodic protection systems**

**A.9.1** Metallic parts in hazardous areas shall not be provided with impressed current cathodic protection, unless specially designed and accepted by the authority.

**A.9.2** Cables for active corrosion protection systems, see [Section 1, K.3.3.3](#).

**A.10** For earthing, equipotential bonding and electrostatic charging see [Section 1, K.3.16](#).

## **B Oil Tankers, Cargo Flash Point above 60 °C**

**B.1** Where the cargoes are heated to a temperature within 10 °C of their flash point or above, the requirements of [C](#) are applicable.

**B.2** Where the cargoes are not heated or heated to not more than 10 °C below its flash point, extended hazardous areas (zone 2) are specified inside cargo tanks, slop tanks and any pipework for cargo and slop tanks or venting systems.

**B.2.1** To avoid possible sources of ignition, the following protective measures shall be applied:

**B.2.1.1** Electrical equipment, necessary to install in zone 2-spaces shall be of types mentioned in [Section 1, K.3.4.2](#).

**B.2.1.2** Cables shall not be laid inside of cargo tanks. Exceptions are made for cables leading to essential equipment located in the tanks. The cables shall be installed in thick-walled, gastight pipes up to a point above the main deck.

## **C Oil Tankers, Cargo Flash Point 60 °C or below**

### **C.1 Hazardous areas zone 0 and permitted electrical equipment**

**C.1.1** Hazardous areas (zone 0) are specified in IEC 60092-502, item 4.2.1

**C.1.2** Electrical equipment, necessary to install in zone 0- spaces shall be of types mentioned in [Section 1, K.3.2.2](#)

### **C.2 Hazardous areas zone 1 and permitted electrical equipment**

**C.2.1** Hazardous areas (zone 1) are specified in IEC 60092-502 item 4.2.2

**C.2.2** Electrical equipment, necessary to install in zone 1-spaces shall be of types mentioned in [Section 1, K.3.3.2](#)

### **C.3 Extended hazardous areas zone 2 and permitted electrical equipment**

**C.3.1** Extended hazardous areas (zone 2) are specified in IEC 60092-502 item 4.2.3

**C.3.2** Electrical equipment, necessary to install in zone 2-spaces shall be of types mentioned in [Section 1, K.3.4.2](#)

## **D Liquefied Gas Tankers**

Special requirements, see the GL Rules for [Liquefied Gas Carriers \(I-1-6\)](#) and IGC-Code of IMO.

Where the requirement in paragraph 3.2.4 of the IGC-Code is impossible in practice, or to unreasonable, to fulfil the requirements relating to the location of access doors (e.g., doors to forecastle spaces facing cargo area), air inlets or other openings in superstructures and/or deckhouses, alternative provisions may be accepted provided that, no ignition source is located in the hazardous areas, except for electrical installations that have the required protection and have been certified as safe according to IEC 60092-502.

## **E Chemical Tankers**

Special requirements, see the GL Rules for [Chemical Tankers \(I-1-7\)](#) and IBC-Code of IMO.

Where the requirement in paragraph 3.2.3 of the IBC-Code is impossible in practice, or to unreasonable, to fulfil the requirements relating to the location of access doors (e.g., doors to forecastle spaces facing cargo area), air inlets or other openings in superstructures and/or deckhouses, alternative provisions may be accepted provided that, no ignition source is located in the hazardous areas, except for electrical installations that have the required protection and have been certified as safe according to IEC 60092-502.



## Section 16 Additional Rules for Ships for the Carriage of Motor Vehicles

A	Scope .....	16-1
B	Protection Areas .....	16-1
C	Ventilation .....	16-2
D	Fire Alarm System .....	16-2
E	Indicating and Monitoring Systems for Shell Doors .....	16-2
F	Additional Requirements for the Illumination on Ro-Ro Passenger Vessels.....	16-4
G	Installation of Electrical Equipment in Protection Areas .....	16-4
H	Permissible Electrical Equipment .....	16-5
I	Requirements for Spaces intended for Carriage of Motor Vehicles with compressed Natural Gas in their Tanks for their own Propulsion as Cargo.....	16-7
J	Requirements for Spaces intended for Carriage of Motor Vehicles with compressed Hydrogen in their Tanks for their own Propulsion as Cargo .....	16-7

### A Scope

These Rules apply additionally to electrical equipment on cargo- and passenger ships for the transportation of motor vehicles which are driven on and off the ship by their built-in drives and/or have fuel in their tanks (Ro-Ro-ships).

In addition to the Parts B – H of this Section, the Requirements for vehicle carriers carrying motor vehicles with compressed hydrogen or natural gas in their tanks for their own propulsion as cargo, are added in Part I and J of this Section.

### B Protection Areas

Protection areas (zone 1) are areas in which an explosive atmosphere can be expected to be present occasionally (see Fig. 16.1). Such zones include the following:

#### B.1 Passenger ships

**B.1.1** Closed vehicle decks above the bulkhead deck (at least 10 air changes/hour) up to a height of 450 mm. The spaces above grating vehicle decks with adequate permeability are not deemed to be protection areas.

**B.1.2** Vehicle decks below the bulkhead deck extending to the full height.

**B.1.3** Holds for motor vehicles.

**B.1.4** Exhaust ducts from holds and vehicle decks.

#### B.2 Cargo ships

**B.2.1** Closed vehicle decks extending to the full height (with < 10 air changes/hour), or closed vehicle decks to a height of 450 mm (with ≥ 10 air changes/hour). Spaces above grating vehicles decks with adequate permeability are not deemed to be protection zones.

**B.2.2** Exhaust ducts from holds and vehicle decks.

## C Ventilation

**C.1** A forced-draught ventilation system is required to ensure a sufficient number of air changes during the loading, unloading and transportation of motor vehicles. For details, see the GL Rules for [Machinery Installations \(I-1-2\)](#), [Section 12](#), [B.11](#).

**C.2** On passenger ships, a fan failure<sup>1</sup> or failure related to the number of air changes specified for vehicle decks and holds shall be alarmed on the bridge.

**C.3** On cargo ships, a fan failure<sup>1</sup> shall be alarmed on the bridge.

**C.4** It shall be possible to switch ventilation systems on and off from a position outside the ventilated car decks or holds. Provision shall be made for the immediate shutdown and closure of the systems in the event of fire.

## D Fire Alarm System

**D.1** Unless enclosed car decks on passenger ships are under the supervision of a fire patrol during the transportation of vehicles, an automatic fire alarm system is required for these areas. The design of the system shall comply with the requirements set out in [Section 9, D](#) and [Machinery Installations \(I-1-2\)](#), [Section 12, C](#).

A sufficient number of manually operated call points shall be installed in the areas mentioned above. One call point shall be located close to each exit.

**D.2** Cargo holds for the carriage of vehicles with fuel in their tanks, and vehicle decks on cargo ships, shall be equipped with automatic fire alarm systems. The extent and execution of these systems shall conform to [Section 9, D](#) and [Machinery Installations \(I-1-2\)](#), [Section 12, C](#).

**D.3** Additional requirements see IMO circular MSC.1/Circ.1430 "Revised Guidelines for the Design and Approval of Fixed Water-Based Fire-Fighting Systems for Ro-Ro Spaces and Special Category Spaces".

## E Indicating and Monitoring Systems for Shell Doors

The following additional monitoring systems and indicators shall be provided on the bridge (see also the GL Rules for [Hull Structures \(I-1-1\)](#), [Section 6, H](#) and [J](#)).

### E.1 Bow doors and inner doors

**E.1.1** Bow doors and inner doors giving access to vehicle decks shall be equipped for remote operation from above the freeboard deck to enable the following for each door:

- closing and opening of the door and
- operation of the locking and securing devices.

An indication of the open/closed position of each locking and securing device shall be provided at the remote-operating position. The operating consoles serving the doors shall be accessible only to authorised personnel. A notice drawing attention to the fact that all locking devices shall be locked and secured before leaving harbour shall be fitted at every operating console. Furthermore appropriate warning indicator lights shall be provided.

---

<sup>1</sup> Monitoring of motor-fan switching devices is sufficient.

**E.1.2** Indicator lights shall be provided on the bridge and at the operating console for indication that the bow door and the inner door are closed and the locking and securing devices are in their correct positions. Deviations from the correct closed, locked and secured condition shall be indicated by optical and audible alarms.

The indicator panel shall be provided with

- a power failure alarm,
- an earth failure alarm,
- a lamp test and
- separate indication for door closed, door locked, door not closed and door not locked.

Switching the indicating lights off is not permitted.

**E.1.3** The indicating-system shall be self-monitored and shall provide optical and audible alarms if the doors are not completely closed and secured or the locking devices changes to the open position or the securing devices become untight. The power supply to the indicating-system shall be independent of that for opening and closing the doors and is to be provided with a backup power supply from the emergency source or secure power supply e.g. UPS. The sensors of the indicating-system shall be protected against water, icing-up and mechanical damage (minimum degrees of protection IP 56).

**E.1.4** The indicating-equipment on the bridge shall have a "Harbour/Sea" selector switch which initiates an alarm if the ship leaves the harbour with the bow or inner door not properly closed or with securing devices not in the correct position.

**E.1.5** A leakage-water monitoring system with audible alarm and television-supervision shall be provided which indicates on the bridge and in the machinery control room if water is leaking through the inner door.

**E.1.6** The space between bow door and inner door shall be provided with television-supervision and with monitors on the bridge and in the machinery control room. This supervision shall cover the position of the door and an adequate number of its locking and securing devices. Special attention shall be paid here to the illumination and the contrasts of the objects to be monitored.

**E.1.7** A drain system shall be provided between the bow door and the ramp. The same applies to the space between ramp and inner door with a corresponding arrangement. If the water level in this space reaches a height of 0.5 m above vehicle-deck level, an audible alarm shall sound on the bridge.

## **E.2 Side shell doors and stern doors**

**E.2.1** These requirements apply to side doors behind the collision bulkhead and to stern doors giving access to enclosed areas.

**E.2.2** The requirements set out in items [E.1.2](#), [E.1.3](#) and [E.1.4](#) also apply analogously to those doors which give access to special-category areas and Ro-Ro areas, as defined in Chapter II-2, Rule 3 of **SOLAS**, as these areas could be flooded through these doors.

These requirements apply also for side shell doors on cargo vessels, if the opening of a door exceeds 6 m<sup>2</sup> in size and for side shell doors below 6 m<sup>2</sup> in size where the sill of any side shell door is below the uppermost load line.

**E.2.3** On passenger ships a leakage monitoring system with an audible alarm and television supervision shall be provided which indicates on the bridge and in the machinery control room any leakage through these doors. On cargo ships a leakage monitoring system with an audible alarm shall be provided with a announcement on the bridge.

**E.3** The following additional measures are required on passenger ships:

**E.3.1** Indicators for all closed fire doors leading to the vehicle decks shall be provided on the bridge.

**E.3.2** Special-category areas and Ro-Ro cargo rooms shall either be included in the fire-rounds or be monitored by effective means such as television supervision, so that while the ship is under way any movement of the vehicles in heavy weather or unauthorised access by passengers can be watched.

## **F Additional Requirements for the Illumination on Ro-Ro Passenger Vessels**

### **F.1 Additional emergency luminaires**

**F.1.1** For emergency illumination in all rooms and passageways intended for passengers, except the cabins, additional emergency luminaires with integral batteries shall be provided.

Should all other sources of electrical power fail, access to the escape routes shall be easily recognisable.

The battery-powered luminaires shall as far as practicable be supplied from the emergency switchboard.

**F.1.2** If all other sources of electrical power fail these additional emergency luminaires shall remain operable for at least three hours regardless of their attitude. The power source for this luminaires shall be a continuously-charged battery placed inside each luminaire.

The service life of the batteries, taking into account the respective operating conditions, shall be stated by the maker.

A failure of a luminaire shall be immediately recognisable.

**F.1.3** All corridors of the crew's accommodation, the day rooms and usually manned workrooms are each to be provided with a portable, rechargeable battery-contained luminaire unless there is illumination provided in accordance with [F.1.1](#).

### **F.2 Low Location Lighting (LLL-System)**

**F.2.1** Low location lighting shall be provided, see [Section 14, E](#).

**F.2.2** The additional emergency luminaires required acc. to [F.1](#) may be fully or partly integral part of the LLL-system provided the additional requirements acc. to [F.1](#) are complied with.

## **G Installation of Electrical Equipment in Protection Areas**

**G.1** On principle the amount of electrical equipment installed shall be restricted to installations necessary for operation.

**G.2** All electrical equipment shall be permanently installed.

**G.3** Movable consumers or equipment supplied via flexible cables shall only be used with special permission or operated when there are no vehicles on board.

**G.4** Cables shall be protected against mechanical damage by covers.

Cables running horizontally are not permitted in the protection area extending to 45 cm above the enclosed vehicle deck.

## H Permissible Electrical Equipment

### H.1 Inside of the protection area (zone 1)

**H.1.1** Electrical equipment shall be of a certified safe type with Explosion Group IIA and Temperature Class T3.

**H.1.2** Certified safe type equipment in accordance with [Section 1, K.3.3.2](#) is permitted.

### H.2 Above the protection area (zone 2)

**H.2.1** Equipment in accordance with [Section 1, K.3.4.2](#) is permitted; the surface temperature shall not exceed 200 °C.

**H.2.2** Ventilation openings on open deck within 1 m surrounding for natural ventilation or 3 m surrounding for forced ventilation for rooms belonging to areas of zone 2, see [Fig. 16.1](#).

Section 16 Additional Rules for Ships for the Carriage of Motor Vehicles

**Passenger ship**

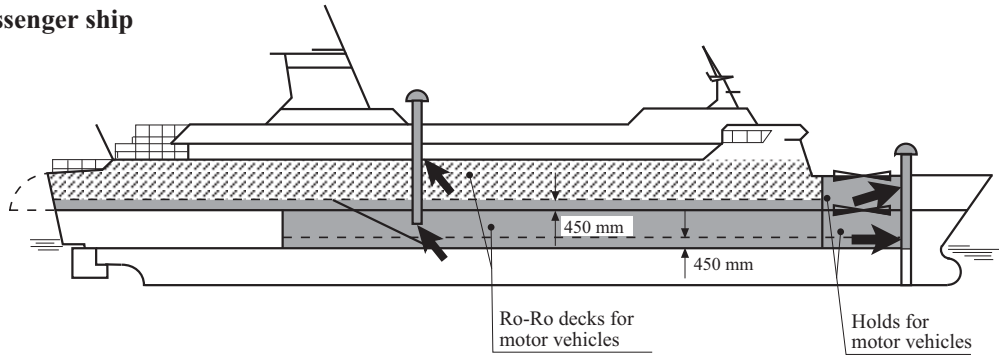

**Ro-Ro cargo ship**

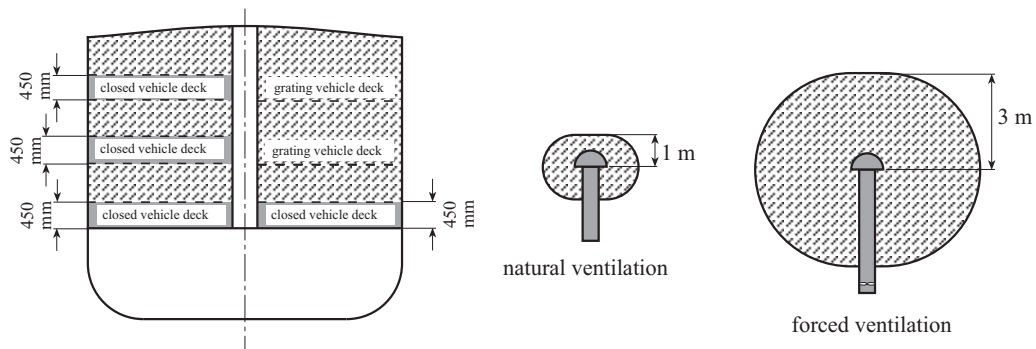
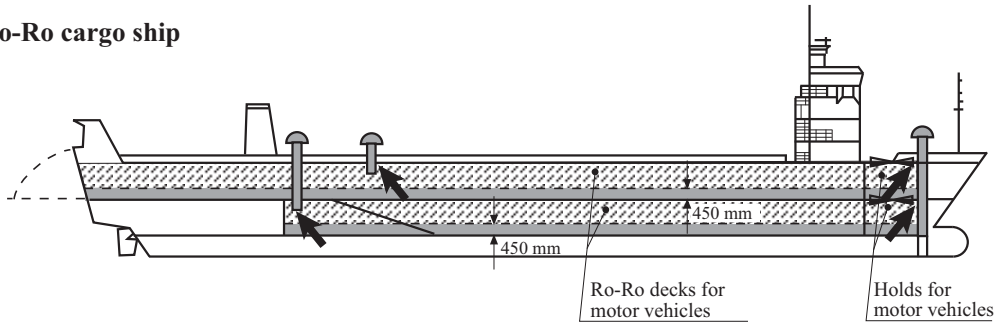

**Ro-Ro decks for motor vehicles**

Zones	Equipment design
above protection zone (zone 2)	IP 55 in conjunction with 10 changes of air per hour in the hold (see Section 1,K.3.4)
protection zone (zone 1)	certified safe type equipment (see Section 1,K.3.3)

**Fig. 16.1** Examples of protection areas on vehicle decks and in holds for the carriage of motor vehicles which are driven on and off the ship by their built-in drives and/or carry fuel in their tanks

## **I Requirements for Spaces intended for Carriage of Motor Vehicles with compressed Natural Gas in their Tanks for their own Propulsion as Cargo**

### **I.1 Electrical equipment and wiring**

All electrical equipment and wiring shall be of a certified safe type for use in an explosive methane and air mixture<sup>2</sup>.

### **I.2 Ventilation arrangement**

**I.2.1** Electrical equipment and wiring, if installed in any ventilation duct, shall be of a certified safe type for use in explosive methane and air mixtures.

**I.2.2** The fans shall be such as to avoid the possibility of ignition of methane and air mixtures. Suitable wire mesh guards shall be fitted over inlet and outlet ventilation openings.

### **I.3 Other ignition sources**

Other equipment which may constitute a source of ignition of methane and air mixtures shall not be permitted.

### **I.4 Detection**

When a vehicle carrier carries as cargo one or more motor vehicles with compressed natural gas in their tanks for their own propulsion, at least two portable gas detectors shall be provided. Such detectors shall be suitable for the detection of the gas fuel and be of a certified safe type for use in the explosive gas and air mixture.

## **J Requirements for Spaces intended for Carriage of Motor Vehicles with compressed Hydrogen in their Tanks for their own Propulsion as Cargo**

### **J.1 Electrical equipment and wiring**

All electrical equipment and wiring shall be of a certified safe type for use in an explosive hydrogen and air mixture<sup>2</sup>.

### **J.2 Ventilation arrangement**

**J.2.1** Electrical equipment and wiring, if installed in any ventilation duct, shall be of a certified safe type for use in explosive hydrogen and air mixtures and the outlet from any exhaust duct shall be sited in a safe position, having regard to other possible sources of ignition.

**J.2.2** The fans shall be designed such as to avoid the possibility of ignition of hydrogen and air mixtures. Suitable wire mesh guards shall be fitted over inlet and outlet ventilation openings.

### **J.3 Other ignition sources**

Other equipment which may constitute a source of ignition of hydrogen and air mixtures shall not be permitted.

---

<sup>2</sup> Refer to the recommendations of the International Electrotechnical Commission, in particular, publication IEC 60079.

#### **J.4 Detection**

When a vehicle carrier carries as cargo one or more motor vehicles with compressed hydrogen in their tanks for their own propulsion, at least two portable gas detectors shall be provided. Such detectors shall be suitable for the detection of the gas fuel and be of a certified safe type for use in the explosive gas and air mixture.



## Section 17 Additional Rules for Ships for the Carriage of Dangerous Goods

A	Scope .....	17-1
B	References to other Rules .....	17-1
C	Classes of Dangerous Goods .....	17-1
D	Hazardous Areas and permitted Electrical Equipment .....	17-2
E	Installation of Electrical Systems in Hazardous Areas .....	17-6
F	Certification if Installations not conform to the above Provisions .....	17-7
G	Fire Pumps.....	17-7
H	Alternative Electrical Power Supply for Ships intended for the Carriage of packaged irradiated Nuclear Fuel, Plutonium and high-level radioactive Wastes....	17-7

### A Scope

These Rules apply to the electrical installations on ships with cargo spaces intended for the transportation of dangerous goods, except for liquids and gases carried in bulk (tankers).

### B References to other Rules

- B.1** SOLAS, Chapter II-2, Regulation 19, "Special requirements for ships carrying dangerous goods"
- B.2** SOLAS, Chapter VII, "Carriage of dangerous goods"
- B.3** "International Maritime Solid Bulk Cargoes Code" (IMSBC Code)
- B.4** "International Maritime Dangerous Goods Code" (IMDG Code)
- B.5** [Machinery Installations \(I-1-2\), Section 12, P and Q](#)
- B.6** IEC publication 60092-506

### C Classes of Dangerous Goods

The dangerous goods for which safety measures regarding the electrical equipment are required are committed in SOLAS, Chapters II-2 Reg. 19, IMDG Code and IMSBC Code and they are divided into the following classes:

#### C.1 Dangerous goods in packaged form

Class 1.1 - 1.6 Explosive materials, except for goods of class 1 in division 1.4, compatibility group S <sup>1</sup> (IMDG Code)

---

<sup>1</sup> Reference is made to SOLAS, Chapter II-2, Regulation 19, Table 19.3

Section 17 Additional Rules for Ships for the Carriage of Dangerous Goods

---

- Class 2.1 All flammable gases, compressed, liquefied or dissolved under pressure
- Class 2.3 All toxic gases having a subsidiary risk Class 2.1
- Class 3 All flammable liquids with a flash point below 23 °C (closed-cup test)
- Class 4.3 Substances in liquid form which, in contact with water, emit flammable gases with a flash point < 23 °C
- Class 6.1 All poisonous (toxic) substances with a flash point < 23 °C (closed-cup test)
- Class 8 All corrosive substances with a flash point < 23 °C (closed-cup test)
- Class 9 Miscellaneous dangerous substances and articles evolving flammable vapours

**C.2 Solid dangerous goods in bulk**

- Class 4.1 Flammable solid substances
- Class 4.2 Substances liable to self-ignition  
only applicable to seed cake containing solvent extractions, iron oxide, spent and iron sponge, spent
- Class 4.3 Substances which in contact with water, emit flammable gases
- Class 5.1 Oxidizing substances  
only applicable to ammonium nitrate fertilizers
- Class 9 Miscellaneous dangerous substances, which, proven by experience, be of such a dangerous character that the provisions of this Section shall apply to them  
only applicable to ammonium nitrate fertilizers
- MHB Materials which, if carried in bulk, constitute a risk and require certain precautions

## D Hazardous Areas and permitted Electrical Equipment

Hazardous areas are areas in which the cargo carried, specified under [C](#), can give rise to potentially explosive or explosive atmospheres.

Explosion-protection measures are required in these areas.

**D.1** Hazardous areas comprise the following:

**D.1.1** Areas in which a dangerous gas/air mixture, dangerous vapours or a dangerous quantity and concentration of dust are liable to occur from time to time are defined to be areas subject to explosion hazard (zone 1).

**D.1.2** Areas in which a dangerous gas/air mixture, dangerous vapours or a dangerous quantity and concentration of dust are liable to occur only rarely, and then only for a brief period, are defined to be extended dangerous areas (zone 2).

**D.1.3** For the definition of hazardous areas, see [Section 1, B.11](#).

**D.2** Electrical equipment shall be installed in hazardous areas only when it is unavoidable for operational reasons. The explosion protection of the installed and operated electrical equipment shall meet the characteristics of the dangerous cargo.

**D.3** Electrical equipment is defined as a certified safe type if it is manufactured to a recognized standard, such as IEC Publication 60079 or EN 50014-50020, and has been tested and approved by an approval authority recognized by GL.

**D.4** Hazardous areas for which protective measures are required on principle, and the permitted electrical equipment, are described in the following paragraphs.

**D.4.1 Carriage of explosive substances in packaged form, according to class 1 (see C.1), except goods in division 1.4, compatibility group S**

**D.4.1.1** Hazardous areas (zone 1) (see Fig. 17.1 and Fig. 17.2)

- a) Closed cargo spaces, and closed or open Ro-Ro cargo spaces
- b) Stationary containers (e.g. magazines)

**D.4.1.2** Minimum requirements for electrical equipment

- a) Explosive, dusty atmosphere:
  - degree of protection IP65
  - maximum surface temperature 100 °C
- b) Potentially explosive, gaseous atmosphere:  
Certified safe type equipment in
  - explosion group IIA
  - temperature class T5
  - cables as described in E
- c) Explosive dusty and potentially explosive gaseous atmosphere: the requirements of a) and b) shall be fulfilled.
- d) The following certified safe type equipment may be used for b) and c):
  - Ex i, intrinsic safety
  - Ex d, flame-proof enclosure
  - Ex e, increased safety, only for luminaires
  - other certified safe type equipment may be used if safe operation in the atmosphere to be expected is guaranteed

**D.4.2 Carriage of solid goods in bulk which may develop dangerous dust only (see C.2)**

**D.4.2.1** Hazardous areas (zone 1) (see Fig. 17.1 and Fig. 17.2)

- a) Closed cargo spaces
- b) Ventilation ducts for hazardous areas
- c) Enclosed or semi-enclosed spaces with non-closable (e.g. by doors or flaps) direct openings to a) or b)

**D.4.2.2** Minimum requirements for electrical equipment (see also Section 1, K.3.3)

- degree of protection IP55 (except for fire detectors)
  - maximum surface temperature 200 °C
- or explosion-protected equipment
- degree of protection IP55 (except for fire detectors)
  - temperature class T3
  - cables, as described in E

**D.4.2.3** Where the characteristics of the cargo demand a lower surface temperature, this shall be considered (see also D.5).

**D.4.3 Carriage of liquids with a flash point < 23 °C in packaged form, flammable gases (see C.1) and highly dangerous bulk cargoes which, under certain conditions, develop a potentially explosive gaseous atmosphere (see C.2)**

**D.4.3.1** Hazardous areas (zone 1) (see Fig. 17.1 and Fig. 17.2)

- a) Closed cargo spaces and closed or open Ro-Ro cargo spaces

- b) Ventilation ducts for hazardous areas
- c) Enclosed or semi-enclosed rooms with non-closable (e.g. by doors or flaps) direct openings to a) or b)
- d) Areas on open deck or semi-enclosed spaces on open deck within 1.5 m of any ventilation opening as described in b)

**D.4.3.2** Minimum requirements for certified safe type equipment for areas specified in [D.4.3.1.a](#)) to d):

- explosion group II C
- temperature class T4
- cables, as described in [E](#).

If no hydrogen or hydrogen mixtures can be emitted by afore mentioned substances under [C](#), the explosion group II B can be applied for electrical equipment, see also [D.5](#) and [F](#).

#### **D.4.4 Extended hazardous areas and permitted equipment**

**D.4.4.1** Extended hazardous area (zone 2) (see [Fig. 17.1](#) and [Fig. 17.2](#))

- a) Areas which can be separated by gas-tight doors from hazardous areas

Weathertight doors are considered to be adequately gastight.

These areas pass for safe if they

- have overpressure mechanical ventilation with at least 6 changes of air per hour. Should the ventilation fail, this shall be announced optically and audibly and the facilities not permitted for the extended hazardous area shall be switched off (see also [D.4.4.3](#))

or

- are naturally ventilated and protected by airlocks.

- b) Enclosed spaces like bilge pump rooms or pipe tunnels containing ducts or pipes with flanges, valves or pumps and open ends to hazardous areas.

These areas pass for safe if they are mechanically ventilated with at least 6 changes of air per hour. Should the ventilation fail, this shall be announced optically and audibly and the equipment not permitted for the extended hazardous area shall be switched off (see also [D.4.4.3](#)),

- c) Areas of 1.5 m surrounding open or semi-enclosed spaces of zone 1 as described in [D.4.3.1 d\)](#)

**D.4.4.2** Minimum requirements for electrical equipment for the areas specified in [D.4.4.1 a\) - c\)](#)

- a) Use of certified safe type equipment, as for hazardous areas or
- b) Use of equipment with Ex n type protection or
- c) Use of equipment which does not produce sparks in normal operation and whose surfaces do not attain inadmissible temperatures or
- d) Equipment with simplified pressurized enclosure or a vapour-tight enclosure (minimum degree of protection IP55), and whose surfaces do not attain inadmissible temperatures
- e) Installation and cables, as described in [E](#)

#### **D.4.4.3 Essential equipment**

In ventilated rooms, equipment important for the safety of the crew or the ship shall be so designed that it fulfils the requirements for unventilated spaces. It shall not be switched off.

#### **D.5 Special assessments**

**D.5.1** If no details of the characteristics of the prospected cargo are available, or if a ship is intended to be used for the carriage of all the materials defined in [C](#), the electrical equipment shall fulfil the following requirements:

- degree of protection IP65 (except for fire detectors)
- maximum surface temperature 100 °C
- explosion group II C

Section 17 Additional Rules for Ships for the Carriage of Dangerous Goods

- temperature class T5

**D.5.2** On ships intended exclusively for the carriage of containers, where containers with dangerous goods (see D.5.1) are stowed in the cargo hold (with the exception of class 1 goods, hydrogen and hydrogen mixtures), the electrical equipment shall fulfil the following requirements:

- degree of protection IP55 (except for fire detectors)
- maximum surface temperature 135 °C
- explosion group II B
- temperature class T4

**D.5.3** Deviations from the provisions stated in D.5.1 or D.5.2 are possible. They are noted in the certificate and restrict the carriage of dangerous goods in accordance with the characteristics of the materials and the equipment.

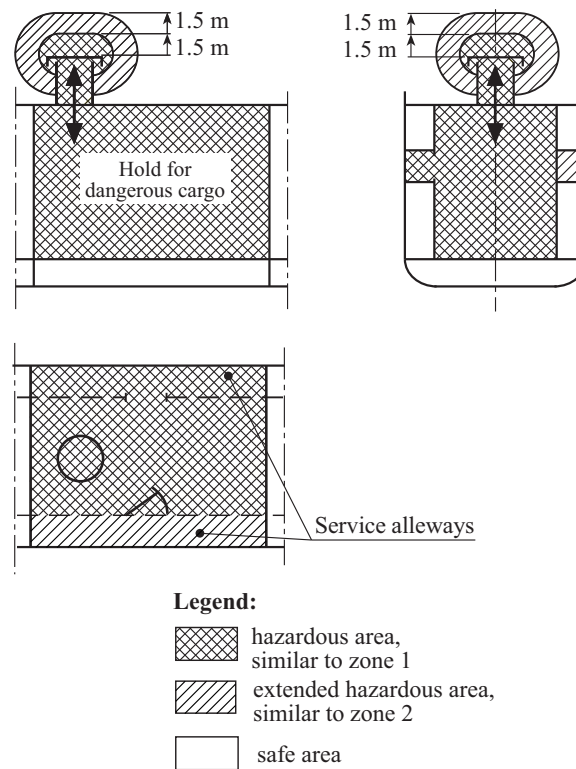

**Fig. 17.1** Examples for service alleyways, open to the hold and lockable with door

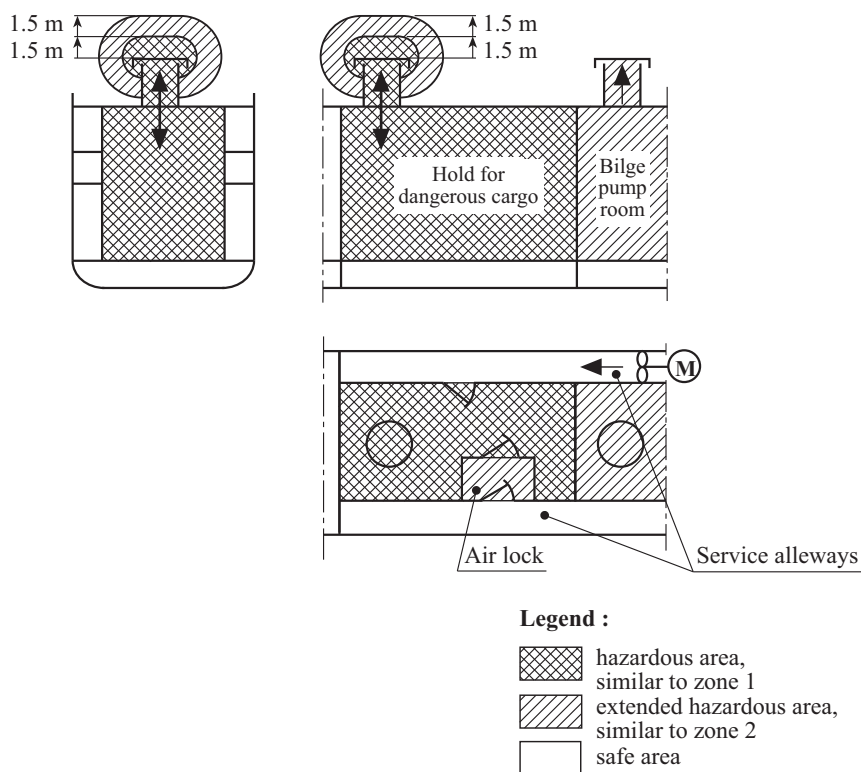

Fig. 17.2 Examples for service alleyways, lockable with door and air lock to the hold

## E Installation of Electrical Systems in Hazardous Areas

### E.1 Installation of electrical equipment in hazardous area (zone 1)

**E.1.1** If electrical equipment is installed which is not suitable for use in areas with an explosion hazard, it shall be capable of being switched-off and safeguarded against unauthorized re-switching. The switching devices shall be located outside the hazardous area, and shall, wherever possible, consist of isolating links or lockable switches.

Where electrical equipment is important for the safety of the crew or the ship, it shall not be switched-off and shall be approved for use in hazardous areas.

**E.1.2** Cables shall be armoured or shall have a braided screen, unless they are laid in metallic conduits.

**E.1.3** Bulkhead- and deck penetrations shall be sealed to prevent the passage of gases or vapours.

**E.1.4** Portable electrical equipment, important for aboard operation and used in hazardous areas or stipulated for such use by regulations shall be of a certified safe type.

### E.2 Installation of electrical equipment in extended hazardous areas (zone 2)

**E.2.1** If electrical equipment is installed which is not suitable for the use in extended dangerous areas, it shall be capable of being switched-off and safeguarded against unauthorized re-switching. Switching-off shall be made outside of the hazardous area, unless the switching devices are approved for this area.

Where electrical equipment is important for the safety of the crew or the ship, it shall not be switched-off and shall be approved for the use in extended hazardous areas.

**E.2.2** Cables shall be protected installed.

## F Certification if Installations not conform to the above Provisions

In the event of non-conformity with the above provisions, the lowest relevant explosion group and temperature class are entered in the certificate for the carriage of dangerous goods.

## G Fire Pumps

If the fire main pressure drops, the fire pumps shall start automatically or shall be switched on by a remote-starting device installed on the bridge, see also the GL Rules for [Machinery Installations \(I-1-2\), Section 12](#).

## H Alternative Electrical Power Supply for Ships intended for the Carriage of packaged irradiated Nuclear Fuel, Plutonium and high-level radioactive Wastes

Regarding the alternative electrical power supply the IMO Resolution MSC.88(71) (INF-Code) shall be observed.

**Table 17.1 Example for characteristics of Electrical Equipment for Use in Hazardous Areas (Zone 1) for the Carriage of Solid Dangerous Goods in Bulk and Materials Hazardous only in Bulk (MHB)**

Bulk Cargo Shipping Name (BCSN)	Class	Hazard	Protection against explosive atmosphere		
			Explosion group	Temperature class	Dusts
					Degree of protection
ALUMINIUM FERROSILICON POWDER UN 1395	4.3	H <sub>2</sub>	IIC	T2	-
ALUMINIUM SILICON POWDER, UNCOATED UN 1398	4.3	H <sub>2</sub>	IIC	T2	-
ALUMINIUM SMELTING BY-PRODUCTS or ALUMINIUM REMELTING BY-PRODUCTS UN 3170	4.3	H <sub>2</sub>	IIC	T2	-
ALUMINIUM SMELTING / REMELTING BY-PRODUCTS, PROCESSED	MHB	H <sub>2</sub>	IIC	T1	
AMMONIUM NITRATE UN 1942	5.1	Decomposition	-	T3	-
AMMONIUM NITRATE BASED FERTILIZER UN 2067	5.1	Decomposition	-	T3	-
AMMONIUM NITRATE BASED FERTILIZER UN 2071	9	Decomposition	-	T3	-
BROWN COAL BRIQUETTES	MHB	Dust, methane	IIA	T4	IP55
COAL	MHB	Dust, methane	IIA	T4	IP55
DIRECT REDUCED IRON (A) Briquettes, hot-moulded	MHB	H <sub>2</sub>	IIC	T2	-

**Table 17.1 Example for characteristics of Electrical Equipment for Use in Hazardous Areas (Zone 1) for the Carriage of Solid Dangerous Goods in Bulk and Materials Hazardous only in Bulk (MHB) (continued)**

Bulk Cargo Shipping Name (BCSN)	Class	Hazard	Protection against explosive		
			atmosphere		dusts
			Explosion group	Temperature class	Degree of protection
DIRECT REDUCED IRON (B) Lumps, pellets, cold-moulded briquettes	MHB	H <sub>2</sub>	IIC	T2	-
DIRECT REDUCED IRON (C) (By-product fines)	MHB	H <sub>2</sub>	IIC	T2	-
Dust (e.g. from grain)	-	Dust	-	-	IP55
FERROPHOSPHORUS	MHB	H <sub>2</sub>	IIC	T1	-
FERROSILICON	MHB	H <sub>2</sub>	IIC	T1	-
FERROSILICON UN 1408	4.3	H <sub>2</sub>	IIC	T1	-
IRON OXIDE, SPENT or IRON SPONGE, SPENT UN 1376	4.2	Dust	IIA	T2	IP55
SEED CAKE, containing vegetable oil UN 1386 (b)	4.2	Hexane	IIA	T3	-
SEED CAKE UN 2217	4.2	Hexane	IIA	T3	-
SILICOMANGANESE (low carbon)	MHB	H <sub>2</sub>	IIC	T1	-
SOLIDIFIED FUELS RECYCLED FROM PAPER AND PLASTICS	MHB	Combustible	-	T3	IP55
SULPHUR UN 1350	4.1	Combustible	-	T4	IP55
WOOD TORREFIED	MHB	Combustible	-	T3	IP55
ZINC ASHES UN 1435	4.3	H <sub>2</sub>	IIC	T2	-
<b>Note</b> The term "Hazard" relates exclusively to the danger of explosion attributable to the dangerous goods and the electrical appliances.					



## Section 18 Additional Rules for Bulk Carriers and Single Hold Cargo Ships other than Bulk Carriers

A	General .....	18-1
B	Water Level Detectors .....	18-1

### A General

#### A.1 Scope

These requirements apply additionally to electrical plants on

- bulk carriers, or
- single hold cargo ships other than bulk carriers constructed before 1 January 2007 shall comply with the requirements not later than 31 December 2009, or
- cargo ships having a length (L) of less than 80 m, or 100 m if constructed before 1 July 1998, and a single cargo hold below the freeboard deck or cargo holds below the freeboard deck which are not separated by at least one bulkhead made watertight up to that deck, except for ships complying with regulation XII/12, or in ships having watertight side compartments each side of the cargo hold length extending vertically at least from inner bottom to freeboard deck.

#### A.2 References to other GL Rules

[Hull Structures \(I-1-1\), Section 23](#)

### B Water Level Detectors

#### B.1 General

##### B.1.1 Definition

Water level detectors means a system comprising sensors and indication devices that detect and warn of water ingress in cargo holds and other spaces as required for bulk carriers in **SOLAS** regulation XII/12.1 and for single hold cargo ships other than bulk carriers as required in **SOLAS** "Amendments 2003, 2004 and 2005" regulation 23-3.

##### B.1.2 Means of detecting water ingress

**B.1.2.1** The method of detecting water ingress may be by direct or indirect means.

A direct means of detection determines the presence of water by physical contact of the water with the detection device.

Indirect means of detection include devices without physical contact with the water.

**B.1.2.2** The location shall be either as

- close to the centre line as practicable
- or located at both the port and starboard sides, if practicable.

For bulk carrier the detectors are also to be located in the aft part of each cargo hold or in the lowest part of the spaces other than cargo holds to which these rules apply.

For single hold cargo ships other than bulk carrier the detectors are also to be located in the aft part of the hold or above its lowest point in such ships having an inner bottom not parallel to the designed waterline. Where webs or partial watertight bulkheads are fitted above the inner bottom, Administrations may require the fitting of additional detectors.

**B.1.2.3** The systems of detecting water level shall be capable of continuous operation while the ship is at sea.

**B.1.2.4** Cargo holds shall be monitored for a pre-alarm and a main-alarm water level. Compartments other than cargo holds shall be monitored for the presence of water.

Pre-alarm level means the lower level at which the sensor(s) in the cargo hold space will operate. The pre-alarm is to indicate a condition that requires prompt attention to prevent an emergency condition.

Main alarm level means the higher level at which the sensor(s) in the cargo hold space will operate or the sole level in spaces other than cargo holds. The main-alarm is to indicate that immediate actions are to be taken to prevent danger to human life or to the ship.

**B.1.2.5 Documents for submission:**

Documents for submission shall contain the following information and operational instructions:

- line diagrams of the detection and alarm system showing the positions of equipment
- list of cargoes for which the performance of the detector has been demonstrated and certified, with information and/or evidence of certification for the certified safe type electrical equipment, if fitted
- maintenance requirements for equipment and system
- installation instructions for orientation, setting, securing, protecting and testing
- procedures to be followed in the event equipment not functioning correctly
- a description of the equipment for detection and alarm arrangements together with a listing of procedures for checking that as far as practicable, each item of equipment is working properly during any stage of ship operation
- a test procedure for the tests on board according to [B.5.2](#)
- type test certificate(s) for the system

Manuals shall be provided on board.

**B.2 Installations**

**B.2.1** Detectors, electrical cables and any associated equipment installed in cargo holds are to be protected from damage by cargoes or mechanical handling equipment.

**B.2.2** Any changes/modifications to the ship's structure, electrical systems or piping systems are to be approved by GL before work is carried out.

**B.2.3** Detectors and equipment are to be installed where they are accessible for survey, maintenance and repair.

**B.3 Detector system requirements**

**B.3.1 General**

**B.3.1.1** Detector systems are to provide a reliable indication of water reaching a preset level and are to be type tested. One sensor capable of detecting both preset levels (pre-alarm level and main alarm level) is allowed.

**B.3.1.2** The detector arrangement in cargo holds shall be capable to detect the water level in two steps, at a pre- and a main-alarm level. In compartments other than cargo holds one detection level is sufficient.

**B.3.1.3** Detectors shall be capable to operate in cargo/water mixture for the selected range of cargoes such as iron ore dust, coal dust, grains and sand using sea water with a suspension of representative fine material for each cargo.

**B.3.1.4** The detector shall activate the corresponding alarm within  $\pm 100$  mm of the pre-set level. Water density is to be taken as between 1000 and 1025 kg/m<sup>3</sup>.

**B.3.1.5** The installation of detectors shall not inhibit the use of any sounding pipe or other water level gauging device for cargo holds or other spaces.

**B.3.1.6** Detectors are to be capable of being functionally tested in fitted condition when the hold is empty using either direct or indirect means.

**B.3.1.7** Detectors have to be of the fail-safe type such that wire break and short circuit is to be indicated by an alarm. See also [B.4.1.4](#).

### **B.3.2 Requirements depending on location**

**B.3.2.1** Protection of the enclosures of electrical components installed in the cargo holds, ballast tanks and dry spaces is to satisfy the requirements of IP 68 in accordance with IEC publication 60529.

**B.3.2.2** Protection of the enclosures of electrical equipment installed above ballast and cargo spaces is to satisfy the requirements of IP 56 in accordance with IEC publication 60529.

**B.3.2.3** Detection equipment is to be corrosion resistant for all environments that may be experienced in cargo holds and dry/ballast spaces. The manufacturer is to declare a list of environments for which the detection equipment is suitable for use.

**B.3.2.4** Detectors and electrical cables to be installed in holds intended for use with cargoes that require protection against ignition caused by electrical installations are to be of a certified safe type (Ex ia).

Where a ship is designed only for the carriage of cargoes that cannot create a combustible or explosive atmosphere then the requirement for intrinsically safe circuitry should not be insisted upon, provided the operational exclude the carriage of cargoes that could produce a potential explosive atmosphere.

**B.3.2.5** Detectors are to be suitable for the cargo intended to be transported, including exposure to dust environments associated with bulk cargoes.

**B.3.2.6** The maximum surface temperature of equipment installed within cargo spaces should be appropriate for the combustible dusts and/or explosive gases likely to be encountered. Where the characteristics of the dust and gases are unknown, the maximum surface temperature of equipment should not exceed 85 °C.

## **B.4 Alarm system requirements**

### **B.4.1 General**

Visual and audible alarms are to be in accordance with IMO-Resolution A.1021 (26) "Code on Alerts and Indicators, 2009" as applicable to a Primary Alarm for the preservation or safety of the vessel.

Requirements stated in the GL Rules [Automation \(I-1-4\)](#) for alarm and monitoring systems shall be observed.

**B.4.1.1** The alarms shall be located on the navigation bridge. The signalisation shall be suitable for this environment and shall not seriously interfere with other activities necessary for the safe operation of the ship.

**B.4.1.2** Alarm systems are to be type tested.

**B.4.1.3** A switch for testing audible and visual alarms is to be provided at the alarm panel and the switch shall return to the off position when not operated.

**B.4.1.4** The complete system including the detectors is to be of the self-monitoring type and any fault associated with the system that include open circuit, short circuit, as well as loss of power supplies and CPU failure shall be alarmed.

**B.4.1.5** The detection of a preset level of water in any space shall activate an alarm indicating the space affected and the preset level of water that has been detected.

**B.4.1.6** The audible alarm signalisation shall distinguish between pre- and main-alarm level.

The pre-alarm, as a primary alarm, should indicate a condition that requires prompt attention to prevent an emergency condition and the main alarm, as an emergency alarm should indicate that immediate actions must be taken to prevent danger to human life or to the ship.

**B.4.1.7** Time delays may be incorporated into the alarm system to prevent spurious alarms due to sloshing effects associated with ship motions.

**B.4.1.8** For cargo holds the system shall be capable of the following:

**B.4.1.8.1** An alarm, both visual and audible, activated when the depth of water at the sensor reaches the pre-alarm level in the space being monitored. The indication shall identify the space.

For bulk carrier the pre-alarm level is 0.5 m above the inner bottom.

For single hold cargo ships other than bulk carriers the pre-alarm level is not less than 0.3 m above the inner bottom.

**B.4.1.8.2** An alarm, both visual and audible, activated when the level of water at the sensor reaches the main alarm level, indicating increasing water level in a cargo hold. The indication shall identify the space and the audible alarm shall not be the same as that for the pre-alarm level.

For bulk carrier the alarm level is at a height not less than 15 % of the depth of the cargo hold but not more than 2 m.

For single hold cargo ships other than bulk carriers the water level detectors shall give an audible and visual alarm at the navigation bridge when the water level above the inner bottom in the cargo hold reaches a height of not less than 0.3 m, and another when such level reaches not more than 15 % of the mean depth of the cargo hold.

**B.4.1.9** For compartments other than cargo holds the system shall be capable of the following:

**B.4.1.9.1** An alarm, both visual and audible, indicating the presence of water in a compartment other than a cargo hold when the level of water in the space being monitored reaches the sensor. The visual and audible characteristics of the alarm indication shall be the same as those for the main alarm level in a hold space.

For bulk carrier the water level detectors in any ballast tank forward of the collision bulkhead required by **SOLAS** regulation II-1/11, giving an audible and visual alarm when the liquid in the tank reaches a level not exceeding 10 % of the tank capacity. An alarm overriding device may be installed to be activated when the tank is in use. Also for bulk carrier the water level detectors in any dry or void space other than a chain cable locker, any part of which extends forward of the foremost cargo hold, giving an audible and visual alarm at a water level of 0.1 m above the deck. Such alarms need not be provided in enclosed spaces the volume of which does not exceed 0.1 % of the ship's maximum displacement volume.

## **B.4.2 Override**

**B.4.2.1** The system may be provided with a capability of overriding indication and alarms for the detection system installed only in tanks and holds that have been designed for carriage of water ballast.

**B.4.2.2** Where such an override capability is provided, cancellation of the override condition and reactivation of the alarm shall automatically occur after the hold or tank has been deballasted to a level below the lowest alarm indicator level.

## **B.4.3 Power supply**

**B.4.3.1** The alarm system is to be supplied from two separate sources. One is to be the main source of electrical power and the other is to be the emergency source of electrical power.

**B.4.3.2** Failure of the primary electrical power supply is to be indicated by an alarm.

**B.4.3.3** The secondary power supply may be a continuously charged dedicated accumulator battery, having arrangement, location and endurance equivalent to that of the emergency source, see [Section 20, D](#). The battery may be an internal battery in the water level detector system.

**B.4.3.4** Where an accumulator battery is used for the secondary power supply, failure of both power supplies are to be indicated by dedicated alarms.

## **B.5 Tests**

### **B.5.1 Type test**

**B.5.1.1** The Detectors and the Alarm System is subject to mandatory type testing. Basis are the GL Guidelines for [Test Requirements for Electrical / Electronic Equipment and Systems \(VI-7-2\)](#).

**B.5.1.2** For type test purposes an agitated suspension of representative fine materials in seawater, with a concentration of 50 % by weight, is to be used with the complete detector installation including any filtration devices fitted.

The functioning of the detection system with any filtration arrangements is to be verified in the cargo/water mixture repeated ten times without cleaning.

**B.5.1.2.1** The cargo/water mixture used for type testing should be representative of the range of cargoes within the following groups and should include the cargo with the smallest particles expected to be found from a typical representative sample:

- Iron ore particles should mainly consist of small loose screenings of iron ore and not lumps of ore (dust with particle size < 0.1 mm).
- Coal particles should mainly consist of small loose screenings of coal and not lumps of coal (dust with particle size < 0.1 mm).
- Grain particles should mainly consist of small loose grains of free-flowing grain (grain having a size > 3 mm, such as wheat).
- Aggregate particles should mainly consist of small loose grains of free-flowing sand and without lumps (dust with particle size < 0.1 mm).

**B.5.1.2.2** The type test required for the sensor should be in accordance with the following:

- The test container for the cargo/water mixture should be dimensioned so that its height and volume are such that the sensor and any filtration fitted can be totally submerged for the repeated functionality tests and the static and dynamic inclination tests.
- The sensor and any filtration fitted that should be submerged and should be arranged in the container as they would be installed in accordance with the installation instructions.
- The pressure in the container for testing the complete detector should be not more than 0.2 bar at the sensor and any filter arrangement. The pressure may be realized by pressurization or by using a container of sufficient height.
- The cargo/water mixture should be pumped into the test container and suitable agitation of the mixture provided to keep the solids in suspension. The effect of pumping the cargo/water mixture into the container should not affect the operation of the sensor and filter arrangements.
- The cargo/water mixture should be pumped into the test container to a predetermined level that submerges the detector and the operation of the alarm observed.
- The test container should then be drained and the deactivation of the alarm condition observed.
- The test container and sensor with any filter arrangement should be allowed to dry without physical intervention.
- The test procedure should be repeated consecutively ten times without cleaning any filter arrangement that may be fitted in accordance with the manufacturer's installation instructions.
- Satisfactory alarm activation and deactivation at each of the 10 consecutive tests will demonstrate satisfactory type testing.

**B.5.1.3** The water pressure testing of the enclosure is to be based on a pressure head held for a period depending on the application:

Section 18 Additional Rules for Bulk Carriers and Single Hold Cargo Ships other than Bulk Carriers

---

- The submerged test period for electrical components intended to be installed in ballast tanks and cargo tanks used as ballast tanks is to be not less than 20 days.
- The submerged test period for electrical components intended to be installed in dry spaces and cargo holds not intended to be used as ballast tanks is to be not less than 24 hours.
- Where a detector and/or cable connecting device (e.g. junction box, etc) is installed in a space adjacent to a cargo hold (e.g. lower stool, etc.) and the space is considered to be flooded under damage stability calculations, the detectors and equipment are to satisfy the requirements of IP68 for a water head equal to the hold depth for a period of 20 days or 24 hours on the basis of whether or not the cargo hold is intended to be used as a ballast tank as described in the previous bullet points.

**B.5.1.4** The equipment manufacturer is to demonstrate the effectiveness and cleaning of any filters/strainers that are fitted to the detector units.

**B.5.2 Tests on board**

After installation a functionality test for each water ingress detection system is to be carried out.

**B.5.2.1** The test shall represent the presence of water at the detectors for every level monitored. Simulation methods may be used where the direct use of water is impracticable.

**B.5.2.2** Each detector alarm shall be tested to verify that the pre-alarm and main alarm levels operate for every space where they are installed and indicate correctly.

**B.5.2.3** The fault monitoring arrangements shall be tested as far as practicable.

**B.5.2.4** Records of testing of the system shall be retained on board.

## Section 19 Additional Rules for Ships with Ice Class

A	Ships with Ice Class.....	19-1
---	---------------------------	------

### A Ships with Ice Class

#### A.1 Electrical installations

**A.1.1** The selection, layout and arrangement of all shipboard machinery, equipment and appliances shall be such as to ensure faultless continuous operation in arctic ice-covered waters. The provision may not be effected of emergency heat and power by interference in the electrical system.

Ships intended for navigation in polar waters may have the ice class notations **PC7 – PC1** affixed to their Character of Classification if the GL [Guidelines for the Construction of Polar Class Ships \(I-1-22\)](#) are complied with.

**A.1.2** Precautions shall be taken to minimize risk of supplies to essential and emergency services being interrupted by the inadvertent or accidental opening of switches or circuit breakers due to vibrations or accelerations during icebreaking operations.

**A.1.3** Emergency power supply for communications equipment provided by battery shall be provided with a means whereby the batteries are protected from extreme low temperatures.

**A.1.4** Emergency power batteries, including those stored in deck boxes shall be secured in a position where excessive movement is prevented during ice-transiting operations and explosive gas ventilation is not restricted by the accumulation of ice or snow.

**A.1.5** Control systems based on computers and other electronic hardware installations necessary for the proper functioning of essential equipment should be designed for redundancy and resistance to vibration, dampness and low humidity.





## Section 20 Electrical Equipment

A	Electrical Machinery.....	20-1
B	Transformers and Reactance Coils .....	20-10
C	Capacitors .....	20-12
D	Storage Batteries, Chargers and Uninterruptible Power Supplies (UPS).....	20-13
E	Switchgear and Protection Devices .....	20-15
F	Cables and Insulated Wires .....	20-16
G	Cable Penetrations and Fire Stops.....	20-18
H	Installation Material .....	20-19
I	Lighting Fixtures.....	20-19
J	Electrical Heating Equipment.....	20-20

### A Electrical Machinery

#### A.1 Generators and motors

Electrical machines shall conform to IEC publication 60034 or an equivalent standard.

For medium-voltage machines, see also [Section 8](#).

##### A.1.1 Materials

Materials for the construction of electrical machines shall conform to the requirements set out in [Section 1, J](#).

For shaft materials, see [A.1.4](#).

##### A.1.2 Degree of protection

Protection against electric shock, accidental contacts and the entry of foreign bodies and water shall conform to [Section 1, K](#). The degree of required protection shall be assured when the equipment is installed and in operation.

##### A.1.3 Ventilation and cooling

**A.1.3.1** The construction of machines with coolants other than air shall be agreed with GL considering the operating conditions.

##### A.1.3.2 Heat exchanger/cooler

Cooling units shall comply with our GL Rules for [Machinery Installations \(I-1-2\), Section 8](#). Cooling units with the operating medium water, a design pressure  $p_c \leq 16$  bar and a design temperature  $t \leq 200$  °C correspond to pressure vessel class III.

##### A.1.3.3 Draught ventilation

The supply air to draught-ventilated machines shall be as far as practicable free of moisture, oil vapours and dust. If required filters shall be provided.

##### A.1.3.4 Enclosed air cooling circuit

Where heat-exchangers are used in the air circuit, they shall be designed and mounted in such a way that condensation- or leakage water from the exchanger system is kept away from the machine windings.

Leakage monitoring is required. The water supply-lines and recirculating lines of each heat-exchanger shall be fitted with shut-off valves. The air ducts shall be provided with inspection holes for visual observation of the heat-exchanger.

A failure of cooling (air filters, fan flaps, forced ventilation, recooling) shall be alarmed, e.g. by monitoring of the cooling air temperature.

Machines for electric propulsion plants shall be equipped with monitoring devices in accordance with [Section 13, H](#).

Machines fitted with brushes shall be ventilated in such direction that fines from the brushes does not enter the inside of the machine.

#### **A.1.3.5 Surface cooling**

Surface-cooled machines on the open deck shall have external fans only if they are fully protected against icing.

#### **A.1.4 Construction of shafts**

The materials for the shafts of

- motors of electric propulsion plants
- main generators supplying the motors of electric propulsion plants
- shaft generators or supplementary electrical drives if their shafts form part of the ship's main shafting

shall conform to the GL Rules for [Principles and Test Procedures \(II-1-1\)](#) and [Machinery Installations \(I-1-2\)](#).

Proof shall take the form of a GL acceptance test certificate, similar as for propeller shafts.

Welds on shafts and rotors shall comply with the GL Rules for Materials and Welding, Part 3 – Welding (II-3).

#### **A.1.5 Bearings and bearing lubrication**

##### **A.1.5.1 Plain bearings**

Bearing shells shall be easily replaceable. Provision shall be made for checking the bearing lubrication. Adequate lubrication shall be assured even in inclined positions in accordance with [Section 1, Table 1.2](#). No oil shall flow out and penetrate into the machine.

In the case of bearings with forced lubrication, failure of the oil supply and the attainment of excessive bearing temperatures shall cause an alarm.

Two-part bearings shall be fitted with thermometers indicating, wherever possible, the temperature of the lower bearing shell.

Turbogenerators and propulsion motors shall be equipped with devices which, in the event of a failure of the normal lubricating oil supply, provide adequate lubrication until the machine has come to standstill.

##### **A.1.5.2 Prevention of bearing currents**

To avoid damage to bearings, it is essential to ensure that no harmful currents can flow between bearing and shaft.

#### **A.1.6 Standstill heating system**

Generators and main propulsion motors with an output  $\geq 500$  kW and all transverse-thruster motors shall be equipped with an electric heating designed to maintain the temperature inside the machine at about 3 K above ambient temperature.

An indicator shall show when the standstill heating system is in operation.

#### **A.1.7 Accessibility for inspection, repairs and maintenance**

Components like commutators, sliprings, carbon brushes and regulators for example shall be accessible for inspection, repairs and maintenance.

For larger machines with plain bearings, provision shall be made for the direct or indirect measurement of the air gap.

### **A.1.8 Windings**

In interaction with the specified protection devices, machines shall be able to withstand the dynamic and thermal stresses likely to result from a short circuit.

Machines shall be designed and rated in such a way that the permissible temperature rises listed in [Table 20.3](#) are not exceeded.

All windings shall be effectively protected against the effects of oil vapours and air laden with moisture or salt.

### **A.1.9 Air gaps**

Machines with only one internal bearing shall have a minimum air gap of 1.5 mm.

Where generators are intended for incorporation in the line shafting, the design of the generator and its foundations shall ensure faultless operation of the propulsion plant even in heavy seas, and regardless of the loading condition of the ship. In consideration of the special service conditions, the generator air gap shall not be less than 6 mm.

### **A.1.10 Brush rocker**

The operation position of the brush rocker shall be clearly marked.

### **A.1.11 Terminal boxes**

Terminal boxes shall be located in accessible positions.

Separate terminal boxes are required for terminals with service voltages above 1000 V AC or 1500 V DC.

Terminals shall be clearly marked.

The degree of protection of terminal boxes shall correspond to that of the machine, but shall in no case be less than IP44 (see [Section 1, K](#)).

### **A.1.12 Voltage regulators**

Regulators shall withstand the loads expected at the place of installation (see [Section 1](#)).

The installation of regulators in terminal boxes is only permitted if the regulator units are mechanically separated so that they cannot be damaged during the mounting of the main cables.

Set point adjusters shall be so designed that shifting of themselves is impossible, and they shall be adjustable from outside by use of a tool only.

### **A.1.13 Operation in network with semiconductor converters**

Electric machines operating in networks containing semiconductor converters shall be designed for the expected harmonics of the system. A sufficient reserve shall be considered for the temperature rise, compared with a sinoidal load.

### **A.1.14 Rating plate**

Machines shall be fitted with durable corrosion-resistant rating plates.

## **A.2 Magnetic brakes**

The requirements stated in [A.1](#) shall be applied correspondingly.

The temperature rise of the windings shall not exceed the permitted values shown in [Table 20.3](#).

Where windings are located in the immediate vicinity of the brake linings, the heat generated during braking shall be considered.

## **A.3 Magnetic clutches**

The requirements stated in [A.1](#) shall be applied correspondingly.

When engaged, the clutch shall take over the drive smoothly and reliably. The clutch shall exert no axial thrust.

#### A.4 Testing of electrical machinery

All electric machines shall be tested at the manufacturer's works.

A works test report shall be prepared covering the tests performed.

The tests shall be performed in accordance with IEC publication 60034-1. GL reserve the right to stipulate additional tests in the case of new types of machines or where it is required for another particular reason.

##### A.4.1 Tests in the presence of a surveyor

The machines listed below are subject to testing in the manufacturer's works in the presence of a Surveyor:

**A.4.1.1** Generators and motors for essential equipment with outputs of 100 kW or kVA and over.

**A.4.1.2** Motors for installations with a class notation such as e.g. **CRS** with an output of 100 kW or more.

**A.4.1.3** The presence of a Surveyor at the tests is not required if the generators and motors have a valid GL Type Approval Certificate in the range of  $\geq 100$  kW/kVA and  $< 300$  kW/kVA.

Generators and Motors  $\geq 300$  kW/kVA are subject to testing in the manufacturer's works in the presence of a Surveyor.

**A.4.1.4** Material test for shafts of:

- motors of electric propulsion plants
- main generators supplying the motors of electric propulsion plants and
- shaft generators or supplementary electrical drives if their shafts form part of the ship's main shafting (see [A.1.4](#) and [Section 13, J](#))

##### A.4.2 Works test reports

On request, works test reports shall be presented for machines not tested in the presence of a Surveyor.

##### A.4.3 Extent of tests

Regarding scope of tests see [Table 20.1](#).

**A.4.3.1** Check of technical documentation and visual inspection

##### A.4.3.2 Measurement of winding resistance

The winding resistances shall be measured and recorded.

##### A.4.3.3 Operational test

The fully assembled machines, including all control and supplementary elements (e.g. winding and bearing temperature sensors, current and voltage transformers), shall undergo operational tests.

Generators shall be tested with their excitation systems.

**Table 20.1 Summary of tests to be carried out**

No.	Tests	AC generators		Motors	
		Type test <sup>1</sup>	Routine test <sup>2</sup>	Type test <sup>1</sup>	Routine test <sup>2</sup>
1	Technical documentation check, visual inspection	×	×	×	×
2	Winding resistance measurement	×	×	×	×
3	Operational test	×	×	×	×
4	Heat run test	×		×	

**Table 20.1 Summary of tests to be carried out (continued)**

No.	Tests	AC generators		Motors	
		Type test <sup>1</sup>	Routine test <sup>2</sup>	Type test <sup>1</sup>	Routine test <sup>2</sup>
5	Load test	×		×	
6	Overload, overcurrent test	×	×	×	×
7	Short circuit test	×			
8	Overspeed test	×	×	×	×
9	Winding test (High-voltage test)	×	×	×	×
10	Insulation resistance measurement	×	×	×	×
11	Degree of protection check	×		×	
12	Bearing check	×	×	×	×
13	Test of voltage regulator, see <a href="#">Section 3, B.2</a> <sup>3</sup>	×	×		

<sup>1</sup> test of the first machine of a series  
<sup>2</sup> test of all other machines of the series  
<sup>3</sup> test together with 5.

**A.4.3.4 Heat test**

- a) A heat test shall be performed until the steady-state temperature corresponding to the required mode of operation is reached. The steady-state temperature pass for reached when the temperature rises by not more than 2 K per hour.

Machines with separate cooling fans, air filters and heat exchangers shall be tested together with this equipment.

The heat run shall be completed with the determination of the temperature rise. The maximum permissible values shown in [Table 20.3](#) shall not be exceeded.

- b) An extrapolation of the measured values to the disconnection time ( $t = 0$ ) is not necessary if the reading takes place within the periods listed in [Table 20.2](#).

**Table 20.2 Time limits for data acquisition**

Rated power [kW/kVA]	Time elapsed after disconnection [s]
up to 50	30
over 50 up to 200	90
over 200 up to 5000	120
over 5000	by agreement

- c) Heat tests on machines of identical construction made not more than 3 years previously can be recognized.

The referenced temperature rise shall be at least 10 % lower than that listed in [Table 20.3](#).

The following tests shall be carried out at approximately normal operating temperatures.

#### **A.4.3.5 Load characteristics**

For generators the voltage, and for motors the speed shall be checked as a function of the load.

#### **A.4.3.6 Overload/overcurrent test**

The overload/overcurrent test shall be performed

- a) for generators at 1.5 times the rated current for two minutes
- b) for shaft generators, which are arranged in the main shafting and – due to their construction - could not be tested in the manufacturer's works, at 1.1 times the rated current for 10 minutes
- c) for motors where no particular assessments are made, at 1.6 times the rated torque for 15 seconds. During the tests the motors shall not deviate substantially from their rated speeds. Three-phase motors shall not pull-out.

The overload test can be replaced a routine test by the overcurrent test.

- d) for anchor windlass motors, at 1.6 times the rated torque for two minutes. Overload tests already performed on motors of identical construction may be recognized.

The current of the operating stage corresponding to twice the rated torque shall be measured and indicated on the rating plate.

- e) The overload/overcurrent test is not necessary, if a GL type test for motors and generators is available.

#### **A.4.3.7 Short-circuit test**

- a) On all synchronous generators, the steady short-circuit current shall be determined with the exciter unit in operation.

With a three-phase short circuit between terminals, the steady short-circuit current shall not be less than three times the rated current. The generator and its exciter unit shall be capable of withstanding the steady short-circuit current for a period of two seconds without suffering damage.

- b) A sudden-short-circuit test may be demanded
  - to determine the reactances
  - if there is any concern regarding mechanical and electrical strength.

Synchronous generators which have undergone a sudden-short-circuit test shall be thoroughly examined after the test for any damage.

#### **A.4.3.8 Overspeed test**

As proof of mechanical strength, a two-minute overspeed test shall be carried out as follows:

- a) for generators with their own drive, at 1.2 times the rated speed
- b) for generators coupled to the main propulsion plant and not arranged in the main shafting, at 1.25 times the rated speed
- c) for shaft generators arranged in the main shafting and whose construction makes testing impracticable, proof by computation of mechanical strength is required
- d) for motors with one nominal speed, at 1.2 times the no-load speed
- e) for variable-speed motors, at 1.2 times the maximum no-load speed
- f) for motors with series characteristics, at 1.2 times the maximum speed shown on the rating plate, but at least at 1.5 times the rated speed

The overspeed test may be dispensed with in the case of squirrel-cage machines.

**Table 20.3 Permitted temperature-rises of air cooled machines at an ambient temperature of 45 °C (difference values in K)**

No.	Machinery component		Method of measurement <sup>3</sup>	Insulation class				
				A	E	B	F <sup>1</sup>	H <sup>1</sup>
1	AC windings of machines		R	55	70	75	100	120
2	Commutator windings		R	55	70	75	100	120
3	Field windings of AC and DC machines with DC excitation, other than those specified under 4		R	55	70	75	100	120
4	a) Field windings of synchronous machines with cylindrical rotors having DC excitation winding, embedded in slots except synchronous induction motors		R	–	–	85	105	125
	b) Stationary field windings of DC machines having more than on layer		R	55	70	75	100	120
	c) Low-resistance field windings of AC and DC machines and compensation windings of DC machines having more than one layer		R Th	55	70	75	95	115
	d) Single-layer field windings of AC and DC machines with exposed bare or varnished metal surfaces and single-layer compensation windings of DC machines		R Th	60	75	85	105	125
5	Permanently short-circuited, insulated windings		Th	55	70	75	95	115
6	Permanently short-circuited, uninsulated windings		The temperature rises of these parts shall in no case reach such values that there is a risk of injury to any insulation or other material on adjacent parts or to the item itself					
7	Iron cores and other parts not in contact with windings							
8	Iron cores and other parts in contact with windings		Th	55	70	75	95	115
9	Commutators and slip rings, open or enclosed		Th	55	65	75	85	105
10	Plain bearings	measured in the lower bearing shell or in the oil sump after shutdown		45				
11	Roller bearings Roller bearings with special grease	measured in the lubrication nipple bore or near the outer bearing seat		45 75				
12	Surface temperature			Reference 35 <sup>2</sup>				
<sup>1</sup> These values may need correction in the case of high-voltage AC windings. <sup>2</sup> Higher temperature rises may be expected on electrical machines with insulation material for high temperatures. Where parts of such machinery may be accidentally touched and there is a risk of burns (> 80 °C), GL reserves the right to request means of protection such as a handrail to prevent accidental contacts. <sup>3</sup> R = resistance method, Th = thermometer method.								

**A.4.3.9 Winding test (high-voltage test)**

a) The test voltage shall be as shown in [Table 20.4](#). It shall be applied for one minute for each single test.

The voltage test shall be carried out between the windings and the machine housing, the machine housing being connected to the windings not in-volved in the test. This test shall be performed only on new, fully assembled machines fitted with all their working parts.

The test voltage shall be a practically sinusoidal AC voltage at system frequency.

The maximum anticipated no-load voltage or the maximum system voltage is to be used as reference in determining the test voltage.

**Table 20.4 Test voltages for the winding test**

No.	Machine or machinery component	Test voltage (r.m.s.) dependent on rated voltage U of the subject winding
1	Insulated windings of rotating machines of output less than 1 kW (kVA), and of rated voltages less than 100 V with the exception of those in items 4 to 8	$2 U + 500 \text{ V}$
2	Insulated windings of rotating machines of size less than 10000 kW (kVA), with the exception of those in item 1 and items 4 to 8	$2 U + 1000 \text{ V}$ , with a minimum of 1500 V
3	Insulated windings of rotating machines of size 10000 kW (kVA) or more with the exception of those in items 4 to 8 rated voltage up to 11000 V	$2 U + 1000 \text{ V}$
4	Separately excited field windings of DC machines	$1000 \text{ V} + \text{twice the maximum excitation voltage}$ but not less than 1500 V
5	Field windings of synchronous generators, synchronous motors and rotary phase converters a) rated field voltage up to 500 V over 500 V When a machine is intended to be started with the field winding short-circuited or connected across a resistance of value less than ten times the resistance of the winding When the machine is intended to be started either with the field winding connected across a resistance of value equal to, or more than, ten times the resistance of the winding, or with the field windings on open-circuit with or without a field dividing switch	10 times rated field voltage, with a minimum of 1500 V $4000 \text{ V} + \text{twice rated field voltage}$ 10 times the rated field voltage, minimum 1500 V, maximum 3500 V  $1000 \text{ V} + \text{twice the maximum value of the r.m.s. voltage, which can occur under the specified starting conditions, between the terminals of the field winding, or in the case of a sectionalized field winding between the terminals of any section, with a minimum of } 1500 \text{ V}$



**Table 20.4 Test voltages for the winding test** (continued)

No.	Machine or machinery component	Test voltage (r.m.s.) dependent on rated voltage U of winding concerned
6	Secondary (usually rotor) windings of induction motors or synchronous induction motors if not permanently short-circuited (e.g. if intended for rheostatic starting  for non-reversing motors or motors reversible from standstill only    for motors to be reversed or braked by reversing the primary supply while the motor is running	1000 V + twice the open-circuit standstill voltage as measured between slip rings or secondary terminals with rated voltage applied to the primary windings    1000 V + four times the open-circuit secondary voltage as defined in item 6a)
7	Exciters (exception below)  Exception 1: Exciters of synchronous motors (including synchronous induction motors) if connected to earth or disconnected from the field windings during starting  Exception 2: Separately excited field windings of exciters	as for the windings to which they are connected  twice rated exciter voltage + 1000 V, with a minimum of 1500 V    as under item 4
8	Assembled group of machines and apparatus	A repetition of the tests in items 1 to 7 above should be avoided if possible, but if a test on an assembled group of several pieces of new machines, each one of which has previously passed its high-voltage test, is made, the test voltage to be applied to such assembled group shall be 80 % of the lowest test voltage appropriate for any part of the group. <sup>1</sup>
<sup>1</sup> Where a number of windings belonging to one or more machines are connected together, the test voltage is dictated by the maximum voltage to earth which can occur.		

- b) Any repetition of the voltage test which may be necessary shall be performed at only 80 % of the nominal test voltage specified in [Table 20.4](#).
- c) Electrical machines with voltage ratings acc. to [Section 8](#) shall be subjected to a lightning impulse withstand voltage test acc. to IEC publication 60034-15. The test shall be carried out for the coils as a random sample test.

**A.4.3.10 Determination of insulation resistance**

The insulation resistance measurement shall be carried out at the end of the test sequence, with the machine at operating temperature, if possible.

Minimum values of the measuring voltage and the insulation resistance shall be taken from [Table 20.5](#).

**Table 20.5 Minimum values for measurement voltage and insulation resistance**

Rated voltage [V]	Measurement voltage [V]	Insulation resistance [MΩ]
$U_n \leq 250$	$2 \times U_n$	1
$250 < U_n \leq 1000$	500	1
$1000 < U_n \leq 7200$	1000	$\frac{U_n}{1000} + 1$
$7200 < U_n \leq 15000$	5000	$\frac{U_n}{1000} + 1$

The maximum anticipated no-load voltage or the maximum system voltage shall be taken for the rated voltage.

**A.4.3.11 Test of degree of protection**

See [Section 1, K](#)

**A.4.3.12 Bearing check**

Plain bearings shall be opened and examined after the test.

**A.4.3.13 Test of voltage regulator**

See [Section 3, B.2](#)

**B Transformers and Reactance Coils**

**B.1 General**

Transformers and Reactance Coils shall conform to IEC publication 60076, Power transformers or an equivalent standard.

For medium - voltage machines, see also [Section 8](#).

**B.1.1 Coolant**

Preferably dry type transformers shall be used on board of ships.

For separately cooled transformers the cooling air shall be monitored

**B.1.2 Windings**

All transformers shall have separate windings for primary and secondary coils, except for starting- and ignition transformers, which may be of the autotransformer type.

**B.2 Rating**

**B.2.1 Voltage variation during loading**

Under resistive load, the voltage variation between no-load and full-load shall not exceed 5 %.

This requirement does not apply to short-circuit-proof transformers.

**B.2.2 Temperature rise**

The temperature rise of windings shall not exceed the values listed in [Table 20.6](#).

Parts of casings with surface temperatures over 80 °C shall be protected against unintentionally contact.

### B.2.3 Short-circuit resistance

Transformers, in co-operation with their protection devices, shall be able to withstand without damage the effects of external short circuits.

### B.3 Rating plate

Transformers shall be provided with a durable corrosion-resistant rating plate.

### B.4 Tests

Transformers shall be tested in the manufacturer's works. Transformers rated with 100 kVA and above shall be tested in the presence of a Surveyor. A works test report covering the tests carried out shall be prepared.

The works test reports shall be presented on request.

Scope of the tests:

#### B.4.1 Heat test

The test shall be performed to determine the temperature rise, which shall not exceed the maximum permissible values shown in [Table 20.6](#).

Temperature-rise tests on transformers of identical construction and carried out not more than 3 years previously may be recognized. The referenced temperature rise shall be 10 % below the values shown in [Table 20.6](#).

**Table 20.6 Permissible temperature rise of transformer- and reactance coil windings with an ambient temperature of 45 °C**

Insulation class	A	E	B	F	H
Temperature rise [K]	55	70	75	95	120

The following tests shall be performed at approximately operating temperature.

#### B.4.2 Induced overvoltage test

The windings shall be tested at twice the rated voltage and at increased frequency to verify that the insulation between turns is sufficient and satisfactory.

The duration of the test shall be

$$120 \text{ s} \cdot \frac{\text{rated frequency}}{\text{test frequency}}$$

but not less than 15 s.

#### B.4.3 Short-circuit test

On request, the short-circuit proof property in accordance with [B.2.3](#) shall be verified.

#### B.4.4 Winding test

The test voltage shown in [Table 20.7](#) shall be applied between the winding parts to be tested and all other windings, which are to be connected to the core and the frame during the test.

The test voltage shall be applied for one minute.

**Table 20.7 Test voltage for transformers and reactance coil windings**

Maximum operating voltage [V]	Alternating withstand voltage [V]
≤ 1000	3000
3600	10000
7200	20000
12000	28000
17500	38000

#### **B.4.5 Determination of insulation resistance**

The measurement of insulation resistance shall be carried out at the end of the test sequence with a DC voltage of at least 500 V.

The insulation resistance shall be at least:

- 5 MΩ between primary and secondary winding
- 2 MΩ for the remaining insulation

## **C Capacitors**

### **C.1 General**

The requirements of this Section apply to power capacitors with a reactive power of 0.5 kVA and above.

### **C.2 Construction**

**C.2.1** Capacitors shall have gastight steel casings.

The metal casings shall have means for the connection of earthing conductors.

The dimensional design of capacitors shall be such that, if a casing is damaged, not more than 10 litres of impregnating agent can leak out.

**C.2.2** Internal faults shall be limited by element fuses.

**C.2.3** Discharge resistors shall ensure the discharge of the capacitor down to a terminal voltage below 50 V within one minute after disconnection.

### **C.3 Testing**

A type-test report shall be submitted for capacitors on request.

### **C.4 Selection and operation**

**C.4.1** The dissipation of heat by convection and radiation shall be ensured. In locations with a high ambient temperature, capacitors of a higher temperature class shall be used.

**C.4.2** The capacitor voltage rating shall be selected in accordance with the operating voltage of the power system, with due regard to a possible voltage increase caused by the capacitor and any inductances in series.

**C.4.3** In systems with high levels of harmonics, capacitors shall be protected against overloading by the use of series inductors and/or the selection of a higher capacitor voltage rating.

**C.4.4** To avoid self-excitation of individually compensated motors, the compensation power shall not exceed 90 % of the no-load reactive power of the motor.

**C.4.5** Reactive power controllers or electrical interlocks are required to avoid overcompensation of the ship's mains.

## **D Storage Batteries, Chargers and Uninterruptible Power Supplies (UPS)**

### **D.1 General**

**D.1.1** These Rules apply to stationary storage batteries and chargers.

#### **D.1.2 Rating of batteries**

Storage batteries shall be so rated that they can supply the consumers for the required period, in accordance with the energy balance, when charged to 80 % of their rated capacity.

At the end of the supply period, the voltage at the battery or at the consumers shall conform as a minimum requirement to the values indicated in [Section 1, F.](#) and [Section 3, C.](#)

#### **D.1.3 References to other rules**

See [Section 2, C](#) and [Section 3](#)

### **D.2 Storage batteries**

**D.2.1** Permitted are lead-acid storage batteries with diluted sulphuric acid as electrolyte and steel batteries with nickel-cadmium cells and diluted potassium hydroxide as electrolyte.

**D.2.2** Other types of storage batteries such as silver/zinc batteries or sealed lead-acid batteries may be permitted, if their suitability for shipboard use is proven.

**D.2.3** Storage batteries shall be so designed that they retain their rated capacity at inclinations of up to 22.5°, and no electrolyte leaks out at inclinations of up to 40°. Cells without covers are not allowed.

**D.2.4** The casing shall be resistant to electrolytes, mineral oils, cleaning agents and to corrosion by saline mist. Glass and readily flammable materials shall not be used for battery casings.

**D.2.5** For storage batteries containing liquid electrolyte it shall be possible to check the electrolyte level. The maximum permissible electrolyte level shall be marked.

**D.2.6** The weight of the greatest transportable unit shall not exceed 100 kg.

**D.2.7** The nominal operating data of storage batteries shall be indicated on rating plates.

**D.2.8** Storage batteries shall be maintained and operated in accordance with the manufacturer's instructions.

### **D.3 Chargers**

**D.3.1** Charger equipment shall be suitable for the type of storage batteries, the required charging characteristic and the selected connection.

**D.3.2** Charging equipment shall be so rated that discharged storage batteries can be charged to 80 % of their rated capacity within a period not greater than 10 hours without exceeding the maximum permissible charging currents.

Only automatic chargers shall be used with charging characteristics adapted to the type of batteries.

**D.3.3** If consumers are simultaneously supplied during charging, the maximum charging voltage shall not exceed the rated voltage described in [Section 1, Table 1.7.](#)

The power demand of the consumers shall be considered for the selection of the chargers.

**D.3.4** Chargers with a charging power above 2 kW shall be tested in presence of a GL-Surveyor.

**D.3.5** Refer to [Section 21, C.2.2 c](#)) regarding tests in the manufacturer's works of battery chargers.

## **D.4 Uninterruptible power supplies (UPS)**

### **D.4.1 General**

**D.4.1.1** These requirements to UPS units apply when providing an alternative power supply or transitional power supply to services as defined in [Section 3, C](#). A UPS unit complying with these requirements may provide an alternative power supply as an accumulator battery in terms of being an independent power supply for services defined in [Section 3, C.3.2.4](#) or [Section 14, C.1.2.3](#).

### **D.4.1.2 Definitions**

#### **D.4.1.2.1 Uninterruptible Power System (UPS)**

Combination of converter, inverter, switches and energy storage means, for example batteries, constituting a power supply system for maintaining continuity of load power in case of input power failure (*IEC publication 62040*)

#### **D.4.1.2.2 Off-line UPS unit**

A UPS unit where under normal operation the output load is powered from the input power supply (via bypass) and only transferred to the inverter if the input power supply fails or goes outside preset limits. This transition will invariably result in a brief break in the load supply.

#### **D.4.1.2.3 On-line UPS unit**

A UPS unit where under normal operation the output load is powered from the inverter, and will therefore continue to operate without break in the event of the power supply input failing or going outside preset limits.

### **D.4.2 Design and construction**

**D.4.2.1** UPS units are to be constructed in accordance with IEC 62040, or an acceptable and relevant national or international standard. Battery ventilation shall be designed in accordance with [Section 2, C](#).

**D.4.2.2** The operation of the UPS is not to depend upon external services.

**D.4.2.3** The type of UPS unit employed, whether off-line or on-line, is to be appropriate to the power supply requirements of the connected load equipment.

**D.4.2.4** A bypass or a second UPS in parallel is to be provided.

**D.4.2.5** The UPS unit is to be monitored. An audible and visual alarm is to be given on the ship's alarm system for

- power supply failure (voltage and frequency) to the connected load,
- earth fault, if applicable,
- operation of battery protective device,
- when the battery is being discharged, and
- when the UPS is not operating under normal condition.

### **D.4.3 Performance**

**D.4.3.1** The output power is to be maintained for the duration required for the connected equipment as stated in [Section 3, C](#).

**D.4.3.2** No additional circuits are to be connected to the UPS unit without verification that the UPS unit has adequate capacity. The UPS battery capacity is, at all times, to be capable of supplying the designated loads for the time specified in [Section 3, C](#).

**D.4.3.3** On restoration of the input power supply, the rating of the charge unit shall be sufficient to recharge the batteries while maintaining the output supply to the load equipment.

## **E Switchgear and Protection Devices**

### **E.1 General**

**E.1.1** Switchgear and protection devices shall conform to IEC publications or to another standard recognized by GL.

**E.1.2** For materials and insulation, see [Section 1, J](#).

**E.1.3** For equipment and components subject to mandatory type-approval, see [Section 5, H](#) and [D](#), and [E](#).

### **E.2 Medium-voltage switchgear**

For details of medium-voltage switchgear, see [Section 8](#).

### **E.3 Low-voltage switchgear**

#### **E.3.1 Circuit breakers**

##### **E.3.1.1 Drives**

- a) Power-driven circuit-breakers shall be equipped with an additional emergency drive for hand-operation.
- b) Mechanical actuating elements on circuit-breakers for generators and essential circuits shall be so connected to the circuit-breakers that they cannot be lost.
- c) Circuit-breakers with a making capacity exceeding 10 kA shall be equipped with a drive which performs the closing operation independently of the actuating force and speed (by snap action).
- d) If the conditions for the closing operation are not fulfilled (e.g. undervoltage release not energized), switching-on shall not cause the contact pieces to come into contact.

##### **E.3.1.2 Making and breaking capacity**

The making and breaking capacity shall be tested in accordance with IEC publication 60947-2. Other standards may be recognized.

### **E.4 Protection devices**

#### **E.4.1 Short-circuit protection**

Short-circuit protection devices shall be independent of energy supplied from other circuits than those to be protected. In the event of a short circuit, the total break-down of the supply voltage shall be expected.

Short-circuit protection devices for generators shall be equipped with reclosing inhibitors, and shall be delayed for selective disconnection.

#### **E.4.2 Overcurrent protection**

The operation of overcurrent relays shall not be influenced by the ambient temperature. Thermal bimetallic relays shall be temperature compensated.

Overcurrent relays for motor protection shall be adjustable and provided with a reclosing inhibitor.

#### **E.4.3 Undervoltage protection**

Undervoltage relays shall cause the circuit-breaker to open if the voltage drops to 70 % - 35 % of the rated voltage. Undervoltage relays of generator circuit-breakers shall have a delay up to 500 ms.

#### **E.4.4 Shunt trips**

Shunt trips shall ensure the disconnection of the circuit-breakers even if the voltage drops to 85 % of the rated voltage.

#### **E.4.5 Electronic protection devices**

Electronic protection devices shall remain operative at their maximum permissible load at an ambient temperature of 55 °C.

#### **E.4.6 Reverse power protection**

The reverse power protection device shall respond to the active power regardless of the power factor, and shall operate only in the event of reverse power.

The response value and pick up time shall be adjustable.

The reverse power protection device shall remain operative despite a voltage drop to 50 % of the rated value.

#### **E.4.7 Phase failure protection**

Protection devices for detection of a single-phase failure in three-phase circuits shall operate instantaneously. Bimetallic relays with differential release do not constitute phase failure protection devices in the opinion of these Rules.

#### **E.4.8 Check synchronizers**

Check synchronizers for the protection of an alternator against parallel connection at an unacceptable phase angle shall allow parallel switching only up to an angular deviation (electrical) of 45° and up to a frequency difference of 1 Hz.

The check synchronizer shall ensure that parallel switching is impossible if the supply- or measuring voltage fails or in the event of failure of any component.

#### **E.4.9 Insulation monitoring equipment**

Devices for insulation monitoring of ships mains shall continuously monitor the insulation resistance of the network, and shall release an alarm should the insulation resistance of the system fall below 50 ohms per volt of the operating voltage.

The measuring current shall not exceed 30 mA in the event of a dead short circuit to earth.

### **E.5 Manual emergency stop**

**E.5.1** Manual emergency stops are to be protected against unintentional activation.

**E.5.2** The manual emergency stop shall not be automatically cancelled.

**E.5.3** It shall be recognizable which manual emergency stop has been activated.

## **F Cables and Insulated Wires**

### **F.1 General**

**F.1.1** Cables and wires shall be flame-retardant and self-extinguishing.

**F.1.2** If cable- and wire types have passed a bundle fire test to IEC publication 60332-3, category A/F or IEEE 45.-18.13.5, the installation of fire stops is dispensed with when laying in bundles (see also [Section 12, D.14](#) and **SOLAS**, Chapter II-1, Part D, Rule 45.5.2).

**F.1.3** Where fireproof cables shall be used, it is permitted to use cables with retention of insulating capability in accordance with IEC publication 60331 (see also [Section 12, D.15](#)).



**F.1.4** Cables manufactured in accordance with the relevant recommendations of IEC publication 60092-350, 60092-352, 60092-353, 60092-354, 60092-360 and 60092-376 will be accepted by GL provided that they are tested to its satisfaction.

Cables manufactured and tested to standards other than those specified like above-mentioned will be accepted provided they are in accordance with an acceptable and relevant international or national standard.

## **F.2 Conductor material and -structure**

**F.2.1** Electrolytic copper with a resistivity not exceeding  $17.241 \Omega \text{ mm}^2/\text{km}$  at  $20 \text{ }^\circ\text{C}$  shall be used as the material for the conductors of cables and wires.

**F.2.2** If the insulation consists of natural- or synthetic rubber vulcanized with sulphur, the individual conductor wires shall be tinned.

**F.2.3** The conductors of movable wires shall be finely stranded.

The conductors of permanently laid cables and wires shall be made of stranded copper conductors (class 2) or flexible stranded copper conductors (class 5).

Solid conductors up to  $4 \text{ mm}^2$  in cross-section are permitted for final subcircuits of room lighting and space heating systems in the accommodation and for special cables of TV and multimedia applications.

## **F.3 Materials and wall thickness of insulating covers**

**F.3.1** The materials used for insulation shall be of standardized types for which the maximum permissible temperatures at the conductors during undisturbed operation are specified.

## **F.4 Protective coverings, sheaths and braids**

**F.4.1** Single-core cables shall have a suitable separating layer of filler material or foil over the core insulation.

**F.4.2** Multicore cables shall have a common core covering made of filler material or shall have a wrapping and sheath.

**F.4.3** Only materials of a standardized type shall be used for non-metallic sheaths. In all cases the thermal stability of the compounds used shall correspond to that of the insulating material.

**F.4.4** Braids shall be made of corrosion-resistant material such as copper or copper alloy or of material treated to prevent corrosion, e.g. galvanized steel.

**F.4.5** Outer metallic wire braids shall have a coating of protective paint, which shall be lead-free and flame-retardant. The paint shall be of sufficiently low viscosity when applied to enable it to penetrate readily into the wire braid. When dry, it shall not flake off when the cable is bent around a mandrel with a diameter of 15 times that of the cable.

## **F.5 Identification**

**F.5.1** Each cable shall be marked for type and for name of the manufacturer.

**F.5.2** The cores of multicore cables and wires shall have a permanent marking. In multicore cables and wires where the cores are arranged in a number of concentric layers, two adjacent cores in each layer shall be coloured differently from each other and from all other cores, unless the individual cores are otherwise unambiguously identified, e.g. by printed numbers.

**F.5.3** Protective earth conductors shall have green/yellow colour coding.

## **F.6 Approvals**

**F.6.1** Cables and wires are subject to mandatory type approval by GL.

**F.6.2** Proof is required by the manufacturer by issue of workshop test reports stating that the continuous production is made in conformity to relevant standards and is verified by individual and sample tests for each production length of cables. These reports shall record any deviations from the standards.

**F.6.3** The application of cables and wires without type-test is subject to an agreement with GL in every case. Individual and sample tests performed at the manufacturer's works on each lengths delivered are required for these cables (see [F.7.3](#)).

## **F.7 Tests**

**F.7.1** Type tests shall be carried out in accordance with the relevant standards in the manufacturer's works and in the presence of a staff member of the Head Office. The scope of the tests shall be agreed with GL.

**F.7.2** If not specified in the standards, the following tests shall be performed as an additional requirement:

Ozone tests on cable sheaths whose basic material consists of natural- or synthetic rubber. Test conditions shall be:

Ozone concentration : 250 - 300 ppm

Temperature :  $(25 \pm 2)$  °C

Duration : 24 h

The test shall be carried out in accordance with IEC publication 60811-2-1.

Other equivalent test methods may be agreed with GL.

The test is passed satisfactory if no cracks will be discovered visible to the naked eye.

**F.7.3** Individual tests on non-type-tested cables and wires shall be performed in the manufacturer's works in the presence of a Surveyor.

The scope of the tests shall be agreed with GL in advance.

The following tests shall be carried out at least:

- conductor resistance
- dielectric strength
- insulation resistance
- dimensions and construction of samples
- mechanical strength characteristics of samples

## **G Cable Penetrations and Fire Stops**

### **G.1 Bulkhead- and deck penetrations**

**G.1.1** The sealing compounds- and packing systems shall be type-tested by GL.

**G.1.2** The requirements for bulkhead- and deck penetrations are stated in [Section 12, D.8](#).

**G.1.3** The type test shall be performed in the presence of a staff member of the Head Office in the manufacturer's works or in independent institutions, according to the GL Guidelines for [Test Requirements for Sealing Systems of Bulkhead and Deck Penetrations \(VI-7-4\)](#).

### **G.2 Fire stops**

**G.2.1** The requirements for fire stops using partitions or coatings are listed in [Section 12, D.14](#).

**G.2.2** The construction of fire stops using coatings is subject to a type test in the presence of a staff member of the Head Office in the manufacturer's works or in independent institutions.

The test requirements shall be agreed with GL.

## H Installation Material

### H.1 General

**H.1.1** The installation material shall conform to IEC Publications. Other standards may be recognized by GL.

**H.1.2** It is necessary to ensure that terminals are suitable for the connection of stranded conductors. Exceptions are permitted for systems with solid conductors (e.g. lighting, socket-outlets and heating appliances in the accommodation area).

**H.1.3** For materials, see [Section 1, J](#)

### H.2 Plug-and-socket connections

**H.2.1** Depending on their application, the design of plug-and-socket connections shall conform to the following regulations:

- in the accommodation area, day rooms and service rooms (up to 16 A, 250 V AC) - IEC publication 60083 or 60320
- power circuits (up to 250 A, 690 V AC) - IEC publication 60309-1 and 60309-2
- electronic switchgear - IEC publications, e.g. 60130 and 60603
- refrigerated containers - ISO 1496-2

## I Lighting Fixtures

### I.1 General

Luminaires, floodlights and searchlights shall conform to IEC publications 60598 and 60092-306. Other standards may be recognized by GL.

The requirements stated in [H.1](#) shall be observed.

### I.2 Design

**I.2.1** The surface temperature of easily touchable parts of lighting fixtures shall not exceed 60 °C.

**I.2.2** High-power lights with higher surface temperatures shall be protected against unintentional contact by additional means.

**I.2.3** Lighting fittings shall be so arranged as to prevent temperature rises which could damage the cables and wiring, and to prevent surrounding material from becoming excessively hot.

**I.2.4** The terminals and spaces for the connection of cables shall not reach a higher temperature permissible for the insulation of the wires or cables used. The temperature rise in the terminal box shall not exceed 40 K.

**I.2.5** All metal parts of a lighting fixture shall be bounded together.

**I.2.6** Wiring inside lighting fixtures shall have a minimum cross-section of 0.75 mm<sup>2</sup>. A cross-section of at least 1.5 mm<sup>2</sup> shall be used for through wiring.

Heat-resistant wires shall be used for internal wiring.

**I.2.7** Each lighting fixture shall be durably marked with the following details:

- maximum permitted lamp wattage
- minimum mounting distance

## **J Electrical Heating Equipment**

### **J.1 General**

**J.1.1** Electrical heating equipment and boilers shall conform to IEC publications, e.g. 60335, with particular attention to IEC publication 60092-307. In addition the general assignments in [H.1](#) shall be observed.

**J.1.2** The connections of power supply cables shall be so arranged that temperatures higher than permitted for the terminals and supply cables do not arise.

**J.1.3** Controls in operation such as switch knobs and -handles shall not attain temperatures higher than

- 55 °C for metal parts or
- 65 °C for parts made of porcelain, glass, moulded plastics or wood.

A temperature of 5 °C higher is permissible for parts operated by finger tipping only.

**J.1.4** Only heating elements with shrouding or ceramic-embedded heating coils shall be used. Infra-red radiators are permitted.

### **J.2 Design**

#### **J.2.1 Space heaters**

**J.2.1.1** The casing or enclosure of each heater shall be so designed that no objects can be placed on it, and the air can circulate freely around the heating elements.

**J.2.1.2** Electrical space heaters shall be so designed that, based at an ambient temperature of 20 °C, the temperature of the casing or enclosure and of the air flow from the heater does not exceed 95 °C under defined test conditions.

**J.2.1.3** To prevent unacceptable temperature rises due to heat accumulation, each heater shall be fitted with a safety temperature limiter. Automatic reconnection is not permitted.

The safety temperature limiter may be dispensed with for watertight heaters in spaces without a substantial fire risk, e.g. in bathrooms and washing rooms.

**J.2.1.4** The operating switches shall disconnect all live conductors. The switch positions shall be clearly marked at the switches.

#### **J.2.2 Passage heaters and boilers**

Passage heaters and boilers shall be equipped with two mutually independent thermal protection devices, one of them shall be a permanently set safety temperature limiter, the other may be a thermostatic controller.

Automatic reconnection of the safety temperature limiter is not permitted.

#### **J.2.3 Electric ranges and cooking facilities**

**J.2.3.1** Only enclosed-type hot plates shall be used. It shall not be possible for liquids to penetrate into the electrical equipment.

**J.2.3.2** The switches for the individual plates and heating elements shall disconnect all live conductors. The switch steps shall be clearly marked.

**J.2.3.3** Internal connections shall be made of heat-proof terminals and wiring, and shall be corrosion-resistant.

#### **J.2.4 Deep-fat cooking equipment**

Deep-fat cooking equipment shall be fitted with the following arrangements:

- an automatic or manual fire-extinguishing system tested to an international standard <sup>1</sup>
- a primary and backup thermostat with an alarm to alert the operator in the event of failure of either thermostat
- arrangements for automatically shutting off the electrical power upon activation of the fire extinguishing system
- an alarm for indicating operation of the fire-extinguishing system in the galley where the equipment is installed
- controls for manual operation of the fire extinguishing system which are clearly labelled for ready use by the crew

---

<sup>1</sup> Reference ISO 15371:2000 "Fire-extinguishing systems for protection of galley deep-fat cooking equipment"



## Section 21 Tests

A	General .....	21-1
B	Examinations of Technical Documentation.....	21-1
C	Tests in the Manufacturer's Works .....	21-2
D	Tests on Board.....	21-3
E	Type Approvals .....	21-5

### A General

**A.1** The following Rules apply to the testing of electrical and electronic installations, equipment and components.

**A.2** Within the framework of their general quality assurance programme, manufacturers shall ensure that the products they manufacture conform to the specified requirements.

Records shall be made, containing quality-assurance measures and tests and shall be handed over to GL on request.

**A.3** For certain installations, equipment and components, testing is required in the presence of a Surveyor to GL according to these Rules, see [C](#), [D](#) and [E](#).

The tests and items for testing specified below constitute minimum requirements.

GL reserve the right to demand that tests also be performed on other items, either on board or in the manufacturer's works.

**A.4** For appliances of a new type or for equipment which is being used for the first time on ships with GL class, additional tests and trials are to be agreed between the manufacturer and GL, if the circumstances this require.

**A.5** It is the aim of the tests to verify conformity with the requirements covered by the Rules for Construction, and to prove the suitability of equipment for its particular application.

**A.6** Tests are divided into

- examinations of the technical documentation, see [B](#)
- tests in the manufacturer's works, see [C](#)
- tests on board, see [D](#)
- tests for type approvals, see [E](#)

### B Examinations of Technical Documentation

**B.1** The list of documents subject to approval is specified in [Section 1, C](#)

**B.2** The documents which have been examined and approved shall be presented to the Surveyor on request.

## **C Tests in the Manufacturer's Works**

### **C.1 Tests in the presence of a GL Surveyor**

**C.1.1** The tests shall be carried out on the basis of the Rules for Construction and the approved documents. They shall be performed in accordance with a recognized standard.

**C.1.2** Machines, appliances and installations subject to testing in accordance with 2 are to be tested in the presence of a GL surveyor unless the preconditions for one's own responsibility tests by the manufacturer are fulfilled, see [C.3](#).

### **C.2 Machines, appliances and installations subject to testing**

#### **C.2.1 Electrical machines: for scope of tests, see Section 20, A**

- a) Generators and motors for electric propulsion plants
- b) Generators and motors for essential equipment, or if they are necessary for the preservation of the cargo/ship's safety, e.g. for class notation **CRS**, **RCP**, compressors for gas tanker, circulating pumps for sea operation etc.

$P \geq 100 \text{ kW/ kVA}$

- c) Transformers  $P \geq 100 \text{ kVA}$
- d) Autotransformers  $P \geq 100 \text{ kVA}$

#### **C.2.2 Power electronics**

For scope of tests, see [Section 6, G](#).

- a) For electric propulsion plants, see [Section 13, K](#)
- b) For essential equipment  $P \geq 50 \text{ kW/ kVA}$
- c) For battery charging  $P \geq 2 \text{ kW}$

#### **C.2.3 Switchboards**

For scope of tests see [Section 5, F](#) and [Section 8, E](#) and check list form F 217.

- a) Main switchboards
- b) emergency switchboards
- c) switchboards for electric propulsion plants
- d) switchboards for operation of equipment with class notation, e.g. cargo-refrigerating systems **CRS**
- e) distribution switchboards with connected power  $\geq 500 \text{ kW}$
- f) starters for motors in accordance with [C.2.1b](#))

#### **C.2.4 Steamboilers and thermal oil systems**

Scope of tests, see [Section 5, H](#).

#### **C.2.5 Electrical propulsion plants**

Scope of tests, see [Section 13](#).

#### **C.2.6 Computer systems**

Scope of tests, see [Section 10](#).

### **C.3 One's own-responsibility tests made by the manufacturers**

**C.3.1** The products under [C.2.1 b\), c\), d\)](#), [C.2.2 b\), c\)](#) and [C.2.3 d\), e\), f\)](#) may be tested on the manufacturer's own responsibility if the following preconditions are fulfilled:

- A QM system recognized by GL is available.
- GL has carried out type tests of the products.



- The one's-own responsibility tests have been agreed with GL.

**C.3.2** Reference is made to the GL [Guidelines for the Inspection of Mechanical and Electrotechnical Products \(VI-6-2\)](#).

## D Tests on Board

### D.1 General

The tests are divided into

- tests during construction/installation
- tests during dock trials
- tests during sea trials.

### D.2 Tests during construction

**D.2.1** During the period of construction of the ship, the installations shall be checked for conformity with the documents approved by GL and with the Rules for Construction.

**D.2.2** Test certificates for tests which have already been performed shall be presented to the Surveyor on request.

**D.2.3** Protective measures shall be checked:

- a) protection against foreign bodies and water
- b) protection against electric shock, such as protective earthing, protective separation or other measures as listed in [Section 1](#)
- c) measures of explosion protection. The design shall conform to the details on form F 184 "Details about the construction of electrical equipment in hazardous areas", submitted by the shipyard for approval.

### D.2.4 Testing of the cable network

Inspection and testing of cable installation and cable routing with regard to

- a) acceptability of cable routing with regard to
  - separation of cable routes
  - fire safety
  - the reliable supply of emergency consumers
- b) selection and fixation of cables
- c) construction of watertight and fireproof bulkhead and deck penetrations
- d) insulation resistance measurement
- e) for medium-voltage installations, see [Section 8](#)

### D.3 Tests during dock trials

#### D.3.1 General

Proofs are required of the satisfactory condition and proper operation of the main and emergency power supply systems, the steering gear and the aids of manoeuvring, as well as of all the other installations specified in the Rules for Construction.

Unless already required in the Rules for Construction, the tests to be performed shall be agreed with the Surveyor to GL in accordance with the specific characteristics of the subject equipment.

### **D.3.2 Generators**

**D.3.2.1** A test run of the generator sets and as far as possible of the shaft generators shall be conducted under normal operating conditions, and shall be reported on form F 218.

**D.3.2.2** For ships, where electrical power is necessary to restore propulsion, it shall be proved that after black-out and dead ship condition (see [Section 3, B.1.7](#) and [D.1.8](#) together with [C.1.4](#)) the propulsion to the ship in conjunction with required machinery can be restored within 30 min. after black-out.

### **D.3.3 Storage batteries**

The following shall be tested:

- a) installation of storage batteries
- b) ventilation of battery rooms and boxes, and cross-sections of ventilation ducts
- c) storage-battery charging equipment
- d) the required caution labels and information plates

### **D.3.4 Switchgear**

The following items shall be tested under observance of forms F 217 and F 218:

- a) accessibility for operation and maintenance
- b) protection against the ingress of water and oil from ducts and pipes in the vicinity of the switchboards, and sufficient ventilation
- c) equipment of main and emergency switchboards with insulated handrails, gratings and insulating floor coverings
- d) correct settings and operation of protection devices and interlocks
- e) independent manual operation of generating sets from common external voltage and automation systems (manual operation means local start/ stop and speed setting as well as voltage control, protection devices and synchronizing from switchboard)

GL reserves the right to demand the proof of selective arrangement of the ship supply system.

### **D.3.5 Power electronics**

The following items shall be tested:

- a) ventilation of the place of installation
- b) function of the equipment and protection devices

### **D.3.6 Power plants**

The following items shall be tested:

- a) Motor drives together with the driven machines, which shall, wherever possible, be subjected to the most severe anticipated operating conditions. This test shall include a check of the settings of the motors' short-circuit and overcurrent protection devices.
- b) the emergency remote shutdowns (see [Section 4, I.8](#)) of equipment such as
  - engine room fans
  - fuel pumps
  - separators
  - boiler blowers, etc.
- c) closed loop controls, open loop controls and all electric safety devices.

### **D.3.7 Control, monitoring and ship's safety systems**

For these systems operational tests shall be performed.

### **D.3.8 Electrical propulsion plants**

Regarding scope of tests see [Section 13](#).

### **D.3.9 Computer systems**

Regarding scope of tests see [Section 10](#).

## **D.4 Tests during the sea trial**

### **D.4.1 Rating of the main- and emergency electrical power supplies**

During the sea trial it shall be proved that the main and emergency electrical power supplies are adequately rated and conform to [Section 3](#) and all control and monitoring devices are functioning according to their assignments.

### **D.4.2 Operating reliability during navigation**

**D.4.2.1** Tests shall be carried out to determine whether all the machines, equipment, etc. constituting the electrical installation operate satisfactorily at all revolutions of the main engine, particularly during engine and steering gear manoeuvres.

**D.4.2.2** Tests shall be carried out on the restoration of the main and emergency electrical power supplies following a black-out during navigation.

**D.4.2.3** Tests shall be made of network quality in distribution systems supplied by semiconductor converters and in distribution systems with prevailing load consumption by semiconductor converters.

### **D.4.2.4 Electrical propulsion plants**

Regarding scope of tests see [Section 13](#).

## **E Type Approvals**

**E.1** The installations, equipment and assemblies mentioned in [E.5](#) are subject to mandatory type approval.

For Ships under European flag the “Directive 96/98/EC on marine equipment (MED)”, as amended from time to time, has to be observed.

**E.2** Type approvals shall be coordinated by staff members of the Head Office and executed either in the manufacturer's works or, by agreement, in suitable institutes.

**E.3** Type approvals are carried out according to the GL Guidelines for the Performance of Type Approvals (VI-7) and defined standards.

**E.4** Type tested installations, apparatuses and assemblies shall be used within the scope of valid Construction Rules only. The suitability for the subject application shall be ensured.

### **E.5 Installations, apparatuses and assemblies subject to type testing**

#### **E.5.1 Electrical installations**

##### **E.5.1.1 Cables and accessories**

- a) Cables and insulated wires
- b) Sealing compound and packing systems for bulkhead- and deck penetrations
- c) Busbar trunking systems for the installation
- d) Cable trays/protective casings made of plastic materials are to be type tested in accordance with IACS UR E 16; see [Section 12, D.6](#)

For guidance on testing, refer to IACS REC 73.

**E.5.1.2** Switchgear, see [Section 5, H](#).

Section 21 Tests

---

- a) Circuit-breakers, load switches, disconnect switches and fuses for direct connection to the main busbars or non-protected distribution busbars of main, emergency and propulsion switchboards
- b) Standardized switchgear units manufactured in series with reduced clearance- and creepage distances, see [Section 5, F.3.2](#)

**E.5.1.3** Generator- / mains supply protection devices, see [Section 4, A](#)

- a) Short-circuit protection
- b) Overcurrent protection
- c) Reverse-power protection
- d) Automatically synchronizing device
- e) Underfrequency protection
- f) Over- and undervoltage protection
- g) Differential protection
- h) Earth fault monitoring

**E.5.2** For steering gear and rudder-propeller systems see [Section 7, A](#)

**E.5.2.1** Input devices such as

- a) Phase failure relays
- b) Level sensors

**E.5.2.2** Steering gear control systems with all components important for the function, e.g.

- a) Steering mode selector switch
- b) Follow up/ non follow up control devices

**E.5.3** Variable pitch propeller controls with all components important for the functioning.

**E.5.4** Machinery control systems, see [Section 9](#).

- a) Open and closed loop control for speed and power of internal combustion engines (main and auxiliary engines) and electrical actuators, see also [Section 9, B.9](#)
- b) Safety devices
- c) Safety systems

**E.5.5** Ship's control and safety systems, see [Section 9, C and D](#) and [Section 7, G](#)

- a) Fire detection- and alarm systems
- b) Suction-type smoke-detection systems
- c) Loading instrument (loading computer, see the GL Rules for [Hull Structures \(I-1-1\)](#), [Section 5, A](#)
- d) Automatic stop devices and control units for heel compensation systems, see [Section 7, G](#)
- e) Flame detectors, remotely controlled valves, control electronics and fire detection systems for fixed water-based local application fire-fighting systems (FWBLAFFS, see [Section 9, D](#))
- f) Combustion engine crankcase oil mist detection monitoring device/system

**E.5.6** For tankers see [Section 15](#).

- a) Tank level gauging equipment
- b) Tank level alarm equipment
- c) Overfill protection devices
- d) Tank pressure monitoring systems
- e) Required gas detectors and -systems

**E.5.7** Water ingress detection system for bulk carriers, see [Section 18](#).

**E.5.8** For ships with **CRS** Class Notation see the GL Rules for [Refrigerating Installations \(I-1-10\)](#).

#### Input devices and actuators

**E.5.9** Electrically supplied LLL-systems.

**E.5.10** Computer systems, see [Section 10](#).

**E.5.11** Installations, applied by the GL Rules for Construction for automated and/or remotely controlled systems, see the GL Rules for [Automation \(I-1-4\)](#), [Section 7, E](#).

**E.5.12** Monitoring-, protection- and management systems of battery systems, according to [Section 2, C.2](#).

#### **E.6 Exceptions**

**E.6.1** Instead of the stipulated type approvals in well-founded cases routine tests in the presence of a Surveyor to GL may be carried out. An agreement with GL prior to testing is required.

**E.6.2** Individual tests for cables and wires are specified in [Section 20, F](#).



## Section 22 Spare Parts

**A.1** In order to be able to restore machinery operation and manoeuvring capability of the ship in the event of a damage at sea spare parts for the main propulsion plant and the essential equipment shall be available aboard of each ship together with the necessary tools.

**A.2** The amount of spare parts shall be documented and a corresponding list shall be carried aboard.

