

CHAPTER 6

REFRIGERATION

Learning Objective: Describe the stages of heat theory and the principles involved in heat transfer, and recognize various components of refrigeration systems and their application. Recognize the characteristics and procedures required to service and troubleshoot refrigeration systems.

Modern refrigeration has many applications, such as preserving medicine, blood, and the most important application, the preservation of food. Most foods kept at room temperature spoil rapidly. This is due to the rapid growth of bacteria. Refrigeration preserves food by keeping it cold, which greatly slows down the growth of bacteria. In days past, blocks of ice were used in iceboxes to refrigerate food and other items. These iceboxes were small and not very practical. Today, mechanical refrigeration systems make transportation, storage, and use of refrigerated goods easy and practical.

The installation, operation, adjustment, and repair of refrigeration equipment are the primary responsibility of the Utilitiesman rating. To perform these duties required of a refrigeration mechanic, you need to understand the principles and theory of refrigeration and recognize system components and understand the way they work within the system.

Methods of installing, maintaining, and repairing refrigeration equipment and maintaining, servicing, and repairing domestic refrigerators and freezers are also covered in this chapter.

HEAT AND REFRIGERATION PRINCIPLES

Learning Objective: Explain the basics of heat theory and the basic principles of refrigeration.

REFRIGERATION is the process of removing heat from an area or a substance and is usually done by an artificial means of lowering the temperature, such as the use of ice or mechanical refrigeration. MECHANICAL REFRIGERATION is defined as a mechanical system or apparatus so designed and constructed that, through its function, heat is transferred from one substance to another. Since refrigeration deals entirely with the removal or transfer

of heat, some knowledge of the nature and effects of heat is necessary for a clear understanding of the subject.

NATURE OF HEAT

Heat is a form of energy contained to some extent in every substance on earth. All known elements are made up of very small particles, known as atoms, which, when joined together, form molecules. These molecules are particular to the form they represent. For example, carbon and hydrogen in certain combinations form sugar and in others form alcohol.

Molecules are in a constant state of motion. Heat is a form of molecular energy that results from the motion of these molecules. The temperature of the molecules dictates to a degree the molecular activity within a substance. For this reason, substances exist in three different states or forms—solid, liquid, and gas. Water, for example, may exist in any one of these states. As ice, it is a solid; as water, it is a liquid; and as steam, it is a gas (vapor).

When heat is added to a substance, the rate of molecular motion increases, causing the substance to change from a solid to a liquid, and then to a gas (vapor). For example, in a cube of ice, molecular motion is slow, but as heat is added, molecular activity increases, changing the solid "ice" to a liquid "water" (fig. 6-1). Further application of heat forces the molecules to greater separation and speeds up their motion so that the water changes to steam. The steam formed no longer has a definite volume, such as a solid or liquid has, but expands and fills whatever space is provided for it.

Heat cannot be destroyed or lost. However, it can be transferred from one body or substance to another or to another form of energy. Since heat is not in itself a substance, it can best be considered in relation to its

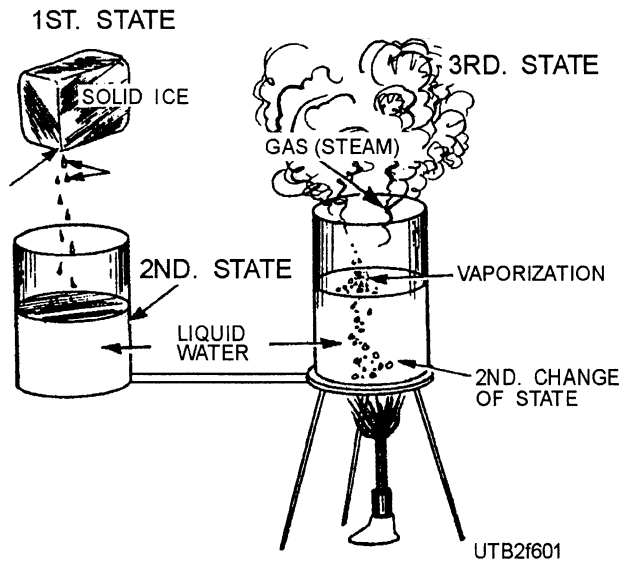

Figure 6-1.—The three states of matter.

effect on substances or bodies. When a body or substance is stated to be cold, the heat that it contains is less concentrated or less intense than the heat in some warmer body or substance used for comparison.

UNITS OF HEAT

In the theory of heat, the speed of the molecules indicates the temperature or intensity of heat, while the number of molecules of a substance indicates the quantity of heat.

The intensity and quantity of heat may be explained in the following simple way. The water in a quart jar and in a 10-gallon container may have the same intensity or temperature, but the quantity of heat required to raise these amounts of water to a higher uniform temperature (from their present uniform temperature) will differ greatly. The 10 gallons of water will absorb a greater amount of heat than the quart jar of water.

The amount of heat added to, or subtracted from, a body can best be measured by the rise or fall in temperature of a known weight of a substance. The standard unit of heat measure is the amount of heat necessary to raise the temperature of 1 pound of water 1°F at sea level when the water temperature is between 32°F and 212°F. Conversely, it is also the amount of heat that must be extracted to lower by 1°F the temperature of a pound of water between the same temperature limits. This unit of heat is called a British

thermal unit (Btu). The Btu's equivalent in the metric system is the calorie, which is the amount of heat required to raise one gram of water 1° Celsius.

Suppose that the temperature of 2 pounds of water was raised from 35°F to 165°F. To find the number of Btu required to increase the temperature, subtract 35 from 165. This equals a 130° temperature rise for 1 pound of water. Since 2 pounds of water were heated, multiply 130 by 2, which equals 260 Btu required to raise 2 pounds of water from 35°F to 165°F.

MEASUREMENT OF HEAT

The usual means of measuring temperature is a thermometer. It measures the degree or intensity of heat and usually consists of a glass tube with a bulb at the lower portion of the tube that contains mercury, colored alcohol, or a volatile liquid. The nature of these liquids causes them to rise or fall uniformly in the hollow tube with each degree in temperature change. Thermometers are used to calibrate the controls of refrigeration. The two most common thermometer scales are the Fahrenheit and the Celsius.

On the Fahrenheit scale, there is a difference of 180° between freezing (32°) and the boiling point (212°) of water. On the Celsius scale, you have only 100° difference between the same points (0° freezing and 100° boiling point).

Of course, a Celsius reading can be converted to a Fahrenheit reading, or vice versa. This can be expressed in terms of the following formula:

$$F = (C \times 1.8) + 32$$

To change Fahrenheit to a Celsius reading, the terms of the formula are as follows:

$$C = (F - 32) \div 1.8$$

TRANSFER OF HEAT

Heat flows from a substance of higher temperature to bodies of lower temperature in the same manner that water flows down a hill, and like water, it can be raised again to a higher level so that it may repeat its cycle.

When two substances of different temperatures are brought in contact with each other, the heat will immediately flow from the warmer substance to the colder substance. The greater the difference in temperature between the two substances, the faster the heat flow. As the temperature of the substances tends to equalize, the flow of heat slows and stops completely when the temperatures are equalized. This

characteristic is used in refrigeration. The heat of the air, of the lining of the refrigerator, and of the food to be preserved is transferred to a colder substance, called the refrigerant.

Three methods by which heat may be transferred from a warmer substance to a colder substance are conduction, convection, and radiation. These principles are explained in chapter 4 of this TRAMAN.

SPECIFIC HEAT

SPECIFIC HEAT is the ratio between the quantity of heat required to change the temperature of 1 pound of any substance 1°F, as compared to the quantity of heat required to change 1 pound of water 1°F. Specific heat is equal to the number of Btu required to raise the temperature of 1 pound of a substance 1°F. For example, the specific heat of milk is .92, which means that 92 Btu will be needed to raise 100 pounds of milk 1°F. The specific heat of water is 1, by adoption as a standard, and specific heat of another substance (solid, liquid, or gas) is determined experimentally by comparing it to water. Specific heat also expresses the heat-holding capacity of a substance compared to that of water.

A key **RULE** to remember is that .5 Btu of heat is required to raise 1 pound of ice 1°F when the temperature is below 32°F; and .5 Btu of heat is required to raise 1 pound of steam 1°F above the temperature of 212°F.

SENSIBLE HEAT

Heat that is added to, or subtracted from, a substance that changes its temperature but not its physical state is called **SENSIBLE HEAT**. It is the heat that can be indicated on a thermometer. This is the heat human senses also can react to, at least within certain ranges. For example, if a person put their finger into a cup of water, the senses readily tell that person whether it is cold, cool, tepid, hot, or very hot. Sensible heat is applied to a solid, a liquid, or a gas/vapor as indicated on a thermometer. The term *sensible heat* does not apply to the process of conversion from one physical state to another.

LATENT HEAT

LATENT HEAT, or hidden heat, is the term used for the heat absorbed or given off by a substance while it is changing its physical state. When this occurs, the heat given off or absorbed does **NOT** cause a

temperature change in the substance. In other words, sensible heat is the term for heat that affects the temperature of things; latent heat is the term for heat that affects the physical state of things.

To understand the concept of latent heat, you must realize that many substances may exist as solids, as liquids, or as gases, depending primarily upon the temperatures and pressure to which they are subjected. To change a solid to a liquid or a liquid to a gas, **ADD HEAT**; to change a gas to a liquid or a liquid to a solid, **REMOVE HEAT**. Suppose you take an uncovered pan of cold water and put it over a burner. The sensible heat of the water increases and so does the temperature. As you continue adding heat to the water in the pan, the temperature of the water continues to rise until it reaches 212°F. What is happening? The water is now absorbing its latent heat and is changing from a liquid to a vapor. The heat required to change a liquid to a gas (or, the heat that must be removed from a gas to condense it to a liquid) without any change in temperature is known as the **LATENT HEAT OF VAPORIZATION**.

Now suppose you take another pan of cold water and put it in a place where the temperature is below 32°F. The water gradually loses heat to its surroundings, and the temperature of the water drops to 32°F until all the water has changed to ice. While the water is changing to ice, however, it is still losing heat to its surroundings. The heat that must be removed from a substance to change it from a liquid to a solid (or, the heat which must be added to a solid to change it to a liquid) without change in temperature is called the **LATENT HEAT OF FUSION**. Note the amount of heat required to cause a change of state (or the amount of heat given off when a substance changes its state) varies according to the pressure under which the process takes place. Figure 6-2 shows the relationship between sensible heat and latent heat for one substance – water at atmospheric pressure. To raise the temperature of 1 pound of ice from 0°F to 32°F, you must add 16 Btu. To change the pound of ice at 32°F to a pound of water at 32°F, you add 144 Btu (latent heat of fusion). There is no change in temperature while the ice is melting. After the ice is melted, however, the temperature of the water is raised when more heat is applied. When 180 Btu are added, the water boils. To change a pound of water at 212°F to a pound of steam at 212°F, you must add 970 Btu (latent heat of vaporization). After the water is converted to steam at 212°F, the application of additional heat causes a rise in the temperature of the steam. When you add 44 Btu

to the steam at 212°F, the steam is superheated to 300°F.

TOTAL HEAT

TOTAL HEAT is the sum of sensible heat and latent heat. Since measurements of the total heat in a certain weight of a substance cannot be started at absolute zero, a temperature is adopted at which it is assumed that there is no heat; and tables of data are constructed on that basis for practical use. Data tables giving the heat content of the most commonly used refrigerants start at 40°F below zero as the assumed point of no heat; tables for water and steam start at 32°F above zero. Tables of data usually contain a notation showing the starting point for heat content measurement.

DAY-TON OF REFRIGERATION

A day-ton of refrigeration (sometimes incorrectly called a ton of refrigeration) is the amount of refrigeration produced by melting 1 ton of ice at a temperature of 32°F in 24 hours. A day-ton is often used to express the amount of cooling produced by a refrigerator or air-conditioner. For example, a 1-ton air-conditioner can remove as much heat in 24 hours as 1 ton of 32°F ice that melts and becomes water at 32°F.

It is a rate of removing heat, rather than a quantity of heat. A rate can be converted to Btu per day, hour, or minute. To find the rate, proceed as follows:

- Per Day: Multiply 2,000 (number of pounds of ice in 1 ton) by 144 (latent heat of fusion per pound) = 288,000 Btu per day
- Per Hour: 288,000 (Btu per day) ÷ 24 (hours in a day) = 12,000

So, a "1-ton" air-conditioner would have a rating of 12,000 Btu per hour.

PRESSURE

PRESSURE is defined as a force per unit area. It is usually measured in pounds per square inch (psi). Pressure may be in one direction, several directions, or in all directions, as shown in figure 6-3. The ice (solid) exerts pressure downward. The water (fluid) exerts pressure on all wetted surfaces of the container. Gases exert pressure on all inside surfaces of their containers.

Pressure is usually measured on gauges that have one of two different scales. One scale is read as so many pounds per square inch gauge (psig) and indicates the pressure above atmospheric pressure surrounding the gauge. The other type of scale is read as so many pounds per square inch absolute (psia) and indicates the pressure above absolute zero pressure (a perfect vacuum).

Atmospheric Pressure

Atmospheric pressure is the pressure of the weight of air above a point on, above, or under the earth. At sea level, ATMOSPHERIC PRESSURE is 14.7 psia, as shown in figure 6-4. As one ascends, the atmospheric pressure decreases about 1.0 psi for every 2,343 feet. Below sea level in excavations and depressions, atmospheric pressure increases. Pressures underwater differ from those under air only because the weight of the water must be added to the pressure of the air.

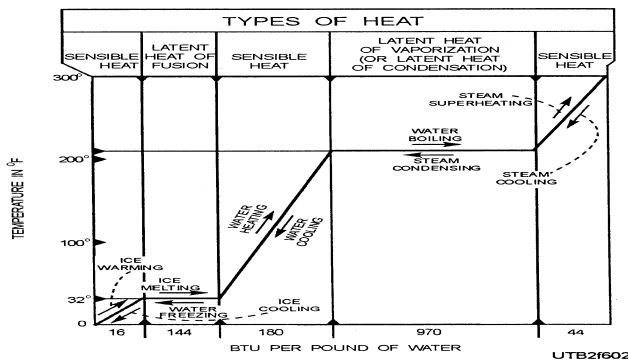

Figure 6-2.—Relationship between temperature and the amount of heat required per pound (for water at atmospheric pressure).

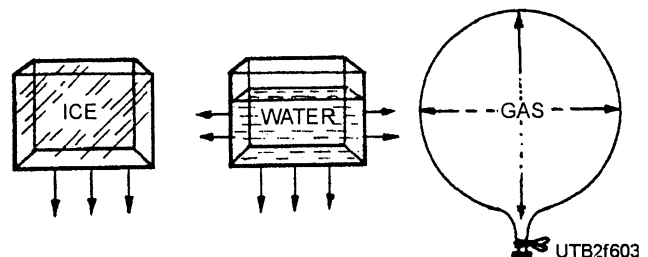

Figure 6-3.—Exertion of pressures.

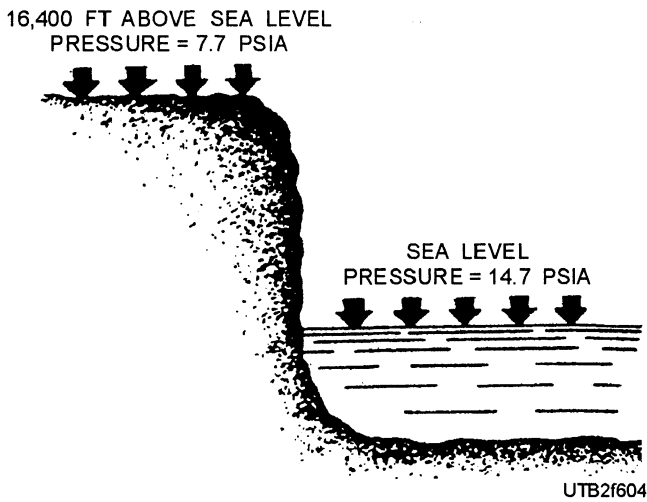

Figure 6-4.—Atmospheric pressure.

Scale Relationships

A relationship exists between the readings of a gauge calibrated in psig and calibrated in psia. As shown in figure 6-5, when the psig gauge reads 0, the

ABSOLUTE SCALE (PSIA)	GAUGE SCALE (PSIG)	INCHES OF MERCURY	INCHES OF WATER
44.7	30	NOT USED	NOT USED
24.7	10	NOT USED	NOT USED
14.7	0	0	0
0	NOT USED	-30	-408

UTB2f605

Figure 6-5.—Pressure relationship.

psia gauge reads the atmospheric pressure (14.7 psia at sea level). In other words, the psia reading equals the psig reading plus the atmospheric pressure (7.7 psia at 16,400 feet), or, a psig reading equals the psia reading minus the atmospheric pressure.

For pressure less than the atmospheric pressure (partial vacuums), a measuring device with a scale reading in inches of mercury (Hg) or in inches of water (H₂O) is used. A perfect vacuum is equal to -30 inches of mercury or -408 inches of water (fig. 6-5). In refrigeration work, pressures above atmospheric are measured in pounds per square inch, and pressures below atmospheric are measured in inches of mercury.

Effects of Pressure on Gases

The exertion of pressure on a substance with a constant temperature decreases its volume in proportion to the increase of pressure. For example, suppose that a given amount of gas is placed in a cylinder that is sealed on one end and has a movable piston on the other end. When 60 psi of absolute pressure is exerted on the piston, as shown in view A of figure 6-6, the volume of the gas is compressed to 3 cubic feet. When 90 psi of absolute pressure is exerted on the piston, as shown in view B, the volume of the gas is compressed to 1.5 cubic feet. Finally, when 180 psi of absolute pressure is exerted on the piston, as shown in view C, the volume of the gas is compressed to 1 cubic foot. Thus, if a given amount of gas is confined in a container and subject to changes of pressure, its volume changes, so the product of volume multiplied by absolute pressure is always the same.

Pressure has a relationship to the boiling point of a substance. There is a definite temperature at which a liquid boils for every definite pressure exerted upon it.

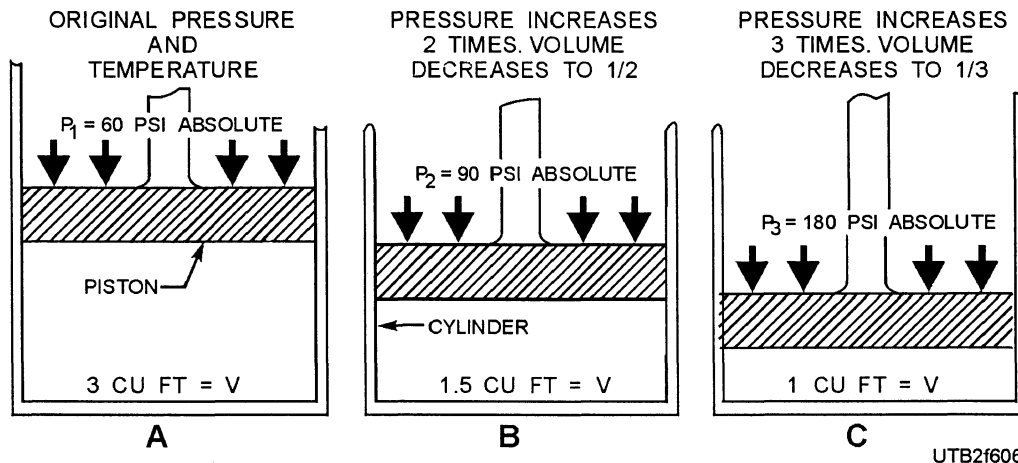

UTB2f606

Figure 6-6.—Pressure-volume relationship.

For instance, water boils at 212°F at atmospheric pressure (14.7 psia), as shown in view A, figure 6-7. The same water boils at 228°F if the pressure is raised 5.3 psig (20 psia), as shown in view B, figure 6-7. On the other hand, the same water boils at 32°F in a partial vacuum of 29.74 inches of mercury (Hg), as shown in figure 6-8.

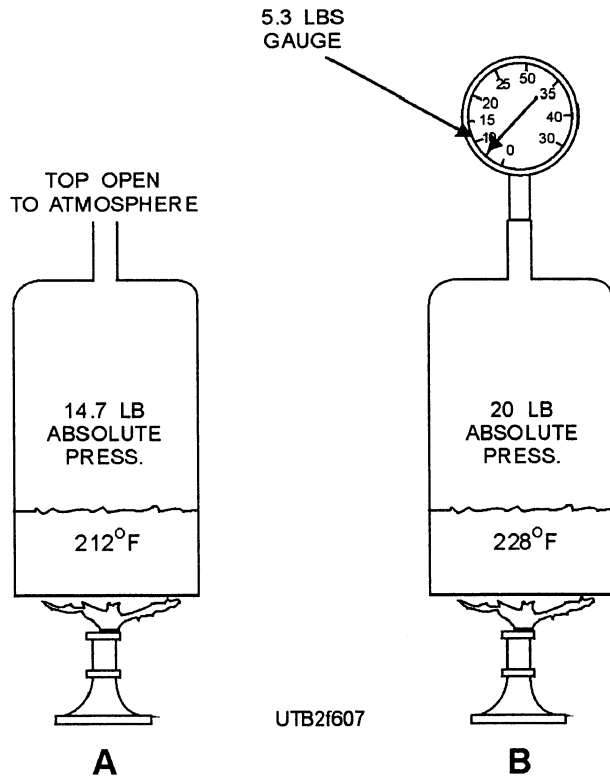

Figure 6-7.—A. Water boils at atmospheric pressure; B. Water boils at 20-psia absolute pressure.

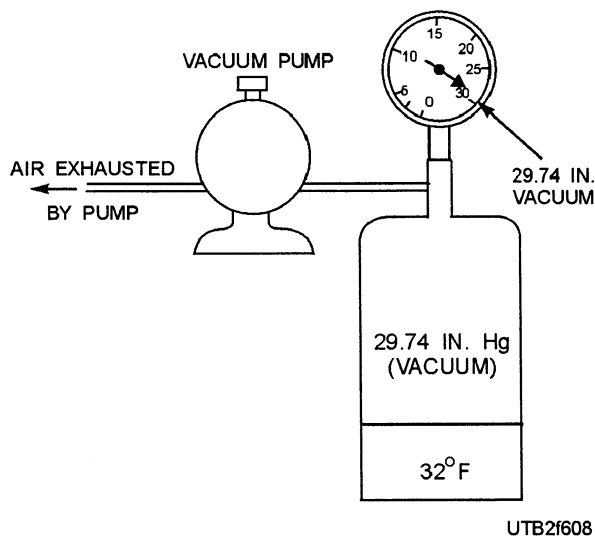

Figure 6-8.—Water boils quicker in a vacuum.

This effect of reduced pressure on the boiling temperature of refrigerants makes the operation of a refrigeration system possible. The pressure temperature relationship chart in figure 6-9 gives the pressures for several different refrigerants.

An increase in the temperature of a refrigerant results in an increase in pressure, and a decrease in temperature causes a decrease in pressure. By the same token, a decrease in pressure results in a corresponding decrease in temperature.

This means that as the pressure of a refrigerant is increased, so is the temperature at which the refrigerant boils. Thus, by regulating the pressure of the refrigerant, the temperature at which evaporation takes place and at which the latent heat of evaporation is used can be controlled.

VAPORIZATION

VAPORIZATION is the process of changing a liquid to vapor, either by evaporation or boiling. When a glass is filled with water, as shown in figure 6-10, and exposed to the rays of the sun for a day or two, you should note that the water level drops gradually. The loss of water is due to evaporation. Evaporation, in this case, takes place only at the surface of the liquid. It is gradual, but the evaporation of the water can be speeded up if additional heat is applied to it. In this case, the boiling of the water takes place throughout the interior of the liquid. Thus the absorption of heat by a liquid causes it to boil and evaporate.

Vaporization can also be increased by reducing the pressure on the liquid, as shown in figure 6-11. Pressure reduction lowers the temperature at which liquid boils and hastens its evaporation. When a liquid evaporates, it absorbs heat from warmer surrounding objects and cools them. Refrigeration by evaporation is based on this method. The liquid is allowed to expand under reduced pressure, vaporizing and extracting heat from the container (freezing compartment), as it changes from a liquid to a gas. After the gas is expanded (and heated), it is compressed, cooled, and condensed into a liquid again.

CONDENSATION

CONDENSATION is the process of changing a vapor into a liquid. For example, in figure 6-12, a warm atmosphere gives up heat to a cold glass of water, causing moisture to condense out of the air and form on the outside surface of the glass. Thus the removal of heat from a vapor causes the vapor to condense.

PRESSURE TEMPERATURE CHART												
Temp °F	113	141b	123	11	114	124	134a	12	500	22	502	125
-40.0	29.5	29.0	28.8	28.4	26.1	22.8*	14.7	11.0	7.6	0.6	4.1	4.9
-35.0	29.4	28.8	28.6	28.1	25.4		12.3	8.4	4.6	2.6	6.5	
-30.0	29.3	28.6	28.3	27.8	24.7	20.2*	9.7	5.5	1.2	4.9	9.2	10.6
-25.0	29.2	28.3	28.1	27.4	23.8		6.8	2.3	1.2	7.5	12.1	
-20.0	29.0	28.1	27.7	27.0	22.9	16.9*	3.6	0.6	3.2	10.2	15.3	17.4
-15.0	28.8	27.7	27.3	26.6	21.8		0.0	2.5	5.4	13.2	18.8	
-10.0	28.7	27.3	26.9	26.0	20.6	12.7*	2.0	4.5	7.8	16.5	22.6	25.6
-5.0	28.4	26.9	26.4	25.4	19.3		4.1	6.7	10.4	20.1	26.7	
0.0	28.2	26.4	25.8	24.7	17.8	7.6*	6.5	9.2	13.3	24.0	31.1	35.1
5.0	27.9	25.8	25.2	23.9	16.2		9.1	11.8	16.4	28.3	35.9	
10.0	27.5	25.2	24.5	23.1	14.4	1.4*	12.0	14.7	19.7	32.8	41.0	46.3
15.0	27.2	24.5	23.7	22.1	12.4		15.1	17.7	23.3	37.8	46.5	
20.0	26.7	23.7	22.8	21.1	10.2	3.0	18.4	21.1	27.2	43.1	52.5	59.2
25.0	26.3	22.8	21.8	19.9	7.8		22.1	24.6	31.4	48.8	58.8	
30.0	25.7	21.8	20.7	18.6	5.1	7.5	26.1	28.5	36.0	54.9	65.6	74.1
35.0	25.1	20.7	19.5	17.1	2.2		30.4	32.6	40.8	61.5	72.8	
40.0	24.4	19.5	18.1	15.6	0.4	12.7	35.0	37.0	46.0	68.5	80.5	91.2
45.0	23.7	18.1	16.6	13.8	2.1		40.0	41.7	51.6	76.1	88.7	
50.0	22.9	16.7	15.0	12.0	3.9	18.8	45.4	46.7	57.5	84.1	97.4	110.6
55.0	21.9	13.1	13.1	9.9	5.9		51.2	52.1	63.8	92.6	106.6	
60.0	20.9	13.4	11.2	7.7	8.0	25.9	57.4	57.8	70.6	101.6	116.4	132.8
65.0	19.8	11.5	9.0	5.2	10.3		64.0	63.8	77.7	111.3	127.6	
70.0	18.6	9.4	6.6	2.6	12.7	34.1	71.1	70.2	85.3	121.4	137.6	157.8
75.0	17.3	7.2	4.1	0.1	15.3		78.6	77.0	93.4	132.2	149.1	
80.0	15.8	4.8	1.3	1.6	18.2	43.5	86.7	84.2	101.9	143.7	161.2	186.0
85.0	14.2	2.3	0.9	3.3	21.2		95.2	91.7	110.9	155.7	174.0	
90.0	12.5	0.2	2.5	5.0	24.4	54.1	104.3	99.7	120.5	168.4	187.4	217.5
95.0	10.6	1.7	4.2	6.9	27.8		113.9	108.2	130.5	181.8	201.4	
100.0	8.6	3.2	6.1	8.9	31.4	66.2	124.1	117.0	141.1	196.0	216.2	252.7
105.0	6.4	4.8	8.1	11.1	35.3		134.9	126.4	152.2	210.8	231.7	
110.0	4.0	6.6	10.2	13.4	39.4	79.7	146.3	136.2	163.9	226.4	247.9	291.6
115.0	1.4	8.4	12.6	15.9	43.8		158.4	146.5	176.3	242.8	264.9	
120.0	0.7	10.4	15.0	18.5	48.4	94.9	171.1	157.3	189.2	260.0	282.7	334.3

Vapor pressures in psig, except (*) which are inches of mercury (Hg).

UTBf609

Figure 6-9.—Pressure temperature chart.

An increase in pressure on a confined vapor also causes the vapor to change to a liquid. This fact is shown in figure 6-13. When the compressor increases the pressure on the vapor, the condensing vapor changes to a liquid and gives up heat to the cooler surrounding objects and atmosphere.

These conditions exist when the vaporized refrigerant is compressed by the compressor of a refrigeration system and forced into the condenser.

The condenser removes the superheat, latent heat of vaporization, and, in some cases, sensible heat from the refrigerant.

- Q1. When two substances of different temperatures are brought in contact with each other, heat will flow from the colder substance to the warmer substance. True/False.
- Q2. What is specific heat?

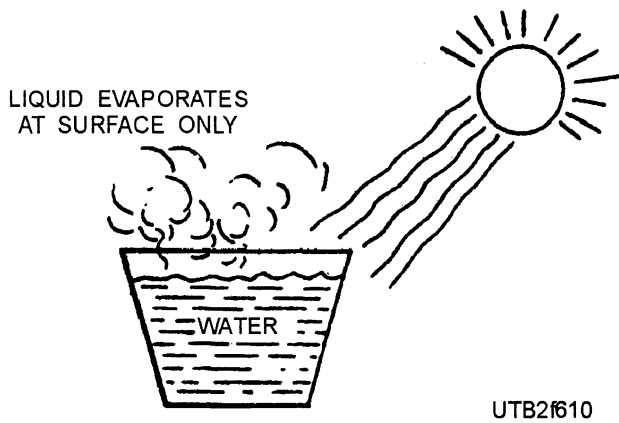

UTB2f610

Figure 6-10.—Normal surface evaporation.

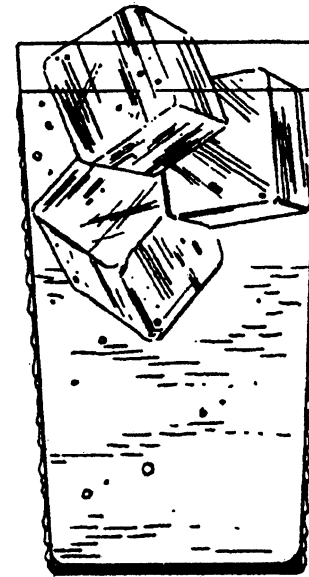

UTB2f612

Figure 6-12.—Condensation of moisture on a glass of cold water.

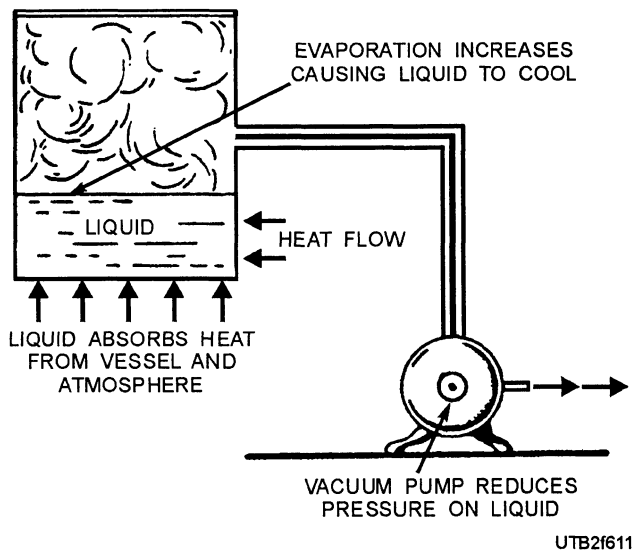

UTB2f611

Figure 6-11.—Evaporation by pressure reduction.

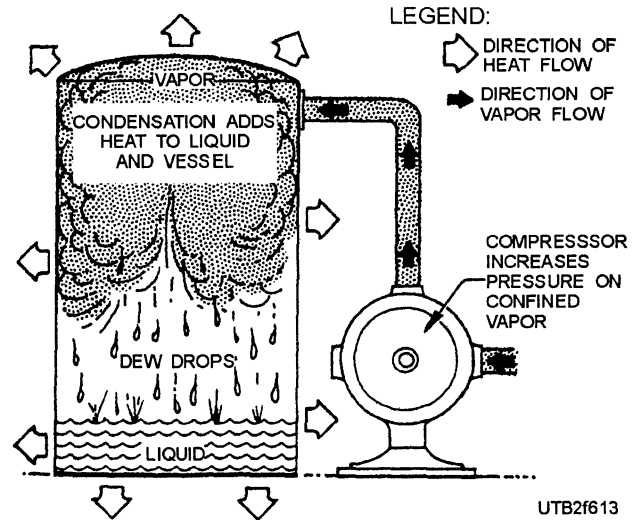

UTB2f613

Figure 6-13.—Pressure causes a vapor to condense.

- Q3. What is the difference between "sensible heat" and "latent heat"?
- Q4. What is the atmospheric pressure at 4,686 feet?
- Q5. Exertion of pressure on a substance with a constant pressure does what to the substance?
- Q4. Removal of heat from a vapor causes what change to occur?

MECHANICAL REFRIGERATION SYSTEMS

Learning Objective: Identify and understand different types of refrigeration system components and their operation.

Mechanical refrigeration systems are an arrangement of components in a system that puts the theory of gases into practice to provide artificial cooling. To do this, you must provide the following: (1) a metered supply of relatively cool liquid under pressure; (2) a device in the space to be cooled that operates at reduced pressure so that when the cool, pressurized liquid enters, it will expand, evaporate, and take heat from the space to be cooled; (3) a means of repressurizing (compressing) the vapor; and (4) a means of condensing it back into a liquid, removing its

superheat, latent heat of vaporization, and some of its sensible heat.

Every mechanical refrigeration system operates at two different pressure levels. The dividing line is shown in figure 6-14. The line passes through the discharge valves of the compressor on one end and through the orifice of the metering device or expansion valve on the other.

The high-pressure side of the refrigeration system comprises all the components that operate at or above condensing pressure. These components are the discharge side of the compressor, the condenser, the receiver, and all interconnected tubing up to the metering device or expansion valve.

The low-pressure side of a refrigeration system consists of all the components that operate at or below evaporating pressure. These components comprise the low-pressure side of the expansion valve, the evaporator, and all the interconnecting tubing up to and including the low side of the compressor.

Refrigeration mechanics call the pressure on the high side discharge pressure, head pressure, or high-side pressure. On the low side, the pressure is called suction pressure or low-side pressure.

The refrigeration cycle of a mechanical refrigeration system may be explained by using figure 6-14. The pumping action of the compressor (1) draws vapor drawn from the evaporator (2). This action reduces the pressure in the evaporator, causing the liquid particles to evaporate. As the liquid particles evaporate, the evaporator is cooled. Both the liquid and vapor refrigerant tend to extract heat from the warmer objects in the insulated refrigerator cabinet. The ability of the liquid to absorb heat as it vaporizes is very high in comparison to that of the vapor. As the liquid refrigerant is vaporized, the low-pressure vapor is drawn into the suction line by the suction action of the compressor (1). The evaporation of the liquid refrigerant would soon remove the entire refrigerant from the evaporator if it were not replaced. The replacement of the liquid refrigerant is usually controlled by a metering device or expansion valve (3). This device acts as a restrictor to the flow of the liquid refrigerant in the liquid line. Its function is to change the high-pressure, subcooled liquid refrigerant to low-pressure, low-temperature liquid particles, which will continue the cycle by absorbing heat.

The refrigerant low-pressure vapor drawn from the evaporator by the compressor through the suction line, in turn, is compressed by the compressor to a high-pressure vapor, which is forced into the

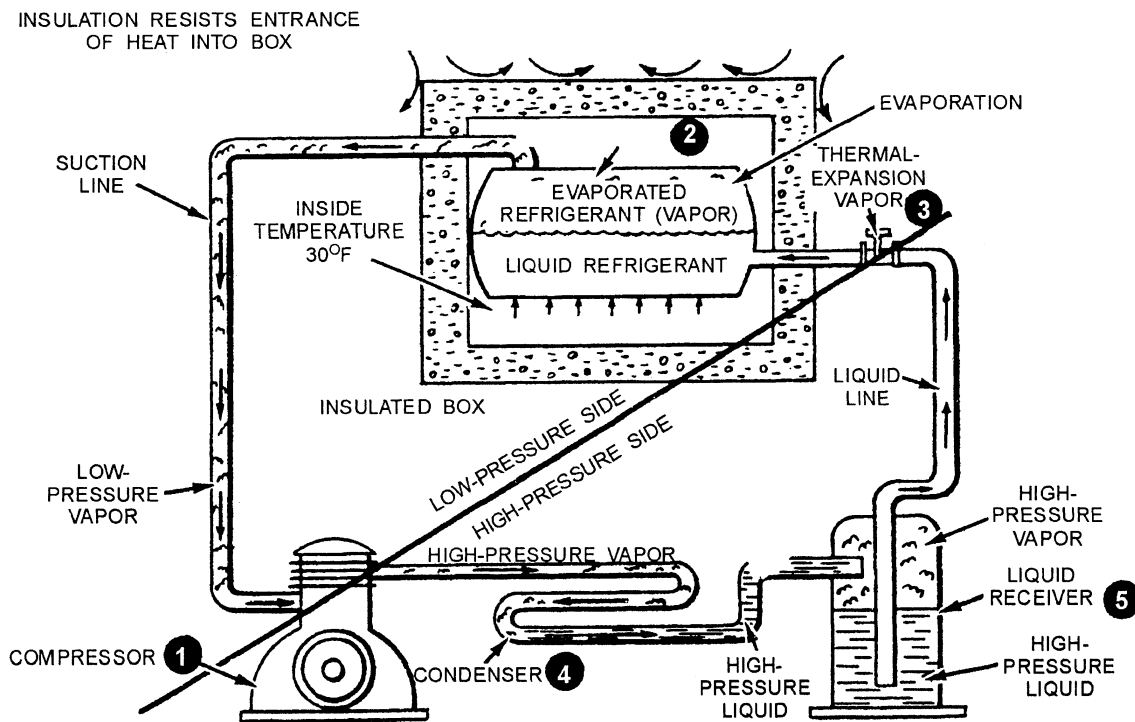

UTB2f614

Figure 6-14.—Refrigeration cycle.

condenser (4). In the condenser, the high-pressure vapor condenses to a liquid under high pressure and gives up heat to the condenser. The heat is removed from the condenser by the cooling medium of air or water. The condensed liquid refrigerant is then forced into the liquid receiver (5) and through the liquid line to the expansion valve by pressure created by the compressor, making a complete cycle.

Although the receiver is indicated as part of the refrigeration system in figure 6-14, it is not a vital component. However, the omission of the receiver requires exactly the proper amount of refrigerant in the system. The refrigerant charge in systems without receivers is to be considered critical, as any variations in quantity affects the operating efficiency of the unit.

The refrigeration cycle of any refrigeration system must be clearly understood by a mechanic before repairing the system. Knowing how a refrigerant works makes it easier to detect faults in a refrigeration system.

COMPONENTS

The refrigeration system consists of four basic components—the compressor, the condenser, the liquid receiver, the evaporator, and the control devices. These components are essential for any system to operate on the principles previously discussed. Information on these components is described in the following sections.

Compressors

Refrigeration compressors have but one purpose—to withdraw the heat-laden refrigerant vapor from the evaporator and compress the gas to a pressure that will liquefy in the condenser. The designs of compressors vary, depending upon the application and type of refrigerant. There are three types of compressors classified according to the principle of operation—reciprocating, rotary, and centrifugal.

You may recall that material on compressors was presented in chapter 6, *Utilitiesman Basic*, volume 1. They will not be explained further here except to discuss the special methods used to seal compressors to prevent escape of refrigerant. Many refrigerator compressors have components besides those normally found on compressors, such as unloaders, oil pumps, mufflers, and so on. These devices are too complicated to explain here. Before repairing any compressor, check the manufacturer's manual for an explanation of their operation, adjustment, and repair.

EXTERNAL DRIVE COMPRESSOR.—An external drive or open-type compressor is bolted together. Its crankshaft extends through the crankcase and is driven by a flywheel (pulley) and belt, or it can be driven directly by an electric motor. A leakproof seal must be maintained where the crankshaft extends out of the crankcase of an open-type compressor. The seal must be designed to hold the pressure developed inside of the compressor. It must prevent refrigerant and oil from leaking out and prevent air and moisture from entering the compressor. Two types of seals are used—the stationary bellows seal and the rotating bellows seal.

An internal stationary crankshaft seal shown in figure 6-15 consists of a corrugated thin brass tube (seal bellows) fastened to a bronze ring (seal guide) at one end and to the flange plate at the other. The flange plate is bolted to the crankcase with a gasket between the two units. A spring presses the seal guide mounted on the other end of the bellows against a seal ring positioned against the shoulder of the crankshaft. As the pressure builds up in the crankcase, the bellows tend to lengthen, causing additional force to press the seal guide against the seal ring. Oil from the crankcase lubricates the surfaces of the seal guide and seal ring. This forms a gastight sea whether the compressor is operating or idle.

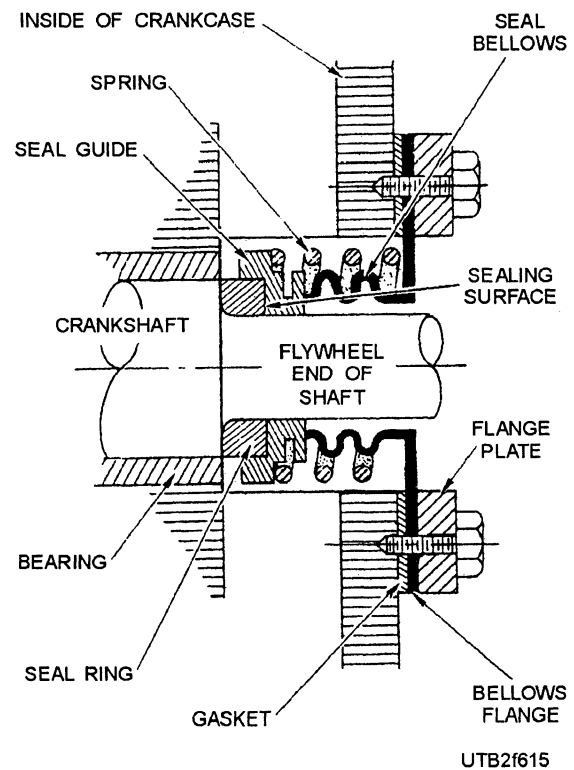

Figure 6-15.—An internal stationary bellows crankshaft seal.

An external stationary bellows crankshaft seal is shown in figure 6-16. This seal is the same as the internal seal, except it is positioned on the outside of the crankcase.

An external rotating bellows crankcase seal is shown in figure 6-17. This seal turns with the crankshaft. This seal also consists of a corrugated thin brass tube (seal bellows) with a seal ring fastened to one end and a seal flange fastened to the other. A seal spring is enclosed within the bellows. The complete bellows assembly slips on the end of the crankshaft and is held in place by a nut. The seal ring that is the inner portion of the bellows is positioned against a nonrotating seal fastened directly to the crankcase. During operation, the complete bellows assembly rotates with the shaft, causing the seal ring to rotate against the stationary seal. The pressure of the seal spring holds the seal ring against the seal. The expansion of the bellows caused by the pressure from the crankcase also exerts pressure on the seal ring. Because of this design, double pressure is exerted against the seal ring to provide a gastight seal.

HERMETIC COMPRESSOR.—In the hermetically sealed compressor, the electric motor and compressor are both in the same airtight (hermetic) housing and share the same shaft. Figure 6-18 shows a hermetically sealed unit. Note that after assembly, the two halves of the case are welded together to form an airtight cover. Figure 6-19 shows an accessible type of hermetically sealed unit. The compressor, in this case, is a double-piston reciprocating type. Other compressors may be of the centrifugal or rotary types.

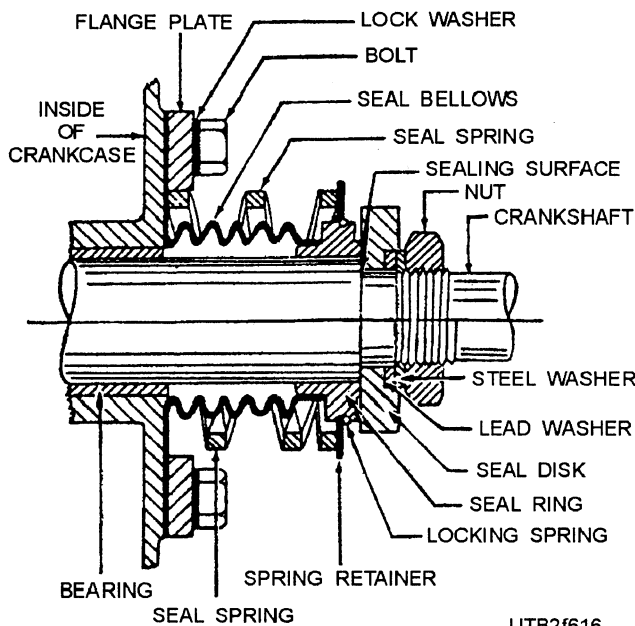
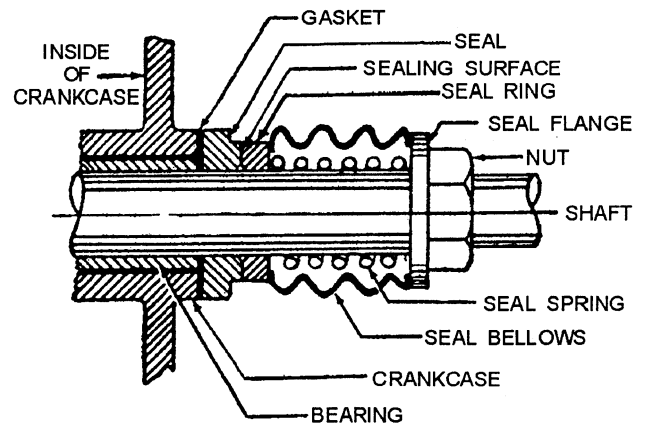

Figure 6-16.—An external stationary bellows crankshaft seal.



UTB2f617

Figure 6-17.—An external rotating bellows crankcase seal.

Cooling and lubrication are provided by the circulating oil and the movement of the refrigerant vapor throughout the case.

The advantages of the hermetically sealed unit (elimination of pulleys, belts and other coupling methods, elimination of a source of refrigerant leaks) are offset somewhat by the inaccessibility for repair and generally lower capacity.

Condensers

The condenser removes and dissipates heat from the compressed vapor to the surrounding air or water to

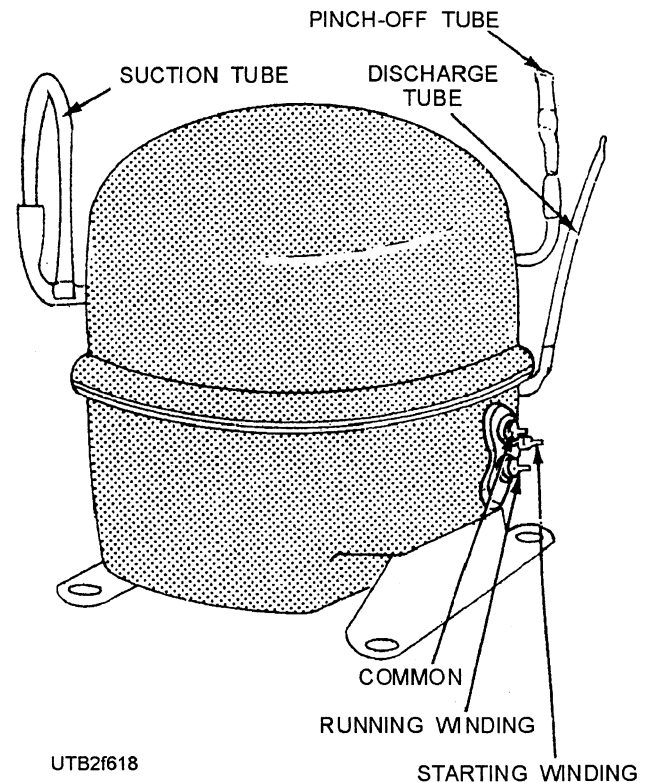

UTB2f618

Figure 6-18.—Hermetic compressor.

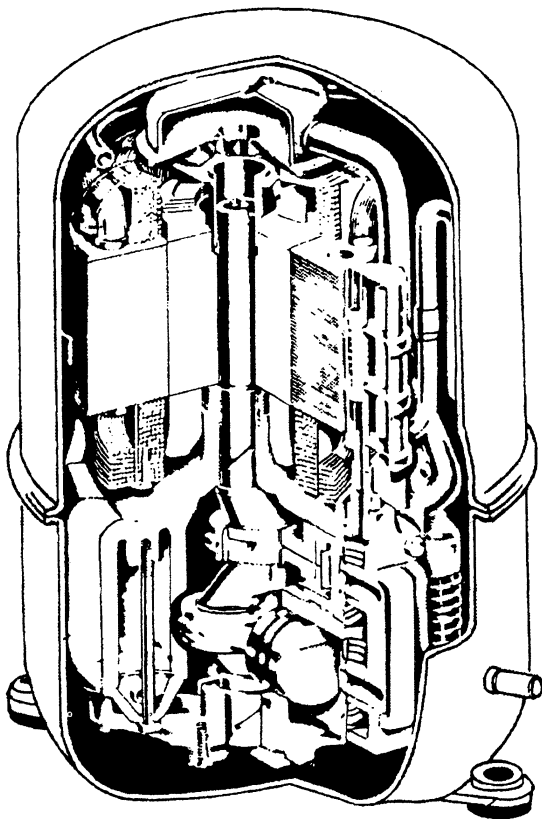

UTB2f619

Figure 6-19.—A cutaway view of a hermetic compressor and motor.

condense the refrigerant vapor to a liquid. The liquid refrigerant then falls by gravity to a receiver (usually located below the condenser), where it is stored, and available for future use in the system.

There are three basic types of condensers—air-cooled, water-cooled, and evaporative. The first two are the most common, but the evaporative types are used where low-quality water and its disposal make the use of circulating water-cooled types impractical.

AIR-COOLED CONDENSERS.—The construction of air-cooled condensers makes use of several layers of small tubing formed into flat cells. The external surface of this tubing is provided with fins to ease the transfer of heat from the condensing refrigerant inside the tubes to the air circulated through the condenser core around the external surface of the tubes (fig. 6-20). Condensation takes place as the refrigerant flows through the tubing, and the liquid refrigerant is discharged from the lower ends of the tubing coils to a liquid receiver on the condensing unit assembly.

WATER-COOLED CONDENSERS.—Water-cooled condensers are of the multipass shell and tube type, with circulating water flowing through the tubes. The refrigerant vapor is admitted to the shell

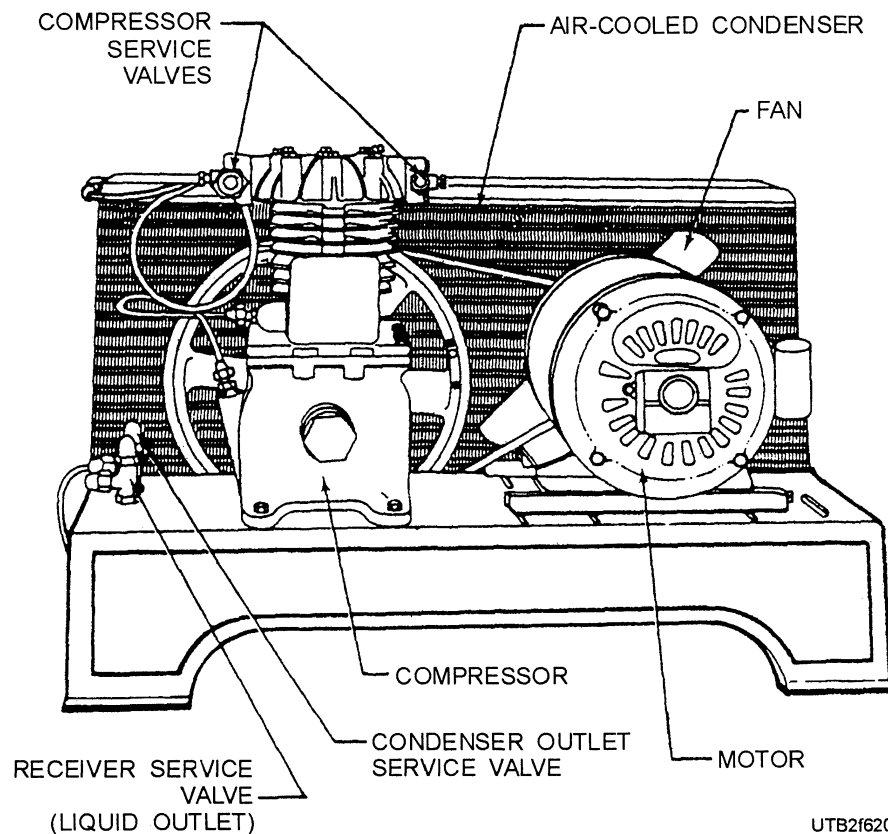

UTB2f620

Figure 6-20.—Air-cooled condenser mounted on a compressor unit.

and condensed on the outer surfaces of the tubes (fig. 6-21).

The condenser is constructed with a tube sheet brazed to each end of a shell. Copper-nickel tubes are inserted through drilled openings in the tube sheet and are expanded or rolled into the tube sheet to make a gastight seal. Headers, or water boxes, are bolted to the tube sheet to complete the waterside of the condenser. Zinc-wasting bars are installed in the water boxes to minimize electrolytic corrosion of the condenser parts.

A purge connection with a valve is at the top side of the condenser shell to allow manual release of any accumulated air in the refrigerant circuit.

The capacity of the water-cooled condenser is affected by the temperature of the water, quantity of water circulated, and the temperature of the refrigerant gas. The capacity of the condenser varies whenever the temperature difference between the refrigerant gas and the water is changed. An increased temperature difference or greater flow of water increases the capacity of the condenser. The use of colder water can cause the temperature difference to increase.

EVAPORATIVE CONDENSERS.—An evaporative condenser operates on the principle that heat can be removed from condensing coils by spraying them with water or letting water drip onto them and then forcing air through the coils by a fan.

This evaporation of the water cools the 'coils and condenses the refrigerant within.

Liquid Receiver

A liquid receiver as shown at position (5) on figure 6-14, serves to accumulate the reserve liquid refrigerant, to provide a storage for off-peak operation, and to permit pumping down of the system. The receiver also serves as a seal against the entrance of gaseous refrigerant into the liquid line. When stop valves are provided at each side of the receiver for confinement of the liquid refrigerant, a pressure relief valve is generally installed between the valves in the receiver and condenser equalizing line to protect the receiver against any excessive hydraulic pressure being built up.

Evaporators

The evaporator is a bank or coil of tubing placed inside the refrigeration space. The refrigerant is at a low-pressure and low-temperature liquid, as it enters the evaporator.

As the refrigerant circulates through the evaporator tubes, it absorbs its heat of vaporization from the surrounding space and substances. The absorption of this heat causes the refrigerant to boil. As the temperature of the surrounding space (and

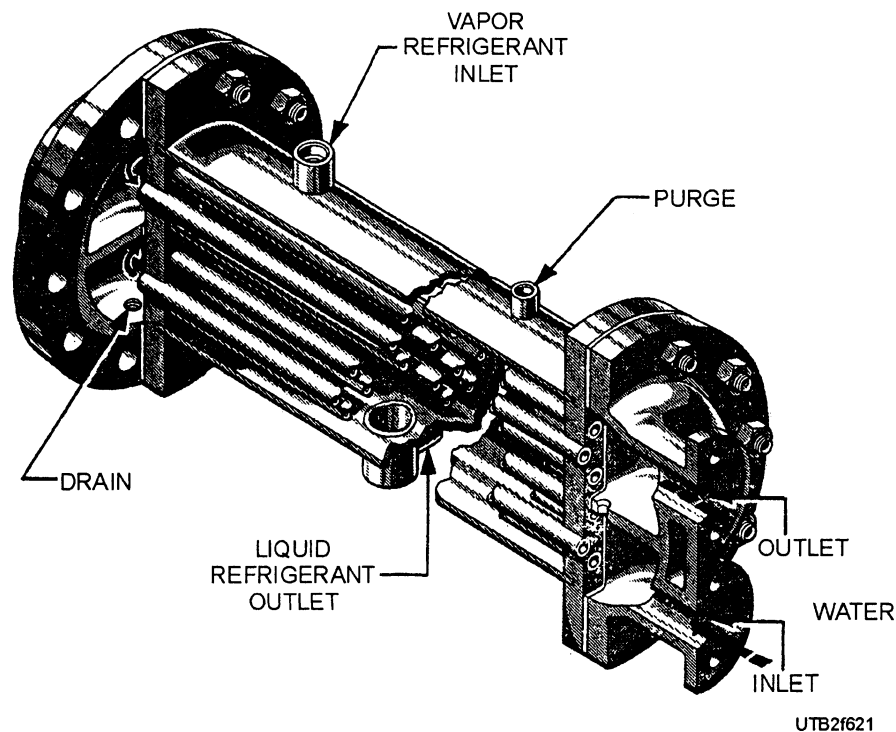

Figure 6-21.—Water-cooled condenser.

contents) is lowered, the liquid refrigerant gradually changes to a vapor. The refrigerant vapor then passes into the suction line by the action of the compressor.

Most evaporators are made of steel, copper, brass, stainless steel, aluminum, or almost any other kind of rolled metal that resists the corrosion of refrigerants and the chemical action of the foods.

Evaporators are mainly of two types—dry or flooded. The inside of a dry evaporator refrigerant is fed to the coils only as fast as necessary to maintain the temperature wanted. The coil is always filled with a mixture of liquid and vapor refrigerant. At the inlet side of the coil, there is mostly liquid; the refrigerant flows through the coil (as required); it is vaporized until, at the end, there is nothing but vapor. In a flooded evaporator, the evaporator is always filled with liquid refrigerant. A float maintains liquid refrigerant at a constant level. As fast as the liquid refrigerant evaporates, the float admits more liquid, and, as a result, the entire inside of the evaporator is flooded with liquid refrigerant up to a certain level determined by the float.

The two basic types of evaporators are further classified by their method of evaporation, either direct expanding or indirect expanding. In the direct-expanding evaporator, heat is transferred directly from the refrigerating space through the tubes and absorbed by the refrigerant. In the indirect-expanding evaporator, the refrigerant in the evaporator is used to cool some secondary medium, other than air. This secondary medium or refrigerant maintains the desired temperature of the space. Usually brine, a solution of calcium chloride is used as the secondary refrigerant.

Natural convection or forced-air circulation is used to circulate air within a refrigerated space. Air around the evaporator must be moved to the stored food so that heat can be extracted, and the warmer air from the food returned to the evaporator. Natural convection can be used by installing the evaporator in the uppermost portion of the space to be refrigerated, so heavier cooled air will fall to the lower food storage and the lighter food-warmed air will rise to the evaporator. Forced-air circulation speeds up this process and is usually used in large refrigerated spaces to ensure all areas are cooled.

Control Devices

To maintain correct operating conditions, control devices are needed in a refrigeration system. Some of the control devices are discussed in this chapter.

METERING DEVICES.—Metering devices, such as expansion valves and float valves, control the flow of liquid refrigerant between the high side and the low side of the system. It is at the end of the line between the condenser and the evaporator. These devices are of five different types: an automatic expansion valve (also known as a constant-pressure expansion valve), a thermostatic expansion valve, low-side and high-side float valves, and a capillary tube.

Automatic Expansion Valve.—An automatic expansion valve (fig. 6-22) maintains a constant pressure in the evaporator. Normally this valve is used only with direct expansion, dry type of evaporators. In operation, the valve feeds enough liquid refrigerant to the evaporator to maintain a constant pressure in the coils. This type of valve is generally used in a system where constant loads are expected. When a large variable load occurs, the valve will not feed enough refrigerant to the evaporator under high load and will overfeed the evaporator at low load. Compressor damage can result when slugs of liquid enter the compressor.

Thermostatic Expansion Valve.—Before discussing the thermostatic expansion valve, let's explain the term SUPERHEAT. A vapor gas is superheated when its temperature is higher than the boiling point corresponding to its pressure. When the boiling point begins, both the liquid and the vapor are at the same temperature. But in an evaporator, as the gas vapor moves along the coils toward the suction line, the gas may absorb additional heat and its temperature rises. The difference in degrees between the saturation temperature and the increased temperature of the gas is called superheat.

A thermostatic expansion valve (fig. 6-22) keeps a constant superheat in the refrigerant vapor leaving the coil. The valve controls the liquid refrigerant, so the evaporator coils maintain the correct amount of refrigerant at all times. The valve has a power element that is activated by a remote bulb located at the end of the evaporator coils. The bulb senses the superheat at the suction line and adjusts the flow of refrigerant into the evaporator. As the superheat increases (suction line), the temperature, and therefore the pressure, in the remote bulb also increases. This increased pressure, applied to the top of the diaphragm, forces it down along with the pin, which, in turn, opens the valve, admitting replacement refrigerant from the receiver to flow into the evaporator. This replacement has three effects. First, it provides additional liquid

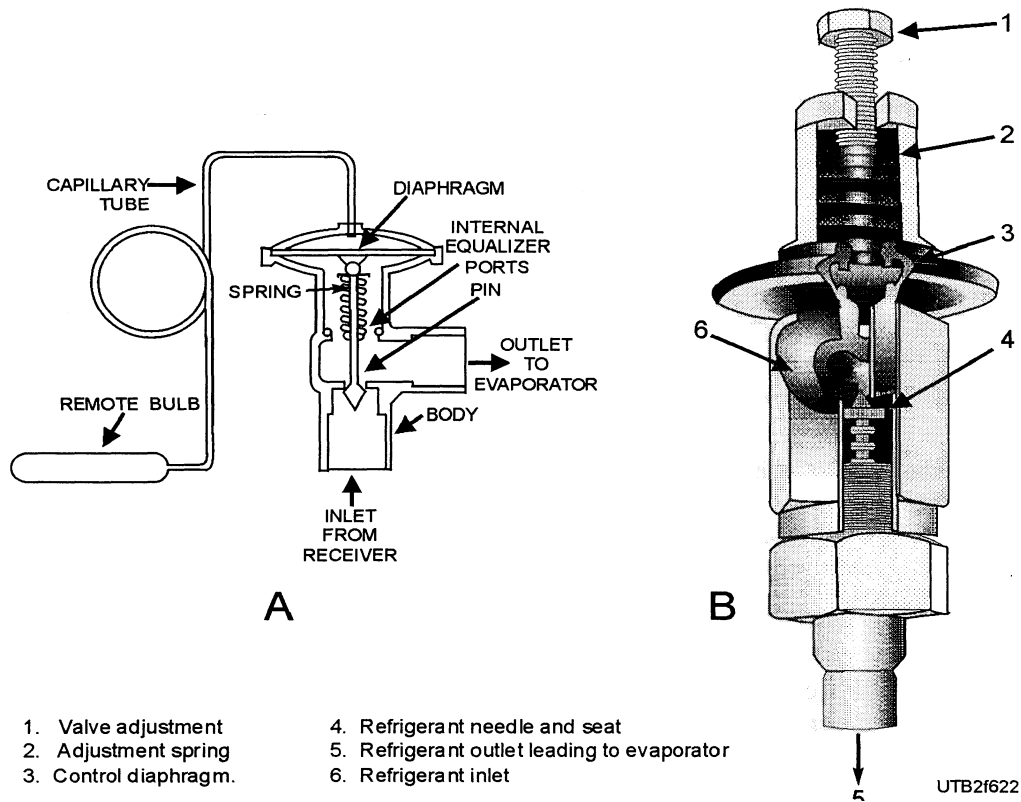

Figure 6-22—A. Thermostatic expansion valve; B. Automatic expansion valve.

refrigerant to absorb heat from the evaporator. Second, it applies higher pressure to the bottom of the diaphragm, forcing it upward, tending to close the valve. And third, it reduces the degree of superheat by forcing more refrigerant through the suction line.

Low-Side Float Expansion Valve.—The low-side float expansion valve (fig. 6-23) controls the liquid refrigerant flow where a flooded evaporator is used. It consists of a ball float in either a chamber or the evaporator on the low-pressure side of the system.

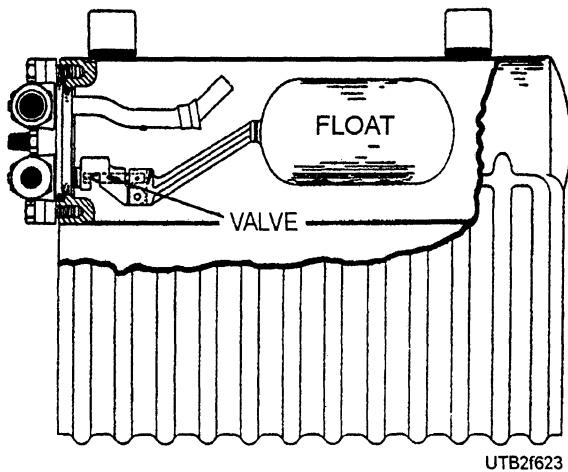

Figure 6-23.—A low-side float expansion valve.

The float actuates a needle valve through a lever mechanism. As the float lowers, refrigerant enters through the open valve; when it rises, the valve closes.

High-Side Float Expansion Valve.—In a high-side float expansion valve (fig. 6-24), the valve float is in a liquid receiver or in an auxiliary container on the high-pressure side of the system. Refrigerant from the condenser flows into the valve and immediately opens it, allowing refrigerant to expand and pass into the evaporator. Refrigerant charge is critical. An overcharge of the system floods back and damages the compressor. An undercharge results in a capacity drop.

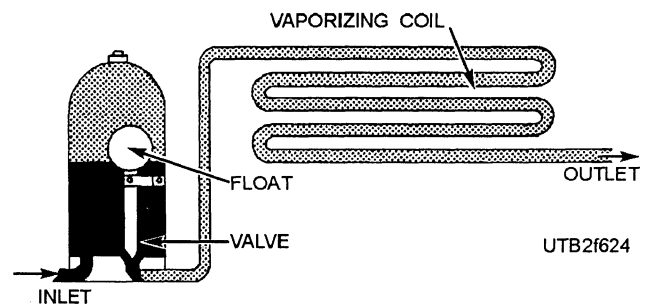

Figure 6-24.—A high-side float expansion valve.

Capillary Tube.—The capillary tube consists of a long tube of small diameter. It acts as a constant throttle on the refrigerant. The length and diameter of the tube are important; any restrictions cause trouble in the system. It feeds refrigerant to the evaporator as fast as it is produced by the condenser. When the quantity of refrigerant in the system is correct or the charge is balanced, the flow of refrigerant from the condenser to the evaporator stops when the compressor unit stops. When the condensing unit is running, the operating characteristics of the capillary tube equipped evaporator are the same as if it were equipped with a high-side float.

The capillary tube is best suited for household boxes, such as freezers and window air-conditioners, where the refrigeration load is reasonably constant and small horsepower motors are used.

Accessory Devices

The four basic or major components of a refrigeration system just described are enough for a refrigeration unit to function. However, additional devices, such as the receiver already described, make for a smoother and more controlled cycle. Some of the accessory devices used on a refrigeration unit are described in this section. Before proceeding, take a close look at figure 6-25 that shows one type of refrigeration system with additional devices installed.

Some of the devices and their functions are explained to help you understand installation and troubleshooting of a refrigeration unit.

RELIEF VALVE.—A refrigeration system is a sealed system in which pressures vary. Excessive pressures can cause a component of the system to explode. The National Refrigeration Code makes the installation of a relief valve mandatory. A spring-loaded relief valve is most often used and it is installed in the compressor discharge line between the compressor discharge connection and the discharge line stop valve to protect the high-pressure side of the system. No valves can be installed between the compressor and the relief valve. The discharge from the relief valve is led to the compressor suction line.

DISCHARGE PRESSURE GAUGE AND THERMOMETER.—A discharge pressure gauge and thermometer are installed in the compressor discharge line (liquid line) to show the pressure and temperature of the compressed refrigerant gas. The temperature indicated on the gauge is always higher than that corresponding to the pressure when the compressor is operating.

COMPRESSOR MOTOR CONTROLS.—The starting and stopping of the compressor motor is usually controlled by either a pressure-actuated or temperature-actuated motor control. The operation of the pressure motor control depends on the relationship

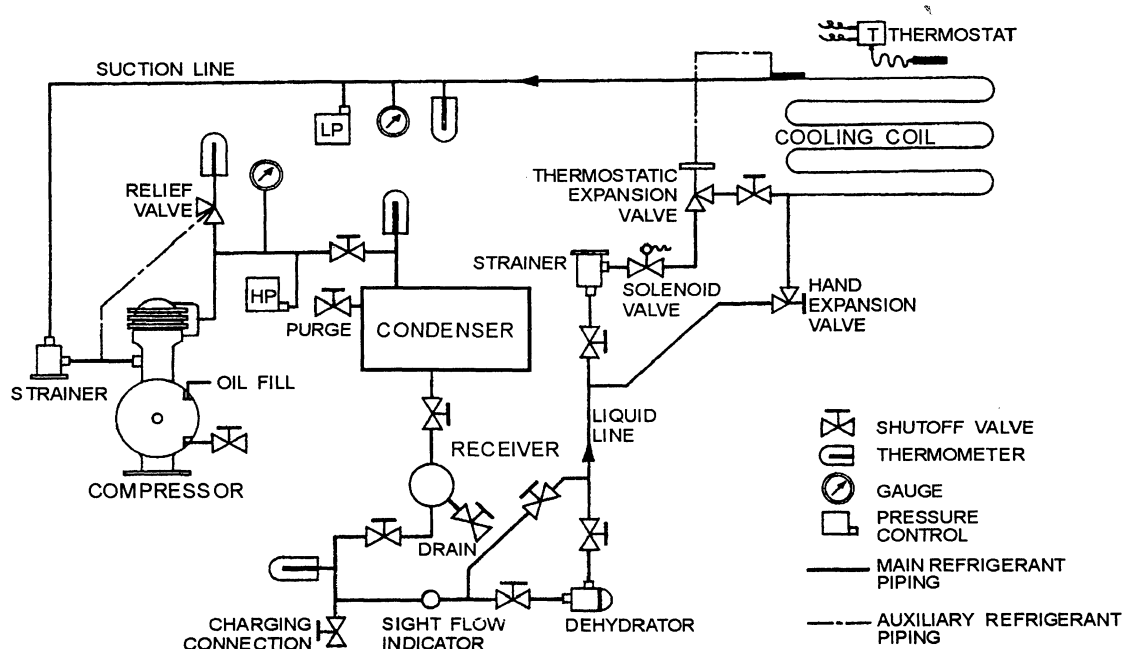

UTB21625

Figure 6-25.—A basic refrigeration system.

between pressure and temperature. A pressure motor control is shown in figure 6-26. The device consists of a low-pressure bellows, or, in some cases, a low-pressure diaphragm, connected by a small diameter tube to the compressor crankcase or to the suction line. The pressure in the suction line or compressor crankcase is transmitted through the tube and actuates the bellows or diaphragm. The bellows move according to the pressure, and its movement causes an electric switch to start (cut in) or stop (cut out) the compressor motor. Adjustments can be made to the start and stop pressures under the manufacturer's instruction. Usually the cutout pressure is adjusted to correspond to a temperature a few degrees below the desired evaporator coil temperature, and the cut-in pressure is adjusted to correspond to the temperature of the coil.

The temperature-actuated motor control is similar to the pressure device. The main difference is that a temperature-sensing bulb and a capillary tube replace the pressure tube. The temperature motor control cuts in or cuts out the compressor according to the temperature in the cooled space.

The refrigeration system may also be equipped with a high-pressure safety cutout switch that shuts off the power to the compressor motor when the high-side pressure exceeds a preset limit.

SOLENOID STOP VALVES.—Solenoid stop valves, or magnetic stop valves, control gas or liquid

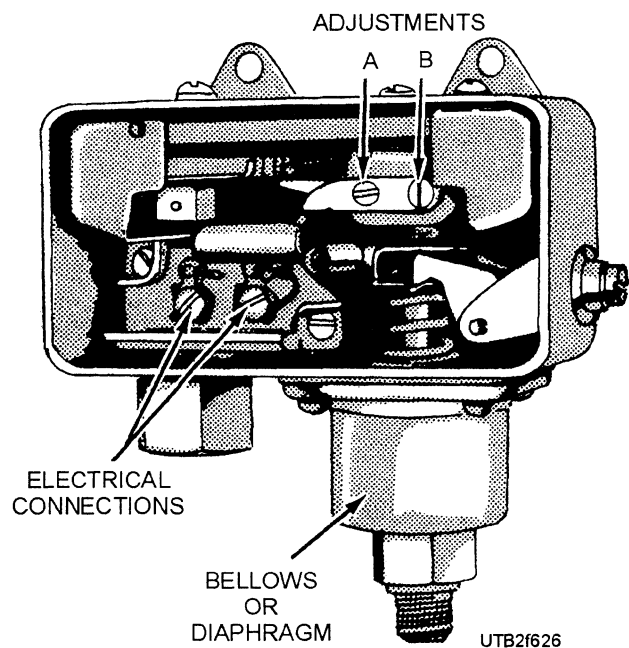

Figure 6-26.—Pressure-actuated motor control.

flow. They are most commonly used to control liquid refrigerant to the expansion valve but are used throughout the system. The compressor motor and solenoid stop valve are electrically in parallel; that is, the electrical power is applied or removed from both at the same time. The liquid line is open for passage of refrigerant only when the compressor is in operation and the solenoid is energized. A typical solenoid stop valve is shown in figure 6-27.

Improper operation of these valves can be caused by a burned-out solenoid coil or foreign material lodged between the stem and the seat of the valve, allowing fluid to leak. Carefully check the valve before replacing or discarding. The valve must be installed so that the coil and plunger are in a true vertical position. When the valve is cocked, the plunger will not reseat properly, causing refrigerant leakage.

THERMOSTAT SWITCH.—Occasionally, a thermostat in the refrigerated space operates a solenoid stop valve, and the compressor motor is controlled independently by a low-pressure switch. The solenoid control switch, or thermostat, makes and breaks the electrical circuit, thereby controlling the liquid refrigerant to the expansion valve. The control bulb is charged with a refrigerant so that temperature changes of the bulb itself produce like changes in pressure within the control bulb. These pressure changes are transmitted through the tubing to the switch power element to operate the switch. The switch opens the contacts and thus releases the solenoid valve, stopping the flow of refrigerant to the cooling coil when the temperature of the refrigerated space has reached the desired point. The compressor continues to operate until it has evacuated the evaporator. The resulting low

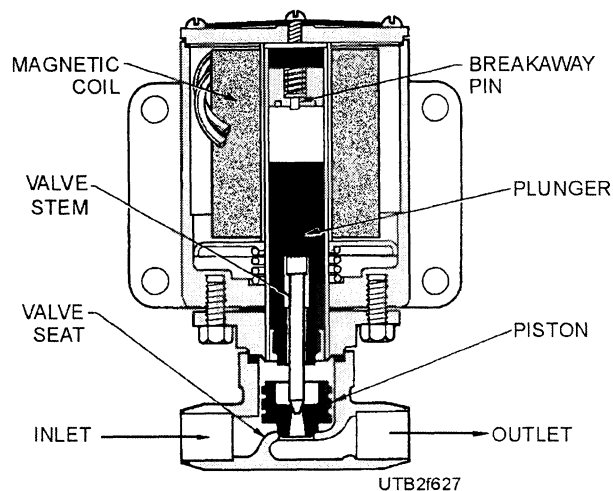

Figure 6-27.—A solenoid stop valve.

pressure in the evaporator then activates the low-pressure switch, which stops the compressor. As the temperature rises, the increase in bulb pressure closes the switch contacts, and the refrigerant is supplied to the expansion valve.

LIQUID LINE.—The refrigerant accumulated in the bottom of the receiver shell is conveyed to the cooling coils through the main refrigerant liquid line. A stop valve and thermometer are usually installed in this line next to the receiver. Where the sight-flow indicator, dehydrator, or filter-drier is close to the receiver, the built-in shutoff valves may be used instead of a separate shutoff valve.

LIQUID LINE FILTER-DRIER OR DEHYDRATOR.—A liquid line filter-drier (fig. 6-28) prevents or removes moisture, dirt, and other foreign materials from the liquid line that would harm the system components and reduce efficiency. This tank like accessory offers some resistance to flow, and, for this reason, some manufacturers install it in a bypass line. A filter-drier consists of a tubular shell with strainers on the inlet and outlet connections to prevent escape of drying material into the system. Some filter-driers are equipped with a sight-glass indicator, as shown in figure 6-28. A dehydrator is similar to a filter-drier, except that it mainly removes moisture.

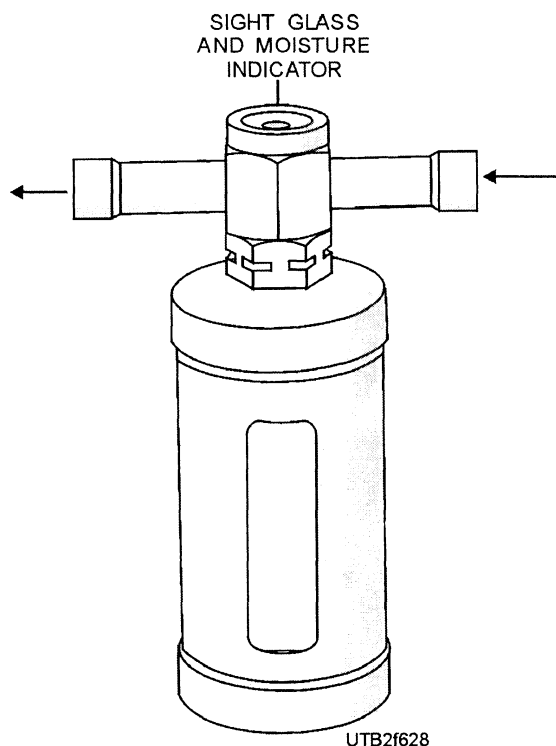

Figure 6-28.—A liquid line filter-drier with sight-glass indicator.

SIGHT-FLOW INDICATOR.—The sight-flow indicator, also known as a sight glass (fig. 6-29), is a special fitting provided with a gasketed glass, single or double port, and furnished with or without seal caps for protection when not in use. The double-port unit permits the use of a flashlight background. The refrigerant may be viewed passing through the pipe to determine the presence and amount of vapor bubbles in the liquid that would indicate low refrigerant or unfavorable operating conditions. Some filter-driers are equipped with built-in sight-flow indicators, as shown in figure 6-29.

SUCTION LINE.—Suction pressure regulators are sometimes placed between the outlet of the evaporator and the compressor to prevent the evaporator pressure from being drawn down below a predetermined level despite load fluctuations. These regulators are usually installed in systems that require a higher evaporator temperature than usual.

PRESSURE CONTROL SWITCHES.—Pressure control switches (fig. 6-30), often called low-pressure cutouts, are essentially a single-pole, single-throw electrical switch and are mainly used to control starting and stopping of the compressor. The suction pressure acts on the bellows of the power element of the switch and produces movement of a lever mechanism operating electrical contacts. A rise in pressure closes the switch contacts and thereby completes the circuit of the motor controller, which, in turn, starts the compressor automatically. As the operation of the compressor gradually decreases the suction pressure, the movement of the switch linkage

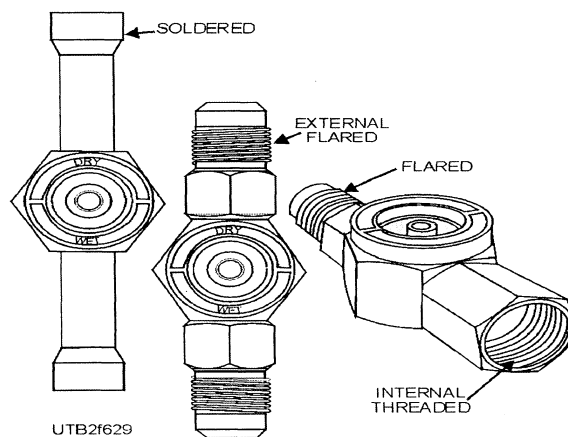

Figure 6-29.—Sight-flow indicators with different types of connections.

reverses until the contacts are separated at a pre-determined low-suction pressure, thus breaking the motor controller circuit and stopping the compressor.

SUCTION LINE FILTER-DRIER.—Some systems include a low-side filter-drier (fig. 6-31) at the compressor end of the suction line. The filter-drier used in the suction line should offer little resistance to flow of the vaporized refrigerant, as the pressure difference between the pressure in the evaporator and the inlet of the compressor should be small. These filter-driers function to remove dirt, scale, and moisture from the refrigerant before it enters the compressor.

GAUGES AND THERMOMETERS.—Between the suction line stop valve and the compressor, a pressure gauge and thermometer may be provided to show the suction conditions at which the compressor is operating. The thermometer shows a higher temperature than the temperature corresponding to the suction pressure indicated on the gauge, because the refrigerant vapor is superheated during its passage from the evaporator to the compressor.

ACCUMULATORS AND OIL SEPARATORS.—Liquid refrigerant must never be allowed to enter the compressor. Liquids are noncompressible; in other words, their volume remains the same when compressed. An accumulator (fig. 6-32) is a small tank accessory; that is, a safety device designed to prevent liquid refrigerant from flowing into the suction line and into the compressor. A typical accumulator has an

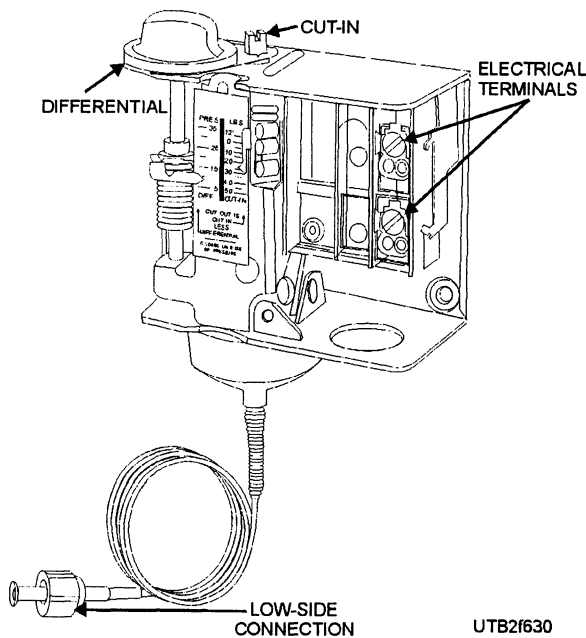

Figure 6-30.—Pressure type cut-in, cutout control switch.

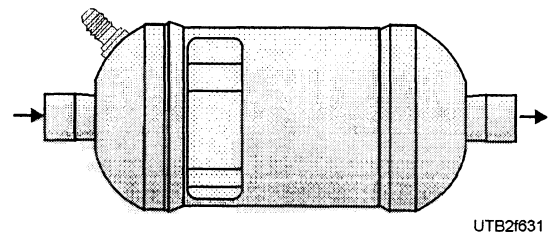

Figure 6-31.—A suction line filter-drier.

outlet at the top. Any liquid refrigerant that flows into the accumulator is evaporated, and then the vapor will flow into the suction line to the compressor.

Oil from the compressor must not move into the rest of the refrigeration system. Oil in the lines and evaporator reduces the efficiency of the system. An oil separator (fig. 6-33) is located between the compressor discharge and the inlet of the condenser. The oil separator consists of a tank or cylinder with a series of baffles and screens, which collect the oil. This oil settles to the bottom of the separator. A float arrangement operates a needle valve, which opens a return line to the compressor crankcase.

- Q7. What are the three types of compressors used in refrigeration systems?
- Q8. What is the difference between the internal and external bellows crankshaft seal?
- Q9. What are the two drawbacks of a hermetic compressor?
- Q10. What are the two primary types of evaporators?
- Q11. A capillary tube-metering device is most commonly used on what type of refrigeration equipment?
- Q12. What is the function of a sight-flow indicator?

REFRIGERANTS

Learning Objective: Understand and identify classification of common refrigerants and their application. Understand the requirements for ozone protection and the Clean Air Act.

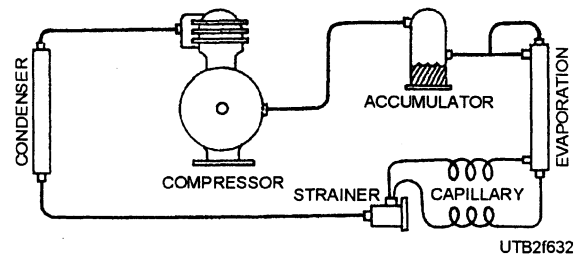

Figure 6-32.—Accumulator location.

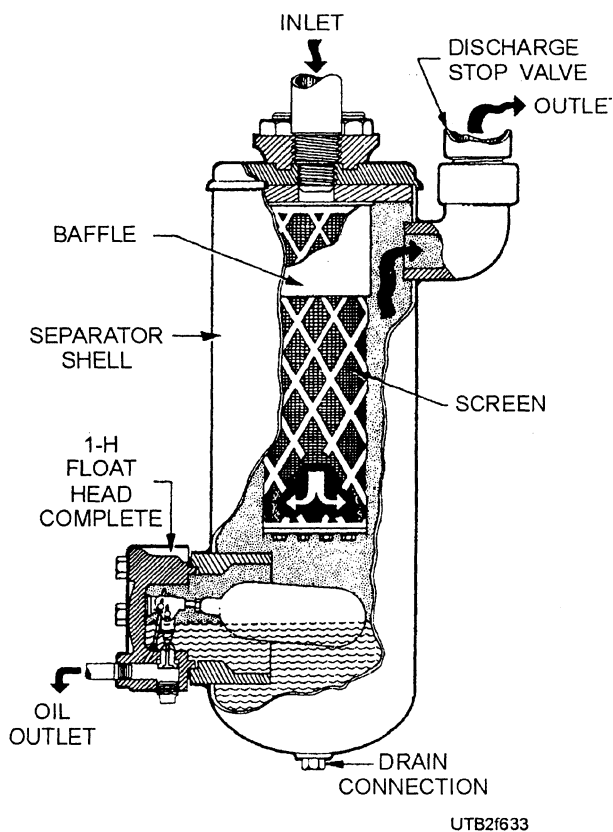

Figure 6-33.—A cutaway view of an oil separator.

Refrigerants are fluids that change their state upon the application or removal of heat within a system and, in this act of change, absorb or release heat to or from an area or substance. Many different fluids are used as refrigerants. In recent years, the most common has been air, water, ammonia, sulfur dioxide, carbon dioxide, and methylchloride.

Today, there are three specific types of refrigerants used in refrigeration and air-conditioning systems—(1) Chlorofluorocarbons or CFCs, such as R-11, R-12, and R-114; (2) Hydrochlorofluorocarbons or HCFCs, such as R-22 or R-123; and (3) Hydrofluorocarbons or HFCs, such as R-134a. All these refrigerants are "halogenated," which means they contain chlorine, fluorine, bromine, astatine, or iodine.

Refrigerants, such as Dichlorodifluoromethane (R-12), Monochlorodifluoromethane (R-22), and Refrigerant 502 (R-502), are called PRIMARY REFRIGERANTS because each one changes its state upon the application or absorption of heat, and, in this act of change, absorbs and extracts heat from the area or substance.

The primary refrigerant is so termed because it acts directly upon the area or substance, although it

may be enclosed within a system. For a primary refrigerant to cool, it must be placed in a closed system in which it can be controlled by the pressure imposed upon it. The refrigerant can then absorb at the temperature ranges desired. If a primary refrigerant were used without being controlled, it would absorb heat from most perishables and freeze them solid.

SECONDARY REFRIGERANTS are substances, such as air, water, or brine. Though hot refrigerants in themselves, they have been cooled by the primary refrigeration system; they pass over and around the areas and substances to be cooled; and they are returned with their heat load to the primary refrigeration system. Secondary refrigerants pay off where the cooling effect must be moved over a long distance and gastight lines cost too much.

Refrigerants are classified into groups. The National Refrigeration Safety Code catalogs all refrigerants into three groups—Group I – safest of the refrigerants, such as R-12, R-22, and R-502; Group II – toxic and somewhat flammable, such as R-40 (Methyl chloride) and R-764 (Sulfur dioxide); Group III – flammable refrigerants, such as R-170 (Ethane) and R-290 (Propane).

R-12 DICHLORODIFLUOROMETHANE (CCl₂F₂)

Dichlorodifluoromethane, commonly referred to as R-12, is colorless and odorless in concentrations of less than 20 percent by volume in air. In higher concentrations, its odor resembles that of carbon tetrachloride. It is nontoxic, noncorrosive, nonflammable, and has a boiling point of -21.7°F (-29°C) at atmospheric pressure.

WARNING

Because of its low-boiling point at atmospheric pressure, it prevents liquid R12 from contacting the eyes because of the possibility of freezing.

One hazard of R-12 as a refrigerant is the health risk should leakage of the vapor come into contact with an open flame of high temperature (about 1022°F) and be decomposed into phosgene gas, which is highly toxic. R-12 has a relatively low latent heat value, and, in smaller refrigerating machines, this is an advantage. R-12 is a stable compound capable of undergoing the physical changes without decomposition to which it is

commonly subjected in service. The cylinder code color for R-12 is white.

R-22 MONOCHLORODIFLUOROMETHANE (CHClF₂)

Monochlorodifluoromethane, normally called R-22, is a synthetic refrigerant developed for refrigeration systems that need a low-evaporating temperature, which explains its extensive use in household refrigerators and window air conditioners. R-22 is nontoxic, noncorrosive, nonflammable, and has a boiling point of -41°F at atmospheric pressure. R-22 can be used with reciprocating or centrifugal compressors. Water mixes readily with R-22, so larger amounts of desiccant are needed in the filter-driers to dry the refrigerant. The cylinder code color for R-22 is green.

R-502 REFRIGERANT (CHClF₂/CClF₂CF₃)

R-502 is an azeotropic mixture of 48.8 percent R-22 and 51.2 percent R-115. Azeotropic refrigerants are liquid mixtures of refrigerants that exhibit a constant maximum and minimum boiling point. These mixtures act as a single refrigerant. R-502 is noncorrosive, nonflammable, practically nontoxic, and has a boiling point of -50°F at atmospheric pressure. This refrigerant can only be used with reciprocating compressors. It is most often used in refrigeration applications for commercial frozen food equipment, such as frozen food walk-in refrigerators, frozen food display cases, and frozen food processing plants. The cylinder color code for R-502 is orchid.

R-134a TETRAFLUOROETHANE (CH₂FCF₃)

R-134a, tetrafluoroethane, is very similar to R-12, the major difference is that R-134a has no harmful influence on the ozone layer of the earth's atmosphere and is a replacement for R-12 applications. Noncorrosive, nonflammable, and nontoxic, it has a boiling point of -15°F at atmospheric pressure. Used for medium-temperature applications, such as air conditioning and commercial refrigeration, this refrigerant is now used in automobile air-conditioners. The cylinder color code for R-134a is light (sky) blue.

ADDITIONAL REFRIGERANTS

In addition to the previously mentioned refrigerants, other less common refrigerants are used in a variety of applications.

R-717 Ammonia (NH₃)

Ammonia, R-717, is commonly used in industrial systems. It has a boiling point of -28°F at atmospheric pressure. This property makes it possible to have refrigeration at temperatures considerably below zero without using pressure below atmospheric in the evaporator. Normally it is a colorless gas, is slightly flammable, and, with proper portions of air, it can form an explosive mixture, but accidents are rare. The cylinder color code for R-717 is silver.

R-125 Pentafluoroethane (CHClF₃)

Pentafluoroethane, R-125, is a blend component used in low- and medium-temperature applications. With a boiling point of -55.3°F at atmospheric pressure, R-125 is nontoxic, nonflammable, and noncorrosive. R-125 is one replacement refrigerant for R-502.

All refrigerants have their own characteristics. It is extremely important to charge a system with the refrigerant specified. Use of an incorrect refrigerant can lead to reduced efficiency, mechanical problems, and dangerous conditions.

OZONE PROTECTION AND THE CLEAN AIR ACT

Several scientific studies conducted in the 1970s showed that chlorine was a leading cause of holes in the ozone. In 1987, 30 countries signed the Montreal Protocol, which mandated the phase out of the production, and eventual use, of all harmful CFCs. In 1990, the most significant piece of legislation affecting the air conditioning and refrigeration industry, the Clean Air Act, was passed. Regulated by the Environmental Protection Agency (EPA), Title VI of the Clean Air Act states fully halogenated refrigerants (CFCs) will be phased out. It also calls for the phase out of HCFCs by the year 2030. Both of these types of refrigerants adversely affect the atmosphere, and as of July 1992, it is illegal to discharge refrigerant to the atmosphere. The production of R-12 was discontinued in December 1995, and the production of R-11, R-113, R-114, and R-115 is scheduled to be discontinued by

January 2000. Depending on the rate of depletion of the ozone layer, these timetables could be accelerated.

As a result of the Clean Air Act of 1990, there has been a determined effort by manufacturers to develop alternative refrigerants to replace those to be discontinued. CFCs, R-11, and R-12, primarily used in chillers, residential, and automotive refrigeration, can be substituted with HCFC R-123 and HFC R-134a. Future replacements include HCFC R-124 in place of CFC, R-114, in marine chillers, and HFC R-125, in place of CFC R-502, used in stores and supermarkets.

These replacement refrigerants have slightly different chemical and physical properties; thus they cannot just be "dropped" into a system designed to use CFCs. Loss of efficiency and improper operation could be the result. When changing the refrigerant in an existing system, parts of the system specifically designed to operate with a CFC refrigerant may need to be replaced or retrofitted to accommodate the new refrigerant.

Q13. What are CFCs and HCFCs?

Q14. What can happen if improper refrigerant is used in a refrigeration system?

Q15. What types of refrigerants are to be phased out by the Clean Air Act in 2030?

Q16. What refrigerant has been developed to replace R-12?

REFRIGERANT SAFETY

Learning Objective: Recall the safety requirements for handling and storage of refrigerants and refrigerant cylinders.

Safety is always paramount and this is especially true when you are working with refrigerants. Major safety concerns are discussed in this section.

PERSONAL PROTECTION

Since R-12, R-22, and R-502 are nontoxic, you will not have to wear a gas mask; however, you must protect your eyes by wearing splashproof goggles to guard against liquid refrigerant freezing the moisture of your eyes. When liquid R-12, R-22, and R-502 contact the eyes, get the injured person to the medical officer at once. Avoid rubbing or irritating the eyes. Give the following first aid immediately:

- Drop sterile mineral oil into the eyes and irrigate them.
- Wash the eyes when irrigation continues with a weak boric acid solution or a sterile salt solution not to exceed 2 percent salt.

Should the refrigerant contact the skin, flush the affected area repeatedly with water. Strip refrigerant-saturated clothing from the body, wash the skin with water, and take the patient immediately to the dispensary. Should a person be overcome in a space which lacks oxygen due to a high concentration of refrigerant, treat the victim as a person who has experienced suffocation; render assistance through artificial respiration.

HANDLING AND STORAGE OF REFRIGERANT CYLINDERS

Handling and storage of refrigerant cylinders are similar to handling and storage of any other type of compressed gas cylinders. When handling and storing cylinders, keep the following rules in mind:

- Open valves slowly; never use any tools except those approved by the manufacturer.
- Keep the cylinder cap on the cylinder unless the cylinder is in use.
- When refrigerant is discharged from a cylinder, immediately weigh the cylinder.
- Record the weight of the refrigerant remaining in the cylinder.
- Ensure only regulators and pressure gauges designed for the particular refrigerant in the cylinder are used.
- Do not use different refrigerants in the same regulator or gauges.
- Never drop cylinders or permit them to strike each other violently.
- Never use a lifting magnet or a sling. A crane may be used when a safe cradle is provided to hold the cylinders.
- Never use cylinders for any other purpose than to carry refrigerants.
- Never tamper with safety devices in the cylinder valves.
- Never force connections that do not fit. Ensure the cylinder valve outlet threads are the same as what is being connected to it.

- Never attempt to alter or repair cylinders or valves.
- Cylinders stored in the open must be protected from extremes of weather and direct sunlight. A cylinder should never be exposed to temperature above 120°F.
- Store full and empty cylinders apart to avoid confusion.
- Never store cylinders near elevators or gangways.
- Never store cylinders near highly flammable substances.
- Never expose cylinders to continuous dampness, salt water, or spray.

Q17. Goggles are not required when working with refrigerants. True/False

Q18. How often should you weigh a refrigerant cylinder?

Q19. Why are full and empty refrigerant cylinders stored separately?

REFRIGERATION EQUIPMENT

Learning Objective: Understand and recognize the basic types of commercial and domestic refrigeration equipment.

Refrigeration equipment can be classified as either self-contained or remote units. Self-contained equipment houses both the insulated storage compartments (refrigerated), in which the evaporator is located, and an uninsulated compartment (nonrefrigerated), in which the condensing unit is located, in the same cabinet. This type of equipment can be designed with a hermetically sealed, semisealed, or an open condensing unit. These units are completely assembled and charged at the factory and come ready for use with little or no installation work. Self-contained refrigerating equipment includes such equipment as domestic refrigerators and freezers, water coolers, reach-in and walk-in refrigerators, small cold-storage plants, and ice plants.

Remote refrigerating equipment has the condensing unit installed in a remote location from the main unit. These types of units are used where the heat liberated from the condenser cannot enter the space where the unit is installed or space is limited for installation.

REACH-IN REFRIGERATORS

Reach-in refrigerators have a storage capacity of 15 cubic feet or greater. At Navy installations, they are used to store perishable foods in galleys and messes. Also, at Navy hospitals and medical clinics they are used to store biologicals, serums, and other medical

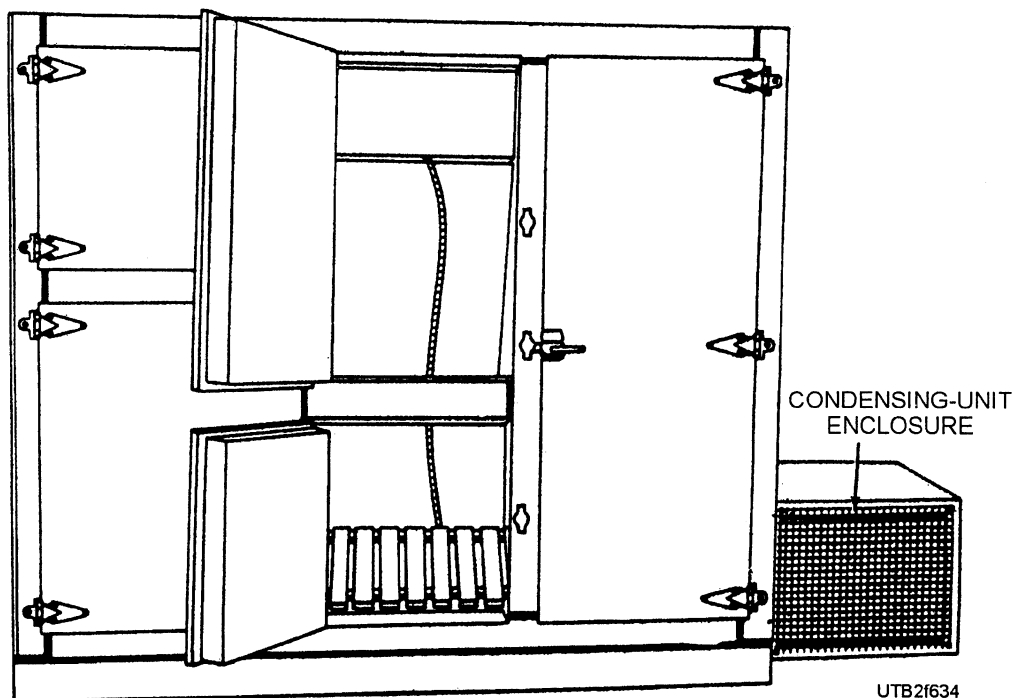
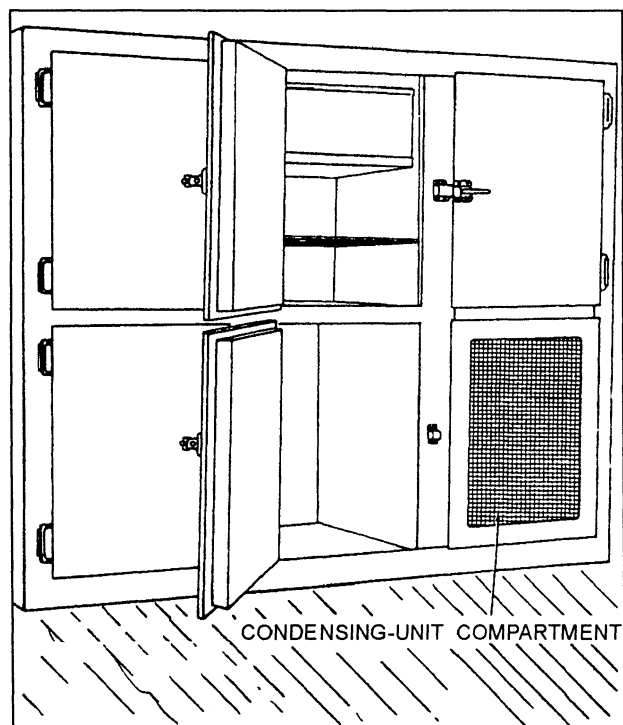

Figure 6-34.—A reach-in refrigerator with a remote condensing unit.

supplies requiring temperatures between 30°F and 45°F. Standard-size units most frequently used are those with storage capacities between 15 and 85 cubic feet. Figure 6-34 shows a typical reach-in refrigerator with a remote (detached) condensing unit.

Exterior finishes for reach-in refrigerators are usually of stainless steel, aluminum, or vinyl, while the interior finishes are usually metal or plastic, and the refrigerator cabinet is insulated with board or batten type polystyrene or urethane. Reach-in refrigerators are normally self-contained, with an air-cooled condenser, but in larger refrigerators, with remote condensers, water-cooled condensers are sometimes used. A typical self-contained unit is shown in figure 6-35. The evaporator is mounted in the center of the upper portion of the food compartment. In operation, warm air is drawn by the fan into the upper part of the unit cooler, where it passes over the evaporator coils, is cooled, and then is discharged at the bottom of the cooler. The air then passes up through the interior and around the contents of the refrigerator. The cycle is completed when the air again enters the evaporator. The low-pressure control is set to operate the evaporator on a self-defrosting cycle, and temperature is thus control led. Another type of control system uses both temperature and low-pressure control or defrost on each cycle. The evaporator fan is wired for continuous operation within the cabinet.



UTB2f635

Figure 6-35.—A self-contained reach-in refrigerator.

Evaporators in reach-in refrigerators are generally the unit cooler type with dry coils (fig. 6-36). In smaller capacity refrigerators, ice-making coils, similar to those used in domestic refrigerators, are often used as well as straight gravity coils. R-12 and R-502 are normally used in these units.

WALK-IN REFRIGERATORS

Walk-in refrigerators are normally larger than reach-in types and are either built-in or prefabricated sectional walk-in units. They are made in two

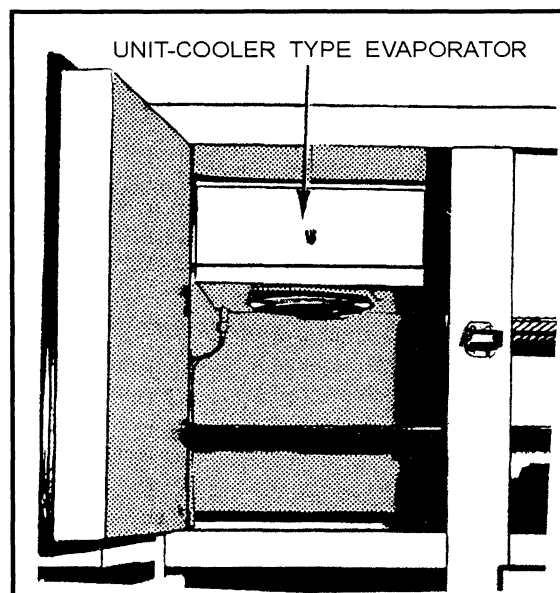

A

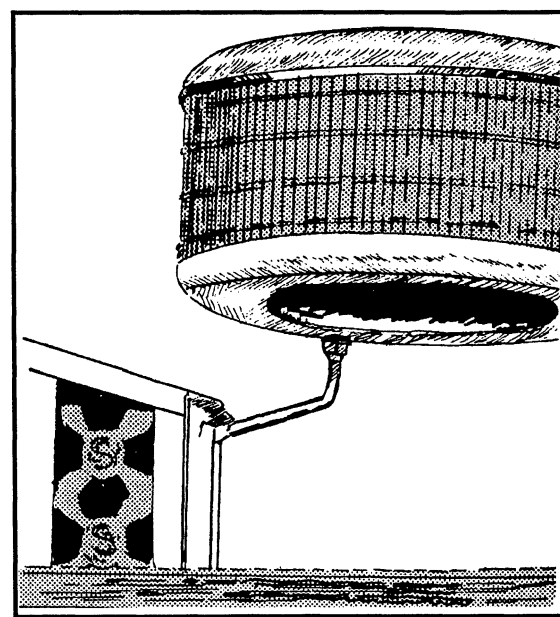

B

UTB2f636

Figure 6-36.—A. Unit cooler in a reach-in refrigerator; B. Dome cooler in a reach-in refrigerator.

types—one for bulk storage of fresh meats, dairy products, vegetables, and fruits requiring a temperature from 35°F to 38°F and the other for the storage of frozen food at temperatures of 10°F or below. The 35°F to 38°F refrigerators are built and shipped in sections and assembled at the location they are installed. They can be taken apart, moved, and reassembled in another area if needed. Standard-size coolers can be from 24 square feet up to 120 square feet in floor area. A walk-in refrigerator with reach-in doors is shown in figure 6-37.

The exterior and interiors of these units are normally galvanized steel or aluminum. Vinyl, porcelain, and stainless steel are also used. Most walk-in refrigerators use rigid polyurethane board, batten, or foamed insulation between the inner and outer walls. For storage temperatures between 35°F to 40°F, 3 to 4 inches of insulation is generally used. For low-temperature applications, 5 inches or more of insulation is used. These refrigerators are equipped with meat racks and hooks to store meat carcasses. Walk-in refrigerators also have a lighting system inside the refrigerator compartment. Most systems have the compressor and condenser outside the main structure and use either a wall-mounted forced-air or gravity-type evaporator that is separated from the main part of the cabinet interior by a vertical baffle.

The operation of the walk-in refrigerator is similar to that of the reach-in units. The evaporator must have

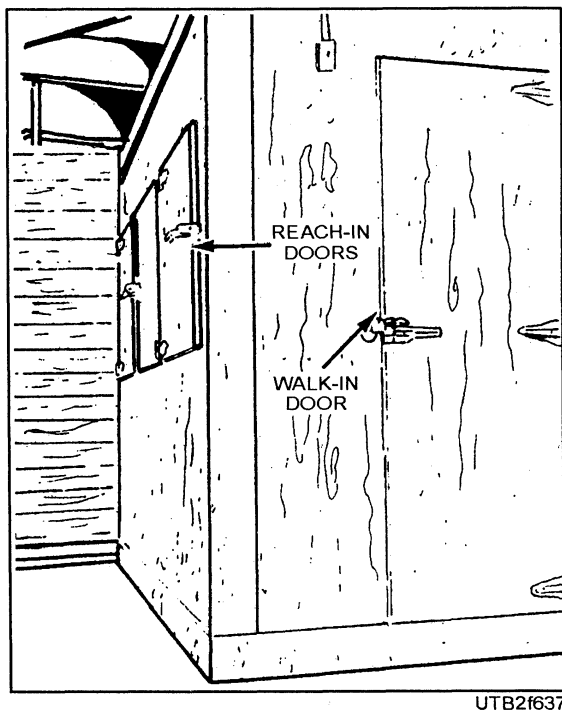

Figure 6-37.—A walk-in refrigerator with reach-in doors.

sufficient capacity (Btu per hour) to handle the heat load from infiltration and product load.

DOMESTIC REFRIGERATORS

Domestic refrigerators are used in most facilities on a Navy installation. Most domestic refrigerators are of two types—either a single door fresh food refrigerator or a two-door refrigerator-freezer combination, with the freezer compartment on the top portion of the cabinet, or a vertically split cabinet (side-by-side), with the freezer compartment on the left side of the cabinet. They are completely self-contained units and are easy to install. Most refrigerators use R-22 refrigerant, normally maintaining temperatures of 0°F in the freezer compartment and about 35°F to 45°F in the refrigerator compartment. The Utilitiesman must be able to perform various duties in the maintenance and repair of domestic refrigerators, water coolers, and ice machines at Navy activities. This section provides information to aid you in handling some of the more common types of troubles. But let us remind you that the information given here is intended as a general guide and should, therefore, be used with the manufacturer's detailed instructions. For troubleshooting guidance, see table Y in appendix II at the back of this TRAMAN.

Single Door Fresh Food Refrigerator

A single door fresh food refrigerator (fig. 6-38) consists of an evaporator placed either across the top or in one of the upper corners of the cabinet. The

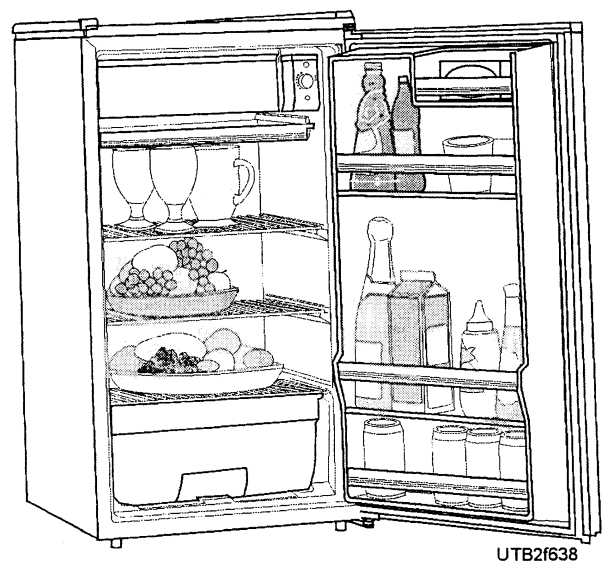

Figure 6-38.—Single door fresh food refrigerator.

condenser is on the back of the cabinet or in the bottom of the cabinet below the hermetic compressor. During operation, the cold air from the evaporator flows by natural circulation through the refrigerated space. The shelves inside the cabinet are constructed so air can circulate freely past the ends and sides, eliminating the need for a fan. This refrigerator has a manual defrost, which requires that the refrigerator be turned off periodically (usually overnight) to enable the buildup of frost on the evaporator to melt. Both the outside and inside finish is usually baked-on enamel. Porcelain enamel is found on steel cabinet liners. The interior of the unit contains the shelves, lights, thermostats, and temperature controls.

Two-Door Refrigerator-Freezer Combination

The two-door refrigerator-freezer combination is the most popular type of refrigerator. It is similar to the fresh food refrigerators in construction and the location of components except it sometimes has an evaporator for both the freezer compartment and the refrigerator compartment. Also, if it is a frost-free unit, the evaporators are on the outside of the cabinet. Because of the two separate compartments (refrigerator-freezer) and the larger capacity, these types of refrigerators use forced air (fans) to circulate the air through the inside of both compartments. The two-door refrigerator also has one of the following three types of evaporator defrost systems: manual defrost, automatic defrost, or frost-free.

There are two types of automatic defrosting: the hot gas system or the electric heater system. The hot gas system, through the use of solenoid valves, uses the heat in the vapor from the compressor discharge line and the condenser to defrost the evaporator. The other system uses electric heaters to melt the ice on the evaporator surface.

A frost-free refrigerator-freezer (fig. 6-39) has the evaporator located outside the refrigerated compartment. On the running part of the cycle, air is drawn over the evaporator and is forced into the freezer and refrigerator compartments by a fan. On the off part of the cycle, the evaporators automatically defrost.

Refrigerator-freezer cabinets are made of pressed steel with a vinyl or plastic lining on the interior wall surfaces and a lacquer exterior finish. Most domestic refrigerators have urethane foam or fiber glass insulation in the cabinet walls. The side-by-side refrigerator-freezer arrangement has a number of features not found in other refrigerators. In addition to

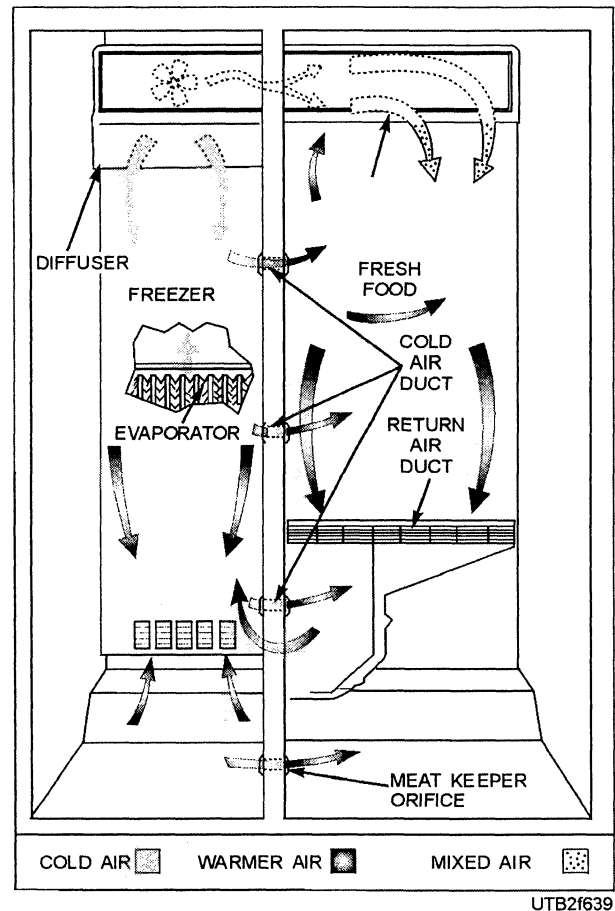

Figure 6-39.—Frost-free refrigerator airflow diagram.

the automatic icemaker in the freezer compartment, it has an option for a cold water dispenser, a cube or crushed ice dispenser, and a liquid dispenser built into the door.

WATER COOLERS AND ICE MACHINES

Water coolers provide water for drinking at a temperature under 50°F. Two types of water coolers are instantaneous and storage. The instantaneous type only cools water when it is being drawn; the storage type maintains a reservoir of cooled water. One instantaneous method used places coils in a flooded evaporator through which the water flows. A second instantaneous method uses double coils with water flowing through the inner coil with refrigerant flowing in the space between the inner coil and the outer coil. A third instantaneous method is to coil the tubing in a water storage tank. This allows refrigerant to flow through it (fig. 6-40).

Water coolers are of two basic designs—wall mounted or floor mounted. Both types are the same in construction and operation; the only difference is in the

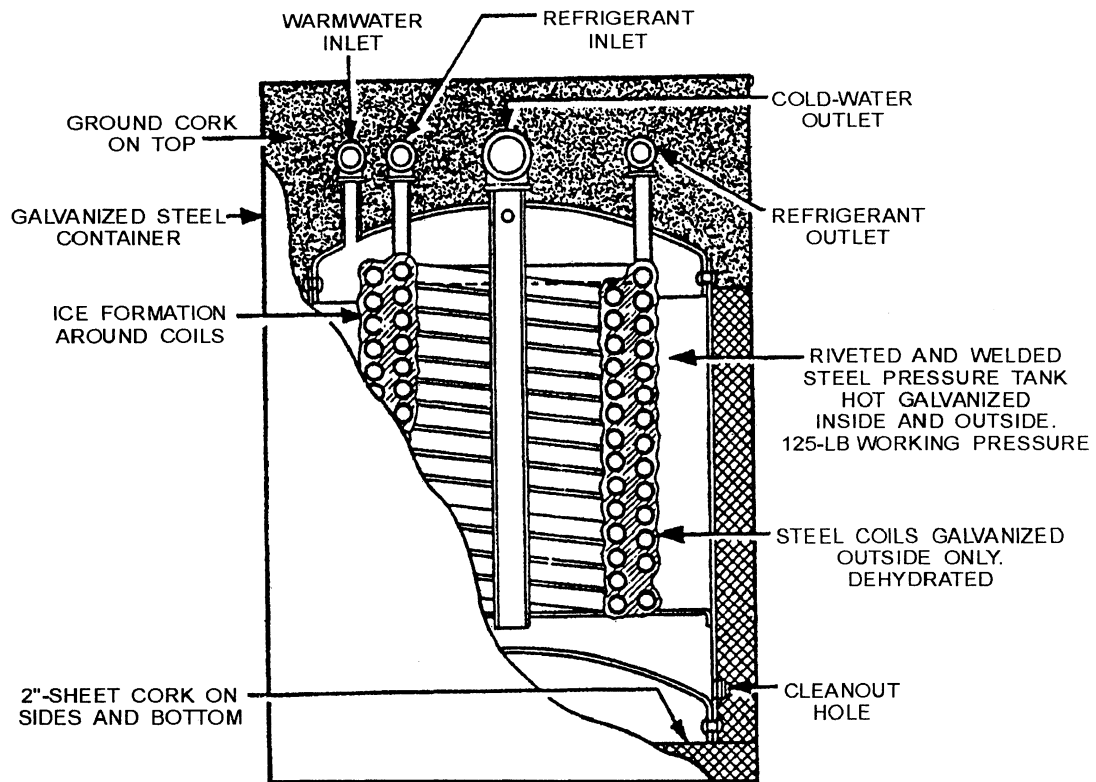

UTB2f640

Figure 6-40.—Storage type of water cooler.

method of installation. Water cooler cabinets have a sheet metal housing attached to a steel framework. The condenser and hermetic compressor are located in the housing base, and the evaporator is located in the cabinet depending on its type of evaporator, but normally under the drain basin. Most water coolers use a heat exchanger or precooler, which pre-cools the fresh water line to the evaporator, reducing cooling requirements for the evaporator. A thermostat, which is manually set and adjusted, is located in the cooler housing close to the evaporator.

Automatic ice machines, similar to the units shown in figures 6-41 and 6-42, are often used in galleys, barracks, gymnasiums, and other public areas. Ice machines are self-contained, automatic machines, ranging from a small unit producing 50 pounds of ice per day to a commercial unit producing 2,400 pounds of ice per day. The primary difference in the design of these machines is the evaporator. They automatically control water feed to the evaporator, freeze the water in an ice cube mold, heat the mold and empty the ice into a storage bin, and shut down when the storage bin is full. Floats and solenoids control water flow, and switches operate the storing action when ice is made. Electrical heating elements, hot water, hot gas defrosting, or mechanical devices remove the ice from the freezing

surfaces depending on the unit. Figures 6-43 and 6-44 show the freezing and defrost cycle of a typical ice cube machine. In recent years, many companies have begun to manufacture their units to use HFC R-404a refrigerant instead of HCFC R-22.

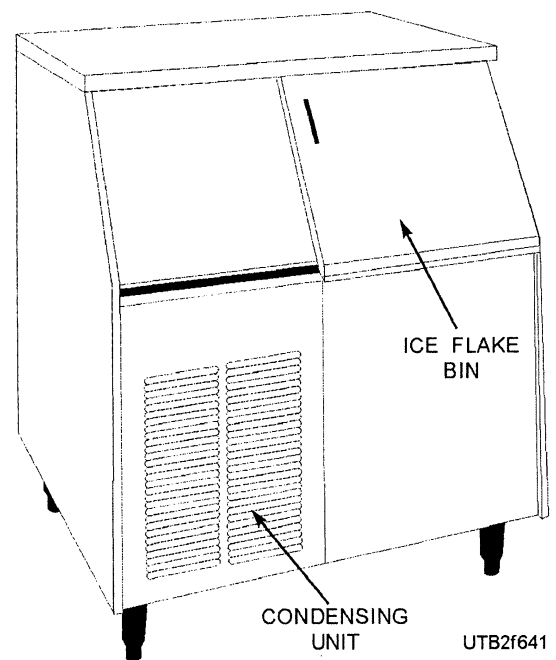

UTB2f641

Figure 6-41.—Flake or chipped-ice machine.

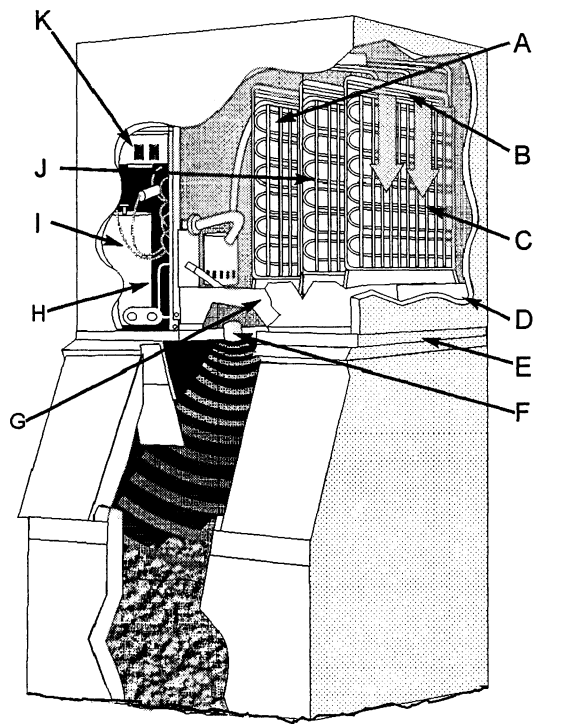

- | | |
|-----------------------------|----------------------------------|
| A. Modular evaporator plate | G. Frontal access for service |
| B. Water distribution tubes | H. Suction line accumulator |
| C. Evaporator plate | I. Compressor - R-22 refrigerant |
| D. Insulated cabinet | J. Water control |
| E. Base | K. Adjustable bin control |
| F. Sonar bin control | |

UTB2f642

Figure 6-42.—A cutaway view of an automatic ice machine.

- Q20. What design factor makes remote refrigeration equipment different from self-contained equipment?
- Q21. Reach-in refrigerators are operated at a temperature that falls within what range, in degrees Fahrenheit?
- Q22. Reach-in refrigeration units are equipped with what type of evaporator?
- Q23. Why are walk-in refrigerators manufactured and constructed in sections?
- Q24. Domestic refrigerators come in what two design configurations?
- Q25. What are the two types of automatic defrosting in the two-door refrigerator-freezer combination unit?
- Q26. What component of a water cooler pre-cools the fresh water line to the evaporator?

Q27. What design factor is the primary difference in the different types of ice machines?

INSTALLATION OF REFRIGERATION EQUIPMENT

Learning Objective: Recall refrigeration requirements and the types of installation for refrigeration equipment.

Utilitiesman are often tasked to installation refrigeration systems. Therefore, it is important for you to understand the basic requirements applicable to the installation of the various types of the equipment.

When installing a refrigeration or air-conditioning plant, you must not allow dirt, scale, sand, or moisture to enter any part of the refrigerant system. Since air contains moisture, its entrance into the circuit should be controlled as much as possible during installation. Most maintenance problems come from careless erection and installation. All openings to the refrigerant circuit—piping, controls, compressor, condensers, and so on—must be adequately sealed when work on them is not in progress. The R-12 refrigerant is a powerful solvent that readily dissolves foreign matter and moisture that may have entered the system during installation. This material is soon carried to the operating valves and the compressor. It becomes a distinct menace to bearings, pistons, cylinder walls, valves, and the lubricating oil. Scoring of moving parts frequently occurs when the equipment is first operated, starting with minor scratches that increase until the operation of the compressor is seriously affected.

Under existing specifications, copper tubing and copper piping needed for installation should be cleaned, deoxidized, and sealed. When there is a question about cleanliness of tubing or piping to be used, each length of pipe should be thoroughly blown out. Use a strong blast of dry air when blowing out, and clean the tubing with a cloth swab attached to copper wire pulled back and forth in the tube until it is clean and shiny. Then the ends of the tubes should be sealed until connected to the rest of the system.

EFFECTS OF MOISTURE

As little as 15 to 20 parts of moisture per million parts of R-12 can cause severe corrosion in a system. The corrosion results from hydrochloric acid formed by R-12 in contact with water. A chemical reaction takes place between the acid and the iron and copper in

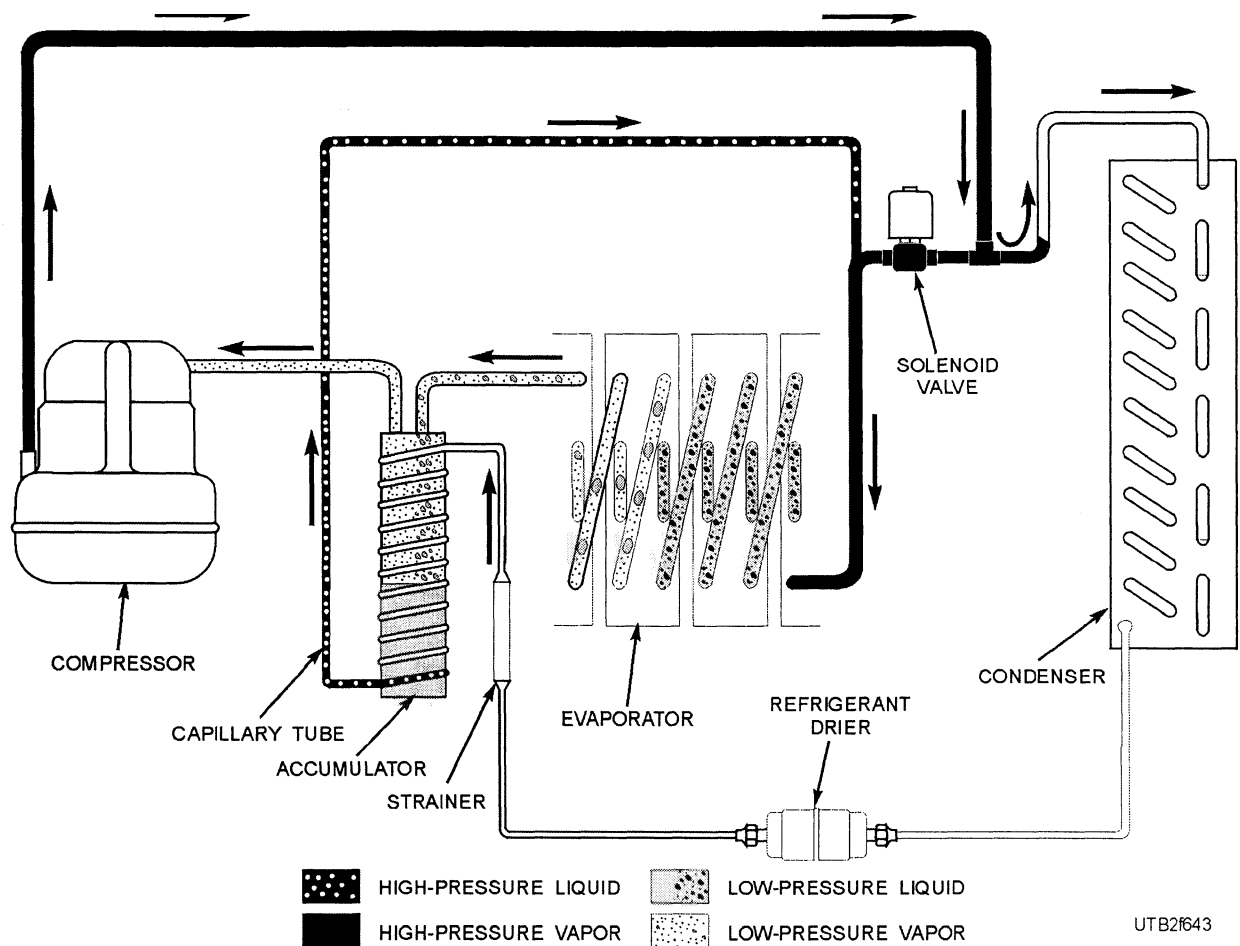

Figure 6-43.—An ice cube machine refrigeration cycle during the freezing process.

the system to form corrosion products. A strong acid combined with high discharge and compressor temperature can cause decomposition of lubricating oil and produce a sludge of breakdown products. Either the corrosion or the oil breakdown products can plug valves, strainers, and dryers and cause a serious casualty.

NOTE: The formation of ice from a minute quantity of moisture in expansion valves and capillary tubes can occur when operating below 32°F.

LOCATION OF EQUIPMENT

Adequate space should always be left around major portions of equipment for servicing purposes; otherwise, the equipment must be moved after installation so serviceable parts are accessible (figs. 6-45 and 6-46). Compressors require overhead clearance for removal of the head, discharge valve plate, and pistons with side clearance to permit removal of the flywheel and crankshaft where necessary. Water-cooled condensers require a free

area equal to the length of the condenser at one end to provide room for cleaning tubes, installing new tubes, or removal of the condenser tube assembly. Space is needed for servicing valves and accessory equipment. Service openings and inspection panels on unitary equipment require generally at least 18 inches of clearance for removal of the panel. Air-cooled condensing units should be placed in a location that permits unrestricted flow of air for condensing, whether the condenser is in a unitary piece of equipment or separate. Inadequate ventilation around air-cooled condensers can cause overloading of the motor and loss of capacity.

REFRIGERANT PIPING

Certain general precautions for the installation of refrigerant lines should be followed. When the receiver is above the cooling coil, the liquid line should be turned up before going down to the evaporator. This inverted loop prevents siphoning of the liquid from the receiver over into the cooling coil through an open or leaking expansion valve during compressor

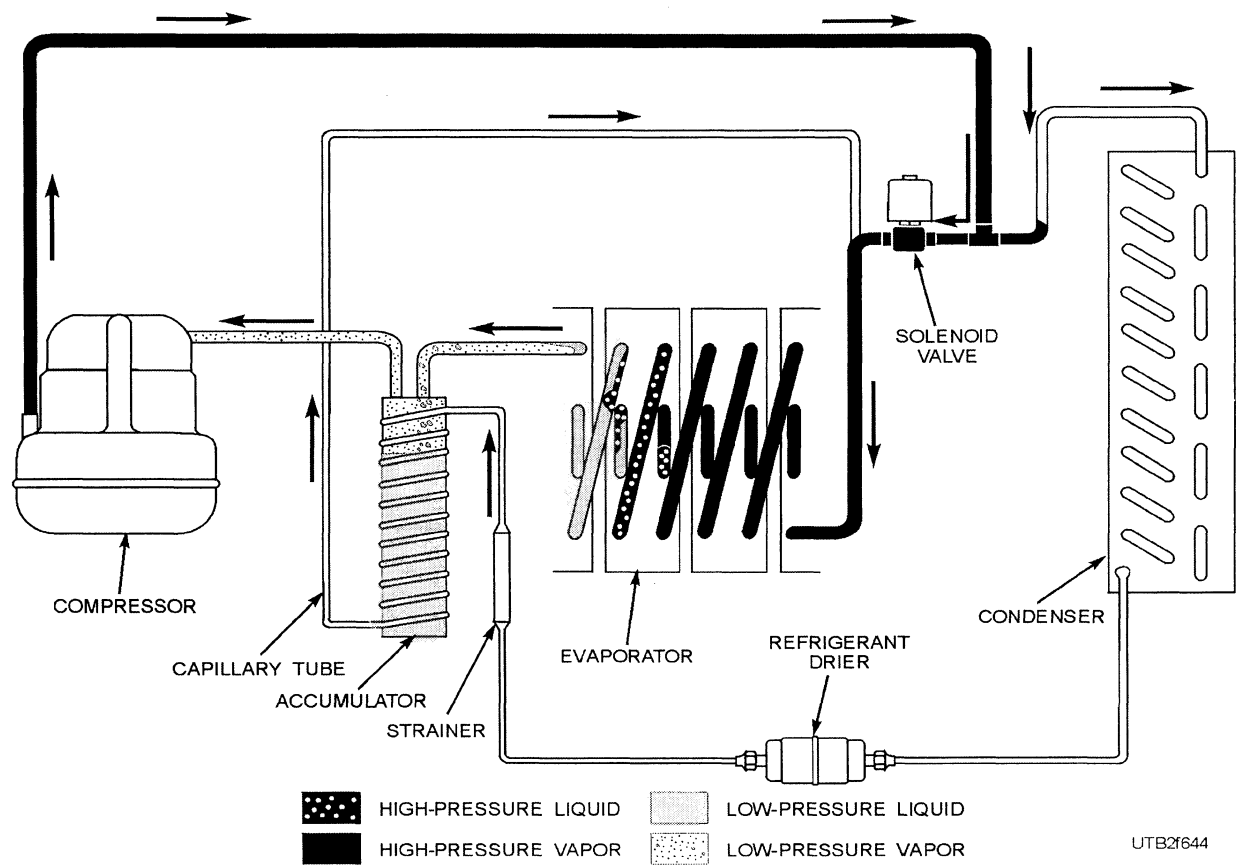

Figure 6-44.—The defrost cycle of an ice cube machine.

shutdown periods. If siphoning starts, the liquid refrigerant flashes into a gas at the top of the loop, breaking the continuity of the liquid volume and stopping the siphoning action. Where the cooling coils and compressors are on the same level, both the suction and liquid lines should be run to the overhead and then down to the condensing unit, pitching the suction line toward the compressor to ease oil return. On close-coupled installations, running both lines up to the overhead helps to eliminate vibration strains as well as provide the necessary trap at the cooling coil.

Prepare pipe and fittings with care, particularly when cutting copper tubing or pipe to prevent filings or cuttings from entering the pipe. The small particles of copper should be completely removed since the finely divided copper may pass through the suction strainer. The tube should be cut square, and all burrs and dents should be removed to prevent internal restrictions and to permit proper fit with the companion fittings. If a hacksaw is used to cut, a fine-toothed blade should be used, preferably 32 teeth per inch. The use of a hacksaw should be avoided whenever possible. When

making silver-solder joints, brighten up the ends of the tubing or pipe with a wire brush or crocus cloth to make a good bond. Do not use sandpaper, emery cloth, or steel wool for this cleansing, as this material may enter the system and cause trouble.

Acid should never be used for soldering, nor should flux be used if its residue forms an acid. Use flux sparingly so no residue will enter inside the system and eventually be washed back to the compressor crankcase. If tubing and fittings are improperly fitted because of distortion, too much flux, solder, and brazing material may enter the system.

The temperature required to solder or braze pipe joints causes oxidation within the tubing. The oxidation eventually will be removed by the refrigerant flow after the system is in operation. The oxide breaks up into a fine powder to contaminate the lubricant in the compressor and to plug strainers and driers. To eliminate this possibility, provide a neutral atmosphere within the tube being soldered or brazed. Use gas-bled nitrogen through the tubing during soldering or brazing and for a sufficient time after the

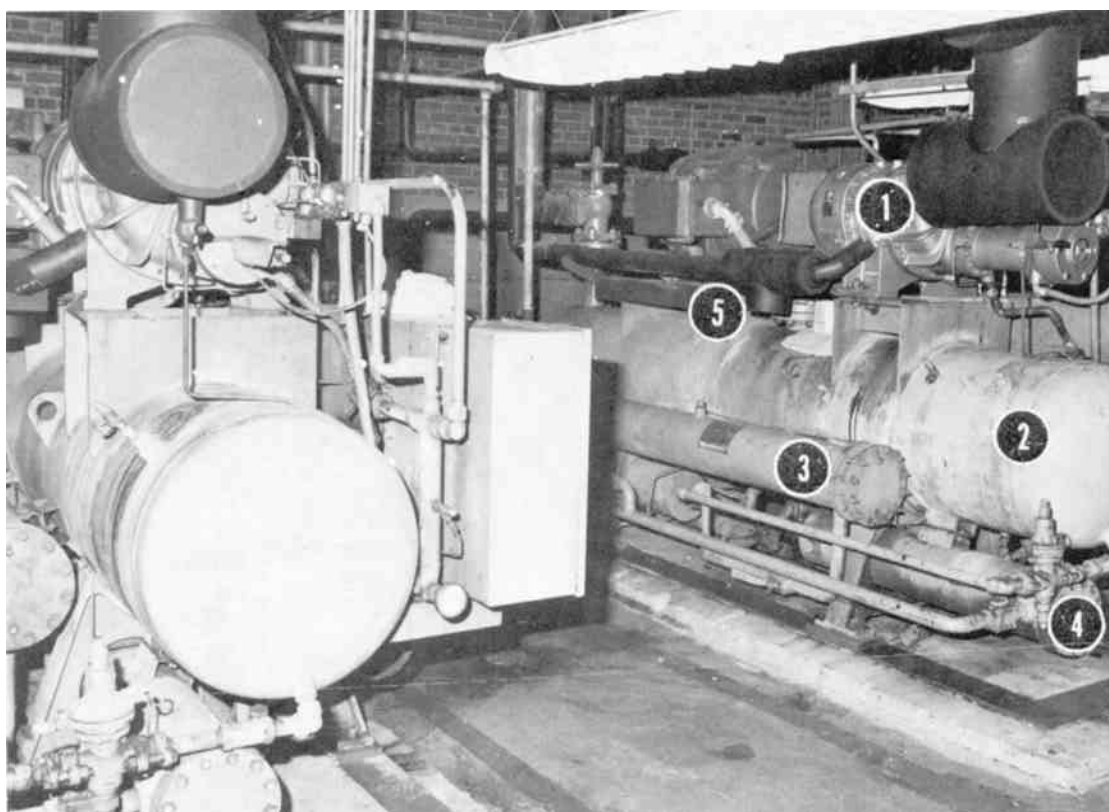

Figure 6-45.—A low-temperature screw or helix compressor system. (1) Compressor; (2) Oil separator and reservoir; (3) Oil collar; (4) Oil filters (5) Hot -gas discharge line.

bond is made until the heat of the copper has been reduced below the temperature of oxidation.

All joints should be silver-soldered and kept to a minimum to reduce leaks. Special copper tube fittings designed for refrigeration service should be used since these are manufactured with close tolerances to assure tight capillary joints in the brazing process.

SAE flare joints are generally not desired, but when necessary, care should be taken in making the joint. The flare must be of uniform thickness and should present a smooth, accurate surface, free from tool marks, splits, or scratches. The tubing must be cut square, provided with a full flare, and any burrs and saw filings removed. The flare seat of the fitting connector must be free from dents or scratches. The flare can best be made with a special swivel head flaring tool, available as a general stores item, which remains stationary and does not tear or scar the face of

the flare in the tubing. Oil should not be used on the face of the flare, either in making up the flare or in securing it to the fitting, since the oil will eventually be dissolved by the refrigerant in the system and cause a leak through the displacement of the oil. The flare joint should always be tightened with two wrenches—one to turn the nut and the other to hold the connecting piece to avoid strain on the connection and cause a leak.

Where pipe or tubing has to be bent, bends should be made with special tools designed for this type of work. Do not use rosin, sand, or any other filler inside the tubing to make a bend. Threaded joints should be coated with a special refrigerant pipe dope. In an emergency, use a thread compound for making up a joint; remember R-12 and R-22 are hydrocarbons, which dissolve any compound containing oil. A compound containing an acid or one whose residual substance forms an acid should not be used. The use of

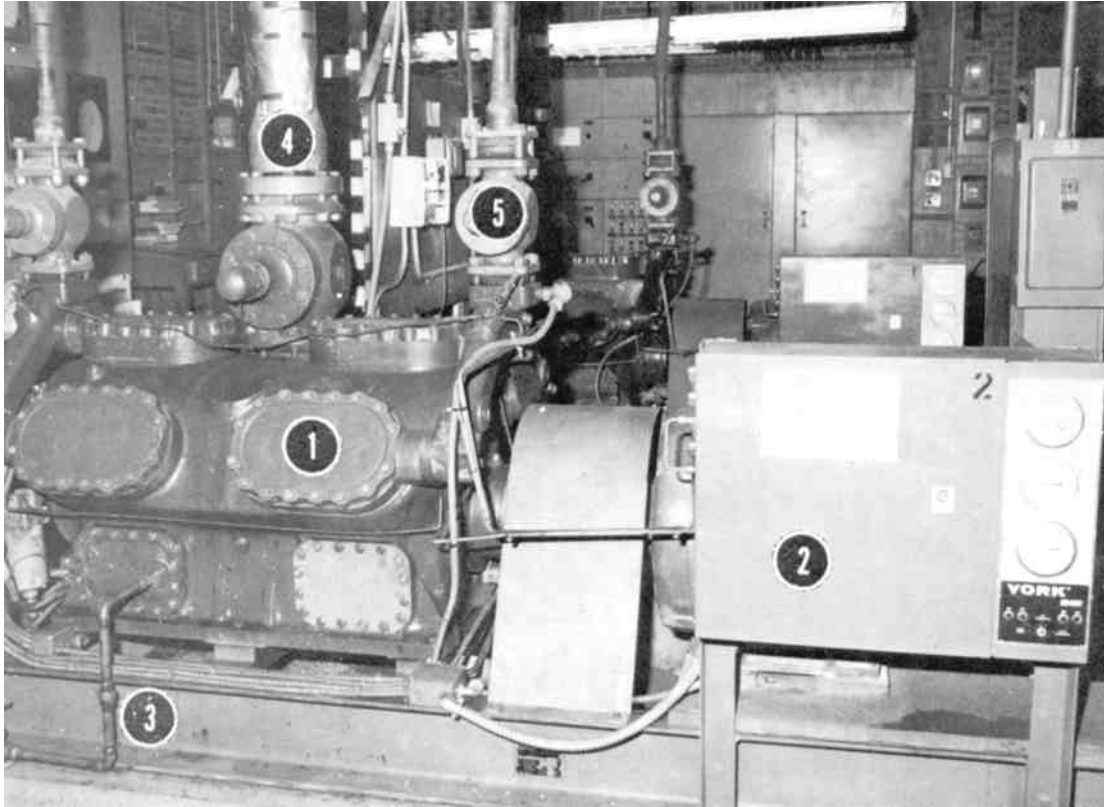

Figure 6-46.—A twelve-cylinder semihermetic reciprocating direct drive compressor. (1) Compressor; (2) control Panel; (3) Oil Return from Reservoir; (4) Suction Line; (5) Hot Gas Discharge Line.

a thick paste made of fresh lethargy and glycerin makes a satisfactory joint compound; however, the joint should be thoroughly cleaned with a solvent to eliminate oil or grease. Thread compounds should be applied to the male part of the thread after it has entered the female coupling one and one-half to two threads to prevent any excess compound from entering the system.

When securing, anchoring, or hanging the suction and liquid lines, be sure and allow enough flexibility between the compressor and the first set of hangers or points where the lines are secured to permit some degree of freedom. This flexibility relieves strain in the joints of these lines at the compressor due to compressor vibration.

MULTIPLE COMPRESSORS

Parallel operation of two or more reciprocating compressors should be avoided unless there are strong and valid reasons for not using a single compressor. In

a situation where two compressors must be used, extreme care in sizing and arranging the piping system is essential.

An acceptable arrangement of two compressors and two condensers is shown in figure 6-47. An equalizer line connects the crankcase at the oil level of each machine. Therefore, the oil in both machines will be at a common level. If machines of different sizes are used, the height of the bases beneath the machines must be adjusted so the normal oil level of both machines is at the same elevation; otherwise, the oil accumulates in the lower machine.

This arrangement is called a single-pipe crankcase equalizer. It can be used only on those machines with a single equalizer tapping entering the crankcase in such a position that the bottom of the tapping just touches the normal oil level.

Another method of piping to maintain proper oil level in two or more compressors uses two equalizer lines between the crankcase—one above the normal oil

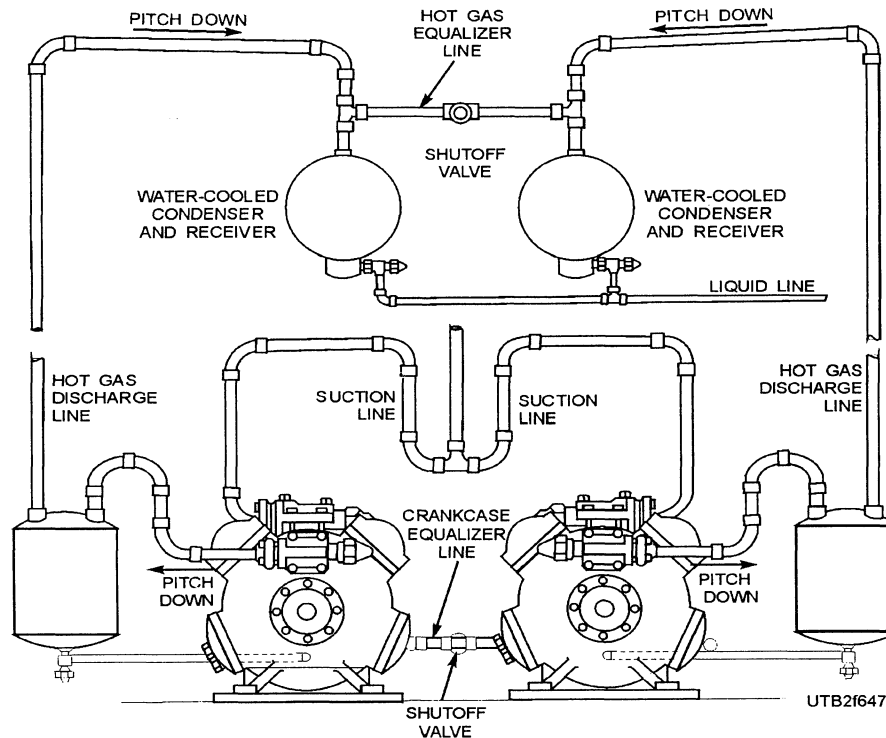

Figure 6-47.—Parallel compressors with separate condensers.

level and one below. The double equalizer system must be used on compressors having two equalizer tappings. A single equalizer line on machines having two equalizer tappings should never be used.

The lower oil equalizer line must not rise above the oil level in the crankcase and should be as level as possible. This is important since the oil builds up in one crankcase if the line rises. The upper equalizer line is a gas line intended to prevent any difference in crankcase pressure that would influence the gravity flow of oil in the lower equalizer line or the level of oil in the crankcase. This upper line must not dip, and care should be taken to eliminate pockets in which oil could accumulate to block the flow of gas. Valves in the crankcase equalizer lines are installed with the stems horizontal, so no false oil levels are created by oil rising over the valve seat and minimize flow resistance.

It is poor practice to skimp on piping when making up these equalizer lines. Oversize piping is preferred to undersize piping. General practice indicates the use of oil equalizer lines equal to the full size of the tapping in the compressor.

The discharge lines from the compressors are also equalized before they enter the condensers. This, in

effect, causes the individual condensers to function as a single unit. This is the most critical point in the piping system. It is here that pressure drop is extremely important—a pressure drop of 0.5 psi being equal to a 1.0 foot head of liquid. Excessive pressure drop in the equalizer line may rob one condenser of all liquid by forcing it into the other condenser. One of the results may be the pumping of large quantities of hot refrigerant vapor into the liquid lines from the condenser of the operating compressor. This could reduce the capacity of the system materially. For this reason, the equalizer line should be just as short and level as possible. A long equalizer line introduces an unequal pressure in condensers if one of the compressors is not operating. The refrigerant then accumulates in the condenser of the nonoperating compressor. The equalizer line should also be generously sized and should be equal to or larger than the discharge 1 in of the largest compressor being used.

If the condensers are more than 10 feet above the compressor, U-traps or oil separators should be installed in the horizontal discharge line where it comes from each compressor.

The traps or separators prevent the oil from draining back to the compressor head on shutdown. Should a single compressor or multiple compressors with capacity modulation be used in an instance of this kind, another solution may be dictated. When a compressor unloads, less refrigerant gas is pumped through the system. The velocity of flow in the refrigerant lines drops off as the flow decreases. It is necessary to maintain gas velocities above some minimum value to keep the entrained oil moving with the refrigerant. The problem becomes particularly acute in refrigerant gas lines when the flow is upward. It does not matter whether the line is on the suction or discharge side of the compressor; the velocity must not be allowed to drop too low under low refrigerant flow conditions. Knowing the minimum velocity, 1,000 feet per minute (fpm), for oil entrainment up a vertical riser and the minimum compressor capacity, the designer of the piping can overcome this problem using a double riser.

The smaller line in the double riser is designed for minimum velocity, at the minimum step, of compressor capacity. The larger line is sized to assure that the velocity in the two lines at full load is approximately the same as in the horizontal flow lines. A trap of minimum dimensions is formed at the bottom of the double-riser assembly, which collects oil at minimum load. Trapped oil then seals off the larger line so the entire flow is through the smaller line.

If an oil separator is used at the bottom of a discharge gas riser, the need for a double riser is eliminated. The oil separator will do as its name implies—separate the major part of the oil from the gas flowing to it and return the oil to the compressor crankcase. Since no oil separator is 100 percent effective, the use of an oil separator in the discharge line does not eliminate the need for double risers in the suction lines of the same system if there are vertical risers in the suction lines. When multiple compressors with individual condensers are used, the liquid lines from the condenser should join the common liquid line at a level well below the bottoms of the condensers. The low liquid line prevents gas from an "empty" condenser from entering the line because of the seal formed by the liquid from other condensers.

NOTE: A common water-regulating valve should control the condenser water supply for a multiple system using individual condensers, so each condenser receives a proportional amount of the condenser water.

Frequently, when multiple compressors are installed, only one condenser is provided. Such

installations are satisfactory only as long as all of the compressors are operating at the same suction pressure. However, several compressors may occasionally be installed which operate at different suction pressures—the pressures corresponding, of course, to the various temperatures needed for the different cooling loads. When this is the case, a separate condenser must be installed for each compressor or group of compressors operating at the same suction pressure. Each compressor, or group of compressors, operating at one suction pressure must have a complete piping system with an evaporator and condenser, separate from the remaining compressors operating at other suction pressures. Separate systems are required because the crankcase of compressors operating at different suction pressures cannot be interconnected. There is no way of equalizing the oil return to such compressors.

The suction connection to a multiple compressor system should be made through a suction manifold, as shown in figure 6-47. The suction manifold should be as short as possible and should be taken off in such a manner that any oil accumulating in the header returns equally to each machine.

Evaporative condensers can be constructed with two or more condensers built into one spray housing. This is accomplished quite simply by providing a separate condensing coil for each compressor, or a group of compressors, operating at the same suction pressure. All of the condensing coils are built into one spray housing; this provides two or more separate condensers in one condenser housing.

- Q28. What type of acid is formed when R-12 is mixed with water?*
- Q29. Air-cooled condensers should be located in areas that provide plenty of clear space around them for what reason?*
- Q30. On close-coupled systems, running refrigerant lines up to the overhead helps eliminate what problem?*
- Q31. To eliminate possible oxidation from occurring while conducting soldering or brazing operations, you should ensure what condition exists within the tube or pipe?*
- Q32. U-traps or oil separators should be installed on multiple compressor systems when the condensers are how many feet above the compressor?*

Q33. If an oil separator is used at the bottom of a discharge riser on multiple compressor applications, the need for a double riser is eliminated. True/False.

MAINTENANCE, SERVICE, AND REPAIR OF REFRIGERATION EQUIPMENT

Learning Objective: Understand different types of maintenance equipment and methods for basic maintenance, service, and repair of refrigeration systems and components.

As a Utilitiesman, you must be able to maintain, service, and repair refrigeration equipment. This phase of our discussion provides information on different jobs that you may be assigned. When information here varies from that in the latest federal or military specifications, the specifications apply. You will find the "Troubleshooting Checklist—Refrigeration Systems," which is presented in table V, appendix II, at the end of this book, helpful in locating and correcting troubles. It is not intended to be all encompassing. Manufacturers also provide instruction manuals to aid you in maintaining and servicing their equipment.

SERVICING EQUIPMENT

Repair and service work on a refrigeration system consists mainly of containing refrigerant and measuring pressures accurately. One piece of equipment is the refrigerant gauge manifold set (fig. 6-48). It consists of a 0-500 psig gauge for measuring pressure at the compressor high side, a compound gauge (0-250 psig and 0 to -30 inches of mercury) to measure the low or suction side, and valves to control admission of the refrigerant to the refrigeration system. It also has the connections and lines required to connect the test set to the system. Depending on test and service requirements, the gauge set can be connected to the low side, the high side, a source of vacuum, or a refrigerant cylinder. A swiveling hanger allows the test set to be hung easily, and the three additional blank connections allow for securing the open ends of the three lines when the gauge set is not in use. There is always a path from the low-side and high-side input to the low-side and high-side gauge (fig. 6-49).

Another important piece of equipment is the portable vacuum pump. The type listed in the Seabee

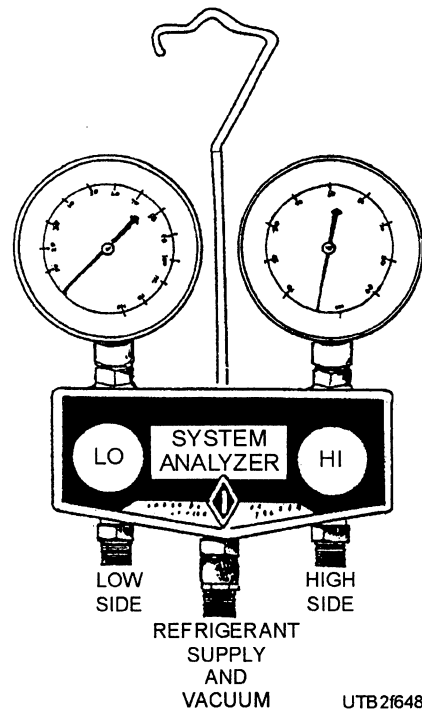

Figure 6-48.—Refrigerant gauge manifold set.

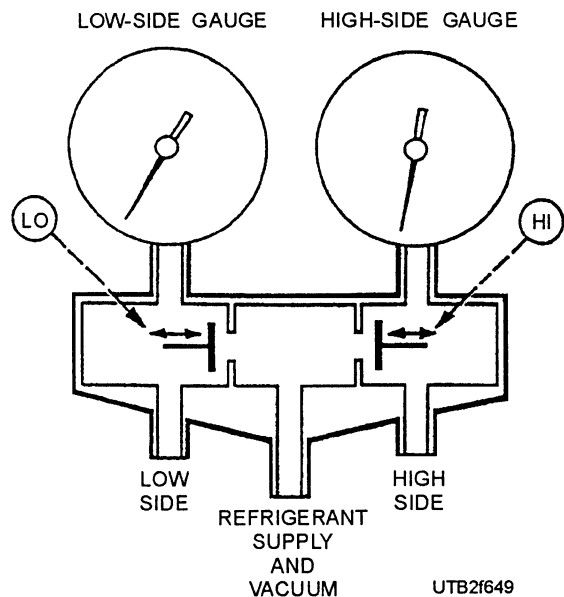

Figure 6-49.—Internal view of a refrigerant gauge manifold set.

Table of Allowance is a sealed unit consisting of a single-piston vacuum pump driven by an electric motor. A vacuum pump is the same as a compressor, except the valves are arranged so the suction valve is opened only when the suction developed by the downward stroke of the piston is greater than the vacuum already in the line. This vacuum pump can develop a vacuum close to -30 inches of mercury, which can be read on the gauge mounted on the unit

(fig. 6-50). The pump is used to reduce the pressure in a refrigeration system to below atmospheric pressure.

Various manufacturers manufacture hermetic refrigeration systems used by the Navy; therefore, the connectors and size of tubing vary. The Table of Allowance provides for a refrigeration service kit that contains several adapters, wrenches, and other materials to help connect different makes of systems to the refrigerant manifold gauge set and the vacuum pump lines. A table affixed to the lid of the storage container identifies the adapter you should use for a particular refrigeration unit.

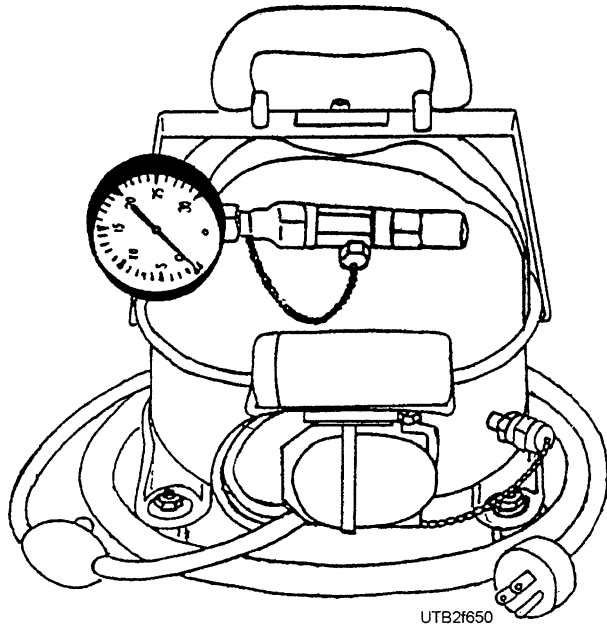

Figure 6-50.—Portable vacuum pump.

TRANSFERRING REFRIGERANTS

Refrigerants are shipped in compressed gas cylinders as a liquid under pressure. Liquids are usually removed from the shipping containers and transferred to a service cylinder (fig. 6-51).

Before attempting transfer of refrigerants from a container to a cylinder, precool the receiving cylinder until its pressure is lower than that of the storage container or cylinder. Precool by placing the cylinder in ice water or a refrigerated tank. You must also weigh the service cylinder, including cap, and compare it with the tare weight stamped or tagged on the cylinder. The amount of refrigerant that may be placed in a cylinder is 85 percent of the tare weight (the weight of a full cylinder and its cap minus the weight of the empty cylinder and its cap).

To transfer refrigerants, connect a flexible charging line on a 1/4-inch copper tube several feet long with a circular loop about 8 to 10 inches in diameter. Be sure to install a 1/4-inch refrigerant shutoff valve (fig. 6-51) in the charging line to the service cylinder. This valve should be inserted so no more than 3 inches of tubing is between the last fitting and the valve itself. This arrangement prevents the loss of refrigerant when the service drum is finally disconnected. The entire line must be cleared of air by leaving the flare nut on the service cylinder loose and cracking the storage cylinder valve. This arrangement allows refrigerant to flow through the tubing, clearing it. After clearing, tighten the flare nut and then open the valve on the service cylinder, the valve on the

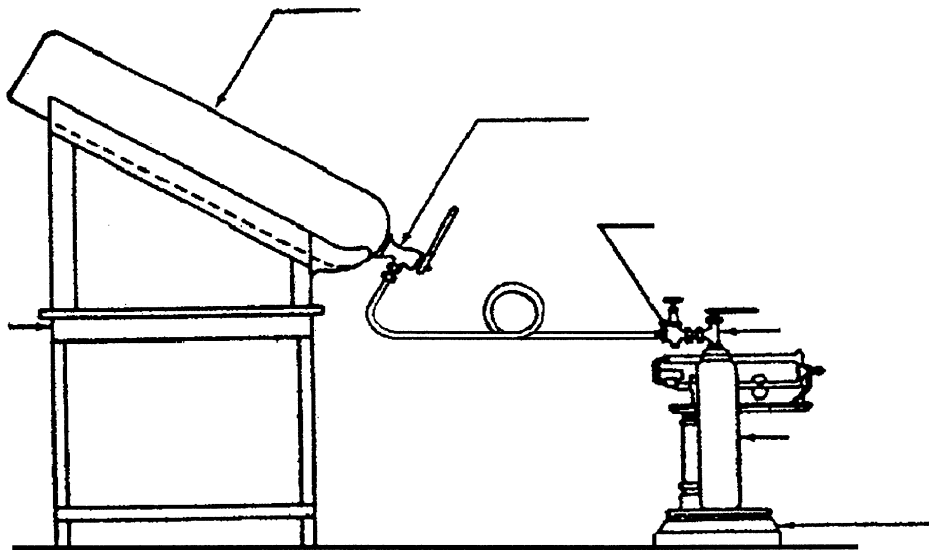

Figure 6-51.—Method of transferring refrigerants to service cylinders.

storage cylinder, and then the 1/4-inch valve in the refrigerant line. When the weight of the service cylinder shows a sufficient amount of refrigerant is in the serviced cylinder, close all valves tightly, and disconnect the charging line at the service cylinder.

CAUTION

To warm refrigerant containers or cylinders for more rapid discharge, use care to prevent a temperature above 120°F because the fusible plugs in the cylinder and valve have a melting point of about 157°F.

EVACUATING AND CHARGING A SYSTEM

One of your duties will be charging a system with refrigerant. If a system develops a leak, you must repair it first, then charge the system. Similarly, if a component of the system becomes faulty and must be replaced, some refrigerant will be lost and the system will require charging.

Evacuation

Before a system can be charged, all moisture and air must be eliminated from the components by drawing a vacuum on the system. To draw a vacuum on the system, proceed as follows:

1. Connect the portable vacuum pump to the vacuum fitting on the refrigerant manifold gauge set (fig. 6-48).
2. Connect the LO line (suction) to the suction service valve of the compressor, using appropriate connectors if required.
3. Turn the suction service valve to mid-position, so vacuum draws from the compressor crankcase and suction line back through the evaporator, expansion valve, and liquid line. When the receiver service valve, condenser service valve, and discharge service valve are open, the pump draws back through the receiver and condenser to the compressor.
4. Attach one end of a 1/4-inch copper tube to the vacuum pump discharge outlet (fig. 6-52). Allow the vacuum pump to draw a vacuum of at least 25 inches. Submerge the other end of the

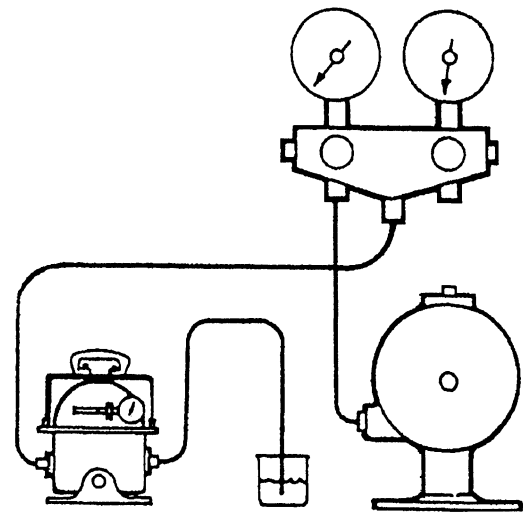

Figure 6-52.—Connections for drawing a vacuum.

copper tubing under 2 or 3 inches of clean compressor oil contained in a bottle.

5. Continue to operate the vacuum pump until there are no more bubbles of air and vapor in the oil, which indicates that a deep vacuum has been obtained.
6. Maintain the deep vacuum operation for at least 5 minutes, and then stop the vacuum pump. Leaking discharge valves of a vacuum pump cause oil to be sucked up into the copper discharge tube. Keep the vacuum pump off at least 15 minutes to allow air to enter the system through any leaks. Then start the vacuum pump. A leaky system causes bubbling of the oil in the bottle.
7. Examine and tighten any suspected joints in the line, including the line to the vacuum pump. Repeat the test.

Charging

In most small refrigerating systems, low-side charging (fig. 6-53) is generally recommended for adding refrigerant after repairs have been made. After the system has been cleaned and tested for leaks, the steps to charge the system are as follows:

1. Connect a line from a refrigerant cylinder to the bottom center connection on the refrigerant gauge manifold set. Be certain the refrigerant cylinder is in a vertical position, so only refrigerant in the form of gas, not liquid, can enter the system. Leave the connection loose and crack the valve on the cylinder. This fills

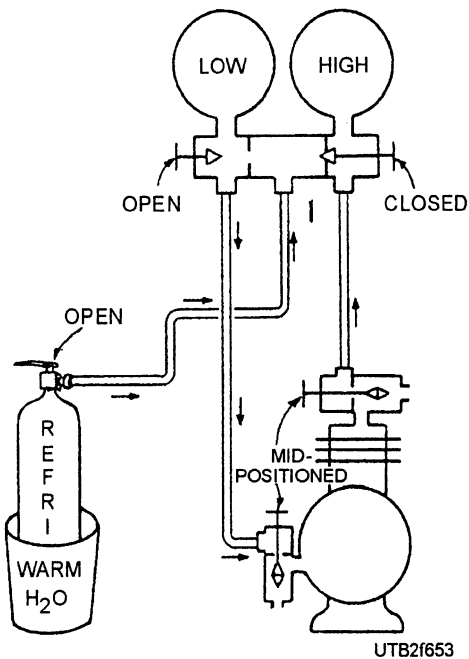

Figure 6-53.—Connections for low-side charging.

the line with gas and clears the air from the line. After clearing, tighten the connection.

2. Connect a line from the LOW (LO) valve (suction) on the gauge manifold set to the suction service valve of the compressor.
3. Start the compressor.
4. Open the valve on the cylinder and the LOW (LO) valve (suction) on the gauge manifold set.
5. Open the suction service valve on the compressor to permit the gas to enter the compressor where it will be compressed and fed to the high side. Add the refrigerant slowly and check the liquid level indicator regularly until the system is fully charged. It is easy to check the receiver refrigerant level in some makes of condensing units because the receiver has minimum and maximum liquid level indicator valves which show the height of the liquid level when opened. If a liquid line sight glass is used, the proper charge may be determined when there is no bubbling of refrigerant as it passes by the glass. The sight glass will appear empty.

Again, be certain the refrigerant cylinder is in the vertical position at all times; otherwise, the liquid refrigerant will enter the compressor and, liquid not being compressible, damage the piston or other parts of the compressor.

REFRIGERANT LEAKS

The best time to test joints and connections in a system is when there is enough pressure to increase the rate at which the refrigerant seeps from the leaking joint. There is usually enough pressure in the high-pressure side of the system; that is, in the condenser, receiver, and liquid line, including dehydrators, strainers, line valves, and solenoid valves. This is not necessarily true of the low-pressure side of the system, especially if it is a low-pressure installation, such as for frozen foods and ice cream, where pressures may run only slightly above zero on the gauge. When there is little pressure, increase the pressure in the low-pressure side of the system by bypassing the discharging pressure from the condenser to the low-pressure side through the service gauge manifold. Small leaks cannot be found unless the pressure inside the system is at least 40 to 50 psi, regardless of the method used to test for leaks.

Halide Leak Detector

The use of a halide leak detector (fig. 6-54) is the most positive method of detecting leaks in a refrigerant system using halogen refrigerants (R-12, R-22, R-11, R-502, etc.). Such a detector consists essentially of a torch burner, a copper reactor plate, and a rubber exploring hose.

Detectors use acetylene gas, alcohol, or propane as a fuel. A pump supplies the pressure for a detector that uses alcohol. If a pump-pressure type of alcohol-burning detector is used, be sure that the air pumped into the fuel tank is

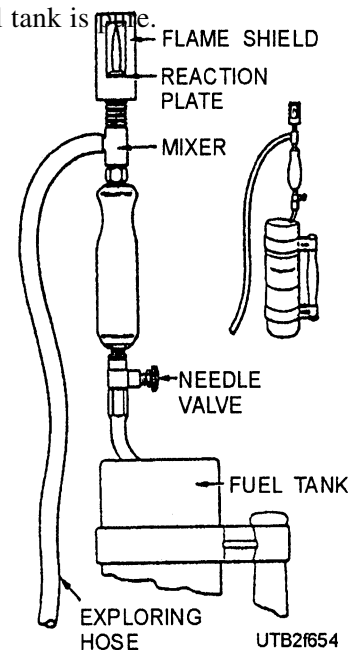

Figure 6-54.—Halide leak detector.

An atmosphere suspected of containing a halogen vapor is drawn through the rubber exploring hose into the torch burner of the detector. Here the air passes over the copper reactor plate, which is heated to incandescence. If there is a minute trace of a halogen refrigerant present, the color of the torch flame changes from blue (neutral) to green as the halogen refrigerant contacts the reactor plate. The shade of green depends upon the amount of halogen refrigerant; a pale green color shows a small concentration and a darker green color, a heavier concentration. Too much of a halogen refrigerant causes the flame to burn with a vivid purple color. Extreme concentrations of a halogen refrigerant may extinguish the flame by crowding out the oxygen available from the air.

Normally, a halide leak detector is used for R-12 and R-22 systems. In testing for leaks always start at the highest point of the system and work towards the lowest point because halogen refrigerants are heavier than air.

When using a leak detector, you will obtain the best results by following the Precautions listed below.

1. Be sure the reactor plate is properly in place.
2. Adjust the flame so it does not extend beyond the end of the burner. (A small flame is more sensitive than a large flame. If it is hard to light the torch when it is adjusted to produce a small flame, block the end of the exploring hose until the fuel ignites; then gradually open the hose.)
3. Clean out the rubber exploring hose if the flame continues to have a white or yellow color. (A white or yellow flame is an indication that the exploring tube is partially blocked with dirt.)
4. Check to see that air is being drawn into the exploring tube; this check can be made from time to time by holding the end of the hose to your ear.
5. Hold the end of the exploring hose close to the joint being tested to prevent dilution of the sample by stray air currents.
6. Move the end of the exploring hose slowly and completely around each joint being tested. (Leak testing cannot be safely hurried. There is a definite time lag between the moment when air enters the exploring hose and the moment it reaches the reactor plate; permit enough time for the sample to reach the reactor plate.)

If a greenish flame is noted, repeat the test in the same area until the source of the refrigerant is located.

Always follow a definite procedure in testing for refrigerant leaks, so none of the joints are missed. Even the smallest leaks are important. However slight a leak may seem, it eventually empties the system of its charge and causes faulty operation. In the long run, the extra time spent in testing each joint will be justified. A refrigerant system should never be recharged until all leaks are discovered and repaired.

Electronic Leak Detector

The most sensitive leak detector of all is the electronic type. The principle of operation is based on the dielectric difference of gases. In operation, the gun is turned on and adjusted in a normal atmosphere. The leak-detecting probe is then passed around the surfaces suspected of leaking. If there is a leak, no matter how tiny, the halogenated refrigerant is drawn into the probe. The leak gun then gives out a piercing sound, or a light flashes, or both, because the new gas changes the resistance in the circuit.

When using an electronic leak detector, minimize drafts by shutting off fans or other devices that cause air movement. Always position the sniffer below the suspected leak. Because refrigerant is heavier than air, it drifts downward. Always remove the plastic tip and clean it before each use. Avoid clogging it with dirt and lint. Move the tip slowly around the suspected leak.

Soap and Water Test

Soap and water may be used to test for leakage of refrigerant with a pressure higher than atmospheric pressure. Make a soap and water solution by mixing a lot of soap with water to a thick consistency. Let it stand until the bubbles have disappeared, and then apply it to the suspected leaking joint with a soft brush. Wait for bubbles to appear under the clear, thick soap solution.

Find extremely small leaks by carefully examining suspected places with a strong light. If necessary, use a mirror to view the rear side of joints or other connections suspected of leaking.

PUMPING DOWN

Quality refrigeration repair includes preventing loss of refrigerant in the system. Whenever a component is removed from the system, the normally

closed system is opened and, unless precautions are taken, refrigerant is lost to the atmosphere. The best way to contain the refrigerant (gas and liquid) is to trap it in the condenser and receiver by pumping down the system.

To pump down the system, proceed as follows:

1. Secure electric power to the unit and connect the refrigerant manifold test set, as shown in figure 6-55.
2. Close the receiver stop (king) valve (by turning the valve stem inwards as far as it will go), and close both gauges on the gauge manifold (LO and HI valves).
3. Start the compressor and mid-seat the discharge and suction service valves.
4. Operate the compressor until the pressure on the suction (LO) gauge on the manifold shows a vacuum at 0 to 1 psi.
5. Stop the compressor. If the pressure rebuilds appreciably, operate the unit again until pressure registers between 0 to 1 psi. Repeat this step until the pressure no longer rebuilds appreciably.
6. When suction pressure remains at about 0 to 1 pound as read on the compound gauge, then front-seat the suction and discharge service

valves (fig. 6-56). This procedure traps practically all the refrigerant in the condenser and receiver.

RECOVERY, RECYCLING, AND RECLAIMING REFRIGERANT

Laws governing the release of chlorofluorocarbon refrigerants (CFCs) into the atmosphere have resulted in the development of procedures to recover, recycle, and reuse these refrigerants. Many companies have developed equipment necessary to prevent the release of CFCs into the atmosphere. Refrigerant recovery management equipment can be divided into three categories—recovery, recycle, and reclaiming equipment.

Recovery

Removing refrigerant from a system in any condition and storing it in an external container is called "recovery." Removal of refrigerant from the system is necessary, in some instances, when repair of a system is needed. To accomplish this, you can use special recovery equipment, which is now a requirement when removing refrigerant from a system. This equipment ensures complete removal of the refrigerant in the system.

Recovery is similar to evacuating a system with the vacuum pump and is accomplished by either the vapor recovery or liquid recovery method. In the vapor

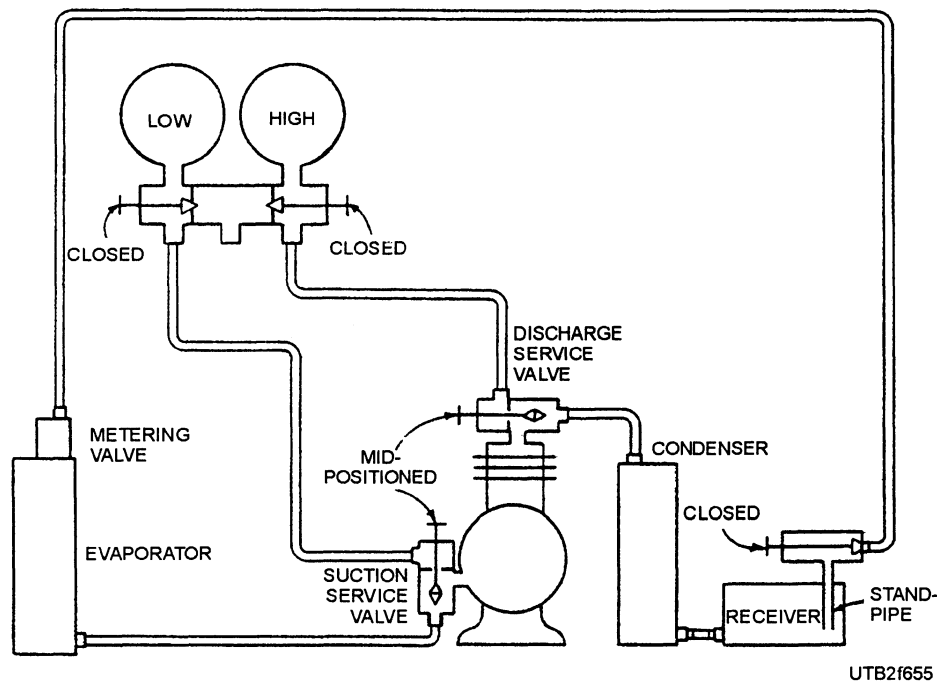

Figure 6-55.—Connections for pumping down a system.

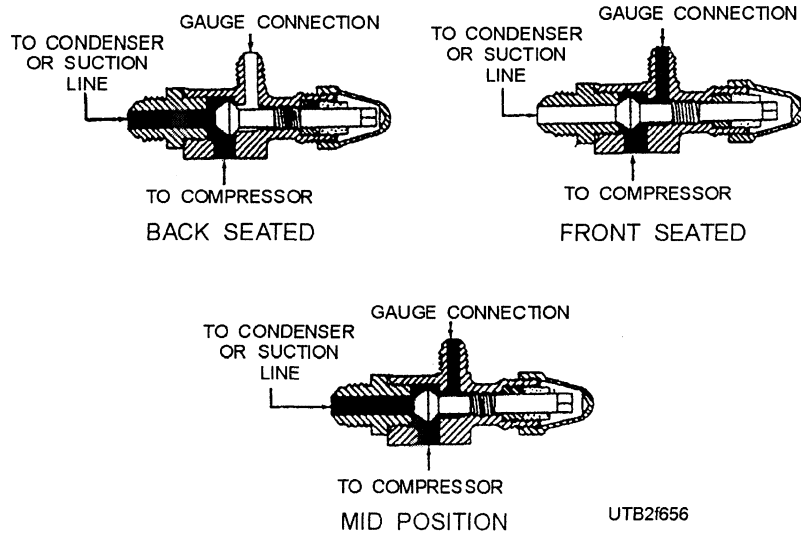

Figure 6-56.—Three-way service valve positions.

recovery method (fig. 6-57), a hose is connected to the low-side access point (compressor suction valve) through a filter-drier to the transfer unit, compressor suction valve. A hose is then connected from the transfer unit, compressor discharge valve to an external storage cylinder. When the transfer unit is turned on, it withdraws vapor refrigerant from the system into the transfer unit compressor, which, in turn, condenses the refrigerant vapor to a liquid and discharges it into the external storage cylinder.

In the liquid recovery method (fig. 6-58), a hose is connected to the low-side access point to the transfer unit compressor discharge valve. A hose is then connected from the transfer unit compressor suction valve through a filter-drier to a two-valve external storage cylinder. A third hose is connected from the

high-side access point (liquid valve at the receiver) to the two-valve external storage cylinder. When the transfer unit is turned on, the transfer unit compressor pumps refrigerant vapor from the external storage cylinder into the refrigeration system, which pressurizes it. The difference in pressure between the system and the external storage cylinder forces the liquid refrigerant from the system into the external cylinder. Once the liquid refrigerant is removed from the system, the remaining vapor refrigerant is removed using the vapor recovery method as previously described.

Most recovery units automatically shut off when the refrigerant has been completely recovered, but check the manufacturer's operational manual for specific instructions. You should make sure that the

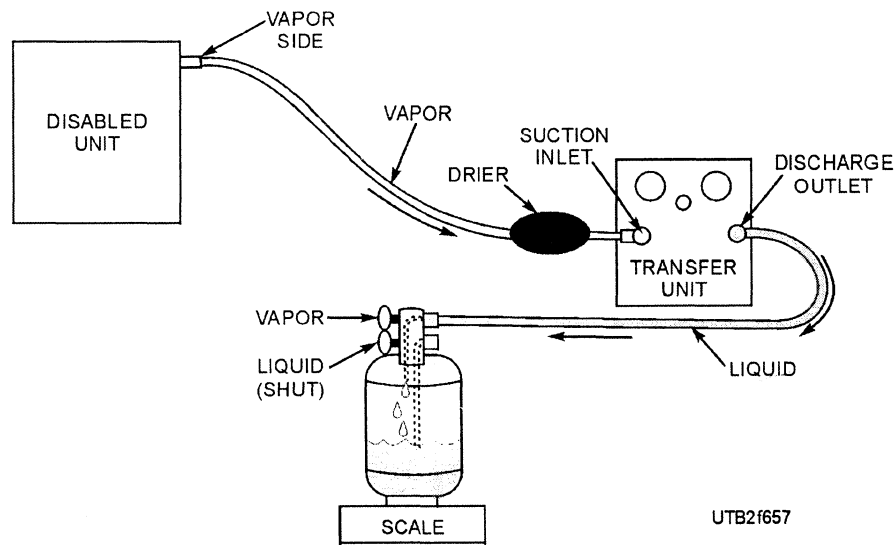

Figure 6-57.—The vapor recovery method.

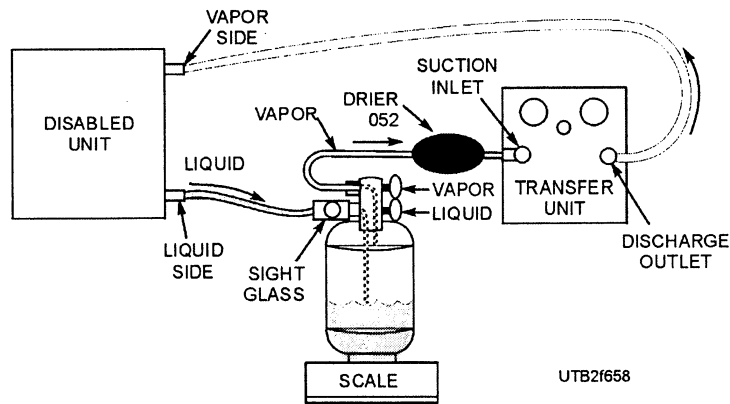

Figure 6-58.—The liquid recovery method.

external storage cylinder is not overfilled. Eighty percent capacity is normal. If the recovery unit is equipped with a sight-glass indicator, any changes that may occur should be noted.

Recycling

The process of cleaning refrigerant for reuse by oil separation and single or multiple passes through filter-driers which reduce moisture, acidity, and matter is called "recycling." In the past, refrigerant was typically vented into the atmosphere. Modern technology has developed equipment to enable reuse of old, damaged, or previously used refrigerant. Refrigerant removed from a system cannot be simply reused—it must be clean. Recycling in the field as

performed by most recycling machines reduces the contaminants through oil separation and filtration. Normally recycling is accomplished during the recovery of the vapor or liquid refrigerant by use of equipment that does both recovery and recycling of refrigerant.

Recycling machines use either the single-pass or multiple-pass method of recycling. The single-pass method (fig. 6-59) processes refrigerant through a filter-drier and/or uses distillation. It makes only one pass through the recycling process to a storage cylinder. The multiple-pass method (fig. 6-60) recirculates refrigerant through the filter-drier many times, and after a period of time or number of cycles, the refrigerant is transferred to a storage cylinder.

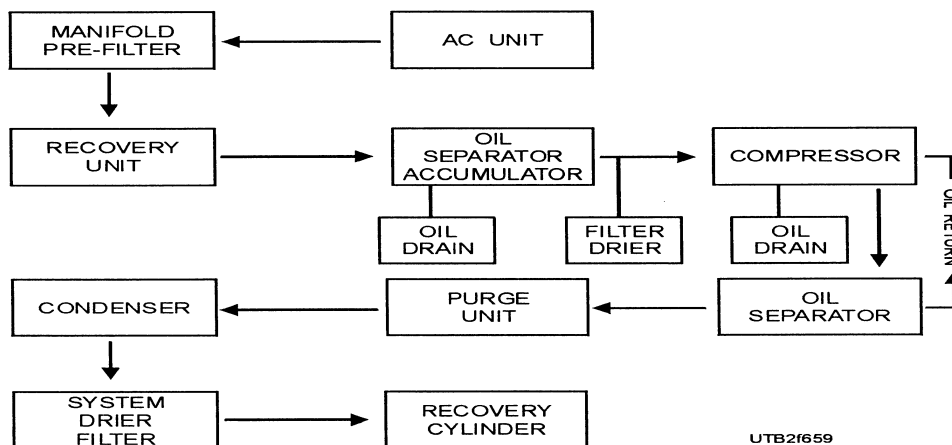

Figure 6-59.—Single-pass method of recycling.

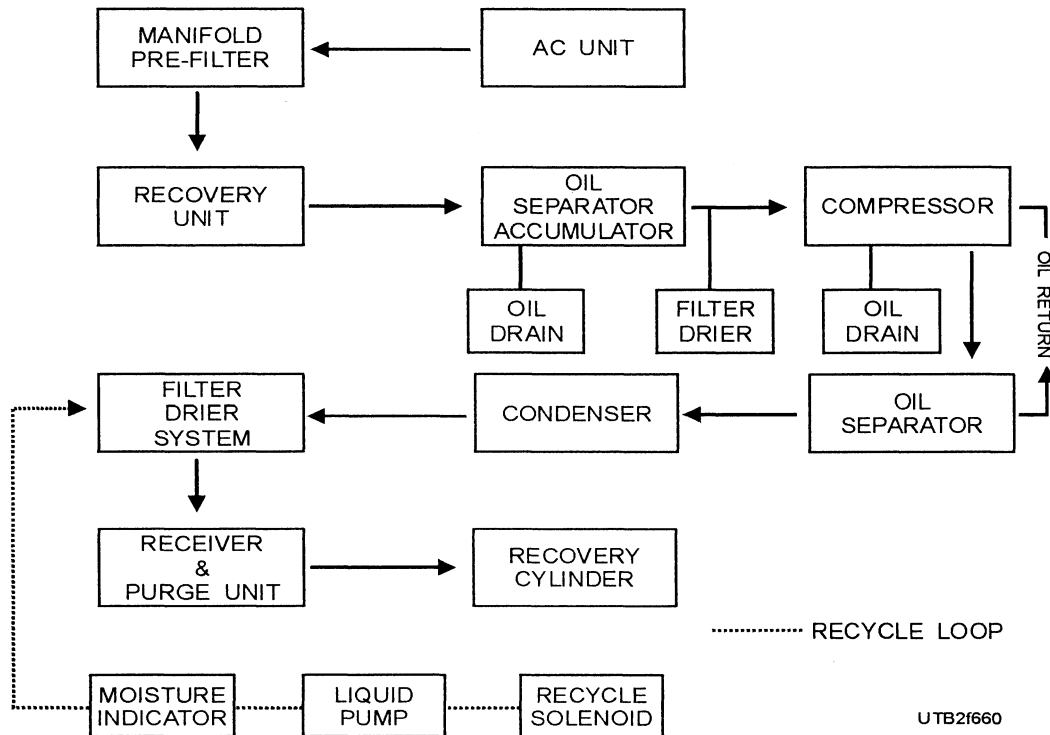

Figure 6-60.—Multiple-pass method of recycling.

Reclaiming

The reprocessing of a refrigerant to original production specifications as verified by chemical analysis is called "reclaiming." Equipment used for this process must meet SAE standards and remove 100 percent of the moisture and oil particles.

Most reclaiming equipment uses the same process cycle for reclaiming refrigerant. The refrigerant enters the unit as a vapor or liquid and is boiled violently at a high temperature at extreme high pressure (distillation). The refrigerant then enters a large, unique separator chamber where the velocity is radically reduced, which allows the high-temperature vapor to rise. During this phase all the contaminants, such as copper chips, carbon, oil, and acid, drop to the bottom of the separator to be removed during the "oil out" operation. The distilled vapor then leaves the separator and enters an air-cooled condenser where it is converted to a liquid. Then the liquid refrigerant passes through a filter-drier into a storage chamber where the refrigerant is cooled to a temperature of 38°F to 40°F by an evaporator assembly.

COMPONENT REMOVAL OR REPLACEMENT

To maintain a refrigerant system at a optimum operating condition sometimes requires removal or replacement of some component. Procedures for removal and replacement of some of the components most often requiring action are covered in this section.

Removing Expansion or Float Valves

To help ensure good results in removing expansion or float valves, you should pump the system down to a suction pressure of just over zero. You should do this at least three times before removing the expansion valve. Plug the opened end of the liquid line and evaporator coil to prevent air from entering the system. Repair or replace the expansion valve and connect it to the liquid valve. Crack the receiver service valve to clear air from the liquid line and the expansion valve. Connect the expansion valve to the evaporator coil inlet and tighten the connection. Pump a vacuum into the low side of the system to remove any air.

Replacing an Evaporator

To replace an evaporator, pump down the system and disconnect the liquid and suction lines. Then remove the expansion valve and the evaporator. Make the necessary repairs or install a new evaporator as required. Replace the expansion valve and connect the liquid and suction lines. Remove moisture and air by evacuating the system. When the evaporator is back in place, pump a deep vacuum as in starting a new installation for the first time. Check for leaks and correct them if they occur. If leaks do occur, be certain to repair them; then pump the system into a deep vacuum. Repeat the process until no more leaks are found.

Removing the Compressor

Using the gauge manifold and a vacuum pump, pump down the system. Most of the refrigerant will be trapped in the condenser and the receiver. To remove the compressor from service, proceed as follows:

1. Once the pump down is complete, the suction valve should already be closed and the suction gauge should read a vacuum. Mid-seat the discharge service valve. Open both manifold valves to allow high-pressure vapor to build up the compressor crankcase pressure to 0 psi.
2. Front-seat (close) the discharge service valve. Then crack the suction service valve until the compound gauge reads 0 to 1 psi to equalize the pressures and then front-seat the valve.
3. Joints should be cleaned with a grease solvent and dried before opening. Unbolt the suction service and discharge service valves from the compressor. DO NOT remove the suction or discharge lines from the compressor service valves.
4. Immediately plug all openings through which refrigerant flows using dry rubber, "cork" stoppers, or tape.
5. Disconnect the bolts that hold the compressor to the base and remove the drive belt or disconnect the drive coupling. You can now remove the compressor.

Removing Hermetic Compressors

Systems using hermetic compressors are not easily repaired, as most of the maintenance performed on them consists of removal and replacement.

1. Disconnect the electrical circuit including the overload switch.
2. Install a gauge manifold. Use a piercing valve (Schraider) if needed.
3. Remove the refrigerant using an EPA approved recovery/recycling unit.
4. Disconnect the suction and discharge lines. Using a pinching tool, pinch the tubing on both the suction and discharge lines, and cut both lines between the compressor and the pinched area.
5. Disconnect the bolts holding the compressor to the base and remove the compressor.

Do not forget to pump down the system and equalize the suction and head pressure to the atmosphere, if applicable. Wear goggles to prevent refrigerant from getting in your eyes. After replacement, the procedures given for removing air and moisture and recharging the system can be followed; however, the procedures may have to be modified because of the lack of some valves and connections. Follow the specific procedures contained in the manufacturer's manual.

- Q34. What are the two major pieces of maintenance equipment used for refrigeration work?*
- Q35. Before attempting transfer of refrigerant from a container to a cylinder, you should precool the receiving cylinder for what reason?*
- Q36. What is the purpose of evacuating a refrigeration system?*
- Q37. You should continue to operate the vacuum pump during evacuation of a system until what condition is obtained?*
- Q38. What method of charging a system is generally recommended?*
- Q39. What are the three methods used to detect refrigerant leaks?*
- Q40. When you pump down a system, where is the refrigerant stored?*

Q41. What are the two methods of refrigerant recovery?

Q42. Recycling refrigerant reduces contaminants through what two processes?

MAINTENANCE OF COMPRESSORS

Learning Objective: Recall the inspection points for open-type compressors and repair procedures for common problems in open-type refrigeration compressors.

Inspection points for open-type compressors and repair procedures for common problems in open-type refrigeration compressors are covered in this section.

OPEN TYPES OF COMPRESSORS

Figure 6-61 shows a vertical single-acting reciprocating compressor. Some of the duties you may perform in maintaining this and other open-type compressors are discussed below.

Shaft Bellows Seal

Refrigerant leakage often occurs at the shaft bellows seal with consequent loss of charge. Install a

test gauge in the line leading from the drum to the compressor. Attach a refrigerant drum to the suction end of the shutoff valve outlet port. Apply the proper amount of pressure, as recommended in the manufacturer's instructions. Test for leaks with a halide leak detector around the compressor shaft, seal gasket, and seal nut. Slowly turn the shaft by hand. When a leak is located at the seal nut, replace the seal plate, gasket, and seal assembly; when the leak is at the gasket, replace the gasket only. Retest the seal after reassembly. (This procedure is typical for most shaft seals on reciprocating open-type compressors.)

Valve Obstructions

Obstructions, such as dirt or corrosion, may be formed under seats of suction or discharge valves. To locate the source of trouble, proceed as follows:

When the suction side is obstructed, the unit tends to run continuously or over long periods. Connect the gauge manifold and start the unit. This pressure gauge (HI) will not indicate an increase in pressure. The low-side gauge (LO) will fluctuate and will not indicate any decrease in pressure. Clean out any obstructions and recheck again by using the test gauge assembly.

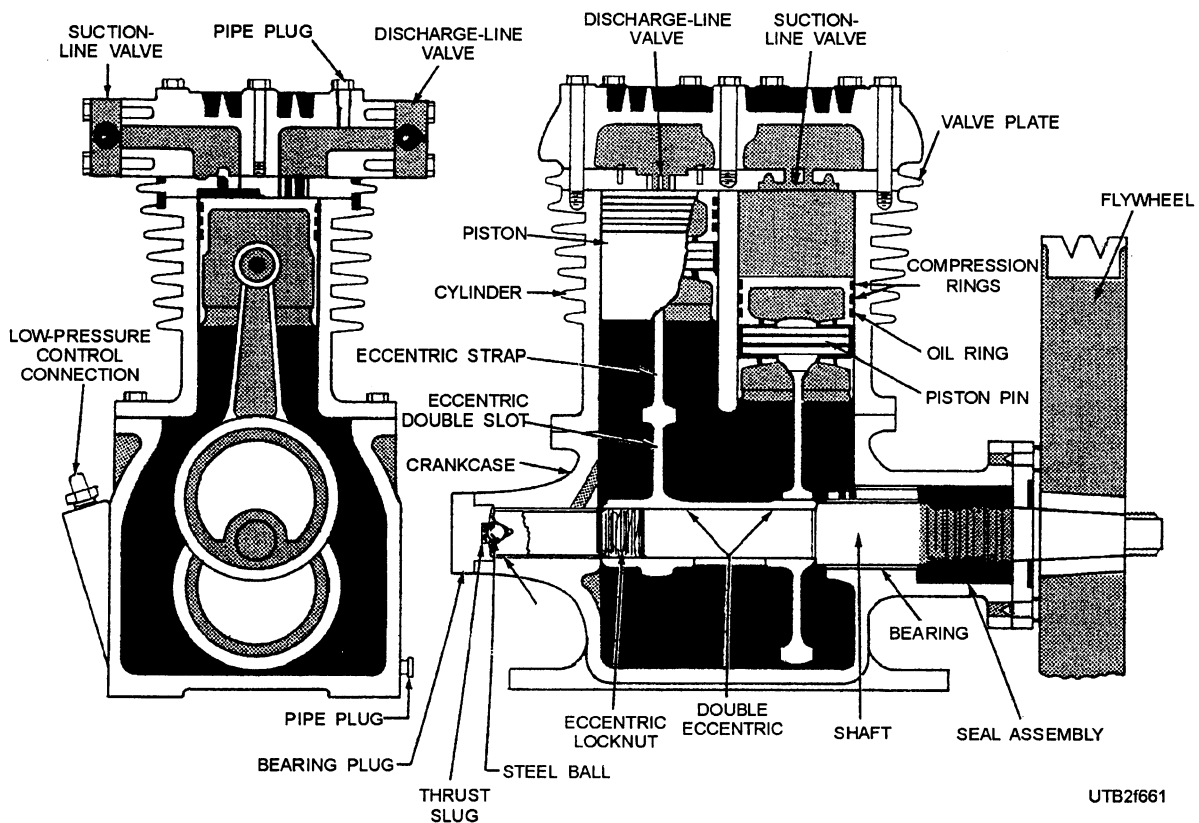

Figure 6-61.—Vertical single-acting reciprocating compressor.

To determine if there is a discharge valve leak, connect the gauge manifold and start the unit. Run it until the low-side (LO) pressure gauge indicates normal pressure for the unit. Stop the unit. With an ear near the compressor housing, listen for a hissing sound. Also, watch the gauges. When leaking caused by an obstruction is present, the low-side pressure rises, and the high side decreases until the pressures are equalized. A quick equalization of pressures indicates a bad leak that should be repaired immediately or the compressor replaced.

Compressor Lubrication

The oil level in the compressor crankcase should be checked by the procedure in the following manufacturer's manual. This procedure normally includes the following steps:

1. Attach the gauge manifold to the suction and discharge service valves.
2. Pump the system down.
3. Close the suction and discharge valves, isolating the compressor.
4. Remove the oil filter plug and measure the oil level as per the manufacturer's manual.

Compressor Knocks

When the compressor knocks, you may have to disassemble the compressor to determine whether the cause is a loose connecting rod, piston pin, or crankshaft. Sometimes a loose piston can be detected without the complete disassembly. In cases requiring disassembly, you should take the following steps:

First, remove the cylinder head and valve plate to expose the top of the piston. Start the motor and press down with your finger on top of the piston. Any looseness can be felt at each stroke. The loose part should be replaced.

Check the oil level because oil levels that are too high often cause knocks. Always make sure that a low oil level is actually the result of a lack of oil, rather than a low charge.

Stuck or Tight Compressor

A stuck or tight compressor often occurs as a result of poor reassembly after a breakdown repair. In such cases, determine where the binding occurs and

reassemble the unit with correct tolerances; avoid uneven tightening of screws or seal covers.

INSPECTION OF COMPRESSORS

An inspection should be performed on a refrigeration unit from time to time for knocks, thumps, rattles, and so on, while the unit is in operation. When any of the external parts have excessive grease, dirt, or lint, they should be cleaned. Before cleaning, you should always ensure the power is off.

A careful check of the entire system with instruments or tools is essential to determine if there has been any loss of refrigerant. **NO LEAK IS TOO SMALL TO BE FIXED.** Each leak must be stopped immediately.

Some specific conditions to look for during the inspection of a refrigeration system are as follows:

Inadequate lubrication of bearings and other moving parts.

Rusty or corroded parts discovered during the inspection should be cleaned and painted.

Hissing sounds at the expansion valve, low readings on the discharge pressure gauge, and bubbles in the receiver sight glass, all indicate a weak refrigerant charge.

Loose connections and worn or pitted switch contacts result in inoperative equipment or reduced reliability. Thermostats with burned contacts may produce abnormal temperatures in the cooled compartment.

Fans difficult to rotate by hand, with bent blades, or loose or worn belts are a source of trouble easy to locate and correct during inspection.

Air filters clogged with dirt should be cleaned or replaced during the inspection.

Hermetically sealed units should be inspected for signs of leaks and high temperatures and for too much noise or vibration.

Q43. On compressors, refrigerant leaks most often occur at what location?

Q44. Hissing sounds at the expansion valves, low discharge pressure, and bubbles in the receiver sight glass during inspections indicate what possible problems?

Q45. When inspecting hermetic compressors, you should look for what type of problems?

MAINTENANCE OF MOTORS

Learning Objective: Understand basic maintenance of motors and methods of electrical troubleshooting of motors.

Troubles with the electrical motors used to drive the compressors of mechanical refrigeration systems fall into two classes—mechanical and electrical.

MECHANICAL PROBLEMS

Some compressors are belt-driven from the electrical motor. For proper operation, both the belt tension and pulley alignment adjustments must be made. Belt tension should be adjusted so a 1-pound force on the center of the belt, either up or down, does not depress it more than one-half inch. To adjust the alignment, loosen the setscrew on the motor pulley after tension adjustment is made. Be sure the pulley turns freely on the shaft; add a little oil if necessary. Turn the flywheel forward and backward several times. When it is correctly aligned, the pulley does not move inward or outward on the motor shaft. Tighten the setscrew holding the pulley to the shaft before starting the motor.

Compressors may also be driven directly by a mechanical coupling between the motor and compressor shafts. Be sure the two shafts are positioned so they form a straight line with each other. The coupling on direct drive units should be realigned after repair or replacement. Clamp a dial indicator to the motor half coupling with its pointer against the outer edge of the compressor half coupling. Rotate the motor shaft, and observe any fluctuations of the indicator. Move the motor or compressor until the indicator is stationary when revolving the shaft one full turn. Secure the hold-down bolts and then recheck.

Moisture in the System

When liquid refrigerant that contains moisture vaporizes, the moisture separates from the vapor. Because the vaporization of the refrigerant causes a cooling effect, the water that has separated can freeze. Most of the expansion and vaporization of the refrigerant occurs in the evaporator. However, a small amount of the liquid refrigerant vaporizes in the expansion valve, and the valve is cooled below the

freezing point of water. As a result, ice can form in the expansion valve and interfere with its operation. If the needle in the valve freezes in a slightly off-seat position, the valve cannot permit the passage of enough refrigerant. If the needle freezes in a position far from the seat, the valve feeds too much refrigerant. In either case, precautions must be observed to assure a moisture-free system.

A dehydrator is filled with a chemical known as a desiccant, which absorbs moisture from the refrigerant passing through the dehydrator. Dehydrators are installed in the liquid line to absorb moisture in the system after the original installation. An arrow on the dehydrator indicates the direction of flow. Desiccants are granular and are composed of silica gel, activated alumina, or calcium sulfate. Do not use calcium chloride or chemicals that form a nonfreezing solution. These solutions may react with moisture to form undesirable substances, such as gums, sludges, or waxes. Follow the manufacturer's instructions as to limitations of dehydrators, as well as operation, recharging, replacing, and servicing.

Loose Copper Tubing

In sealed units, loose copper tubing is usually detected by the sound of rattling or metallic vibration. Bending the tubing carefully to the position of least vibration usually eliminates the defect. Do not touch it against other tubing or parts at a point of free movement, and do not change the tubing pitch or the tubing diameter by careless bending.

In open units, lengths of tubing must be well supported by conduit straps or other devices attached to walls, ceilings, or fixtures. Use friction tape pads to protect the copper tubing from the metal of the strap. When two tubes are together in a parallel position, wrapping and binding them together with tape can prevent vibration. When two lines are placed in contact for heat exchange, they should be soldered to prevent rattling and to permit better heat transfer.

Doors and Hardware

When hinges must be replaced because of lack of lubrication or other reasons, the use of exact duplicates is preferable. Loose hinge pins must be securely braided. When thrust bearings are provided, they are held in place by a pin.

The latch or catch is usually adjusted for proper gasket compression. Shims or spacers may be added

or removed for adjustment. Latch mechanisms should be lubricated and adjusted for easy operation. Latch rollers must not bind when operated. Be sure to provide sufficient clearance between the body of the latch and catch, so no contact is made. The only contact is made between the catch and the latch bolt or roller. These instructions also apply to safety door latches, when they are provided for opening the door from the inside, although it is locked from the outside. Warping of the door usually causes lack of complete gasket contact between the door overlap and the doorframe. Correct the condition by installing a long, tapered wooden shim or splicer rigidly in place under the door seal. If this does not tighten the door to the frame, remove the door and either reline or rebuild it.

Repair or replace missing, worn, warped, or loose door gaskets. If the gasket is tacked on, rustproof tacks or staples should be used. If the gasket is clamped or held in place by the doorframe or the door panel, an exact replacement is necessary. In either case, the gasket should be installed so when the door is closed a complete and uniformly tight seal results. If doors freeze closed due to condensation and subsequent freezing, apply a light coat of glycerine on the gaskets.

Defrosting

Cooling units in the 35°F to 45°F reach-in or walk-in refrigerators or cold storage rooms are generally defrosted automatically by setting the low-pressure control switch to a predetermined level. If this setting causes overload with consequent heavy frosting of the coil, manual defrosting is necessary. Cooling units of 35°F and lower temperatures are defrosted manually. The most common method for manual defrosting is to spray water over the cooling

coil, although warm air, electric heating, or hot gas refrigerant defrosts too. In any case, the fans must not be in operation during the defrosting. Defrost plate-type evaporator banks in below-freezing refrigerators when the ice has built up to a thickness of one-half inch or when the temperature of the fixtures or the suction pressure is affected by the buildup of ice. Before removing frost from the plates, place a tarpaulin on the floor or over the contents of the refrigerator to catch the frost under the bank.

ELECTRICAL DEFECTS

The control systems for modern refrigeration systems are composed of many components that use or pass electrical power, including compressor drive motors, pressure switches, thermostats, and solenoid stop valves. Although as a Utilitiesman second class you are not responsible for troubleshooting these electrical components, you must be able to use the multimeter for locating opens, shorts, and grounds, and measuring voltage and current. Module 3 of the Navy Electricity and Electronics Training Series, NAVEDTRA 172-03-00-93 (*Introduction to Circuit Protection, Control, and Measurement*), will help you in learning to use electrical meters and testing equipment. When you have finished studying the module, return to this chapter and learn how to locate opens, shorts, and grounds in refrigeration control circuits.

Opens

Figure 6-62 shows a simple refrigeration control system. You have learned the basics of electricity and how to use meters. Using this figure, you will put that knowledge to work. Remember one fact—if you are

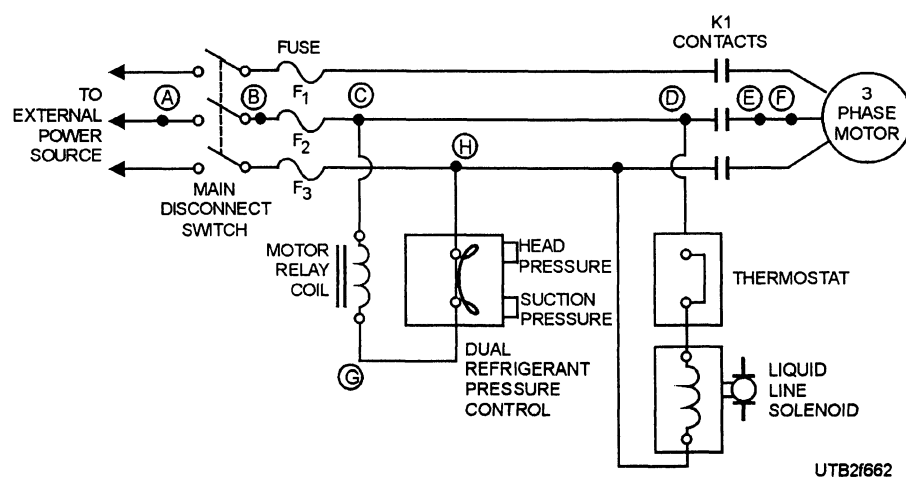

Figure 6-62.—Simple refrigeration control system.

not sure what you are doing, call your supervisor or arrange for a Construction Electrician to assist you.

An "open" is defined as the condition of a component that prevents it from passing current. It may be a broken wire, a burned or pitted relay contact, a blown fuse, a broken relay coil, or a burned-out coil winding. An open can be located in one of two ways. For the components in series, such as the main disconnect switch, fuses, the wire from Point C to Point D (fig. 6-62), the relay contacts, and the wire from Point E to Point F, a voltmeter should be used. Set up the voltmeter to measure the source voltage (120 volts ac, in this case). If the suspected component is open, the source will be measured across it. To check part of the main disconnect switch, close the switch and measure from Point A to Point B. If the meter reading is 0 volts, that part of the switch is good; if the voltage equals the source voltage, the switch is open. To check the fuse F2, measure across it, Point B to Point C. Measuring across Points C and D or E and F will check the connecting wires for opens. One set of relay contacts can be checked by taking meter readings at Points D and E. These are just a few examples, but the rule of series components can always be applied. Remember, the three sets of contacts of relay K1 will not close unless voltage is present across the relay coil; the coil cannot be open or shorted. When testing an electrical circuit, follow the safe practices you have been taught and use procedures outlined in equipment manuals.

Opens in components that are in parallel cannot easily be found with a voltmeter because, as you know, parallel components have voltage across them at all times when the circuit is energized. In figure 6-62, the branch with the motor relay K1 and the dual refrigerant pressure control are considered a parallel circuit. Because when the main disconnect switch is closed and the fuses are good, there is voltage between Points C and H, regardless of whether the relay coil and pressure switch are open. To check for opens in these components, use an ohmmeter set at a low range. Disconnect all power by opening (and locking out, if possible) the main disconnect switch. This action removes all power and ensures both personal and equipment safety. To check the motor relay K1 to see if its coil is open, put the ohmmeter leads on Points C and G. A reading near infinity (extremely high resistance) indicates an open. The contacts of the dual refrigerant pressure control can be tested by putting the ohmmeter leads from Point G to Point H. Again, a reading near infinity indicates open contacts. You may need to consult the manufacturer's manual for the

physical location of Points G and H. Notice the contacts of the control are normally closed when neither the head pressure nor the suction pressure is above its set limits.

Shorts

Shorts are just the opposite of opens. Instead of preventing the flow of current, they allow too much current to flow, often blowing fuses. The ohmmeter on its lowest range is used to locate shorts by measuring the resistance across suspected components. If the coil of the motor relay K1 is suspected of being shorted, put the leads on Points C and G. A lower than normal reading (usually almost zero) indicates a short. You may have to determine the normal reading by consulting the manufacturer's manual or by measuring the resistance of the coil of a known good relay. If fuses F2 and F3 blow and you suspect a short between the middle and bottom lines (fig. 6-62), put the ohmmeter leads between Points C and H. Again, a low reading indicates a short. Remember, in all operations using an ohmmeter, it is imperative that all power be removed from the circuit for equipment and personal safety. Don't fail to do this!

Grounds

A ground is an accidental connection between a part of an electrical circuit and ground, due perhaps, to physical contact through wearing of insulation or movement. To locate a ground, follow the same procedure you used to locate a short. The earth itself, a cold-water pipe, or the frame of a machine are all examples of ground points. To see whether a component is shorted to ground, put one ohmmeter lead on ground and the other on the point suspected to be grounded and follow the rules for locating a short. Be sure to turn off all power to the unit. It may even be wise to check for the presence of voltage first. Use a voltmeter set to the range suitable for measuring source voltage. If power does not exist, then use the ohmmeter.

The limited amount of instruction presented here is not enough to qualify you as an electrician, but it should enable you to find such troubles as blown fuses, poor electrical connections, and the like. If the trouble appears more complicated than this, call your supervisor or ask for assistance from a Construction Electrician.

Testing the Motor

As a Utilitiesman, you should be able to make voltage measurements in a refrigeration system to ensure the proper voltage is applied to the drive motor, as shown on the rating plate of the motor. If the proper voltage is applied (within 10 percent) to the terminals of the motor and yet it does not run, you must decide what to do. If it is an open system (not hermetically sealed), it is the Construction Electrician's job to repair the motor. If it is a hermetically sealed unit, however, you must use special test equipment to complete further tests and perhaps make the unit operational again.

If the unit doesn't run, it may be because the motor rotor or compressor crankshaft is stuck (remember, in a hermetically sealed unit, they are one and the same). If you apply electrical power to try and move the motor in the correct direction first and then reverse the power, you may be able to rock it free and not have to replace the unit. This is one of the purposes of the hermetic unit analyzer (fig. 6-63). To rock the rotor of an hermetically sealed unit, follow these steps:

1. Determine from the manufacturer's manual whether the motor is a split-phase or a capacitor-start type.
2. Remove any external wiring from the motor terminals.

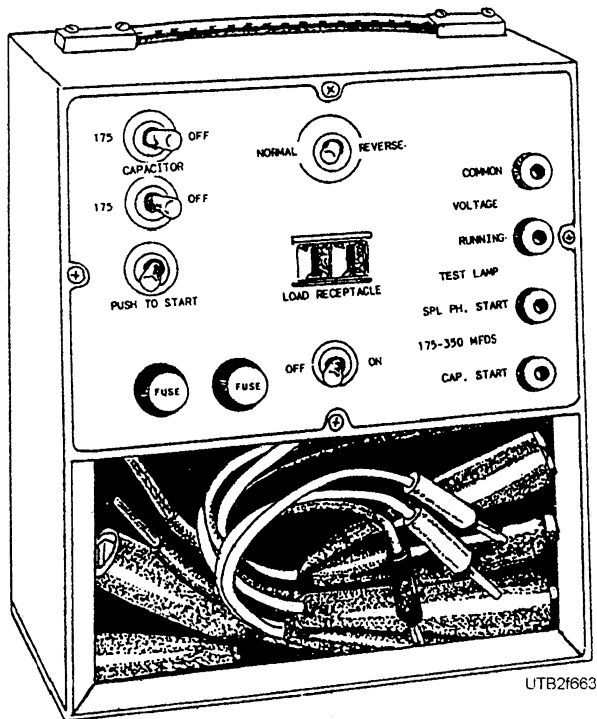

Figure 6-63.—Hermetic unit analyzer.

3. Place the analyzer plugs in the jacks of the same color. If a split-phase motor is used, put the red plug in jack No. 3; if the capacitor-start motor is used, put the red plug in jack No. 4; and select a capacity value close to the old one with the toggle switches.
4. Connect the test clips as follows:
 - White to common
 - Black to the running winding
 - Red to the starting winding
5. Hold the push-to-start button down and at the same time move the handle of the rocker switch from normal to reverse. The frequency of rocking should not exceed five times within a 15-second period. If the motor starts, be certain that the rocker switch is in the normal position before releasing the push-to-start button.
6. More tests can be made with the hermetic unit analyzer, such as testing for continuity of windings and for grounded windings. Procedures for these tests are provided in the manual that comes with the analyzer. Generally, if the rocking procedure does not result in a free and running motor, the unit must be replaced.

TROUBLESHOOTING REFRIGERATION EQUIPMENT

Troubleshooting of any type of refrigeration unit depends, in part, on your ability to compare normal operation with that obtained from the unit being operated. Obviously for you to detect these abnormal operations, you must first know what normal operation is. Climate affects running time. A refrigeration unit generally operates more efficiently in a dry climate. In an ambient temperature of 75°F, the running period usually approximates 2 to 4 minutes, and the off period, 12 to 20 minutes.

It is beyond the scope of this text to cover all of the troubles you may encounter in working with refrigeration equipment. If you apply yourself, you can acquire a lot of additional information through on-the-job training and experience and studying the manufacturer's instruction manuals.

First and foremost, safety must be stressed and safe operating practices followed before and while doing any troubleshooting or service work. All local and

national codes, as well as DoD rules concerning safety, must be observed. Some of the more important safety steps that are often overlooked are as follows:

- Protective equipment, such as eye protection, gloves, hard hats, and so forth, must be available and worn.
- Fire extinguishers must be readily available, in good working order, and adequate for the situation.
- Safety tags with such notations as "Danger," "Hands Off," "Do Not Operate," and "Do Not Throw Switch" should be attached to valves, switches, and at other strategic locations when servicing or making repairs.
- Install machinery guards properly before operating machinery.

The above is only a short list and not intended to be all-inclusive. You will also find table W, appendix II, "Troubleshooting — Industrial Refrigeration," and table Y, appendix II, "Troubleshooting — Domestic Refrigerators and Freezers," useful guides for locating and correcting different troubles in refrigeration equipment.

- Q46. Most problems with electrical motors for refrigeration system compressors fall into what classes?*
- Q47. How often is the coupling on the shafts of direct drive motors realigned?*
- Q48. What piece of equipment is installed in a refrigeration system just before the expansion valve to remove moisture?*
- Q49. Manually defrosting is normally required on refrigeration units that operate at what temperature?*
- Q50. If you suspect a component is open, you should test the source in what way?*
- Q51. What unit of measurement on a multimeter do you use to test for a short?*
- Q52. When checking for a ground, you use the same troubleshooting procedure as used for what other problem?*
- Q53. Troubleshooting a refrigeration system depends partly on your knowledge of how the equipment runs normally. True/False.*

LOGS

Learning Objective: Understand the importance and use of maintaining, operating, and inspecting logs for refrigeration equipment.

When maintaining, standing watch, operating, or inspecting refrigerating and air-conditioning equipment, the Utilitiesman may be responsible for keeping operation, inspection, or maintenance logs on the equipment. Try to keep the logs neat and clean. You must ensure that any information recorded in them is accurate and legible.

Operation and maintenance logs may help to spot trouble in the equipment. They also aid in ensuring proper periodic maintenance and inspection are performed on the equipment. Logs may provide a means of self-protection when trouble occurs and the cause can be placed on an individual.

Good judgment must always be used in analysis of service troubles and specific corrections should be followed whenever possible. One of the methods for determining when and what corrective measures are necessary on equipment or a plant which is not operating properly is to compare the pressures and temperatures of various parts of the system with corresponding readings taken in the past when the equipment or plant was operating properly under similar heat load and circulating water temperature conditions.

A typical operating log may contain entries such as the following:

- Date and time of readings
- Ambient temperature
- Suction pressure and temperature readings
- Discharge pressure and temperature readings
- Condenser pressure and temperature
- Evaporator pressure and temperature
- Oil level in the compressor
- Operating hours

These types of readings give a complete picture of the current and past operating conditions of the equipment or plant and can assist the Utilitiesman in keeping the equipment or plant at its maximum efficiency.

Maintenance logs contain entries of when, what, and who performed routine periodic maintenance on

the equipment or plant. Such logs help ensure that the equipment or plant is well maintained and that the life expectancy of the equipment or plant is fully used. These logs also can assist in determining estimates for future budget requirements for maintenance on the equipment or plant. Maintenance log entries may include the following:

- Date of maintenance
- Type of maintenance
- What was done
- Who did the work

- Cost of the work
- Materials used

It is important to compare operating log readings of the equipment or plant before the maintenance with those taken after the maintenance was completed to ensure maintenance was accomplished properly, and that it had no ill effects on the equipment or plant.

Q54. Operating and maintenance logs can assist in spotting troubles in refrigeration equipment or plants. True/False.

Q55. Maintenance logs can be used to figure future maintenance cost requirements. True /False.

CHAPTER 7

AIR CONDITIONING

Learning Objectives: Understand the principles of air conditioning and the operation of basic air-conditioning systems. Recognize the characteristics and procedures required to install, operate, and maintain air-conditioning systems

Air conditioning is the simultaneous control of temperature, humidity, air movement, and the quality of air in a conditioned space or building. The intended use of the conditioned space is the determining factor for maintaining the temperature, humidity, air movement, and quality of air. Air conditioning is able to provide widely varying atmospheric conditions ranging from conditions necessary for drying telephone cables to that necessary for cotton spinning. Air conditioning can maintain any atmospheric condition regardless of variations in outdoor weather.

This chapter explains the following subjects as they pertain to air conditioning: principles of air conditioning, heat pumps, chilled-water systems, periodic maintenance, cooling towers, troubleshooting, automotive air conditioning, and ductwork.

PRINCIPLES OF AIR CONDITIONING

Learning Objective: Understand the basic principles of temperature, humidity, and air motion in relation to air conditioning.

Air conditioning is the process of conditioning the air in a space to maintain a predetermined temperature-humidity relationship to meet comfort or technical requirements. This warming and cooling of the air is usually referred to as winter and summer air conditioning.

Here, you are introduced to the operating principles of air-conditioning systems, the environmental factors controlled by air conditioning, and their effects on health and comfort. Refrigerative air conditioners and general procedures pertaining to the installation, operation, and maintenance of these systems are examined. Also, the operation and maintenance of the controls used with these systems are explained.

TEMPERATURE

Temperature, humidity, and air motion are interrelated in their effects on health and comfort. The term given to the net effects of these factors is effective *temperature*. This effective temperature cannot be measured with a single instrument; therefore, a psychrometric chart aids in calculating the effective temperature when given sufficient known conditions relating to air temperatures and velocity.

Research has shown that most persons are comfortable in air where the effective temperature lies within a narrow range. The range of effective temperatures within which most people feel comfortable is called the COMFORT ZONE. Since winter and summer weather conditions are markedly different, the summer zone varies from the winter zone. The specific effective temperature within the zone at which most people feel comfortable is called the COMFORT LINE (fig. 7-1).

HUMIDITY

Air at a high temperature and saturated with moisture makes us feel uncomfortable. However, with the same temperature and the air fairly dry, we may feel quite comfortable. Dry air, as it passes over the surface of the skin, evaporates the moisture sooner than damp air and, consequently, produces greater cooling effect. However, air may be so dry that it causes us discomfort. Air that is too dry causes the surface of the skin to become dry and irritates the membranes of the respiratory tract.

HUMIDITY is the amount of water vapor in a given volume of air. RELATIVE HUMIDITY is the amount of water vapor in a given amount of air in comparison with the amount of water vapor the air would hold at a temperature if it were saturated. Relative humidity may be remembered as a fraction or percentage of water vapor in the air; that is, DOES HOLD divided by CAN HOLD.

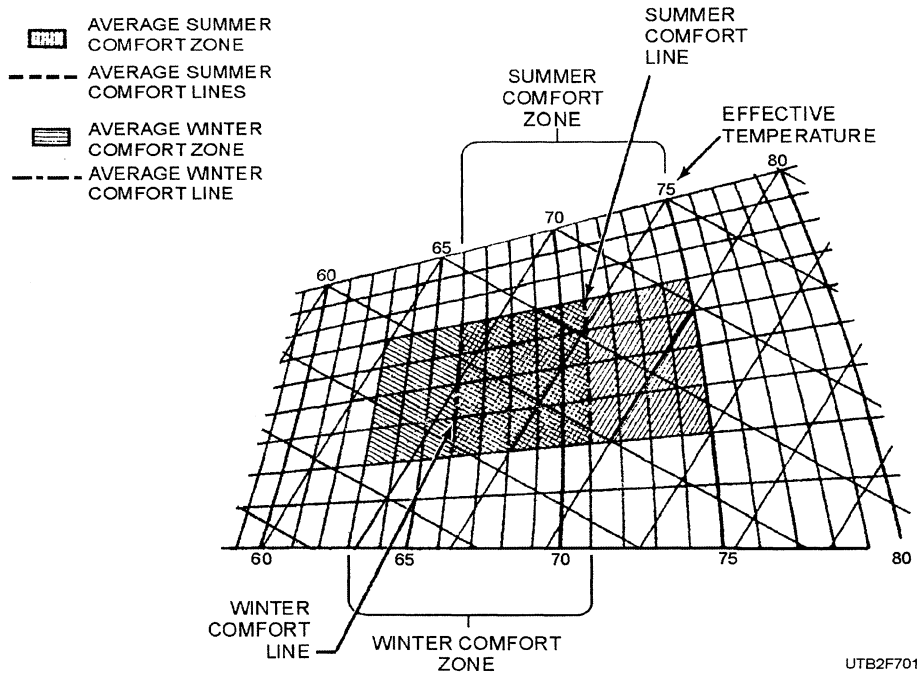

Figure 7-1.—Comfort zones and lines.

Relative humidity is determined by using a sling psychrometer. It consists of a wet-bulb thermometer and a dry-bulb thermometer, as shown in figure 7-2. The wet-bulb thermometer is an ordinary thermometer similar to the dry-bulb thermometer, except that the bulb is enclosed in a wick that is wet with distilled water. The wet bulb is cooled as the moisture evaporates from it while it is being spun through the air. This action causes the wet-bulb thermometer to register a lower temperature than the dry-bulb thermometer. Tables and charts have been designed that use these two temperatures to arrive at a relative humidity for certain conditions.

A comfort zone chart is shown in figure 7-3. The comfort zone is the range of effective temperatures

within which the majority of adults feel comfortable. In looking over the chart, note that the comfort zone represents a considerable area. The charts show the wet- and dry-bulb temperature combinations that are comfortable to the majority of adults. The summer comfort zone extends from 66°F effective temperature to 75°F effective temperature for 98 percent of all personnel. The winter comfort zone extends from 63°F effective temperature to 71°F effective temperature for 97 percent of all personnel.

Dew-Point Temperature

The dew point depends on the amount of water vapor in the air. If the air at a certain temperature is not

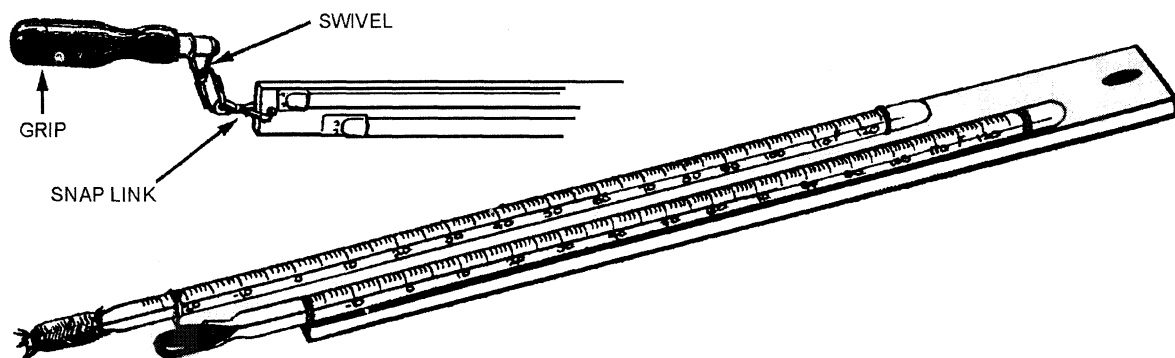

Figure 7-2.—A standard sling psychrometer.

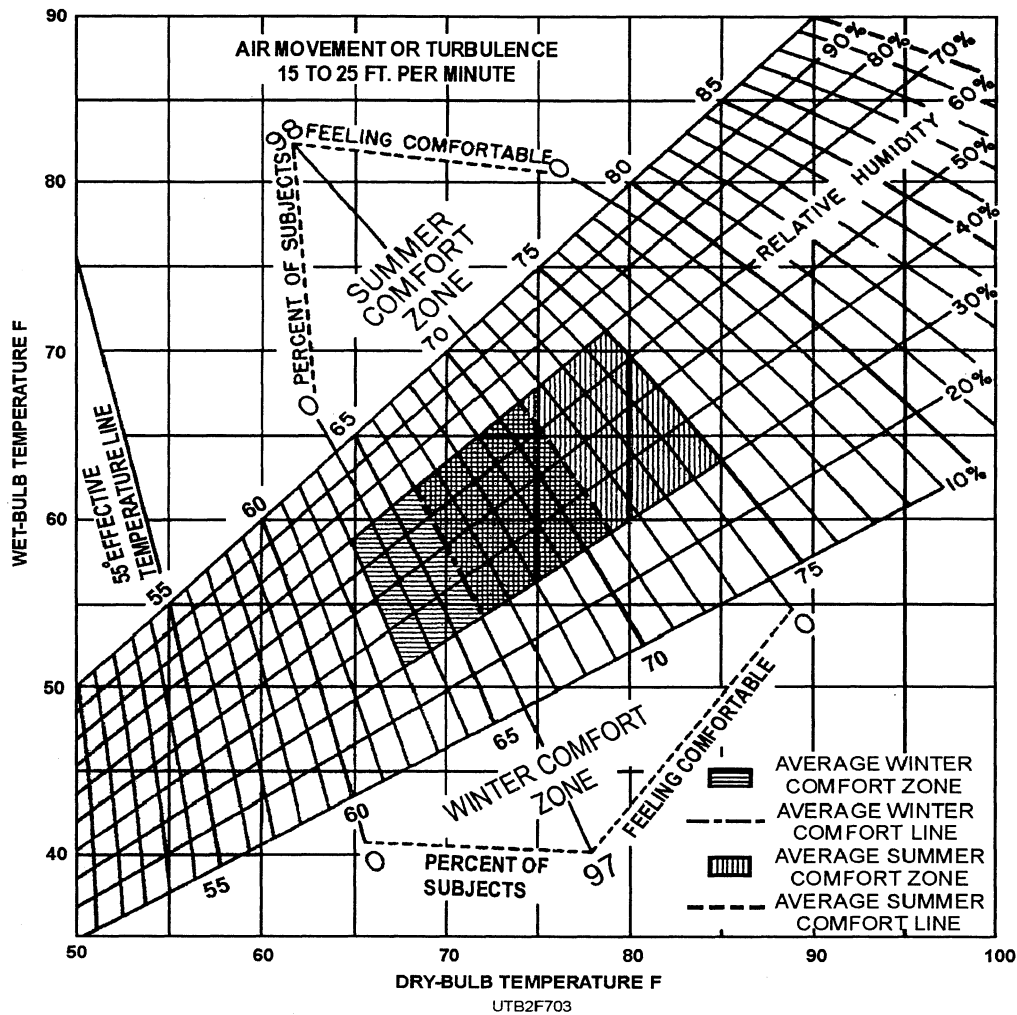

Figure 7-3.—Comfort zone chart.

saturated (maximum water vapor at that temperature) and the temperature of that air falls, a point is finally reached at which the air is saturated for the new and lower temperature, and condensation of the moisture begins. This is the dew-point temperature of the air for the quantity of water vapor present.

Relationship of Wet-Bulb, Dry-Bulb, and Dew-Point Temperatures

A definite relationship exists between the wet-bulb, dry-bulb, and dew-point temperatures. These relationships are as follows:

- When the air is not saturated but contains some moisture, the dew-point temperature is lower than the dry-bulb temperature, and the wet-bulb temperature is in between.

- As the amount of moisture in the air increases, the amount of evaporation (and, therefore, cooling) decreases. The difference between the temperatures becomes less.
- When the air becomes saturated, all three temperatures are the same and the relative humidity is 100 percent.

To HUMIDIFY air is to increase its water vapor content. To DEHUMIDIFY air is to decrease its water vapor content. The device used to add moisture to the air is a humidifier, and the device used to remove the moisture from the air is a dehumidifier. The control device, sensitive to various degrees of humidity, is called a HUMIDISTAT.

Methods for humidifying air in air-conditioning units usually consist of an arrangement that causes air to pick up moisture. One arrangement consists of a

heated water surface over which conditioned air passes and picks up a certain amount of water vapor by evaporation, depending upon the degree of humidifying required. A second arrangement to humidify air is to spray or wash the air as it passes through the air-conditioning unit.

During the heat of the day, the air usually absorbs moisture. As the air cools at night, it may reach the dew point and give up moisture, which is deposited on objects. This principle is used in dehumidifying air by mechanical means.

Dehumidifying equipment for air conditioning usually consists of cooling coils within the air conditioner. As warm, humid air passes over the cooling coils, its temperature drops below the dew point and some of its moisture condenses into water on the surface of the coils. The condensing moisture gives up latent heat that creates a part of the cooling load that must be overcome by the air-conditioning unit. For this reason, the relative humidity of the air entering the air conditioner has a definite bearing on the total cooling load. The amount of water vapor that can be removed from the air depends upon the air over the coils and the temperature of the coils.

PURITY OF AIR

The air should be free from all foreign materials, such as ordinary dust, rust, animal and vegetable matter, pollen, carbon (soot) from poor combustion, fumes, smoke, and gases. These types of pollution are harmful to the human body alone; however, they include an additional danger because they also carry bacteria and harmful germs. So, the outside air brought into a space or the recirculating air within a space should be filtered during air conditioning.

Air in an air conditioner may be purified or cleaned by filters, air washing, or electricity.

Filters may be designed as permanent or throwaway types. They are usually made of fibrous material, which collects the particles of dust and other foreign matter from the air as it passes through the filter. In some cases, the fibers are dry, while in others they have a viscous (sticky) coating. Filters usually have a large dust-holding capacity. When filters become dust-laden, they are either discarded or cleaned. Permanent filters are usually cleaned. Throwaway filters are only one-time filters and are discarded when they become dust-laden.

Often water sprays are used to recondition the air by washing and cleaning it. These sprays may also serve to humidify or dehumidify the air to some extent.

In some large air-conditioning systems, air is cleaned by electricity. In this type of system, electrical precipitators remove the dust particles from the air. The air is first passed between plates where the dust particles are charged with electricity; then the air is passed through a second set of oppositely charged plates that attract and remove the dust particles (fig. 7-4). This method is by far the best method of air cleaning, but the most expensive.

CIRCULATION OF AIR

The velocity of the air is the primary factor that determines what temperature and humidity are required to produce comfort. (The chart in figure 7-3 is based on an air movement of 15 to 25 feet per minute.) We know from experience that a high velocity of air produces a cooling effect on human beings. However, air velocity does not produce a cooling effect on a surface that does not have exposed moisture. A fan does not cool the air, but merely increases its velocity. The increased velocity of air passing over the skin surfaces evaporates moisture at a greater rate; thereby, cooling the individual. For this reason, circulation of air has a decided influence on comfort conditions. Air can be circulated by gravity or mechanical means.

When air is circulated by gravity, the cold, and therefore heavier, air tends to settle to the floor, forcing the warm and lighter air to the ceiling. When the air at the ceiling is cooled by some sort of refrigeration, it will settle to the floor and cause the warm air to rise. The circulation of the air by this method will eventually stop when the temperature of the air at the ceiling is the same as the temperature on the floor.

Air may be circulated by mechanical means by axial or radial fans. When either the axial or radial fan is mounted in an enclosure, it is often called a blower.

- Q1. What is the term given to the net effects of temperature, humidity, and air motion?*
- Q2. The comfort line is the specific effective temperature at which most people feel comfortable. True /False*
- Q3. What is the term for the amount of water vapor in a given volume of air?*
- Q4. What instrument is used to measure relative humidity?*

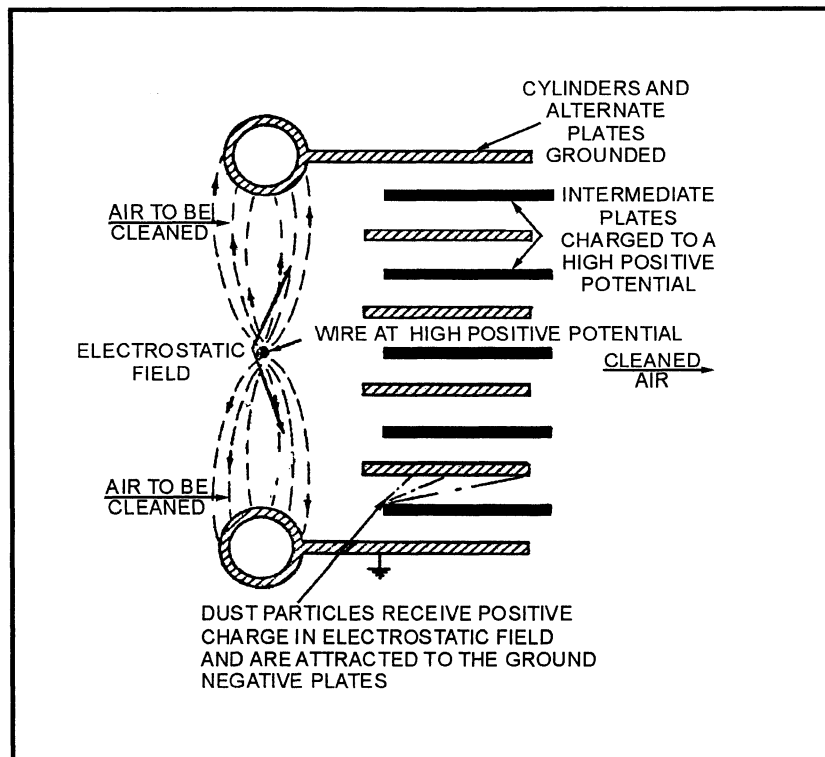

UTB2F704

Figure 7-4.—Diagram of an electrostatic filter.

- Q5. *The point where water vapor condenses is called the dew point. True /False*
- Q6. *What condition exists when the dry-bulb, wet-bulb, and dew-point temperatures are the same?*
- Q7. *What are the two types of filter designs?*
- Q8. *What is the primary factor that determines the temperature and humidity required for room comfort?*

AIR-CONDITIONING SYSTEMS

Learning Objective: Recognize basic types of air-conditioning systems, and understand the operation, maintenance, and repair methods and procedures.

A complete air-conditioning system includes a means of refrigeration, one or more heat transfer units, air filters, a means of air distribution, an arrangement for piping the refrigerant and heating medium, and controls to regulate the proper capacity of these components. In addition, the application and design requirements that an air-conditioning system must meet make it necessary to arrange some of these components to condition the air in a certain sequence.

For example, an installation that requires re-heating of the conditioned air must be arranged with the re-heating coil on the downstream side of the dehumidifying coil; otherwise, re-heating of the cooled and dehumidified air is impossible.

There has been a tendency by many designers to classify an air-conditioning system by referring to one of its components. For example, the air-conditioning system in a building may include a dual duct arrangement to distribute the conditioned air; therefore, it is then referred to as a dual duct system. This classification makes no reference to the type of refrigeration, the piping arrangement, or the type of controls.

For the purpose of classification, the following definitions are used:

- An air-conditioning unit is understood to consist of a heat transfer surface for heating and cooling, a fan for air circulation, and a means of cleaning the air, motor, drive, and casing.
- A self-contained air-conditioning unit is understood to be an air-conditioning unit that is complete with compressor, condenser, evaporator, controls, and casing.

- An air-handling unit consists of a fan, heat transfer surface, and casing.
- A remote air-handling unit or a remote air-conditioning unit is a unit located outside of the conditioned space that it serves.

SELF-CONTAINED AIR-CONDITIONING UNITS

Self-contained air-conditioning units may be divided into two types: window-mounted and floor-mounted units. Window-mounted air-conditioning units usually range from 4,000 to 36,000 Btu per hour in capacity (fig. 7-5). The use of windows to install these units is not a necessity. They may be installed in transoms or directly in the outside walls (commonly called a "through-the-wall" installation). A package type of room air conditioner, showing airflow patterns for cooling, ventilating, and exhausting services, is shown in figure 7-6.

In construction and operating principles, the window unit is a small and simplified version of much larger systems. As shown in figures 7-7 and 7-8, the basic refrigeration components are present in the window unit. The outside air cools the condenser coils. The room air is circulated by a fan that blows across the evaporator coils. Moisture, condensed from the humid air by these coils, is collected in a pan at the bottom of the unit; it is usually drained to the back of the unit and discharged. Most window units are equipped with thermostats that maintain a fixed dry-bulb temperature and moisture content in an area within reasonable limits. These units are installed so there is a slight tilt of the unit towards the outside, toward the condenser, to assist in drainage of the condensate. It is a good idea to mount the unit on the eastside of the building to take advantage of the afternoon shade. These units require very little mechanical attention before they are put into operation. Window units are normally operated by the user who should be properly instructed on their use.

Floor-mounted air-conditioning units range in size from 24,000 to 360,000 Btu per hour and are also

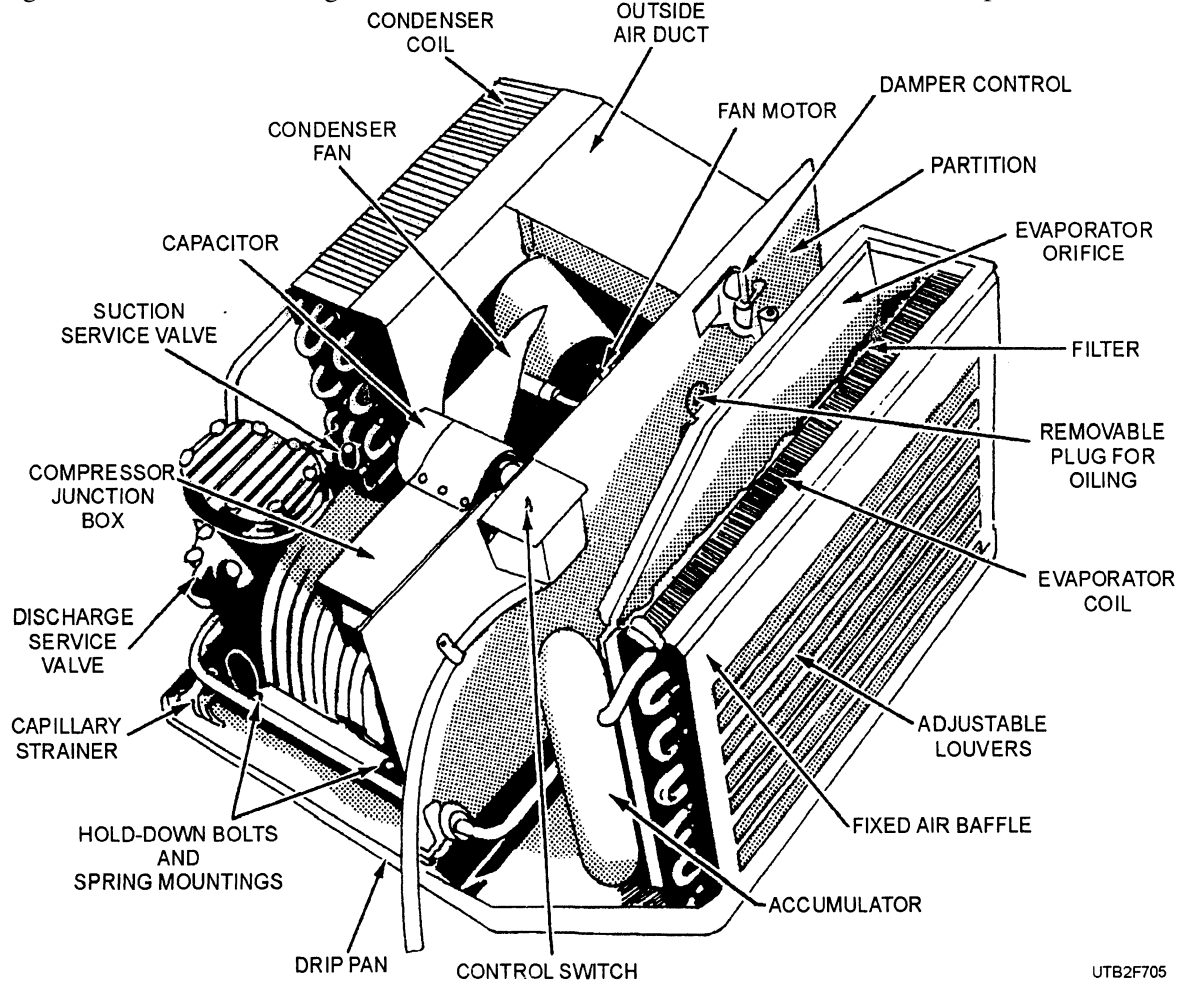

UTB2F705

Figure 7-5.—Window air conditioner.

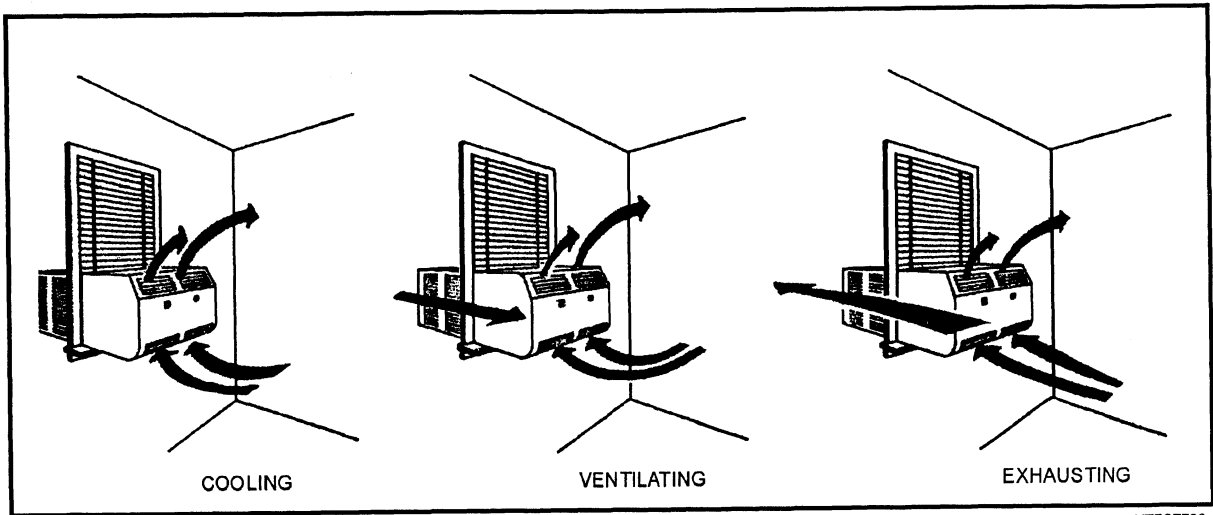

UTB2F706

Figure 7-6.—Package type of air-conditioning unit showing airflow patterns.

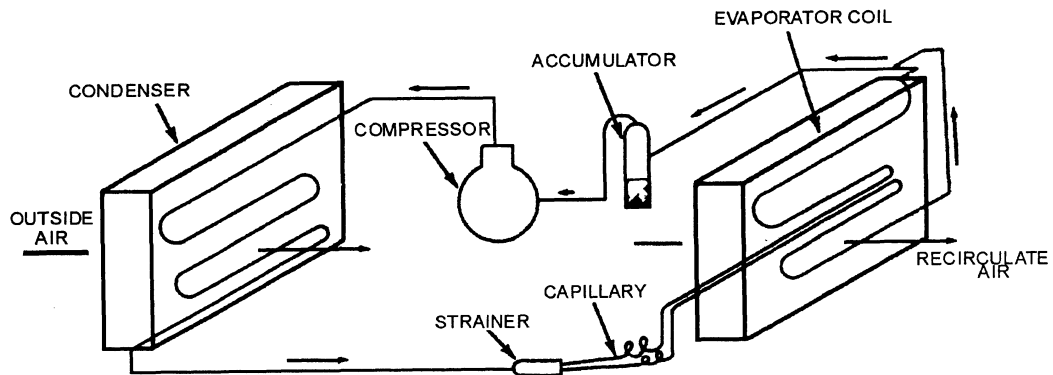

UTB2F707

Figure 7-7.—A refrigerant cycle of a package air conditioner.

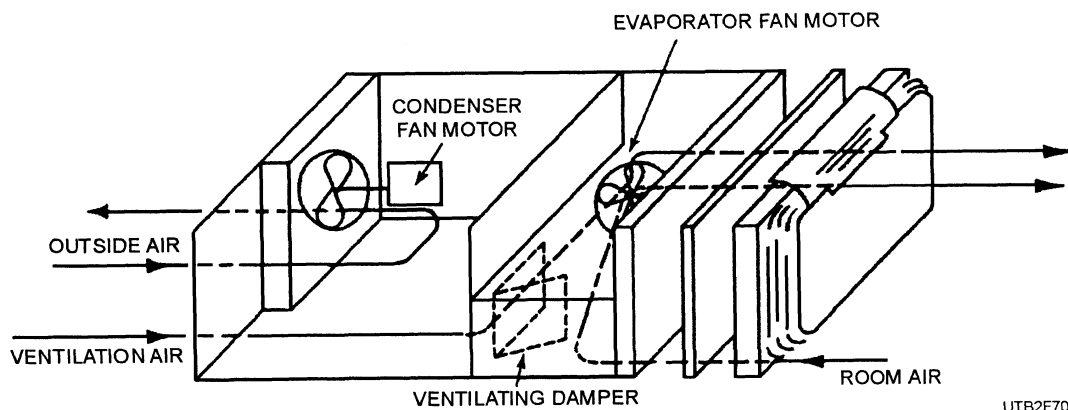

UTB2F708

Figure 7-8.—Air-handling components of a package type of room air conditioner.

referred to as PACKAGE units, as the entire system is located in the conditioned space. These larger units, like window units, contain the complete system of refrigeration components. A self-contained unit with panels removed is shown in figure 7-9. These units

normally use either a water-cooled or air-cooled condenser.

Self-contained units should be checked regularly to ensure they operate properly. Filters should be

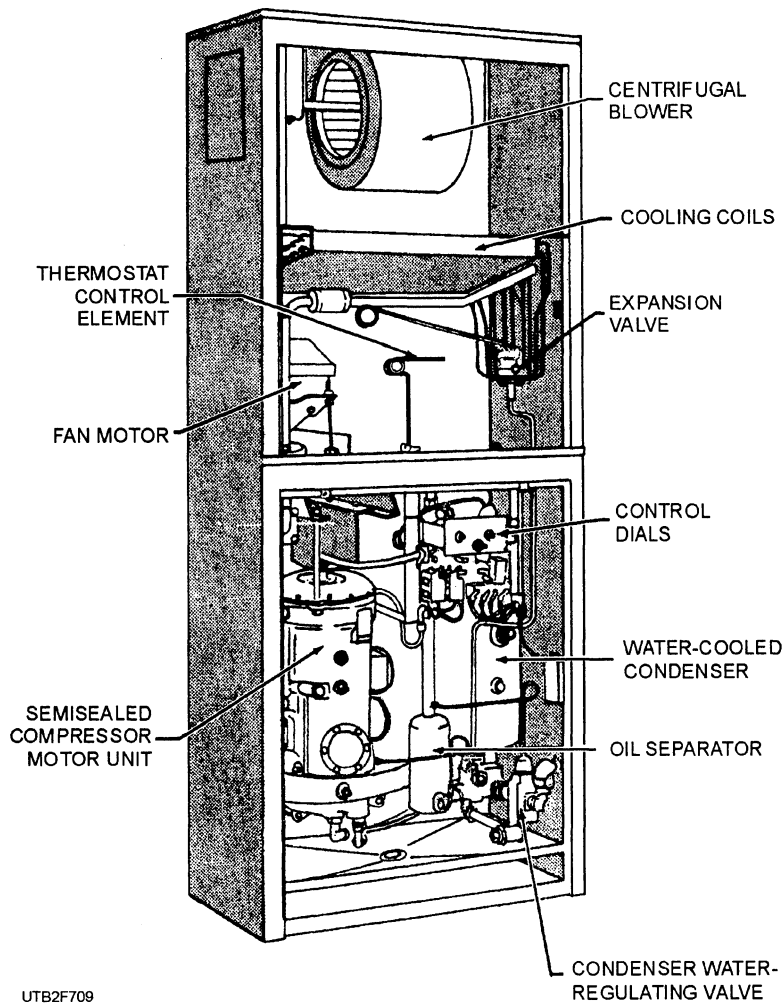

UTB2F709

Figure 7-9.—A floor-mounted air-conditioning unit.

renewed or cleaned weekly or more often if necessary. Always stop the blower when changing filters to keep loose dust from circulating through the system. When the filters are permanent, they should be returned to the shop for cleaning. At least once a year, the unit should be serviced. When the unit is designed with spray humidifier, spray nozzle, water strainers, and cooling coils, each device should be cleaned each month to remove water solids and scale. Cooling coil casings, drain pans, fan scrolls, and fan wheels should be wire brushed and repainted when necessary. Oiling and greasing of the blower and motor bearings should be performed as required.

HEAT PUMPS

A heat pump removes heat from one place and puts it into another. A domestic refrigerator is a heat pump in that it removes heat from inside a box and releases it on the outside. The only difference between a

refrigerator and a residential or commercial heat pump is that the latter can reverse its system. The heat pump is one of the most modern means of heating and cooling. Using no fuel, the electric heat pump automatically heats or cools as determined by outside temperature. The air type of unit works on the principle of removing heat from the atmosphere. No matter how cold the weather, some heat can always be extracted and pumped indoors to provide warmth. To cool during the hot months, this cycle is merely reversed with the unit removing heat from the area to be cooled and exhausting it to the outside air. The heat pump is designed to control the moisture in the air and to remove dust and pollen. Cool air, provided during hot weather, enters the area with uncomfortable moisture removed. In winter, when a natural atmosphere is desirable, air is not dried out when pumped indoors.

The heat pump is simple in operation (fig. 7-10). In summer, the evaporator is cooling and the condenser outside is giving off heat the evaporator picked up. In

winter, the condenser outside is picking up heat from the outside air because its temperature is lower than that of the outside air (until it reaches the balance point). This heat is then sent to the evaporator by the compressor and is given off into the conditioned space. A reversing valve is the key to this operation. The compressor always pumps in one direction, so the reversing valve changes the hot-gas direction from the condenser to the evaporator as indicated by the setting on the thermostat. The setting of the thermostat assures the operator of a constant temperature through an automatic change from heating to cooling anytime outside conditions warrant. Heat pumps are made not only for small homes but large homes and commercial buildings as well. The heat pump does not require an equipment room, and its minor noise is discharged into the atmosphere. The remote heat pump has only a blower and evaporator, which can be installed under the floor, in an attic, or other out-of-the-way location, depending on the application and its requirements. Supplemental heat can be added into the duct and be set to come on by a second stage of the thermostat, an outside thermostat, or both, depending on design of the system.

Heating Cycle

The initial heating demand of the thermostat starts the compressor. The reversing valve is de-energized during the heating mode. The compressor pumps the hot refrigerant gas through the indoor coil where heat is released into the indoor air stream. This supply of warmed air is distributed through the conditioned space. As the refrigerant releases its heat, it changes into a liquid, which is then transported to the outdoor coil. The outdoor coil absorbs heat from the air blown across the coil by the outdoor fan. The refrigerant changes from a liquid into a vapor, as it passes through the outdoor coil. The vapor returns to the compressor where it increases temperature and pressure. The hot refrigerant is then pumped back to the indoor coil to start another cycle. A graphic presentation of the nine steps of the cycle is shown in figure 7-11.

Cooling Cycle

Once the thermostat is put in the cooling mode, the reversing valve is energized. A cooling demand starts the compressor. The compressor pumps hot high-pressure gas to the outdoor coil where heat is released by the outdoor fan. The refrigerant changes into a liquid, which is transported to the indoor blower. The refrigerant absorbs heat from the indoor air of the

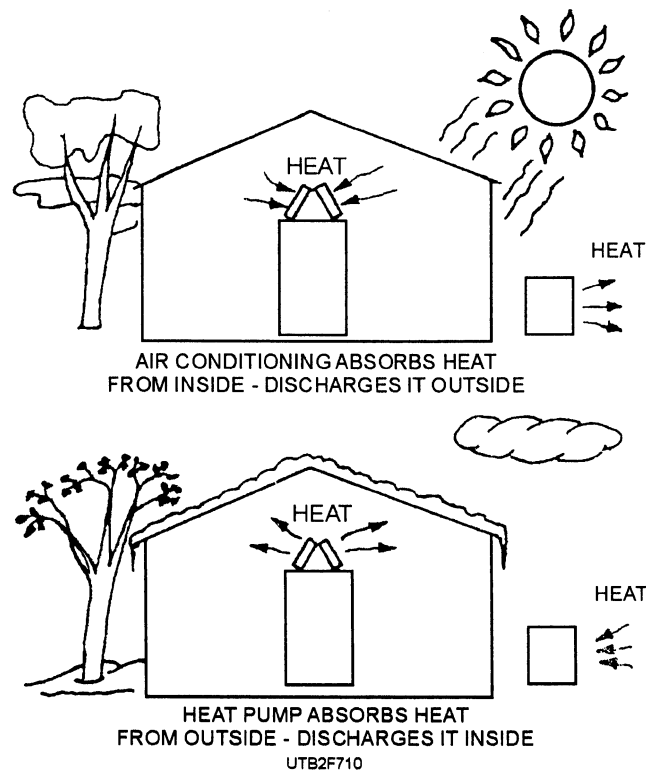
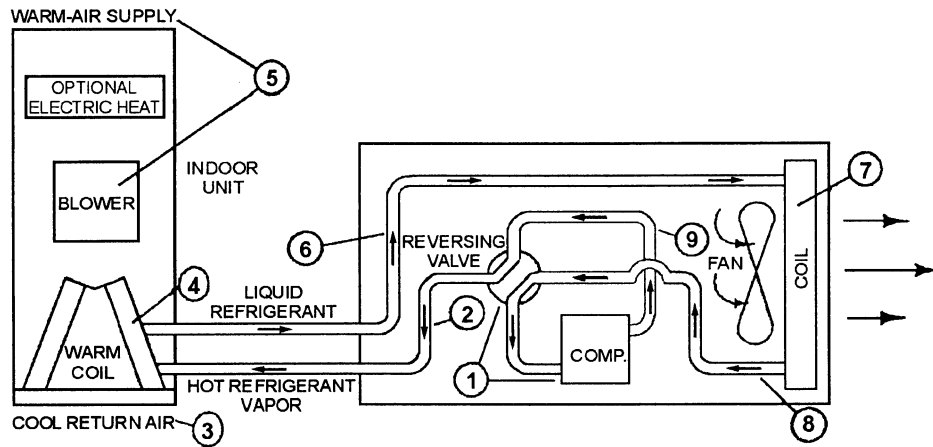

Figure 7-10. —Basic heat pump operation.



1. THE COMPRESSOR IS ENERGIZED WHILE THE REVERSING VALVE REMAINS DE-ENERGIZED.
2. THE COMPRESSOR PUMPS HOT REFRIGERANT GAS TO THE INDOOR COIL.
3. COOL RETURN AIR IS DRAWN OVER THE INDOOR COIL BY THE BLOWER.
4. THE REFRIGERANT RELEASES ITS HEAT INTO THE RETURN AIRSTREAM AND CONSEQUENTLY TURNS INTO A LIQUID.
5. THE WARMED SUPPLY OF AIR IS DISTRIBUTED THROUGHOUT THE CONTROLLED SPACE.
6. THE LIQUID REFRIGERANT IS TRANSPORTED TO THE OUTDOOR COIL.
7. THE REFRIGERANT ABSORBS HEAT FROM THE OUTDOOR AIR THAT IS BLOWN ACROSS THE COIL BY THE FAN.
8. THE REFRIGERANT TURNS INTO A COOL VAPOR WHICH IS DRAWN BACK TO THE COMPRESSOR.
9. THE COMPRESSOR INCREASES THE PRESSURE OF THE REFRIGERANT. THE HOT REFRIGERANT IS THEN PUMPED BACK TO THE INDOOR COIL TO START ANOTHER CYCLE.

UTB2F711

Figure 7-11.—Heating cycle.

supply air, which is distributed throughout the controlled space. This temperature change removes moisture from the air and forms condensate, which must be piped away. The compressor suction pressure draws the cool vapor back into the compressor where the temperature and pressure are greatly increased. This completes the cooling refrigerant cycle. A graphic presentation of the nine steps of the cycle is shown in figure 7-12.

Defrost Cycle

Heat pumps operating at temperatures below 45°F accumulate frost or ice on the outdoor coil. The relative humidity and ambient temperature affect the degree of accumulation. This ice buildup restricts the airflow through the outdoor coil, which consequently affects the system operating pressures. The defrost control detects this restriction and switches the unit into a defrost mode to melt the ice.

The reversing valve is energized and the machine temporarily goes into the cooling cycle where hot refrigerant flows to the outdoor coil. The outdoor fan stops at the same time, thus allowing the discharge temperature to increase rapidly to shorten the length of the defrost cycle. If there is supplemental heat, a defrost relay activates it to offset the cooling released by the indoor coil.

Supplemental Heat

As the outside temperature drops, the heat pump runs for longer periods until it eventually operates continually to satisfy the thermostat. The system "balance point" is when the heat pump capacity exactly matches the heating loss. The balance point varies between homes, depending on actual heat loss and the heat pump capacity. However, the balance point usually ranges between 15°F and 40°F. Either electric heat or fossil fuels provide the auxiliary heat.

Conventional heat pump applications use electric heaters downstream from the indoor coil. This design prevents damaging head pressures when the heat pump and auxiliary heat run simultaneously. The indoor coil can only be installed downstream from the auxiliary heat if a "fuelmaster" control system is used. This control package uses a two-stage heat thermostat with the first stage controlling heat pump operation and the second stage controlling furnace operation.

CHILLED-WATER SYSTEMS

Water chillers (figs. 7-13 and 7-14) are used in air conditioning for large tonnage capacities and for central refrigeration plants serving a number of zones, each with its individual air-cooling and air-circulating

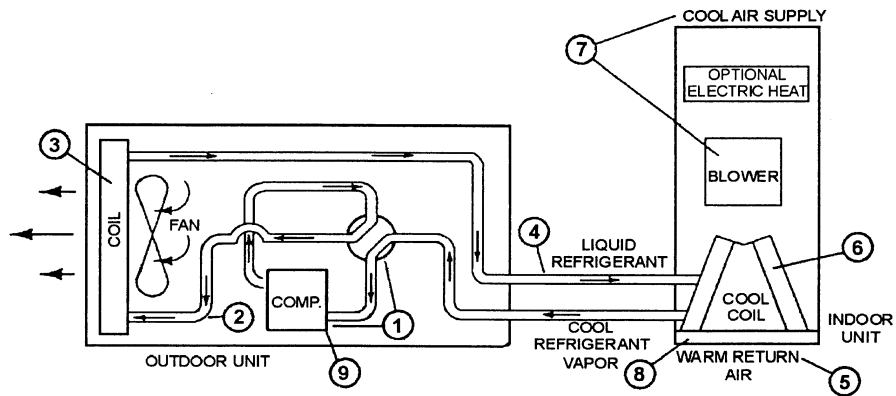

UTB2F712

Figure 7-12.—Cooling cycle.

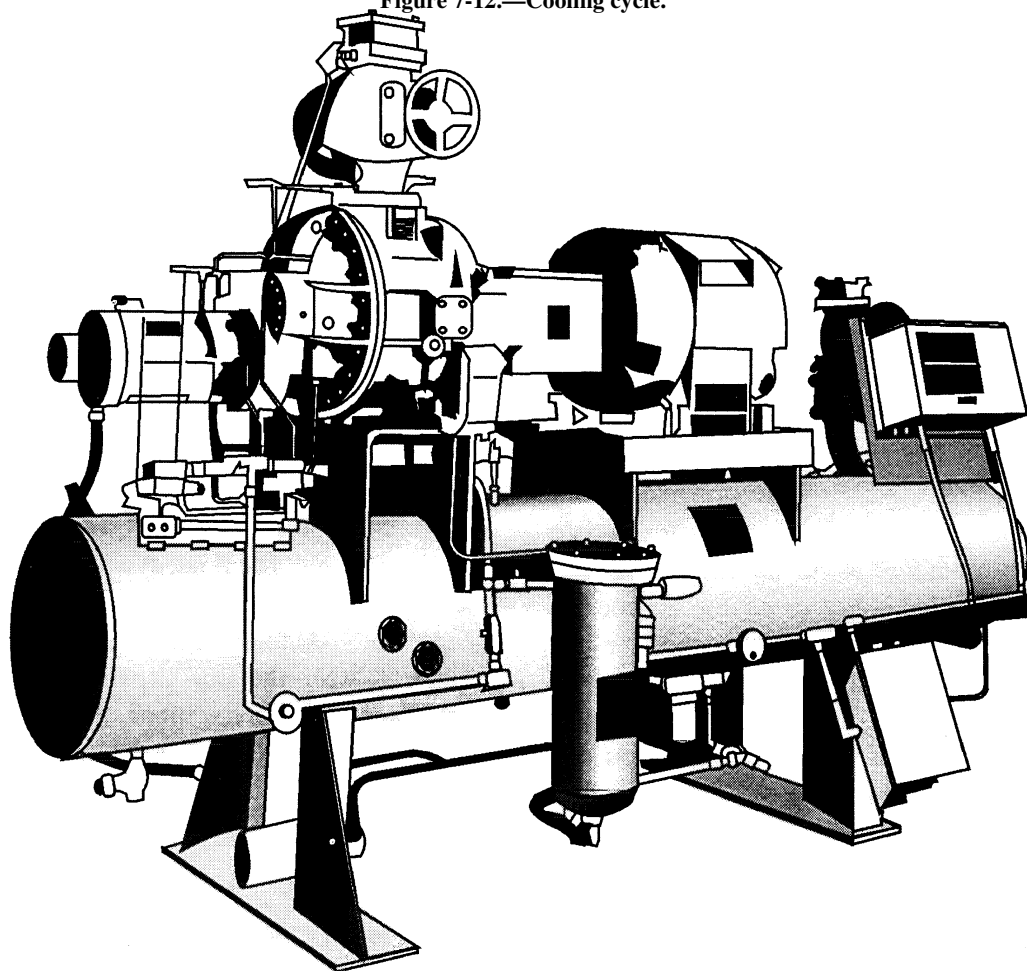

UTB2F713

Figure 7-13.—Rotary screw compressor unit.

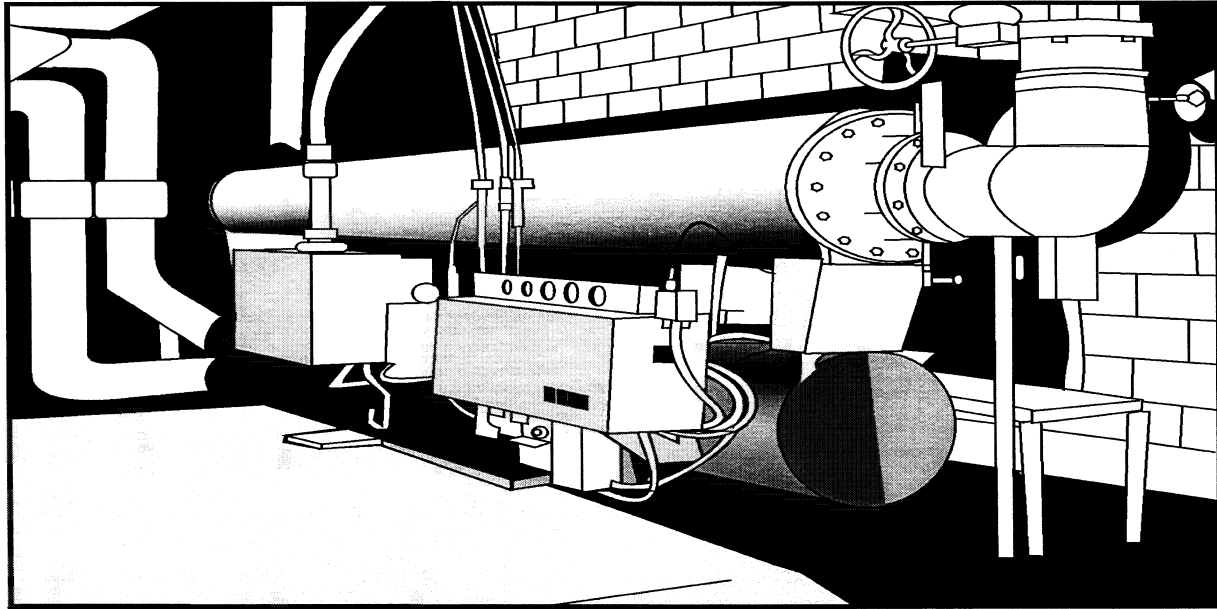

UTB2F714

Figure 7-14.—Two-stage semihermetic centrifugal unit.

units. An example is a large hospital with wings off a corridor. Air conditioning may be necessary in operating rooms, treatment suites, and possibly some recovery wards. Chilled water-producing and water-circulating equipment is in a mechanical equipment room. Long mains with many joints between condensing equipment and conditioning units increase the chance of leaks. Expensive refrigerant has to be replaced. It may be better to provide water-cooling equipment close to the condensing units and to circulate chilled water to remote air-cooling coils. Chilled water is circulated to various room-located coils by a pump, and the temperature of the air leaving each coil may be controlled by a thermostat that controls a water valve or stops and starts each cooling coil fan motor.

Types of Coolers

The two most commonly used water coolers (evaporators) for chilled water air conditioning are flooded shell-and-tube and dry-expansion coolers. The disadvantage of the flooded shell-and-tube cooler

is that it needs more refrigeration than other systems of equal size. Furthermore, water in tubes may freeze and split tubes when the load falls off.

Controls

Flooded coolers should be controlled with a low-pressure float control—a float valve placed so the float is about the same level as the predetermined refrigerant level. The float, as a pilot, moves a valve in the liquid line to control the flow of refrigerant to the evaporator. Automatic or thermostatic expansion valves control the dry-expansion coolers. The refrigerant is inside the tubes; therefore, freezing of water on the tubes is less likely to cause damage.

Condensers

The primary purpose of the condenser is to liquefy the refrigerant vapor. The heat added to the refrigerant in the evaporator and compressor must be transferred to some other medium from the condenser. This medium is the air or water used to cool the condenser.

WATER-COOLED CONDENSERS.—

Condensing water must be noncorrosive, clean, inexpensive, below a certain maximum temperature, and available in sufficient quantity. The use of corrosive or dirty water results in high maintenance costs for condensers and piping. Dirty water, as from a river, can generally be economically filtered if it is noncorrosive; corrosive water can sometimes be economically treated to neutralize its corrosive properties if it is clean. An inexpensive source of water that must be filtered and chemically treated will probably not be economical to use without some means of conservation, such as an evaporative condenser or a cooling tower.

Water circulated in evaporative condensers and cooling towers must always be treated to reduce the formation of scale, algae, and chalky deposits. Overtreatment of water, however, can waste costly chemicals and result in just as much maintenance as undertreatment.

SHELL-AND-COIL CONDENSERS.—

A shell-and-coil water-cooled condenser (fig. 7-15) is simply a continuous copper coil mounted inside a steel shell. Water flows through the coil, and the refrigerant vapor from the compressor is discharged inside the shell to condense on the outside of the cold tubes. In many designs, the shell also serves as a liquid receiver.

The shell-and-coil condenser has a low manufacturing cost, but this advantage is offset by the disadvantage that this type of condenser is difficult to service in the field. If a leak develops in the coil, the head from the shell must be removed and the entire coil pulled from the shell to find and repair the leak. A continuous coil is a nuisance to clean, whereas straight tubes are easy to clean with mechanical tube cleaners. In summary, with some types of cooling water, it may

be difficult to maintain a high rate of heat transfer with a shell-and-coil condenser.

SHELL-AND-TUBE CONDENSERS.—

The shell-and-tube water-cooled condenser shown in figure 7-16 permits a large amount of condensing surface to be installed in a comparatively small space. The condenser consists of a large number of 3/4- or 5/8-inch tubes installed inside a steel shell. The water flows inside the tubes while the vapor flows outside around the nest of tubes. The vapor condenses on the outside surface of the tubes and drips to the bottom of the condenser, which may be used as a receiver for the storage of liquid refrigerant. Shell-and-tube condensers are used for practically all water-cooled refrigeration systems.

To obtain a high rate of heat transfer through the surface of a condenser, it is necessary for the water to pass through the tubes at a fairly high velocity. For this reason, the tubes in shell-and-tube condensers are separated into several groups with the same water traveling in series through each of these various groups. A condenser having four groups of tubes is known as a four-pass condenser because the water flows back and forth along its length four times. Four-pass condensers are common although any reasonable number of passes may be used. The fewer the number of water passes in a condenser, the greater the number of tubes in each pass.

The friction of water flowing through a condenser with a few passes is lower than in one having a large number of passes. This means a lower power cost in pumping the water through a condenser with a smaller number of passes.

TUBE-WITHIN-A-TUBE CONDENSERS.—

The use of tube-within-a-tube for condensing purposes is popular because it is easy to make. Water passing

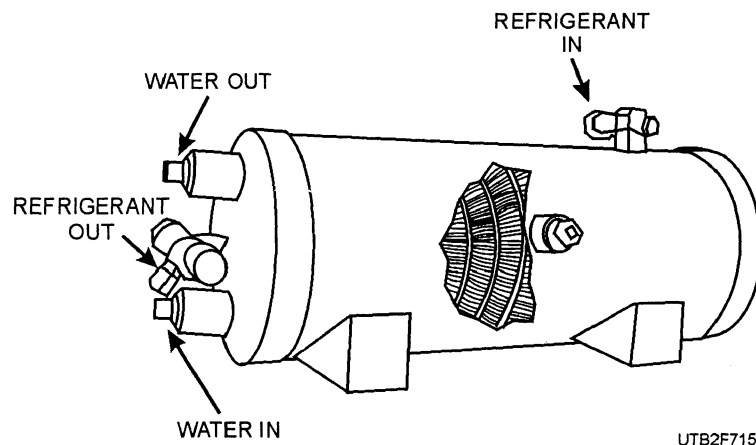

Figure 7-15.—A typical shell-and-coil water-cooled condenser.

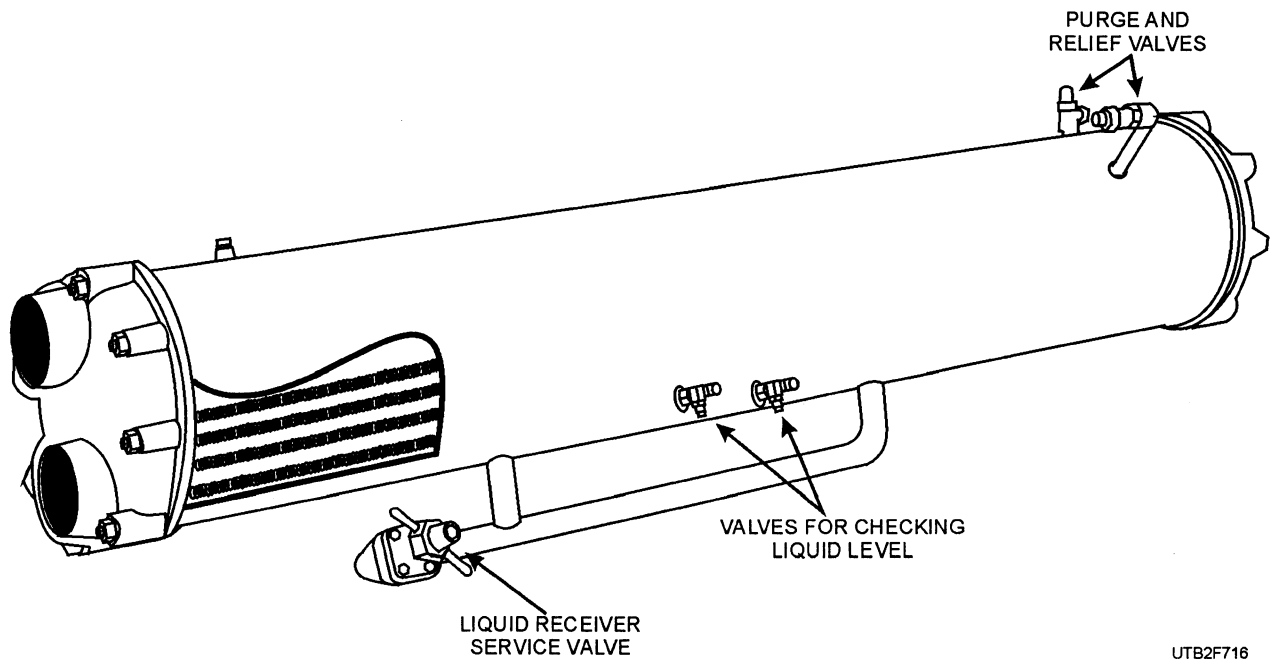

Figure 7-16.—A typical shell-and-tube condenser-liquid receiver.

UTB2F716

through the inner tube along with the exterior air condenses (fig 7-17) the refrigerant in the outer tube. This "double cooling" improves efficiency of the condenser. Water enters the condenser at the point where the refrigerant leaves the condenser. It leaves the condenser at the point where the hot vapor from the compressor enters the condenser. This arrangement is called counterflow design.

The rectangular type of tube-within-a-tube condenser uses a straight, hard copper pipe with

manifolds on the ends. When the manifolds are removed, the water pipes can be cleaned mechanically.

CLEANING WATER-COOLED CONDENSERS

You may be assigned to some activities where water-cooled condensers are used in the air-conditioning system. So, the Utilitiesman will probably have the job of cleaning the condensers. Information that assists you in cleaning water-cooled condensers is presented below.

Water contains many impurities—the content of which varies in different localities. Lime and iron are especially injurious; they form a hard scale on the walls of water tubes that reduces the efficiency of the condenser. Condensers can be cleaned mechanically or chemically.

Scale on tube walls of condensers with removable heads is removed by attaching a round steel brush to a rod and by working it in and out of the tubes. After the tubes have been cleaned with a brush, flush them by running water through them. Some scale deposits are harder to remove than others, and a steel brush may not do the job. Several types of tube cleaners for removing hard scale can usually be purchased from local sources. Be sure that the type selected does not injure water tubes.

The simplest method of removing scale and dirt from condenser tubes not accessible for mechanical

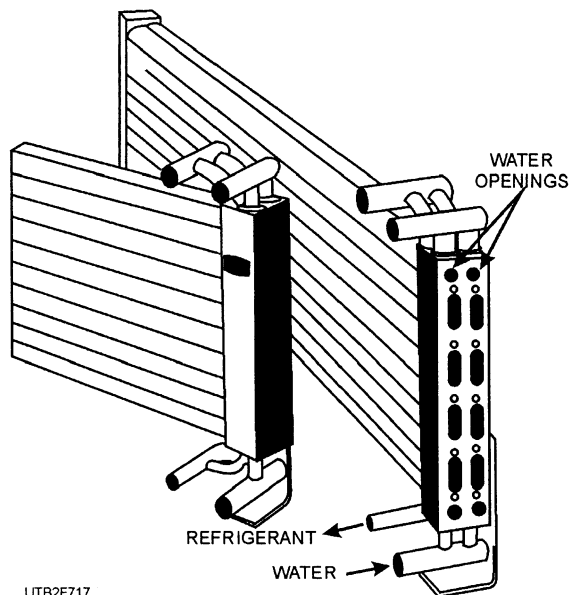

UTB2F717

Figure 7-17.—Tube-within-a-tube condenser designed to permit cleaning of water tubes.

cleaning is by using inhibited acid to clean coils or tubes through chemical action. Figure 7-18 shows the connections and the equipment for cleaning the condenser with an inhibited acid, both when the acid flows by gravity (view 1) and when forced circulation is used (view 2). When scale deposit is not great, gravity flow of the acid provides enough cleaning. When the deposit almost clogs the tubes, forced circulation should be used.

WARNING

Prevent chemical solution from splashing in your eyes and on your skin or clothing.

Equipment and connections for circulating inhibited acid through the condenser using gravity flow, as shown in figure 7-18, view 1, are as follows:

1. A rubber or plastic bucket for mixing solution. Do not use galvanized materials because prolonged contact with acid deteriorates such surfaces.
2. A crock or wooden bucket for catching the drainage residue.
3. One-inch steel pipe that is long enough to make the connections shown.
4. Fittings for 1-inch steel pipe. The vent pipe shown should be installed at the higher connection of the condenser.

Equipment and connections for circulating inhibited acid through the condenser using forced circulation, as shown in figure 7-18, are as follows:

1. A pump suitable for this application. A centrifugal pump and a 1/2-horsepower motor is recommended (30 gallons per minute at 35-foot head capacity).
2. A nongalvanized metal tank, stone or porcelain crock, or wooden barrel with a capacity of about 50 gallons with ordinary bronze or copper screening to keep large pieces of scale or dirt from getting into the pump intakes.
3. One-inch pipe that is long enough to make the piping connections shown.
4. Fittings for 1-inch steel globe valves. The vent pipe, as shown, should be installed at the higher connection of the condenser.

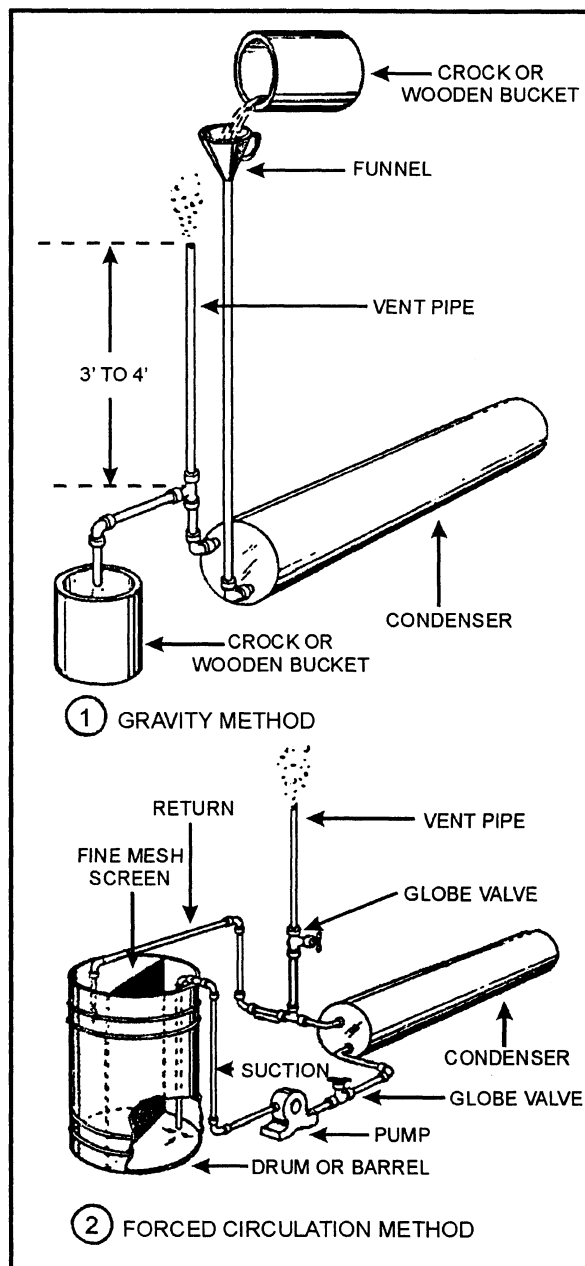

UTB2F718

Figure 7-18.—Cleaning water-cooled condensers with acid solution.

Handle the inhibited acid for cleaning condensers with the usual precautions observed when handling acids. It stains hands and clothing and attacks concrete and if an inhibitor is not present, it reacts with steel. Therefore, use every precaution to prevent spilling or splashing. When splashing might occur, cover the surfaces with burlap or boards. Gas produced during cleaning that escapes through the vent pipe is not harmful but prevents any liquid or spray from being carried through with the gas. The basic formula should

be maintained as closely as possible, but a variation of 5 percent is permissible. The inhibited acid solution is made up of the following:

1. Water.
2. Commercial hydrochloric (muriatic) acid with specific gravity of 1.19. Eleven quarts of acid should be used for each 10 gallons of water.
3. Three and two-fifths ounces of inhibitor powder for each 10 gallons of water used.
4. Place the required amount of water in a nongalvanized metal tank or wooden barrel, and add the necessary amount of inhibitor powder while stirring the water. Continue stirring the water until the powder is completely dissolved; then add the required quantity of acid.

WARNING

NEVER add water to acid; this mistake may cause an explosion.

In charging the system with an acid solution when GRAVITY FLOW is used, introduce the inhibited acid as shown in figure 7-18. Do not add the solution faster than the vent can exhaust the gases generated during cleaning. When the condenser has been filled, allow the solution to remain overnight.

When FORCED CIRCULATION is used, the valve in the vent pipe should be fully opened while the solution is introduced into the condenser but must be closed when the condenser is completely charged and the solution is circulated by the pump. When a centrifugal pump is used, the valve in the supply line may be fully closed while the pump is running.

The solution should be allowed to stand or be circulated in the system overnight for cleaning out average scale deposits. The cleaning time also depends on the size of the condenser to be cleaned. For extremely heavy deposits, forced circulation is recommended, and the time should be increased to 24 hours. The solution acts more rapidly if it is warm, but the cleaning action is just as thorough with a cold solution if adequate time is allowed.

After the solution has been allowed to stand or has been circulated for the required time through the condenser, it should be drained and the condenser thoroughly flushed with water. To clean condensers with removable heads by using inhibited acid, use the above procedure without removing the heads.

However, extra precaution must be exercised in flushing out the condenser with clear water after the acid has been circulated through the condenser to ensure acid removal from all water passages.

MAINTENANCE

A well-planned maintenance program avoids unnecessary downtime, prolongs the life of the unit, and reduces the possibility of costly equipment failure. It is recommended that a maintenance log be maintained for recording the maintenance activities. This action provides a valuable guide and aids in obtaining extended length of service from the unit. This section describes specific maintenance procedures, which must be performed as a part of the maintenance program of the unit. Use and follow the manufacturer's manual for the unit you are to do maintenance on. When specific directions or requirements are furnished, follow them. Before performing any of these operations, however, ensure that power to the unit is disconnected unless otherwise instructed.

WARNING

When maintenance checks and procedures must be completed with the electrical power on, care must be taken to avoid contact with energized components or moving parts. Failure to exercise caution when working with electrically powered equipment may result in serious injury or death.

Coil Cleaning

Refrigerant coils must be cleaned at least once a year or more frequently if the unit is located in a dirty environment. This action helps maintain unit operating efficiency and reliability. The relationship between regular coil maintenance and efficient/reliable unit operation is as follows:

- Clean condenser coils minimize compressor head pressure and amperage draw and promote system efficiency.
- Clean evaporator coils minimize water carry-over and helps eliminate frosting and/or compressor flood-back problems.

- Clean coils minimize required fan brake horsepower and maximize efficiency by keeping coil static pressure loss at a minimum.
- Clean coils keep the motor temperature and system pressure within safe operating limits for good reliability.

The following equipment is required to clean condenser coils: a soft brush and either a garden pump-up sprayer or a high-pressure sprayer. In addition, a high-quality detergent must be used. Follow the manufacturer's recommendations for mixing to make sure the detergent is alkaline with a pH value less than 8.5.

Specific steps required for cleaning the condenser coils are as follows:

1. Disconnect the power to the unit.

WARNING

Open the unit disconnect switch. Failure to disconnect the unit from the electrical power source may result in severe electrical shock and possible injury or death.

2. Remove enough panels from the unit to gain access to the coil.
3. Protect all electrical devices, such as motors and controllers, from dust and spray.
4. Straighten coil fins with a fin rake, if necessary.
5. Use a soft brush to remove loose dirt and debris from both sides of the coil.
6. Mix the detergent with water according to the manufacturer's instructions. The detergent and water solution may be heated to a maximum of 150°F to improve its cleaning ability.

WARNING

Do not heat the detergent and water solution to temperatures in excess of 150°F. High-temperature liquids sprayed on the coil exterior raise the pressure within the coil and may cause it to burst. Should this occur, the result could be both injury to personnel and equipment damage.

7. Place the detergent and water solution in the sprayer. If a high-pressure sprayer is used, be sure to follow these guidelines:

- Minimum nozzle spray angle is 15 degrees.
- Spray the solution perpendicular (at a 90-degree angle) to the coil face.
- Keep the sprayer nozzle at least 6 inches from the coil.
- Sprayer pressure must not exceed 600 psi.

CAUTION

Do NOT spray motors or other electrical components. Moisture from the spray can cause component failure.

8. Spray the side of the coil where the air leaves first; then, spray the other side (where the air enters). Allow the detergent and water solution to stand on the coil for 5 minutes.
9. Rinse both sides of the coil with cool water.
10. Inspect the coil and if it still appears dirty, repeat Steps 8 and 9.
11. Remove the protective covers installed in Step 3.
2. Replace all unit panels and parts, and restore electrical power to the unit.

Fan Motors

Inspect periodically for excessive vibration or temperature. Operating conditions vary the frequency of inspection and lubrication. Motor lubrication instructions are found on the motor tag or nameplate. If not available, contact the motor manufacturer for instructions.

To re-lubricate the motor, complete the following:

WARNING

Disconnect the power source for motor lubrication. Failure to do so may result in injury or death from electrical shock or moving parts.

1. Turn the motor off. Make sure it cannot accidentally restart.

2. Remove the relief plug and clean out any hardened grease.
3. Add fresh grease through the fitting with a low-pressure grease gun.
4. Run the motor for a few minutes to expel any excess grease through the relief vent.
5. Stop the motor and replace the relief plug

Fan Bearing Lubrication

Fan bearings with grease fittings or with grease line extensions should be lubricated with a lithium-base grease that is free of chemical impurities. Improper lubrication can result in early bearing failure. To lubricate the fan bearings, complete the following:

1. Lubricate the bearings while the unit is not running; disconnect the main power switch.
2. Connect a manual grease gun to the grease line or fitting.
3. Add grease, preferably when the bearing is warm, while turning the fan wheel manually until a light bead of grease appears at the bearing grease seal.

Filters

To clean permanent filters, wash under a stream of hot water to remove dirt and lint. Follow with a wash of mild alkali solution to remove old filter oil. Rinse thoroughly and let dry. Recoat both sides of the filter with filter oil and let dry. Replace the filter element in the unit.

CAUTION

Always install filters with directional arrows pointing toward the fans.

PERIODIC MAINTENANCE

Perform all of the indicated maintenance procedures at the intervals scheduled. This prolongs the life of the unit and reduces the possibility of costly equipment failure and downtime. A checklist should be prepared which lists the required service operations and the times at which they are to be performed. The following is a sample of such a list.

Weekly

1. Check the compressor oil level. If low, allow the compressor to operate continually at full load for 3 to 4 hours; check the oil level at 30-minute intervals. If the level remains low, add oil.
2. Observe the oil pressure. The oil pressure gauge reading should be approximately 20 to 35 psi above the suction pressure gauge reading.
3. Stop the compressor and check the shaft seal for excessive oil leakage. If found, check the seal with a refrigerant leak detector (open compressor only).
4. Check the condition of the air filters and air-handling equipment. Clean or replace filters, as necessary.
5. Check the general operating conditions, system pressures, refrigerant sight glass, and so forth.

Monthly

(Repeat Items 1 through 5)

6. Lubricate the fan and motor bearings, as necessary. Obtain and follow the manufacturer's lubricant specifications and bearing care instructions.
7. Check the fan belt tension and alignment.
8. Tighten all fan sheaves and pulleys. If found to be loose, check alignment before tightening.
9. Check the condition of the condensing equipment. Observe the condition of the condenser coil in the air-cooled condenser. Clean, as necessary. Check the cooling tower water in the water-cooled condenser. If algae or scaling is evident, water treatment is needed. Clean the sump strainer screen of the cooling tower.

Annually

(Repeat Items 1 through 9)

10. Drain all circuits of the water-condensing system. Inspect the condenser piping and clean any scale or sludge from the tubes of the condenser.
11. If a cooling tower or evaporative condenser is used, flush the pumps and sump tank. Remove any rust or corrosion from the metal surfaces and repaint.
12. Inspect all motor and fan shaft bearings for signs of wear. Check the shafts for proper end-play adjustment.

13. Replace worn or frayed fan belts.
14. Clean all water strainers.
15. Check the condition of the ductwork.
16. Check the condition of the electrical contacts of all contactors, starters, and controls. Remove the condensing unit control box cover and inspect the panel wiring. All electrical connections should be secure. Inspect the compressor and condenser fan motor contactors. If the contacts appear severely burned or pitted, replace the contactor. Do not clean the contacts. Inspect the condenser fan capacitors for visible damage.

Seasonal Shutdown

In preparation for seasonal shutdown, it is advisable to pump down the system and valve off the bulk of the refrigerant charge in the condenser. This action minimizes the quantity of refrigerant that might be lost due to any minor leak on the low-pressure side of the system, and, in the case of the open compressor, refrigerant that might leak through the shaft seal.

The following steps should be followed for the hermetic compressor pump down.

1. Close the liquid line shutoff valve at the condenser and start the system. When the suction pressure drops to the cutout setting of the low-pressure control, the compressor stops.
2. Open the compressor electrical disconnect switch to prevent the compressor from restarting, and then front-seat the compressor discharge and suction valves.

The following steps should be followed for the open compressor pump down.

1. If the system is not equipped with gauges, install a pressure gauge in the back-seat port of the compressor suction valve. Crack the valve off the backseat.
2. Close the liquid line shutoff valve at the condenser.
3. Manually open the liquid line solenoid valve(s). If the valves do not have manual opening devices, lower the setting of the system temperature controller so the valves are held open during the pump down.
4. Install a jumper wire across the terminals of the low-pressure switch. Since the system suction pressure is to be pumped down below the cutout setting of the

low-pressure switch, the jumper is necessary to keep the compressor running.

5. Start the compressor. Watching the suction pressure gauge, stop the compressor by opening its electrical disconnect switch when the gauge reading reaches 2 psig.
6. Front-seat the compressor discharge valve.

CAUTION

Do not allow the compressor to pump the suction pressure into a vacuum. A slight positive pressure is necessary to prevent air and moisture from being drawn into the system through minor leaks and through the now unmoving shaft seal.

7. Remove the jumper wire from the low-pressure control.
8. Remove the gauge from the port of the suction valve; replace the port plug and front-seat the valve.

The following steps are required for all systems:

1. Using a refrigerant leak detector, check the condenser and liquid receiver, if used, for refrigerant leaks.
2. Valve off the supply and return water connections of the water-cooled condenser. Allow the condenser to remain full of water during the off season. A drained condenser shell is more likely to rust and corrode than one full of water. If the condenser will be subjected to freezing temperatures, drain the water and refill it with an antifreeze solution.
3. Drain the cooling tower or evaporative condenser, if used; flush the sump and paint any rusted or corroded areas.
4. Open the system master disconnect switch and padlock it in the OPEN position.

Seasonal Start-up

The steps to follow for the seasonal start-up are as follows:

- 1 Perform all annual maintenance on the air-handling system and other related equipment.
- 2 Fill the water sump of the cooling tower or evaporative condenser, if used.

3. Open the shutoff valves of the water-cooled condenser.
4. Make certain the liquid line solenoid valve(s) is on automatic control.
5. Open the liquid line shutoff valve.
6. Back-seat the compressor suction and discharge valves.
7. Close the system master electrical disconnect switch.
8. Start the system.
9. After the system has operated for 15 to 20 minutes, check the compressor oil level sight glass, oil pressure, and the liquid line sight glass. If satisfactory, readjust the system temperature controller to the proper temperature setting.

SAFETY WARNINGS

Most units used for comfort air conditioning operate using R-12 or R-22 refrigerants that are not toxic except when decomposed by a flame. If the liquefied refrigerant contacts the eyes, the person suffering the injury must be taken to a doctor at once.

Should the skin come in contact with the liquefied refrigerant, the skin is to be treated as though it had been frostbitten or frozen. Refer to NAVEDTRA 13119, *Standard First Aid for Treatment of Frostbite*.

Do not adjust, clean, lubricate, or service any parts of equipment that are in motion. Ensure that moving parts, such as pulleys, belts, or flywheels, are fully enclosed with proper guards attached.

Before making repairs, open all electric switches controlling the equipment. Tag and lock the switches to prevent short circuits or accidental starting of equipment. When moisture and brine are on the floor, fatal grounding through the body is possible when exposed electrical connections can be reached or touched by personnel. De-energize electrical lines before repairing them, and ground all electrical tools.

- Q9. What are the two types of self-contained air-conditioning units?*
- Q10. Who normally operates a window air-conditioning unit?*
- Q11. Floor units are often referred to as what type of unit?*

- Q12. What type of unit cools and heats by reversing its cycle?*
- Q13. The reversing valve changes the direction of hot gas from what component to what other component in the system?*
- Q14. Heat pumps operating below 45°F develop what problem on the outside coils?*
- Q15. When the capacity of a heat pump matches the heat loss, it has reached what point?*
- Q16. What are the two most common evaporators used for water chiller systems?*
- Q17. Dry-expansion evaporators are controlled by what type of expansion valve?*
- Q18. Why is a tube-within-a-tube condenser popular?*
- Q19. Condensers can be cleaned in what two ways?*
- Q20. Refrigerant coils should be cleaned at least how often?*

MAJOR SYSTEM COMPONENTS AND CONTROLS

Learning Objectives: Recognize and understand different types of cooling towers, compressors, and controls. Understand basic maintenance requirements for cooling towers.

In this section, cooling towers and compressors which are the two major components of an air-conditioning system are discussed. In addition, the major control elements of an air-conditioned system are also covered.

COOLING TOWERS

Cooling towers are classified according to the method of moving air through the tower as natural draft, induced draft, or forced draft (figs. 7-19 and 7-20).

Natural Draft

The natural draft cooling tower is designed to cool water by means of air moving through the tower at the low velocities prevalent in open spaces during the summer. Natural draft towers are constructed of cypress or redwood and have numerous wooden decks of splash bars installed at regular intervals from the bottom to the top. Warm water from the condenser is

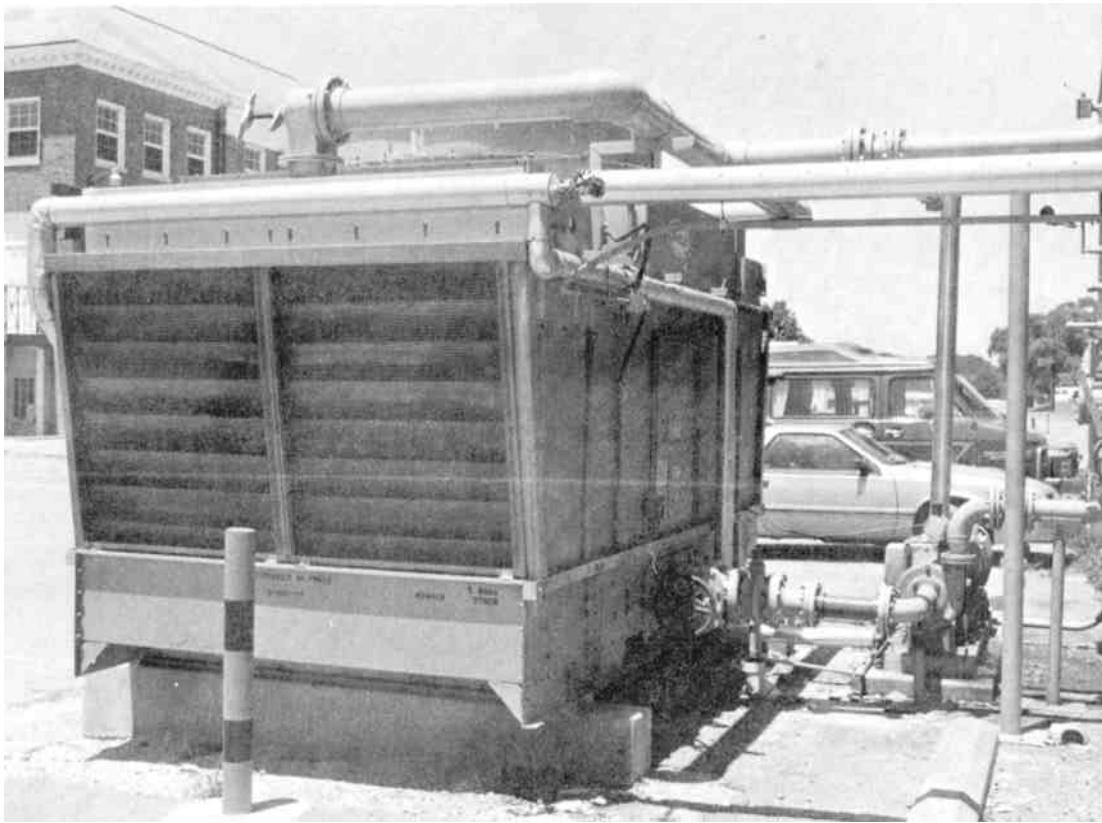

Figure 7-19.—A package tower with a remote, variable speed pump.

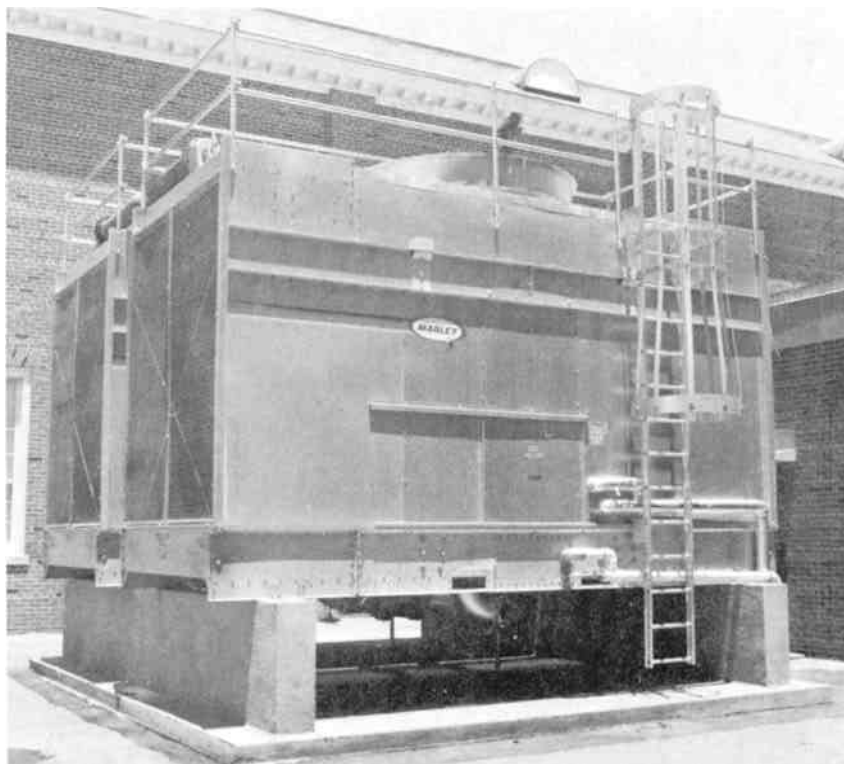

Figure 7-20.—Paralleled package towers.

flooded or sprayed over the distributing deck and flows by gravity to the water-collecting basin.

A completely open space is required for the natural draft tower since its performance depends on existing air currents. Ordinarily, a roof is an excellent location. Louvers must be placed on all sides of a natural draft tower to reduce drift loss.

Important design considerations are the wind velocity and the height of the tower. A wind velocity of 3-miles per hour is generally used for a design of natural draft cooling towers. The natural draft cooling tower was once the standard design for cooling condenser water in refrigeration systems up to about 75 tons. It is now rarely selected unless low initial cost and minimum power requirements are primary considerations. The drift loss and space requirements are much greater than for other cooling tower designs.

Induced Draft

An induced draft cooling tower is provided with a top-mounted fan that induces atmospheric air to flow up through the tower, as warm water falls downward. An induced draft tower may have only spray nozzles for water backup, or it may be filled with various slat and deck arrangements. There are several types of induced draft cooling towers.

In a counterflow induced draft tower (fig. 7-21, C), a top-mounted fan induces air to enter through the bottom of the tower and to flow vertically upward as the water cascades down through the tower. The counterflow tower is particularly well adapted to a restricted space as the discharge air is directed vertically upward, and if equipped with an inlet on each

side, requires only minimum clearance for air intake area. The primary breakup of water may be either by pressure spray or by gravity from pressure-filled flumes.

A parallel-flow induced draft tower (fig. 7-21, A) operates the same way as a counter-flow tower, except the top-mounted fan pulls the air in through the top of the tower and pushes it out the bottom. The airflow goes in the same direction as the water.

Comparing counterflow and parallel-flow induced draft towers of equal capacity, the parallel-flow tower is somewhat wider but the height is much less. Cooling towers must be braced against the wind. From a structural standpoint, therefore, it is much easier to design a parallel-flow than a counterflow tower, as the low silhouette of the parallel-flow type offers much less resistance to the force of the winds.

Mechanical equipment for counterflow and parallel-flow towers is mounted on top of the tower and is readily accessible for inspection and maintenance. The water-distributing systems are completely open on top of the tower and can be inspected during operation. This makes it possible to adjust the float valves and clean stopped-up nozzles while the towers are operating.

The cross-flow induced draft tower (fig. 7-21, B) is a modified version of the parallel-flow induced draft tower. The fan in a cross-flow cooling tower draws air through a single horizontal opening at one end and discharges the air at the opposite end.

The cooling tower is a packaged tower that is inexpensive to manufacture and is extremely popular for small installations. As a packaged cooling tower

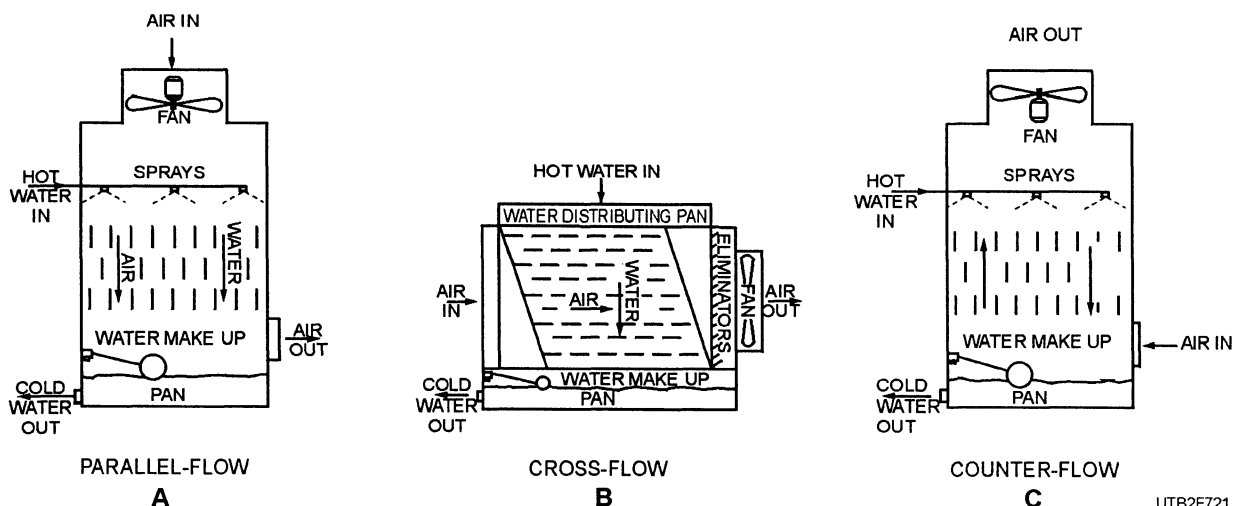

UTB2F721

Figure 7-21.—Types of induced fan cooling towers.

with piping and wiring in place, it is simple to install and may be placed wherever there is a clearance of 2 feet for the intake end and a space of 10 feet or more in front of the fan. The discharge end must not face the prevailing wind and should not be directed into a traffic area because drift loss may be objectionable.

In some situations, an indoor location for the cooling tower may be desirable. An induced draft tower of the counterflow or cross-flow design is generally selected for indoor installation. Two connections to the outside are usually required—one for drawing outdoor air into the tower and the other for discharging it back to the outside. A centrifugal blower is often necessary for this application to overcome the static pressure of the ductwork. Many options are possible as to the point of air entrance and air discharge. This flexibility is often important in designing an indoor installation. Primary water breakup is by pressure spray and fill of various types.

The induced draft cooling tower for indoor installation is a completely assembled packaged unit but is so designed that it can be partially disassembled to permit passage through limited entrances. Indoor installations of cooling towers are becoming more popular. External space restrictions, architectural compatibility, convenience for observation and maintenance all combine to favor an indoor location. The installation cost is somewhat higher than an outdoor location. Packaged towers are available in capacities to serve the cooling requirements of refrigeration plants in the 5- to 75-ton range.

Forced Draft

A forced draft cooling tower uses a fan to force air into the tower. In the usual installation, the fan shaft is in a horizontal plane. The air is forced horizontally through the fill and upward to be discharged out of the top of the tower.

Underflow cooling towers are an improved design of the forced draft tower that retains all the advantages of the efficient parallel-flow design. Air is forced into the center of the tower at the bottom. The air is then turned horizontally (both right and left) through fill chambers and is discharged vertically at both ends. By forcing the air to flow upward and outward through the fill and leave at the ends, operating noise is baffled and a desirable reduction of sound level is achieved. All sides of the underflow tower are smoothly encased with no louver openings. This blends with modern architecture and eliminates the necessity of masonry

walls or other screening devices oftentimes necessary to conceal cooling towers of other types.

Materials

Redwood has been the standard construction material for cooling towers for many years. Though cypress, as well as treated fir and pine, has been used occasionally, these materials have not enjoyed a wide application. Casings are constructed of laminated waterproof plywood. Such casings, as well as other noncorrosive materials at critical points, are essential in areas having a highly corrosive atmosphere. Nails, bolts, and nuts of copper or aluminum are almost standard practice for cooling tower construction.

Cooling towers of metal coated with plastic or bituminous materials that have air intake louvers and fill made of redwood have met with only limited success. The limited success is primarily because of the high maintenance cost as compared to wood towers.

Packaged towers with metal sides and wood fill are reasonably common. Some manufacturers have used sheet aluminum for siding for limited periods of time. Plastic slats have been used for fill material but have not proved satisfactory in all cases.

Fire ordinances of a large city may require that no wood be used in construction of cooling towers. With steel or some other fireproof casing and without fill, a cooling tower will comply with the most restrictive ordinances.

Maintenance

Recently, cooling towers have been linked to the spread of Legionnaire's disease. Several precautionary measures are recommended to help eliminate this problem. These include placing of cooling towers downwind and use of chloride compounds as disinfectants on a monthly maintenance schedule.

Water treatment is an important part of the operation of a cooling tower. The evaporation of water from a cooling tower leaves some solids behind. Recirculation of the water in the condenser cooling tower circuit, and the accompanying evaporation, causes the concentration of solids to increase. This concentration must be controlled or scale and corrosion will result.

Though draining the system from time to time and refilling with fresh water is one method of control, it is not recommended. Soon after refilling, the dissolved solids again build up to a dangerous concentration. A more common practice is to waste a certain amount of water continually from the system to the sewer. The water wasted is called blowdown. Blowdown is sometimes accomplished by wasting sump water through an overflow. A better practice, however, is to bleed the required quantity of blowdown from the warm water leaving the condenser on its way to the cooling tower. A mineral salt buildup (calcium bicarbonate concentration) of 10 grains per gallon is considered the maximum allowable concentration for untreated water in the sump if serious corrosion and scaling difficulties are to be avoided.

Cooling towers evaporate about 2 gallons of water every hour for each ton of refrigeration. A gallon of water weighs 8.3 pounds, and about 1,000 Btu is needed to evaporate 1 pound of water. Thus, to evaporate a gallon of water, $8.3 \times 1,000$ or 8,300 Btu is required.

In many instances, the makeup water contains dissolved salts in excess of 10 grains per gallon. It is obvious, then, that even 100 percent blowdown will not maintain a sump concentration of 10 grains. If the blowdown alone cannot maintain satisfactory control, then chemicals should be used.

Makeup water for a cooling tower is the sum of drift loss, evaporation, and blowdown. The drift loss for mechanical draft towers ranges from 0.1 percent of the total water being cooled for the better designed towers to as much as 0.3 percent. In estimating makeup water for a cooling tower, the higher value of 0.3 percent for drift loss is suggested. If the drift loss is actually less than this, the excess makeup water supplied is merely wasted down the overflow. This does, in effect, increase the amount of blowdown and is favorable from the viewpoint that the concentration of scale-forming compounds in the tower sump will be somewhat lower.

Redwood is a highly durable material; however, it is not immune to deterioration. The type of deterioration varies with the nature of the environmental conditions to which the wood is exposed. The principal types of deterioration are leaching, delignification, and microbiological attack.

Algae and slime are present in water and must be controlled chemically or the rate of heat transfer in the condenser will be materially reduced. Condenser

tubing, cooling tower piping, and metal surfaces in the water-circulating system must be protected from scale and corrosion.

Using too much of a chemical or using the wrong chemical is known as overtreatment. It can materially reduce the performance or the life of a cooling tower condenser circuit.

COMPRESSORS

A compressor is the machine used to withdraw the heat-laden refrigerant vapor from the evaporator, compress it from the evaporator pressure to the condensing pressure, and push it to the condenser. A compressor is merely a simple pump that compresses the refrigerant gas. Compressors may be divided into the following three types—reciprocating, rotary, and centrifugal. The function of compressing a refrigerant is the same in all three general types, but the mechanical means differ considerably. Rotary compressors are used in small sizes only, and their use is limited almost exclusively to domestic refrigerators and small water coolers. Centrifugal compressors are used in large refrigerating and air-conditioning systems (fig. 7-22).

Reciprocating Compressors

Reciprocating compressors are usually powered by electric motors, although gasoline, diesel, and turbine drivers are sometimes used. In terms of capacity, reciprocating compressors are made in fractional horsepower for small, self-contained air conditioners and refrigeration equipment, increasing in size to about 250 tons or more capacity in larger installations. Reciprocating compressors are furnished in open, semisealed, and sealed (hermetic) types.

OPEN.—An open type of compressor shaft is driven by an external motor. The shaft passes through the crankcase housing and is equipped with a shaft seal to prevent refrigerant and oil from leaking or moisture and air from entering the compressor. Pistons are actuated by crankshafts or eccentric drive mechanisms mounted on the shaft. Discharge valves are usually mounted in a plate over the pistons. Suction valves are usually mounted either in the pistons, if suction vapors enter the cylinder through the side of the cylinder or through the crankcase, or in the valve plate over the pistons, if suction vapors enter the cylinder through the head and valve plate.



- | | |
|--|---|
| <p>1. Centrifugal compressor with 5-inch impeller.</p> <p>2. Refrigerant cooled motor.</p> | <p>3. Control center.</p> <p>4. Chiller section.</p> <p>5. Condenser section.</p> |
|--|---|

Figure 7-22.—High-speed (36,000 rpm) single-stage centrifugal chiller.

Figure 7-23 shows a cross section of a typical open type of eccentric shaft compressor with suction valves in the valve plate of the head. Most belt-driven open type of compressors under 3 horsepower use a splash feed lubrication, but in larger size compressors, forced feed systems having positive displacement oil pumps are more common. The oil pump is usually driven from the rear end of the main shaft. Oil from the crankcase is forced under pressure through a hole in the main shaft to the seal, main bearing, and rod bearing, and through a hole in the rod up to the piston pins. Hermetically sealed compressor units used in window air conditioners are quite common in commercial sizes (under 5 horsepower) and are even made by some manufacturers in large tonnage sizes.

SEMISEALED.—Semisealed compressors are sometimes made in small sizes, but large tonnage units are always of the semisealed type. The primary

difference between a fully sealed and a semisealed motor compressor is that in semisealed types the valve plates, and in some units the oil pump, can be removed for repair or replacement. This type of construction is helpful in larger sizes that are so bulky they would cause considerable trouble and expense in shipping, removing, and replacing the unit as a whole. Figure 7-24 shows a small semisealed compressor.

Sealed or semisealed units eliminate the belt drive and crankshaft seal, both of which are among the chief causes of service calls. Sealed and semisealed compressors are made either vertical or horizontal. The vertical type (fig. 7-25) usually has a positive displacement oil pump that forces oil under pressure of 10 to 30 psi to the main bearings, rod, or eccentric and pins, although they are sometimes splash oiled.

Although oil pumps for forced feed lubrication are also used on horizontal hermetic compressors, oil

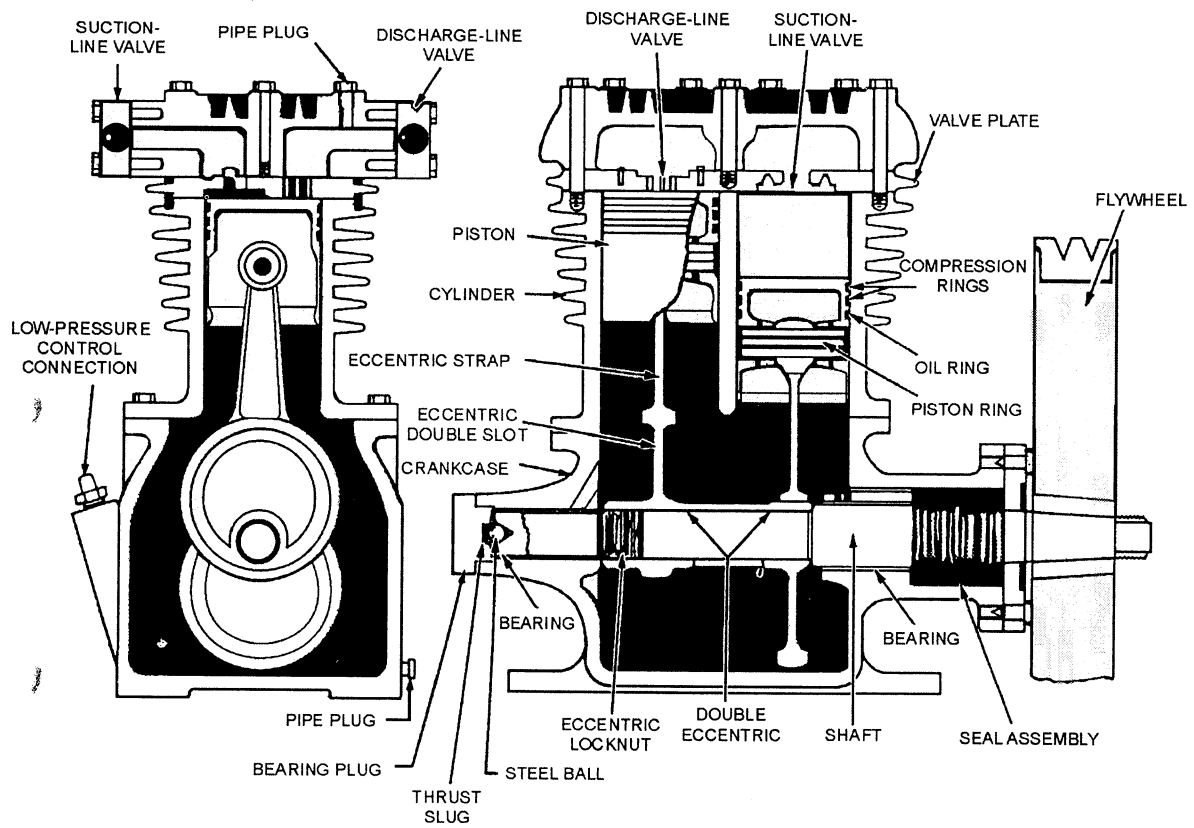

UTB2F723

Figure 7-23.—Cross section of an open type of reciprocating compressor.

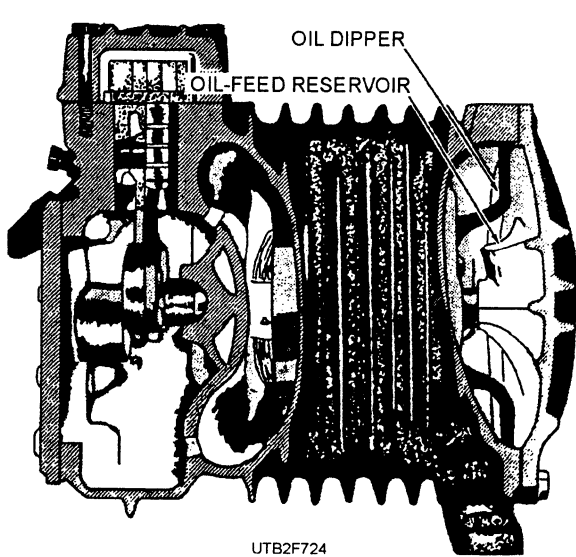

UTB2F724

Figure 7-24.—Small semisealed compressor.

circulation at low oil pressure may be provided by slingers, screw type of devices, and the like. Splash and other types of oil feed must not be considered inferior forced feed. With good design, they lubricate well. It is most important to maintain the proper oil level, use a correct grade of oil, and keep the system clean and free of dirt and moisture. This is true for all compression refrigeration systems, especially those equipped with

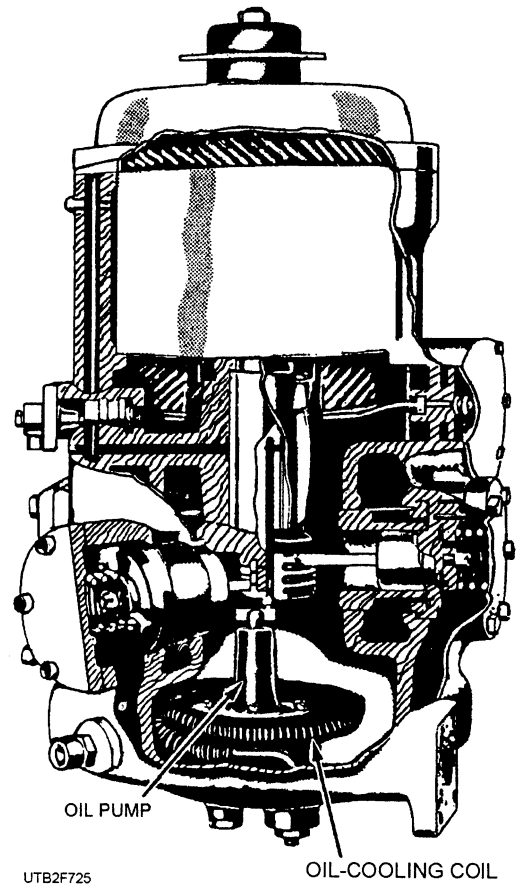

UTB2F725

OIL-COOLING COIL

Figure 7-25.—Vertical semisealed compressor.

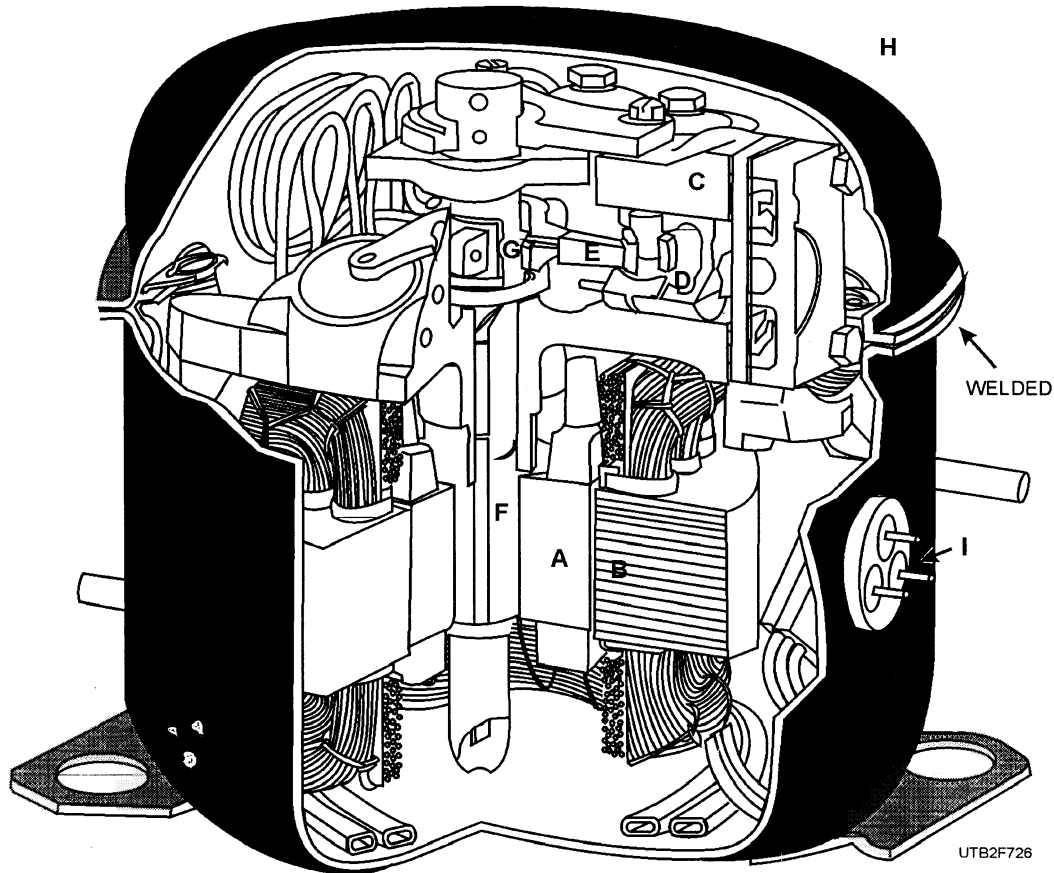

Figure 7-26.—Reciprocating hermetic compressor. (A) Motor rotor; (B) Motor stator; (C) Compressor cylinder; (D) Compressor piston; (E) Connecting rod; (F) crankshaft; (G) Crank throw; (H) Compressor shell (I) Glass sealed electrical connection.

hermetically sealed units whose motor windings may be attacked by acids or other corrosive substances introduced into the system or formed by the chemical reaction of moisture, air, or other foreign substances.

HERMETIC.—The term *sealed* or *hermetic* unit merely means that the motor rotor and compressor crankshaft of the refrigeration system are made in one piece, and the entire motor and compressor assembly is put into a gastight housing that is welded shut (fig. 7-26). This method of assembly eliminates the need for certain parts found in the open unit. These parts are as follows: motor pulley, belt, compressor flywheel, and compressor seal. The elimination of the preceding parts in the sealed unit similarly does away with the following service operations: replacing motor pulleys, replacing flywheels, replacing belts, aligning belts, and repairing or replacing seals. When it is realized there are major and minor operations that maintenance personnel must perform and the sealed unit dispenses

with only five of these, it can be readily seen that servicing is still necessary.

Rotary Compressors

Rotary compressors are generally associated with refrigerators, water coolers, and similar small capacity equipment. However, they are available in larger sizes. A typical application of a large compressor is found in compound compressor systems where high capacity must be provided with a minimum of floor space.

In a rotary compressor (fig. 7-27), an eccentric rotor revolves within a housing in which the suction and discharge passages are separated by means of a sealing blade. When the rotating eccentric first passes this blade, the suction area is at a minimum. Further rotation enlarges the space and draws in the charge of refrigerant. As the eccentric again passes the blade, the gas charge is shut off at the inlet, compressed, and discharged from the compressor. There are variations

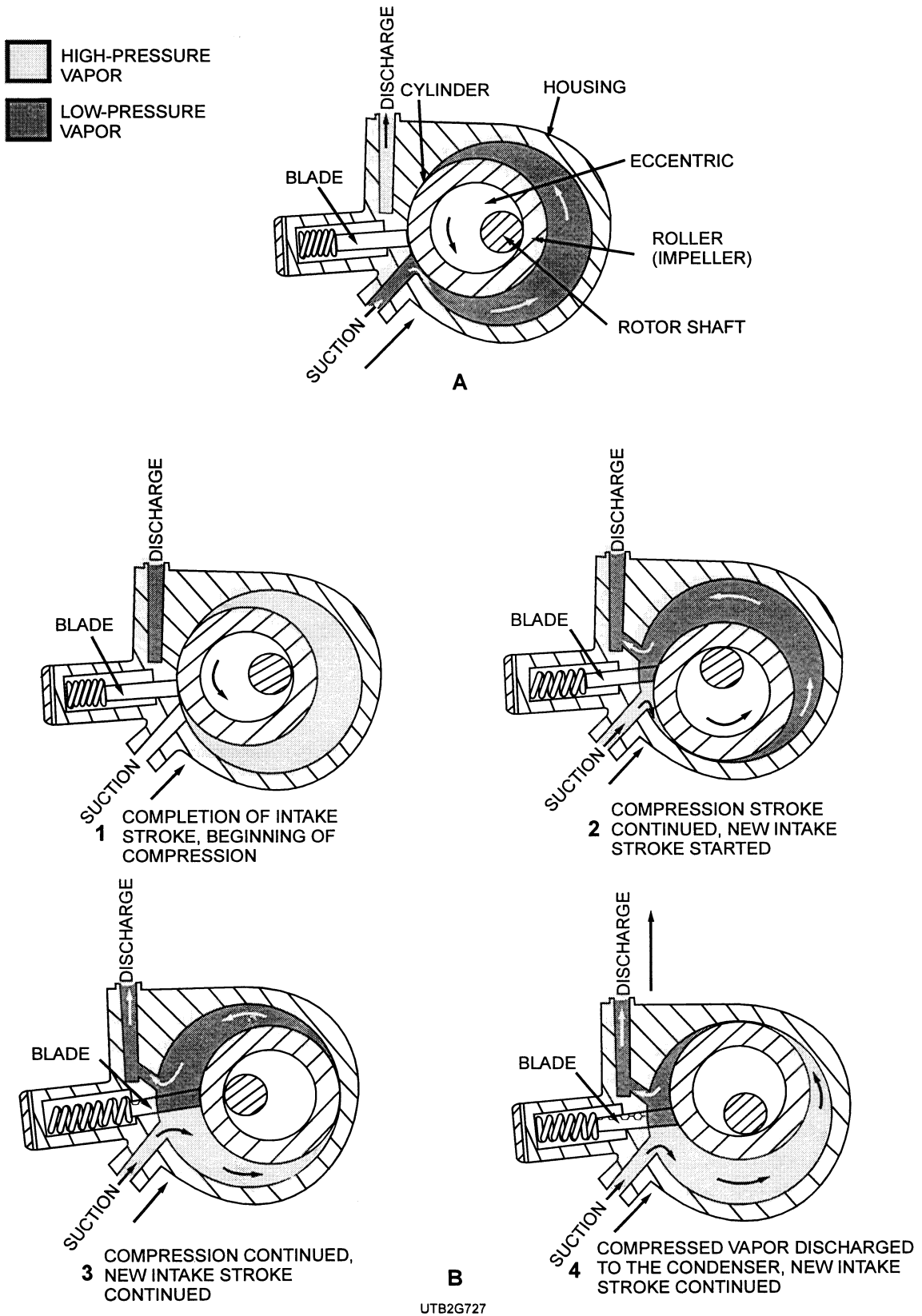

Figure 7-27.—Rotary compressor: A. Part identification; B. Operation.

of this basic design, some of which provide the rotor with blades to trap and compress the vapor.

Centrifugal Compressors

Centrifugal compressors are used in large refrigeration and air-conditioning systems, handling large volumes of refrigerants at low-pressure differentials. Their operating principles are based on the use of centrifugal force as a means of compressing and discharging the vaporized refrigerant. Figure 7-28 is a cutaway view of one type of centrifugal compressor. In this application, one or two compression stages are used, and the condenser and evaporator are integral parts of the unit. The heart of this type of compressor is the impeller wheel.

Scroll Compressors

A scroll compressor has two different offset spiral disks to compress the refrigerant vapor. The upper scroll is stationary, while the lower scroll is the driven scroll. Intake of refrigerant is at the outer edge of the

driven scroll, and the discharge of the refrigerant is at the center of the stationary scroll. The driven scroll is rotated around the stationary or "fixed" scroll in an orbiting motion. During this movement, the refrigerant vapor is trapped between the two scrolls. As the driven scroll rotates, it compresses the refrigerant vapor through the discharge port. Scroll compressors have few moving parts and have a very smooth and quiet operation.

CONTROLS

Controls used in air conditioning are generally the same as for refrigeration systems—thermostats, humidistats, pressure and flow controllers, and motor overload protectors (fig. 7-29).

Thermostats

The thermostat is an adjustable temperature-sensitive device, which through the opening and closing of its contacts controls the operation of the

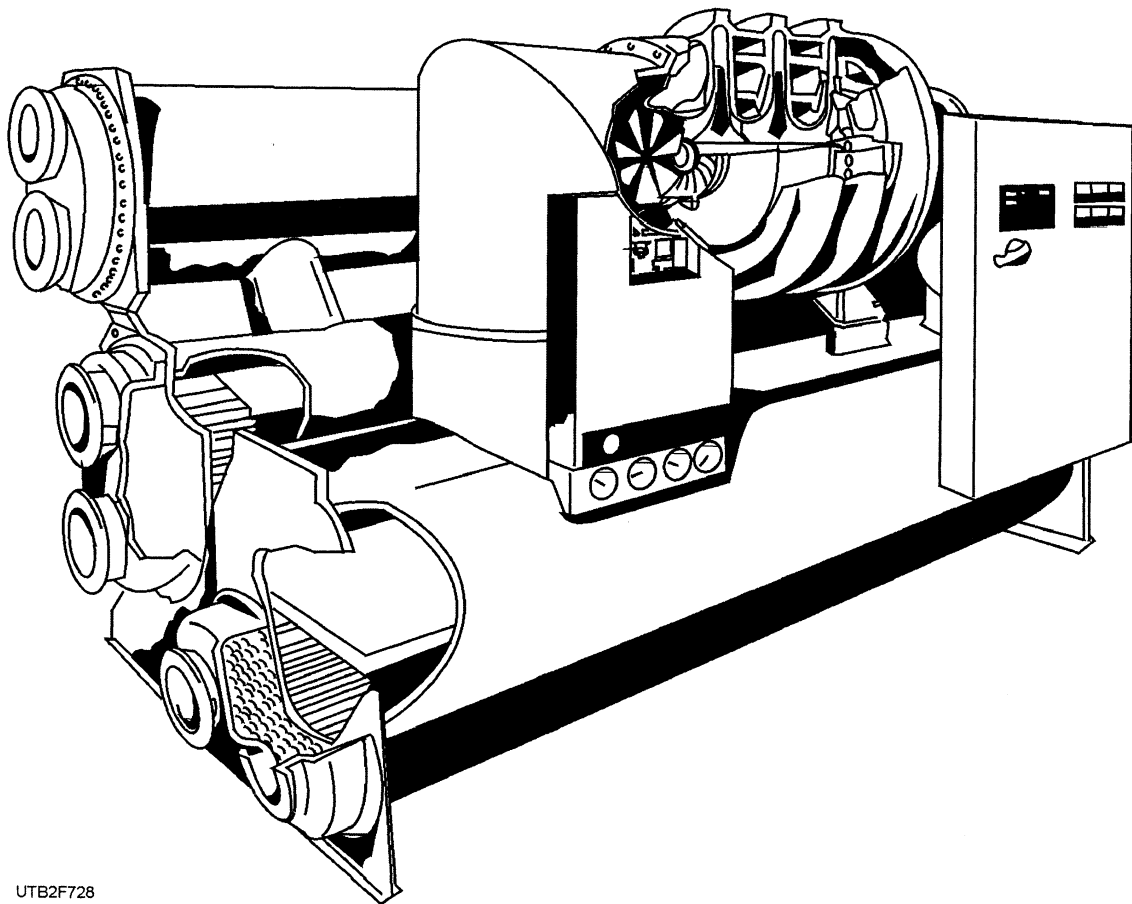

UTB2F728

Figure 7-28.—Cutaway view of one type of centrifugal compressor.

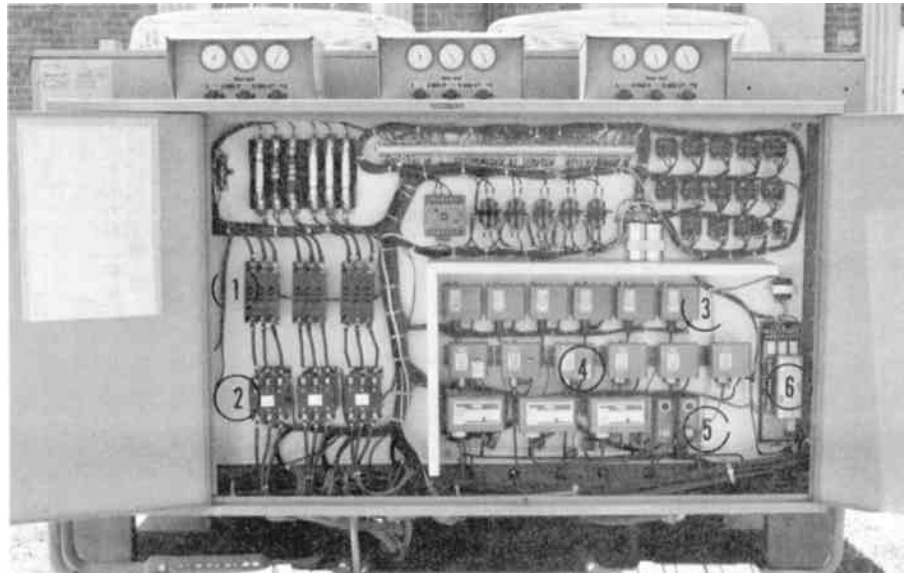

- | | |
|-------------------------|------------------------------------|
| 1. Compressor breakers. | 4. High-pressure controls. |
| 2. Compressor starters. | 5. Oil failure controls. |
| 3. Fan cycle controls. | 6. Solid-state staging thermostat. |

Figure 7-29.—Packaged air-cooled chiller controls.

cooling unit. The temperature-sensitive element may be a bimetallic strip or a confined, vaporized liquid.

The thermostats used with refrigerative air conditioners are similar to those used with heating equipment, except their action is reversed. The operating circuit is closed when the room temperature rises to the thermostat control point and remains closed until the cooling unit decreases the temperature enough. Also, cooling thermostats are not equipped with heat-anticipating coils.

Wall type of thermostats most common for heating and air conditioning in the home and on some commercial units use a bimetallic strip and a set of contacts, as shown in figure 7-30. This type of thermostat operates on the principle that when two dissimilar metals, such as brass and steel, are bonded together, one tends to expand faster than the other does when heat is applied. This causes the strip to bend and close the controls.

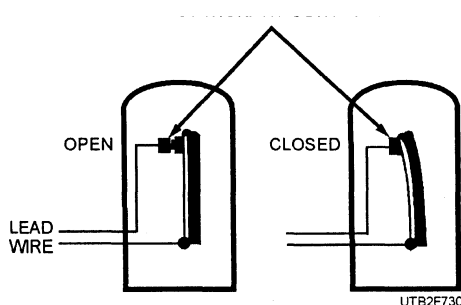

Figure 7-30.—Bimetallic thermostat.

As a Utilitiesman, you may be required to make an adjustment that sets the temperature difference between the cut-in and cutout temperatures. For example, if the system is set to cut in at 76°F and cut out at 84°F, then the differential is 8°F. This condition prevents the unit from cycling continually as it would if there were no differential.

Humidistats

A room "humidistat" may be defined as a humidity-sensitive device controlling the equipment that maintains a predetermined humidity of the space where it is installed. The contact of the humidistat is opened and closed by the expansion or contraction of natural blonde hairs from human beings, which is one of the major elements of this control. It has been found that these types of hairs are most sensitive to the moisture content of the air surrounding them.

Pressure-Flow Controllers

Pressure-flow controllers are discussed in chapter 6. The purpose of these controllers in air conditioning is to act as safety switches for the system, so if either the head pressure is too high or suction pressure too low, the system will be secured regardless of the position of the operating switches.

Refrigerant-Flow Controllers

The refrigerant-flow controllers used with air conditioners are also similar to the ones discussed in chapter 6. These controllers are either of the capillary type or externally equalized expansion valve type and

are usually of larger tonnage than those used for refrigerators.

Motor Overload Protectors

When the compressor is powered by an electric motor, either belt driven or as an integral part of the compressor assembly, the motor is usually protected by a heat-actuated overload device. This is in addition to the line power fuses. The heat to actuate the overload device is supplied by the electrical energy to the motor, as well as the heat generated by the motor

itself. Either source of heat or a combination of the two, if too much, causes the overload device to open and remove the motor from the line.

Figure 7-31 shows a thermal-element type of overload cutout relay. It is housed in the magnetic starter box. On current overload, the relay contacts open, allowing the holding coil to release the starting mechanism, thereby stopping the motor.

An oil failure cutout switch is provided on many systems to protect the compressor against oil failure. The switch is connected to register pressure differential between the oil pump and the suction line. Figure 7-32 shows a typical oil failure cutout switch. The switch contains two bellows, which work against each other, and springs for adjusting. Tubing from the oil pump is connected to the bottom bellows of the switch. Tubing from the suction line is connected to the upper bellows. When a predetermined pressure differential is not maintained, a pair of contacts in the switch is opened and breaks the circuit to the compressor motor. A heating element with a built-in delay is in the switch to provide for starting the compressor when oil pressure is low.

The water-regulating valve used with a water-cooled condenser responds to a predetermined condensing pressure. A connection from the discharge side of the compressor to the valve transmits condensing pressure directly to a bellows inside the

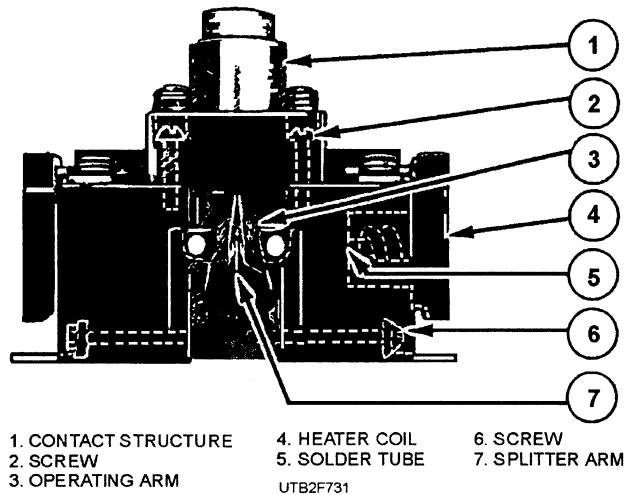

Figure 7-31.—Thermal overload relay.

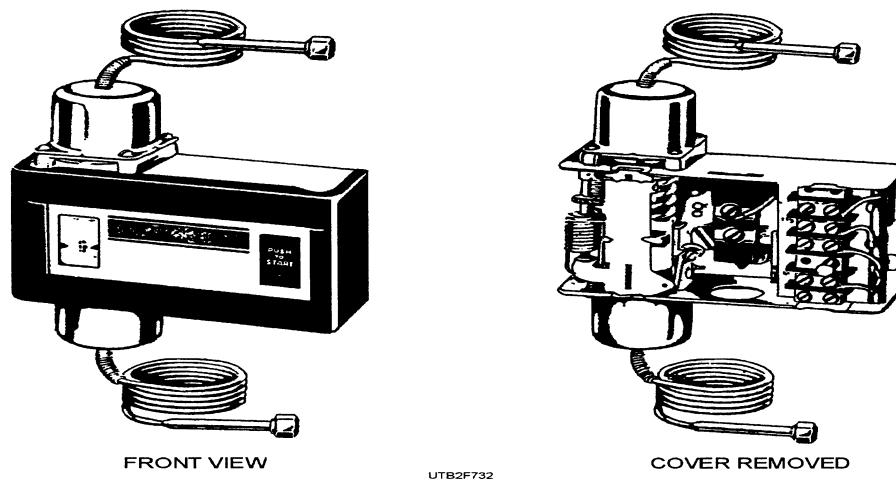

Figure 7-32.—Oil failure cutout switch.

valve. High pressure opens the valve, allowing a greater flow of water; low pressure throttles the flow. Use of such a valve provides for a more economical use of water for condensing. Figure 7-33 shows a typical water-regulating valve. When condenser water is supplied by a cooling tower, water-regulating valves are not customarily used because the cooling tower fan

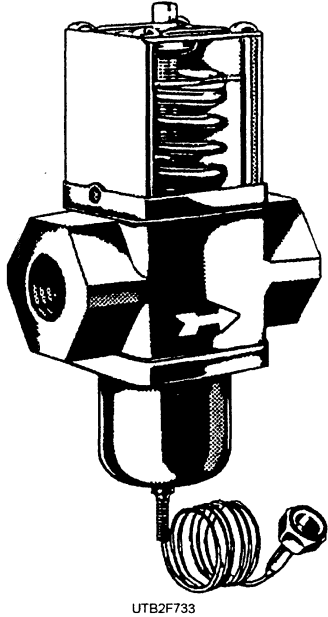

Figure 7-33.—Water-regulating valve.

and circulating pump are wired into the compressor motor control circuit.

Step Controller

The step controller contains a shaft upon which is mounted a series of cams. Rotation of the cams, in turn, operates electrical switches. Through adjustment of the cams on the shaft, the temperature at which each switch is to close and open (differential) is established. In addition, the switches may be adjusted to operate in almost any sequence (fig. 7-34).

TROUBLESHOOTING

Table Z of appendix II is a troubleshooting chart generally applicable to all types of air conditioners. Most manufacturers include more detailed and specific information in publications pertaining to their units. If you find that there is no manual with the unit when it is unpacked, write to the manufacturer and request one as soon as possible.

- Q21. How are cooling towers classified?
- Q22. A wind velocity of 8 mph is generally used to design natural draft cooling towers. True /False
- Q23. Counter flow, parallel flow, and cross flow are types of what class of cooling tower?

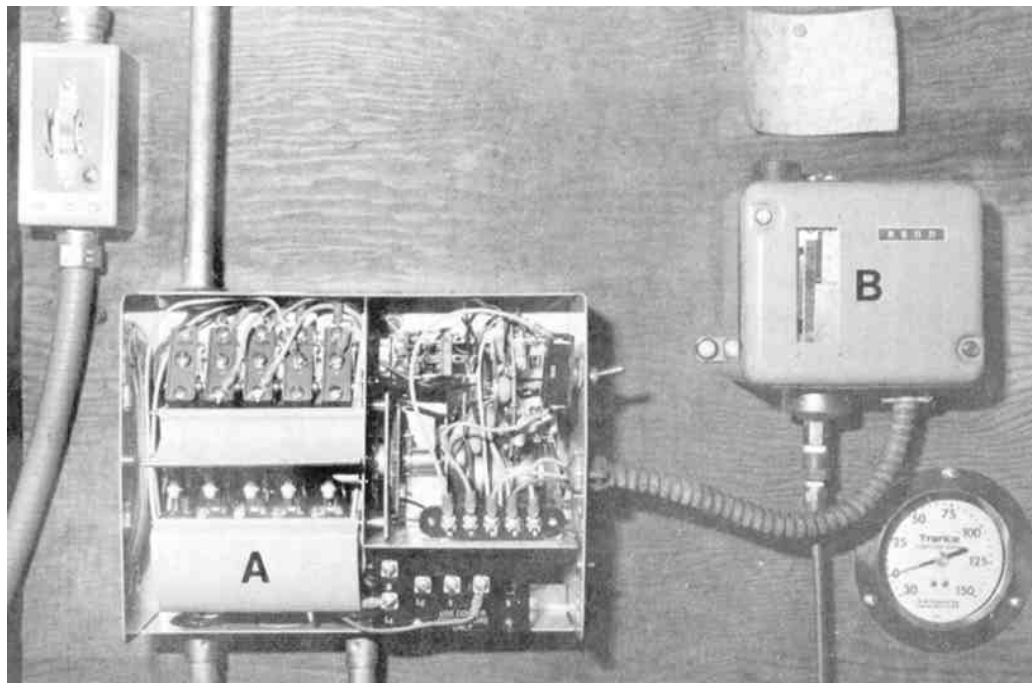

Figure 7-34.—Step controller and pressure-sensor configuration. (A) Step controller with modulating motor, single-pole double-throw mini switches, and mouse trap relay assembly; (B) Pressure sensor that controls the step controller.

- Q24. *What type of cooling tower is installed indoors?*
- Q25. *Forced draft underflow towers retain the advantages of what other type of cooling tower?*
- Q26. *Air intake louvers and fill are made of what material?*
- Q27. *Cooling towers evaporate approximately how much water every hour for each ton of refrigeration?*
- Q28. *Rotary compressors are used in what type of units?*
- Q29. *Semissealed and sealed compressors have reduced service requirements because of the elimination of what part?*
- Q30. *What control is temperature sensitive and controls the operation of the cooling unit?*
- Q31. *What device maintains humidity at a predetermined point?*
- Q32. *What causes a motor to shut down when a motor is too hot?*

AUTOMOTIVE AIR CONDITIONING

Learning Objective: Understand the basic principles of operation, maintenance, and repair of automotive air conditioning.

Vehicle air conditioning is the cooling (refrigeration) of air within a passenger compartment. Refrigeration is accomplished by making practical use of three laws of nature—heat transfer, latent heat of vaporization, and the effects of pressure on boiling or condensation. The first two laws are discussed in chapter 6 of this TRAMAN; the practical application of the third is outlined below.

EFFECT OF PRESSURE ON BOILING OR CONDENSATION

The saturation temperature (the temperature where boiling or condensation occurs) of a liquid or vapor increases or decreases according to the pressure exerted on it.

In the fixed orifice tube refrigerant system, liquid refrigerant is stored in the condenser under high pressure (fig. 7-35). When the liquid refrigerant is released into the evaporator by the fixed orifice tube,

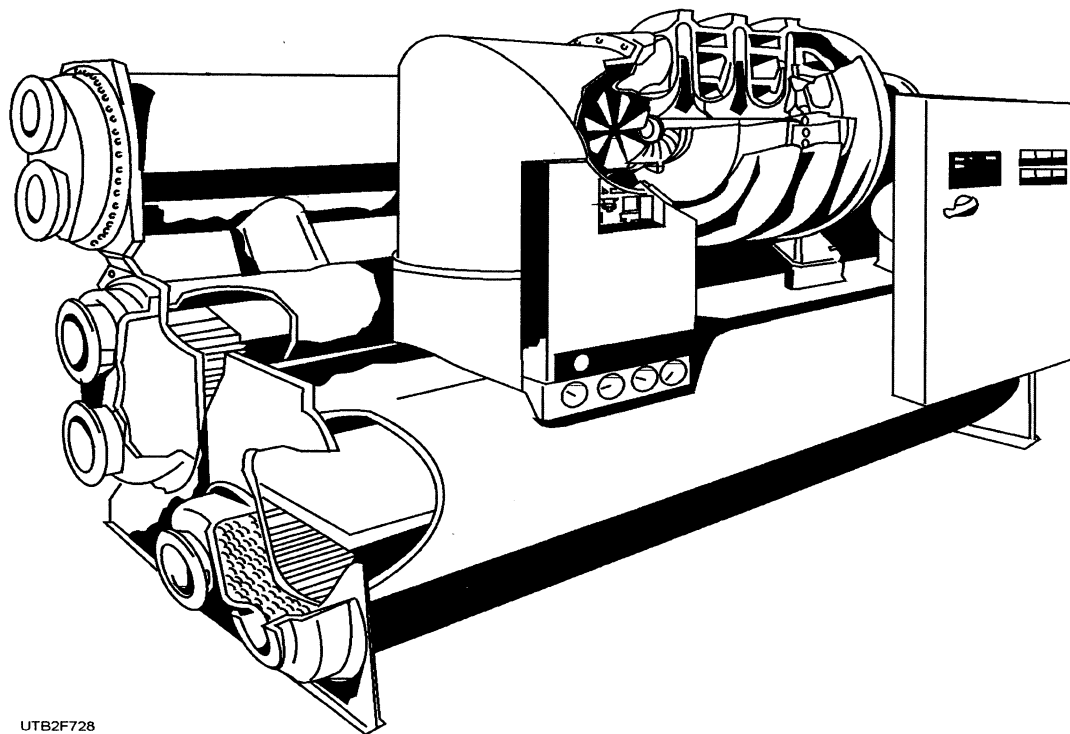

UTB2F728

Figure 7-35.—Air-conditioning refrigeration system-fixed orifice.

the resulting decrease in pressure and partial boiling lowers its temperature to its new boiling point. As the refrigerant flows through the evaporator, passenger compartment air passes over the outside surface of the evaporator coils. As it boils, the refrigerant absorbs heat from the air and thus cools the passenger compartment. The heat from the passenger compartment is absorbed by the boiling refrigerant and hidden in the vapor. The refrigeration cycle is now under way. The following functions must be done to complete the refrigeration cycle:

1. Disposing of the heat in the vapor
2. Converting the vapor back to liquid for reuse
3. Returning of the liquid to the starting point in the refrigeration cycle

The compressor and condenser (fig. 7-35) perform these functions. The compressor pumps the refrigerant vapor (containing the hidden heat) out of the evaporator and suction accumulator drier, then forces it under high pressure into the condenser which is located in the outside air stream at the front of the vehicle. The increased pressure in the condenser raises the refrigerant condensation or saturation temperature to a point higher than that of the outside air. As the heat transfers from the hot vapor to the cooler air, the refrigerant condenses back to a liquid. The liquid under high pressure now returns through the liquid line to the fixed orifice tube for reuse.

It may seem difficult to understand how heat can be transferred from a comparatively cooler vehicle passenger compartment to the hot outside air. The answer lies in the difference between the refrigerant pressure that exists in the evaporator and the pressure that exists in the condenser. In the evaporator, the compressor suction reduces the pressure and the boiling point below the temperature of the passenger compartment. Thus heat transfers from the passenger compartment to the boiling refrigerant. In the condenser, the compressor raises the condensation point above the temperature of the outside air. Thus the heat transfers from the condensing refrigerant to the outside air. The fixed orifice tube and the compressor simply create pressure conditions that permit the laws of nature to function.

AUTOMOTIVE COMPRESSORS

There are three basic types of air-conditioning compressors in general use in automotive applications. Each of these uses a reciprocating (back-and-forth motion) piston arrangement—two-cylinder

reciprocating, swash plate, and scotch yoke. Most automotive compressors are semihermetic.

Two-cylinder compressors (fig. 7-36) usually contain two pistons in a parallel V-type configuration. The pistons are attached to a connecting rod, which is driven by the crankshaft. The crankshaft is connected to the compressor clutch assembly, which is driven by an engine belt. Reed valves generally are used to control the intake and exhaust of the refrigerant gas during the pumping operation. These compressors are usually constructed of die cast aluminum.

In the swash plate or "wobble plate" compressor (fig. 7-37), the piston motion is parallel to the

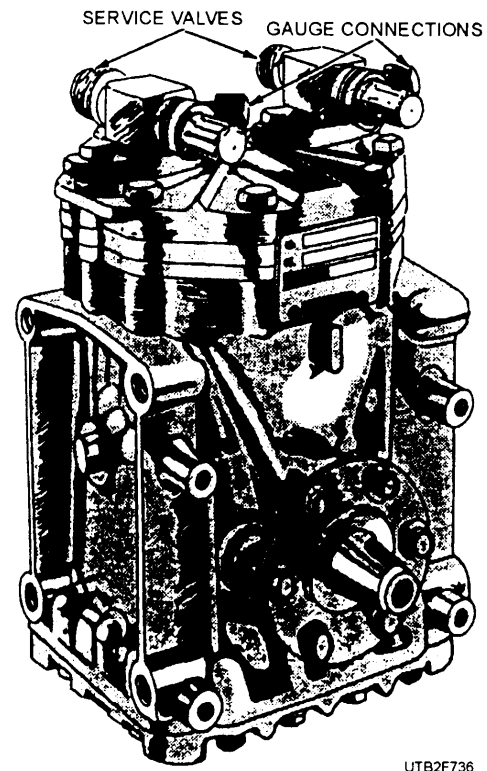

UTB2F736

Figure 7-36.—Two-cylinder reciprocating compressor.

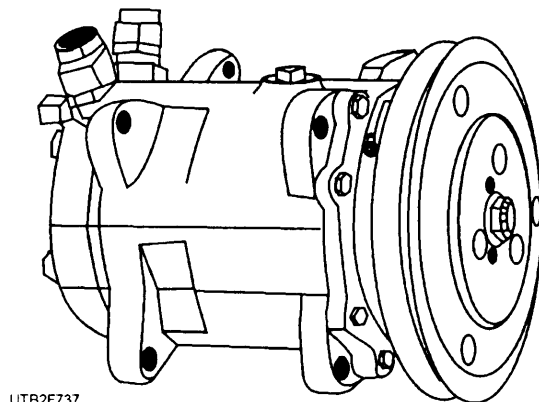

UTB2F737

Figure 7-37.—Five-cylinder swash plate compressor.

crankshaft. The pistons are connected to an angled swash plate using ball joints. Swash plate compressors are of three types—five-cylinder, six-cylinder, and five-cylinder variable.

The five- and six-cylinder swash compressor has, in effect, three cylinders at each end of its inner assembly. A swash plate of diagonal design is mounted on the compressor shaft. It actuates the pistons, forcing them to move back and forth in the cylinders as the shaft is rotated. Reed valves control suction and discharge; crossover passages feed refrigerant to both high- and low-service fittings at the rear end of the compressor. A gear type of oil pump in the rear head provides for compressor lubrication.

The five-cylinder variable swash plate compressor is different from the other swash plate compressors. It uses a plate connected to a hinge pin that permits the swash plate to change its angle. The angle of the swash plate is controlled by a bellows valve that senses suction pressure. During high load conditions the swash plate angle is large, and during low load conditions, the swash plate is smaller. The displacement of the compressor is high at a large angle and low at a small angle.

A scotch-yoke compressor changes rotary motion into reciprocating motion. The basic mechanism of the scotch yoke contains four pistons mounted 90 degrees from each other. Opposed pistons are pressed into a yoke that rides on a slide block located on the shaft eccentric (fig. 7-38). Rotation of the shaft provides a reciprocating motion with no connecting rods. Refrigerant flows into the crankcase through the rear and is drained through the reeds attached to the piston tops during the suction stroke. Refrigerant is then discharged through the valve plate out the connector block at the rear. These compressors are shorter in length and larger in diameter than other compressors.

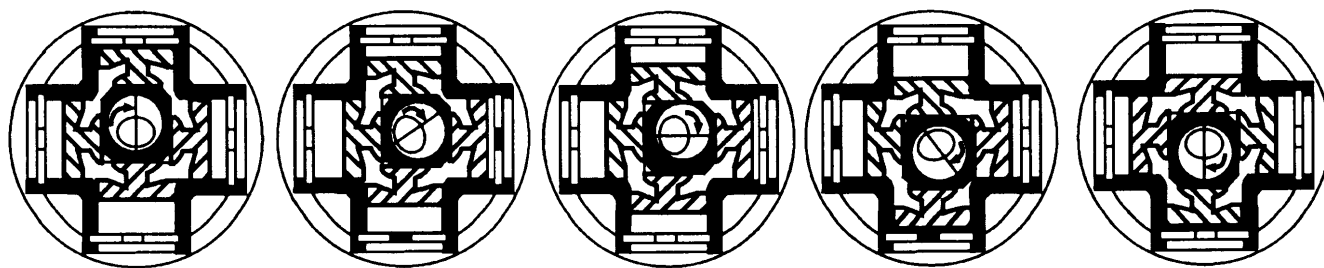

Figure 7-38.—Four-cylinder scotch-yoke mechanism.

Compressor Service Valves

Compressor service valves are built into some systems. They serve as a point of attachment for test gauges or servicing hoses. The service valves have three position controls—front seated, back seated, and midposition (fig. 7-39).

The position of this double-faced valve is controlled by rotating the valve stem with a service valve wrench. Clockwise rotation seats the front face of the valve and shuts off all refrigerant flow in the system. This position isolates the compressor from the rest of the system.

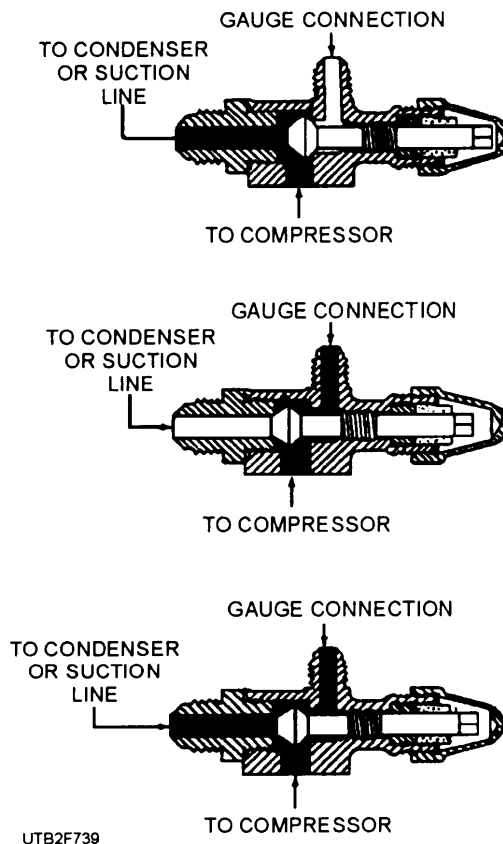

Figure 7-39.—Three-way service valve positions.

Counterclockwise rotation unseats the valve and opens the system to refrigerant flow (midposition). Systematic checks are performed with a manifold gauge set with the service valve in midposition. Further counterclockwise rotation of the valve stem seats the rear face of the valve. This position opens the system to the flow of refrigerant but shuts off refrigerant to the test connector. The service valves are used for observing of operating pressures; isolating the compressor for repair or replacement; and discharging, evacuating, and charging the system.

Compressors used in automotive air-conditioning systems generally are equipped with an electromagnetic clutch that energizes and de-energizes to engage and disengage the compressor. Two types of clutches are in general use—the rotating coil and the stationary coil.

The rotating coil clutch has a magnetic coil mounted in the pulley that rotates with the pulley. It operates electrically through connections to a stationary brush assembly and rotating slip rings. The clutch permits the compressor to engage or disengage as required for adequate air conditioning. The stationary coil clutch has the magnetic coil mounted on the end of the compressor. Electrical connections are made directly to the coil leads.

The belt-driven pulley is always in rotation while the engine is running. The compressor is in rotation and operation only when the clutch engages it to the pulley.

Air-conditioning and refrigeration systems use various control devices, including those for the refrigerant, the capillary tube usually found on window units, the automatic expansion valves also found on window units and small package units, the thermal expansion valve, and various types of suction pressure-regulating valves and devices. A brief description of a suction pressure-regulating valve is given below. A suction pressure-regulating valve is used on automotive air conditioning because the varying rpm of the compressor unit must maintain a constant pressure in the evaporator.

Suction Pressure-Regulating Valves

Suction pressure-regulating valves may be installed in the suction line at the outlet of the evaporator when a minimum temperature must be maintained. Suction pressure-regulating valves decrease the temperature difference, which would otherwise exist between the compartment temperature

and the surface of the cooling coils. The amount of heat that can be transferred into the evaporating refrigerant is directly proportional to the temperature difference. Figure 7-40 shows an exploded view of a typical suction pressure-regulating valve, sometimes called a suction throttling valve in automotive air conditioners.

Three types of suction pressure-regulating valves are used—suction throttling valve (STV), evaporator pressure regulators (EPR), or pilot-operated absolute valve (POA), developed by General Motors Corporation. These valves, in most cases, are adjustable.

The POA valve uses a sealed pressure element that maintains a constant pressure independent of the altitude of the vehicle. There are two basic types of metering devices built into a single container—the VIR (Valves-In-Receiver) and the EEVIR (Evaporator Equalized Valves-In-Receiver). These units combine the POA valve, receiver-drier, thermostatic expansion valve, and sight glass into a single unit.

The VIR assembly is mounted next to the evaporator, which eliminates the need for an external equalizer line between the thermostatic expansion valve and the outlet of the POA valve. The equalizer function is carried out by a drilled hole (equalizer port) between the two-valve cavities in the VIR housing.

The thermostatic expansion valve is also eliminated. The diaphragm of the VIR expansion valve is exposed to the refrigerant vapor entering the VIR unit from the outlet of the evaporator. The sight glass is in the valve housing at the inlet end of the thermostatic valve cavity where it gives a liquid indication of the refrigerant level.

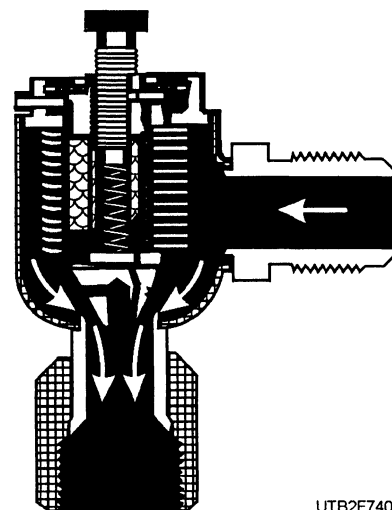

Figure 7-40.—A typical suction pressure-regulating valve.

The VIR thermostatic expansion valve controls the flow of refrigerant to the evaporator by sensing the temperature and pressure of the refrigerant gas, as it passes through the VIR unit on its way to the compressor. The POA valve controls the flow of refrigerant from the evaporator to maintain a constant evaporator pressure of 30 psi. The VIR and the POA valves are capsule type of valves. When found to be defective, you must replace the complete valve capsule.

The drier desiccant is in a bag in the receiver shell. It is replaceable by removing the shell and removing the old bag and installing a new bag of desiccant.

Service procedures for the VIR system differ in some respect from the service procedures performed on conventional automotive air-conditioning systems.

SERVICE PRECAUTIONS

Observe the following precautions whenever you are tasked to service air-conditioning equipment:

- Never open or loosen a connection before discharging the system.
- A system that has been opened to replace a component or one which has discharged through leakage must be evacuated before charging.
- Immediately after disconnecting a component from the system, seal the open fittings with a cap or plug.
- Before disconnecting a component from the system, clean the outside of the fittings thoroughly.
- Do not remove the sealing caps from a replacement component until you are ready to install it.
- Refrigerant oil absorbs moisture from the atmosphere if it is left uncapped. Do not open an oil container until it is ready to use, and install the cap immediately after using. Store the oil only in a clean, moisture-free container.
- Before connecting to an open fitting, always install a new seal ring. Coat the fitting and seal with the refrigerant oil before connecting.
- When installing a refrigerant line, avoid sharp bends. Position the line away from the exhaust or any sharp edges that may chafe the line.
- Tighten the fittings only to specified torque. The copper and aluminum fittings that are used in

refrigerant systems will not tolerate over-tightening.

- When disconnecting a fitting, use a wrench on both halves of the fitting to prevent twisting of refrigerant lines or tubes.
- Do not open a refrigerant system or uncap a replacement component unless it is as close as possible to room temperature. This prevents condensation from forming inside a component that is cooler than the surrounding air.
- Keep the service tools and work area clean. Contamination of a refrigerant system through careless work habits must be avoided.

DIAGNOSIS, TESTING, AND SERVICING

Diagnosis is more than just following a series of interrelated steps to find the solution to a specific condition. It is a way of looking at systems that are not functioning the way they should and finding out why. Also, it is knowing how the system should work and whether it is working correctly. All good diagnosticians use the same basic procedures.

There are basic rules for diagnosis. If these rules are followed, the cause of the condition will usually be found the first time through the system.

1. Know the system; know how the parts go together. Also, know how the system operates and its limits, and what happens when something goes wrong. Sometimes this means comparing a system that is working properly with the one you are servicing.

2. Know the history of the system. How old or new is the system? What kind of treatment has it had? Has it been serviced in the past in such a manner that might relate to the present condition? What is the service history? A clue in any of these areas might save a lot of diagnosis time.

3. Know the probability of certain conditions developing. It is true that most conditions are caused by simple things, rather than by complex ones, and they occur in a fairly predictable pattern. Electrical problem conditions, for instance, usually occur at connections, rather than in components. An engine "no-start" is more likely to be caused by a loose wire or some component out of adjustment than a sheared off camshaft. Know the difference between impossible and improbable. Many good technicians have spent hours diagnosing a system because they thought certain failures were "impossible," only to find out the failures

eventually were just "improbable" and actually had happened. Remember, new parts are just that—new. It does not mean they are good functioning parts.

4. Don't cure the symptom and leave the cause. Recharging a refrigerant system may correct the condition of insufficient cooling, but it does not correct the original problem unless a cause is found. A properly working system does not lose refrigerant over time.

5. Be sure the cause is found; do not be fooled into thinking the cause of the problem has been found. Perform the proper tests; then double-check the results. The system should have been checked for refrigerant leaks. If no leaks were found, perform a leak test with the system under extremely high pressure. If the system performed properly when new, it had to have a leak to be low in charge.

6. No matter what form charts may take, they are simply a way of expressing the relationship between the basic logic and a physical system of components. It is a way of determining the cause of a condition in the shortest possible amount of time. Diagnosis charts combine many areas of diagnosis into one visual display that allows you to determine the following:

- The probability of certain things occurring in a system
- The speed of checking certain components, or functions, before others
- The simplicity of performing certain tests before others
- The elimination of checking huge sections of a system by performing simple tests
- The certainties of narrowing down the search to a small area before performing in-depth testing

The fastest way to find a condition is to work with the tools that are available, which means working with proven diagnosis charts and the proper special tools for the system being worked on.

Service procedures for automotive air-conditioning units are similar to those used to service conventional air-conditioning systems. Discharging, evacuating, charging procedures, connections, and positions of valves on the gauge manifold set are shown in figure 7-41.

Service procedures for the VIR system are also similar to those used when servicing conventional air-conditioning systems. However, the hookup of the manifold gauge set is to the VIR unit. The

high-pressure fitting is located in the VIR inlet line. The low-pressure fitting is located in the VIR unit.

SYSTEM VISUAL INSPECTION

It is often possible to detect a problem caused by a careful visual inspection of the air-conditioning refrigerant system. This includes broken belts, obstructed condenser air passages, a loose clutch, loose or broken mounting brackets, disconnected or broken wires, and refrigerant leaks.

A refrigerant leak usually appears as an oily residue at the leakage point in the system. The oily residue soon picks up dust or dirt particles from the surrounding air and appears greasy. Through time, this builds up and appears to be heavy, dirt-impregnated grease.

Most common leaks are caused by damaged or missing O-ring seals at various hose and component connections. When these O rings are replaced, the new O rings should be lubricated with refrigerant oil. Care should be taken to keep lint from shop towels or cloths from contaminating the internal surfaces of the connection. Leakage may occur at a spring lock coupling if the wrong O rings are used at the coupling.

Another type of leak may appear at the internal Schrader type of air-conditioning charging valve core in the service gauge port valve fittings. If tightening the valve core does not stop the leak, it should be replaced with a new air-conditioning charging valve core.

Missing service gauge port valve caps can also cause a refrigerant leak. If this important primary seal (the valve cap) is missing, dirt enters the area of the air-conditioning charging valve core. When the service hose is attached, the valve depressor in the end of the service hose forces the dirt into the valve seat area, and it destroys the sealing surface of the air-conditioning charging valve core. When a service gauge port valve cap is missing, the protected area of the air-conditioning charging valve core should be cleaned and a new service gauge port valve cap should be installed.

CAUTION

The service gauge port valve cap must be installed finger tight. If tightened with pliers, the sealing surface of the service gauge port valve may be damaged.

TO OBSERVE OPERATING PRESSURES:
 VALVE A- CLOSED
 VALVE B- CLOSED
 VALVE C- BACK SEAT CRACKED OPEN
 VALVE D- BACK SEAT CRACKED OPEN

TO CHARGE REFRIGERANT THROUGH COMPRESSOR:
 CONNECT REFRIGERANT TANK TO E
 VALVE A-OPEN
 VALVE B-CLOSED
 VALVE C-BACK SEAT CRACKED OPEN
 VALVE D-BACK SEAT CRACKED OPEN

TO PURGE RECEIVER
 CONNECT PURGE LINE TO E
 VALVE A-CLOSED
 VALVE B-OPEN
 VALVE C-BACK SEAT CRACKED OPEN

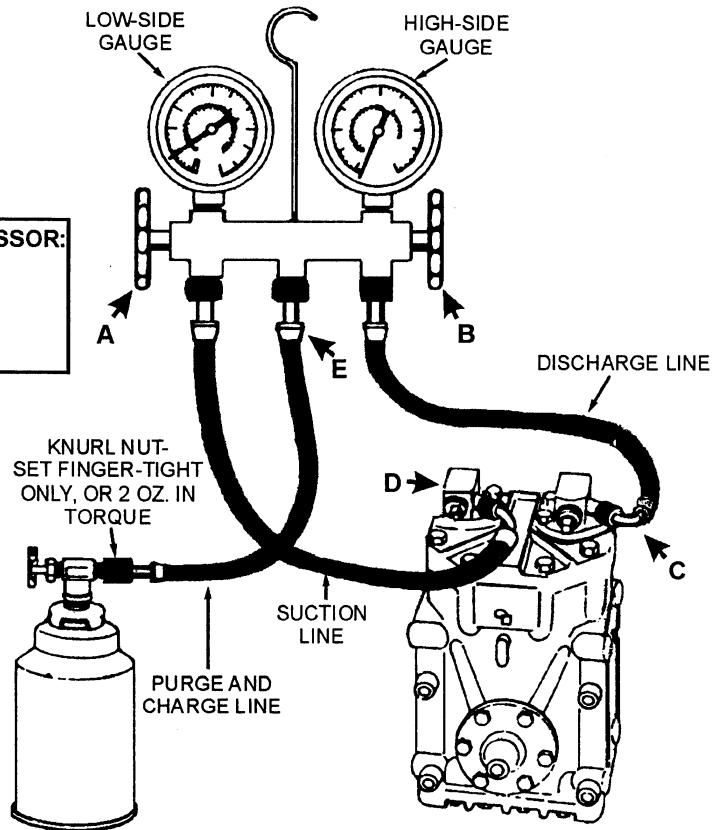

TO EVACUATE (REMOVE AIR) FROM SYSTEM
 VALVE A-OPEN...VALVE B-CLOSED...VALVE C-OPEN, BACK-SEATED...
 VALVE D-MID POSITION
 CONNECT HOSES: (1) FROM VALVE A TO VALVE D, (2) FROM VALVE B TO VALVE C, (3) FROM E TO VACUUM PUMP.
 PUMP VACUUM, CLOSE VALVE A. REMOVE HOSE FROM VACUUM PUMP AND ATTACH TO REFRIGERANT TANK.
 OPEN VALVE A. OPEN REFRIGERANT TANK TO BREAK VACUUM, AND USE STEP 2 FOR CHARGING SYSTEM.

NOTE: CHECK EQUIPMENT MANUFACTURERS CATALOG FOR INSTRUCTION SHEET FOR SPECIFIC RECOMMENDATIONS ON REFRIGERANT CHARGE, OIL CHARGE, AND SERVICE PROCEDURES FOR ANY PARTICULAR PIECE OF EQUIPMENT

UTB2F741

Figure 7-41.—Procedures for observing operating pressures, charging, purging, and evacuating a unit.

CLEANING A BADLY CONTAMINATED REFRIGERANT SYSTEM

A refrigerant system can become badly contaminated for a number of reasons.

- The compressor may have failed due to damage or wear.
- The compressor may have been run for some time with a severe leak or an opening in the system.
- The system may have been damaged by a collision and left open for some time.
- The system may not have been cleaned properly after a previous failure.

- The system may have been operated for a time with water or moisture in it.

A badly contaminated system contains water, carbon, and other decomposition products. When such a condition exists, the system must be flushed with a special flushing agent, using equipment designed especially for this purpose. Follow the suggestions and procedures outlined for proper cleaning.

Flushing Agents

A refrigerant to be suitable as a flushing agent must remain in the liquid state during the flushing operation to wash the inside surfaces of the system components. Refrigerant vapor will not remove

contaminant particles. They must be flushed with a liquid. Some refrigerants are better suited for this purpose than others.

R-11 and R-113 are suited for use with special flushing equipment. Both have rather high vaporization points—74.7°F for R-11 and 117.6°F for R-113. Both refrigerants also have low closed container pressures. This reduces the danger of an accidental system discharge to a ruptured hose or fitting. R-113 will do the best job and is recommended as a flushing refrigerant. Both R-11 and R-113 require a propellant or a pump type of flushing equipment due to their low closed container pressures. R-11 is available in pressurized containers. Although not recommended for regular use, it may become necessary to use R-11 if special flushing equipment is not available. It is more toxic than other refrigerants, and it should be handled with extra care. Currently new refrigerants are being developed to replace R-11 and R-113 because these refrigerants will be phased out by the year 2000.

CAUTION

Use extreme care and adhere to all safety precautions related to the use of refrigerants when flushing a system.

System Cleaning and Flushing

When it is necessary to flush a refrigerant system, the suction accumulator/drier must be removed and replaced, as it is impossible to clean. Remove the fixed orifice tube. If a new tube is available, replace the contaminated one; otherwise, wash it carefully in flushing refrigerant or mineral spirits and blow it dry. If it does not show signs of damage or deterioration, it may be reused. Install new O rings.

Any moisture in the evaporator will be removed during leak testing and system evacuation following the cleaning job. Perform each step of the cleaning procedure carefully as outlined below.

1. Check the hose connections at the flushing cylinder outlet and flushing nozzle to ensure they are secure.

2. Ensure the flushing cylinder is filled with approximately 1 pint of R-113 and that the valve assembly on top of the cylinder is tightened securely.

3. Connect a can of R-12 or R-134a to the Schrader valve at the top of the charging cylinder. A

refrigerant hose and a special, safety type of refrigerant dispensing valve are required for connecting the small can to the cylinder. Ensure all connections are secure.

4. Connect a gauge manifold and a discharge system. Disconnect the gauge manifold.

5. Remove and discard the suction accumulator/drier. Install a new accumulator/drier and connect it to the evaporator. Do not connect it to the suction line from the compressor. Ensure a protective cap is in place on the suction line connection.

6. Replace the fixed orifice tube. Install a protective cap on the evaporator inlet tube as soon as the new orifice tube is in place. The liquid line will be connected later.

7. Remove the compressor from the vehicle for cleaning and servicing or replacement, whichever is required. If the compressor is cleaned and serviced, add the specified amount of refrigerant oil before installing it on the mounting brackets in the vehicle. Install the shipping caps on the compressor connections. Install a new compressor on the mounting brackets in the vehicle.

8. Back flush the condenser and the liquid line as follows:

- a. Remove two O rings from the condenser inlet tube spring lock coupling.

- b. Remove the discharge hose from the condenser and clamp a piece of (1/2-inch ID) heater hose to the condenser inlet line. Ensure the hose is long enough to insert the free end into a suitable waste container to catch the flushing refrigerant.

- c. Move the flushing equipment into position and open the valve on the can of R-12 or R-134a (fully counterclockwise).

- d. Back flush the condenser and the liquid line by introducing flushing refrigerant into the supported end of the liquid line with the flushing nozzle. Hold the nozzle firmly against the open end of the liquid line.

- e. After the liquid line and condenser have been flushed, lay the charging cylinder on its side so R-12 or R-134a will not force more of the flushing refrigerant into the liquid line. Press the nozzle firmly to the liquid line and admit the R-12 or R-134a to force all of the flushing refrigerant from the liquid line and condenser.

- f. Remove the 1/2-inch hose and clamp from the condenser inlet connection.

g. Stand the flushing cylinder upright and flush the compressor discharge hose. Secure it so the flushing refrigerant goes into the waste container.

h. Close the dispensing valve of the R-12 or R-134a can (fully clockwise). If there is any flushing refrigerant in the cylinder, it may be left there until the next flushing job. Put the flushing kit and R-12 or R-134a can in a suitable storage location.

i. Install the new lubricated O rings on the spring lock coupling male fittings on both the condenser inlet and the liquid lines. Assemble the couplings.

9. Connect all refrigerant lines. All connections should be cleaned and new O rings should be used. Lubricate new O rings with clean refrigerant oil.

10. Connect a charging station or manifold gauge set and charge the system with 1 pound of R-12 or R-134a. (Do not evacuate the system until after it has been leak tested.)

11. Leak test all connections and components with a flame type of leak detector or an electronic leak detector. If no leaks are found, go to Step 12. If leaks are found, service as necessary; check the system and then go to Step 12.

12. Evacuate and charge the system with a specified amount of R-12 or R-134a. Operate the system to ensure it is cooling properly.

SAFETY PRECAUTIONS

The use of safety when handling or using refrigerants can never be stressed enough. As discussed in chapter 6 of this TRAMAN, routinely think of safety for yourself and coworkers.

Extreme care must be taken to prevent any liquid refrigerant from coming in contact with the skin and especially the eyes. A bottle of sterile mineral oil and a quantity of weak boric acid solution must always be kept nearby when servicing the air-conditioning system. Should any liquid refrigerant get into your eyes, immediately use a few drops of mineral oil to wash them out; then wash the eyes clean with the weak boric acid solution. Seek a doctor's aid immediately even though irritation may have ceased. Always wear safety goggles when servicing any part of the refrigerant system.

To avoid a dangerous explosion, never weld, solder, steam clean, bake body finishes, or use any excessive amount of heat on or in the immediate area of

any part of the refrigerant system or refrigerant supply tank, while they are closed to the atmosphere whether filled with refrigerant or not.

The liquid refrigerant evaporates so rapidly that the resulting refrigerant gas displaces the air surrounding the area where the refrigerant is released. To prevent possible suffocation in enclosed areas, always discharge the refrigerant into recycling/reclaiming equipment. Always maintain good ventilation surrounding the work area.

Although R-12 gas, under normal conditions, is nonpoisonous, the discharge of refrigerant gas near an open flame can produce a very poisonous gas. This gas also attacks all bright metal surfaces. This poisonous gas is generated when the flame type of leak detector is used. Avoid inhaling the fumes from the leak detector. Ensure that R-12 is both stored and installed according to all federal, state and local ordinances.

When admitting R-12 or R-134a gas into the cooling unit, always keep the tank in an upright position. If the tank is on its side or upside down, liquid R-12 or R-134 enters the system and may damage the compressor.

TRUCK AND BUS AIR CONDITIONING

The cabs of many truck-tractors and long distance hauling trucks and earthmover cabs are air-conditioned. Most of this equipment is of the "hang on" type and is installed after the cab has been made.

Some truck air-conditioning units have two evaporators—one for the cab and one for the relief driver's quarters in back of the driver. Some systems use a remote condenser, mounted on the roof of the cab. This type of installation removes the condenser from in front of the radiator, so the radiator can operate at full efficiency. This is especially important during long pulls in low gear.

The system is similar to the automobile air conditioner and is installed and serviced in the same general way.

The air conditioning of buses has progressed rapidly. Because of the large size of the unit, most bus air-conditioning systems use a separate gasoline engine with an automatic starting device to drive the compressor. The system is standard in construction except for the condensing unit. It is made as compact as possible and generally is installed in the bus, so it can be easily reached for servicing.

Condensing units are often mounted on rails with flexible suction and liquid lines to permit sliding the condensing unit out of the bus body to aid in servicing.

Air-cooled condensers are used. Thermostatic expansion valve refrigerant controls are standard. Finned blower evaporators are also used.

The duct system usually runs between a false ceiling and the roof of the bus. The ducts, usually one on each side of the bus, have grilles at the passenger seats. The passengers may control the grille by opening and closing.

CERTIFICATION

The Environmental Protection Agency (EPA) has established as per the Clean Air Act (CAA) that all technicians who maintain or repair air-conditioning or refrigeration equipment or technicians who operate recycling, reclaiming, and recovery equipment must be certified. Certification is administered by organizations with certification programs that are approved by the EPA. It is important to understand, that as a Utilitiesman, if you are not certified, you cannot do any HVAC/R service that requires use or removal of refrigerants. Certification requirements are divided into two different areas—automotive air-conditioning and HVAC/R.

Automotive Air-Conditioning Certification

Automotive air conditioning is serviced or repaired more often than other types of air-conditioning systems. In today's world, automotive air-conditioning systems are heavily used as our society spends more and more time in their vehicles. Industry experts say that 25 percent of the R-12 purchased in the United States is used in automotive air conditioning. The fittings and hoses used in automotive air conditioning allow leakage to occur. Automotive air-conditioning service facilities or technicians are now changing (retrofitting) systems in vehicles to use refrigerant R-134a and removing CFC R-12 to meet new standards. From the EPA's standpoint, technicians must meet the following requirements to be certified:

- Be aware that venting refrigerant is illegal.
- Understand why all the regulations are being created. Understand what is happening to the environment.
- Have a working knowledge of SAE standards J-1989, J-1990, and J-1991.

- Perform service in a safe manner without injuring personnel or damaging equipment. Areas that must be understood include venting, handling, transporting, and disposing of refrigerant.

Once these requirements are met through testing of the individual applicant, a certification card is issued.

Heating, Ventilating, Air Conditioning, and Refrigeration Certification

Certification requirements to service standard types of air-conditioning systems are the same as for automotive air-conditioning certification. Unlike the automotive certification program, standard air-conditioning certification is divided into levels corresponding to the type of service the technician performs. There are four types of certification:

- Type I – Servicing small appliances
- Type II – Servicing high or very high-pressure appliances
- Type III – Servicing or disposing of low-pressure appliances
- Type IV (Universal) – Servicing all types of equipment

Individuals will be required to take a proctored, closed book test. These tests are offered by organizations approved by the EPA for the specific type of certification that the individual technician requires. Technicians can only work on air-conditioning systems that they have been certified for service.

Q33. The saturation temperature increases or decreases depending upon what factor?

Q34. What are the three basic types of automotive compressors?

Q35. A scotch-yoke compressor changes rotary motion into what type of motion?

Q36. Refrigerant can be put into a system when the service valve is back-seated. True /False

Q37. The POA valve, receiver-drier, expansion valve, and sight glass are combined in what type of device?

Q38. Service procedures for VIR systems are different than conventional automotive air-conditioning systems. True/False

- Q39. *What is the most important thing you should know before you perform a diagnosis on a system problem?*
- Q40. *A refrigerant leak appears in what way at the point of the leak?*
- Q41. *What is the most common cause of leaks on automotive air-conditioning systems?*
- Q42. *For a refrigerant to be a suitable flushing agent, it must remain in what state during flushing operations?*
- Q43. *Which part of an automotive air-conditioning system is replaced because it is impossible to clean?*
- Q44. *A type IV certification is also known as what type of certification?*
- Q45. *Who approves organizations to certify technicians?*

DUCTWORK

Learning Objective: Understand the basic types of ductwork systems and the components of those systems for distribution of conditioned air.

Distributed air must be clean, provide the proper amount of ventilation, and absorb enough heat to cool the conditioned spaces. To deliver air to the conditioned space, air carriers are required, which are called ducts. Ducts work on the principle of air pressure difference. If a pressure difference exists, air will flow from an area of high pressure to an area of low pressure. The larger this difference, the faster the air will flow to the low-pressure area.

CLASSIFICATION OF DUCTS

There are three common classifications of ducts—conditioned air ducts, recirculating-air ducts, and fresh-air ducts. Conditioned air ducts carry conditioned air from the air conditioner and distribute it to the conditioned area. Recirculating air ducts take air from the conditioned space and distribute it back into the air conditioner system. Fresh air ducts bring fresh air into the air-conditioning system from outside the conditioned space.

Ducts commonly used for carrying air are of a round, square, or rectangular shape. The most efficient

duct is a round duct, based on the volume of air handled per perimeter distance. In other words, less material is needed for the same capacity as a square or rectangular duct.

Square or rectangular duct fits better to building construction. It fits above ceilings and into walls and is much easier to install between joists and studs.

TYPES OF DUCT SYSTEMS

There are several types of supply duct systems (fig. 7-42) that deliver air to room(s) and then return the air from the room(s) to the cooling (evaporator) system. These supply systems can be grouped into four types:

1. Individual round pipe system
2. Extended plenum system
3. Reducing trunk system
4. Combination (of two or more systems)

Return air systems are normally of three types—single return, multiple return (fig. 7-42), or combination of the two systems.

CONSTRUCTION

Ducts may be made of metal, wood, ceramic, and plastic. Most commonly used is sheet steel coated with zinc (galvanized steel). Sheet metal brakes and forming machines are used in fabricating ducts. Elbows and other connections, such as branches, are designed using geometric principles. Some types of duct connections used in constructing duct systems are shown in figure 7-43.

Sheet metal ducts expand and contract as they heat and cool. Fabric joints are often used to absorb this movement. Fabric joints should also be used where the duct connects to the air conditioner. Many ducts are insulated to lower noise and reduce heat transfer. The insulation can be on the inside or the outside of the duct. Adhesives or metal clips are commonly used to fasten the insulation to the duct. As we are only briefly discussing construction here, you can find construction and fabrication methods in the *Steelworker*, volume 2. It details design and fabrication of steel ductwork.

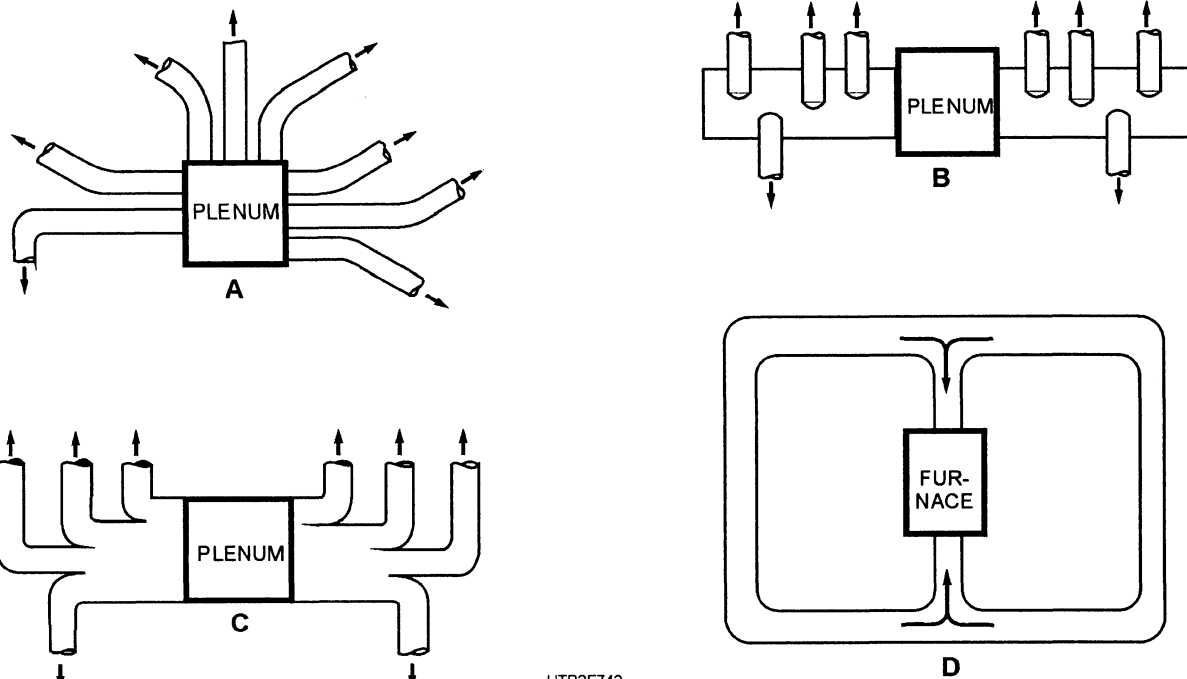

UTB2F742

Figure 7-42.—Supply duct systems: A. Individual round pipe; B. Extended plenum; C. Reducing trunk; D. Multiple return air system.

COMPONENTS

To enable a duct system to circulate air at the proper velocity and volume to the proper conditioned areas, you can use different components within the duct system, such as diffusers, grilles, and dampers.

Diffusers, Grilles, and Registers

Room openings to ducts have several devices that control the airflow and keep large objects out of the duct. These devices are called diffusers, grilles, and registers. Diffusers deliver fan-shaped airflow into a room. Duct air mixes with some room air in certain types of diffusers.

Grilles control the distance, height, spread of air-throw, and amount of air. Grilles cause some resistance to airflow. Grille cross-section pieces block about 30 percent of the air. Because of this reason and to reduce noise, cross sections are usually enlarged at the grille. Grilles have many different designs, such as fixed vanes which force air in one direction, or adjustable to force air in different directions.

Registers are used to deliver a concentrated air stream into a room, and many have one-way or two-way adjustable air stream deflectors.

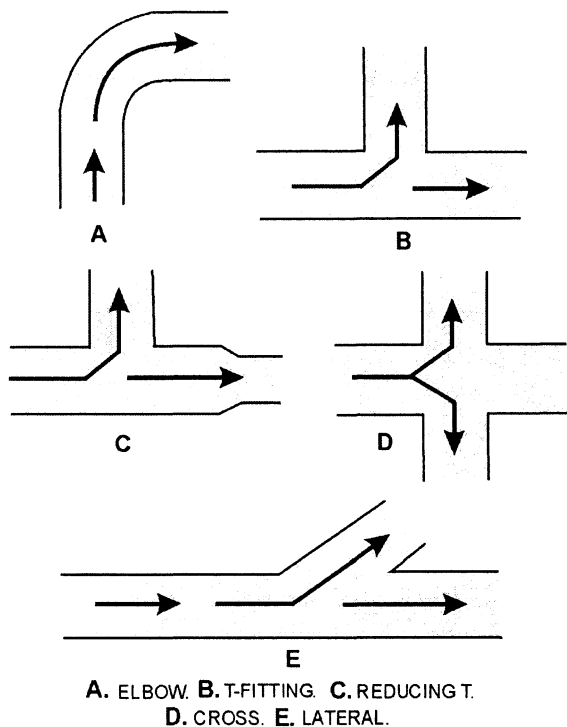

UTB2F743

Figure 7-43.—Typical duct connections: A. Elbow; B. Tee; C. Reducing tee; D. Cross; E. Lateral.

The axial-flow fan is usually direct-driven by mounting the fan blades on the motor shaft. The radial-flow fan is normally belt-driven but can also be direct-driven.

BALANCING THE SYSTEM

Balancing a system basically means sizing the ducts and adjusting the dampers to ensure each room receives the correct amount of air. To balance a system, follow these steps:

1. Inspect the complete system; locate all ducts, openings, and dampers.
2. Open all dampers in the ducts and at the grilles.
3. Check the velocities at each outlet.
4. Measure the "free" grille area.
5. Calculate the volume at each outlet. $\text{Velocity} \times \text{Area} = \text{Volume}$
6. Area in square inches divided by 144 multiplied by feet per minute equals cubic feet/minute.
7. Total the cubic feet/minute.

8. Determine the floor areas of each room. Add to determine total area.

9. Determine the cfm for each room. The area of the room divided by the total floor area multiplied by the total cfm equals cfm for the room.

10. Adjust duct dampers and grille dampers to obtain these values.

11. Recheck all outlet grilles.

In some cases, it may be necessary to overcome excess duct resistance by installing an air duct booster. These are fans used to increase airflow when a duct is too small, too long, or has too many elbows.

Q46. What are the three common types of ducts?

Q47. What are the three types of return air systems?

Q48. Sheet metal ducts expand and contract as they heat and cool. True /False

Q49. What are the three types of dampers?

Q50. Once you have checked the velocities at each outlet, what is the next step when balancing the duct system?