



PDHonline Course M564 (10 PDH)

Welding Technology - Quiz Questions – Terms and Definitions

Instructor: Jurandir Primo, PE

2020

PDH Online | PDH Center

5272 Meadow Estates Drive
Fairfax, VA 22030-6658
Phone: 703-988-0088
www.PDHonline.com

An Approved Continuing Education Provider

**WELDING TECHNOLOGY - QUIZ QUESTIONS
TERMS & DEFINITIONS**

CONTENTS:

	Page
I. INTRODUCTION	2
II. WELDING INSPECTOR CERTIFICATIONS	3
III. NDT CERTIFICATIONS	4
IV. WELDING TERMS AND DEFINITIONS	6
V. WELDING TECHNOLOGY – QUIZ QUESTIONS	80
➤ Module 1: Qualification, Inspection and Certification	80
➤ Module 2: Safety in Welding	87
➤ Module 3: Welding Processes, Cutting and Inspection Knowledge	89
➤ Module 4: Welding Metallurgy, NDT and Destructive Testing	104

I. INTRODUCTION:

Quiz questions are, undoubtedly, the best way to learn the concepts and definitions and to pass a test in any specific area. These quiz questions are based totally in several welding training courses and brought here to help the students interested in advanced learning, even for specific areas. These questions are commonly used on applicants to a job, operations, maintenance and in inspection, as part of the global industry businesses. The answers are presented at the end of the quiz questions.

A glossary, also known as a vocabulary, or *clavis*, is also presented with an alphabetical list of terms, considering the definitions for the most usual welding technology terms. Traditionally, a glossary appears at the end of a book and includes terms within that book, however, in this handbook the glossary is presented before each sector of the welding quiz questions, to show a guideline to students, that enables definition of major concepts, especially for newcomers to this field of study.

The welding industry is broad and includes people who carry the job title of "welders", and others like pipe-fitters, boilermakers and iron-workers, who may weld, but only for a part of their day on the job. Beyond these skilled positions, there are technicians, inspectors, supervisors, managers and engineers, all involved with welding subjects, in some way or the other. The American Welding Society (AWS) are always credentialing professionals for all of these areas, from simple and informal inside companies' trades, to nationally and internationally recognized programs.

Testing in the welding industry is focused on the type of work being done. In some cases, typically for the more basic level positions, there may be only a practical demonstration required. In other cases, a welding test may include a code or a practical hands-on including the fundamentals of the welding section in a written form, using multiple-choice questions with a time limit to complete the test. Once a welder is certified, he or she receives a written document, known as Welder Qualification Test Record (WQTR), which explains the extent to which the welder can work.

Manufacturing, building structures, bridges, pressure vessels and storage tank codes require qualified welders and inspectors. Then, companies must require certification of their welders, not only as marketing tools, but to ensure customers that the work is getting done correctly by competent people. Today, certifications are very important to help a newcomer or a professional to get his foot in the industry door, at the interview stage. Properly qualified, one can rapidly advance through the ranks.

To get your Professional Development Hours, this course includes a multiple-choice quiz at the end, based on the glossaries and consecutively in all questions concepts, defined to enhance the understanding of the course materials.

PDHONLINE courses references:

- M381 - Welding Technology and Inspection Procedures – AWS D1.1
- M415 - Welding Inspection Qualifications & Testing Procedures
- M514 - Gas Metal Arc Welding - GMAW – Best Practices
- M544 - Underwater Welding Technology – Cutting & Inspection

II. WELDING INSPECTOR CERTIFICATIONS:

The most common AWS professional certifications are:

Certified Associate Welding Inspector (CAWI): To qualify as a Certified Associate Welding Inspector (CAWI), you must pass a vision test and have a combination of qualifying education and work experience, with supporting documentation.

Minimum Education	Work Experience
High school diploma or hold a state or military approved high school equivalency diploma (e.g. GED)	2 years
At least 8th grade	4 years
Less than 8th grade	6 years
At least 8th grade with a minimum of one year of vocational education and training in a welding curriculum	3 years
2 years post-high school education in a welding curriculum or engineering technology, engineering, or physical science	6 months

Certified Welding Inspector (CWI): To qualify as a Certified Welding Inspector (CWI), you must pass a vision test and have a combination of qualifying education and work experience, with supporting documentation:

Minimum Education	Work Experience
Associate or higher degree in engineering technology, engineering, or a physical science	3 years
High school diploma plus two or more years engineering/technical school courses	3 years
High school diploma plus one year engineering/technical school courses or one or more years of vocational education and training in a welding curriculum	4 years
High school diploma or approved high school equivalency diploma	5 years
At least 8th grade	9 years
Less than 8th grade	12 years

Senior Certified Welding Inspector (SCWI): Candidates typically will have supplemented their basic education or gained extensive problem-solving experience. This type of background generally provides them with a deeper and more specific understanding of advanced NDE topics, quality systems, procedure qualifications, and other SCWI knowledge areas as identified below:

- Must have a minimum of 15 years' work experience;
- Direct relationship to welded assemblies fabricated to national or international standards;
- Direct involvement in two or more areas of welding inspection capabilities;
- Design - preparation of plans and drawing for weldments, preparation of inspection procedures, requirements, acceptance criteria;
- Production - planning, control, and supervision of welding materials and operations;
- Quality Control - detection and measurement of weld discontinuities, procedures, supervision of personnel, specification of QC methods, review of QC programs of vendors;
- Examination - examination testing, visual or other nondestructive evaluation process;
- Repair of defective welds or supervision of personnel performing repair.

Other AWS Certifications: Certified Welding Educator; Certified Radiographic Interpreter; Certified Welding Supervisor; Certified Welding Sales Representative; Certified Welding Engineer; Certified Welder Certified Robotic Arc Welding.

Examination	Minimum no. of Questions	Duration	Minimum % to pass
Part A - Fundamentals (closed book test)	150	2 h	72%
Part B - Practical (hands on test)	46	2 h	72%
Part C - Code Book (open book test)	46-60	2 h	72%

* All Exam questions are multiple choices and objective types

Note: Effective March 16, 2015, all individuals who have applied for and are scheduled to test to the ASME Sec IX: B31.1 & B31.3 codebook exam (Part C of CWI exam or CWI endorsement exam) will be testing to the following editions; ASME Section IX: 2013; B31.1: 2014; B31.3: 2012.

Certification Scheme for Personnel (CSWIP): The scope of CSWIP includes, Welding Inspectors, Welding Supervisors, Welding Instructors, Welding Examiners, Welding Quality Control Coordinators, Heat Treatment Operatives, Cathodic Inspection personnel, Plant Inspectors, Underwater Inspectors, Plastics Welders and NDT personnel, in accordance with BS EN ISO/IEC 17024.

These certificates are normally accepted by all employers, though some European companies do not accept AWS-CWI and some American companies do not accept CSWIP certificates, but these companies are just few. The Welding Inspector’s Certificates offered by TWI-UK (www.twisea.com) are:

- 3.0 Visual Welding Inspector;
- 3.1 Welding Inspector;
- 3.2.1 Senior Welding Inspector) without radiographic interpretation;
- 3.2.2 Senior Welding Inspector with radiographic interpretation.

Obs.: Effective May 21, 2012, individuals holding CSWIP credentials must fill out all standard applications to register for CWI examinations, and must take and pass all three components of the CWI examination to earn CWI credentials.

III. NDT CERTIFICATION:

ASNT Certification: The ASNT NDT Level II certification program was developed to provide standard Level II written examinations to satisfy the general and specific examination guidelines of recommended Practice No. SNT-TC-1A.

General Examinations: There are 50 questions multiple-choice general examinations that cover the fundamentals, principles and theory found in the ANSI/ASNT American National Standard CP-105, ASNT Standard Topical Outlines for Qualification of Nondestructive Testing Personnel.

ASNT NDT Level II: Qualification Requirements. Candidate shall agree to abide by the ASNT Level II Code of Ethics and must document the combination of education and experience as shown below:

Examination Method	Training Hours	Experience	
		Hours in Method	Total Hours in NDT
Liquid Penetrant	12	210	400
Magnetic Particle	20	280	530
Radiographic	80	840	1600
Ultrasonic	80	840	1600
Visual	24	210	400

Specific Examinations: The specific examinations determine the industry Sector. ASNT currently offers Specific examinations for the General Inspection and Pressure Equipment Sectors. These examinations consist of 40 multiple-choice questions based on an NDT procedure covering the equipment, operating processes and NDT techniques commonly used in the applicable industry Sector.

Examination Times

Examination Type	Test Method				
	MT	PT	RT	UT	VT
General	2 hours	2 hours	2 hours	2 hours	2 hours
Specific	2 hours	2 hours	2 hours	2 hours	2 hours

The **ASNT NDT Level III** Program and the Industrial Radiography and Radiation Safety Personnel (IRRSP) program are accredited by ANSI to ISO/IEC 17024:2003. General requirements for bodies operating certification of persons. There are four ASNT certification programs:

[ASNT NDT Level III Program](#),
[ASNT Central Certification Program \(ACCP\)](#),
[ASNT NDT Level II program](#), and
[Industrial Radiography and Radiation Safety Personnel \(IRRSP\) program](#).

Basic and Method Exams: ASNT NDT Level III certification candidates are required to pass both the NDT Basic and a method examination in order to receive the ASNT NDT Level III certificate. For the full topical outlines and complete list of references, see the topical outlines listed in the American National Standard *ANSI/ASNT CP-105, Standard Topical Outlines for Qualification of Nondestructive Testing Personnel*.

IV. WELDING TERMS AND DEFINITIONS:

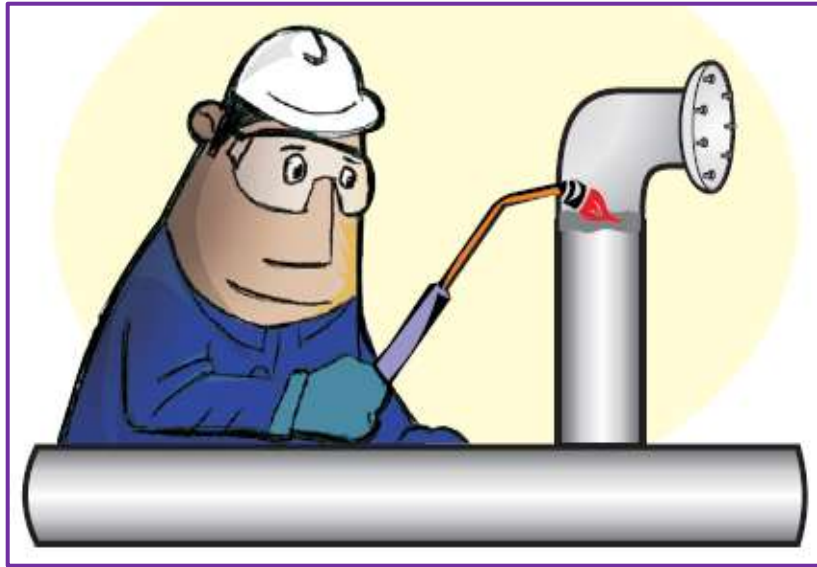

Welding Positions Standards: Welding is usually easiest when the welder can work on a joint located on a flat, horizontal surface, such as on a table or bench. However, joints in the field may be located in a variety of positions relative to the welder and to the horizon. It is very important for a Welding Inspector to know the position, or location of a joint relative to the horizon, because it may determine what welding process, methods, and techniques are used.

1F, pipe. A welding test position designation for a circumferential fillet weld applied to a joint in pipe, with its axis approximately 45° from horizontal, in which the weld is made in the flat welding position by rotating the pipe about its axis. See figure below:

1F, plate. A welding test position designation for a linear fillet weld applied to a joint in which the weld is made in the flat welding position. See figure below:

1G, pipe. A welding test position designation for a circumferential groove weld applied to a joint in pipe, in which the weld is made in the flat welding position by rotating the pipe about its axis. See figure below:

1G, plate. A welding test position designation for a linear groove weld applied to a joint, in which the weld is made in the flat welding position. See figure below:

2F, pipe. A welding test position designation for a circumferential fillet weld applied to a joint in pipe, with its axis approximately vertical, in which the weld is made in the horizontal welding position. See figure below:

2F, plate. A welding test position designation for a linear fillet weld applied to a joint, in which the weld is made in the horizontal welding position. See figure below:

2FR, pipe. A welding test position designation for a circumferential fillet weld applied to a joint in pipe, with its axis approximately horizontal, in which the weld is made in the horizontal welding position by rotating the pipe about its axis. See figure below:

2G, pipe. A welding test position designation for a circumferential groove weld applied to a joint in a pipe, with its axis approximately vertical, in which the weld is made in the horizontal welding position. See figure below:

2G, plate. A welding test position designation for a linear groove weld applied to a joint in which the weld is made in the horizontal welding position. See figure below:

3F, plate. A welding test position designation for a linear fillet weld applied to a joint in which the weld is made in the vertical welding position. See figure below:

3G, plate. A welding test position designation for a linear groove weld applied to a joint in which the weld is made in the vertical welding position. See figure below:

4F, pipe. A welding test position designation for a circumferential fillet weld applied to a joint in pipe, with its axis vertical, in which the weld is made in the overhead welding position. See figure below:

4F, plate. A welding test position designation for a linear fillet weld applied to a joint, in which the weld is made in the overhead welding position. See figure below:

4G, plate. A welding test position designation for a linear groove weld applied to a joint in which the weld is made in the overhead welding position. See figure below:

5F, pipe. A welding test position designation for a circumferential fillet weld applied to a joint, in pipe, with its axis approximately horizontal, in which the weld is made in the horizontal, vertical, and overhead welding positions. The pipe remains fixed until the welding of the joint is complete. See figure below:













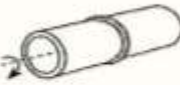







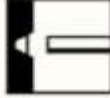

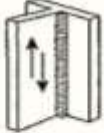
5G, pipe. A welding test position designation for a circumferential groove weld applied to a joint in a pipe with its axis horizontal, in which the weld is made in the flat, vertical, and overhead welding positions. The pipe remains fixed until the welding of the joint is complete. See figure below:

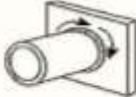
6F, pipe. A welding test position designation for a circumferential fillet weld applied to a joint in pipe, with its axis approximately 45° from horizontal, in which the weld is made in flat, vertical, and overhead welding positions. The pipe remains fixed until welding is complete. See figure below:

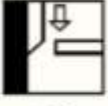
6G, pipe. A welding test position designation for a circumferential groove weld applied to a joint in pipe, with its axis approximately 45° from horizontal, in which the weld is made in the flat, vertical, and overhead welding positions. The pipe remains fixed until welding is complete. See figure below:

6GR, pipe. A welding test position designation for a circumferential groove weld applied to a joint in pipe, with its axis approximately 45° from horizontal, in which the weld is made in the flat, vertical, and

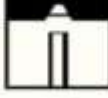
overhead welding positions. A restriction ring is added, adjacent to the joint, to restrict access to the weld. The pipe remains fixed until welding is complete. See figure below:

AWS according to ASME section IX EN according to ISO 6947, NEN-EN 287				Welding positions according to EN 26947	
 AWS: 1G EN: PA	 AWS: 1F EN: PA	 AWS: 1G EN: PA	 AWS: 2F EN: PB	 PA	 PB
 AWS: 2G EN: PC	 AWS: 2F EN: PB	 AWS: 2G EN: PC	 AWS: 2F EN: PB	 PC	 PB
 AWS: 3G EN: PG (down) PF (up)	 AWS: 3F EN: PG (down) PF (up)	 AWS: 5G EN: PG (down) PF (up)	 AWS: 5F EN: PG (down) PF (up)	 PF	 PG
 AWS: 4G EN: PE	 AWS: 4F EN: PD	 AWS: 6G EN: H-L045	 AWS: 4F EN: PD	 PE	 PD

Welding certifications come in many position depending on the type of structure that will be welded. Most codes allow a welder to take a combination of the 3 and 4G positions. However, fillet welds do not qualify the welder for groove welds. The code system in ASME IX QW-461.1 and QW-461.2 is:

- 1 - stands for the flat position (F)
- 2 - stands for the horizontal position (H)
- 3 - stands for the vertical position (V)
- 4 - stands for the overhead position (O)
- F - stands for a filler weld joint
- G - stands for a groove weld joint.

Pipe welding test positions have the same coding system as structural positions with one main exception, the "R" or restricted position, to make the test as difficult as possible to provide the same types of obstacles that the welder will encounter in the field. For example a 6GR test would be a pipe in the fixed 45° position with a restricted groove joint.

ISO and ASME welding positions

Butt welds in plate

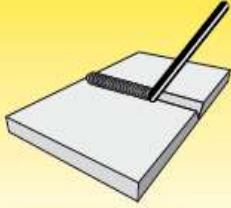

Downhand: PA/1G



Horizontal-vertical: PC/2G



Overhead: PE/4G

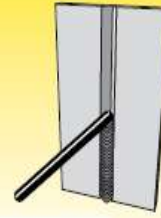

Vertical-up: PF/3G



Vertical-down: PG/3G

Fillet welds in plate



Downhand: PA/1F

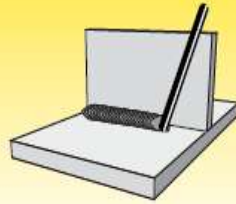

Horizontal: PB/2F

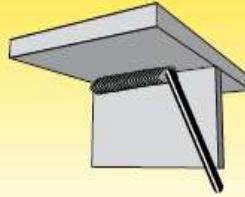

Overhead: PD/4F

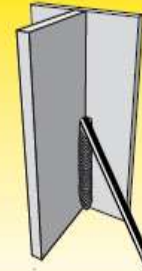

Vertical-up: PF/3F

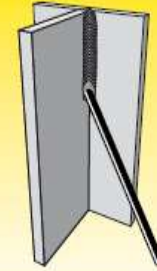

Vertical-down: PG/3F

Butt welds in pipe



Pipe rotates horizontal axis
Downhand: PA/1G

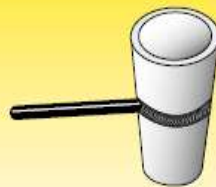

Pipe fixed vertical axis, welding
horizontal-vertical: PC/2G



Pipe fixed horizontal axis,
welding uphill: PH/5G



Pipe fixed horizontal axis,
welding downhill: PJ/5G

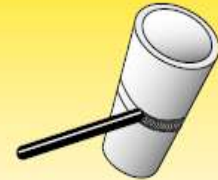

Pipe fixed with axis under 45°
welding uphill: H-LO45/6G

Fillet welds pipe to plate.

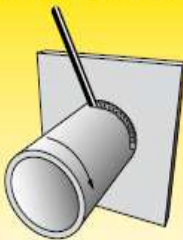

Pipe rotates horizontal axis
Downhand: PB/2FR

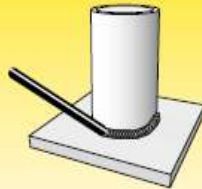

Pipe fixed vertical axis, welding
horizontal-vertical: PB/2F



Pipe fixed vertical axis, welding
overhead: PD/4F



Pipe fixed horizontal axis,
welding uphill: PH/5F



Pipe fixed horizontal axis,
welding downhill: PJ/5F

Glossary: Welding terms and definitions according to AWS A3.0M/A3.0:2010. Including terms for Adhesive Bonding, Brazing, Soldering, Thermal Cutting, and Thermal Spraying.

A

Abrasion soldering. A soldering process variation during which surface wetting is enhanced by abrading the faying surfaces.

Abrasive blasting. A method of cleaning or surface roughening by a forcibly projected stream of abrasive particles.

Acetylene feather. The intense white, feathery-edged portion adjacent to the cone of a carburizing oxyacetylene flame.

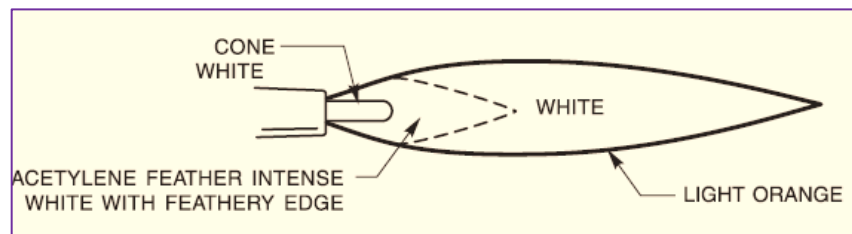

Acid core solder. A solder wire or bar containing acid flux as a core.

Activated rosin flux. A rosin-based flux containing an additive that increases wetting by the solder.

Adaptive control process. An operation with a control system sensing changes in conditions and automatically directing the equipment to take appropriate action. See adaptive control brazing, adaptive control soldering, adaptive control thermal cutting, adaptive control thermal spraying, and adaptive control welding. Adaptive control soldering (S-AD); Adaptive control thermal cutting (TC-AD). Adaptive control thermal spraying (TS-AD).

Agglomerated flux. A granular flux produced by baking a pelletized mixture of powdered ingredients and bonding agents at a temperature sufficient to remove the water, followed by processing to produce the desired particle size (*submerged arc welding*). See also bonded flux and fused flux.

Air Acetylene Welding (AAW). An oxyfuel gas welding process using an air-acetylene flame. The process is used without the application of pressure. This is an obsolete or seldom used process.

Air Carbon Arc Cutting (CAC-A). A carbon arc cutting process variation removing molten metal with a jet of air.

Air carbon arc cutting torch. A device used to transfer current to a fixed cutting electrode, position the electrode, and direct the flow of air.

Air feed. A thermal spraying process variation in which an air stream carries the powdered surfacing material through the gun and into the heat source.

Aligned discontinuities. Three or more discontinuities aligned approximately parallel to the weld axis, spaced sufficiently close together to be considered a single intermittent discontinuity.

Aligned porosity. A localized array of porosity oriented in a line.

Alloy. A substance with metallic properties and composed of two or more chemical elements of which at least one is a metal.

Alloy flux. A flux containing ingredients reacting with the filler metal to establish desired alloy content in the weld metal (*submerged arc welding*). **Active flux.** A flux formulated to produce a weld metal composition dependent on the welding parameters, especially arc voltage (*submerged arc welding*).

Alloy powder. Powder prepared from a homogeneous molten alloy or from the solidification product of such an alloy. See also powder blend.

Arc blow. The deflection of an arc from its normal path due to magnetic forces.

Arc Braze Welding (ABW). A braze welding process variation using an electric arc as the heat source. See also carbon arc braze welding.

Arc Cutting (AC). A group of thermal cutting processes severing or removing metal by melting with the heat of an arc between an electrode and the workpiece.

Arc cutting gun. A device used to transfer current to a continuously fed cutting electrode, guide the electrode, and direct the shielding gas. Arc cutting torch. See air carbon arc cutting torch, gas tungsten arc cutting torch, and plasma arc cutting torch.

Arc gouging. Thermal gouging using an arc cutting process variation to form a bevel or groove.

Arc length. The distance from the tip of the electrode to the adjacent surface of the weld pool.

Arc plasma. A gas heated by an arc to at least a partially ionized condition, enabling it to conduct an electric current.

Arc seam weld. A seam weld made by an arc welding process.

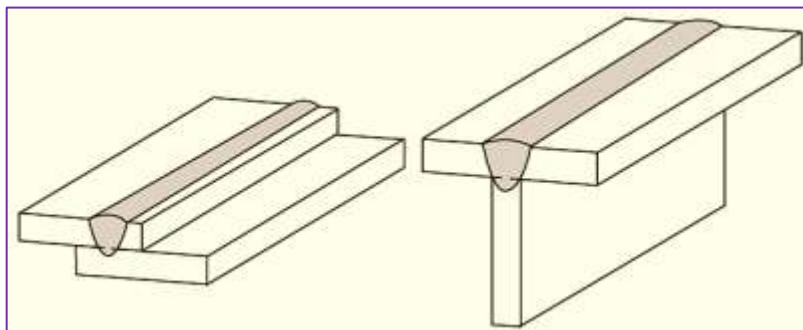

Arc Spraying (ASP). A thermal spraying process using an arc between two consumable electrodes of surfacing materials as a heat source and a compressed gas to atomize and propel the surfacing material to the substrate.

Arc strike. A discontinuity resulting from an arc, consisting of any localized melted metal, heat-affected metal, or change in the surface profile of any metal object.

Arc Stud Welding (SW). An arc welding process using an arc between a metal stud, or similar part, and the other workpiece. The process is used without filler metal, with or without shielding gas or flux, with or without partial shielding from a ceramic or graphite ferrule surrounding the stud, and with the application of pressure after the faying surfaces is sufficiently heated.

Arc time. The time during which an arc is maintained in making an arc weld.

Arc Welding (AW). A group of welding processes producing coalescence of workpieces by melting them with an arc. The processes are used with or without the application of pressure and with or without filler metal.

Arc welding deposition efficiency. The ratio of the weight of filler metal deposited in the weld metal to the weight of filler metal melted, expressed in percent.

Arc welding electrode. A component of the welding circuit through which current is conducted and that terminates at the arc.

Arc welding gun. A device used to transfer current to a continuously fed consumable electrode, guide the electrode, and direct the shielding gas. Arc welding torch. A device used to transfer current to a fixed welding electrode, position the electrode, and direct the shielding gas.

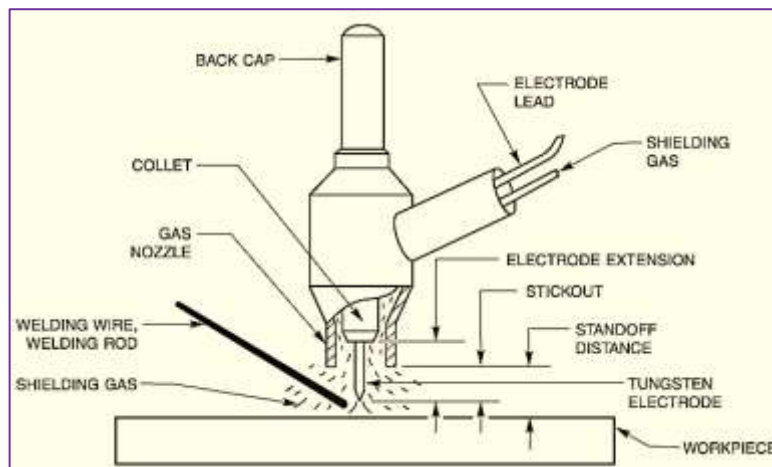

Assembly. One or more components, members, or parts fit in preparation for joining.

Assist gas. A gas used to blow molten metal away to form the kerf in laser beam inert gas cutting, or to blow vaporized metal away from the beam path in laser beam evaporative cutting.

Atomic Hydrogen Welding (AHW). An arc welding process using an arc between two metal electrodes in a shielding atmosphere of hydrogen and without the application of pressure. This is an obsolete or seldom used process..

Autogenous weld. A fusion weld made without filler metal.

Automatic arc welding current. The current in the welding circuit during the making of a weld, but excluding upslope, downslope, and crater fill current. Automatic arc welding downslope time. The time during which the current is changed continuously from final taper current or welding current to final current. Automatic arc welding upslope time. The time during which the current changes continuously from the initial current to the welding current.

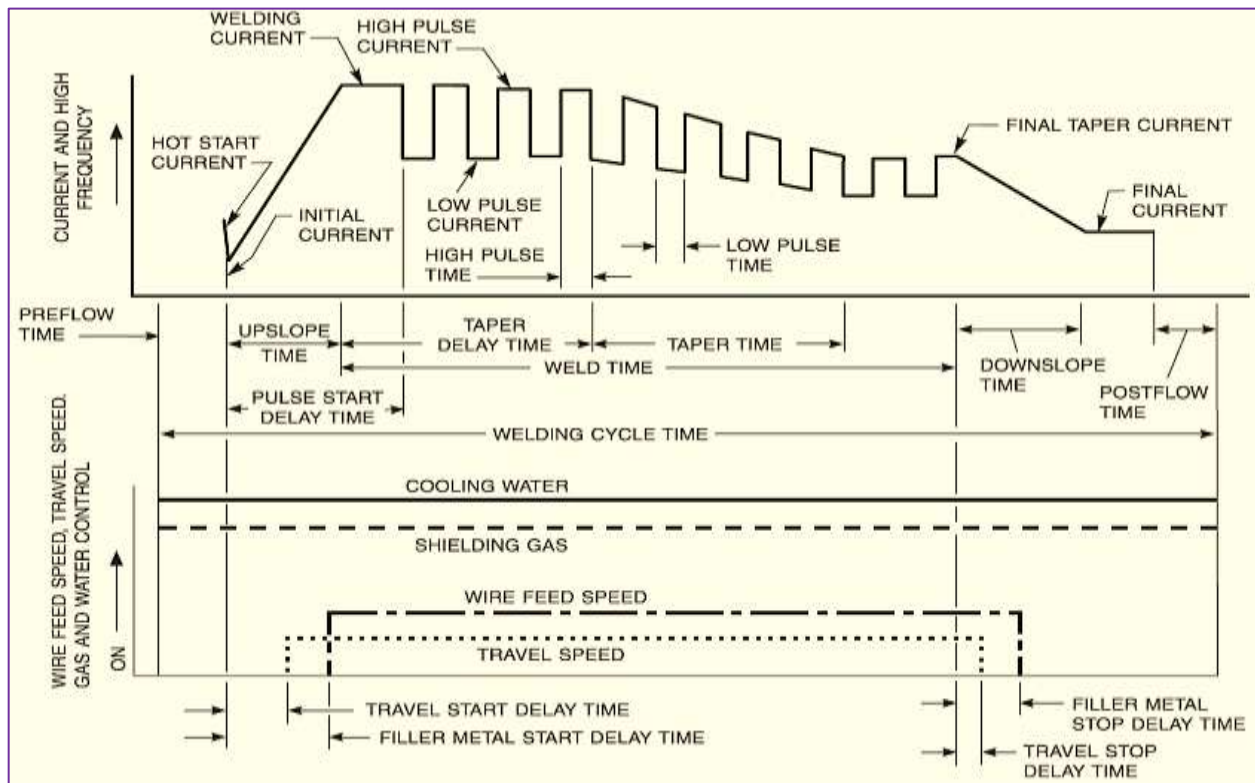

Automatic process. An operation performed with equipment requiring occasional or no observation and no manual adjustment during its operation. See automatic brazing, automatic soldering, automatic thermal cutting, automatic thermal spraying, and automatic welding, automatic soldering (S-AU), automatic thermal cutting (TC-AU), automatic thermal spraying (TS-AU), automatic welding (W-AU).

Automatic process arm. A beam extending from the frame of a resistance welding machine to transmit electrode force and sometimes conduct welding current.

Auxiliary magnifier. An additional lens used to magnify the field of vision.

B

Back bead. A weld bead resulting from a back weld pass.

Back cap. A device used to exert pressure on the collet in a gas tungsten arc welding torch and create a seal to prevent air from entering the back of the torch..

Back weld. A weld made at the back of a single groove weld.

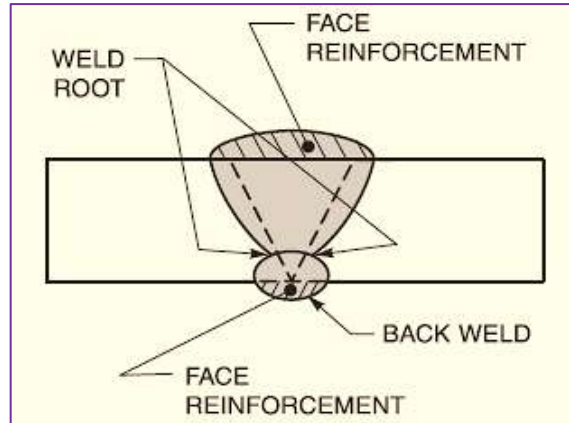

Backfire. The momentary recession of the flame into the torch, potentially causing a flashback or sustained backfire. It is usually signaled by a popping sound, after which the flame may either extinguish or reignite at the end of the tip. See also flashback and sustained backfire.

Back-gouging. The removal of weld metal and base metal from the weld root side of a welded joint to facilitate complete fusion and complete joint penetration upon subsequent welding from that side.

Backhand welding. A welding technique in which the welding torch or gun is directed opposite to the progress of welding. See drag angle, forehand welding, push angle, travel angle, and work angle.

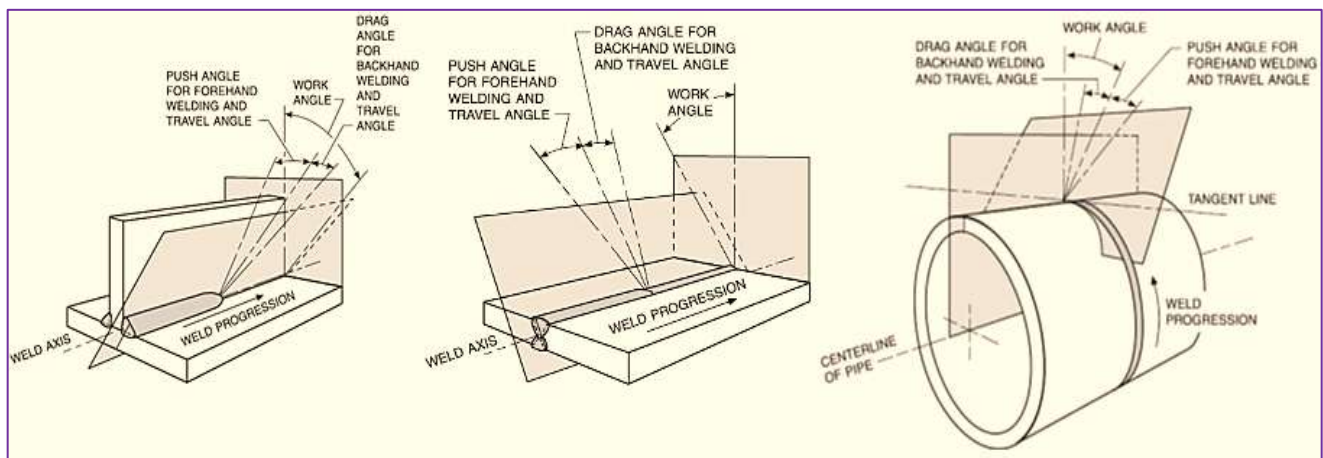

Backing. A material or device placed against the back side of the joint adjacent to the joint root, or at both sides of a joint in electroslag and electrogas welding, to support and shield molten weld metal. The material may be partially fused or remain unfused during welding and may be either metal or nonmetal.

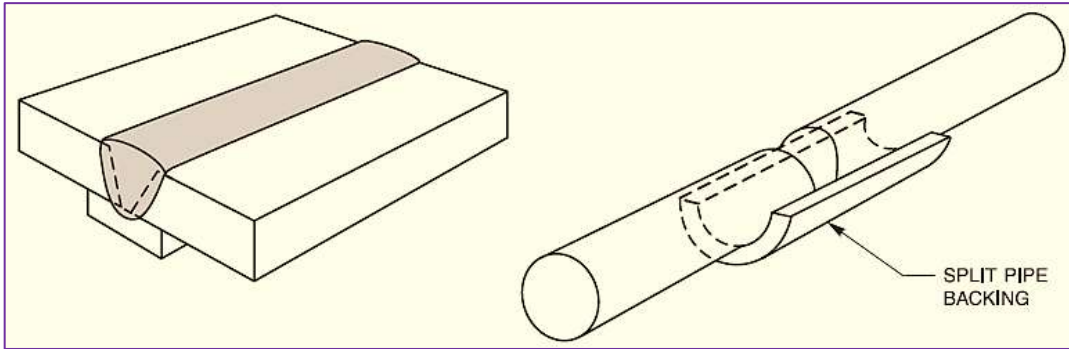

Backing gas. Backing in the form of a shielding gas employed primarily to provide a protective atmosphere.

Backing ring. Backing in the form of a ring, generally used in the welding of pipe.

Backing shoe. A barrier device used in electroslag and electrogas welding to contain the weld without being fused. See also moving shoe and stationary shoe.

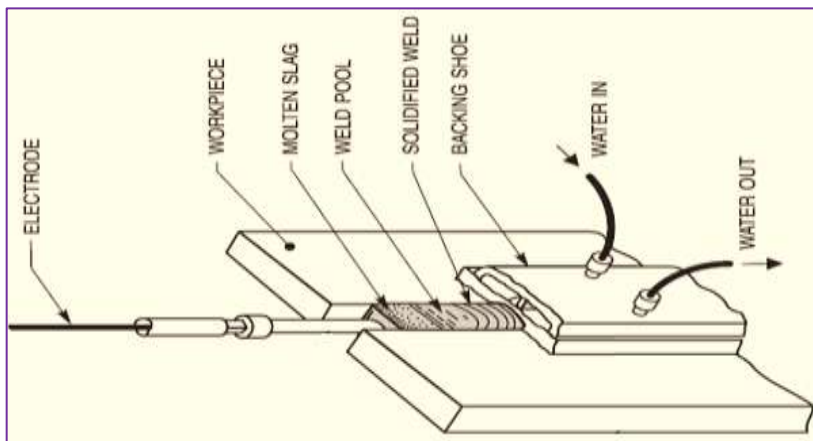

Backstep sequence. A longitudinal sequence in which weld passes are made in the direction opposite to the progress of welding.

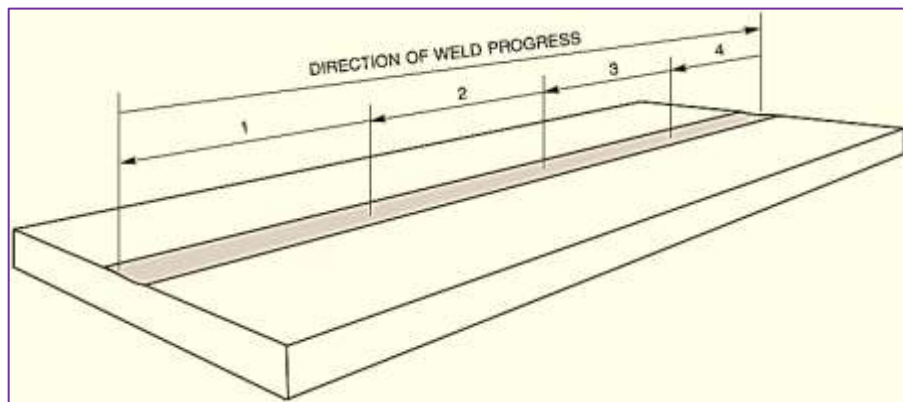

Backup. A locating device used to transmit all or a portion of the upset force to the workpieces or to aid in preventing the workpieces from slipping during upsetting. Backup electrode. An electrode having a large electrode face opposing the welding force.

Balling up. The formation of globules of molten filler metal or flux due to insufficient base metal wetting (*brazing and soldering*).

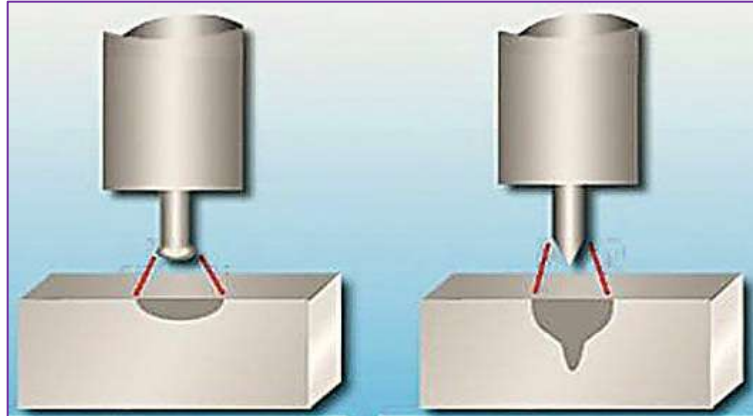

Bare electrode. A filler metal electrode produced as a wire, strip, or bar with no coating or covering except one incidental to its manufacture or preservation.

Bare Metal Arc Welding (BMAW). An arc welding process using an arc between a bare or lightly coated electrode and the weld pool. The process is used without shielding, without the application of pressure, and filler metal is obtained from the electrode. This is an obsolete or seldom used process..

Base metal. The metal or alloy being welded, brazed, soldered, or cut. See base material and substrate. Base metal test specimen. A test specimen composed wholly of base metal.

Base Metal Zone (BMZ). The portion of base metal adjacent to a weld, braze or solder joint or thermal cut and unaffected by welding, brazing, soldering, or thermal cutting. See heat-affected zone and weld metal zone.

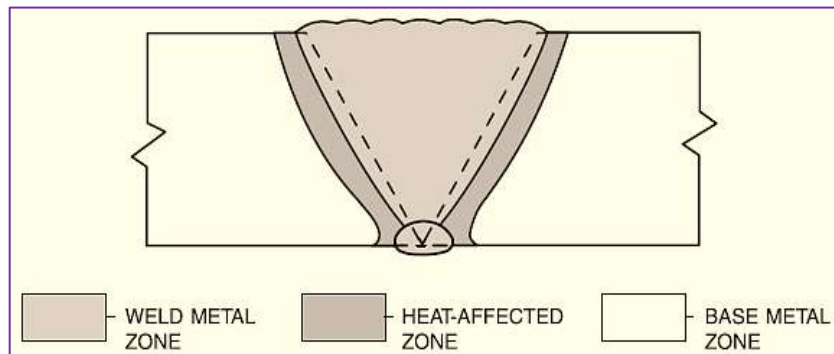

Beam divergence. The expansion of a beam's cross section as the beam emanates from its source.

Bend test. A test in which a specimen is bent to a specified bend radius. See face bend test, root bend test, and side bend test.

Berry formation. A nonstandard term for nozzle accumulation.

Bevel angle. The angle between the bevel of a joint member and a plane perpendicular to the surface of the member. **Bevel edge shape.** A type of edge shape in which the prepared surface or surfaces lies at some angle other than perpendicular to the material surface. **Bevel radius.** The radius used to form a J-edge shape.

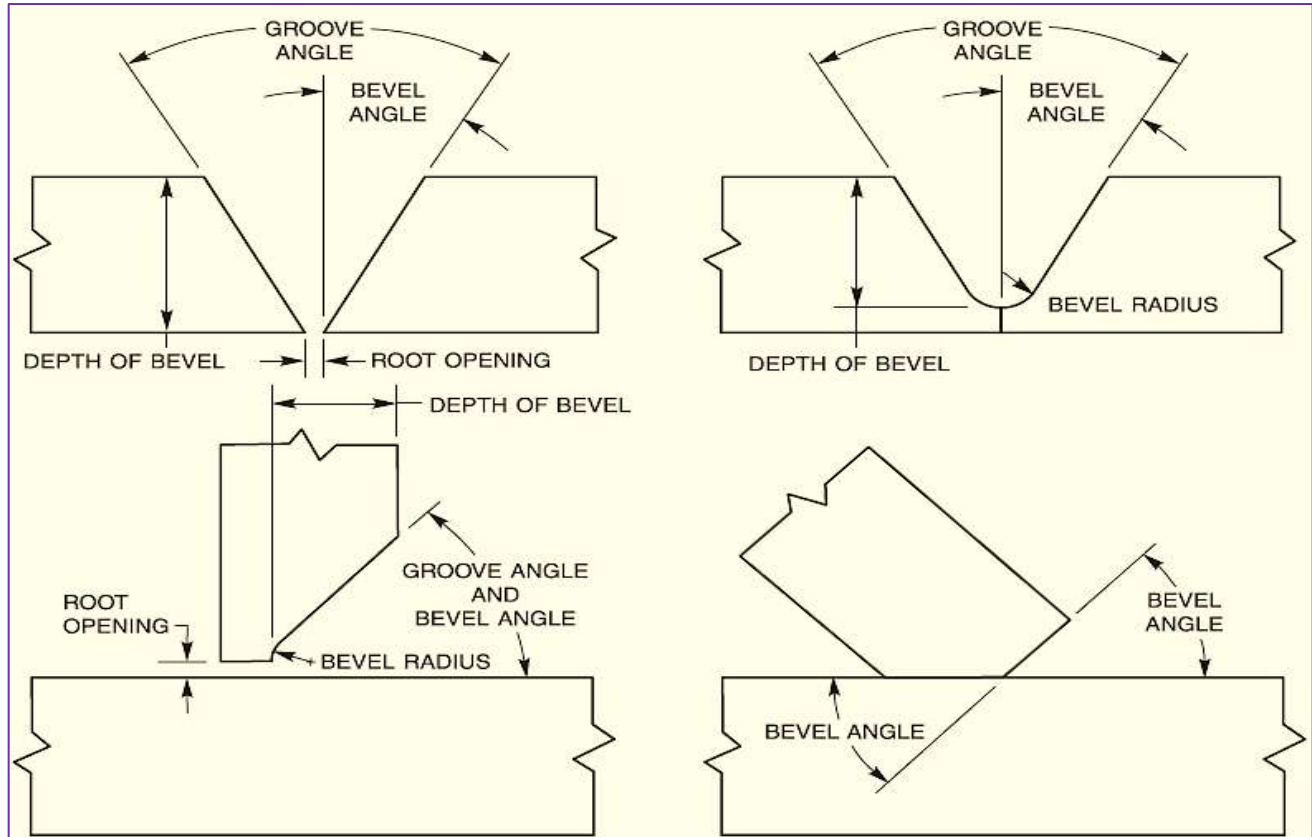

Bevel face. The prepared surface of a bevel edge shape. **Bevel-groove weld.** A type of groove weld.

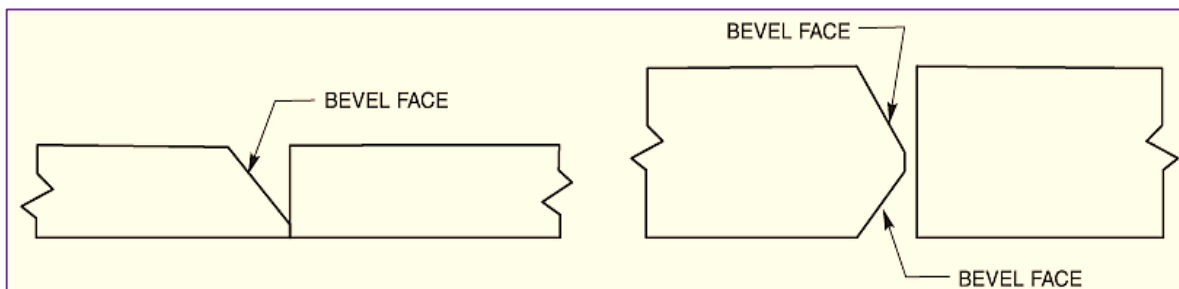

Bit. Part of the soldering iron, usually made of copper, provided to directly transfer heat, and sometimes soldering filler metal, to the joint.

Blacksmith welding. A nonstandard term when used for forge welding.

Blanket brazing. A brazing process variation employing a flexible, resistance-heated blanket(s) as the heat source.

Blind joint. A joint, no portion of which is visible.

Block brazing (BB). A brazing process employing heated blocks as the heat source. This is an obsolete or seldom used process.

Block sequence. A combined longitudinal and cross-sectional sequence for a continuous multiple-pass weld in which separated segments are completely or partially welded before intervening segments are welded. See also cascade sequence, cross-sectional sequence, progressive block sequence, and selective block sequence.

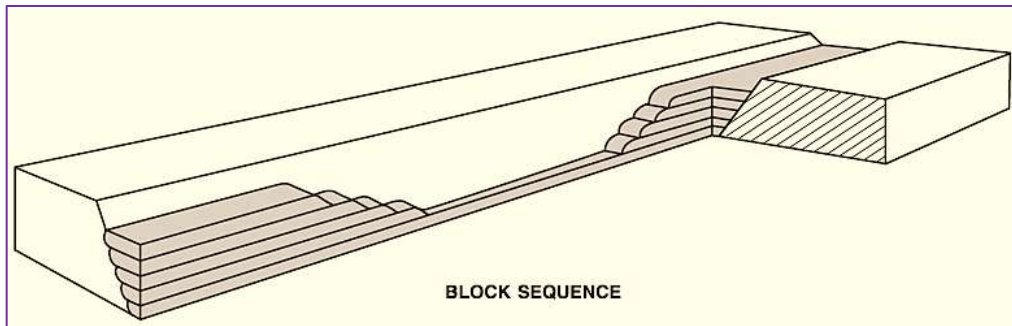

Blowhole. A nonstandard term when used for porosity.

Bond. See covalent bond, ionic bond, mechanical bond, and metallic bond, bond cap, bond bar, (nonstandard term for bond specimen).

Bonded flux. A granular flux produced by baking a pelletized mixture of powdered ingredients and bonding agents at a temperature below its melting point, but high enough to create a chemical bond, followed by processing to produce the desired particle size. See agglomerated flux and fused flux.

Bond line. The cross section of the interface between a thermal spray deposit and the substrate. Bond coat. A preliminary (or prime) coat of material applied to improve adherence of the subsequent thermal spray deposit. Bond specimen. The test specimen on which a thermal spray deposit has been applied to determine bond strength and thermal spray deposit strength (*thermal spraying*).

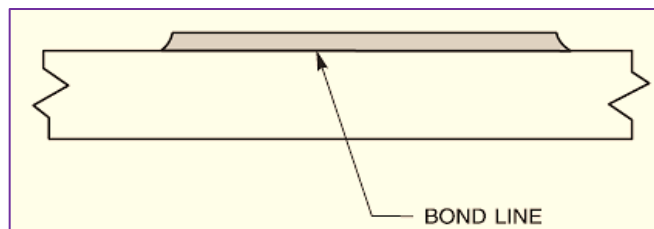

Bottle. A nonstandard term when used for gas cylinder.

Boxing. The continuation of a fillet weld around a corner of a member as an extension of the principal weld.

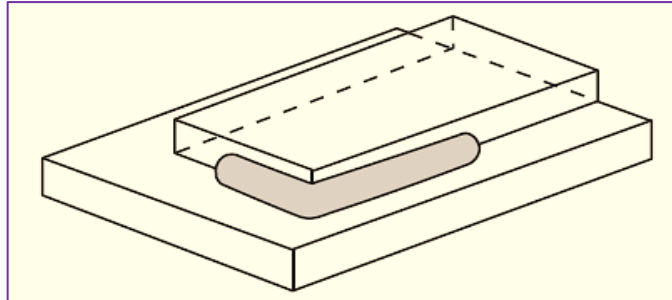

Braze. A bond produced as a result of heating an assembly to the brazing temperature using a brazing filler metal distributed and retained between the closely fitted faying surfaces of the joint by capillary action. Braze interface. The boundary between braze metal and base material in a brazed joint. Braze metal. The portion of a braze that has been melted during brazing. Brazed joint. A joint that has been brazed. Braze, v. The act of brazing.

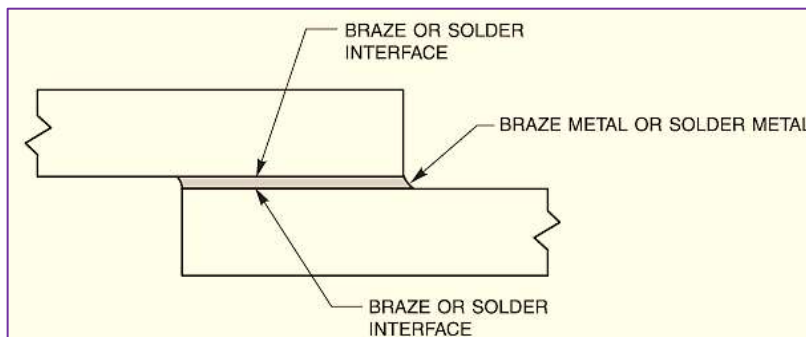

Braze Welding (BW). A joining process in which the brazing filler metal is deposited in the joint without capillary action or melting of the base material. See arc braze welding, carbon arc braze welding, electron beam braze welding, exothermic braze welding, and laser beam braze welding.

Brazing. A group of joining processes producing the bonding of materials by heating them to the brazing temperature in the presence of a brazing filler metal having a liquid above 450°C [840°F] and below the solidus of the base metal. The brazing filler metal is distributed and retained between the closely fitted faying surfaces of the joint by capillary action.

Brazing filler metal. The metal or alloy to be added in making a brazed joint. The filler metal has a liquid above 450°C [840°F] and below the solidus of the base material. See brazing foil, brazing filler metal paste, brazing powder, brazing rod, brazing rope, brazing sheet, brazing strip, brazing tape, and brazing wire. Brazing filler metal paste. Brazing filler metal in the form of a paste consisting of finely divided brazing filler metal with a flux or neutral carrier.

Brazing foil. Brazing filler metal in thin sheet form. Brazing flux. A flux used for brazing. See noncorrosive flux. See soldering flux and welding flux. Brazing powder. Brazing filler metal in the form of finely divided particles. Brazing blowpipe. A device used to obtain a small, accurately directed flame for fine work. A portion of any flame is blown to the desired location by the blowpipe, which is usually mouth operated.

Brazing Procedure Qualification Record (BPQR). A record of brazing variables used to produce an acceptable test brazement and the results of tests conducted on the brazement to qualify a brazing procedure specification.

Brazing Procedure Specification (BPS). A document specifying the required brazing variables for a specific application. Brazing procedure. The detailed methods and practices involved in the production of a brazement..

Brazing rod. A form of solid or flux cored brazing filler metal supplied in straight lengths that may include a flux coating. Brazing rope. Brazing powder held in an extruded form by a plastic binder. Brazing sheet. Brazing powder held in sheet form by a plastic binder. Brazing strip. A long, narrow form of brazing foil or brazing sheet. Brazing temperature. The base material temperature(s) at which a braze can be accomplished. Brazing wire. A solid or flux cored form of brazing filler metal supplied on coils or spools.

Brazing symbol. A graphical representation of the specifications for producing a brazed joint. For examples and rules for their application, refer to AWS A2.4, *Standard Symbols for Welding, Brazing, and Nondestructive Examination*.

Brittle nugget. Used to describe a faying plane failure of a weld in a peel test. Button. Part of a weld, including all or part of the nugget, torn out in the destructive testing of projection, seam, or spot welds.

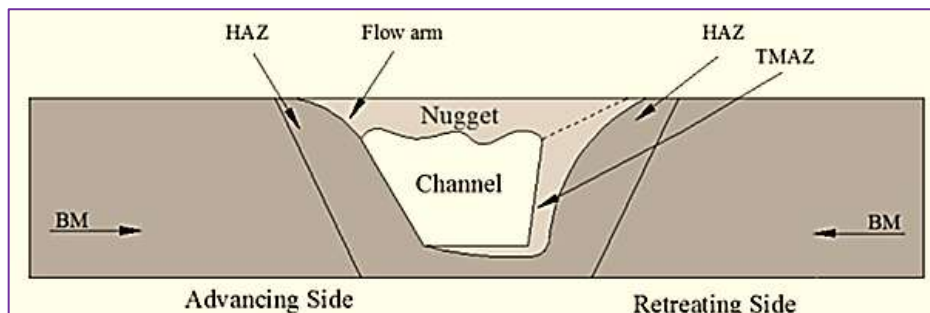

Buildup. A surfacing variation in which surfacing material is deposited to achieve the required dimensions. See also buttering, cladding, and hard-facing. Buildup sequence. A nonstandard term for cross-sectional sequence.

Burner. A nonstandard term when used for oxyfuel gas cutter. Burning. A nonstandard term when used for oxyfuel gas cutting. Burning in. A nonstandard term for flow welding. Burn-off rate. A nonstandard term when used for melting rate.

Burn-through. A hole or depression in the root bead of a single-groove weld due to excess penetration. Burn-through weld. A nonstandard term for an arc seam weld or arc spot weld.

Butt joint. A joint type in which the butting ends of one or more workpieces are aligned in approximately the same plane. See skewed joint. Butt weld. A nonstandard term for a weld in a butt joint.

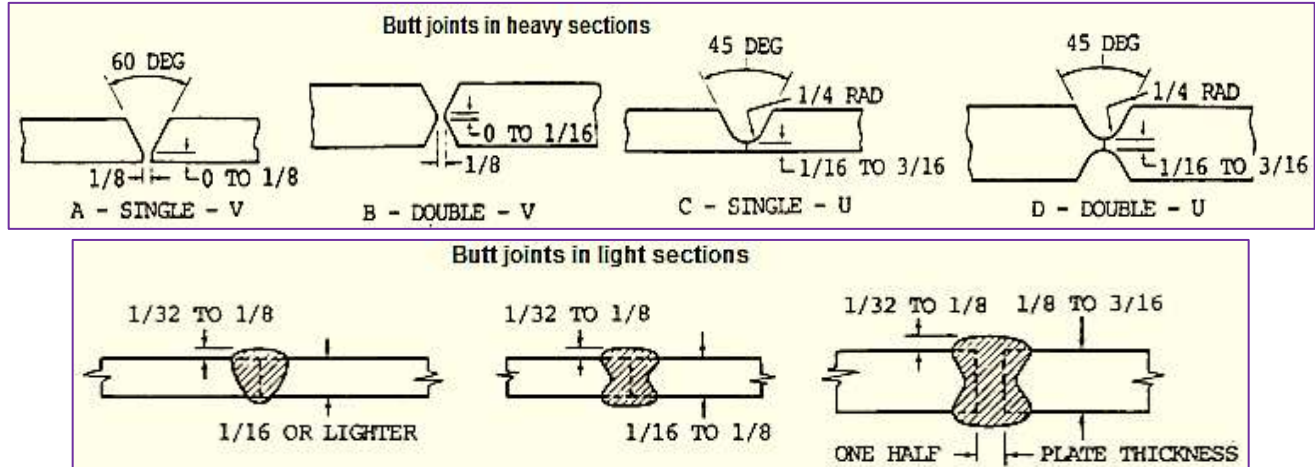

Buttering. A surfacing variation depositing surfacing metal on one or more surfaces to provide metallurgically compatible weld metal for the subsequent completion of the weld. See also buildup, cladding, and hard-facing.

Butting member. A joint member prevented, by the other member, from movement in one direction perpendicular to its thickness dimension. For example, both members of a butt-joint, or one member of a T-joint and corner joint. See also non-butting member.

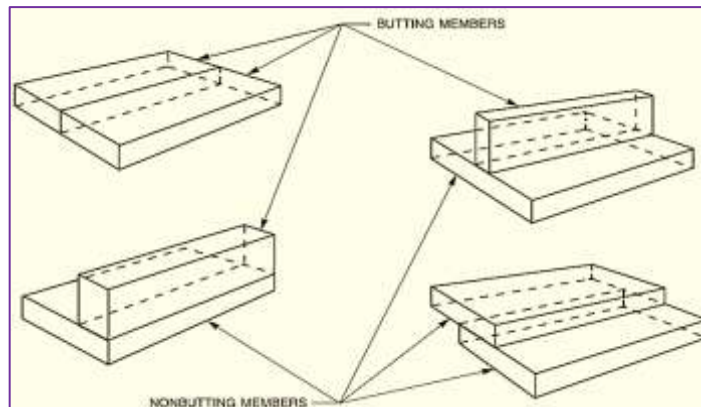

C

Cap. A nonstandard term for the final layer of a groove weld. Cap, *resistance welding*. A nonstandard term for electrode cap.

Capillary action. The force by which liquid in contact with a solid is distributed between the closely fitted faying surfaces of the joint to be brazed or soldered.

Carbon Arc Braze Welding (CABW). A braze welding process variation using an arc between a carbon electrode and the base metal as the heat source.

Carbon Arc Brazing (CAB). A brazing process using heat from a carbon arc. This is an obsolete or seldom used process. Carbon arc brazing. A nonstandard term used for twin carbon arc brazing.

Carbon Arc Cutting (CAC). An arc cutting process employing a carbon electrode. See also air carbon arc cutting.

Carbon Arc Gouging (CAG). A thermal gouging process using heat from a carbon arc and the force of compressed air or other nonflammable gas. See also oxygen gouging and plasma arc gouging.

Carbon Arc Welding (CAW). An arc welding process using an arc between a carbon electrode and the weld pool. The process is used with or without shielding and without the application of pressure. See also gas carbon arc welding, shielded carbon arc welding, and twin carbon arc welding.

Carbon electrode. A non-filler metal electrode used in arc welding and cutting, consisting of a carbon or graphite rod, which may be coated with copper or other materials.

Carburizing flame. A reducing oxyfuel gas flame in which there is an excess of fuel gas, resulting in a carbon-rich zone extending around and beyond the cone. See also neutral flame, oxidizing flame, and reducing flame.

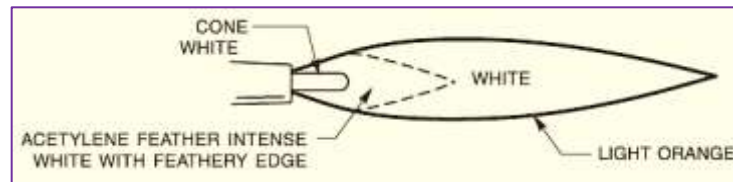

Carrier gas. The gas used to transport powdered material from the feeder or hopper to a thermal spraying gun or a thermal cutting torch.

Cascade sequence. A combined longitudinal and cross-sectional sequence in which weld beads are made in overlapping layers. See also block sequence, continuous sequence, and cross-sectional sequence.

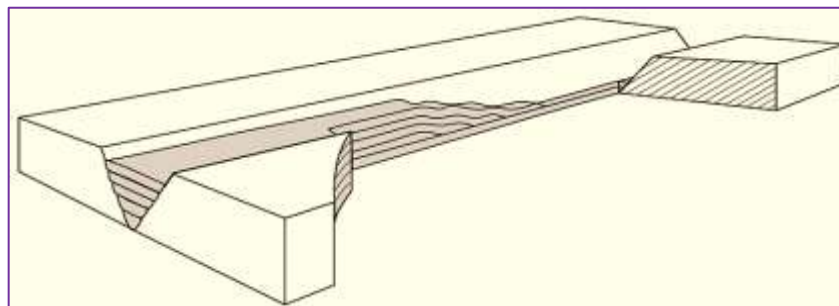

Caulk weld. A nonstandard term for seal weld. Caulking. Plastic deformation of weld and adjacent base metal surfaces by mechanical means to seal or obscure discontinuities.

Ceramic rod flame spraying. A thermal spraying process variation in which the surfacing material is in rod form.

Chain intermittent weld. An intermittent weld on both sides of a joint in which the weld segments on one side are approximately opposite those on the other side.

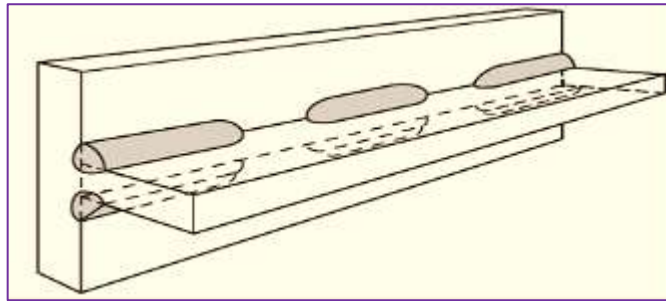

Chemical-bath dip brazing. A dip brazing process variation using a chemical compound also serving as a flux. See also metal-bath dip brazing and salt-bath dip brazing.

Chill ring. A nonstandard term when used for backing ring. Chill time. A nonstandard term when used for quench time.

Circular electrode. A rotatable electrode with the contacting surface at the periphery through which welding current and force are applied to the workpieces. See resistance welding electrode.

Clad metal. A laminar composite consisting of a metal or alloy, with a metal or alloy of different chemical composition applied to one or more sides by casting, drawing, rolling, surfacing, chemical deposition, or electroplating.

Cladding. A surfacing variation depositing or applying surfacing material usually to improve corrosion or heat resistance. See also buildup, buttering, and hard-facing. Clad brazing sheet. A metal sheet on which one or both sides are clad with brazing filler metal. See also clad metal.

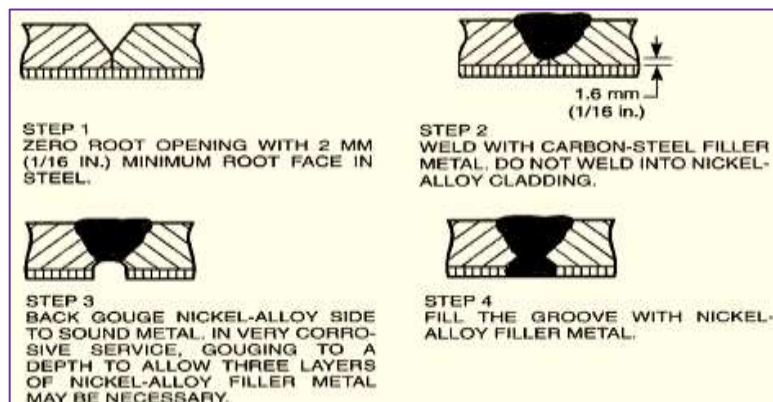

Cluster porosity. A localized array of porosity having a random geometric distribution.

CO₂ welding. A nonstandard term when used for flux cored arc welding or gas metal arc welding with carbon dioxide shielding gas.

Coalescence. The growing together or growth into one body of the materials being joined.

Coated electrode. A nonstandard term for covered electrode or lightly coated electrode.

Co-extrusion Welding (CEW). A solid-state welding process producing a weld by heating to the welding temperature and forcing the workpieces through an extrusion die.

Coil without support. A filler metal packaging configuration in which the wire is coiled without an internal support and appropriately bound to maintain its shape. **Coil with support.** A filler metal packaging configuration in which the wire or strip is wound around a cylinder without flanges.

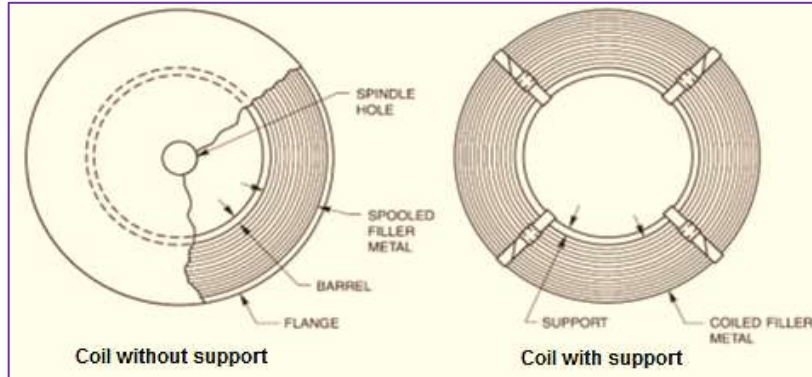

Cold brazed joint. A brazed joint with incomplete metallic bonding due to insufficient heating of the base material during brazing.

Cold crack. A crack occurring in a metal at or near ambient temperatures. Cold cracks can occur in base metal (BMZ), heat-affected (HAZ), and weld metal zones (WMZ). See also hot crack.

Cold lap. A nonstandard term when used for incomplete fusion or overlap, *fusion welding*.

Cold soldered joint. A soldered joint with incomplete metallic bonding due to insufficient heating of the base material during soldering.

Cold Welding (CW). A solid-state welding process in which pressure is used to produce a weld at room temperature with substantial deformation at the weld. See also diffusion welding, forge welding, and hot pressure welding.

Collet. A mechanical clamping device used to hold the electrode in position within the welding, cutting or spraying torch (*gas tungsten arc welding, plasma arc cutting, plasma arc welding, and thermal spraying*). See figure in Arc Welding Gun.

Commutator-controlled welding. A resistance spot or projection welding variation in which multiple welds are produced sequentially as controlled by a commutating device activated when the contactor is closed.

Complete fusion. Fusion over the entire fusion faces and between all adjoining weld beads. See also incomplete fusion. Complete joint penetration weld. A groove weld in which weld metal extends through the joint thickness. See also complete joint penetration, incomplete joint penetration, joint penetration, and partial joint penetration weld.

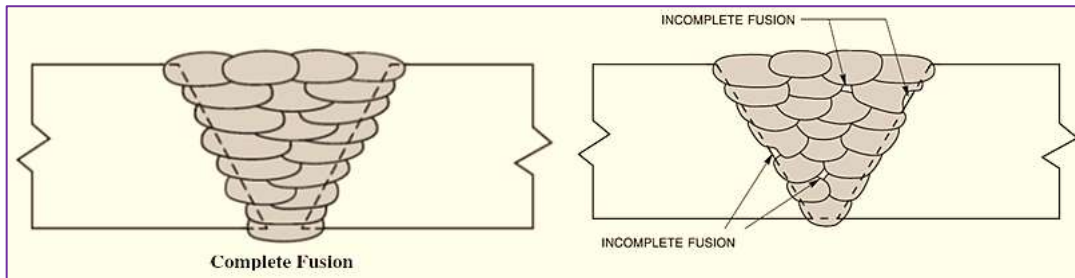

Complete Joint Penetration (CJP). A groove weld condition in which weld metal extends through the joint thickness. See also complete joint penetration weld, incomplete joint penetration, joint penetration, and partial joint penetration weld. See figure complete fusion.

Composite. A material consisting of two or more discrete materials with each material retaining its physical identity. See also clad metal, composite electrode, and composite thermal spray deposit.

Composite electrode. A generic term for multicomponent filler metal electrodes in various physical forms such as stranded wires, tubes, and covered wire. See also covered electrode, flux cored electrode, metal cored electrode, and stranded electrode.

Composite thermal spray deposit. A thermal spray deposit made with two or more dissimilar surfacing materials that may be formed in layers.

Concave and convex fillet weld. Is a fillet weld having a concave face. Convex fillet weld. Is a fillet weld having a convex face. Concave or convex root surface. The configurations of a fillet groove weld exhibiting the under fill at a root surface. Concavity and convexity of a fillet weld. The maximum distance from the face of a concave or convex fillet weld, perpendicular to a line joining the weld toes.

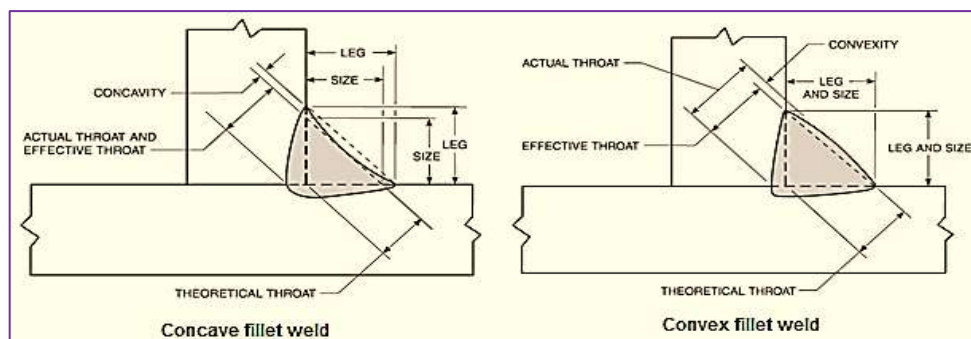

Constant voltage power source. An arc welding power source with a volt-ampere relationship yielding a large welding current change from a small arc voltage change. See welding power source.

Constricted arc. A plasma arc column shaped by the constricting orifice in the nozzle of the plasma arc torch or plasma spraying gun. **Constricting nozzle.** A device at the exit end of a plasma arc torch or plasma spraying gun, containing the constricting orifice. **Constricting orifice.** The hole in the constricting nozzle of the plasma arc torch or plasma spraying gun through which the arc plasma passes.

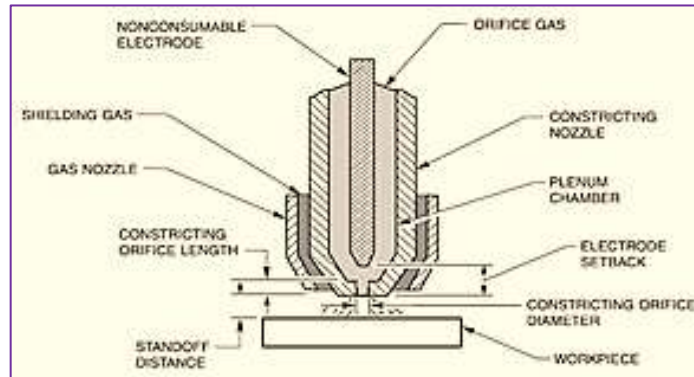

Consumable Guide Electroslag Welding (ESW-CG). An electroslag welding process variation in which filler metal is supplied by an electrode and its guiding member. See figure backing shoe.

Consumable insert. Filler metal placed at the joint root before welding, and intended to be completely fused into the joint root to become part of the weld.

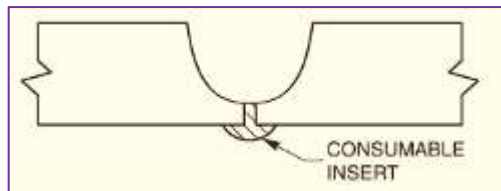

Contact tip. A tubular component of an arc welding gun delivering welding current to, and guiding, a continuous electrode. **Contact tip setback.** The distance from the contact tip to the end of the gas nozzle. **Contact resistance.** Resistance to the flow of electric current through faying surfaces of an electrode and workpiece, or mating surfaces of components in the secondary circuit.

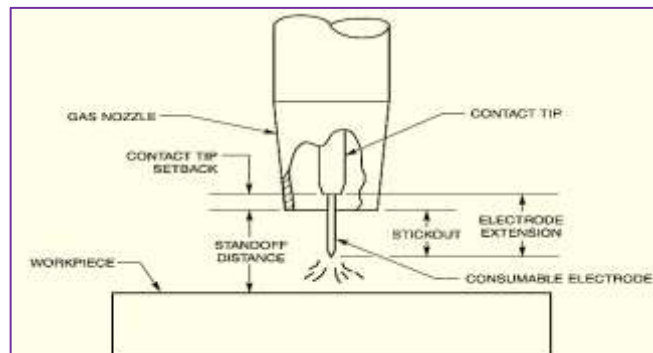

Continuous wave laser. A laser having an output operating in a continuous rather than a pulsed mode. A laser operating with a continuous output for a period greater than 25 milliseconds is regarded as a continuous wave laser.

Continuous weld. A weld extending continuously from one end of a joint to the other. Where the joint is essentially circular, it extends completely around the joint. Cool time. The duration between successive heat times in multiple-impulse welding.

Cord. Surfacing material in the form of a plastic tube filled with powder extruded to a compact, flexible cord with characteristics similar to a wire (*thermal spraying*).

Cored solder. A solder wire or bar containing flux as a core.

Corner joint. A joint type in which butting or non-butting ends of one or more workpieces converge approximately perpendicular to one another. Corner-flange weld. A term used for an edge weld in a flanged corner joint. See skewed joint.

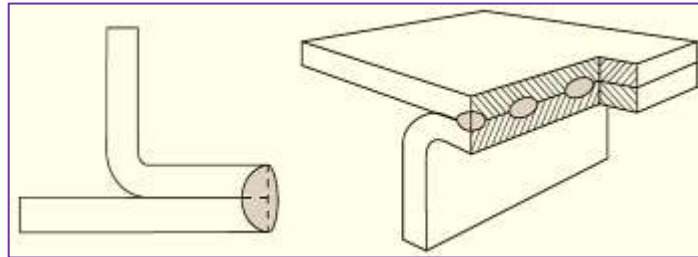

Corona. The region of a resistance weld where joining is the result of solid-state welding.

Corrosive flux. A flux with a residue chemically attacking the base metal. It may be composed of inorganic salts and acids, organic salts and acids, or activated rosin (*brazing and soldering*).

Cosmetic weld bead. A weld bead used to enhance appearance. Cosmetic weld pass. A weld pass resulting in a cosmetic weld bead.

Covalent bond. A primary bond arising from the reduction in energy associated with overlapping half-filled orbitals of two atoms.

Cover pass. A weld pass or passes resulting in the exposed layer of a multipass weld on the side from which welding was done.

Cover plate. A removable pane of colorless glass, plastic-coated glass, or plastic covering the filter plate and protecting it from weld spatter, pitting, or scratching.

Covered electrode. A composite filler metal electrode consisting of a bare or metal cored electrode with a flux covering sufficient to provide a slag layer and/or alloying elements. See also lightly coated electrode.

Crack and Crater. Crack is a fracture-type discontinuity characterized by a sharp tip and high ratio of length and width to opening displacement. Crater is a depression in the weld face at the termination of a weld bead. Crater crack. A crack initiated and localized within a crater. Crater fill time. The time interval following weld time but prior to melt-back time during which arc voltage or current reach a pre-set value greater or less than welding values. Weld travel may or may not stop at this point.

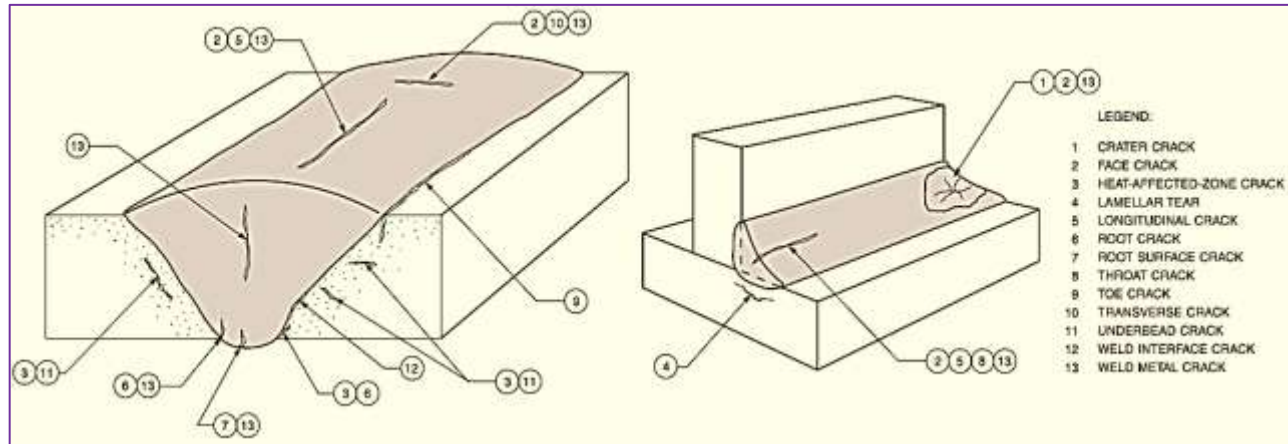

Cross-wire welding. A projection welding joint design in which the localization of the welding current and force is achieved by the contact of intersecting wires. Cross-sectional sequence. The order in which the weld passes of a multiple-pass weld are made with respect to the cross section of the weld. See block sequence, cascade sequence, and continuous sequence.

Cutting electrode. A non-filler metal electrode used in arc cutting. See carbon electrode, metal electrode, and tungsten electrode. Cutting attachment. A device for converting an oxyfuel gas welding torch into an oxyfuel gas cutting torch. Cutting blowpipe. A term used for oxyfuel gas cutting torch.

Cutting nozzle. A term used for cutting tip. Cutting head. The part of a cutting machine in which a cutting torch or tip is incorporated. Cutting tip. The part of an oxyfuel gas cutting torch from which the gases issue. Cutting torch. See air carbon arc cutting torch, gas tungsten arc cutting torch, oxyfuel gas cutting torch, and plasma arc cutting torch.

Cycle. The duration of one waveform period.

Cylinder manifold. A header for interconnection of multiple gas sources with distribution points.

D

Defect. A discontinuity or discontinuities that by nature or accumulated effect render a part or product unable to meet minimum applicable acceptance standards or specifications. The term designates rejectability. See weld discontinuity and flaw.

Deposit. A nonstandard term when used for thermal spray deposit. Deposit sequence. A nonstandard term when used for weld pass sequence. Deposited metal. Filler metal added during brazing, soldering or welding. Surfacing metal added during surfacing (*brazing, soldering, and welding*).

Deposition efficiency. See arc welding deposition efficiency and thermal spraying deposition efficiency. Deposition rate. The weight of material deposited in a unit of time. Deposition sequence. A nonstandard term when used for weld pass sequence.

Depth of fusion. The distance that fusion extends into the base metal or previous bead from the surface melted during welding. Depth of bevel. The perpendicular distance from the base metal surface to the root edge or the beginning of the root face. See joint penetration.

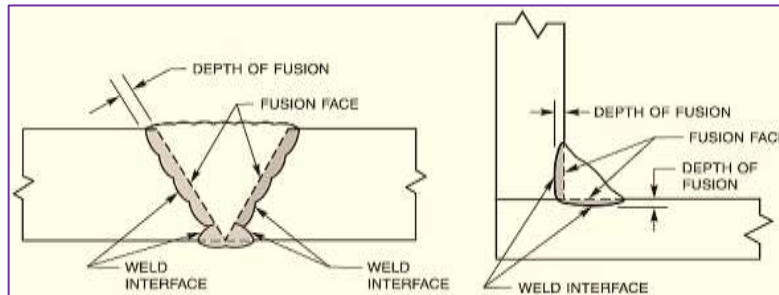

Detonation flame spraying. A thermal spraying process variation in which the controlled explosion of a mixture of fuel gas, oxygen, and powdered surfacing material is utilized to melt and propel the surfacing material to the substrate.

Die. A nonstandard term used for resistance welding die. Die welding. A term used for cold welding and forge welding.

Differential thermal expansion. Dimensional effects resulting from differences in expansion coefficients and/or thermal gradients within a workpiece or assembly.

Diffusion aid. A solid filler metal applied to the faying surfaces to assist in diffusion welding. Diffusion bonding. A nonstandard term for diffusion brazing and diffusion welding.

Diffusion Brazing (DFB). A brazing process using a brazing filler metal or an in situ liquid phase that diffuses with the base material(s) to produce joint properties approaching those of the base material(s). Pressure may or may not be applied.

Diffusion Welding (DFW). A solid-state welding process producing a weld by the application of pressure at elevated temperature with no macroscopic deformation or relative motion of the workpieces. A solid filler metal may be inserted between the faying surfaces. See cold welding, diffusion aid, forge welding, and hot pressure welding.

Dilution. The change in chemical composition of a welding filler metal caused by the admixture of the base metal or previous weld metal in the weld bead. It is measured by the percentage of base metal or previous weld metal in the weld bead.

Dip Brazing (DB). A brazing process using heat from a molten bath. See also chemical-bath dip brazing, metal-bath dip brazing, and salt-bath dip brazing.

Dip feed. A process variation in which filler metal is intermittently fed into the leading edge of the weld pool (*gas tungsten arc welding, oxyfuel gas welding and plasma arc welding*).

Dip Soldering (DS). A soldering process using heat from a metal, oil, or salt bath in which it is immersed. See wave soldering, metal-bath dip soldering, oil-bath dip, and salt-bath dip soldering.

Direct Current Electrode Negative (DCEN). The arrangement of direct current arc welding leads in which the *electrode is the negative pole and workpiece is the positive pole* of the welding arc.

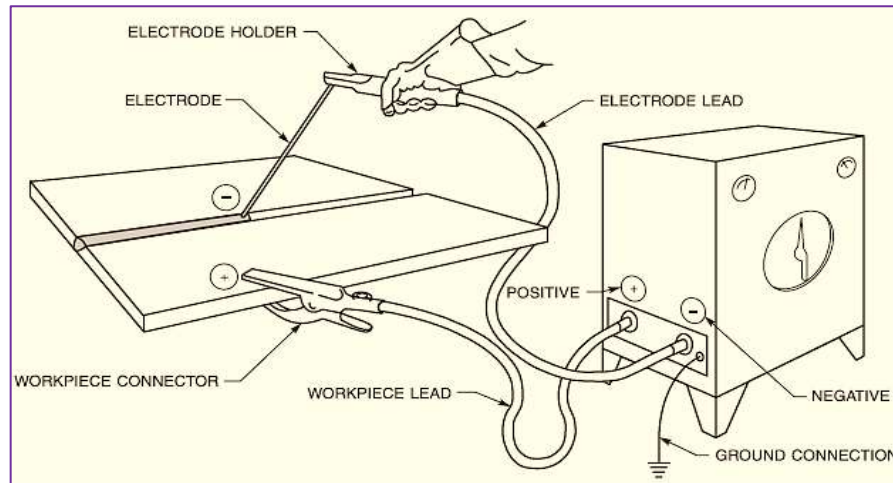

Direct Current Electrode Positive (DCEP). The arrangement of direct current arc welding leads in which the *electrode is the positive pole and the workpiece is the negative pole* of the welding arc. Direct current reverse polarity. A nonstandard term for direct current electrode positive. Direct current straight polarity. A nonstandard term for direct current electrode negative.

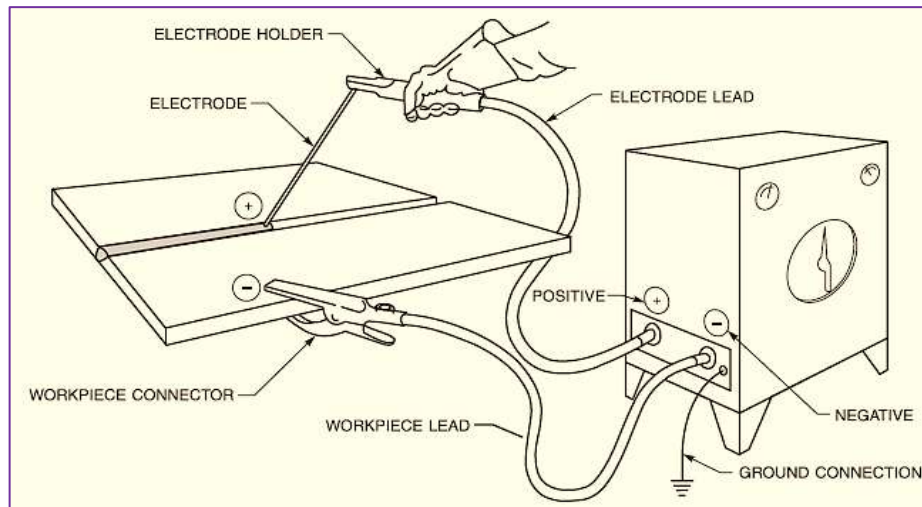

Direct Drive Friction Welding (FRW-DD). A variation of friction welding in which the energy required to make the weld is supplied to the welding machine through a direct motor connection for a preset period of the welding cycle. See inertia friction welding.

Direct welding. A secondary circuit configuration in which welding current and force are applied to workpieces by directly opposed electrodes (*resistance welding*).

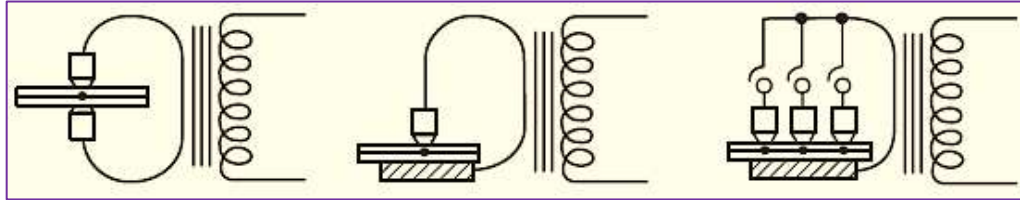

Discontinuity. An interruption of the typical structure of a material, such as a lack of homogeneity in its mechanical, metallurgical, or physical characteristics. A discontinuity is not necessarily a defect. See weld defect and flaw.

Dissolution. Dissolving of the base material into the filler metal or the filler metal into the base material (*brazing*).

Double arcing. A condition in which the welding or cutting arc of a plasma arc torch does not pass through the constricting orifice but transfers to the inside surface of the nozzle. A secondary arc is simultaneously established between the outside surface of the nozzle and the workpiece.

Double-bevel edge shape. A type of bevel edge shape having two prepared surfaces adjacent to opposite sides of the material.

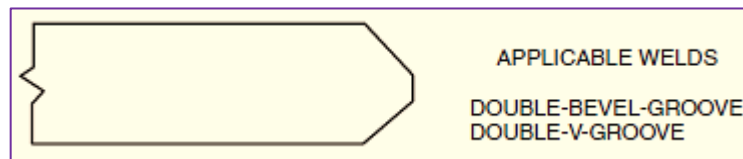

Double-bevel groove. A double-sided weld groove formed by the combination of a butting member having a double-bevel edge shape abutting a planar surface of a companion member. Double-bevel-groove weld. A weld in a double-bevel groove welded from both sides.

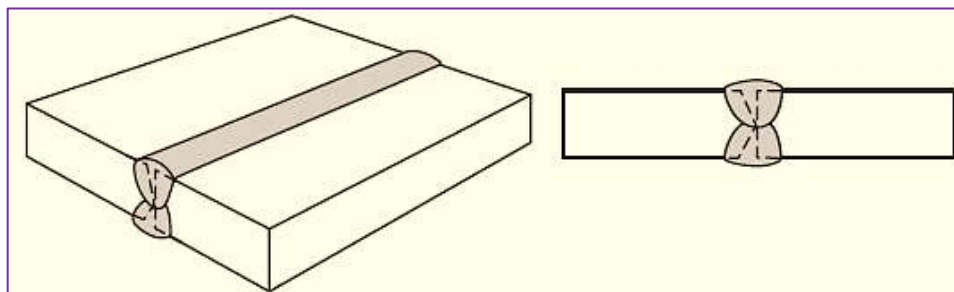

Double-flare-bevel groove. A double-sided weld groove formed by the combination of a butting member having a round edge shape and a planar surface of a companion member. Double-flare-bevel-groove weld. A weld in a double flare-bevel groove welded from both sides.

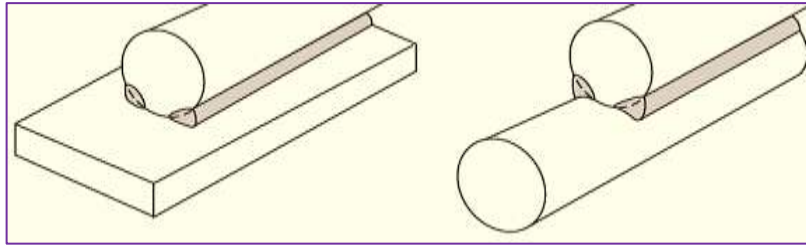

Double-J edge shape. A type of edge shape having two prepared surfaces adjacent to opposite sides of the material. **Double-J groove.** A double-sided weld groove formed by the combination of a butting member having a double-J edge shape abutting a planar surface of a companion member. **Double-J-groove weld.** A weld in a double-J groove welded from both sides. **Double-spliced butt joint.**

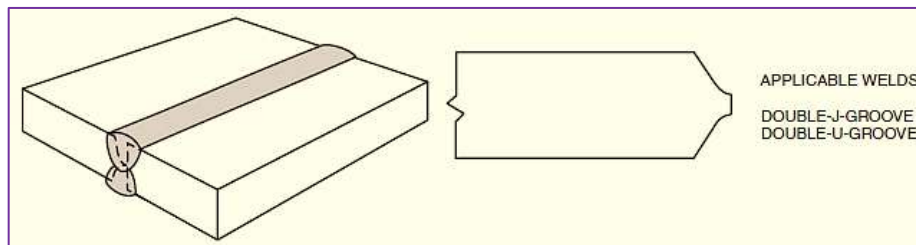

Double-square-groove weld. A weld in a square groove welded from both sides.

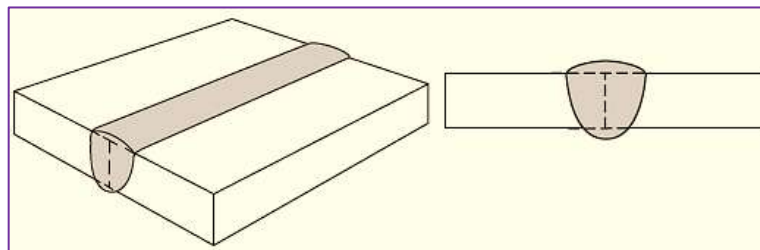

Double-U groove and Double-V groove. Double-U groove is a double-sided weld groove formed by the combination of butting members having double-J edge shapes. Double-U/V groove weld. Are welds in a double-U or V groove welded from both sides. Double-V groove. Is a double-sided weld groove formed by the combination of butting members having double bevel edge shapes.

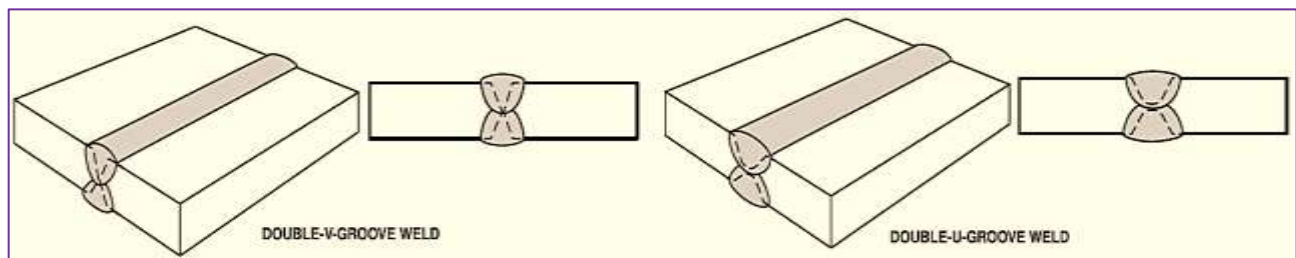

Dovetailing. A method of surface roughening involving angular undercutting to interlock the thermal spray deposit (*thermal spraying*).

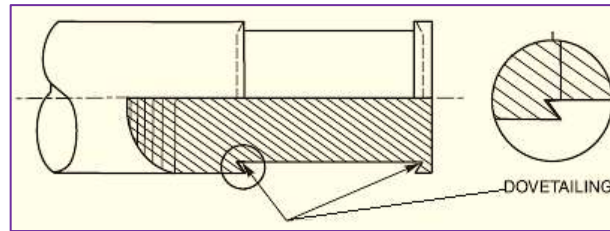

Downhill. Welding with a downward progression. Downhand. A nonstandard term used for flat welding position. Downslope time. See automatic arc welding downslope time and resistance welding.

Drag. The offset distance between the actual and straight line exit points of the gas stream or cutting beam measured on the exit surface of the base metal (*thermal cutting*).

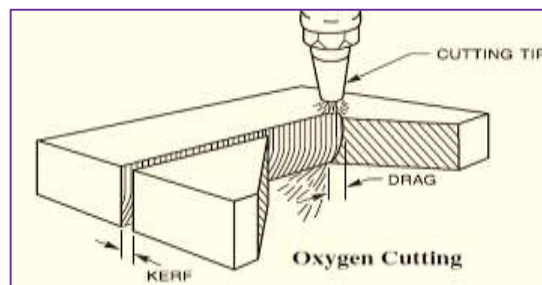

Drag angle. The travel angle when the electrode is pointing in a direction opposite to the progression of welding. This angle can also be used to partially define the position of guns, torches, rods, and beams. See backhand welding, push angle, travel angle, and work angle.

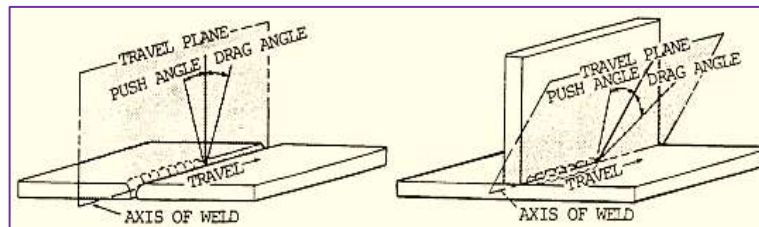

Drop-through. An undesirable sagging or surface irregularity, usually encountered when brazing or welding near the solidus of the base metal, caused by overheating with rapid diffusion or alloying between the filler metal and the base metal.

Dross. The remaining solidified, oxidized metallic material adhering to the workpiece adjacent to the cut surface (*thermal cutting*).

Drum. A cylindrical filler metal package used to contain a continuous length of wound or coiled filler metal wire.

Duty cycle. The percentage of time during a specified test period that a power source or its accessories can be operated at rated output without overheating. The test periods for arc welding and resistance welding are ten (10) minutes and one (1) minute, respectively.

Dwell time. The time during which the energy source pauses at any point in each oscillation (*welding*). The length of time that the surfacing material is exposed to the heat zone of the thermal spraying gun (*thermal spraying*).

E

Edge effect. Loosening of the bond between the thermal spray deposit and the substrate at the edge of the thermal spray deposit. Edge loss. Thermal spray deposit lost as overspray beyond the edge of the workpiece (*thermal spraying*).

Edge joint. A joint type in which the non-butting ends of one or more workpieces lie approximately parallel. Edge weld. A weld in an edge joint, a flanged butt joint or a flanged corner joint in which the full thickness of the members are fused.

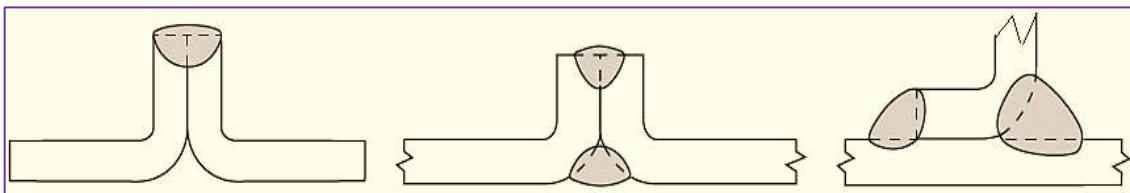

Edge preparation. The preparation of the edges of the joint members, by cutting, cleaning, plating, or other means. Edge shape. The shape of the edge of the joint member. See also skewed joint.

Effective throat. The minimum distance from the fillet weld face, minus any convexity, and the weld root. In the case of a fillet weld combined with a groove weld, the weld root of the groove weld shall be used. See concave and convex fillet weld.

Electrode. A component of the secondary circuit terminating at the arc, molten conductive slag, or base metal. See consumable electrode, cutting electrode, non-consumable electrode, resistance welding electrode, tungsten electrode, and welding electrode. Electrode adapter, *resistance welding*. A device used to adapt an electrode to an electrode holder. Electrode cap. A replaceable electrode adapter tip used for resistance spot welding. Electrode extension. The length of electrode extending beyond the electrode holder or cutting torch (*carbon arc cutting*). See constricted arc.

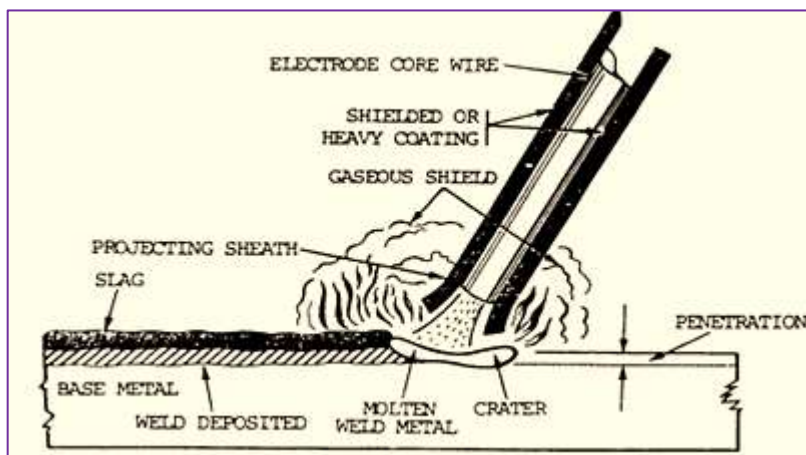

Electrode face. The surface of a resistance welding electrode that contacts the workpiece. Electrode holder. A device used for mechanically holding and conducting current to an electrode or electrode adapter (*resistance welding*). Electrode indentation. A depression formed on the surface of the workpiece by an electrode.

Electrode lead. A secondary circuit conductor transmitting energy from the power source to the electrode holder, gun, or torch. See direct current electrode.

Electrode life. The endurance of a welding electrode, normally expressed in terms of the number and/or length of welds produced between required servicing or replacement. Electrode mushrooming. The enlargement of the electrode face due to the heat and pressure of welding. Electrode pickup. Contamination of the electrode by the base metal or its coating during welding (*resistance welding*).

Electrode setback. The distance the electrode is recessed behind the constricting orifice of the plasma arc torch or thermal spraying gun, measured from the outer face of the constricting nozzle.

Electrode skid. A surface discontinuity resulting from electrode skidding. Electrode skidding. The transverse movement of the electrode with respect to the workpiece resulting from the application of electrode force (*resistance welding*). Electrode tip. A nonstandard term when used for electrode cap or electrode face.

Electrode Gas Welding (EGW). An arc welding process using an arc between a continuous filler metal electrode and the weld pool, employing approximately vertical welding progression with backing to confine the molten weld metal. The process is used with or without an externally supplied shielding gas and without the application of pressure.

Electron Beam Braze Welding (EBBW). A braze welding process variation employing a defocused or oscillating electron beam as the heat source. Electron Beam Brazing (EBB). A brazing process using heat from a slightly defocused or oscillating electron beam.

Electron Beam Cutting (EBC). A thermal cutting process severing metals by melting them with the heat from a concentrated beam, composed primarily of high-velocity electrons, impinging on the workpiece.

Electron beam gun. A device for producing and accelerating electrons. Typical components include the emitter (also called the *filament* or *cathode*) heated to produce electrons via thermionic emission, a cup (also called the grid or grid cup), and the anode. Electron beam gun column. The electron beam gun plus auxiliary mechanical and electrical components that may include beam alignment, focus, and deflection coils.

Electron Beam Welding (EBW). A welding process producing coalescence with a concentrated beam, composed primarily of high-velocity electrons, impinging on the joint. The process is used without shielding gas and without the application of pressure. See high vacuum electron beam welding, medium vacuum electron beam welding, and non-vacuum electron beam welding.

Electroslag electrode. A filler metal component of the welding circuit through which current is conducted from the electrode guiding member to the molten slag.

Electroslag Welding (ESW). A welding process producing coalescence of metals with molten slag, melting the filler metal and the surfaces of the workpieces. The weld pool is shielded by this slag, which moves along the full cross section of the joint as welding progresses. The process is initiated by an arc that heats the slag. The arc is then extinguished by the conductive slag, which is kept molten by its resistance to electric current passing between the electrode and the workpieces. See also electroslag welding electrode and consumable guide electroslag welding.

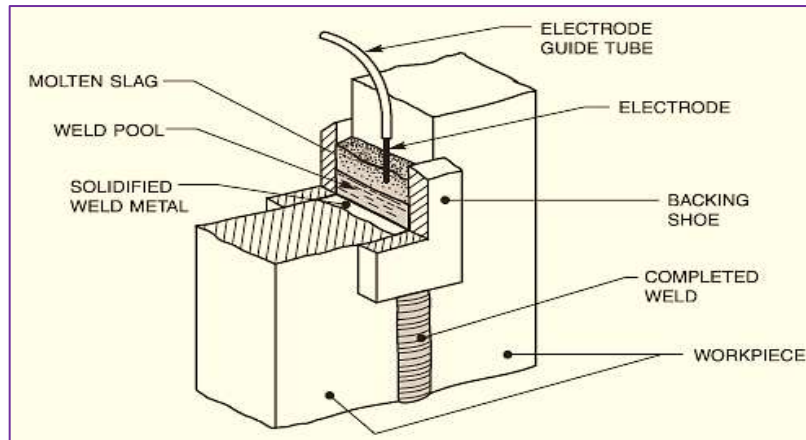

Elongated porosity. A form of porosity having a length greater than its width that lies approximately parallel to the weld axis.

Emissive electrode. A filler metal electrode consisting of a core of a bare electrode or a composite electrode to which a very light coating has been applied to produce a stable arc.

Erosion. The condition in which the base metal thickness has been reduced by dissolution (*brazing*).

Exothermic Braze Welding (EXBW). A braze welding process variation using an exothermic chemical reaction as heat source with the brazing filler metal provided as a reaction product. Exothermic Brazing (EXB). A brazing process using an exothermic chemical reaction as the heat source for the joint in which the brazing filler metal has been preplaced.

Explosion Welding (EXW). A solid-state welding process producing a weld by high velocity impact of the workpieces as the result of controlled detonation.

Expulsion. The ejection of molten metal during welding, either at the faying surface or the contact point(s) of the electrode face. Expulsion point. The amount of welding current above which expulsion occurs for a given set of welding conditions (*resistance welding*).

F

Face bend test. A test in which the weld face is on the convex surface of a specified bend radius.

Face feed. Manual or mechanical application of filler metal to the preheated joint. Face of the weld (*brazing and soldering*). Face reinforcement. Weld reinforcement on the side of the joint from which welding was done.

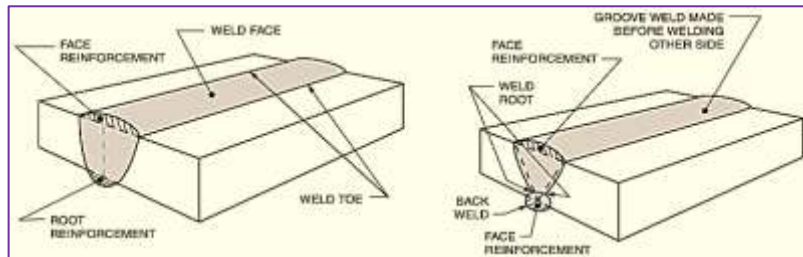

Face shield. A device positioned in front of the eyes and over all or a portion of the face to protect the eyes and face.

Faying surface. The mating surface of a workpiece in contact with or in close proximity to another workpiece to which it is to be joined.

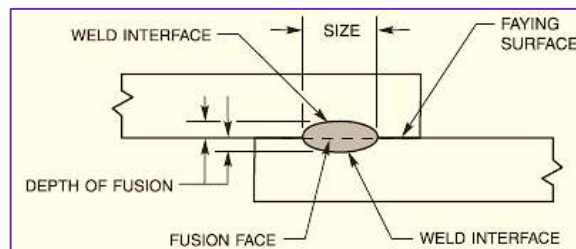

Ferrite Number (FN). An arbitrary, standardized value designating the ferrite content of an austenitic or duplex ferritic-austenitic stainless steel weld metal based on its magnetic properties. The term is always a proper noun and is always capitalized. Ferrite Number should not be confused with percent ferrite; the two are not equivalent.

Ferrule. A ceramic device surrounding the stud base to contain the molten metal and shield the arc (*arc stud welding*).

Field weld. A weld made at a location other than a shop or the place of initial construction. Fill bead. A nonstandard term when used for intermediate weld bead. Fill pass. A nonstandard term when used for intermediate weld pass. Fill weld. A fusion weld made with filler metal.

Filler material. The material to be added in making a brazed, soldered, or welded joint. Filler metal. The metal or alloy to be added in making a brazed, soldered, or welded joint. See brazing filler metal, consumable insert, diffusion aid, filler metal, solder, welding electrode, welding filler metal, welding rod, and welding wire.

Filler metal powder. Filler metal in particle form. Filler metal start delay time. The time interval from arc initiation to the start of filler metal feeding. Filler metal stop delay time. The time delay interval from beginning of downslope time to the stop of filler metal feeding.

Filler pass. A nonstandard term when used for intermediate weld pass. Filler wire. A nonstandard term for welding wire.

Fillet. The radius portion of the braze metal or solder metal adjacent to the joint. Fillet weld. A weld of approximately triangular cross section joining two surfaces approximately at right angles to each other in a lap joint, T-joint, or corner joint. See fillet weld leg.

Fillet weld break test. A test in which the specimen is loaded so that the weld root is in tension.

Fillet weld leg. The distance from the joint root to the toe of the fillet weld. Fillet weld size. For equal leg fillet welds, the leg lengths of the largest isosceles right triangle that can be inscribed within the fillet weld cross section. For unequal leg fillet welds, the leg lengths of the largest right triangle that can be inscribed within the fillet weld cross section.

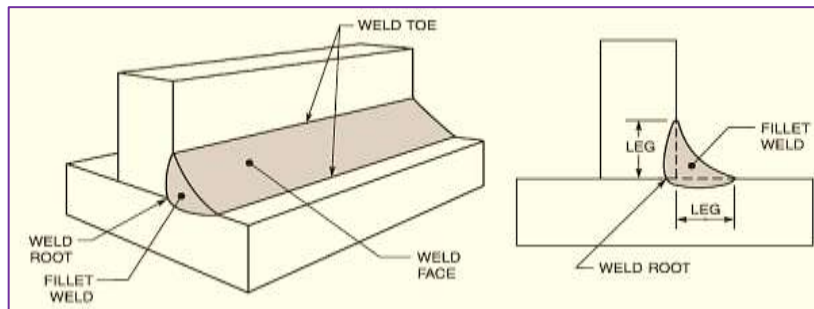

Filter plate. An optical material protecting the eyes against excessive ultraviolet, infrared, and visible radiation.

Final current. The current after downslope but prior to current shut-off. Final taper current. The current at the end of the taper interval prior to downslope.

Fines. Particles of flux or filler metal having a size smaller than a particular mesh size.

Fisheye. A discontinuity, attributed to the presence of hydrogen in the weld, observed on the fracture surface of a weld in steel consisting of a small pore or inclusion surrounded by an approximately round, bright area.

Fit-up. The as-fit joint geometry. Fixture. A device designed to maintain the fit workpiece(s) in the proper relationship.

Flame Spraying (FLSP). A thermal spraying process in which an oxyfuel gas flame is the source of heat for melting the surfacing material. Compressed gas may or may not be used for atomizing and propelling the surfacing material to the substrate.

Flanged butt joint. A form of a butt joint in which at least one of the members has a flanged edge shape at the joint. Flanged joint. A form of one of the five basic joint types in which at least one of the joint members has a flanged edge shape at the weld joint. Flanged corner joint. A form of a corner

joint in which the butting member has a flanged edge shape at the joint, and an edge weld is applicable. Flanged lap joint. A form of a lap joint in which at least one of the members has a flanged edge shape at the joint, and an edge weld is not applicable. See edge joint.

Flash coat. A thin metallic coating, usually less than 0.005 mm [0.0002 in] thick, applied to the workpiece(s) to promote joining (*brazing and soldering*). Flash time. Period of the flash welding cycle during which flashing action occurs.

Flash Welding (FW). A resistance welding process producing a weld at the faying surfaces of butting members by the rapid upsetting of the workpieces after a controlled period of flashing action.

Flashback. The recession of the flame through the torch and into the hose, regulator, and/or cylinder, potentially causing an explosion. Flashback arrester. A device to limit damage from a flashback by preventing propagation of the flame.

Flashing action. The phenomenon in flash welding wherein points on the faying surfaces are melted and explosively ejected. Flashover. Undesirable arcing occurring within the electron beam gun (*electron beam welding*).

Flat welding position. The welding position used to weld from the upper side of the joint at a point where the weld axis is approximately horizontal, and the weld face lies in an approximately horizontal plane. See welding positions.

Flaw. An undesirable discontinuity. See also defect.

Flow Brazing (FLB). A brazing process using heat from the brazing filler metal poured over the joint. This is an obsolete or seldom used process. See also flow welding and wave soldering. See Figures A.1 and A.6.

Flow brightening. Bonding of a soldering filler metal coating on a base metal to improve its finish. See also pre-coating (*soldering*).

Flowability. The ability of molten filler metal to be drawn into the joint or spread over the surface of the base material (*brazing and soldering*).

Flux. A material applied to the workpiece(s) before or during joining or surfacing to cause interactions that remove oxides and other contaminants, improve wetting, and affect the final surface profile. Welding flux may also affect the weld metal chemical composition. See also brazing flux, soldering flux, and welding flux. Flux coated rod. Brazing rod coated with flux (*brazing*).

Flux Cored Arc Welding (FCAW). An arc welding process using an arc between a continuous filler metal electrode and the weld pool. The process is used with shielding gas from a flux contained within the tubular electrode, with or without additional shielding from an externally supplied gas, and without the application of pressure. See also flux cored electrode, gas shielded flux cored arc welding, and self-shielded flux cored arc welding.

Flux cored electrode. A composite tubular filler metal electrode consisting of a metal sheath and a core of various powdered materials, producing a slag cover on the face of a weld bead. Flux cored soldering filler metal. Soldering filler rod or wire containing a flux.

Flux Cutting (OC-F). An oxygen cutting process using heat from an oxyfuel gas flame, with a flux in the flame to aid cutting. Flux oxygen cutting. A nonstandard term for flux cutting.

Forehand welding. A welding technique in which the welding torch or gun is directed toward the progress of welding. See push angle, travel angle, and work angle.

Forge Welding (FOW). A solid-state welding process producing a weld by heating the workpieces to the welding temperature and applying sufficient blows to cause permanent deformation at the faying surfaces. Forge force. A compressive force applied to the weld, causing plastic deformation.

Forge-delay time. The duration between a preselected point in the welding cycle and the initiation of the forging force (*resistance welding*).

Friction soldering. A nonstandard term for abrasion soldering. Friction upset distance. The decrease in length of workpieces during the time of friction welding force application. Friction speed. The relative velocity of the workpieces at the time of initial contact (*friction welding*).

Friction Stir Welding (FSW). A variation of friction welding producing a weld by the friction heating and plastic material displacement caused by a rapidly rotating tool traversing the weld joint.

Friction Welding (FRW). A solid-state welding process producing a weld under the compressive force contact of workpieces rotating or moving relative to one another to produce heat and plastically displace material from the faying surfaces. See also direct drive friction welding, friction stir welding, and inertia friction welding.

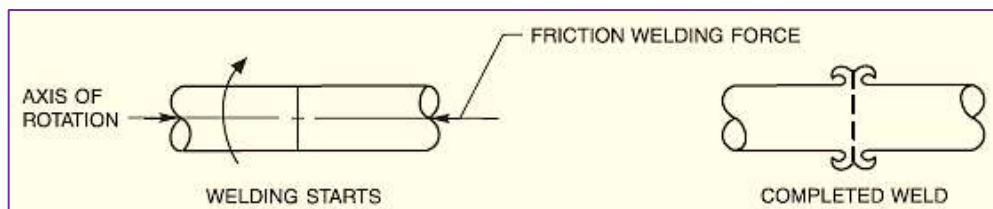

Fuel gas. A gas, when mixed with air or oxygen and ignited, producing heat for cutting, joining, or thermal spraying.

Furnace Brazing (FB). A brazing process in which assemblies are heated to the brazing temperature in a furnace. Furnace Soldering (FS). A soldering process using heat from a furnace or oven.

Fused flux. A granular flux produced by mixing the ingredients followed by melting, cooling to the solid state and processing to produce the desired particle size (*submerged arc welding*). Fused thermal spray deposit. A self-fluxing thermal spray deposit subsequently heated to coalescence within

itself and with the substrate using the spray fuse thermal spraying technique. Fused zone. A non-standard term for fusion zone.

Fusion. The melting together of filler metal and base metal, or of base metal only, to produce a weld (*fusion welding*). Fusion face. Surface of the base metal melted during welding. Fusion welding. Welding process using fusion of the base metal to make the weld. Fusion zone. The area of base metal melted as determined on the cross section of a weld.

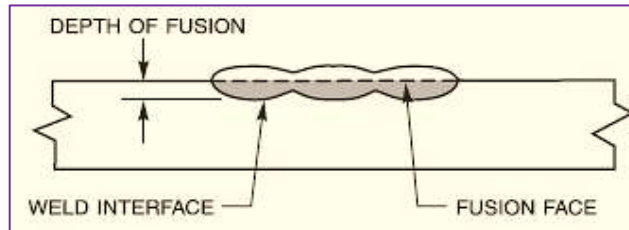

G

Gas Carbon Arc Welding (CAW-G). A carbon arc welding process variation employing a shielding gas. This is an obsolete or seldom used process.

Gas lens. One or more fine mesh screens located in the gas nozzle to produce a stable stream of shielding gas. This device is primarily used for gas tungsten arc welding.

Gas Metal Arc Cutting (GMAC). An arc cutting process employing a continuous consumable electrode and a shielding gas.

Gas Metal Arc Welding (GMAW). An arc welding process using an arc between a continuous filler metal electrode and the weld pool. The process is used with shielding from an externally supplied gas and without the application of pressure. See pulsed gas metal arc welding and short circuit gas metal arc welding. Gas nozzle. A device at the exit end of the torch or gun that directs shielding gas.

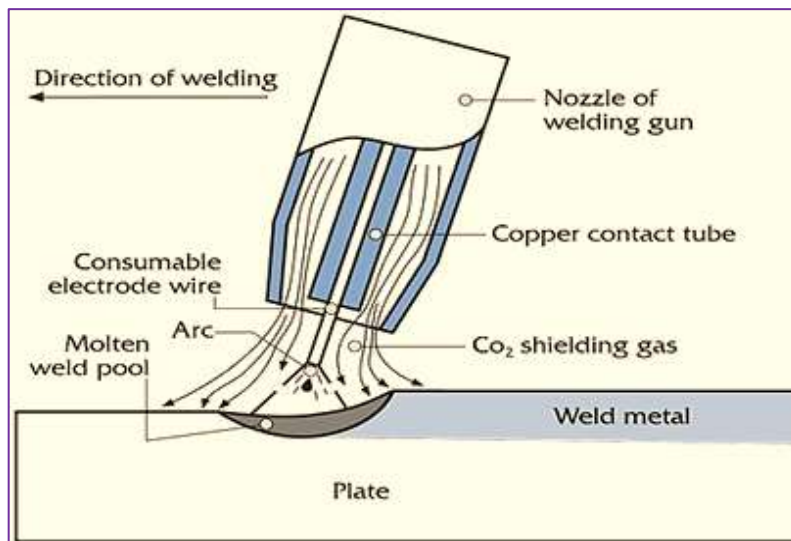

Gas pocket. A nonstandard term for porosity.

Gas regulator. A device for controlling the delivery of gas at some substantially constant pressure.

Gas Shielded Arc Welding (GSAW). A group of processes including electrogas welding, flux cored arc welding, gas metal arc welding, gas tungsten arc welding, and plasma arc welding.

Gas Shielded Flux-cored Arc Welding (FCAW-G). A flux cored arc welding process variation in which shielding gas is supplied through the gas nozzle in addition to that obtained from the flux within the electrode.

Gas Tungsten Arc Cutting (GTAC). An arc cutting process employing a single tungsten electrode with gas shielding. Gas tungsten arc cutting torch. A device used to transfer current to a fixed cutting electrode, position the electrode, and direct the flow of shielding gas.

Gas Tungsten Arc Welding (GTAW). An arc welding process using an arc between a tungsten electrode (non-consumable) and the weld pool. The process is used with shielding gas and without the application of pressure. See hot wire welding and pulsed gas tungsten arc welding. See Figure B.36.

Gas tungsten arc welding torch. A device used to transfer current to a fixed welding electrode, position the electrode, and direct the flow of shielding gas.

Getter. A material, such as hot titanium or zirconium, used to purify vacuum or inert gas atmospheres by absorbing or reacting with impurities.

Globular transfer. The transfer of molten metal in large drops from a consumable electrode across the arc. See short circuiting transfer and spray transfer (*gas metal arc welding*).

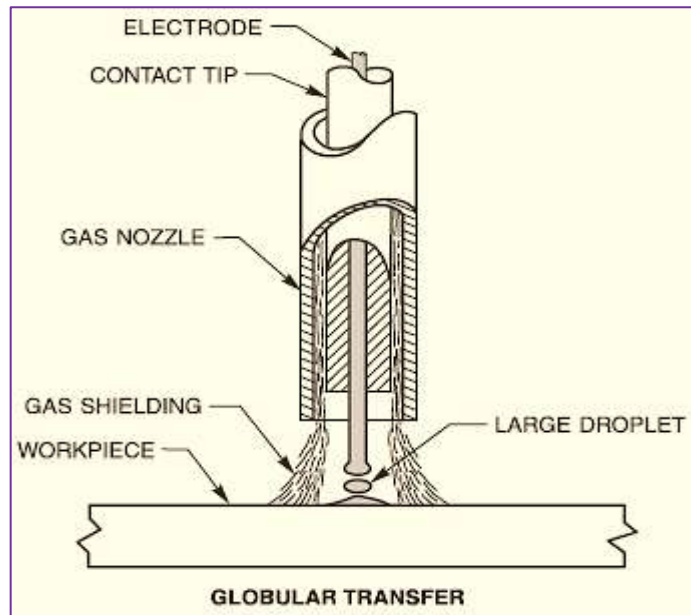

Goggles. Protective glasses equipped with filter plates set in a frame fitting snugly against the face and used primarily with oxyfuel gas processes.



Governing metal thickness. The workpiece thickness on which the required weld nugget size and depth of fusion are based (*resistance welding*).

Gradated thermal spray deposit. A composite thermal spray deposit composed of mixed materials in successive layers progressively changing in composition from the substrate to the surface of the thermal spray deposit.

Groove weld. A weld in a weld groove on a workpiece surface, between workpiece edges, workpiece surfaces, or between workpiece edges and surfaces. Groove angle. The included angle between the groove faces of a weld groove. Groove face. Any surface in a weld groove prior to welding.

Ground clamp. A nonstandard and incorrect term for workpiece connection. Ground connection. An electrical connection of the welding machine frame to the earth for safety. See direct current.

Gun extension. The extension tube attached in front of the thermal spraying gun to permit spraying within confined areas or deep recesses.

H

Hammer welding. A nonstandard term for cold welding and forge welding. Hammering. Excessive electrode impact on the surface of the workpiece during the welding cycle (*resistance spot welding*).

Hand shield. A protective device used in arc cutting, arc welding, and thermal spraying, for shielding the eyes, face, and neck. It is equipped with a filter plate and is designed to be held by hand.

Hard facing. A surfacing variation in which surfacing material is deposited to reduce wear. See also buildup, buttering, and cladding.

Heat balance. The various material, joint, and welding conditions determining the welding heat pattern in the joint. Heat pattern. The shape of the heat distribution in a material resulting from the application of heat.

Heat input. The energy applied to the workpiece during welding. Heat input rate. The heat input per unit length of weld. Heat time. The duration of any one impulse in multiple impulse welding or resistance seam welding.

Heat-Affected Zone (HAZ). The portion of base metal whose mechanical properties or microstructure have been altered by the heat of welding, brazing, soldering, or thermal cutting. Heat-affected zone crack. A crack occurring in the heat affected zone.

Heating pattern. A description of the manner in which some heat source is applied for joining, cutting, thermal spraying, preheating, post-heating, or thermal forming to produce a heat pattern. Heating gate. The opening in a thermite mold through which the workpieces are preheated. Heating torch. A device for directing the heating flame produced by the controlled combustion of fuel gases.

Hermetically sealed container. A container closed in a manner to provide a non-permeable barrier to the passage of air or gas in either direction.

High Energy Beam Cutting (HEBC). A group of thermal cutting processes severing or removing material by localized melting, burning or vaporizing of the workpieces using beams having high energy densities.

High Energy Beam Welding (HEBW). A group of welding processes using beams of energy with sufficient density to produce the coalescence of workpieces. The processes are applied with and without the application of pressure and with or without the application of filler metal.

High Vacuum Electron Beam Welding (EBW-HV). An electron beam welding process variation in which welding is accomplished at a pressure of 10^{-4} to 10^{-1} pascal [approximately 10^{-6} to 10^{-3} torr].

High Velocity Oxyfuel Spraying (HVOF). A thermal spraying process using a high pressure oxyfuel mixture to heat and propel a powdered surfacing material to a substrate.

High-Frequency Seam Welding (RSEW-HF). A resistance seam welding process variation in which welding current of at least 10 kHz is supplied through electrodes into the workpieces. High-frequency resistance welding. A group of resistance welding process variations using welding current of at least 10 kHz to concentrate the welding heat at the desired location.

High-Frequency Upset Welding (UW-HF). An upset welding process variation in which welding current of at least 10 kHz is supplied through electrodes into the workpieces.

Hold time. The duration of electrode force application at the end of the welding cycle to permit solidification of the weld (*projection welding, resistance seam welding, and resistance spot welding*).

Horizontal fixed position. A nonstandard term when used for multiple welding positions designated as 5G (*pipe*). Horizontal rolled position. A nonstandard term when used for the flat welding position designated as 1G (*pipe*).

Horizontal welding position. The welding position in which the weld is on the upper side of an approximately horizontal surface and against an approximately vertical surface (*fillet weld*). Horizontal welding position. The welding position in an approximately vertical plane and the weld axis at the point of welding is approximately horizontal (*groove weld*).

Hot crack. A crack occurring in a metal during solidification or at elevated temperatures. Hot cracks can occur in both heat-affected (HAZ) and weld metal zones (WMZ). See also cold crack.

Hot Isostatic Pressure Welding (HIPW). A diffusion welding process variation producing coalescence of metals by heating and applying hot inert gas under pressure.

Hot pass. A nonstandard term used for the weld pass subsequent to the root pass (*pipe*). Hot start current. A very brief current pulse at arc initiation to stabilize the arc quickly.

Hot Pressure Welding (HPW). A solid-state welding process producing a weld with heat and application of pressure sufficient to produce macro deformation of the workpieces. See also cold welding, diffusion welding, and forge welding.

Hot wire welding. A variation of a fusion welding process in which a filler metal wire is resistance heated by current flowing through the wire as it is fed into the weld pool.

Hybrid welding. The combination of two or more welding processes applied concurrently to produce a weld bead or nugget.

Impulse. A group of pulses occurring on a regular frequency separated only by an inter-pulse time.

Inclined position. A nonstandard term used for the multiple welding positions designated as 6G. Inclined position with restriction ring. A nonstandard term when used for the multiple welding positions designated as 6GR.

Inclusion. Entrapped foreign solid material, such as slag, flux, tungsten, or oxide.

Incomplete coalescence. A weld discontinuity in which complete joining of joint faying surfaces has not been achieved. Incomplete fusion. A weld discontinuity in which fusion did not occur between the weld metal and the fusion faces or the adjoining weld beads. See complete fusion.

Incomplete Joint Penetration (IJP). A joint root condition in a groove weld in which weld metal does not extend through the joint thickness. See complete joint penetration, complete joint penetration weld, joint penetration, and partial joint penetration weld.

Indirect welding. A secondary circuit variation in which the welding current is directed to the weld zone through the workpieces from application points away from the weld zone (*projection welding, resistance seam welding, and resistance spot welding*).

Induction Brazing (IB). A brazing process using heat from the resistance of the assembly to the induced electric current.

Induction coil. Electrical conductor transmitting high-frequency energy from an induction power source to a metallic workpiece to create localized heating. Induction power source. An electrical device used to convert line frequency into high frequency for induction heating.

Induction Seam Welding (RSEW-I). A resistance seam welding process variation in which high-frequency welding current is induced in the workpieces. See also high-frequency resistance welding and high-frequency seam welding.

Induction Soldering (IS). A soldering process in which the heat required is obtained from the resistance of the workpieces to induced electric current.

Induction Upset Welding (UW-I). An upset welding process variation in which high-frequency welding current is induced in the workpieces. See high-frequency resistance welding.

Induction Welding (IW). A resistance welding process variation in which heat results from the resistance of the workpieces to the flow of induced high-frequency welding current, with or without the application of pressure.

Inert gas. A gas that does not react chemically with materials. See also protective atmosphere.

Inertia Friction Welding (FRW-I). A variation of friction welding in which the energy required to make the weld is supplied primarily by the stored rotational kinetic energy of the welding machine. See also direct drive friction welding.

Infrared Brazing (IRB). A brazing process using heat from infrared radiation.

Infrared Soldering (IRS). A soldering process in which the heat required is furnished by infrared radiation. Infrared radiation. Electromagnetic energy with wave lengths from 770 nanometers to 12,000 nanometers [7,700 Å to 120,000 Å].

Insulating nozzle. A device at the exit end of the welding gun protecting the contact tip from spatter and possibly increasing the electrode extension while maintaining a shorter stick-out (*self-shielded flux cored arc welding*).

Intermediate flux. A soldering flux with a residue that generally does not attack the base metal. The original composition may be corrosive. Intermediate weld pass. A single progression of welding along a joint subsequent to the root pass(es) and prior to the cover pass(es). Intermediate weld bead. A weld bead resulting from an intermediate weld pass. Intermittent weld. A weld in which continuity is interrupted by recurring unwelded spaces.

Interpass temperature. In multipass thermal spraying, the temperature of the thermal spray area between thermal spray passes (*thermal spraying*). In a multipass weld, the temperature of the weld area between weld passes (*welding*).

Iron Soldering (INS). A soldering process obtained from a soldering iron.

J

Joining. Any process used for connecting materials. Joint. The junction of the workpiece(s) that are to be joined or have been joined. Joint type. A weld joint classification based on the relative orienta-

tion of the members being joined. The five basic joint types are the *butt*, *corner*, *edge*, *lap*, and *T-joints*. See edge joint.

Joint clearance. The distance between the faying surfaces of a joint (*brazing and soldering*). Joint design. The shape, dimensions, and configuration of the joint. Joint root. The portion of a joint to be welded where the members approach closest to each other. In cross section, the joint root may be a point, a line, or an area.

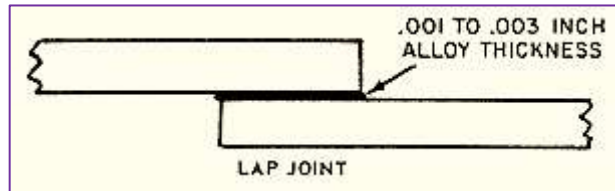

Joint filler. A metal plate inserted between the splice member and thinner joint member to accommodate joint members of dissimilar thickness in a spliced butt joint.

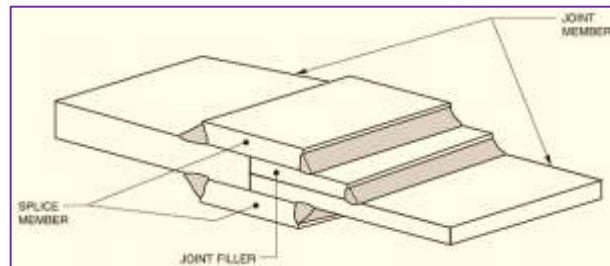

Joint geometry. The shape, dimensions, and configuration of a joint prior to joining. Joint opening. A nonstandard term for root opening. Joint penetration. The distance the weld metal extends from the weld face into a joint, exclusive of weld reinforcement. See groove weld size.

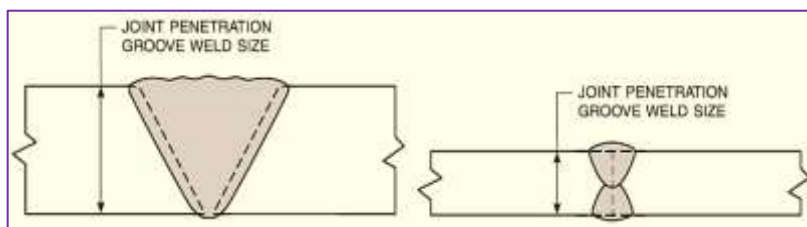

Joint recognition. A function of an adaptive control determining changes in joint geometry during welding and directing the welding equipment to take appropriate action. Joint tracking. A function of an adaptive control determining changes in joint location during welding and directing the welding machine to take appropriate action. See joint recognition and weld recognition.

Joint remelt temperature. The temperature to which a brazed or soldered joint must be raised in order to remelt the braze metal or solder metal. The joint remelt temperature may be higher than the original process temperature (*brazing and soldering*).

Joint spacer. Metal parts, such as a strip, bar, or ring, inserted in the joint root to serve as a backing and to maintain the root opening during welding.

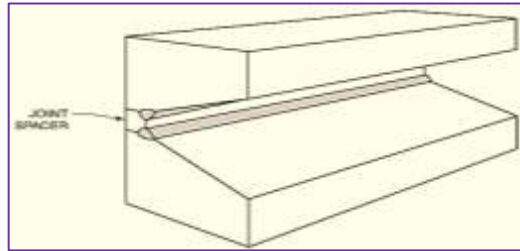

K

Kerf. The gap produced by a cutting process.

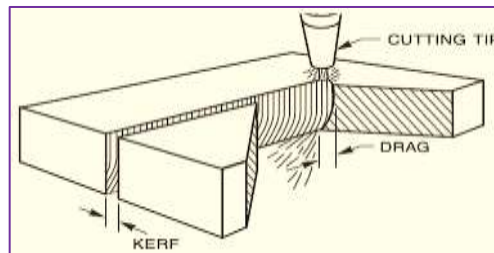

Keyhole welding. A technique in which a concentrated heat source penetrates partially or completely through a workpiece, forming a hole (keyhole) at the leading edge of the weld pool. As the heat source progresses, the molten metal fills in behind the hole to form the weld bead.

L

Lack of fusion. A nonstandard term for incomplete fusion. Lack of penetration. A nonstandard term for incomplete joint penetration.

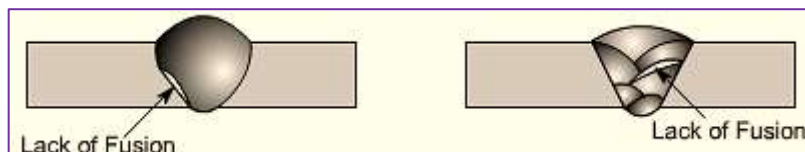

Lamellar tearing. A subsurface terrace and step-like crack in the base metal with a basic orientation parallel to the wrought surface caused by tensile stresses in the through-thickness direction of the base metals weakened by the presence of small dispersed, planar shaped, nonmetallic inclusions parallel to the metal surface.

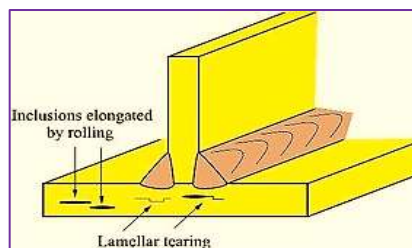

Lamination. A type of discontinuity with separation or weakness generally aligned parallel to the worked surface of a metal.

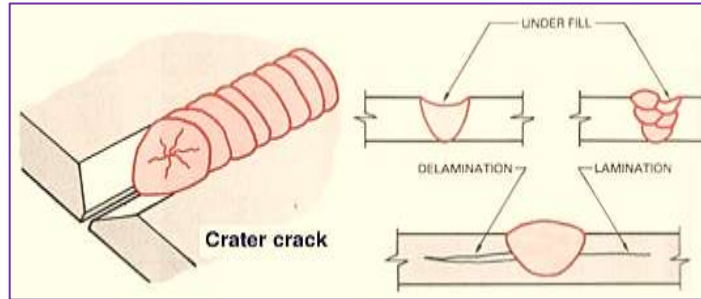

Lap joint. A joint type in which the non-butting ends of one or more workpieces overlap approximately parallel to one another. See also skewed joint.

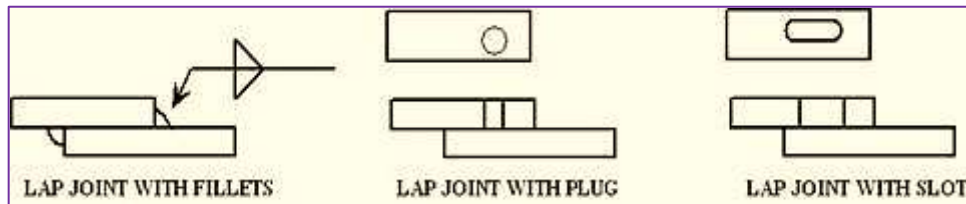

Laser. Is a complex equipment or a cutting device producing a concentrated coherent light beam by stimulated electronic or molecular transitions to lower energy levels. Laser is an acronym for “Light Amplification by Stimulated Emission of Radiation.”

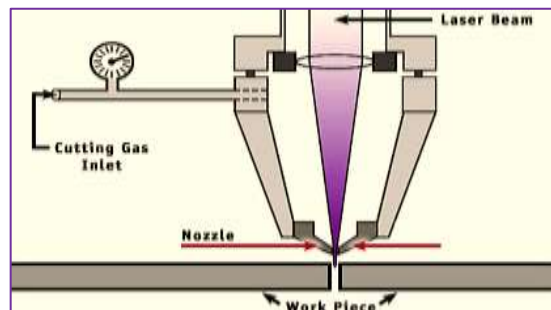

Laser Beam Air Cutting (LBC-A). A laser beam cutting process variation melting the workpiece and using an air jet to remove molten and vaporized material.

Laser Beam Braze Welding (LBBW). A braze welding process variation using a laser beam as the heat source.

Laser Beam Brazing (LBB). A brazing process using a laser beam as the heat source.

Laser Beam Cutting (LBC). A thermal cutting process severing metal by locally melting or vaporizing it with the heat from a laser beam. The process is used with or without assist gas to aid the removal of

molten and vaporized material. See laser beam air cutting, laser beam evaporative cutting, laser beam inert gas cutting, and laser beam oxygen cutting.

Laser beam diameter. The diameter of a laser beam circular cross section at a specified location along the laser beam axis. Laser beam expander. A combination of optical elements that will increase the diameter of a laser beam.

Laser Beam Evaporative Cutting (LBC-EV). A laser beam cutting process variation vaporizing the workpiece, with or without an assist gas, typically inert gas, to aid the removal of vaporized material.

Laser Beam Inert Gas Cutting (LBC-IG). A laser beam cutting process variation melting the workpiece and using an inert assist gas to remove molten and vaporized material.

Laser Beam Oxygen Cutting (LBC-O). A laser beam cutting process variation using heat from the chemical reaction between oxygen and the base metal at elevated temperatures. The necessary temperature is maintained with a laser beam.

Laser Beam Splitter. An optical device using controlled reflection to produce two beams from a single incident beam. Lasing gas. A gaseous lasing medium. Lasing medium. A material emitting coherent radiation by virtue of stimulated electronic or molecular transitions to lower energy.

Laser Beam Welding (LBW). A welding process producing coalescence with the heat from a laser beam impinging on the joint.

Linear discontinuity. A discontinuity with a length substantially greater than its width. Linear indication. A test result in which a discontinuity in the material being tested is displayed as a linear or aligned array. Linear porosity. A nonstandard term used for aligned porosity.

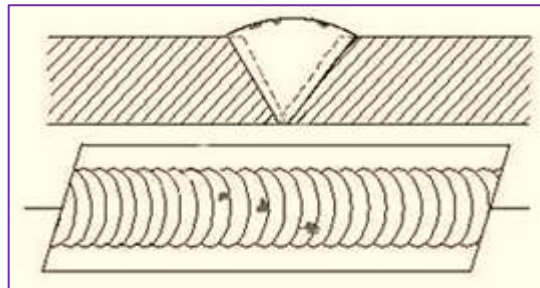

Liquation. The partial melting of compositional heterogeneities such as banding or inclusion stringers in heated base metal or heat-affected zones. Separation of a low-melting constituent of a brazing filler metal from the remaining constituents, usually apparent in brazing filler metals having a wide melting range (*brazing*). Liquidus. The lowest temperature at which a metal is completely liquid.

Local preheating. Preheating a specific portion of a structure. Local stress relief heat treatment. Stress relief heat treatment of a specific portion of a structure. Locked-up stress. A nonstandard term for residual stress.

Long electrode extension. An increased length of electrode extension for the purpose of increasing electrical resistance to assure enhanced flux activation to provide adequate shielding (FCAW-S) or increased weld deposition rate (*electrode gas welding, flux cored arc welding, gas metal arc welding, and submerged arc welding*).

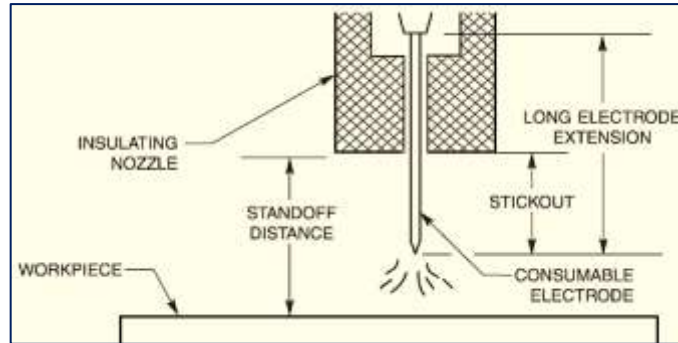

Longitudinal crack. A crack approximately parallel to the joint axis or the weld axis.

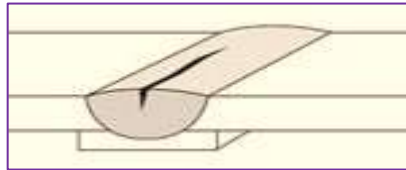

Longitudinal sequence. The order in which the weld passes of a continuous weld are made with respect to its length. See also backstep sequence, block sequence, cascade sequence, continuous sequence, and random sequence..

Longitudinal weld test specimen. Longitudinal tension specimen. A weld test specimen with its major axis parallel to the weld axis. See also transverse weld test specimen.

Low pulse current. The current during the low pulse time producing the low heat level. Low pulse time (*pulsed power welding*).

M

Macro etch test. A test in which a specimen is prepared with a fine finish, etched, and examined using no magnification or low magnification.

Macro-examination. A metallographic examination in which a surface is examined using no magnification or low magnification.

Magnetically Impelled Arc Welding (MIAW). An arc welding process in which an arc is created between the butted ends of tubes and propelled around the weld joint by a magnetic field, followed by an upsetting operation.

Manual process. Manual soldering (S-MA), manual thermal cutting (TC-MA), manual thermal spraying (TS-MA), manual welding (W-MA). An operation with the torch, gun, or electrode holder held and

manipulated by hand. Accessory equipment, such as part motion devices and handheld filler material feeders may be used. Variations of this term are manual brazing, manual soldering, manual thermal cutting, manual thermal spraying, and manual welding. See adaptive control process, automatic process, mechanized process, robotic, and semiautomatic process.

Mash Seam Welding (RSEW-MS). A resistance seam welding process variation producing a solid-state weld using electrodes extending beyond the joint overlap. The resulting joint thickness is less than the original assembled thickness.

Mask. A device for protecting a substrate surface from the effects of blasting or adherence of a thermal spray deposit (*thermal spraying*).

Mechanical bond. The adherence of a thermal spray deposit to a roughened surface by the mechanism of particle interlocking (*thermal spraying*).

Mechanically mixed flux. A flux produced by intentionally mixing two or more types of fluxes (*submerged arc welding*).

Mechanized process. Mechanized soldering (S-ME), mechanized thermal cutting (TC-ME), mechanized thermal spraying (TS-ME, mechanized welding (W-ME). An operation with equipment requiring manual adjustment by an operator in response to visual observation, with the torch, gun, wire guide assembly, or electrode holder held by a mechanical device. See mechanized brazing, mechanized soldering, mechanized thermal cutting, mechanized thermal spraying, and mechanized welding.

Medium Vacuum Electron Beam Welding (EBW-MV). An electron beam welding process variation in which welding is accomplished at a pressure of 10^{-1} pascal to 3×10^3 pascal (approximately 10^{-3} torr to 25 torr).

Melt-back time. Time intervals at the end of crater fill; time to arc outage during which electrode feed is stopped. Melt-in feed. A process in which filler metal is preplaced or continuously fed into the leading edge of the weld pool (*gas tungsten arc welding, oxyfuel gas welding and plasma arc welding*).

Melting range. The temperature range between solidus and liquidus. Melting rate. The weight or length of electrode, wire, rod, or powder melted in a unit of time. Melt-through. Visible root reinforcement in a joint welded from one side. See root reinforcement and root surface.

Metal-bath dip brazing. A dip brazing process variation in which the components to be joined are placed in a bath of molten brazing filler metal. See also chemical-bath dip brazing and salt-bath dip brazing. Metal-bath dip soldering. A dip soldering variation using heat from a bath of molten soldering filler metal. See oil-bath dip soldering and salt-bath dip soldering, wave soldering.

Metal cored electrode. A composite tubular filler electrode consisting of a metal sheath and a core of various powdered materials, producing no more than slag islands on the face of a weld bead. Metal electrode. A filler or non-filler metal electrode used in arc welding and cutting that consists of a metal wire or rod manufactured by any method and either bare or covered.

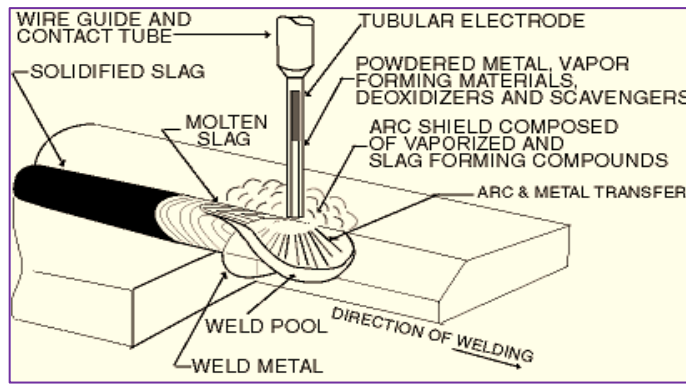

Metal Powder Cutting (OC-P). An oxygen cutting process using heat from an oxyfuel gas flame, with iron or other metal powder to aid cutting.

Metal transfer mode. The manner in which molten metal travels from the end of a consumable electrode across the welding arc to the workpiece. See globular transfer, pulsed spray transfer, rotational spray transfer, short circuiting transfer, and spray transfer (*gas metal arc welding*).

Metallizing. A nonstandard term when used for thermal spraying or the application of a metal coating. metallurgical bond. A nonstandard term for metallic bond. Metallic bond. The primary bond holding metals together, arising from the increased spacing of valence electrons when an aggregate of metal atoms are in close proximity. See bonding force, covalent bond, ionic bond, and mechanical bond.

Micro-etch test. A test in which the specimen is prepared with a polished finish, etched, and examined under high magnification. Micro-examination. A metallographic examination in which a prepared surface is examined at high magnification.

MIG welding. An usual nonstandard term used for Gas Metal Arc Welding (GMAW).

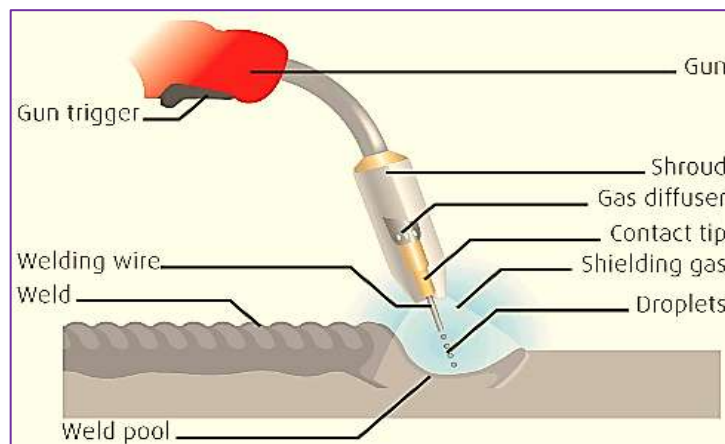

Mixed zone. The portion of the weld metal consisting of a mixture of base metal and filler metal. See also unmixed zone. Mixing chamber. The part of a welding or cutting torch in which a fuel gas and oxygen are mixed.

Multipass welding. A fusion weld produced by more than one progression of the arc, flame or energy source along the joint. Multiple-impulse welding. A resistance welding process variation in which welds are made by more than one impulse.

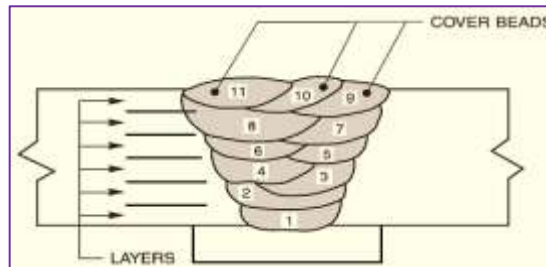

Multiport nozzle. A constricting nozzle of the plasma arc torch containing two or more orifices located in a configuration to achieve some control over the arc shape. See Mig welding.

N

Narrow groove welding. A variation of a welding process using multiple-pass welding with filler metal. The use of a small root opening, with either a square groove or a V-groove and a small groove angle, yields a weld with a high ratio of depth to width.

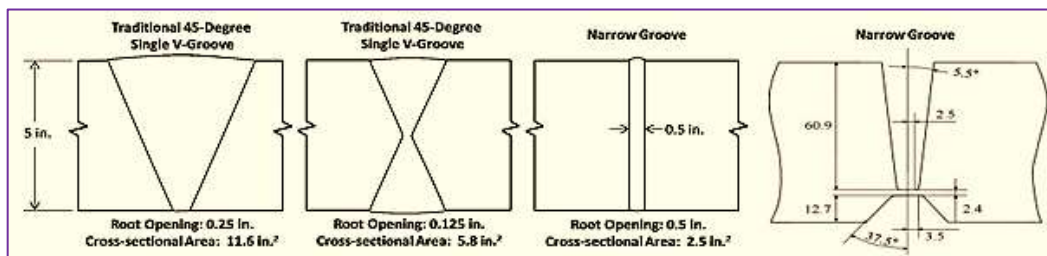

Neutral flame. An oxyfuel gas flame that is neither oxidizing nor reducing. See carburizing flame, oxidizing flame, and reducing flame. Neutral flux. A flux formulated to produce a weld metal composition that is not dependent on the welding parameters, especially arc voltage (*submerged arc welding*). See active flux and alloy flux.

Non-butting member. A joint member free to move in any direction perpendicular to its thickness dimension. For example, both members of a lap joint, or one member of a T-joint and corner joint.

Non-consumable electrode. An electrode without filler metal. See TIG Welding (GTAW).

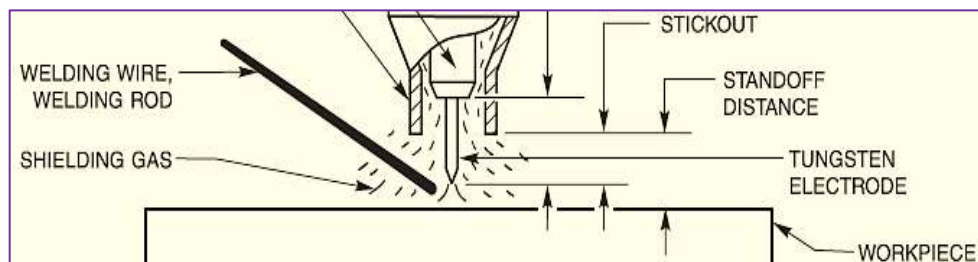

Noncorrosive flux. A flux in either its original or residual form that does not chemically attack the base metal (*brazing and soldering*).

Nondestructive Examination (NDE). The act of determining the suitability of a material or a component for its intended purpose using techniques not affecting its serviceability.

Non-Vacuum Electron Beam Welding (EBW-NV). An electron beam welding process variation in which welding is accomplished at atmospheric pressure.

Nozzle. A device at the exit end of the gun that directs the atomizing air or other gas (*arc spraying, flame spraying*). A device at the exit end of the gun that directs and forms the flow shape of atomized spray particles and the accompanying air or other gases. Nozzle accumulation. Filler metal or surfacing material deposited on the inner surface and on the exit end of the nozzle.

Nugget. The weld metal zone in a spot, seam, or projection weld. Nugget size. A nonstandard term used for projection weld size, resistance weld size, or seam weld size.

O

Oil-bath dip soldering. A dip soldering variation using heat from a bath of heated oil. See metal-bath dip soldering and salt-bath dip soldering.

Open butt joint. A nonstandard term when used for a butt joint with a root opening and with no backing. See open root joint. Open root joint. An unwelded joint without backing or consumable insert. Open circuit voltage. The voltage between the output terminals of power source when the rated primary voltage is applied and no current is flowing in the secondary circuit.

Orifice gas. The gas directed into the plasma arc torch or thermal spraying gun to surround the electrode. It becomes ionized in the arc to form the arc plasma and issues from the constricting orifice of the nozzle as a plasma jet. Orifice throat length. The length of the constricting orifice in the plasma arc torch or thermal spraying gun.

Oscillation. An alternating pattern of motion relative to the direction of travel in a welding, brazing, soldering, thermal cutting, or thermal spraying process device. See also weaving and whipping.

Overhead welding position. When welding is performed from the underside of the joint.

Overlap. The portion of the preceding weld nugget remelted by the succeeding weld. The protrusion of weld metal beyond the weld toe or weld root. Overlaying.

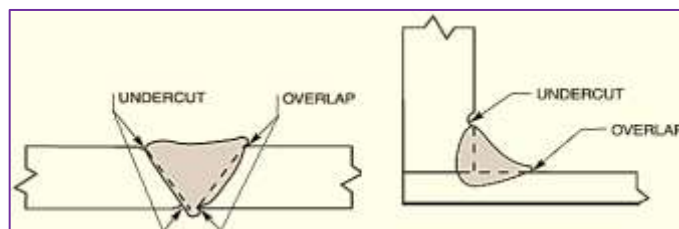

Overspray. The portion of the thermal spray deposit not deposited on the workpiece. Oxyfuel gas spraying. A nonstandard term for flame spraying.

Oxidizing flame. An oxyfuel gas flame in which there is an excess of oxygen, resulting in an oxygen-rich zone extending around and beyond the cone.. See carburizing, neutral and reducing flame.

Oxyacetylene Cutting (OFC-A). An oxyfuel gas cutting process employing acetylene as the fuel gas.

Oxyacetylene Welding (OAW). An oxyfuel gas welding process employing acetylene as the fuel gas. The process is used without the application of pressure.

Oxyfuel Gas Cutting (OFC). A group of oxygen cutting processes using heat from an oxyfuel gas flame. See also oxyacetylene cutting, oxyhydrogen cutting, oxynatural gas cutting, and oxypropane cutting. Oxyfuel gas cutter. One who performs oxyfuel gas cutting.

Oxyfuel gas cutting torch. A device used for directing the preheating flame produced by the controlled combustion of fuel gases and to direct and control the cutting oxygen. Oxyfuel gas welding torch. A device used in oxyfuel gas welding, torch brazing, and torch soldering for directing the heating flame produced by the controlled combustion of fuel gases.

Oxyfuel Gas Welding (OFW). A group of welding processes producing coalescence of workpieces by heating them with an oxyfuel gas flame. The processes are used with or without the application of pressure and with or without filler metal.

Oxygen Arc Cutting (OAC). An oxygen cutting process using an arc between the workpiece and a consumable tubular electrode through which oxygen is directed to the workpiece.

Oxygen Cutting (OC). A group of thermal cutting processes severing or removing metal by means of the chemical reaction between oxygen and the base metal at elevated temperature. The necessary temperature is maintained by the heat from an arc, an oxyfuel gas flame, or another source.

Oxygen Gouging (OG). Thermal gouging using an oxygen cutting process variation to form a bevel or groove. Oxygen grooving. A nonstandard term for oxygen gouging.

Oxygen Lance Cutting (OLC). An oxygen cutting process employing oxygen supplied through a consumable lance. Preheat to start the cutting is obtained by other means. Oxygen lance. A length of pipe used to convey oxygen to the point of cutting in oxygen lance cutting.

Oxyhydrogen Cutting (OFC-H). An oxyfuel gas cutting process employing hydrogen as the fuel gas.

Oxyhydrogen Welding (OHW). An oxyfuel gas welding process employing hydrogen as the fuel gas. The process is used without the application of pressure.

Oxynatural Gas Cutting (OFC-N). An oxyfuel gas cutting process supplied through natural gas as the fuel gas.

Oxypropane Cutting (OFC-P). An oxyfuel gas cutting process variation employing propane as the fuel gas.

P

Parallel welding. A secondary circuit variation in which the welding current is conducted through the workpieces in parallel electrical paths to form multiple resistance spot, seam, or projection welds simultaneously. Parallel gap welding. A nonstandard term when used for series welding with closely spaced electrodes.

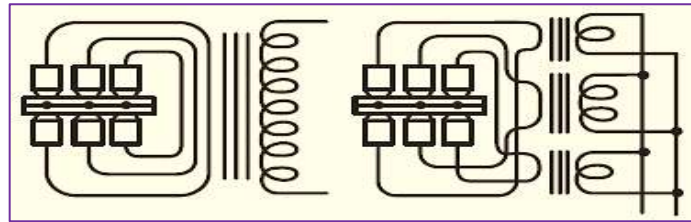

Partial joint penetration weld. A groove weld with an incomplete joint penetration. Parent metal. A nonstandard term for base metal or substrate.

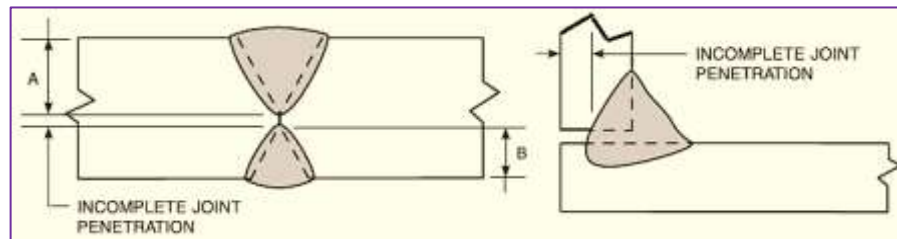

Paste braze. Used for brazing filler metal paste. Paste brazing filler metal. Used for brazing filler metal paste. Paste solder. Used for soldering filler metal paste. Paste soldering filler metal. Used for soldering filler metal paste.

Peel test. A destructive testing method mechanically separating a lap joint by peeling. Peening. The mechanical working of metals using impact blows.

Penetration-enhancing flux. A material applied to the base metal surface adjacent to the weld joint prior to gas tungsten arc welding resulting in increased weld penetration (*gas tungsten arc welding*).

Percussion Welding (PEW). A welding process producing coalescence with an arc resulting from a rapid discharge of electrical energy. Pressure is applied percussively during or immediately following the electrical discharge.

Pilot arc. A low current arc between the electrode and the constricting nozzle of the plasma arc torch to ionize the gas and facilitate the start of the welding arc.

Piping porosity. A form of porosity having a length greater than its width that lies approximately perpendicular to the weld face.

Plasma Arc Cutting (PAC). An arc cutting process employing a constricted arc and removing molten metal with a high-velocity jet of ionized gas issuing from the constricting orifice. Plasma arc cutting torch. Used to transfer current to a fixed cutting electrode, position the electrode, and direct the flow of shielding gas and orifice gas. Plasma arc welding torch. Used to transfer current to a fixed welding electrode, position the electrode, and direct the flow of shielding gas and orifice gas.

Plasma Arc Gouging (PAG). A thermal gouging process using heat from a constricted arc and the force of an orifice gas. See also carbon arc gouging and oxygen gouging.

Plasma Arc Welding (PAW). An arc welding process employing a constricted arc between a non-consumable electrode and the weld pool (transferred arc) or between the electrode and the constricting nozzle (non-transferred arc). Shielding is obtained from the ionized gas issuing from the torch, which may be supplemented by an auxiliary source of shielding gas. The process is used without the application of pressure. See also hot wire welding.

Plasma Spraying (PSP). A thermal spraying process in which a non-transferred arc is used to create an arc plasma for melting and propelling the surfacing material to the substrate. See also vacuum plasma spraying.

Plenum chamber. The space between the electrode and the inside wall of the constricting nozzle of the plasma arc torch or thermal spraying gun.

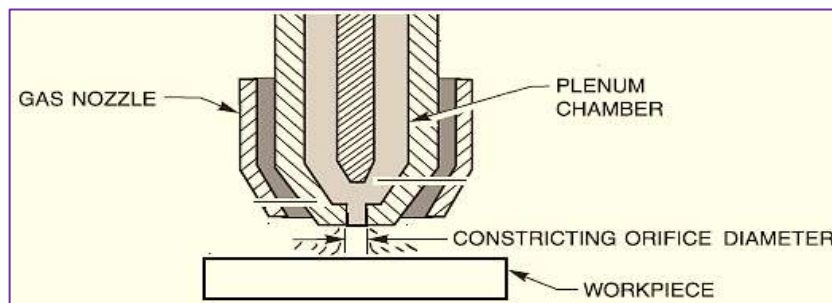

Plug (slot) weld. A weld made in a circular hole in one member of a joint fusing that member to another member. Plug weld size. The diameter of the weld metal in the plane of the faying surfaces.

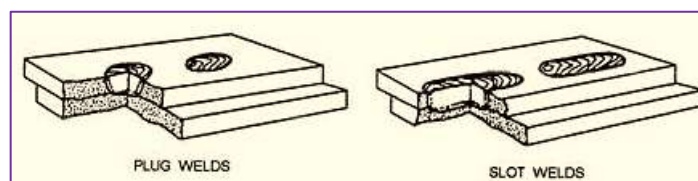

Polarity. Direct current electrode negative and direct current electrode positive. Direct Current Electrode Negative (DCEN). Direct Current Electrode Positive (DCEP).

Portable gun. A nonstandard term when used for a manual gun. Portable transgun. A term used for a manual transgun (*resistance welding*). Positional usability. A measure of the relative ease of application of a welding filler metal to make a sound weld in a given welding position and progression.

Post-heating. The application of heat to an assembly after brazing, soldering, thermal spraying, thermal cutting, or welding. Post-weld interval. The duration from the end of the weld interval through the hold time (*resistance welding*).

Powder composite. Two or more different materials combined to form a single particle, formed by either chemical coating or mechanical agglomeration. Powder blend. A mixture of two or more alloy, metal, or nonmetal powders. Powder cutting. For flux cutting and metal powder cutting.

Powder flame spraying. A flame spraying process variation in which the surfacing material is in powder form. See flame spraying.

Power source. An apparatus for supplying current and voltage suitable for welding, thermal cutting, or thermal spraying. Power supply. Used for power source.

Poke welding. A nonstandard term for push welding. Push angle. The travel angle when the electrode is pointing in the direction of weld progression. This angle can also be used to partially define the position of guns, torches, rods, and beams. See drag angle, forehand welding, travel angle, and work angle.

Pre-coating. The application of a filler metal to components prior to assembly and joining (*brazing and soldering*). See flow brightening.

Preheat. The heat applied to the workpiece(s) to keep and maintain the preheat temperature prior to welding, thermal cutting, or thermal spraying. Preheat, *v.* Is the act of applying heat to the workpiece(s) before welding, cutting or spraying. Pre-weld interval. The elapsed time between the initiation of the squeeze time and the beginning of the weld time or weld interval time.

Preheat temperature. The temperature of the base material in the volume surrounding the point of welding immediately before welding is started. In a multipass weld, it is also the temperature immediately before the second and subsequent passes are started. Preheat current. An impulse or impulses occurring prior to and separated from the welding current.

Prequalified Welding Procedure Specification (PWPS). A welding procedure specification in compliance with the stipulated conditions of a particular welding code or specification and therefore acceptable for use under that code or specification without a requirement for qualification testing.

Pressure Gas Welding (PGW). An oxyfuel gas welding process producing a weld simultaneously over the entire faying surfaces. The process is used with the application of pressure and without filler metal. Pressure welding. A nonstandard term when used for cold welding, diffusion welding, forge welding, hot pressure welding, pressure gas welding, and solid state welding.

Pressure-Controlled Resistance Welding (RW-PC). A resistance welding process variation in which a number of spot or projection welds are made with several electrodes functioning progressively under the control of a pressure-sequencing device.

Procedure. The detailed elements of a process or method used to produce a specific result. Procedure qualification. The demonstration that the use of prescribed joining processes, materials, and techniques will result in a joint exhibiting specified soundness and mechanical properties.

Procedure Qualification Record (PQR). See brazing procedure qualification record and welding procedure qualification record.

Projection Welding (PW). A resistance welding process in which the weld size, shape, and placement is determined by the presence of a projection, embossment, or intersection in one overlapping member which serves to localize the applied heat and force. Projection weld size. The nugget dimension(s) in the plane of the faying surfaces. See cross wire welding.

Protective atmosphere. A gas or vacuum envelope present during joining, thermal cutting, or thermal spraying used to prevent or reduce the formation of oxides and other detrimental surface substances and facilitate their removal. See also backing gas, inert gas, reducing atmosphere, and shielding gas.

Pulsed Gas Metal Arc Welding (GMAW-P). A gas metal arc welding process variation in which the current is pulsed. See also pulsed power welding.

Pulsed Gas Tungsten Arc Welding (GTAW-P). A gas tungsten arc welding process variation in which the current is pulsed. See also pulsed power welding.

Pulsed power welding. An arc welding process variation in which the welding power source is programmed to cycle between low and high power levels. Pulsed laser. A laser whose output is controlled to produce a pulse whose duration is 25 milliseconds or less.

Pulsed spray transfer. A variation of spray transfer in which the welding power is cycled from a low level to a high level, at which point spray transfer is attained, resulting in a lower average voltage and current. See globular transfer, short circuiting transfer, and spray transfer.

Purge. The inlet gas to remove contaminants from a system or provide backing during welding.

Q

Quench time. The duration from the end of the weld interval or downslope time to the beginning of the temper time, during which no current flows through the workpieces and the weld is rapidly cooled by the electrodes.

R

Random intermittent welds. Intermittent welds on one or both sides of a joint in which the weld segments are made without regard to spacing. Random sequence. A longitudinal sequence in which the weld bead segments are made at random.

Reactor. A device used in arc welding circuits to minimize irregularities in the flow of the welding current. Reaction soldering. A soldering process variation in which a reactive flux is used. Reaction

stress. A stress that cannot exist in a member if the member is isolated as a free body without connection to other parts of the structure.

Reactive flux. Flux containing constituents reacting with the workpiece(s) during heating to contribute filler metal (*soldering*).

Reconditioned flux. Virgin or recycled flux processed for use or reuse. The processing may include screening for particle sizing, removal of magnetic particles and baking to remove moisture (*submerged arc welding*).

Recycled flux. Unfused granular flux remaining after welding that has been recovered for reuse (*submerged arc welding*). Recycled slag. Fused slag remaining after welding that has been recovered and processed for reuse. Re-crushed slag. Used for recycled slag. See virgin flux.

Reducing atmosphere. A type of protective atmosphere that dissociates metal oxides at elevated temperatures. Reducing flame. An oxyfuel gas flame with an excess of fuel gas.

Resistance Brazing (RB). A brazing process using heat from the resistance to the electric current flow in a circuit that includes the assembly.

Resistance Seam Welding (RSEW). A resistance welding process producing a weld at the faying surfaces of overlapped parts progressively along a length of a joint. The weld may be made with overlapping weld nuggets, a continuous weld nugget, or by forging the joint as it is heated to the welding temperature by resistance to the flow of the welding current. See high-frequency seam welding and induction seam welding.

Resistance Soldering (RS). A soldering process using heat from the resistance to the flow of electric current in a circuit containing the workpiece(s).

Resistance Spot Welding (RSW). A resistance welding process producing a spot weld.

Resistance Welding (RW). A group of welding processes producing coalescence of the faying surfaces with the heat obtained from the resistance of the workpieces to the flow of the welding current in a circuit of which the workpieces form part and by the application of pressure.

Resistance welding electrode. The part of a secondary circuit responsible for the transmission of welding current and force to the workpieces. The electrode may be in the form of a rotating wheel, rotating roll, bar, cylinder, plate or clamp.



Resistance welding gun. A device used to apply electrode force and transfer welding current to the workpieces. It may be manipulated or an element of a welding machine. See manual gun, manual transgun, servo gun, and robot gun.



Robotics. Process control with equipment that moves along a controlled path using controlled parameters with no manual intervention once a cycle is initiated. See adaptive control, automatic, manual, mechanized, and semiautomatic.

Robotic process. Robotic brazing (B-RO), robotic soldering (S-RO), robotic thermal cutting (TC-RO), robotic thermal spraying (TS-RO), robotic welding (W-RO). See robotic brazing, robotic soldering, robotic thermal cutting, robotic thermal spraying, and robotic welding, adaptive control process, automatic process, manual process, mechanized process, and semiautomatic process.

Roll Welding (ROW). A solid-state welding process producing a weld by the application of heat and sufficient pressure with rolls to cause deformation at the faying surfaces. Roll spot welding. A resistance seam welding process variation producing spot welds at intervals using one or more circular electrodes that are rotated continuously or intermittently. See also forge welding.

Root opening. A separation at the joint root between the workpieces. Root gap. A term for root opening. Root pass. A weld pass made to produce a root bead.

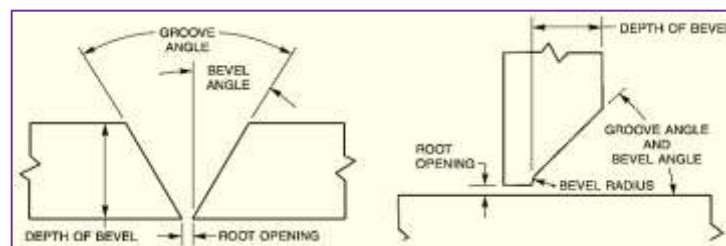

Root penetration. The distance the weld metal extends into the joint root. Root radius. A term for bevel radius. Root reinforcement. Weld reinforcement opposite the side from which welding was done. Root surface. The exposed surface of a weld opposite the side from which welding was done.

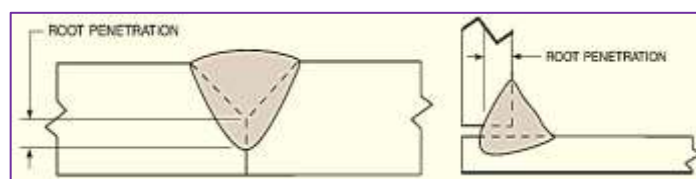

S

Salt-bath dip brazing. A variation of chemical-bath dip brazing using heat from a molten salt bath. See also metal-bath dip brazing. Salt-bath dip soldering. A dip soldering variation using heat from a molten salt bath. See metal-bath dip soldering and oil-bath dip soldering.

Scarf groove. A groove formed by the assembly of butting members having single-bevel edge shapes with parallel groove faces. Scarf joint. A term for scarf groove.

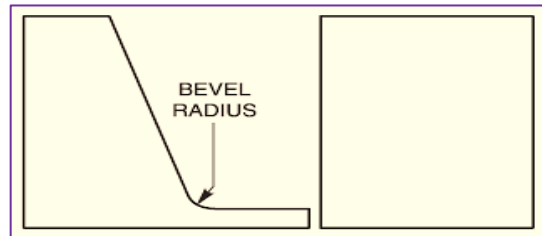

Seam welding. A continuous weld produced between overlapping members with coalescence initiating and occurring at faying surfaces proceeding from the outer surface of one member. The weld can consist of a weld bead, multiple overlapping nuggets, or a single nugget formed by the simultaneous application of resistance heating and forging force along the weld joint. Seam weld size. The nugget width in the plane of the faying surfaces.

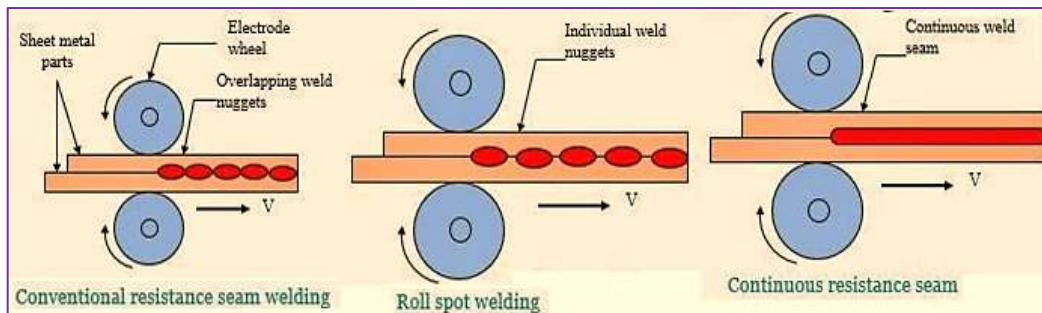

Seal welding. Any weld intended primarily to provide a specific degree of tightness against leakage. Seal-bonding material. A material partially forming, a metallic bond with the substrate.

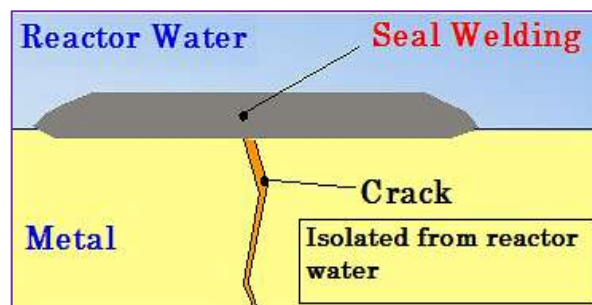

Self-Shielded Flux Cored Arc Welding (FCAW-S). A flux cored arc welding process variation in which shielding gas is obtained exclusively from the flux within the electrode.

Semiautomatic process. Semiautomatic brazing (B-SA), semiautomatic soldering (S-SA), semiautomatic thermal cutting (TC-SA), semiautomatic thermal spraying (TS-SA), semiautomatic welding (W-SA). An operation performed manually with equipment controlling one or more of the process conditions. See semiautomatic brazing, semiautomatic soldering, semiautomatic thermal cutting, semiautomatic thermal spraying, semiautomatic welding, automatic process and robotic process.

Series Submerged Arc Welding (SAW-S). A submerged arc welding process variation in which the arc is established between two consumable electrodes meeting just above the surface of the workpieces, which are not part of the welding current circuit.

Series welding. A resistance welding secondary circuit variation in which the welding current is conducted through electrodes and workpieces in a series electrical path to form multiple resistance, spot, seam, or projection welds simultaneously. See parallel welding.

Shielded Carbon Arc Welding (CAW-S). A carbon arc welding process variation using shielding from the combustion of solid material fed into the arc, or from a blanket of flux on the workpieces, or both. This is an obsolete or seldom used process.

Shielded Metal Arc Cutting (SMAC). An arc cutting process employing a covered electrode.

Shielded Metal Arc Welding (SMAW). An arc welding process with an arc between a covered electrode and the weld pool. The process is used with shielding from the decomposition of the electrode covering, without the application of pressure, and with filler metal from the electrode. See also fire-cracker welding.

Short Circuit Gas Metal Arc Welding (GMAW-S). A gas metal arc welding process variation in which the consumable electrode is deposited during repeated short circuits. Shielding gas. A gas used to produce a protective atmosphere. See backing gas and inert gas.

Shrinkage stress. Residual stress resulting from the contraction of materials upon cooling from joining, thermal cutting, or thermal spraying. Shrinkage void. A cavity-type discontinuity formed as a metal contracts during solidification.

Silver alloy brazing. A nonstandard term when used for brazing with a silver-based brazing filler metal silver soldering. An incorrect term for brazing or soldering with a silver-containing filler metal.

Single-bevel edge shape. A type of bevel edge shape having one prepared surface. Single-bevel groove weld. A weld groove formed by the combination of a butting member having a bevel edge shape and a planar surface of a companion member or a butting member with a square edge shape and a skewed surface of a non-butting member. See single groove weld.

Single-groove weld. Single-flare-V-groove weld. A weld in a single-flare-V groove welded from one side. A groove weld made from one side only. **Single-J groove.** A weld groove formed by the combination of a butting member having a single-J edge shape abutting a planar surface of a companion member. **Single-J-groove weld.** A weld in a single-J groove welded from one side. **Single-U groove.**

A weld groove formed by the combination of two butting members having single-J edge shapes. **Single-U-groove weld.** A weld in a single-U groove welded from one side. **Single-V groove.** A V-shaped weld groove formed by the combination of (a) butting members having single bevel edge shapes, (b) butting and non-butting members having planar surfaces arranged to form a groove, or (c) a V-shaped groove in the surface of a member. **Single-V-groove weld.** A weld in a single-V groove welded from one side.

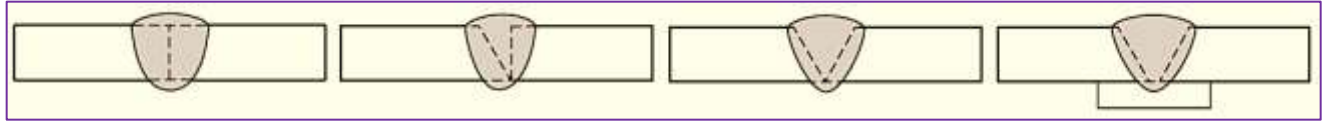

Skewed joint. A variation of any one of the five basic joint types in which the members are oriented at angles different than the typical orthogonal angles. See skewed butt joint, skewed corner joint, skewed edge joint, skewed lap joint, and skewed T-joint.

Skull. The unmelted residue from a filler metal resulting from either incomplete melting or an inadequate protective atmosphere (*brazing and soldering*).

Slag. A nonmetallic product resulting from the mutual dissolution of flux and nonmetallic impurities in some welding and brazing processes. Slag inclusion. A discontinuity consisting of slag entrapped in weld metal or at the weld interface.

Slugging. The unauthorized addition of metal, such as a length of rod, to a joint before welding or between passes, often resulting in a weld with incomplete fusion.

Smoothing bead. A weld bead made to correct an undesirable weld surface contour. See also cosmetic weld bead. Smoothing pass. A weld pass resulting in a smoothing bead.

Solder. A bond produced as a result of heating an assembly to the soldering temperature using a soldering filler metal distributed and retained between the closely fitted faying surfaces of the joint by capillary action. Soldering. A group of joining processes in which the workpiece(s) and solder are heated to the soldering temperature to form a soldered joint.

Soldering filler metal. The metal or alloy to be added in making a soldered joint. The filler metal has a liquidus below 450°C (840°F). Soldering filler metal paste. Paste consisting of a filler metal powder, a flux, and a neutral carrier. Soldering flux. A flux used for soldering.

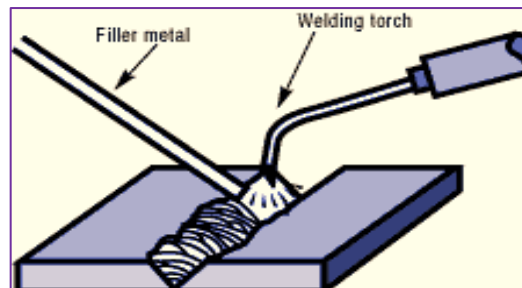

Soldering gun. An electrically heated soldering iron with a pistol grip. Soldering iron. A tool for manual soldering used to heat the workpiece(s) by thermal conduction from the tip, which is heated by internal electrical resistance or external flame.

Solid-State Welding (SSW). A group of welding processes producing coalescence by the application of pressure without melting any of the joint components.

Solidus. The highest temperature at which a metal is completely solid.

Spiking. A condition where the joint penetration is non-uniform and changes abruptly over the length of the weld (*electron beam welding and laser beam welding*).

Spliced joint. A joint in which an additional workpiece spans the joint welded to each joint member. Splice. A nonstandard term used for a brazed, soldered or welded joint. Splice member. The workpiece spanning the joint in a spliced joint. See spliced joint.

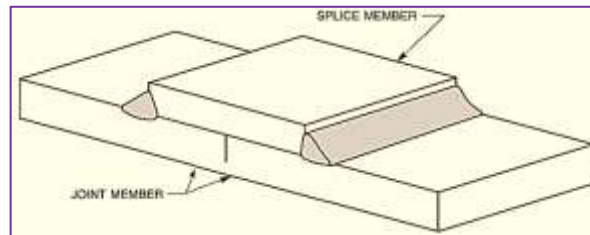

Split layer technique. A welding technique resulting in layers having more than one weld bead. Split pipe backing. A pipe segment used as a backing for welding butt joints in round bars.

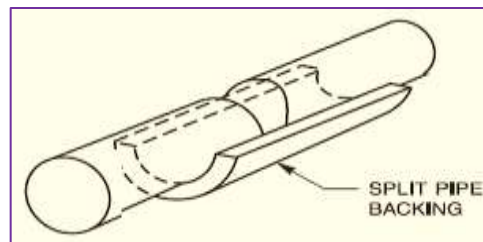

Spool. A filler metal packaging configuration in which the wire is wound around a cylinder (called a barrel), which is flanged at both ends. The flanges contain a spindle hole centered inside the barrel. See Figure B.42(A). See also coil without support and coil with support.

Spray arc. A nonstandard term for spray transfer. Spray deposit. See thermal spray deposit. Spray deposit density ratio. See thermal spray deposit density ratio.

Spray-fuse. A thermal spraying technique in which the deposit is reheated to fuse the particles and form a metallurgical bond with the substrate.

Spraying rate. The rate at which surfacing material passes through the gun. Spraying sequence. Layers of materials that are applied, such as overlapped, superimposed, or at various angles.

Spray transfer. Metal transfer in which molten metal from a consumable electrode is propelled axially across the arc in small droplets (*gas metal arc welding*). See globular and short circuiting transfer.

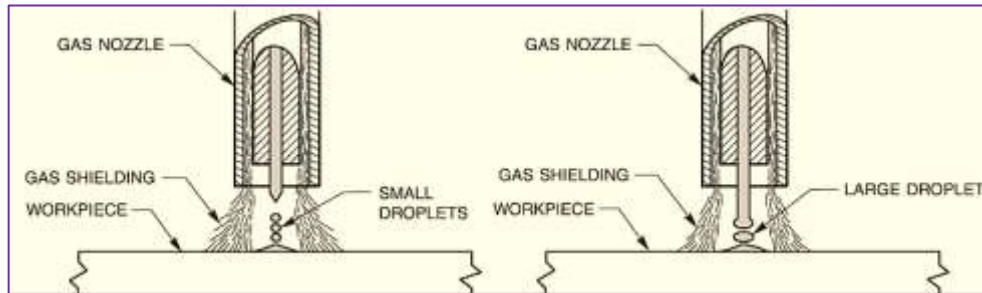

Square groove weld. A weld groove formed by the combination of a butting member having a square edge shape and a planar surface of a companion member. Square edge shape. A type of edge shape in which the prepared surface lies perpendicular to the material surface. See edge joint.

Staggered intermittent weld. An intermittent weld on both sides of a joint in which the weld segments on one side are alternated with respect to those on the other side.

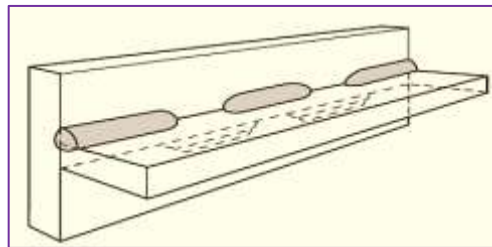

Standard Welding Procedure Specification (SWPS). A welding procedure specification qualified according to the requirements of AWS B2.1, approved by AWS, and made available for production welding by companies or individuals other than those performing the qualification test.

Standoff distance. The distance between a nozzle and the workpiece. See long electrode extension.

Starting weld tab. Additional material extending beyond the beginning of the joint, on which the weld is started. See also runoff weld tab and weld tab.

Stationary shoe. A backing shoe remaining in a fixed position during welding. See also moving shoe.

Stick electrode. A nonstandard term for covered electrode. Stick electrode welding. A nonstandard term for shielded metal arc welding.

Stick-out. The length of unmelted electrode extending beyond the end of the gas nozzle. See electrode extension (*gas metal arc welding and gas-shielded flux cored arc welding*). Stick-out, gas. The length of tungsten electrode extending beyond the end of the gas nozzle. See long electrode extension (*tungsten arc welding*).

Stored energy welding. A resistance welding process variation in which the welding current is produced from electrical energy that is accumulated electrostatically, electromagnetically, or electrochemically at allow rate and released at a relatively high rate. Straight polarity. Term for direct current electrode negative.

Stranded electrode. A composite filler metal electrode consisting of stranded wires that may mechanically enclose materials to improve properties, stabilize the arc, or provide shielding.

Stress-corrosion cracking. Failure of metals by cracking under the combined actions of corrosion and stress, residual or applied. In brazing, the term applies to the cracking of stressed base metal due to the presence of a liquid filler metal.

Stress-relief cracking. Intergranular cracking in the heat-affected zone or weld metal as a result of the combined action of residual stresses and postweld exposure to an elevated temperature. Stress-relief heat treatment. Uniform heating of a structure or a portion thereof to a sufficient temperature to relieve the major portion of the residual stresses, followed by uniform cooling.

Stringer bead. A weld bead formed without appreciable weaving. See weave bead.

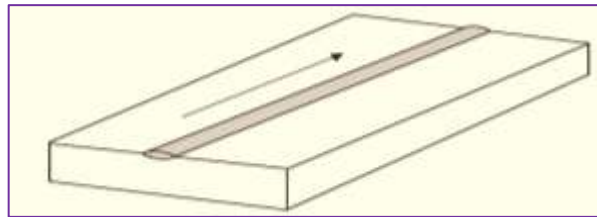

Strong-back. A device attached to the members of a weld joint to maintain alignment during welding.

Stub. The short length of filler metal electrode, welding rod, or brazing rod remaining after its use for welding or brazing.

Stud welding. A general term for joining a metal stud or similar part to a workpiece. Welding may be accomplished by arc, resistance, friction, or other process with or without external gas shielding. See also arc stud welding.

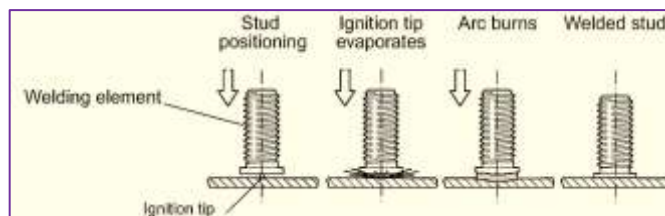

Submerged Arc Welding (SAW). An arc welding process using an arc or arcs between a bare metal electrode or electrodes and the weld pool. The arc and molten metal are shielded by a blanket of granular flux on the workpieces. The process is used without pressure and with filler metal from the

electrode and sometimes from a supplemental source (welding rod, flux, or metal granules). See also hot wire welding and series submerged arc welding.

Substrate. A workpiece onto which a coating is applied.

Suck-back. A nonstandard term used for underfill at the root surface. Surface expulsion. Expulsion occurring between the electrode and the workpiece.

Surface preparation. The operations necessary to produce a desired or specified surface condition. Surface roughening. A group of methods for producing irregularities on a surface.

Surfacing weld. Weld applied to a surface, to obtain desired abrasion properties or chemical erosion resistance. Surfacing metal. Metal or alloy applied to a base metal or substrate during surfacing.

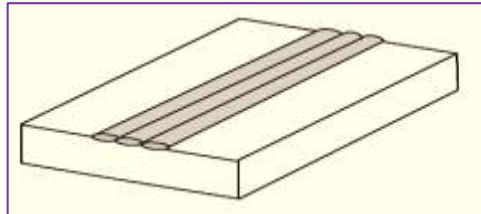

Susceptor. An inductively heated component positioned near a joint to aid in heating.

Sustained backfire. The recession of the flame into the torch body with continued burning characterized by an initial popping sound followed by a squealing or hissing sound, potentially burning through the torch body. See also backfire and flashback.

Sweat soldering. A nonstandard term for soldering. Sweating. A nonstandard term for soldering.

T

Tack weld. A weld made to hold the parts of a weldment in proper alignment until the final welds are made. Tack welder. One who performs manual or semiautomatic welding to produce tack welds.

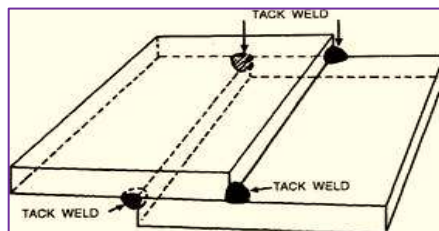

Tap. A nonstandard term used for transformer tap.

Taper delay time. The time interval after upslope during which the maximum welding current or high pulse current is constant. Taper time. The time interval when current increases or decreases continuously from the welding current to final taper current.

Temporary weld. A weld made to attach a piece or pieces to a weldment for temporary use in handling, shipping, or working on the weldment.

Tension test. A test in which a specimen is loaded in tension until failure occurs. See also reduced section test specimen.

Test coupon. A weldment, brazement, or solderment used for procedure or performance qualification testing. Test specimen. A sample of a test coupon subjected to testing.

Theoretical throat. The distance from the beginning of the joint root perpendicular to the hypotenuse of the largest right triangle that can be inscribed within the cross section of a fillet weld. This dimension is based on the assumption that the root opening is equal to zero. See also effective throat.

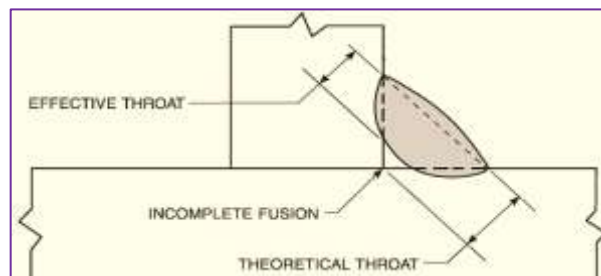

Thermal Cutting (TC). A group of cutting processes severing or removing metal by localized melting, burning, or vaporizing of the workpieces. See also arc cutting, high energy beam cutting, and oxygen cutting.

Thermal Gouging (TG). A thermal cutting process removing metal by melting or burning the entire removed portion, to form a bevel or groove. See arc gouging, back-gouging, and oxygen gouging.

Thermal spray deposit. The coating or layer of surfacing material applied by a thermal spraying process. Thermal spray deposit density ratio. The ratio of the density of the thermal spray deposit to the theoretical density of the surfacing material, usually expressed as percent of theoretical density.

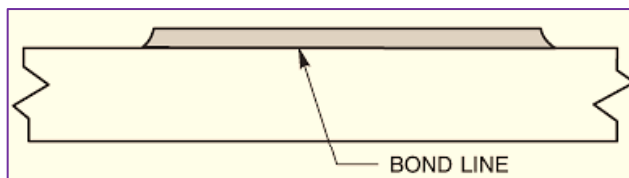

Thermal Spraying (THSP). A group of processes in which finely divided metallic or nonmetallic surfacing materials are deposited in a molten or semi-molten condition on a substrate to form a thermal spray deposit. The surfacing material may be in the form of powder, rod, cord, or wire. See also arc spraying, flame spraying, and plasma spraying.

Thermal stress. Stress in a material or assembly resulting from non-uniform temperature distribution or differential thermal expansion.

Thermite crucible. The vessel in which the thermite reaction takes place. Thermite mixture. A mixture of metal oxide and finely divided aluminum with the addition of alloying metals as required. Thermite mold. A mold formed around the workpieces to receive molten metal. Thermite reaction. The chemical reaction between metal oxide and aluminum producing superheated molten metal and a slag containing aluminum oxide.



Thermite Welding (TW). Also known as exothermic welding is a welding process producing coalescence of metals by heating them with superheated liquid metal from a chemical reaction between a metal oxide and aluminum, with or without the application of pressure. It employs an exothermic reaction of a thermite composition to heat the metal, and requires no external source of heat or current.

Throat area. The region bounded by the physical components of the secondary circuit of a welding machine. Throat crack. A crack in the throat of a fillet weld. Throat depth. The distance from the centerline of the electrodes or platens to the nearest point of interference for flat sheets. Throat height. The minimum distance between the arms of the welding machine throughout the throat area.

Tie-in. The junction of weld metal and base metal or prior weld metal where fusion is intended. Tie-in (v). To manipulate the welding process at the junction of the weld metal and base metal.

TIG welding. A nonstandard term for Gas Tungsten Arc Welding (GTAW).

T-joint. A joint type in which the butting end of a workpiece is aligned approximately perpendicular with either its surface or the surface of a non-butting workpiece. See also skewed joint.

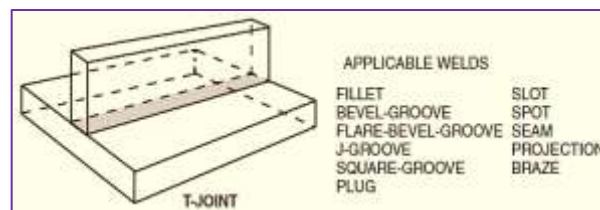

Torch. See air carbon arc cutting torch, gas tungsten arc cutting torch, gas tungsten arc welding torch, heating torch, oxyfuel gas cutting torch, oxyfuel gas welding torch, plasma arc cutting torch, and plasma arc welding torch. Torch tip. See cutting tip and welding tip.

Transferred arc. A plasma arc established between the electrode of the plasma arc torch and the workpiece. See also non transferred arc.

Transformer tap. Connections to a transformer winding used to vary the transformer turns ratio, thereby controlling welding voltage and current.

Transgun. A resistance welding gun with an integral, closely coupled resistance welding transformer. transverse bend specimen. See transverse weld test specimen.

Transverse weld test specimen. A weld test specimen with its major axis perpendicular to the weld axis. See also longitudinal weld test specimen.

Travel angle. The angle less than 90° between the electrode axis and a line perpendicular to the weld axis, in a plane determined by the electrode axis and the weld axis. This angle can also be used to partially define the position of guns, torches, rods, and beams. See push angle and work angle.

Tubular joint. A joint between two or more members, at least one of which is tubular.

Tungsten electrode. Non-filler metal electrode used in arc welding, arc cutting, and plasma spraying, made principally of tungsten. Tungsten inclusion. Discontinuity of tungsten entrapped in weld metal.

Twin Carbon Arc Brazing (TCAB). A brazing process using heat from an arc between two carbon electrodes. This is an obsolete or seldom used process.

Twin Carbon Arc Welding (CAW-T). A carbon arc welding process variation using an arc between two carbon electrodes and no shielding. This is an obsolete or seldom used process.

U

Ultrasonic coupler. Elements through which ultrasonic vibration is transmitted from the transducer to the tip (*ultrasonic soldering and ultrasonic welding*).

Ultrasonic Soldering (USS). A soldering process variation in which high-frequency vibratory energy is transmitted through molten solder to remove undesirable surface films and thereby promote wetting of the base metal. This operation is usually accomplished without flux.

Ultrasonic Welding (USW). A solid-state welding process producing a weld by the local application of high-frequency vibratory energy as the workpieces are held together under pressure.

Under-bead crack. A heat-affected zone arising from the occurrence of a crack microstructure, residual or applied stress, and the presence of hydrogen. Undercut. A groove melted into the base metal adjacent to the weld toe or weld root and left unfilled by weld metal. See crack and crater.

Underfill. A groove weld condition in which the weld face or root surface is below the adjacent surface of the base metal. Unfused flux. Flux not melted during welding.

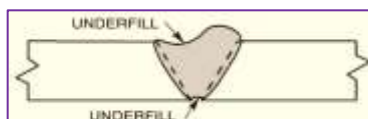

Unmixed zone. A thin boundary layer of weld metal, adjacent to the weld interface, solidified without mixing with the remaining weld metal. See also mixed zone.

Uphill. Welding with an upward progression.

Upset. Deformation of a workpiece due the application of pressure, increase in transverse section area, reduction in length, reduction in thickness, or reduction of the cross wire weld stack height.

Upset Welding (UW). A resistance welding process producing a weld over the entire area of faying surfaces or progressively along a butt joint. See high-frequency upset and induction upset welding.

V

Vacuum brazing. A nonstandard term for various brazing processes taking place in a chamber or retort below atmospheric pressure.

Vacuum Plasma Spraying (VPSP). A thermal spraying process variation using a plasma spraying gun confined to a stable enclosure that is partially evacuated.

Vertical welding position. The welding position in which the weld axis, at the point of welding, is approximately vertical and the weld face lies in an approximately vertical plane. Vertical position. A nonstandard term when used for the pipe welding test position designated as 2G (*pipe welding*). Vertical-down. A nonstandard term for downhill. Vertical-up. A nonstandard term for uphill.

Voltage regulator. An automatic electrical control device for maintaining a constant voltage supply to the primary of a welding transformer.

W

Wash pass. A nonstandard term used for a cosmetic weld pass, cover pass, or smoothing pass.

Waster plate. A carbon steel plate placed on an alloy workpiece at the torch side to provide the necessary iron to facilitate cutting of the alloy workpiece (*oxyfuel gas cutting*).

Wave Soldering (WS). A soldering process using heat from a bath of filler metal in which the filler metal is flowed against the joint by an induced wave action. See also dip soldering.

Wax pattern. Wax molded around workpieces to the desired completed weld (*thermite welding*).

Weaving. A welding technique in which the thermal source is oscillated transversely as it progresses along the weld path. Weave bead. A weld bead formed using weaving. See also stringer bead.

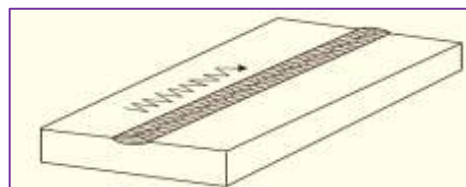

Weld. A localized coalescence of metals or nonmetals produced either by heating the materials to the welding temperature, with or without the application of pressure, or by the application of pressure alone and with or without the use of filler material. Weld, *v.* The act of welding.

Weld bead. A weld resulting from a weld pass. Weld axis. A line through the length of the weld, perpendicular to and at the geometric center of its cross section. See weld layers.

Weld bonding. A welding process variation in which the weld strength is augmented by adhesive at the faying surfaces. Weld brazing. Brazing using heat from a welding process such that the preplaced brazing filler metal is melted to form a braze augmenting the weld by increasing joint strength or creating a seal between spot or intermittent welds.

Weld crack. A crack located in the weld metal or heat-affected zone. See crack and crater.

Weld dam. A metallic or nonmetallic object placed at the end of a weld groove to contain the molten metal and facilitate complete cross-sectional filling of the weld groove. A nonstandard term when used for backing shoe. See also weld tab.

Weld groove. A channel in the surface of a workpiece or an opening between two joint members providing space to contain weld metal.

Weld interface. The boundary between weld metal and base metal in a fusion weld, between base metals in a solid-state weld without filler metal, or between filler metal and base metal in a solid-state weld with filler metal. Weld face. The exposed surface of a weld on the side from which welding was done. Weld gauge. A device designed for measuring the shape and size of welds.

Weld interval. Heat and cool times to produce a multiple-impulse weld. See also weld time.

Weld Layer. A stratum of weld metal consisting of one or more welds beads.

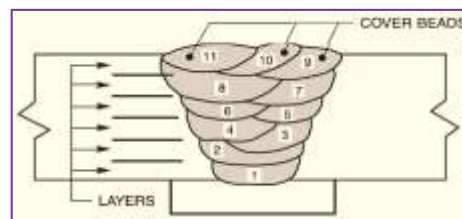

Weld metal. Metal in a fusion weld consisting of that portion of the base metal and filler metal melted during welding. Weld metal crack. A crack occurring in the weld metal zone.

Weld Metal Zone (WMZ). The portion of the weld area consisting of weld metal. See also base metal zone and heat-affected zone.

Weld pass. A single progression of welding along a joint. The result of a weld pass is a weld bead or layer. Weld pass sequence. The order in which the weld passes is made. Weld penetration. A non-

standard term for joint penetration or root penetration. Weld seam. A nonstandard term for joint, seam weld, weld, or weld joint.

Weld pool. The localized volume of molten metal in a weld, prior to its solidification as weld metal. Weld puddle. A nonstandard term for weld pool.

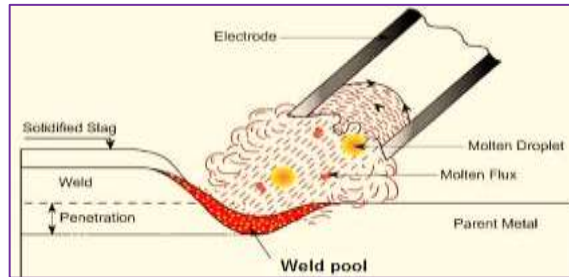

Weld porosity. Cavity-type discontinuities formed by gas entrapment during solidification or in a thermal spray deposit.

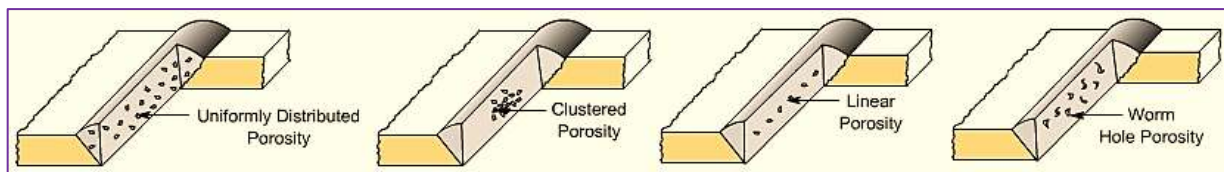

Weld reinforcement. Weld metal in excess of the quantity required to fill a weld groove. See also convexity, face reinforcement, and root reinforcement.

Weld root. The points, shown in cross section, at which the weld metal intersects the base metal and extends furthest into the weld joint. Weld size. See edge weld size, fillet weld size, groove weld size, plug weld size, projection weld size, seam weld size, slot weld size, and spot weld size. Weld toe. The junction of the weld face and the base metal.

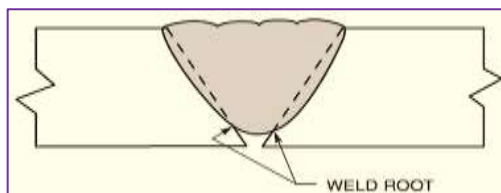

Weld spatter. The metal particles expelled during fusion welding that do not form a part of the weld. Spatter loss. Metal lost due to spatter.

Weld symbol. A graphic character connected to the reference line of a brazing or welding symbol specifying the joint geometry or weld type.

Weld tab. Additional material extending beyond either end of the joint, on which the weld is started or terminated.

Weld toe. The root of the weld is the part of deepest penetration which is the opposite angle of the hypotenuse. The toes of the weld are essentially the edges or the points of the hypotenuse.

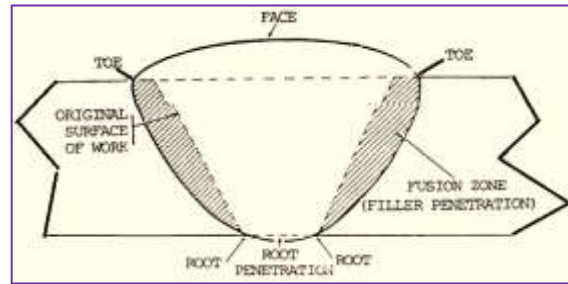

Weldability. The capacity of material to be welded under the imposed fabrication conditions into a specific, suitably designed structure performing satisfactorily in the intended service.

Welder. One who performs manual or semiautomatic welding.

Welder certification. Written verification that a welder has produced welds meeting a prescribed standard of welder performance. Welder performance qualification. The demonstration of a welder's or welding operator's ability to produce welds meeting prescribed standards. Welder registration. The act of registering a welder certification or a photostatic copy of the welder certification.

Welding. A joining process producing coalescence of materials by heating them to the welding temperature, with or without the application of pressure or by the application of pressure alone, and with or without the use of filler metal.

Welding arc. A controlled electrical discharge between the electrode and the workpiece formed and sustained by the establishment of gaseous conductive medium, called arc plasma. Welding blowpipe. Term for oxyfuel gas welding torch.

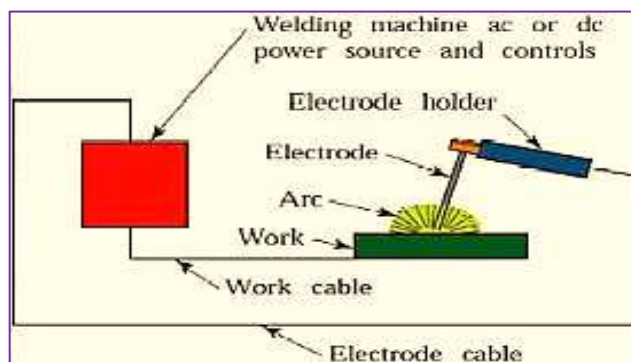

Welding electrode. A component of the welding circuit through which current is conducted and that terminates at the arc, molten conductive slag, or base metal. See arc welding electrode, bare electrode, carbon electrode, composite electrode, covered electrode, electroslog welding electrode, emissive electrode, flux cored electrode, lightly coated electrode, metal cored electrode, metal electrode, resistance welding electrode, stranded electrode, and tungsten electrode.

Welding filler metal. The metal or alloy to be added in making a weld joint that alloys with the base metal to form weld metal in a fusion welded joint.

Welding flux. A granular material comprised of metallic and nonmetallic constituents applied during welding to provide atmospheric shielding and cleaning of the molten weld metal and influence the profile of the solidified weld metal. This material may also provide filler metal and affect the weld metal composition. See active flux, agglomerated flux, alloy flux, bonded flux, fused flux, mechanically mixed flux, neutral flux, reconditioned flux, recycled flux, and virgin flux.

Welding generator. A generator used for supplying current for welding. **Welding ground.** A non-standard and incorrect term for workpiece connection. **Welding head.** The part of a welding machine in which a welding gun or torch is incorporated.

Welding helmet. A device equipped with a filter plate designed to be worn on the head to protect eyes, face, and neck from arc radiation, radiated heat, spatter, or other harmful matter expelled during some welding and cutting processes. **Welding hood.** Term for welding helmet.

Welding leads. The workpiece lead and the electrode lead of an arc welding circuit. Equipment used to perform the welding operation. For example, spot welding machine, arc welding machine, and seam welding machine.

Welding positions. The relationship between the weld pool, joint, joint members, and welding heat source during welding. See also flat welding position, horizontal welding position, overhead welding position, and vertical welding position.

Welding Procedure Qualification Record (WPQR). A record of welding variables used to produce an acceptable test weldment and the results of tests conducted on the weldment to qualify a welding procedure specification. **Welding procedure.** The detailed methods and practices involved in the production of a weldment.

Welding Procedure Specification (WPS). A document providing the required welding variables for a specific application to assure repeatability by properly trained welders and welding operators.

Welding rectifier. A device in a welding power source for converting alternating current to direct current. **welding rod.** A form of welding filler metal, normally packaged in straight lengths that does not conduct the welding current.

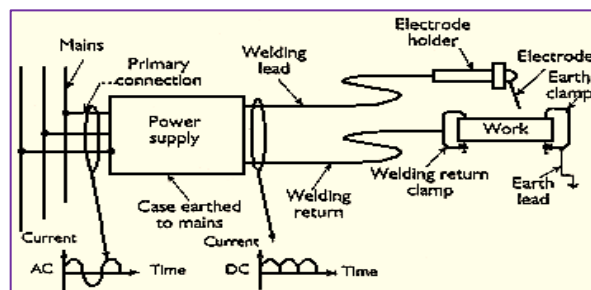

Welding schedule. A written statement, usually in tabular form, specifying values of parameters and the welding sequence for performing a welding operation. Welding sequence. The order of making welds in a weldment.

Welding symbol. A graphical representation of the specifications for producing a welded joint. See application and rules according to AWS A2.4, *Standard Symbols for Welding, Brazing, and Nondestructive Examination*.

Welding tip. A nonstandard term when used for resistance welding electrode for resistance spot welding. The part of an oxyfuel gas welding torch from which gases issue.

Welding wire. A form of welding filler metal, normally packaged as coils or spools that may or may not conduct electrical current depending upon the welding process with which it is used. See also welding electrode and welding rod.

Welding work angle. The angle less than 90° between a line perpendicular to the major workpiece surface and a plane determined by the electrode axis and the weld axis. In a T-joint or a corner joint, the line is perpendicular to the non-butting member. This angle can also be used to partially define the position of guns, torches, rods, and beams. See also drag angle, push angle, and travel angle.

Wetting. The phenomenon whereby a liquid filler metal or flux spreads and adheres in a thin continuous layer on a solid surface (*brazing and soldering*).

Whipping. A welding technique in which the thermal source is oscillated longitudinally as it progresses along the weld path. See also oscillation and weaving.

Wiped joint. A joint made with solder having a wide melting range and with the heat supplied by the molten solder poured onto the joint. The solder is manipulated with a handheld cloth or paddle so as to obtain the required size and contour.

Wire feed speed. The wire rate that is consumed in arc cutting, thermal spraying, or welding. Wire straightener. A device used for controlling the cast and helix of coiled wire to enable it to be easily fed through the wire feed system.

Wire Flame Spraying (FLSP-W). Thermal spraying in which the surfacing material is in wire form.

Workpiece. An assembly, component, member, or part in the process of being manufactured. Workpiece connection. A nonstandard term when used for workpiece connector. Workpiece connector. A device used to provide an electrical connection between the workpiece and the workpiece lead.

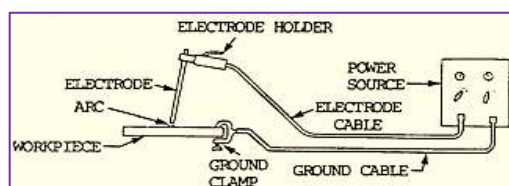

Alphabetical Cross-Reference by Process:

adhesive bonding	AB	infrared soldering	IRS
air acetylene welding	AAW	iron soldering.....	INS
air carbon arc cutting	CAC-A	laser beam air cutting	LBC-A
arc braze welding.....	ABW	laser beam braze welding	LBBW
arc cutting	AC	laser beam brazing.....	LBB
arc spraying	ASP	laser beam cutting.....	LBC
arc stud welding.....	SW	laser beam evaporative cutting	LBC-EV
arc welding	AW	laser beam inert gas cutting.....	LBC-IG
atomic hydrogen welding	AHW	laser beam oxygen cutting.....	LBC-O
bare metal arc welding.....	BMAW	laser beam welding.....	LBW
block brazing	BB	magnetically impelled arc welding.....	MIAW
brazing.....	BW	mash seam welding.....	RSEW-MS
brazing	B	medium vacuum electron beam welding.....	EBW-MV
carbon arc braze welding.....	CABW	metal powder cutting	OC-P
carbon arc brazing	CAB	non-vacuum electron beam welding.....	EBW-NV
carbon arc cutting	CAC	oxyacetylene cutting.....	OFC-A
carbon arc gouging	CAG	oxyacetylene welding.....	OAW
carbon arc welding	CAW	oxyfuel gas cutting	OFC
co-extrusion welding.....	CEW	oxyfuel gas welding.....	OFW
cold welding	CW	oxygen arc cutting.....	OAC
consumable guide electroslag welding	ESW-CG	oxygen cutting	OC
diffusion brazing.....	DFB	oxygen gouging	OG
diffusion welding.....	DFW	oxygen lance cutting.....	OLC
dip brazing	DB	oxyhydrogen gas cutting.....	OFC-H
dip soldering	DS	oxyhydrogen welding.....	OHW
direct drive friction welding	FRW-DD	oxynatural gas cutting.....	OFC-N
electrogas welding	EGW	oxypropane cutting.....	OFC-P
electron beam braze welding	EBBW	percussion welding.....	PEW
electron beam brazing.....	EBB	plasma arc cutting.....	PAC
electron beam cutting	EBC	plasma arc gouging.....	PAG
electron beam welding.....	EBW	plasma arc welding.....	PAW
electroslag welding.....	ESW	plasma spraying.....	PSP
exothermic braze welding.....	EXBW	pressure gas welding.....	PGW
exothermic brazing	EXB	pressure-controlled resistance welding.....	RW-PC
explosion welding.....	EXW	projection welding.....	PW
flame spraying	FLSP	pulsed gas metal arc welding.....	GMAW-P
flash welding	FW	pulsed gas tungsten arc welding.....	GTAW-P
flow brazing.....	FLB	resistance brazing.....	RB
flow welding	FLOW	resistance seam welding.....	RSEW
flux cored arc welding	FCAW	resistance soldering.....	RS
flux cutting.....	OC-F	resistance spot welding.....	RSW
forge welding.....	FOW	resistance welding.....	RW
friction stir welding	FSW	roll welding.....	ROW
friction welding	FRW	self-shielded flux cored arc welding.....	FCAW-S
furnace brazing.....	FB	series submerged arc welding.....	SAW-S
furnace soldering	FS	shielded carbon arc welding.....	CAW-S
gas carbon arc welding	CAW-G	shielded metal arc cutting.....	SMAC
gas metal arc cutting.....	GMAC	shielded metal arc welding.....	SMAW
gas metal arc welding.....	GMAW	short circuit gas metal arc welding.....	GMAW-S
gas shielded flux cored arc welding.....	FCAW-G	soldering.....	S
gas tungsten arc cutting	GTAC	solid-state welding.....	SSW
gas tungsten arc welding	GTAW	submerged arc welding.....	SAW
high energy beam cutting	HEBC	thermal cutting.....	TC
high energy beam welding.....	HEBW	thermal gouging.....	TG
high vacuum electron beam welding.....	EBW-HV		

high velocity oxyfuel spraying	HVOF	thermal spraying.....	THSP
high-frequency seam welding.....	RSEW-HF	thermite welding.....	TW
high-frequency upset welding.....	UW-HF	torch brazing.....	TB
hot isostatic pressure welding.....	HIPW	torch soldering.....	TS
hot pressure welding.....	HPW	twin carbon arc brazing.....	TCAB
induction brazing.....	IB	twin carbon arc welding.....	CAW-T
induction seam welding.....	RSEW-I	ultrasonic soldering.....	USS
induction soldering.....	IS	ultrasonic welding.....	USW
induction upset welding.....	UW-I	upset welding.....	UW
induction welding	IW	vacuum plasma spraying.....	VPSP
inertia friction welding	FRW-I	wave soldering.....	WS
infrared brazing	IRB	wire flame spraying.....	FLSP-W

Welding Classification Chart

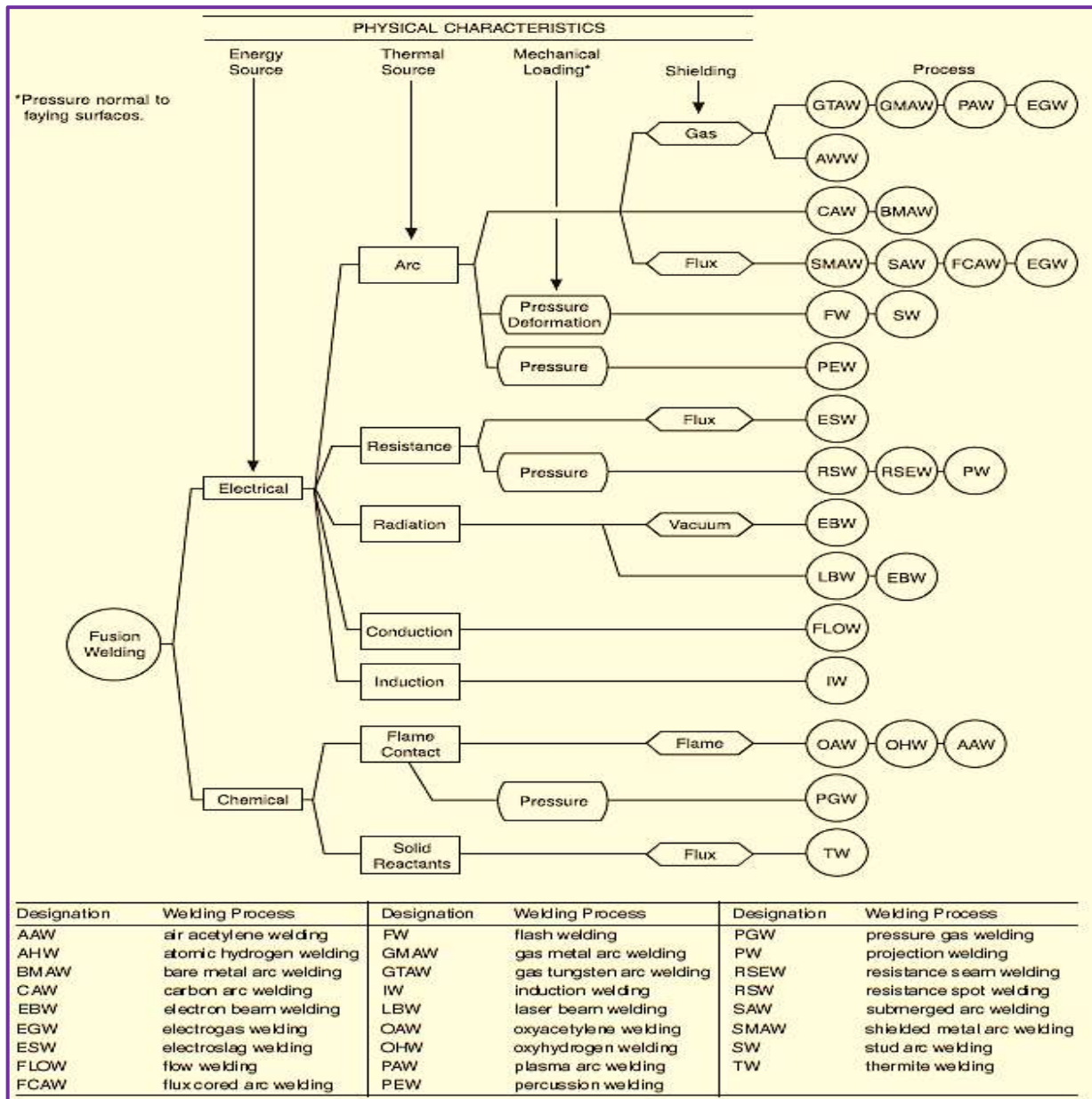

V. WELDING TECHNOLOGY – QUIZ QUESTIONS

Module 1 – Qualification, Inspection and Certification:

1. What AWS documents describe the rules for CWI certification program?
 - a. AWS 5.5;
 - b. AWS D1.1;
 - c. AWS QC – 1;
 - d. AWS 5.1.

2. Welder qualification tests are designed to:
 - a. Test the correctness of the welding procedure;
 - b. Test the welder's skill;
 - c. Prove the weldability of the base material;
 - d. All the above.

3. What AWS document contains the CWI application form?
 - a. AWS D1.1;
 - b. AWS QC-G;
 - c. AWS 5.1;
 - d. AWS Welding Handbook, Volume 1.

4. What is generally considered to be the most important quality of a welding inspector?
 - a. Hold certified welder certificate;
 - b. An engineering degree;
 - c. An associate degree;
 - d. Professional attitude.

5. The vision requirements for a CWI are:
 - a. 20/20 vision;
 - b. 20/40 vision;
 - c. 20/40 natural or corrected vision;
 - e. 230/60 vision.

6. The acronym "KASH" stands for:
 - a. Knowledge, attitude, skills and habits;
 - b. Knowledge, application, skill and habits;
 - c. Knowledge, attitude, skills and honesty;
 - d. Knowledge, application, skills and honesty.

7. The welding inspector should have a basic understanding of:

- a. Welding processes;
- b. Nondestructive testing methods;
- c. Codes and standards;
- d. All of the above.

8. The term used to describe a delay in the production schedule to permit inspection is:

- a. NDE;
- b. Hold point;
- c. Reference point;
- d. Arc strike.

9. The welding inspector must often communicate with:

- a. Welders;
- b. Supervisors;
- c. Welding engineers;
- d. All of the above.

10. NDE personnel (other than visual) should be certified to what document?

- a. QC – 1;
- b. D1.1;
- c. API 1104;
- d. ASNT – TC – 1A.

11. Choose the 4 best duties the Welding Inspector must follow, in the general headings below:

- a. 1. Interpretation of the Plans and Specifications; 2. Verification of Welder Records and Welding Procedures; 3. Production Welding Checks; 4. Keeping Records and Reporting;
- b. 1. Verification of Welder and Procedures; 2. Give an R Stamp for the Manufacturer; 3. Production Welding Checks; 4. Keeping Records and Reporting;
- c. 1. Interpretation of the Plans and Specifications; 2. Change the Manufacturer's Material Test Report (MTR); Choose the Qualified Welder for the Job; Check the Procedure Inspection Tests (PIT);
- d. All the above.

12. The CWI exam has several parts; these are:

- a. Fundamentals, practical, code
- b. Fundamentals, basic, code
- c. Basic, vision test, fundamental
- d. Code, vision test, practical

13. When ferritic steel plates contain cracks in the prepared edges. What NDT method would you use to check this?

- a. Radiography;
- b. Magnetic particle inspection;
- c. Penetrant inspection;
- d. Ultrasonic flaw detection.

14. The title of the AWS Standard, "A3.0" is:

- a. Filler Metal Specifications;
- b. Standard Welding Terms and Definitions;
- c. Guide to CWI Certification;
- d. Requirements for CWI certification.

15. Prior to starting a job assignment, the welding inspector should determine:

- a. What code, standard, or specification applies;
- b. What inspections should be conducted;
- c. When inspections should be conducted;
- d. All of the above.

16. A welder qualification test is to verify:

- a. The skill of the welder;
- b. The quality of the materials;
- c. The non-destructive test procedures;
- d. The manufacturing methods.

17. The BS499 also defines the symbols and types of joint preparations to be used. Which of the following symbols indicates the depth of weld penetration required on the joint?

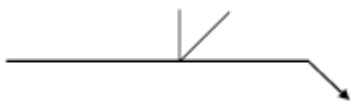
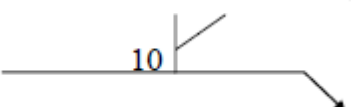
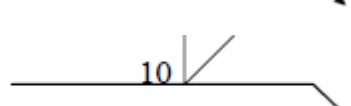
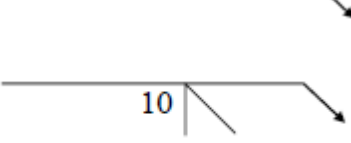
- a. 
- b. 
- c. 
- d. 

18. Which of the following symbols would indicate that a weld has to be finished on the 'other' side of the weld?

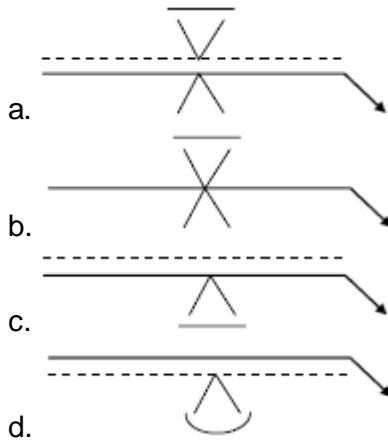

19. A code of practice for visual inspection should include the following:

- a. Before, during and after welding activities;
- b. Before welding activities only;
- c. After welding activities only;
- d. None of the above.

20. You are responsible for controlling welding on site. A large incidence of porosity has been reported in recent welding. Would you investigate?

- a. The electrode type;
- b. The power source;
- c. The electrode storage;
- d. The welding process.

21. Penetrant inspection and magnetic particle inspection are mainly used:

- a. To aid visual inspection;
- b. Because the application says so;
- c. To confirm visual uncertainties;
- d. All the above.

22. In UK practice, BS499 specifies that the drawing dimension quoted for a fillet weld is the:

- a. Leg length;
- b. Throat thickness;
- c. Weld width;
- d. Actual throat thickness.

23. Under normal contract conditions weld procedure approval tests for pipework are:

- a. Mandatory;
- b. Dependant on site and weather conditions;
- c. Dependant upon the contractor's confidence in his procedures;
- d. Only required when MMA welding is used.

24. A magnifying glass may be used during visual inspection, but BS 5289 states that its magnification should be:

- a. Up to 5 \emptyset ;
- b. 2 to 2.5 \emptyset ;
- c. 5 to 10 \emptyset ;
- d. None of the above.

25. When visually inspecting a fillet weld it would normally be sized by:

- a. The leg lengths;
- b. The actual throat thickness;
- c. The design throat thickness;
- d. Both a and c.

26. A code of practice is:

- a. A standard for workmanship only;
- b. A set of rules for manufacturing a specific product;
- c. Levels of acceptability of a weldment;
- d. None of the above.

27. A planar defect is:

- a. Incomplete fusion defects;
- b. Slag inclusion;
- c. Incomplete penetration;
- d. Both a and c.

28. Personnel doing nondestructive testing must be qualified according to:

- a. ASME Section VIII – Boiler and Pressure Code;
- b. ASNT – according to SNT-TC-1A;
- c. ASME Section IX – Welding and Brazing Qualifications;
- d. AWS – Certified Welding Inspector.

29. According to ASME B31.3 the Hydrostatic Test Pressure Gauge shall be:

- a. Equal at least one 1.5 times the Maximum Allowable Working Pressure (MAWP) and shall not exceed 90% of the yield stress of the material at the test temperature;

- b. Equal at least one 1.5 times the Maximum Allowable Working Pressure (MAWP) and shall not exceed 85% of the yield stress of the material at the test temperature;
- c. Equal at least one 1.10 times the Maximum Allowable Working Pressure (MAWP) and shall not exceed 90% of the yield stress of the material at the test temperature;
- d. Equal at least one 1.35 times the Maximum Allowable Working Pressure (MAWP) and shall not exceed 90% of the yield stress of the material at the test temperature.

30. According to ASME B16.34, the CWP liquid test, duration and maximum allowable leakage for 8 in. 300# Globe Valve ASTM A105, are:

- a. 720 psig, during 120s, maximum allowable leakage 20 drops/min;
- b. 740 psig, during 120s, maximum allowable leakage 20 drops/min;
- c. 600 psig, during 120s, maximum allowable leakage 20 drops/min;
- d. 740 psig, during 120s, maximum allowable leakage 40 drops/min.

31. According to ASME B31.3 the Pneumatic Test Pressure Gauge shall be:

- a. Equal at least one 1.10 times the Maximum Allowable Working Pressure (MAWP). Initial test 50% MAWP and will then be increased at steps of approximately 1/5 the test pressure;
- b. Equal at least one 1.25 times the Maximum Allowable Working Pressure (MAWP). Initial test 50% MAWP and will then be increased at steps of approximately 1/20 the test pressure;
- c. Equal at least one 1.15 times the Maximum Allowable Working Pressure (MAWP). Initial test 50% MAWP and will then be increased at steps of approximately 1/10 the test pressure;
- d. Equal at least one 1.25 times the Maximum Allowable Working Pressure (MAWP). Initial test 50% MAWP and will then be increased at steps of approximately 1/10 the test pressure.

32. According to AWS B5.1 the Welding Inspector (WI) shall be:

- a. High school graduate or approved high school equivalency diploma with a minimum of 5 years experience in a function with a direct relationship to welded assemblies;
- b. High school graduate or approved high school equivalency diploma with a minimum of 15 years experience in a function with a direct relationship to welded assemblies;
- c. High school graduate or approved high school equivalency diploma with a minimum of 2 years experience in a function with a direct relationship to welded assemblies;
- d. College graduate or approved college equivalency diploma with a minimum of 5 years experience in a function with a direct relationship to welded assemblies.

33. The certified Welding Inspector should have the skills required to:

- a. Review and correct additional requirements of API570;
- b. Review the Procedure Qualification Record (PQR) and a Welding Procedure Specification (WPS);
- c. Supervise the welder and define the welding process;
- d. Choose the correct electrodes.

34. The specific terms WPS and WQTR mean:

- a. A WPS (Welding Procedure Specification) shows the welder has the understanding and ability of a specific welding condition to ensure that the procedure will produce a good weld. The WQTR (Welder Qualification Test Record) is developed for each welding type and is supported by a PQR (Procedure Qualification Record);
- b. A WPS (Welding Procedure Specification) is developed for each welding type, supported by a PQR (Procedure Qualification Record) to ensure producing a good weld. The WQTR (Welder Qualification Test Record) is a record that shows the welder has the understanding and ability of a specific welding condition;
- c. A WPS (Welding Procedure Specification) is developed for each welding type, supported by a Procedure Qualification Record (PQR) to ensure producing a good weld. The WQTR (Welder Qualification Test Record) is a test of a weld performed more rigorously to ensure producing a good weld;
- d. None of the above.

35. When inspecting a welding, an effective inspector will?

- a. Promptly correct the welder who is producing poor welds;
- b. Keep a short distance from the welding foreman;
- c. Ensure cooperation by incurring obligation through his decisions;
- d. Can be readily swayed by the persuasive arguments from welders.

36. The NAS 410, Certification & Qualification Of Nondestructive Test Personnel is:

- a. The document used by ASNT with over 12,000 memberships in many countries;
- b. The main personnel certification according to SNT-TC-1A;
- c. The main document used in the aerospace industry for certification in NDT;
- d. The ASME document used in design, inspection and repair of pressure vessels.

37. The certified Welding Inspector should have the skills required to:

- a. Review and correct additional requirements of API570;
- b. Write the Procedure Qualification Record (PQR) and the Welding Procedure Specification (WPS);
- c. Supervise the welders and verify the PQR, WPS and the welding processes;
- d. Choose the correct welding equipment and all electrodes to be used.

38. The 6 main steps for a welding coupon test are:

- a. 1. The Root Pass; 2. The Weave Technique; 3. The Cap Weld; 4. Bend Test; 5. Backing Bar Removal; 6. Test Coupons Stamps;
- b. 1. The Root Pass; 2. The Hot Pass; 3. The Cap Weld; 4. Bend Test; 5. Backing Bar Removal; 6. Test Coupons Stamps;
- c. 1. The Root Pass; 2. The Hot Pass; 3. The Cap Weld; 4. The Compress Test; 5. Backing Bar Removal; 6. Test Coupons Stamps;
- d. All the above.

39. The best definition for air-soap solution test leakage in a vessel is:

- a. The vessel is subjected to an internal gas pressure not exceeding the design pressure. A soap or equivalent solution is applied so that connections and welded joints can be examined for leaks;
- b. The interior of the vessel is pressurized with gas, but the design pressure must not be exceeded and the number of gas bubbles indicates the size of leaks;
- c. The vessel is attached to a vacuum pump evacuating to a pressure of 0.5 psi absolute and all connections to the vacuum pump are sealed off and the internal pressure of the part is measured;
- d. The vessel is pressurized with a mixture of 50% Freon and carbon dioxide or 50% Freon and nitrogen and each joint is carefully probed to detect leaks.

40. Give the 10 main safety precautions a conscious Welding Inspector must check before his welding inspection activities:

- a. 1. Electrical Shock; 2. Torch Valves; 3. Fumes and Gases; 4. Fire or Explosion; 5. Flying Sparks; 6. Safety with Gas Cylinders; 7. Supervise Welders; 8. Flashback; 9. Eye Protection; 10. Hot Work Procedures;
- b. 1. Electrical Shock; 2. Arc Rays; 3. Fumes and Gases; 4. Fire or Explosion; 5. Flying Sparks; 6. Safety with Gas Cylinders; 7. Chemical Exposure; 8. Flashback; 9. Eye Protection; 10. Hot Work Procedures;
- c. 1. Electrical Shock; 2. Arc Rays; 3. Fumes and Gases; 4. Fire or Explosion; 5. Flying Sparks; 6. Chaining of Gas Cylinders; 7. Work Permits; 8. Chemical Exposure; 9. Flashback; 10. Eye Protection;
- d. 1. Electrical Shock; 2. Arc Rays; 3. Fumes and Gases; 4. Goggles Eye Protection; 5. Flying Sparks; 6. Safety with Gas Cylinders; 7. Welding Meetings; 8. Flashback; 9. Eye Protection; 10. Hot Work Procedures;

ANSWERS – MODULE 1

1. c	11. a	21. d	31. d
2. b	12. a	22. d	32. a
3. b	13. b	23. a	33. b
4. d	14. b	24. b	34. b
5. c	15. d	25. d	35. a
6. a	16. a	26. b	36. c
7. d	17. b	27. d	37. c
8. b	18. a	28. b	38. b
9. d	19. a	29. a	39. a
10. b	20. d	30. b	40. b

Module 2 – Safety in Welding:

1. The welding inspector is expected to which of the following safety hazards:
- a. Radiation;
 - c. Electrical shocks;
 - d. Eye hazards;
 - d) All of the above.

2. A document, which covers safety in welding and cutting, is:
 - a. AWS D1.1;
 - b. API 1104;
 - c. ANSI/ASC Z49.1;
 - d. ASME Section VIII.

3. Safety training is mandated under provisions of:
 - a. AWS "Safe Practice";
 - b. OSHA;
 - c. ASME Code;
 - d. Welding Handbook, Volume 2.

4. The abbreviation 'MSDS' means:
 - a. Management Support and Daily Safety;
 - b. Materials Strength and Discontinuity Sheet;
 - c. Materials Safety Data Sheet;
 - d. Material Strength and Data Sheet.

5. A 'Hot Work Permit' is required for:
 - a. All welding operations;
 - b. All cutting operations;
 - c. All preheating operations;
 - d. Areas where a fire hazard may occur during welding, cutting, or preheating operation.

6. Protective equipment not suitable for eye protection from welding radiation includes:
 - a. Welding helmet with filter plates;
 - b. Clear safety goggles;
 - c. Safety goggles with filter plates;
 - d. Protective screens.

7. Suitable clothing materials for welding and cutting are:
 - a. 65% cotton, 35% polyester;
 - b. Wool;
 - c. Chemically treated cotton;
 - d. Answers b and c.

8. In avoiding fumes during welding, the most important factor is:
 - a. The type of base metal;

- b. The position of the welder's hand;
 - c. The type of welding process;
 - d. The position of the welding machine.
9. Acetylene becomes unstable above what pressure?
- a. 5 psi;
 - b. 10 psi;
 - c. 15 psi;
 - d. None of the above.
10. Electrical currents above approximately 6 mA are considered:
- a. Primary currents;
 - b. Harmful;
 - c. Secondary currents;
 - d. Answers b and c above.

ANSWERS – MODULE 2

1. d	6. b
2. c	7. d
3. b	8. b
4. c	9. c
5. d	10. d

Module 3 – Welding Processes, Cutting and Inspection Knowledge:

1. Which of the following is the function of the flux coating of a SMAW electrode?
- a. Alloying;
 - b. Deoxidation;
 - c. Shielding;
 - d. All the above.
2. In the AWS system SMAW electrode designations, the next to the last digit refers to:
- a. Impact strength;
 - b. Electrode coating;
 - c. Welding position;
 - d. Strength.
3. Which of the following is an incorrect statement about a SMAW electrode as E7024?
- a. It is a low hydrogen type;

- b. The weld deposit has a minimum tensile strength of 70,000 psi;
 - c. It is suitable for use in the flat and horizontal fillet positions only;
 - d. It is an electrode for welding carbon steel.
4. Which of the following is not considered a type of a metal transfer for GMAW?
- a. Short circuiting;
 - b. Spray;
 - c. Globular;
 - d. Droplet.
5. Which of the following gases can be used as shielded gases for GMAW?
- a. Carbon dioxide;
 - b. Argon-oxygen;
 - c. Argon-carbon dioxide;
 - d) All the above.
6. For FCAW, the second digit (1) in an electrode marked (E71T-5) refers to:
- a. Strength;
 - b. Welding position;
 - c. Chemical composition;
 - d. Usability.
7. The metal transfer considered the least desirable of the three major GMAW variations is:
- a. Short-Circuiting;
 - b. Spray Arc;
 - c. Globular;
 - d. Double-U-groove.
8. Using GMAW, the more recommended metal transfer for welding stainless steel is:
- a. Spray-arc;
 - b. Vertical welding;
 - c. Short-circuiting;
 - d. Globular.
9. The carbon steel electrodes of choice generally used in GMAW are:
- a. ER308L and ER309L;
 - b. ER70S-3 and ER70S-6;
 - c. ER70S-2, ER70S-4;
 - d. Answers a and b are correct.
10. Using GMAW and short-circuit transfer mode, the most common shielding gas for carbon steel electrodes is:

- a. 15%-Ar and 25% CO₂;
- b. 75%-Ar and 15% CO₂;
- c. 75%-Ar and 25% CO₂;
- d. 15%-Ar and 85% CO₂.

11. In GMAW, the more useful welding transfer technique for joining thin materials in any position is:

- a. Short-arc welding;
- b. 1G welding position;
- c. Spray-arc welding;
- d. Flat welding position.

12. The shielding gas, recommended position, and electrode size, when welding aluminum using the spray-arc process at minimum 95A, could be:

- a. Argon, horizontal position, 0.045 in.;
- b. Helium, flat position, 0.035 in.;
- c. Argon, flat position, 0.030 in.;
- d. None of the above.

13. Flux-cored electrode is:

- a. A continuous, GMAW tubular electrode wire specifically designed to weld mild steels using only the process FCAW;
- b. A continuous, GMAW tubular electrode wire specifically designed to weld mild steels using either CO₂ gas or Argon-CO₂;
- c. A continuous, GMAW tubular electrode wire specifically designed to weld special alloy steels using either CO₂ gas or Argon-CO₂;
- d. A continuous, FCAW tubular electrode wire specifically designed to relieve stresses in first weld.

14. What could be the shielding gas flow requirements for small weld pools using short-circuiting and pulsed-spray and globular transfer?

- a. For short-circuiting and pulsed-spray about 15 l/min (0.53 ft³/min) is generally suitable, whereas for globular transfer around 10 l/min (0.35 ft³/min) is preferred.
- b. For short-circuiting and pulsed-spray about 10 l/min (0.35 ft³/min) is generally suitable, whereas for globular transfer around 15 l/min (0.53 ft³/min) is preferred.
- c. For globular transfer about 10 l/min (0.35 ft³/min) is generally suitable, whereas for short-circuiting and pulsed-spray around 15 l/min (0.53 ft³/min) is preferred.
- d. None of the above.

15. Using GMAW, how argon can be used for welding ferrous materials?

- a. Argon and most oxygen (O₂) shielding gases is commonly used for welding ferrous materials, however, aluminum oxide will form;

- b. Argon is combined with elements for oxides which are released from the weld puddle in the form of slag and scale, for welding ferrous materials;
- c. Argon is an active gas, used for welding ferrous materials, but produces an oxidizing effect, that can be consistently free of porosity and defects;
- d. Argon is an inert gas always mixed with other gases such as oxygen, helium, hydrogen, carbon dioxide and/or nitrogen, for welding ferrous materials.

16. Which of the following is not an essential element of an FCAW system?

- a. Constant voltage power supply;
- d. External shielding gas;
- c. Tubular electrode;
- d. Wire feeder.

17. When welding aluminum with the GTAW process, what type of welding current is most commonly used?

- a. DCEP;
- b. DCEN;
- c. AC;
- d. Answers a and b above.

18. The welding processes SAW and ESW are similar in that:

- a. Both are an arc welding process;
- b. Both use shielding gases;
- c. Both use a granular flux, which becomes molten;
- d. All the above.

19. What welding process produces welds in a single pass, with the progression vertically upward along the joint?

- a. SAW;
- b. ESW;
- c. FCAW;
- d. Answers a and b above.

20. Which welding process is considered to be a chemical welding process?

- a. OAW
- b. SW
- c. ESW
- d. GTAW

21. Which of the following cutting processes can cut any metal; and consecutively the width of cutting is referred to as:

- a. PAW, OFC; Gap
- b. CAC-A, PAC; Kerf
- c. ESW, OAW; Dross
- d. PAC, OFC; Drag

22. Pure carbon dioxide (CO₂) is:

- a. An inert gas which is used both pure and in combination with other gases to achieve desired arc characteristics for welding of both ferrous and non-ferrous metals;
- b. An inert gas, but is an active gas, widely used for the welding of non-ferrous metals producing an oxidizing effect;
- c. An active gas which is used both pure and in combination with other gases to achieve desired arc characteristics for welding only non-ferrous materials;
- d. An active gas, not an inert gas, widely used for the welding of ferrous materials, producing an oxidizing effect.

23. What forms The Binary Shielding Gas mixtures and what is the application?

- a. Argon-Oxygen: Small amounts of O₂ to Ar greatly stabilizes the weld arc, increasing the filler metal droplet rate, lowers the spray arc transition current, and improves wetting and bead shape;
- b. Argon-Oxygen: Large amounts of O₂ to Ar greatly stabilizes the weld arc, increasing the filler metal droplet rate, lowers the spray arc transition current, and improves wetting and bead shape;
- c. Argon-Oxygen: Small amounts of O₂ to Ar destabilizes the weld arc, increasing the filler metal droplet rate, lowers the spray arc transition current, and improves wetting and bead shape.
- d. Argon-Oxygen: Small amounts of O₂ to Ar stabilizes the weld arc, decreasing the filler metal droplet rate, increases the spray arc transition current, and improves wetting and bead shape.

24. Choosing a flux-cored wire containing 2.0-3.0% nickel, minimum 70 ksi UTS after stress relief, useful for pressure vessels fabrication, with chemical requirements for welding ASTM A-242 and A-588 weathering steels, could be:

- a. E70T-1/T-9 – Downhand;
- b. E81T1-Ni2 – High Toughness-All Positions;
- c. E70T-2 – Single Pass;
- d. E81S1-Ni2 – High Toughness-All Positions.

25. Using a Mig Calculator find the results for the following data:

- 1. Material: Aluminum,
- 2. Thickness: 1/4 in. (6.4 mm),
- 3. Spray Arc Transfer.

a. Wire Size & Wire Feed Speed: 0.035" (0.9 mm) at 400-425 ipm; Shielding Gas: Helium + Argon + CO₂; Voltage Range: 20-21 Volts; Amperage Range: 160-170;

- b. Wire Size & Wire Feed Speed: 0.035" (0.9 mm) at 450-475 ipm; Shielding Gas: 98% Argon + 2% O₂: Voltage Range: 24-25 Volts; Amperage Range: 180-190;
- c. Wire Size & Wire Feed Speed: 0.045" (0.9 mm) at 400-425 ipm; Shielding Gas: Helium + Argon + CO₂: Voltage Range: 20-21 Volts; Amperage Range: 160-170;
- d. Wire Size & Wire Feed Speed: 3/64" (1.2 mm) at 350-375 ipm; Shielding Gas & Voltage Range: Argon: 24-25 Volts; Amperage Range: 180-210.

26. In MAG/CO₂ welding which parameter gives the greatest control of weld appearance during dip transfer or short-circuiting welding?

- a. Wire stick-out length;
- b. Amperage;
- c. Wire feed speed;
- d. Inductance.

27. In submerged arc welding (SAW) the use of excessively high voltage would result in:

- a. Insufficient flux melting;
- b. Excessive flux melting;
- c. Slag removal difficulties;
- d. Spatter.

28. Cellulosic electrodes are often used when welding the root pass of pipes in the field because:

- a. Hydrogen control is needed;
- b. There are iron powders in the electrode;
- c. Higher arc voltage can be obtained;
- d. Shorter arc length can be obtained.

29. In the welding of austenitic stainless steels, the electrode and plate material can be purchased with low carbon contents. The reason for this is to prevent:

- a. Cracking in the heat affected zone;
- b. The formation of chromium carbides;
- c. Cracking in the weld metal;
- d. Distortion.

30. Submerged arc fluxes can be supplied in two forms. These are:

- a. Sintered and agitated;
- b. Agitated and fused;
- c. Sintered and agglomerated;
- d. Fused and agglomerated.

31. Welding a steel plate with a CE of 0.45 would require preheating to:

- a. Prevent the formation of sulphides;
- b. Prevent hardening in the HAZ;
- c. Prevent the formation of carbides;
- d. To improve mechanical properties in the weld.

32. Which of the following processes uses the “keyholing” system of fusion?

- a. Friction welding;
- b. Diffusion bonding;
- c. Electron beam welding;
- d. Autogenous TIG weldings.

33. The incomplete root penetration in a butt joint weld could be caused by:

- a. Excessive root face width;
- b. Excessive root gap size;
- c. Low current setting;
- d. Both A and C.

34. The incomplete root fusion in a weld would certainly be caused by:

- a. Linear misalignment;
- b. Incorrect tilt angle;
- c. Differing root face widths;
- d. All the above.

35. Undercut is principally caused by:

- a. Excessive amps;
- b. Excessive volts;
- c. Excessive travel speed;
- d. All the above.

36. MMA electrodes can be grouped into three main types. These are:

- a. Basic, cellulosic and rutile;
- b. Neutral, cellulosic and rutile;
- c. Basic, cellulosic and neutral;
- d. None of the above.

37. The main cause of porosity in welded joints is:

- a. Poor access;
- b. Loss of gas shield;

- c. Rusty materials;
- d. All the above.

38. A weave technique may give rise to:

- a. Better profiles;
- b. Improved toe blending;
- c. Improved ripple shape;
- d. All the above.

39. Movement of the arc in MMA welding by magnetic forces is called:

- a. Arc deviation;
- b. Arc misalignment;
- c. Arc blow;
- d. Arc eye.

40. Which electrode classification would be relevant according to AWS A5.1, F-No. 2?

- a. E 6013;
- b. E 5133;
- c. E 7018 – G;
- d. Fleetweld 5.

41. The main types of welding joints are:

- a. Flat, square, angled, upright and vertical;
- b. Horizontal, single-V, double-V, T-joint and overhead;
- c. Butt, lap, corner, T-joint and edge joint;
- d. Butt, single bevel, double bevel, plasma and edge joint.

42. Which joint preparation would be more appropriate for joining metal plates 1 in. thick?

- a. Single-V-groove;
- b. Single-Bevel-groove;
- c. Double-V-groove;
- d. Double-U-groove.

43. Which welding position uses a downhand welding and produces good-quality welds more safely and most economically?

- a. The flat position.
- b. The upright position;
- c. The overhead position;
- d. The vertical position;

44. The most common way to make a V-groove in stainless steel is by:

- a. Oxyacetylene cutting;
- b. Carbon arc cutting;
- c. Plasma arc cutting;
- d. Pneumatic cutting.

45. What can be the total angle of a single-V-groove weld made with a backing strip in a 3/4 in. steel plate to be welded in the vertical position with a root opening of 1/4 in.?

- a. 30°;
- b. 45°;
- c. 35°;
- d. 50°.

46. What does a letter or number in the tail end of a welding symbol's reference line indicate?

- a. The size of the groove angle or, for plug welds, the size of the included angle of countersink;
- b. The size of the root opening or, for plug and slot welds, the depth of filling;
- c. A specification, process, or other reference data;
- d. The pitch of the weld.

47. In the 1G position for welding pipes, the pipe must be:

- a. Rotated;
- b. Angled;
- c. Horizontal;
- d. Vertical.

48. The main positions for welding pipes are:

- a. 1G, 2G, 3G, 4G;
- b. 1G, 2F, 3F, 5G;
- c. 1F, 2F, 5G, 6G;
- d. 1G, 2G, 5G, 6G.

49. Which of the following commonly used industry standard addresses the hardness properties of components intended for use in sour service?

- a. AWS D1.1;
- b. ASME Section IX;
- c. NACE MR-01-75;
- d. ANSI B31.1.

50. Is it permissible to do any welding on a pressure vessel that has been PWHT?

- a. Yes;
- b. No.

51. Which of the following describes the “2G” position of the test plates and the axis of the weld for groove welds per AWS D1.1?

- a. Plates horizontal (flat);
- a. Plates vertical, axis of weld horizontal;
- c. Plates vertical, axis of weld vertical;
- d. Plates horizontal, welding from overhead.

52. Why the control of tip-to-work distance is so important?

- a. Is very important, since for solid wires and short arc welding, as the minimum tip-to-work distance recommended is 3/8 in. (10 mm);
- b. Is very important, as the tip-to-work distance increases the arc becomes less stable;
- c. Is very important, as the most common recommended flux-cored wire is 0.045 in. (1.2 mm);
- d. All of the above.

53. To ensure complete penetration in a V-groove weld when prevented from welding on the back side, you should use a:

- a. Small-diameter electrode;
- b. Closer joint fit;
- c. Higher welding current;
- d. Backing strip.

54. In the 3F position for welding plate, the weld must be deposited:

- a. From the flat position;
- b. From underneath the workpieces;
- c. With the plates in a vertical position;
- d. With the axis of the weld in a horizontal position.

55. The circle used in a welding symbol means that welding is to be:

- a. To ensure that subsequent deposits are sound;
- b. To be all around the joint;
- c. To remove any excess flux;
- d. To relieve stresses in the first weld.

56. The small flag in a welding symbol means the weld is to be made in:

- a. Bevel-groove weld;
- b. The field work;

- c. Square-groove weld;
- d. The pipe shop.

57. PAW – Plasma Arc Welding is similar to:

- a. SMAW;
- b. GTAW;
- c. FCAW;
- d. SAW.

58. How is called the thickness of thin sheet metals and how they are measured?

- a. Slitters, measured by thickness caliper rulers from 30 to 8 caliper;
- b. Rolled, measured by thickness micrometers from 30 to 8 micrometer;
- c. Gauge, measured by thickness gauges from 30 to 8 gauge;
- d. All the above.

59. What is the essential single method to prevent the occurrence of cold cracking?

- a. Post Weld Stress relieving;
- b. Solution Treating and aging;
- c. Pre-heating;
- d. None of the above.

60. Which of the following defects is not classified as welding discontinuity?

- a. Cold Shut;
- b. Slag inclusion;
- c. Porosity;
- d. Lack of penetration.

61. Give the meaning designations of an E7018 electrode.

- a. “E” means material elongation; “70” strength of the weld; “1” welding any position; “8” low hydrogen iron powder;
- b. “E” means covered electrode; “70” strength of the weld; “1” downhand position; “8” low hydrogen iron powder;
- c. “E” means covered electrode; “70” strength of the weld; “1” welding in any position; “8” low hydrogen iron powder;
- d. None of the above.

62. According to ASME B31.1, PWHT of a P4 material is not mandatory when...

- a. The nominal material thickness is 13 mm (1/2 inch) or less;
- b. The maximum specified carbon content of the material to be welded is 0.15%;

- c. The applied preheating temperature is 120°C (250 °F);
- d. All of the above.

63. If threaded joints are sealed welded, what percentage of the threads the weld must cover, as per ASME B31.3?

- a. 25%;
- b. 50%;
- c. 75%;
- d. 100%.

64. The type of weld produced by filling an elongated hole in an overlapping member attaching it to the member beneath is called a?

- a. Slot weld;
- b. Plug weld;
- c. Spot weld;
- d. Seam weld.

65. The type of weld used to build up thinned surfaces provided a layer of corrosion protection. Or provide a layer of abrasion resistant material, is referred to as a?

- a. Surfacing weld;
- b. Edge weld;
- c. Flare weld;
- d. Slot weld.

66. In a completed weld, the junction between the weld face and base metal is called as?

- a. Root;
- b. Weld edge;
- c. Toe;
- d. Leg.

67. The height of the weld face above the base metal in a groove weld is called as?

- a. Crown;
- b. Weld reinforcement;
- c. Buildup;
- d. Face.

68. In a partial penetration single V-groove weld, the dimension measured from the joint root to where the weld penetration stops is?

- a. Joint penetration;

- b. Effective throat;
- c. Root penetration;
- d. Depth of fusion.

69. The graphic description of any type of weld is called as:

- a. Tail;
- b. Reference line;
- c. Weld symbol;
- d. Arrow.

70. A triangular-shaped weld symbol represents what type of weld?

- a. Fillet weld;
- b. Bevel groove;
- c. Flare groove;
- d. V-groove.

71. What constituent is needed in the coating of an electrode to prevent the formation of porosity in the welding of rimming steels?

- a. Iron powders;
- b. Calcium fluoride;
- c. Silicon;
- d. Calcium carbonate.

72. The pipe position test to qualify welders in T, K and Y connections is defined as:

- a. 2G;
- b. 5G;
- c. 6G;
- d. 6GR.

73. The number at the left of the groove weld symbol in a welding symbol refers to the?

- a. Depth of bevel;
- b. The length of weld;
- c. The weld quality standard;
- d. The weld procedure to use.

74. A common gas mixture used in MIG welding nickel alloys, to combine good levels of penetration with good arc stability would be:

- a. 100% CO₂;
- b. 100% argon;

- c. 80% argon and 20% CO₂;
- d. 98% argon and 2% oxygen.

75. Which type of SAW flux is more resistant to moisture absorption?

- a. Fused;
- b. Agglomerated;
- c. Basic;
- d. All the above have the same resistance.

76. The flame temperature of oxy/acetylene mixture gas is given as:

- a. 3200°C;
- b. 2300°C;
- c. 5000°C;
- d. None of the above.

77. Hydrogen cracking in the weld metal is likely when welding:

- a. Carbon manganese steels;
- b. Stainless steels;
- c. Micro alloyed steels (HSLA);
- d. Low carbon steels.

78. The EN 288 standard would refer to which of the following:

- a. Welder approval testing;
- b. Welding equipment;
- c. Welding procedure approval;
- d. Consumables for weldings.

79. Which gas should be used when welding aluminium alloys with tungsten arc gas shielded?

- a. Nitrogen;
- b. Carbon dioxide;
- c. Argon/carbon dioxide mixture;
- d. Argon.

80. Inherent rectification of the electrical output is produced in the arc when TIG welding using:

- a. AC with a suppressor;
- b. AC without a suppressor;
- c. DC with reverse polarity;
- d. DC with straight polarity.

81. Hot shortness is a term used to indicate:

- a. Lamellar tearing;
- b. Solidification cracking;
- c. Hydrogen cracking;
- d. None of the above.

82. In welding procedure terms, a change in essential variable means:

- a. Re-qualification of the weld procedure;
- b. Possible changes in the weld's microstructure;
- c. Possible changes in the mechanical properties;
- d. All the above.

83. Weld symbols placed on a dotted line in accordance with ISO requirements means:

- a. Weld on "arrow" side;
- b. Weld on "other" side;
- c. Weld on site;
- d. Full penetration required.

84. Cold lap is a condition where:

- a. The weld melts within the part;
- b. The weld does not solidify within the root;
- c. The weld filler metal does not properly fuse with the base metal;
- d. Scatters within the film.

85. Porosity is the result of:

- a. Gas entrapment in the solidifying metal;
- b. A inspection that can be performed more rapidly;
- c. A higher image definition;
- d. Lower equipment costs.

86. Shrinkage is:

- a. A form of discontinuity that appears as dark spots on the radiograph;
- b. Produced when metal solidifies between two original streams of melt coming;
- c. A distribution of very fine lines or small elongated cavities;
- d. None of the above.

87. Internal or root undercut is:

- a. Volumetric defects such as porosity;

- b. Tight linear defects such as cracks;
- c. Erosion of the base metal next to the root of the weld;
- d. The flaw type does not matter.

88. Hydrogen controlled electrodes were developed principally for:

- a. The prevention of porosity;
- b. The prevention of cracking;
- c. The enhancement of arc voltage;
- d. Their ease of arc starting.

89. What is the ASME "F-number"?

- a. Is a code that covers the welding of steel structures;
- b. Is the size and configuration of a weldment;
- c. Is the specification of the weld electrode or wire to be used in a specific WPS.
- d. All the above.

90. What is the ASME "P-number"?

- a. Is the specification of the base metal that can be welded with a specific WPS, to reduce the numbers of welding and brazing procedure qualifications;
- b. is the requirement for an alloy material;
- c. a rule to measure the weld quantity and quality;
- d. None of the above.

ANSWERS – MODULE 3

1. d	11.a	21.b	31.b	41.c	51.a	61.c	71.c	81.b
2. c	12.c	22.d	32.c	42.c	52.d	62.a	72.d	82.d
3. a	13.b	23.a	33.d	43.a	53.d	63.b	73.a	83.b
4. d	14.b	24.b	34.d	44.c	54.c	64.a	74.b	84.c
5. d	15.d	25.d	35.d	45.b	55.b	65.a	75.a	85.a
6. b	16.d	26.d	36.a	46.c	56.b	66.c	76.a	86.a
7. c	17.c	27.b	37.d	47.a	57.b	67.b	77.c	87.c
8. c	18.c	28.c	38.d	48.d	58.c	68.c	78.c	88.b
9. b	19.b	29.b	39.c	49.c	59.c	69.c	79.a	89.c
10. c	20.b	30.d	40.a	50.b	60.a	70.a	80.b	90.a

Module 4 - Welding Metallurgy, NDT and Destructive Testing:

1. Rapid quenching of steel from the austenitic range results in a hard, brittle structure known as:
- a. Pearlite;
 - b. Carbide;

- c. Cementite;
- d. Martensite.

2. Very low cooling of steel may result in the production of soft, ductile microstructure which as lamellar appearance when reviewed under high magnification. This structure is referred to as:

- a. Martensite;
- b. Pearlite;
- c. Bainite;
- d. Ferrite.

3. When rapid cooling produces martensite structure, what sub-critical heat treatment may be applied to improve the ductility of the steel?

- a. Quenching;
- b. Tempering;
- c. Annealing;
- d. Normalizing.

4. What heat treatment is characterized by holding the part at the austenitizing temperature for some time and then slow cooling in the furnace?

- a. Normalizing;
- b. Quenching;
- c. Annealing;
- d. Stress relief.

5. What heat treatment is characterized by holding the part in austenitizing temperature, and then cooling it in still air?

- a. Normalizing;
- b. Quenching;
- c. Annealing;
- d. Tempering.

6. Steel heated above the lower transformation temperature (A_1) will change micro-structural alignment. This temperature is?

- a. 1333°F;
- b. 933°F;
- c. 1560°F;
- d. 3600°C.

7. LP inspection is:

- a. A very special nondestructive testing;
- b. Uses magnetic fields and small magnetic particles (i.e. iron filings) to detect flaws in components;
- c. A method used to reveal surface breaking flaws by bleed-out of a colored or fluorescent dye from the flaw based on the ability of a liquid to be drawn by capillary action;
- d. None of the above.

8. "Before the first welding arc is struck, materials should be examined to see if they meet specifications for quality, type, size, cleanliness and freedom from defects. Grease, paint, oil, oxide film or heavy scale should be removed." This description is for:

- a. UT inspection;
- b. RT inspection;
- c. VT inspection;
- d. PT inspection;

9. VT inspection is:

- a. The Zyglo system of where fluorescent dyes were added to the liquid penetrant;
- b. Must take place prior to, during and after welding and materials should be examined to see if they meet specifications for quality, type, size, cleanliness and freedom from defects;
- c. Introduced and found to be more sensitive for ferromagnetic iron and steels;
- d. None of the above.

10. The LPI can be used to test most materials provided the surface of the part is:

- a. Heated to a temperature above 100° F;
- b. Is not extremely rough or porous;
- c. Smooth and uniform;
- d. Cleaned with number 0.05 grit.

11. Which of the following should be removed in order to obtain a good penetrant test?

- a. Varnish;
- b. Oxides;
- c. Plating;
- d. All of the above.

12. Four groups of liquid penetrants are presently in use. The group that represents the water washable dye penetrant is:

- a. Group I;
- b. Group III;
- c. Group IV;
- d. Group II.

13. Which developer form is used for dry powder developer?

- a. Form a;
- b. Form b;
- c. Form c;
- d. Form d.

14. Which of the following is a disadvantage of LPI?

- a. Only surface breaking flaws can be detected;
- b. Surface finish and roughness can affect inspection sensitivity;
- c. Post cleaning is required;
- d. All of the above.

15. The purpose of pre-heating low alloy steel pipes before electric arc welding is to:

- a. Refine grain structure;
- b. Relieve internal stress;
- c. Retard rapid cooling;
- d. Regulate excessive expansion.

16. Wet developers are applied:

- a. After the part has been dried;
- b. Immediately after the excess penetrant has been removed from the parts surface;
- c. After the emulsifier dwell time;
- d. After the part has been dipped in cleaner/remover.

17. When performing a magnetic particle test with a coil, the part should be placed:

- a. Along the outside edge the coil;
- b. Along the inside edge of the coil;
- c. Centered in the coil;
- d. None of the above.

18. A yoke establishes a magnetic field:

- a. That can be constant or pulsed;
- b. Between the north and south poles of the yoke;
- c. Equally in all directions around the poles;
- d. Both a and b.

19. Which of the following has a very weak and negative susceptibility to magnetic field?

- a. Ferromagnetic materials;

- b. Diamagnetic materials;
- c. Paramagnetic materials;
- d. None of the above.

20. When a ferromagnetic material is in a unmagnetized state, the domains are:

- a. Aligned in a north and south direction;
- b. Aligned in an east and west direction;
- c. Randomly organized;
- d. Balanced to produce a gauss rating of 2.

21. An object has a magnetic pole on one end and a magnetic pole on the other end, called as:

- a. Dipole;
- b. Inductor;
- c. Capacitor;
- d. A ferromagnetic material.

22. Materials can be demagnetized by:

- a. Heating above their curie temperature;
- b. Subjecting the component to a reversing and decreasing magnetic field;
- c. Both a and b;
- d. None of the above.

23. A root bend test is used to test the amount of weld:

- a. Ductility;
- b. Elongation;
- c. Hardness;
- d. Penetration.

24. The current carrying conductor induces a magnetic field:

- a. By direct induction;
- b. That is longitudinal;
- c. That is circular;
- d. By magnostriiction.

25. When the magnetizing current is stopped, a ferromagnetic material will:

- a. Remain magnetically saturated;
- b. Become demagnetized;
- c. Retain a residual magnetic field within the component;
- d. None of the above.

26. When testing parts with magnetic particles, it is best to magnetize the part:

- a. In two directions at right angles to each other;
- b. With AC whenever possible;
- c. With DC whenever possible;
- d. With an amperage of at least 1000 amps.

27. In magnetic flaw detectability, a circular magnetic field has lines of force that run:

- a. Parallel to the long axis of the part;
- b. Varies from zero at the center of the component to a maximum at the surface;
- c. Circumferentially around the perimeter of the part;
- d. Opposite the waveform of the magnetic particle machine used.

28. The use of prods is sometimes restricted because:

- a. They produce a relatively weak field;
- b. There is a potential for arcing that could damage parts;
- c. It is not possible to control the field orientation;
- d. None of the above.

29. A calibration block produced by the International Institute of Welding is called:

- a. An IIW block;
- b. A DSC block;
- c. A rompus block;
- d. A shear wave calibration block.

30. Which type of screen displays the amount of received ultrasonic energy as a function of time?

- a. A-scan;
- b. B-scan;
- c. C-scan;
- d. All of the above.

31. A typical UT inspection system consists of:

- a. Reference standards are required for equipment calibration;
- b. Several functional units, such as the pulser/receiver, transducer, and display devices;
- c. Electronic equipment that provides instantaneous results;
- d. None of the above.

32. Inclusions in casting metals are:

- a. Thin linearly disposed discontinuities that occur after the melt has solidified;

- b. Areas of lacy texture with diffuse outlines;
- c. Nonmetallic materials in an otherwise solid metallic matrix;
- d. None of the above.

33. Which of the following could influence the behavior of a transducer?

- a. Electrical construction;
- b. Material construction;
- c. Mechanical construction;
- d. All of the above.

34. The measure of how a signal from a defect compared to other background reflections is called:

- a. Acoustic impedance;
- b. Signal to noise ratio.
- c. Refraction;
- d. Reflection.

35. In UT, DAC stands for:

- a. Distance Application Code;
- b. Direct Amplitude Code;
- c. Distance Amplitude Correction;
- d. Divergence Application Couplant.

36. What is the most common cause of failure in root bend tests?

- a. Too high a current setting;
- b. Too long a pause in the down cycle of the weave;
- c. Lack of fusion and penetration;
- d. Too high a travel speed.

37. In UT, the Snell's Law describes the relationship between the sound velocity and:

- a. The refracted angle of the wave;
- b. The reflected angle of the wave;
- c. Both A and B;
- d. None of the above.

38. Which of the following steels is likely to be more susceptible to hydrogen cracking?

- a. Carbon equivalent of less than 0.25 %;
- b. Carbon equivalent of 0.35%;
- c. Carbon equivalent of 0.38%;
- d. Carbon equivalent of 0.43%.

39. The sound that emanates from a piezoelectric transducer originates:

- a. From a point on the active surface;
- b. From most of the active surface;
- c. From a small area in the center of the active surface;
- d. From the edges of the active surface.

40. A decibel is:

- a. A unit of measure used only for sound measurements;
- b. A logarithmic unit that describes a ratio of two measurements;
- c. A logarithmic unit that describes the product of two measurements;
- d. None of the above.

41. Beam spread is greater when using:

- a. High frequency transducers;
- b. Low frequency transducers;
- c. Angle beam transducers;
- d. Larger diameter transducers.

42. The ratio of the normal incidence shear wave transducers is generally below:

- a. -25 dB;
- b. +30 dB;
- c. -30 dB;
- d. None of the above.

43. In UT inspection on a curved surface, what piece of equipment can be used to improve coupling?

- a. A spherically focused transducer;
- b. A cylindrically focused transducer;
- c. A shaped shoe is necessary;
- d. A large diameter transducer.

44. An Eddy current test circuit will have:

- a. Resistance;
- b. Inductive reactance;
- c. A small amount of capacitance;
- d. All of the above.

45. The most common type of defect found in a structure when it is undergoing service is:

- a. Fatigue cracking;

- b. Crystallization;
- c. Weld decay;
- d. Stress fracture.

46. Generation of Eddy currents depends on the principle of:

- a. Wave guide theory;
- b. Electromagnetic induction;
- c. Magneto-restrictive forces;
- d. All of the above.

47. Eddy currents concentrate near the surface adjacent to an excitation coil and their strength:

- a. Decreases with distance from the coil;
- b. Increases with distance from the coil;
- c. Both a and b;
- d. None of the above.

48. When attempting to locate flaws with Eddy Current:

- a. Should be as high as possible;
- b. Should be as low as possible;
- c. A frequency is often selected with the expected flaw depth within a standard depth of penetration;
- d. Depends only on the material conductivity.

49. Undercut is the loss of resolution at a sharp, thickness transition area due to:

- a. Scattering within the part;
- b. Back scatter;
- c. Side scatter;
- d. Scattering within the film.

50. Unexposed X-ray film is comprised of a plastic, transparent base coated with an emulsion containing radiation-sensitive particle, known as:

- a. Flexible, transparent, blue-tinted base;
- b. Contain silver halide crystals;
- c. Both a and b;
- d. None of the above.

51. In radiography, the image quality indicators (IQIs) provide information about the level of:

- a. Contrast sensitivity only;
- b. Resolution and contrast sensitivity;
- c. Resolution and film latitude;

d. Contrast sensitivity and latitude.

52. In RT, geometric unsharpness refers to:

- a. Radioactive decay;
- b. Distance from the source;
- c. The size of the source;
- d. Loss of definition that is the result of geometric factors of the radiographic equipment.

53. Two of the more common industrial Gamma-ray sources are:

- a. Cobalt-60 and iridium-192;
- b. Cobalt-60 and plutonium-240;
- c. Plutonium-240 and uranium-222;
- d. Iridium-192 and Lead-102.

54. By ASME, austenitic stainless steels grades 304, 316, 317, and 347 (Group 1) have been assigned as P-Number:

- a. P- No. 8;
- b. P- No. 5C;
- c. P- No. 6;
- d. P- No. 7.

55. Using x-ray testing, the filters consist of:

- a. Reduce the radiation beam spread;
- b. Material placed in the useful beam to absorb, preferentially, radiation;
- c. Increase film latitude;
- d. Decrease film latitude.

56. In X-ray inspection, the quality of a radiographic image is assessed by the:

- a. Density of the film;
- b. IQI indicator;
- c. KVA available;
- d. Stand-off distance.

57. The family of hardness tests that uses both a minor and major load is called:

- a. Brinell;
- b. Vickers;
- c. Rockwell;
- d. Knoop.

58. What heat treatment is characterized by holding the part at the austenitizing temperature for some time and then slow cooling in the furnace?

- a. Normalizing;
- b. Quenching;
- c. Annealing;
- d. Tempering.

59. Sand inclusions and dross are:

- a. Areas with distinct jagged boundaries;
- b. Nonmetallic oxides, which appear on the radiograph as irregular, dark blotches;
- c. Distribution of very fine lines or small elongated cavities that may vary in density;
- d. None of the above.

60. Detection, conversion and interpretation of elastic waves to electrical signals are the basis of:

- a. Remote Field Testing (RFT);
- b. Phased Array Testing (PA);
- c. Acoustic Emission Testing (AE);
- d. Magnetic Flux Leakage (MFL).

61. Tube wall Remote Field Testing or "RFT" is:

- a. Vibrothermograph or Thermo-sonic testing for detection of welding cracks;
- b. A step-like displacement waveform function, associated with the source process;
- c. Used to inspect ferromagnetic tubing, since conventional Eddy current techniques have difficulty in inspecting the full thickness of a tube wall, due to the strong skin effect in ferromagnetic materials;
- d. The flow of heat from the surface of a solid is affected by internal flaws such as disbands, voids or inclusions.

62. Phased Array Ultrasonics (PA) is:

- a. A high frequency sound energy to conduct examinations, used for flaw detection/evaluation;
- b. An advanced method of ultrasonic testing beam array that has applications in medical imaging, non-invasively heart examination, or to find flaws in manufactured materials such as welds;
- c. An electronic device that can produce high voltage electrical pulses that generates a high frequency ultrasonic energy;
- d. None of the above.

63. Time-of-Flight Diffraction (TOFD) is:

- a. Is another method of ultrasonic testing, more sensitive and accurate for the nondestructive testing of welds;
- b. Is merely a method of generating and receiving ultrasound;

- c. Permit to combine electronic scanning, sectorial scanning, and precision focusing to give a practical combination of optimum angles;
- d. Commonly use strong backscatter tip-diffraction signals to become apparent.

64. Internal Rotary Inspection System (IRIS) is:

- a. A thermoelectric method that responds to properties, composition and mechanical properties;
- b. Another ultrasonic method for evaluation of internal pitting and wall loss, as a nondestructive testing of pipes and tubes, since the quality of pipes diminishes after a while;
- c. For verifying the effectiveness of heat treatment, involving off-grade and mixed-grade materials;
- d. None of the above.

65. In automation, PIG is a device that travels inside a pipeline to clean or inspect. This special technique is indicated for:

- a. Detecting materials "crack-like" or "type flaws" and "far-side flaws";
- b. Evaluating metal loss due to pitting or corrosion in oil-storage tanks or underground steel pipes;
- c. Application of sensitive chemicals to indicate the metal quality and presence of alloying elements.
- d. Both a and b.

66. The Magnetic Flux Leakage technique (MFL), the Guided Wave Testing (GWT) and the Industrial Computed Tomography (CT), are respectively techniques for:

- a. Inspection of oil-storage tanks, underground steel pipes, inspection of engineering structures, pipelines, visual analysis inside a component in its functioning position or with its assembly;
- b. Inspection of thermal properties of an alloy to characterize alloys, inspection of both ferritic and nonferritic pipes, wall thicknesses, visual analysis inside a component or its functioning position;
- c. Inspect oil-storage tank floors or underground steel pipes; inspect metallic structures, inspection of pipelines; inspect an alloy to quickly and easily characterize many alloys;
- d. All of the above.

67. What is the Level needed for inspecting ferritic and nonferritic pipes, boilers, heat exchangers, and fin-fan tubes, using the IRIS (Internal Rotary Inspection System) method?

- a. Only the Level 1;
- b. IRIS Certified, Level 2 and Level 3;
- c. Any professional with a "testimony of qualification";
- d. The Level 3, even not IRIS certified.

68. The general method for pneumatic testing is:

- a. 1.25 MAWP for materials ASME Section IX - Division 1, and 1.1 MAWP for materials ASME Section VIII - Division 2;
- b. 1.1 MAWP for materials ASME Section VIII - Division 1, and 1.25 MAWP for materials ASME Section VIII - Division 2;

- c. 1.25 MAWP for materials ASME Section VIII - Division 1, and 1.1 MAWP for materials ASME Section VIII - Division 2;
- d. None of the above.

69. Hydrostatic pressure test is:

- a. An agreement between user and manufacturer, for test pressures at any point in a piping system;
- b. A way in which atmospheric tanks, pressure vessels, pipelines, gas cylinders, boilers and valves are tested for strength and leaks through the weld or bolting and can be inspected and repaired;
- c. Only a nominal pressure test in excess for yield strength at the environment temperature;
- d. All of the above.

70. Halide torch test is:

- a. A surface finish test for detecting roughness sensitivity;
- b. An early surface inspection technique involving the rubbing of carbon black on glazed pottery;
- c. A sniffer test, using Freon inert gas mixture introduced into the vessel, up to the design pressure;
- d. When the vessel is pressurized with a mixture of 50% Freon and carbon dioxide or 50% Freon and nitrogen are used.

71. The most common test for detecting defects in welded reinforcing plates, is:

- a. Application of a bubble forming solution, in each piece, inspected of at least 0.15 kgf/cm² (2 psi);
- b. The negative weld pressure testing in joints between the sides of a tank with formation of vacuum;
- c. Usually the application of a bubble forming solution, in each welded reinforcing plates, inspected for at least 0.7 (10 psi) to 1.0 kg/cm² (14.5 psi);
- d. None of the above.

72. The main decibel definition is:

- a. One eighth of a Bel, a logarithmic unit that describes a ratio of two measurements;
- b. One tenth of a Bel, a logarithmic unit that describes a ratio of two measurements;
- c. Only the measuring of sound pressure waves in dB-SPL units;
- d. Used to test and measure the loudness of the sound in Pa and for noise pollution monitoring.

73. The main terms used to describe the vibration movements are:

- a. Magnitude, amplitude and acceleration;
- b. Frequency, amplitude and intensity;
- c. Frequency, amplitude and repetition;
- d. Frequency, amplitude and acceleration.

74. What measurement method for shaft alignment is considered easier and quicker to use?

- a. Laser alignment;

- b. Reverse dial indicator;
- c. Straightedge alignment;
- d. Bare hand alignment.

75. How an Inspector can evaluate a pump drive BHP and what are the methods?

- a. Find the power factor in function of the measured current;
- b. Using a voltmeter and a wattmeter;
- c. Find the performance curve and calculate the BHP using the formula;
- d. All of the above.

76. What is the meaning of NPSH, NPSHr and NPSHa, in case of rotary equipment inspection?

- a. NPSH means Net Positive Suction Height, NPSHr (required) and NPSHa (available);
- b. NPSH means Net Positive Suction Head, NPSHr (required) and NPSHa (available);
- c. NPSH means Net Positive Suction Head, NPSHr (refused) and NPSHa (available);
- d. None of the above.

77. The temperature range for Totally Enclosed Fan Cooled Motors (TEFC) bearing housings is:

- a. Commonly $<120^{\circ}\text{F}$ ($<45^{\circ}\text{C}$);
- b. Commonly $140^{\circ}\text{F} \sim 180^{\circ}\text{F}$ ($60^{\circ}\text{C} \sim 80^{\circ}\text{C}$);
- c. Commonly $175^{\circ}\text{F} \sim 200^{\circ}\text{F}$ ($80^{\circ}\text{C} \sim 90^{\circ}\text{C}$);
- d. None of the above.

78. In a tank inspection, the Instrument Air Leakage diagnostic can detect:

- a. Positive and negative air mass flow, leaks in the actuator or related tubing;
- b. Leaks in piston seals and damaged O-rings;
- c. The actuator pressure and travel deviation from setpoint active interlocks in travel calibration;
- d. Both a and b.

79. In automation inspection, an explosion-proof instrument is:

- a. A type of protection to avoid dust and not allow arcs, sparks, which may cause ignition;
- b. A type of protection that utilizes an enclosure that is capable of withstanding an explosion of a gas or vapor and of preventing the ignition of an explosive gas or vapor that may surround it;
- c. All the above;
- d. None of the above.

80. According to NEC, hazardous areas procedures are classified by:

- a. Hazardous materials, gas in atmosphere and ignitable concentration;
- b. Hydrogen, fuel and combustible process gases;
- c. Class, division, and group;

d. None of the above.

81. Commonly the Welding Inspector knows that commissioning means:

- a. Testing, projects, adjusting and balancing measuring building air and fluid flows;
- b. A systematic process of ensuring that all equipment systems perform interactively according to the contract documents, the design intent and the owner's operational needs;
- c. Achieved ideally by beginning in the pre-design phase with design intent development and documentation, and continuing through design, construction and the warranty period;
- d. Both b and c.

82. What is the meaning of "Hook-up" in commissioning?

- a. Project Requirements and the Acceptance Criteria documented by the Commissioning Team;
- b. Refers to equipment testing, making the connections from the utilities needed for the function controls, checking out instrumentations and verifying accurately if the controls are working, as required;
- c. Is the need to document all steps for LEED purposes and coordinate with other members to add costs to the commissioning work;
- d. None of the above.

83. Identify, respectively, the following ASME Code Sections II, V, and IX:

- a. Section II – Materials; Section V – Nondestructive Examination; IX – Welding and Brazing;
- b. Section II – Power Boilers; Section V - Heating Boilers; IX – Pressure Vessels;
- c. Section II – Materials; Section V – Nondestructive Examination; IX – Power Boilers;
- d. Section II – Nondestructive Examination; Section V – Materials; IX – Welding and Brazing.

84. The ASME Section VIII is divided into the following Divisions:

- a. Two: each Division deals with particular areas;
- b. Three: Division 1 (stress factor of 4); Division 2 (stress factor of 3); Division 3 (up 10,000 psig);
- c. Three: Division 1 (stress factor of 3); Division 2 (stress factor of 4); Division 3 (up 15 psig);
- d. Two: Division 1 (stress factor of 3); Division 2 (above 10,000 psig).

85. The term MAWP refers to:

- a. Minimum allowance for working piping;
- b. Maximum allowance for wall pressure;
- c. Gauge maximum allowable working pressure;
- d. Equivalent water column in pressure vessels.

86. Authorized Inspectors can sign the Data Report and stamp the pressure vessel name plate with:

- a. The “**P**” or “**UP**” symbols;
- b. The “**NB**” symbol;

- c. The “U” or “UM” symbols;
- d. None of the above.

87. Piezoelectricity is a property used by which NDT method?

- a. ET;
- b. UT;
- c. RT;
- d. MT.

88. The metal property that relates to a metal’s deforming without failing is called:

- a. Tensile strength;
- b. Ductility;
- c. Hardness;
- d. Toughness.

89. What type of test uses a weighted pendulum, which strikes a notched test specimen?

- a. Brinnel test;
- b. Fatigue test;
- c. Tensile test;
- d. Charpy impact test.

90. Which of the following test are referred to as microhardness test?

- a. Rockwell;
- b. Vickers;
- c. Knoop;
- d. Answers b and c above.

ANSWERS – MODULE 4

1.d	11.d	21.a	31.b	41.b	51.b	61.c	71.c	81.d
2.b	12.d	22.c	32.c	42.c	52.d	62.b	72.b	82.b
3.b	13.a	23.a	33.d	43.c	53.a	63.a	73.d	83.a
4. c	14.d	24.c	34.b	44.d	54.a	64.b	74.a	84.b
5. a	15.c	25.c	35.c	45.b	55.b	65.d	75.d	85.c
6. a	16.b	26.a	36.c	46.b	56.b	66.a	76.b	86.c
7. c	17.b	27.c	37.c	47.a	57.c	67.b	77.b	87.b
8. c	18.d	28.b	38.d	48.c	58.c	68.c	78.d	88.b
9. b	19.b	29.a	39.b	49.d	59.b	69.b	79.b	89.d
10. b	20.c	30.a	40.b	50.c	60.c	70.d	80.c	90.d