

SQUIRREL CAGE INDUCTION MOTORS

SECTION A

In the following statements one of the suggested answers is best. Place the identifying letter on your answer sheet.

1. The rotor current in a three phase induction motor is:-
 - a) zero, since no supply is connected to the rotor circuit;
 - b) supplied by the d.c. connected to the rotor terminals;
 - c) supplied by the a.c. connected to the rotor terminals;
 - d) induced by the stator field cutting the rotor conductors.

2. A three phase winding will produce an electromagnetic field which:-
 - a) rotates at a constant speed;
 - b) reverses direction each cycle;
 - c) reverses direction each half cycle;
 - d) is stationary and constant in strength.

3. Increasing the frequency of supply to a three phase stator winding will:-
 - a) cause the magnetic field to rotate faster;
 - b) cause the magnetic field to rotate slower;
 - c) increase the strength of the magnetic field;
 - d) increase the number of poles in the stator winding.

4. To reverse the direction of rotation of a rotating magnetic field you must:-
 - a) reverse the connections to alternate pole windings;
 - b) reverse the phase sequence of the supply;
 - c) reverse the connections to the rotor winding;
 - d) reverse the connections to all pole windings.

5. The rotor current in an induction motor is:-
 - a) supplied from the separate rotor supply;
 - b) induced by the rotating magnetic field;
 - c) supplied from the stator supply terminals;
 - d) always the same frequency as the stator supply.

6. The rotor speed of an induction motor is:-
- a) always slightly higher than the speed of the rotating magnetic field;
 - b) always slightly lower than the speed of the rotating magnetic field;
 - c) always the same as the speed of the rotating magnetic field;
 - d) dependant only on the size of the load the motor is driving.
7. A six pole three phase motor on a 50 hertz supply will have a rated speed of about:-
- a) 2,800 r.p.m.;
 - b) 1440 r.p.m.;
 - c) 960 r.p.m.;
 - d) 720 r.p.m.
8. The motor in question 7 will have a slip speed of:-
- a) 200 r.p.m.;
 - b) 60 r.p.m.;
 - c) 40 r.p.m.;
 - a) 30 r.p.m.
9. When a three phase motor is running on no load and one supply conductor is open circuited:-
- a) the motor will stop and then start in the opposite direction;
 - b) the motor will continue to run in the same direction;
 - c) the motor will overload and burn out;
 - d) the motor will stop due to loss of the RMF.
10. When a three phase motor is started with one supply conductor open circuited it will:-
- a) start and run normally;
 - b) not start and may burn out;
 - c) not start, but not burn out;
 - d) start, but the direction of rotation will be random.

SECTION B

Blank spaces in the following statements represent omissions. Write the appropriate information on your answer sheet.

As load on an induction motor increases the speed of the motor will _____(1)_____ and the slip speed of the motor will _____(2)_____.

The speed of the rotating magnetic field in a three phase induction motor depends on the number of poles in the winding and the _____(3)_____.

The strength of the rotating magnetic field in a three phase induction motor is equal to _____(4)_____ times the _____(5)_____ flux produce in one of the phase windings.

The direction that a three phase induction motor rotates depends on the _____(6)_____ of the supply currents.

When an induction motor is driving a load the speed of the motor cannot reach _____(7)_____.

If the windings in a three phase induction motor are connected in delta the current in the conductors supplying the motor would be _____(8)_____ the current in the motor windings.

The stator core of a three phase induction motor is laminated to reduce _____(9)_____ loss and the laminations are made from silicon steel to reduce _____(10)_____ loss.

The stator winding of a three phase induction motor consists of _____(11)_____ identical winding displaced by _____(12)_____ degrees from each other.

The _____(13)_____ induction motor has a short circuited rotor winding.

To change the direction of a three phase induction motor the connections to any two of the _____(14)_____ must be changed.

Either the rotor slots or the stator slots are _____(15)_____ to reduce the noise from a three phase induction motor.

When running on no load the speed of a three phase induction motor is _____(16)_____ synchronous speed.

SECTION C

1. A six pole three phase induction motor is connected to a 60Hz supply and runs at full load at 1050r.p.m. Determine:-
 - a) the synchronous speed of the motor; (1 200 r.p.m.)
 - b) the slip speed of the motor. (150 r.p.m.)

SECTION D

1. Figure 1 represents the stator windings of a three phase induction motor and it's terminal block:-
 - a) Connect the windings to the terminal block using the international standard;
 - b) Connect the terminals of the terminal block so that the motor windings are connected in delta;
 - c) Connect the terminal block to the supply terminals.
 - d) Connect the terminal block of Figure 2 to the supply terminals so that the direction of rotation of the motor in Figure 1 is reversed.

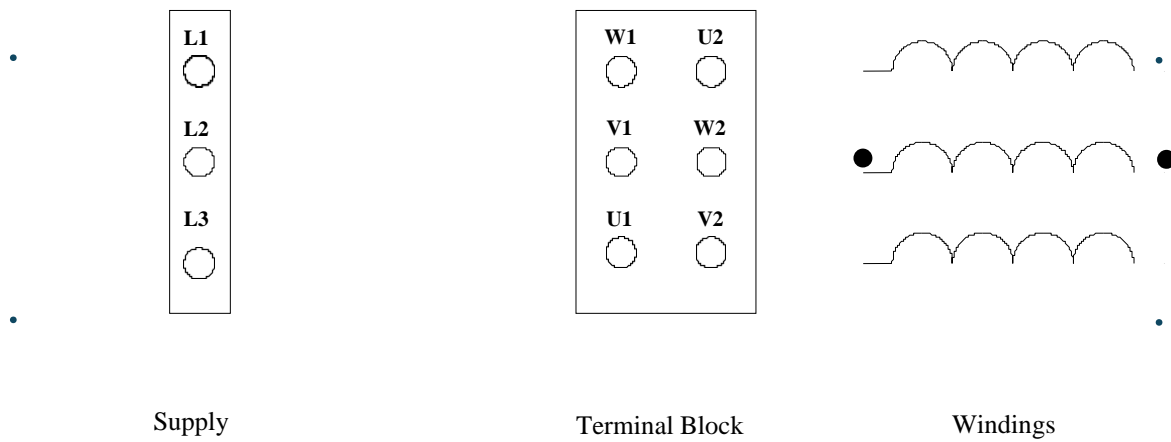

Figure 1.

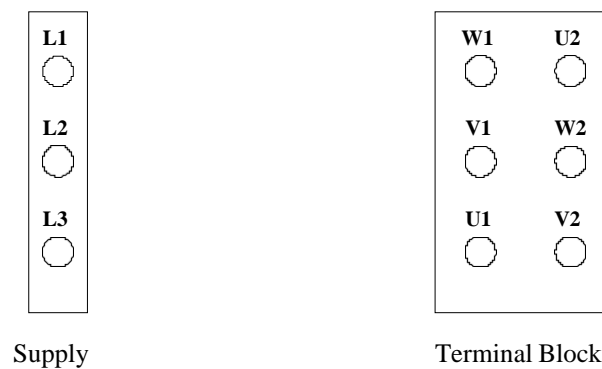

Figure 2.

SLIP-RING INDUCTION MOTORS

SECTION A

In the following statements one of the suggested answers is best. Place the identifying letter on your answer sheet.

1. An advantage of wound rotor induction motors is:-
 - a) high starting current and torque;
 - b) low starting torque with low current;
 - c) low starting current and high starting torque;
 - d) high starting current and low starting torque.

2. The rotor and stator windings of a slip ring induction motor must have the same:-
 - a) number of phases;
 - b) number of poles;
 - c) number of poles and phases;
 - d) connection method (star or delta).

3. The rotor windings of a slip ring induction motor are connected to an external:-
 - a) source of a.c. supply;
 - b) source of d.c. supply;
 - c) variable resistance;
 - d) star delta starter.

4. The rotor and stator windings of a slip ring induction motor are normally connected:-
 - a) rotor in star and stator in delta;
 - b) rotor in delta and stator in delta;
 - c) rotor in star and stator in star;
 - d) rotor in delta and stator in star.

5. The rotor current in a slip ring induction motor:-
 - a) is constant at all loads;
 - b) increases as load increases;
 - c) decreases as load increases;
 - d) varies independent of load.

6. Resistance is added to the rotor circuit of a slip induction motor to:-
- increase torque at lower speeds;
 - reduce current during starting;
 - reduce the speed of the motor;
 - all of the above.
7. An eight pole, 50 hertz slip ring induction motor running at 720r.p.m. with the slip rings short circuited has a slip percent of:-
- 60%;
 - 15%;
 - 6%;
 - 4%.
8. The motor in question 7 will have a slip speed of:-
- 780 r.p.m.;
 - 280 r.p.m.;
 - 60 r.p.m.;
 - 30 r.p.m.
9. A squirrel cage induction motor with a high resistance rotor, compared to one with a lower resistance, would have:-
- a lower full load slip and greater starting torque;
 - a higher full load slip and greater starting torque;
 - a lower full load slip and smaller starting torque;
 - a higher full load slip and smaller starting torque.
10. In a squirrel cage induction motor with dual cage rotor:-
- the inner cage has the higher resistance and carries the greater current at starting;
 - the outer cage has the higher resistance and carries the greater current at starting;
 - the inner cage has the higher resistance and carries the least current at starting;
 - the outer cage has the higher resistance and carries the least current at starting.

SECTION B

Blank spaces in the following statements represent omissions. Write the appropriate information on your answer sheet.

The emf induced in the rotor winding of a slip ring induction motor is a maximum at _____(1)_____.

Adding resistance to the rotor circuit of the slip ring induction motor at starting _____(2)_____ the starting current taken by the motor and _____(3)_____ the available starting torque.

If two of the three leads connecting the slip rings of the slip ring induction motor to its starting resistors are reversed the direction of rotation of the motor will be _____(4)_____.

The unit of torque is the _____(5)_____.

The direction that a three phase induction motor rotates depends on the _____(6)_____ of the supply currents.

When the torque required by the load on an induction motor is increased the speed of the motor _____(7)_____, the slip speed _____(8)_____ the voltage induced in the rotor conductors _____(9)_____, which causes the current in the rotor conductors to _____(10)_____. This causes the strength of the rotor magnetic field to _____(11)_____, which causes the motor output torque to _____(12)_____ to meet the increased load demand on the motor.

The _____(13)_____ induction motor has a wound rotor winding which is always _____(14)_____ connected to allow the connection of _____(15)_____ during starting to _____(16)_____ starting current and _____(17)_____ starting torque.

SECTION C

1. A 4 pole three phase induction motor is connected to a 50Hz supply and runs at a full load slip of 4%. If the motor is delivering 33.16 newton metres of torque to the load at this speed with an efficiency of 83.3 percent and a power factor of 0.86 determine:-
 - a) the synchronous speed of the motor; (1 500 r.p.m.)
 - b) the slip speed of the motor; (60 r.p.m.)
 - c) the rotor speed of the motor; (1440 r.p.m.)
 - d) the output power of the motor; (5kW)
 - e) the input power of the motor; (6kW)
 - f) the line current from the 415 volt supply. (9.71A)

SECTION D

1. Figure 1 represents the incomplete circuit diagram of a three phase slip ring induction motor and it's supply:-
 - a) Connect the stator windings in delta;
 - b) Connect the rotor windings in star;
 - c) Complete the required connections, including the supply and starting resistors, for the motor to start and run.

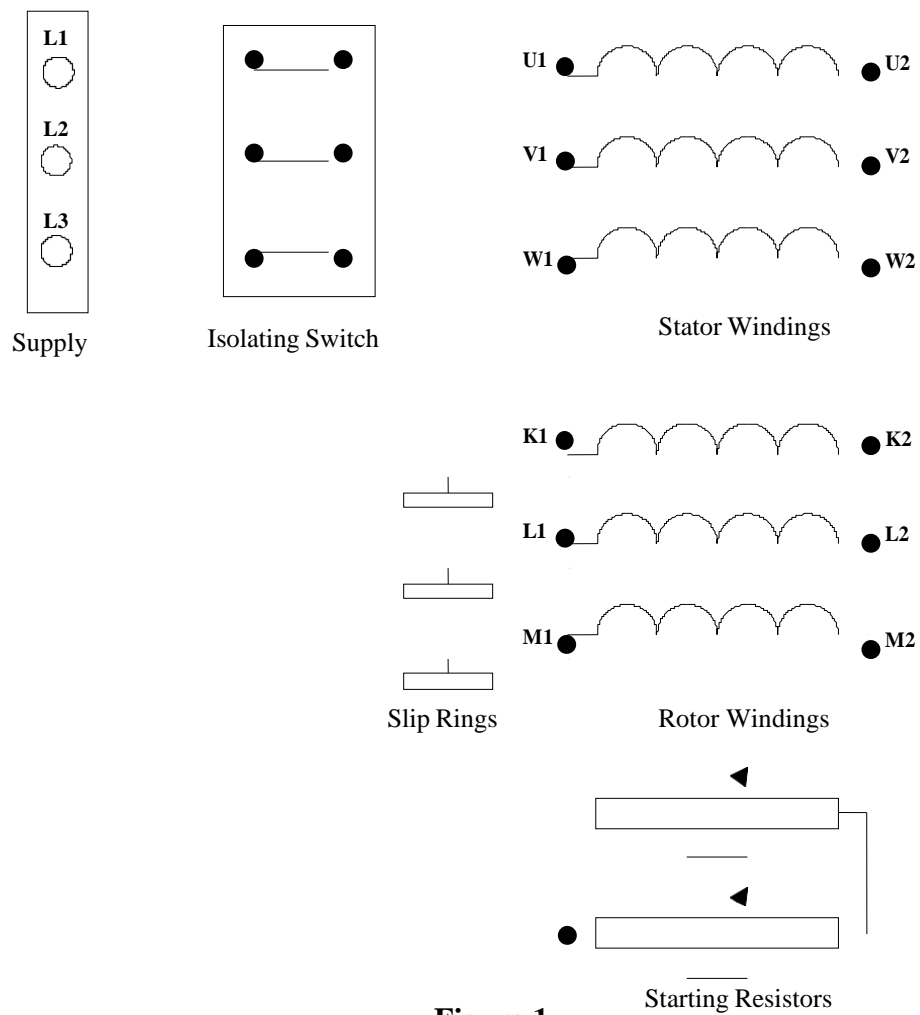

Figure 1.

INDUCTION MOTOR LOAD**CHARACTERISTICS**

SECTION A

In the following statements one of the suggested answers is best. Place the identifying letter on your answer sheet.

1. Copper loss in an induction motor is due to:-
 - a) hysteresis in the stator and rotor cores;
 - b) eddy currents in the stator and rotor core;
 - c) resistance of the stator and rotor windings;
 - d) friction and windage loss in the motor.

2. The efficiency of an induction motor on no load is:-
 - a) 100 percent;
 - b) about 50 percent;
 - c) about 10 percent;
 - d) zero percent.

3. The mechanical losses on no load in an induction motor include:-
 - a) hysteresis in the stator and rotor cores;
 - b) eddy currents in the stator and rotor core;
 - c) resistance of the stator and rotor windings;
 - d) friction and windage loss in the motor.

4. The difference between the input power to a motor and the output power from a motor is the:-
 - a) total loss given off as heat;
 - b) electrical loss given off as resistance;
 - c) mechanical loss given off as friction;
 - d) magnetic loss given off as inductance.

5. An increase in rotor current in an induction motor:-
 - a) reduces stator current to keep stator flux constant;
 - b) reduces power factor due to rotor inductance;
 - c) reduces motor efficiency due to increased losses;
 - d) causes stator current to increase to maintain stator flux.

6. The no load current of an induction motor is shown on a phasor diagram as:-
- the magnetising current and the iron loss current;
 - the rotor current and the stator current;
 - the copper loss current and the iron loss current;
 - the copper loss current and the magnetising current.
7. As the load on an induction motor increases:-
- both the efficiency and the power factor improve;
 - efficiency increases but power factor decreases;
 - efficiency decreases and power factor decreases;
 - efficiency decreases but power factor increases.
8. The stator component of current due to rotor current is:-
- equal to the rotor current and in phase with the rotor current;
 - dependant on the turns ratio and in phase with the rotor current;
 - equal to the rotor current and opposite in phase to the rotor current;
 - dependant on the turns ratio and opposite in phase to the rotor current.
9. Most induction motors are designed to have maximum efficiency:-
- when rotor resistance equals rotor inductive reactance;
 - close to full load as most motors run at this load;
 - at starting to give increased starting torque;
 - at about half of full load as a compromise.
10. In a squirrel cage induction motor:-
- iron losses vary as the square of the load while other losses are almost constant;
 - stator losses vary as the square of the load while other losses are almost constant;
 - rotor losses vary as the square of the load while other losses are almost constant;
 - copper losses vary as the square of the load while other losses are almost constant.

SECTION B

Blank spaces in the following statements represent omissions. Write the appropriate information on your answer sheet.

Copper losses in a squirrel cage induction motor occur in _____(1)_____ while hysteresis and eddy current losses occur in _____(2)_____. Mechanical losses occur due to _____(3)_____ and _____(4)_____.

If voltage and frequency supplying an induction motor remain constant then the _____(5)_____ losses and _____(6)_____ losses remain relatively constant. The variable _____(7)_____ loss varies in proportion to the _____(8)_____.

Maximum efficiency occurs when the _____(9)_____ losses equal the _____(10)_____ losses while maximum torque occurs when the _____(11)_____ equals the _____(12)_____.

If a motor running on full load has some load removed the speed of the motor _____(13)_____ slightly, causing a _____(14)_____ in rotor voltage, a _____(15)_____ in rotor current, a _____(16)_____ in rotor flux and a _____(17)_____ in torque. The motor will settle to a constant speed when _____(18)_____ equals _____(19)_____.

SECTION C

1. A 4 pole three phase 415 volt 50Hz squirrel cage induction motor runs at 1460 r.p.m. while delivering 9 kilowatts to its load at a maximum efficiency of 88 percent. If the power factor of the motor at this load is 0.86 lag determine:-
 - a) the input power to the motor; (10 227W.)
 - b) the line current taken by the motor; (16.55A.)
 - c) the torque delivered to the load; (58.9Nm.)
 - d) the losses in the motor; (1 228W.)
 - e) the copper losses in the motor. (614W.)

2. A 415V squirrel cage induction motor delivers 116 Nm of torque when started on full voltage. The voltage to the motor must be reduced to 320 volts to limit starting current in line with supply authority requirements. Determine the starting torque at the reduced voltage. (69Nm.)

SECTION D

1. Figure 1 is a set of performance curves for a 5kW, 6 pole 415 volt squirrel cage induction motor. From the curves determine:-
 - a) Line current, speed and efficiency at rated load;
 - b) Input power, line current and power factor at no load;
 - c) Speed and efficiency when stator current is 8 amperes.

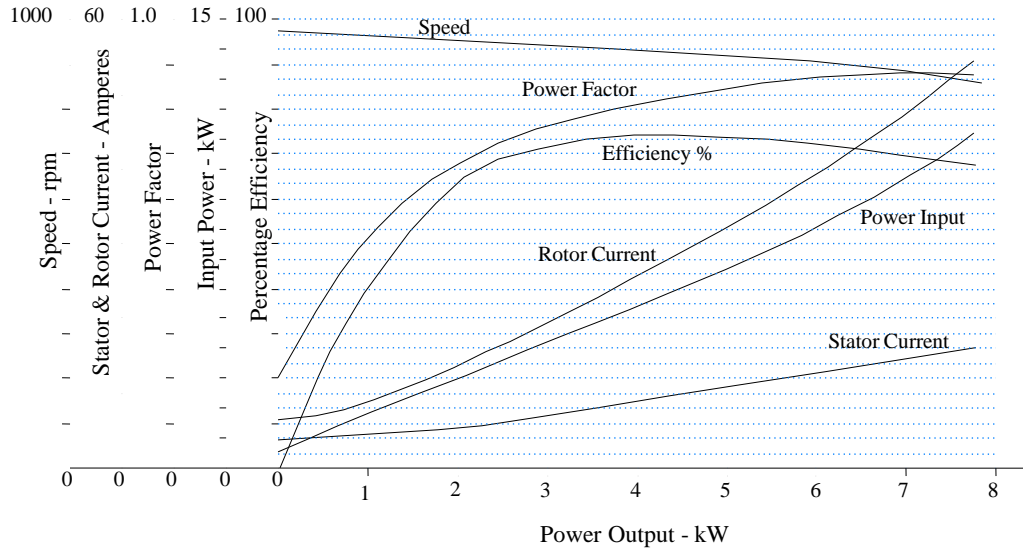
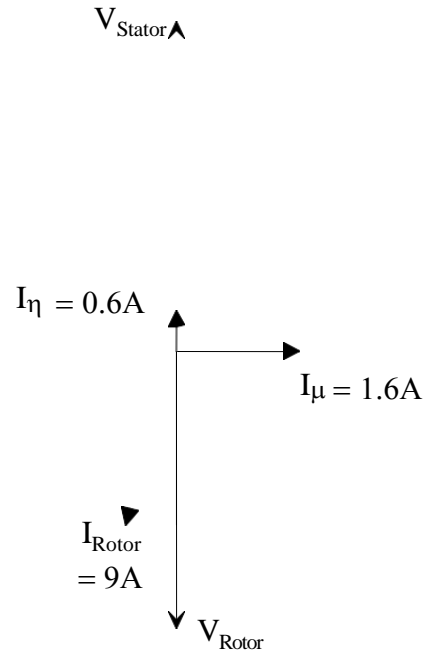

Figure 1

2. Figure 2 is a phasor diagram of a squirrel cage induction motor which shows three components of current in the motor. If the load component of stator current is one third of the rotor current complete the phasor diagram to determine:-

- a) the current scale for the stator currents; (10mm = 1A)
- b) the no load current and power factor; (1.7A @ 0.352lag)
- c) the load component of stator current; (3A @ 16.7°lag)
- d) the total current taken from the supply at this load; (4.26A)
- e) the power factor of the motor at this load. (0.815lag)



Tutorial 10

NAME:

INDUCTION MOTOR STARTING

SECTION A

In the following statements one of the suggested answers is best. Place the identifying letter on your answer sheet.

1. The overload device in a motor starter provides:-
 - a) protection against short circuits inside the motor;
 - b) overload protection for the motor and its supply conductors;
 - c) short circuit protection for the motor supply conductors;
 - d) all of the above.

2. Thermal overloads need to cool after tripping before they can be reset. This is:-
 - a) a problem because the motor cannot be turned back on immediately;
 - b) overcome by using magnetic overloads to allow faster reset times;
 - c) to prevent the circuit breaker at the switchboard from tripping unnecessarily;
 - d) to allow the motor windings to cool before being reconnected to the supply.

3. The motor starter that **does not** reduce the starting current to a squirrel cage induction motor is:-
 - a) the direct on line motor starter;
 - b) the star delta starter;
 - c) the primary resistance starter;
 - d) the auto transformer starter.

4. The main problem with starting large squirrel cage induction motors direct on line is:-
 - a) starting torque is greater if a primary resistance starter is used;
 - b) the large starting current causes fluctuations in the supply voltage;
 - c) the large starting current will cause the motor windings to burn out;
 - d) the motor may not produce enough starting torque to start the load.

5. The problem with starting squirrel cage motors with any of the voltage reduction starters is:-
 - a) the motor must have all six winding ends brought out to the terminal block;
 - b) six wires must be run between the switchboard and the starter;

- c) reducing the voltage causes an even greater reduction in starting torque;
- d) the increased starting torque may damage the load or couplings.

6. The thermal overload used on motor protection:-
- interrupts all overloads very quickly;
 - only isolates short circuits instantly;
 - allows slight overloads for longer periods;
 - takes several minutes to isolate any overload.
7. A motor started with a star-delta starter with overloads fitted between the motor and starter would:-
- require a thermal overload with six bimetallic elements;
 - require an overload current rating equal to rated current times $\frac{1}{\sqrt{3}}$
 - require an overload current rating equal to rated motor current;
 - require an overload current rating equal to rated current times $\sqrt{3}$
8. An advantage of differential thermal overloads over normal overloads is:-
- they can detect the difference between a short circuit and overload fault;
 - they will protect the motor from loss of one phase of the supply;
 - they can be used on single, two or three phase motors;
 - they can also protect against loss of load (ie underload);.
9. Stop buttons and thermal overloads use normally closed contacts because:-
- if they get dirty and will not close the machine will not start (fail safe);
 - normally closed contacts operate quicker than normally open contacts;
 - normally open contacts would need to be connected in parallel;
 - normally closed contacts stay cleaner as the dirt cannot get in.
10. AS/NZS 3000 Clause 4.2.1.2 would be satisfied if:-
- an automatic reclosing overload device protects the motor under all conditions;
 - the isolating switch can be locked in the off position if not located next to the motor;
 - the motor on a saw bench was controlled by a DOL starter operated by pushbuttons;
 - copper losses vary as the square of the load while other losses are almost constant.

SECTION B

Blank spaces in the following statements represent omissions. Write the appropriate information on your answer sheet.

All starters incorporate one or more _____(1)_____ to control the motor and _____(2)_____ to protect the motor from _____(3)_____. At the beginning of the motor circuit (switchboard) either _____(4)_____ or _____(5)_____ are used to provide _____(6)_____ protection for the circuit conductors and the motor.

Starting current to larger motors is required by the _____(7)_____ Authority to be limited to reduce _____(8)_____ in the supply. If this is the case the _____(9)_____ cannot be used. However, one of the _____(10)_____ type starters may be used, depending on current limits and starting torque requirements.

If additional remote pushbuttons are added to a starter all start pushbuttons, which are of the normally _____(11)_____ contact type, are connected in _____(12)_____ and all stop pushbuttons, which are of the normally _____(13)_____ contact type, are connected in _____(14)_____.

When started DOL the starting current of the squirrel cage induction motor is _____(15)_____ to _____(16)_____ times rated current while starting torque is about _____(17)_____ times rated torque. If starting current is reduced the starting torque is reduced in proportion to the _____(18)_____. If the reduction of torque is excessive a _____(19)_____ induction motor may need to be used.

SECTION C

1. A three phase 415 volt 22 kilowatt delta connected squirrel cage induction motor has a rated line current of 45 amperes and a rated full load speed of 1440 r.p.m. If the motor takes six times rated current, and provides 150 percent of full load torque when started direct on line determine:-
 - a) the rated torque produced by the motor; (145.9Nm.)
 - b) the starting current taken by the motor; (270A.)
 - c) the starting torque delivered by the motor; (218.9Nm.)
 - d) the phase current at starting in each winding when connected in delta; (155.9A.)
 - e) the current in each winding, and the line current taken from the supply if they were re-connected in star to the supply. (90A.)
 - f) the starting torque if the motor were connected in star (hint;- torque produced is proportional to **phase** voltage squared, ie $T_2 = T_1 \times \left(\frac{V_2}{V_1}\right)^2$) (72.95Nm)

SECTION D

1. Figure 1 is a Torque - Speed curve for a particular motor which takes 140 amperes from the supply when started direct on line. The supply authority requires the starting current to be reduced to a maximum of 100 amperes. To do this the motor voltage is reduced to 0.7 of normal voltage using resistors in series with the motor at starting (primary resistance starter).
 - a) Calculate the effect that the reduction of starting voltage would have on the starting torque of the motor; (Hint - reduction of torque = (reduction of voltage)²).
 - b) On Figure 1, draw a new Torque - Speed curve for the motor at the reduced voltage. (Hint - the curve will be reduced vertically by the proportion calculated in (a))
 - c) At the reduced voltage would the motor still be able to start:-
 - i. the fan (Load A)?
 - ii. the pump (Load B)?

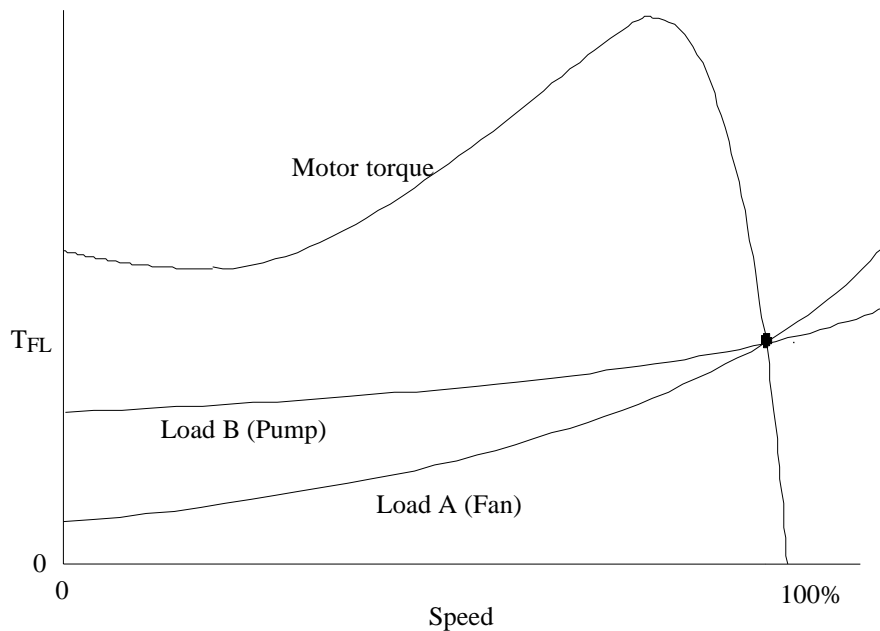

Figure 1

