

TUTORIAL - BASIC ELECTRICAL CONCEPTS

NAME:

Please note the following requirements in relation to tutorial work -

- All tutorial work is to be completed on ruled A4 pad paper, with multiple pages stapled together. Write on one side only of the answer sheets.
- All work is to be completed in ink.
- In the case of multiple choice type questions, the question number and answer letter are to be written on the answer sheet.
- All relevant equations and working are to be shown in the case of calculation type questions.
- All diagrams are to be drawn using appropriate drawing instruments. Drawings are not to be freehand.

SECTION A

In the following statements one of the suggested answers is best. Place the identifying letter on your answer sheet.

1. A domestic electrician works in the:
 - (a) Electrical Industry.
 - (b) Electronics Industry.
 - (c) Supply Industry.
 - (d) Communications Industry

 2. Electricity is transmitted at:
 - (a) high voltage
 - (b) low voltage
 - (c) high current
 - (d) high frequency

 3. An example of the use of renewable energy is:
 - (a) Pulverised Coal
 - (b) LPG gas
 - (c) Solar PV cells
 - (d) Diesel fuel
-

4. An example of the use of non renewable energy is:

- (a) Wind
- (b) Natural Gas
- (c) Geo-thermal
- (d) Hydroelectric

5. Geysers are examples of _____ energy:

- (a) Tidal
- (b) Wind
- (c) Solar
- (d) Geothermal

6. Renewable energy sources:

- (a) Are constantly re-produced by the sun
- (b) Can easily transmitted over long distances
- (c) Are ideal as they all work 24/7 in all weather conditions
- (d) Harm the ozone layer

7. Most renewable energy sources can be traced back to:

- (a) The ozone layer
- (b) Hydro energy
- (c) Nuclear fission
- (d) Solar Energy

8. When coal is burnt to produce electricity a gas is produced that causes global warming. The gas is known as:-

- (a) Carbon dioxide.
 - (b) Ozone.
 - (c) Oxygen.
 - (d) Methane.
-

9. The meter used to measure electric current in a circuit is a:

- (a) ohmmeter
- (b) voltmeter
- (c) ammeter
- (d) megger

10. The opposition to electric current is termed:

- (a) amperes
- (b) voltmeter
- (c) residual
- (d) resistance

11. The unit of electric current is the:

- (a) ampere
- (b) watt
- (c) volt
- (d) ohm

12. If the electric pressure applied to a circuit is increased with the resistance remaining constant electric current will:-

- (a) remain the same
- (b) decrease
- (c) increase
- (d) decrease to zero

13. This question refers to figure 24.. The ammeter method of connection is known as;

- (a) short circuit connection
- (b) series connection
- (c) parallel connection
- (d) open cir

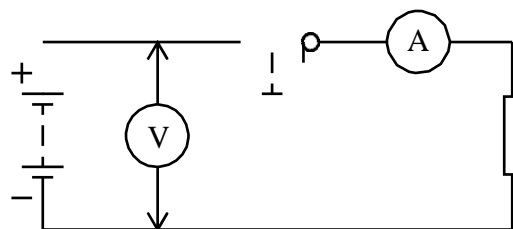

14. This question refers to figure 24. The voltmeter method of connection is known as -

- (a) parallel connection
- (b) short circuit connection
- (c) series connection
- (d) open circuit connection.

15. This question refers to figure 24. Opening the switch in the circuit would have the effect of -

- (a) reducing the circuit resistance.
- (b) reducing the circuit voltage.
- (c) increasing the circuit power.
- (d) stopping the circuit current flow.

16. A battery provides a source of electrical -

- (a) resistance.
- (b) pressure
- (c) displacement.
- (d) conductor

17. The meter used to measure electrical pressure in a circuit is a;

- (a) ohmmeter
 - (b) ammeter
 - (c) wattmeter.
 - (d) voltmeter.
-

SECTION B

18. (3 marks)

Draw the circuit diagram of a lamp supplied by a battery and controlled by a switch. Include an ammeter to measure the circuit current and a voltmeter to measure the battery voltage note the positive and negative terminals of the ammeter and voltmeter.

Convert the following values to both forms of engineering notation **WITHOUT**

using a calculator (you will be able to use your calculator shortly)

Value	Engineering Notation using a power of 10 e.g. 34×10^{-6} Amps	Engineering Notation using a prefix e.g. $34 \mu\text{A}$
32 000 Volts (V)		
600 000 000V0		
.065 V		
0.230 V		
11,000 V		
133kV		
0.000076V		
0.4V		
0.000875mV		
375Amps (A)		
0.025MA		
8350 uA		
485000000000uA		
22500A		
0.09270mA		
0.0194A		
10.5A		
5544332211mA		
22500A		

TUTORIAL - BASIC ELECTRICAL CIRCUITS

NAME: _____

Please note the following requirements in relation to tutorial work -

- All tutorial work is to be completed on ruled A4 pad paper, with multiple pages stapled together. Write on one side only of the answer sheets.
- All work is to be completed in ink.
- In the case of multiple choice type questions, the question number and answer letter are to be written on the answer sheet.
- All relevant equations and working are to be shown in the case of calculation type questions.
- All diagrams are to be drawn using appropriate drawing instruments. Drawings are not to be freehand.

SECTION A

In the following statements one of the suggested answers is best. Place the identifying letter on your answer sheet.

1. The meter used to measure electric current in a circuit is a:

- (a) ohmmeter
- (b) voltmeter
- (c) ammeter
- (d) megger

2. The opposition to electric current is termed:

- (a) amperes
- (b) voltmeter
- (c) residual
- (d) resistance

3. The unit of electric current is the:

- (a) ampere
 - (b) watt
 - (c) volt
 - (d) ohm
-

4. If the electric pressure applied to a circuit is increased with the resistance remaining constant electric current will:-
- (a) remain the same
 - (b) decrease
 - (c) increase
 - (d) decrease to zero

5. This question refers to figure 24.. The ammeter method of connection is known as;

- (a) short circuit connection
- (b) series connection
- (c) parallel connection
- (d) open circuit

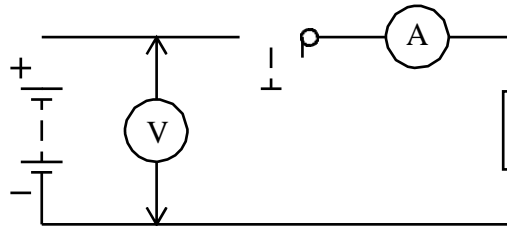

6. This question refers to figure 24. The voltmeter method of connection is known as -

- (a) parallel connection
- (b) short circuit connection
- (c) series connection
- (d) open circuit connection.

7. This question refers to figure 24. Opening the switch in the circuit would have the effect of -

- (a) reducing the circuit resistance.
- (b) reducing the circuit voltage.
- (c) increasing the circuit power.
- (d) stopping the circuit current flow.

8. A battery provides a source of electrical -

- (a) resistance.
 - (b) pressure
 - (c) displacement.
 - (d) conductor
-

9. The meter used to measure electrical pressure in a circuit is a;

- (a) ohmmeter
- (b) ammeter
- (c) wattmeter.
- (d) voltmeter.

SECTION B

10. (3 marks)

Neatly draw the circuit diagram for a lamp supplied by a battery and controlled by a switch. Include an ammeter to measure the circuit current and a voltmeter to measure the battery voltage note the positive and negative terminals of the ammeter and voltmeter.

11. Draw the circuit diagram of a lamp supplied by a battery and controlled by a switch. Include a fuse to protect the circuit, an ammeter to measure the circuit current and a voltmeter to measure the battery voltage.

12. Determine the value and quantity measured on each of the following meters

2: BASIC ELECTRICAL CIRCUITS



(a)

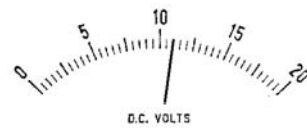

(b)



(c)

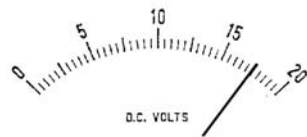

(d)

13. Determine the value and quantity measured on each of the following meters -



(a)

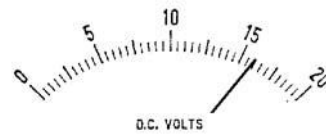

(b)



(c)

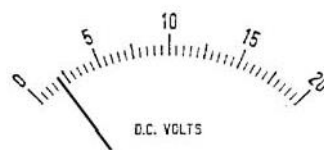

(d)

14. Convert the following number to both formats of Engineering Notation

Number	Convert to a multiple using a power of 10 eg 123×10^3	Convert using a prefix (letters only) 123kV
220000Volts		
844.4Volts		
0.034Volts		
0.008 Volts		
2380 micro Amps		
95 milli Amps		
2400 Amps		
6350 milli Amps		
40000 micro volts		
150000000 Amps		
0.00743258 Volts		
400545486 Amps		
1Volt		
0.194 milli Amp		

TUTORIAL - OHM'S LAW

NAME: _____

Please note the following requirements in relation to tutorial work -

- All tutorial work is to be completed on ruled A4 pad paper, with multiple pages stapled together. Write on one side only of the answer sheets.
- All work is to be completed in ink.
- In the case of multiple choice type questions, the question number and answer letter are to be written on the answer sheet.
- All relevant equations and working are to be shown in the case of calculation type questions.

SECTION A

In the following statements one of the suggested answers is best. Place the identifying letter on your answer sheet.

1. Ohm's Law is only true when:
 - (a) the circuit consists of metallic conductors
 - (b) current and voltage are unequal
 - (c) the voltage exceeds the current
 - (d) circuit conditions are unchanged

 2. If the resistance of a circuit is doubled, the current will be:
 - (a) the same.
 - (b) doubled.
 - (c) halved.
 - (d) decreased

 3. Using the principle of Ohm's Law the resistance of a circuit may be calculated using the equation:
 - (a) $R = \frac{I}{V}$
 - (b) $R = V.I$
-

-
- (c) $R = \frac{V}{I}$
(d) $R = V + I$

4. If the resistance of a circuit is constant and the voltage applied to the circuit increased, the circuit current will:
- (a) fall to zero
(b) decrease
(c) increase
(d) remain unchanged
5. If the voltage applied to a circuit is constant and the resistance of the circuit is increased, the circuit current will:
- (a) remain unchanged
(b) fall to zero
(c) decrease
(d) increase

Section B:

Blank spaces in the following statements represent omissions. Write the appropriate information.

6. The current flowing in a circuit is _____ proportional to the applied voltage and _____ proportional to the circuit resistance.
7. According to Ohm's Law, increasing the applied voltage causes the circuit current to _____.
8. Ohm's Law only applies to resistors with linear characteristics provided the _____ remains constant.
9. When applying Ohm's Law, the voltage applied to a circuit is equal to the product of the _____ and the _____.
-

SECTION C:

The following problems are to be solved with the aid of a calculator. Answers are to be correct to two (2) decimal places.

10. A circuit has an applied voltage of 20V and a resistance of 5Ω . Determine the circuit current. (4A)
 11. A circuit has an applied voltage of 15V and draws a current of 3A. Determine the circuit resistance. (5Ω)
 12. A circuit that has a resistance of 15Ω draws a current of 1.6A. Determine the applied voltage. (24V)
 13. A circuit has an applied voltage of 240V and has a resistance of 5000Ω . Determine the circuit current. (0.048A)
 14. A circuit has the following values: $I = 0.15A$ $R = 150\Omega$
Determine the applied voltage. (22.5V)
 15. A circuit is connected to a DC power supply that is set to 12V. If the resistance of the circuit is 24Ω determine the current flowing in the circuit. (0.5A)
 16. Determine the DC voltage that must be applied to a circuit of 56Ω resistance to cause a current of 0.5A to flow. (28V)
 17. When a 12V battery is connected to a circuit a current of 0.025A flows. Determine the circuit resistance. (480Ω)
 18. A circuit has a current flow of 1.5A when connected to a 12V battery. Determine the current that will flow if the same circuit is connected to a 15V battery. (1.875A)
-

19. A test is carried out on a circuit and the results tabulated as shown in table 3.

Table 3					
Applied Voltage volts	0	3	6	9	12
Circuit Current amperes	0	0.25	0.5	0.75	1

- (a) Draw a graph of the test results using axis as shown in figure 25. Make each axis 100mm long.

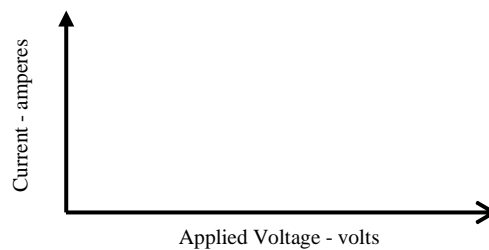
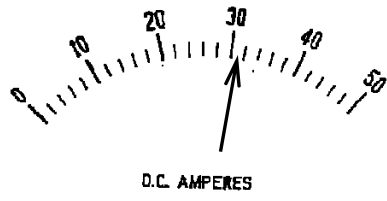

figure 25

- (b) Indicate on your graph the value of current when the applied voltage is -
- (i) 4V
 - (ii) 7.5V
 - (iii) 10.5V
- (c) Is the graph linear or non-linear.
- (d) From your graph determine the voltage applied when the circuit current was -
- (i) 0.2A
 - (ii) 0.4A
 - (iii) 0.8A
- (e) Draw a circuit that will enable you to carry out the above test to achieve this set of test results. Fully label your circuit, including the value of resistance used.
-

20. Determine the value and quantity measured on each of the following meters -



(a)



(b)

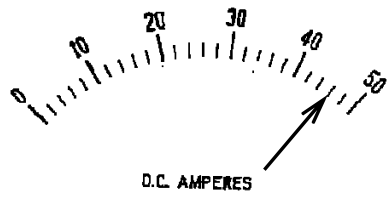

(c)

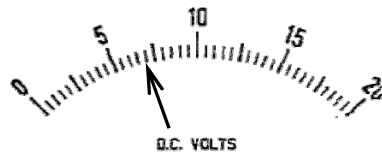

(d)

TUTORIAL - ELECTRICAL POWER

NAME : _____

Please note the following requirements in relation to tutorial work -

- All tutorial work is to be completed on ruled A4 pad paper, with multiple pages stapled together. Write on one side only of the answer sheets.
- All work is to be completed in ink.
- In the case of multiple choice type questions, the question number and answer letter are to be written on the answer sheet.
- All relevant equations and working are to be shown in the case of calculation type questions.
- All diagrams are to be drawn using appropriate drawing instruments. Drawings are not to be freehand.

Section A

In the following statements one of the suggested answers is best. Place the identifying letter on your answer sheet.

The unit of both mechanical and electrical power is the:

- (a) volt
- (b) joule
- (c) watt
- (d) ampere

Power in an electrical circuit is measured using an instrument called the:

- (e) wattmeter
- (f) volt/ammeter
- (g) kilowatt hour meter
- (h) ammeter.

Two electrical instruments whose readings may be combined to determine circuit power are the:

- (i) voltmeter and wattmeter
- (j) ammeter and wattmeter
- (k) ammeter and voltmeter
- (l) wattmeter and kilowatt hour meter

Power is defined as the:

- (m) rate at which work is done
- (n) amount of energy required to do work.
- (o) ability to do work
- (p) heat dissipated when work is done

Electrical equipment is rated in terms of:

- (q) voltage and resistance
- (r) voltage and power
- (s) voltage and current
- (t) power and current.

Mechanical power and electric power are:

- (u) in no way related to each other
- (v) related by a factor of 9.81
- (w) the same.
- (x) measured using different units.

The current in a circuit that is consuming power can be calculated using the equation.

(y)(y) $I = \frac{V}{P}$

(z)(z) $I = \frac{V}{R}$

(aa) $I = P \times V$

(bb) $I = \frac{P}{V}$

If the voltage applied to a resistive circuit was doubled, the power dissipated would:

- (cc) double.
- (dd) decrease to a quarter of the original value.
- (ee) halve.
- (ff) increase to four times the original value.

If the voltage applied to a resistive circuit is halved, the power dissipated will:

- (gg) double.
- (hh) decrease to a quarter of the original value.
- (ii) halve.
- (jj) increase to four times the original value.

The greater the power taken by a circuit from the supply, the:

- (kk) greater the heat dissipated.
- (ll) lower the heat dissipated.
- (mm) lower the work done.
- (nn) cooler the circuit conductors

Section B:

Blank spaces in the following statements represent omissions. Write the appropriate information.

Two electrical instruments whose readings can be combined to determine the power dissipation of a circuit are the _____ and _____.

A wattmeter consists of a _____ coil connected in parallel with the supply and a _____ coil connected in series with the load.

An electric motor converts _____ power to _____ power.

The power dissipated by a resistor is given off in the form of _____

Power is the _____ at which work is done.

When connecting a wattmeter to measure the power taken by a circuit, the current coil is connected in _____ with the load and the voltage coil in _____ with the load.

The terminals of the current coil of a wattmeter are usually labelled _____ and _____, whereas the terminals of the voltage coil are usually labelled _____ and _____.

An electric radiator is rated at 1kW, this means the _____ power to the radiator is 1000 watts.

An electric motor is rated at 5kW, this means the _____ power from the motor is 5000 watts.

SECTION C

The following problems are to be solved with the aid of a calculator. Answers are to be correct to two (2) decimal places. All equations and working are to be shown.

Convert the following quantities to the multiple or sub-multiple required:

0.005 watts to milliwatts (5mW)

130 milliwatts to watts (0.13W)

250 000 watts to kilowatts (250kW)

0.28 megawatts to watts (280 000W)

158 000 watts to kilowatts. (158kW)

A circuit has an applied voltage of 240V and a circuit current of 10A. Determine the circuit power dissipation. (2400W or 2.4×10^3 W or 2.4kW)

A circuit has an applied voltage of 100V and a circuit current of 5A. Determine the power taken by the circuit. (500W)

A circuit has an applied voltage of 6V and has a resistance of 25k Ω . 1. Determine the circuit power dissipation. (0.00144W or 1.44mW or 1.44×10^{-3} W)

A circuit has the following values $R = 12\text{k}\Omega$ $I = 2\text{mA}$. Determine the power supplied. (0.048W or 48mW or 48×10^{-3} W)

Determine the power taken by a circuit that is supplied with a voltage of 110V and draws a current of 2.5A. (275W)

Determine the DC voltage that must be applied to a circuit of 625 Ω resistance to cause a current of 160mA to flow. (100V)

When a 12V battery is connected to a circuit a current of 750mA flows. Determine the power supplied. (9W)

A circuit has a current flow of $5\mu\text{A}$ when connected to a 4.5V battery. Determine the power dissipated. (0.0000225W or $22.5\mu\text{W}$ or $22.5 \times 10^{-6}\text{W}$)

A circuit has a resistance of 1.5Ω and a current flow of 14A. Determine the power taken by the circuit. (294W)

Determine the power dissipated by a 27Ω resistor when connected to a 240V supply. (2133W or 2.133kW or $2.133 \times 10^3\text{W}$)

Draw the circuit diagram of a 12Ω resistor connected to a 240V supply. Include in your diagram a/an –

- (oo) fuse
- (pp) switch to control current flow
- (qq) ammeter to measure circuit current
- (rr) voltmeter to measure the applied voltage
- (ss) wattmeter to measure circuit power consumption.
- (tt) Determine the readings on all three meters.

(V = 240V, I = 20A, P = 4800W or 4.8kW)

TUTORIAL - EMF SOURCES

NAME: _____

Please note the following requirements in relation to tutorial work -

- All tutorial work is to be completed on ruled A4 pad paper, with multiple pages stapled together. Write on one side only of the answer sheets.
- All work is to be completed in ink.
- In the case of multiple choice type questions, the question number and answer letter are to be written on the answer sheet.
- All relevant equations and working are to be shown in the case of calculation type questions.
- All diagrams are to be drawn using appropriate drawing instruments. Drawings are not to be freehand.

SECTION A

In the following statements one of the suggested answers is best. Place the identifying letter on your answer sheet.

1. The magnitude of the emf produced by a photo-voltaic cell depends upon the:
 - (a) size of the electrodes
 - (b) material from which the electrodes are made
 - (c) intensity of light to which it is exposed
 - (d) number of positive and negative electrodes

2. The magnitude of the emf produced at the terminals of a secondary cell depends on the:
 - (a) size of the electrodes
 - (b) material from which the electrodes are made
 - (c) intensity of light to which it is exposed
 - (d) (h)number of positive and negative electrodes

3. The open circuit emf produced by a single dry cell is approximately:
 - (a) 0.5V
 - (b) 1.0V
 - (c) 1.5V
 - (d) 2.0V

4. A common device used to produce a small emf by having two different metals joined to form a junction is called a:
- (a) thermopile
 - (b) thermocouple
 - (c) piezoelectric cell
 - (d) dry cell
5. Certain crystals when placed under mechanical stresses or vibration produce an emf. The effect is called the:
- (a) photoelectric effect
 - (b) thermoelectric effect
 - (c) piezoelectric effect
 - (d) crystalelectric effect
6. A number of thermocouples connected so their emf's add together is termed a:
- (a) thermotank
 - (b) multitherm
 - (c) thermocouple bank
 - (d) thermopile
7. The piezoelectric effect produces electrical energy from:
- (a) light energy
 - (b) heat energy
 - (c) mechanical energy
 - (d) chemical energy
8. Generally speaking the physical size of a cell increases with:
- (a) increase in output current
 - (b) decrease in output current
 - (c) increase in output voltage
 - (d) decrease in output voltage
9. All emf sources are forms of:
- (a) current generators
 - (b) power converters
 - (c) energy converters
 - (d) charge storing devices

10. Solar cells are commonly used to power:

- (a) outback telephones
- (b) spacecraft
- (c) experimental electric cars
- (d) all of the above

SECTION B

Blank spaces in the following statements represent omissions. Write the appropriate information.

- 11. Thecell produces an emf when exposed to light.
 - 12. Theeffect is used to produce an emf in a microphone.
 - 13.are often embedded in the walls of furnaces to detect temperature changes.
 - 14. An emf may be produced by the piezoelectric effect if ais vibrated.
 - 15. A device called a is created where a difference of temperature exists between two junctions of dissimilar metals.
 - 16. A secondary cell is one in which the chemical reactions are
 - 17. The emf per cell of a standard lead-acid battery is approximately volts.
 - 18. The chemical reactions cannot be reversed in a..... cell.
 - 19. A generator produces an emf due to the relative motion between a and a magnetic field.
 - 20. A thermopile consists of two or more connected in series.
 - 21. The electromagnetic effect is used by a..... to produce an emf.
 - 22. The photo-voltaic cell produces an emf when exposed to a source.
-

SECTION C

The following problems are to be solved with the aid of a calculator. Answers are to be correct to two (2) decimal places. All equations and working are to be shown.

23. Convert the following quantities to the multiple or sub-multiple required:

- (a) 0.005 ohms to microhms (5000 $\mu\Omega$)
- (b) 130 milliamperes to amperes (0.13A)
- (c) 250 000 ohms to megohms (0.25M Ω)
- (d) 0.28 megavolts to kilovolts (280kV)
- (e) 158 000 volts to kilovolts. (158kV)

24. A circuit has an applied voltage of 150V and a resistance of 12k Ω . Determine the circuit current. (12.5mA or 12.5 x 10⁻³A)

25. A circuit that has a resistance of 50k Ω draws a current of 1.2mA. Determine the applied voltage. (60V)

26. The equivalent circuit of a battery consisting of 2 x 1.8 volt cells is shown in figure 20. Determine the

- a) developed E.M.F (E)
- b) voltage on internal resistance (V_{R_i})
- c) terminal voltage (E).

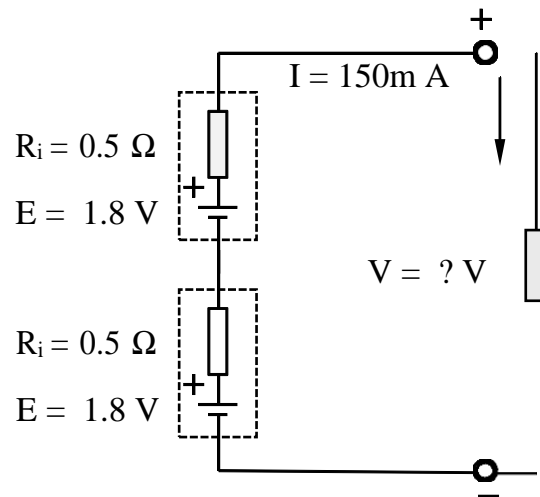

figure 20

27. Determine the voltage drop on resistor R_2 of figure 21. Use the voltage divider equation.

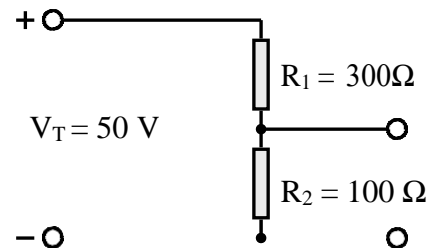

figure 21.

TUTORIAL – RESISTANCE AND RESISTANCE MEASUREMENT

NAME: _____

Please note the following requirements in relation to tutorial work -

- All tutorial work is to be completed on ruled A4 pad paper, with multiple pages stapled together. Write on one side only of the answer sheets.
- All work is to be completed in ink.
- In the case of multiple choice type questions, the question number and answer letter are to be written on the answer sheet.
- All relevant equations and working are to be shown in the case of calculation type questions.

SECTION A

In the following statements one of the suggested answers is best. Place the identifying letter on your answer sheet.

1. Resistors are rated by their value of resistance and the:
 - (a) maximum voltage applicable
 - (b) cross-sectional area of wire from which they are made
 - (c) maximum current flow
 - (d) power able to be safely dissipated

2. A light dependant resistor has a/an:
 - (a) non-linear characteristic
 - (b) linear characteristic
 - (c) constant characteristic
 - (d) inverse characteristic

3. A resistor whose resistance remains constant with changes in external conditions is said to have a/an:
 - (a) non-linear characteristic.
 - (b) linear characteristic
 - (c) constant characteristic.
 - (d) inverse characteristic

4. The resistance of a voltage dependant resistor at normal working voltages is:
 - (a) very high.
 - (b) very low.
 - (c) determined by the circuit power dissipation.
 - (d) determined by the current flow in the circuit

5. The preferred value of a 25000 Ω resistor with a 5 % tolerance is:
 - (a) 22000 Ω .

- (b) 24000Ω .
- (c) $25000\ \Omega$.
- (d) $27000\ \Omega$.

6. A $47\text{ k}\Omega$, 5% resistor would be indicated by the colour band order:

- (a) violet, yellow, green, gold.
- (b) yellow, violet, orange, gold.
- (c) green, blue, red, silver.
- (d) grey, red, green.

7. The number of units in one milli unit is one multiplied by:

- (a) 10^6
- (b) 10^3
- (c) 10^{-3}
- (d) 10^{-6}

8. The basic unit of resistance is the:

- (a) mho
- (b) siemen
- (c) ohm
- (d) ampere

9. The number of units in one micro unit is one multiplied by:

- (a) 10^6
- (b) 10^3
- (c) 10^{-3}
- (d) 10^{-6}

10. The standard unit for the measurement of time is the:

- (a) minute.
- (b) hour.
- (c) second.
- (d) milli second.

11. The number of units in one mega unit is one multiplied by:

- (a) 10^6
- (b) 10^3
- (c) 10^{-3}
- (d) 10^{-6}

12. The standard unit for the measurement of conductance is the:

- (a) siemen.
- (b) ohm.
- (c) ampere.
- (d) milli ohm.

13. The unit for the quantity of electricity is the:

- (a) coulomb.
- (b) volt.
- (c) siemen.
- (d) ampere.

14. A voltage of 1 kV is equal to:

- (a) 0.001V.
- (b) $1 \times 10^{-3}V$
- (c) 1000V
- (d) 0.1V

Section B:

Blank spaces in the following statements represent omissions. Write the appropriate information.

15. The physical difference between a 100Ω , 10W resistor and a 100Ω , 1W resistor is its _____.
16. The resistance of an LDR varies from a high value to a low value as the light falling on the resistor _____.
17. Three common methods of construction of resistors are _____, _____ and _____.
18. A resistor has a resistance of $470W$, with a tolerance of 10%. The colour code for this resistor would be _____, _____, _____ and _____.
19. A resistor has a resistance of $5R6W$, with a tolerance of 1%. The colour code for this resistor would be _____, _____, _____ and _____.
20. A resistor with a gold fourth band would have a tolerance of _____.

SECTION C:

The following problems are to be solved with the aid of a calculator. Answers are to be correct to two (2) decimal places. All equations and working are to be shown.

21. Using the resistor colour code, determine the resistance and tolerance of the resistor shown in figure 23. (2200Ω , $\pm 5\%$).

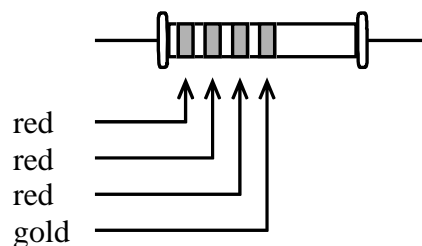

figure 23.

22. Using the resistor colour code, determine the resistance and tolerance of the resistor shown in figure 24. ($680 \Omega \pm 10\%$)

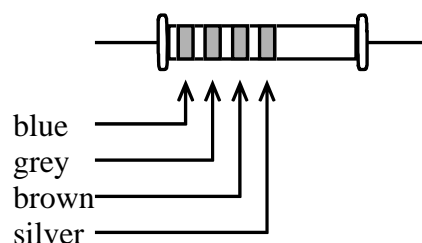

figure 24

23. A resistor has a power rating of 5W and a resistance of 470Ω . Determine the maximum voltage that could be applied to the resistor without exceeding its power rating. (48.47V)
24. Draw the Australian standard symbols for the voltage dependant resistor and the light dependant resistor.
25. Draw the characteristic curve for a light dependant resistor.
26. Draw the characteristic curve for a voltage dependant resistor.
27. List one application for each of the following devices:
 - (a) light dependant resistor
 - (b) voltage dependant resistor
 - (c) thermistor.

TUTORIAL – RESISTANCE AND RESISTANCE MEASUREMENT

NAME: _____

Please note the following requirements in relation to tutorial work -

- All tutorial work is to be completed on ruled A4 pad paper, with multiple pages stapled together. Write on one side only of the answer sheets.
- All work is to be completed in ink.
- In the case of multiple choice type questions, the question number and answer letter are to be written on the answer sheet.
- All relevant equations and working are to be shown in the case of calculation type questions.

SECTION A

In the following statements one of the suggested answers is best. Place the identifying letter on your answer sheet.

28. Resistors are rated by their value of resistance and the:

- (a) maximum voltage applicable
- (b) cross-sectional area of wire from which they are made
- (c) maximum current flow
- (d) power able to be safely dissipated

29. A light dependant resistor has a/an:

- (a) non-linear characteristic
- (b) linear characteristic
- (c) constant characteristic
- (d) inverse characteristic

30. A resistor whose resistance remains constant with changes in external conditions is said to have a/an:

- (a) non-linear characteristic.
- (b) linear characteristic
- (c) constant characteristic.
- (d) inverse characteristic

31. The resistance of a voltage dependant resistor at normal working voltages is:

- (a) very high.
- (b) very low.
- (c) determined by the circuit power dissipation.
- (d) determined by the current flow in the circuit

32. The preferred value of a 25000 Ω resistor with a 5 % tolerance is:

- (a) 22000 Ω .
- (b) 24000 Ω .
- (c) 25000 Ω .

(d) 27000 Ω .

33. A 47 k Ω , 5% resistor would be indicated by the colour band order:

- (a) violet, yellow, green, gold.
- (b) yellow, violet, orange, gold.
- (c) green, blue, red, silver.
- (d) grey, red, green.

34. The number of units in one milli unit is one multiplied by:

- (a) 10^6
- (b) 10^3
- (c) 10^{-3}
- (d) 10^{-6}

35. The basic unit of resistance is the:

- (a) mho
- (b) siemen
- (c) ohm
- (d) ampere

36. The number of units in one micro unit is one multiplied by:

- (a) 10^6
- (b) 10^3
- (c) 10^{-3}
- (d) 10^{-6}

37. The standard unit for the measurement of time is the:

- (a) minute.
- (b) hour.
- (c) second.
- (d) milli second.

38. The number of units in one mega unit is one multiplied by:

- (a) 10^6
- (b) 10^3
- (c) 10^{-3}
- (d) 10^{-6}

39. The standard unit for the measurement of conductance is the:

- (a) siemen.
- (b) ohm.
- (c) ampere.
- (d) milli ohm.

40. The unit for the quantity of electricity is the:

- (a) coulomb.
- (b) volt.
- (c) siemen.
- (d) ampere.

41. A voltage of 1kV is equal to:

- (a) 0.001V.
- (b) 1×10^{-3} V

- (c) 1000V
- (d) 0.1V

Section B:

Blank spaces in the following statements represent omissions. Write the appropriate information.

- 42. The physical difference between a 100 Ω , 10W resistor and a 100 Ω , 1W resistor is its _____.
- 43. The resistance of an LDR varies from a high value to a low value as the light falling on the resistor _____.
- 44. Three common methods of construction of resistors are _____, _____ and _____.
- 45. A resistor has a resistance of 470W, with a tolerance of 10%. The colour code for this resistor would be _____, _____, _____ and _____.
- 46. A resistor has a resistance of 5R6W, with a tolerance of 1%. The colour code for this resistor would be _____, _____, _____ and _____.
- 47. A resistor with a gold fourth band would have a tolerance of _____.

SECTION C:

The following problems are to be solved with the aid of a calculator. Answers are to be correct to two (2) decimal places. All equations and working are to be shown.

- 48. Using the resistor colour code, determine the resistance and tolerance of the resistor shown in figure 23. (2200 Ω , $\pm 5\%$).

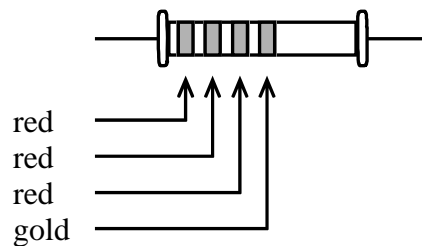

figure 23.

- 49. Using the resistor colour code, determine the resistance and tolerance of the resistor shown in figure 24. (680 $\Omega \pm 10\%$)

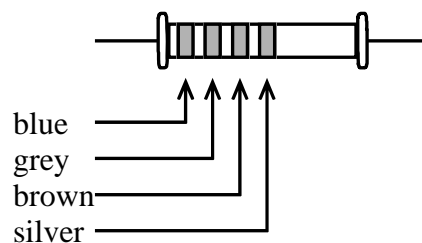

figure 24

- 50. A resistor has a power rating of 5W and a resistance of 470 Ω . Determine the

maximum voltage that could be applied to the resistor without exceeding its power rating. (48.47V)

51. Draw the Australian standard symbols for the voltage dependant resistor and the light dependant resistor.

52. Draw the characteristic curve for a light dependant resistor.

53. Draw the characteristic curve for a voltage dependant resistor.

54. List one application for each of the following devices:

- (a) light dependant resistor
- (b) voltage dependant resistor
- (c) thermistor.

55. A circuit has a current flow of 15A when connected to a 24 V battery. Determine the current that will flow if the same circuit is connected to a 50 V battery. (31.25A)

56. Determine the resistance values indicated on each of the meters shown.

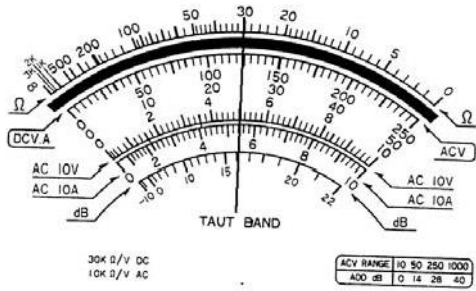

Range: $\Omega \times 1$

(a)

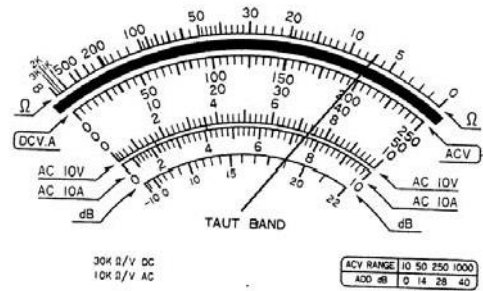

Range: $\Omega \times 100$

(b)

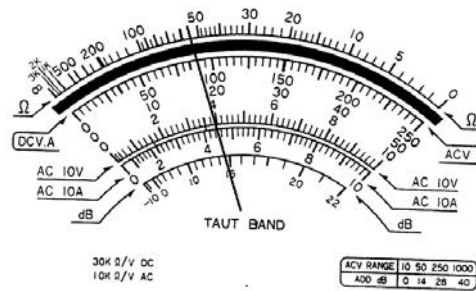

Range: $\Omega \times 10$

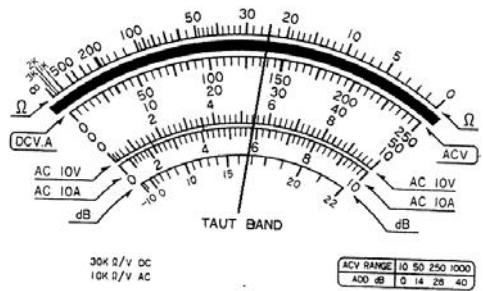

Range: $\Omega \times 100$

TUTORIAL - SERIES CIRCUITS

NAME:

Please note the following requirements in relation to tutorial work -

- All tutorial work is to be completed on ruled A4 pad paper, with multiple pages stapled together. Write on one side only of the answer sheets.
- All work is to be completed in ink.
- In the case of multiple choice type questions, the question number and answer letter are to be written on the answer sheet.
- All relevant equations and working are to be shown in the case of calculation type questions.
- All diagrams are to be drawn using appropriate drawing instruments. Drawings are not to be freehand.

SECTION A

In the following statements one of the suggested answers is best. Place the identifying letter on your answer sheet.

1. In a series circuit the applied voltage is equal to the:
 - (a) sum of the resistance times the current
 - (b) sum of the resistance divided by the current
 - (c) difference of the voltage drops across each resistor
 - (d) sum of the resistances times the current squared

 2. The current in a series circuit is:
 - (a) equal to the sum of the currents in each component.
 - (b) is proportional to the resistance of the circuit.
 - (c) the same in all parts of the circuit.
 - (d) decreases as it gets closer to the negative terminal of the supply.

 3. Connecting resistors in series produces the same effect as increasing the:
 - (a) supply voltage
 - (b) cross-sectional area of resistance wire
 - (c) length of resistance wire
 - (d) supply current
-

4. When five lamps are connected in series and the third lamp burns out:

- (a) lamps one and two go out, but four and five stay on
 - (b) all lamps except the third lamp remain on
 - (c) all lamps go out
 - (d) the fuse blows.
5. The current in a series circuit, consisting of three resistors of equal resistance, is 12A. If two resistors are short circuited the current will then be:
- (a) 36A
 - (b) 4A
 - (c) 12A
 - (d) 0A
6. The voltage drop across each resistor in a series circuit is:
- (a) equal to the product of current squared and resistance
 - (b) proportional to the conductance of each resistor
 - (c) inversely proportional to the supply voltage
 - (d) proportional to the resistance of each resistor
7. The total power in a series circuit may be determined by:
- (a) multiplying total resistance of the circuit by current
 - (b) dividing supply voltage by total resistance
 - (c) subtracting total voltage drop from the supply voltage
 - (d) adding together the power taken by each component
8. Two resistors A and B are connected in series to a 200V supply. If resistor B has three times the resistance of A, the voltage drop across resistor B is:
- (a) 200V
 - (b) 50V
 - (c) 150V
 - (d) 167V
9. A series circuit is defined as a circuit with:
- (a) more than one current path
 - (b) only one current path
 - (c) more than one component
 - (d) more than one supply voltage
10. The equivalent resistance of a series circuit is determined by:
- (a) the sum of the individual resistances
 - (b) the product of the individual resistances

- (c) only by the use of Ohm's law
- (d) the reciprocal of the sum of the reciprocals of the individual resistances

SECTION B

Blank spaces in the following statements represent omissions. Write the appropriate information.

11. The current in all parts of a _____ circuit has the same value.
12. If three cells each having an internal resistance of 0.4Ω are connected in series, the total internal resistance of the battery is _____ ohms.
13. In a series circuit the sum of the voltage drops equals the _____.
14. Two lamps are connected in series across a 240V supply. The voltage across one lamp is 100V. The voltage across the second lamp would be _____.
15. The total power taken by a series circuit is equal to the _____ of the powers taken by the individual components.

Questions 16 to 21 relate to figure 30

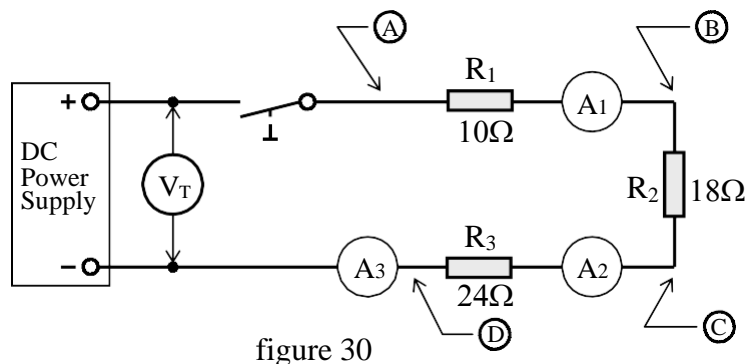

16. The total resistance of a series circuit is equal to the _____ of the individual resistances.
17. The reading on ammeter A1 will _____ the reading on ammeter A3.
18. If the value of the resistor R_2 was decreased, the equivalent circuit resistance would _____.
19. With the switch in the open position, the voltage across the switch would equal _____.
20. Using the negative terminal of the power supply as a reference, complete the following statements

- (a) the voltage at point A would be _____ than the voltage at point C
- (b) the voltage at point D would be _____ than the voltage at point B
- (c) the voltage at point C would be _____ than the voltage at point D
- (d) the voltage at point B would be _____ than the voltage at point C.

21. The power dissipated by resistor R_2 would be _____ than the power dissipated by resistor R_1 .

