

Fully revised & updated second edition

Planning & Installing Solar Thermal Systems



A guide for installers, architects and engineers

Planning and Installing
Solar Thermal Systems

A guide for installers, architects and engineers

Second edition

Planning and Installing
Solar Thermal Systems

A guide for installers, architects and engineers

Second edition



London • Washington, DC

First published in 2010 by Earthscan

Copyright © Deutsche Gesellschaft für Sonnenenergie, 2010

First edition published by James & James (Science Publishers) Ltd in the UK and USA in 2005

All rights reserved. No part of this publication may be reproduced, stored in a retrieval system, or transmitted, in any form or by any means, electronic, mechanical, photocopying, recording or otherwise, except as expressly permitted by law, without the prior, written permission of the publisher.

While the author and publishers believe that the information and guidance given in this work are correct, all parties must rely upon their own skill and judgement when making use of them – it is not meant to be a replacement for manufacturer's instructions and legal technical codes. Neither the author nor the publisher assumes any liability for any loss or damage caused by any error or omission in the work. Any and all such liability is disclaimed.

This book was written using principally metric units. However, for ease of reference by readers more familiar with imperial units, the publisher has inserted these in the text in brackets after their metric equivalents. Please note that some conversions may have been rounded up or down for the purposes of clarity.

Earthscan Ltd
Dunstan House, 14a St Cross Street
London EC1N 8XA, UK

Earthscan LLC
1616 P Street, NW,
Washington, DC 20036, USA

Earthscan publishes in association with the
International Institute for Environment and Development

For more information on Earthscan publications, see www.earthscan.co.uk or write to earthinfo@earthscan.co.uk

ISBN: 978-1-84407-760-1

Typeset by Saxon Graphics Ltd
Cover design by Yvonne Booth

A catalogue record for this book is available from the British Library

Library of Congress Cataloging-in-Publication Data has been applied for.

At Earthscan we strive to minimize our environmental impacts and carbon footprint through reducing waste, recycling and offsetting our CO₂ emissions, including those created through publication of this book. For more details of our environmental policy, see www.earthscan.co.uk.

This book is printed in the UK by Scotprint, an ISO 14001 accredited company. The paper used is FSC certified and the inks are vegetable based.

Contents

Foreword	xi
CHAPTER 1: Solar radiation and arguments for its use	1
1.1 Solar radiation	1
1.1.1 Solar energy	1
1.1.2 Astronomical and meteorological bases	1
1.1.3 Influence of orientation and tilt angle	8
1.1.4 Collection of dust and need for cleaning	10
1.2 The finiteness of energy resources	11
1.3 Climate change and its consequences	13
1.4 Good arguments for solar systems	16
CHAPTER 2: Components of solar thermal systems	17
2.1 How does a solar thermal system work?	17
2.2 Collectors	18
2.2.1 Unglazed collectors	21
2.2.2 Glazed flat-plate collectors	21
2.2.3 Vacuum collectors	30
2.2.4 Collector accessories	34
2.2.5 Collector characteristic curves and applications	35
2.2.6 Stagnation temperature	35
2.3 Heat stores	36
2.3.1 Storage materials	36
2.3.2 Domestic hot water stores	37
2.3.3 Buffer store	40
2.3.4 Combination stores	40
2.3.5 The thermostatic mixing valve	46
2.3.6 Connection of washing machines and dishwashers	46
2.3.7 Legionella contamination	46
2.4 Solar circuit	47
2.4.1 Pipelines	47
2.4.2 Solar liquid	48
2.4.3 Solar pumps	50
2.4.4 Solar heat exchanger (heat transfer unit)	51
2.4.5 Return-flow prevention	52
2.4.6 Rapid air bleeders	52
2.4.7 Flowmeters	54
2.4.8 Safety devices in the solar circuit	54
2.4.9 Solar station	55
2.5 Controller	55
2.5.1 Control principles for temperature difference control	59
2.5.2 Digital controller with special functions	59
2.5.3 Temperature sensors	62
2.5.4 Overheating protection	65
CHAPTER 3: Systems for single-family houses	67
3.1 Introduction	67
3.2 Systems for charging/discharging the store	68
3.2.1 Charging by means of solar energy	68

3.2.2	Charging by means of auxiliary heating	69
3.2.3	Store discharge	70
3.3	Systems for heating domestic water	70
3.3.1	Standard system	70
3.3.2	Water heating using the flow-through principle	71
3.3.3	Water heating by means of tank-in-tank store	71
3.3.4	Water heating over external heat exchanger	71
3.3.5	Drain back system	72
3.4	Systems for heating domestic water and space heating	72
3.4.1	Combined store system (store-in-store system)	73
3.4.2	System with buffer store, internal heat exchanger for heat removal and downpipe	73
3.4.3	Stratified store with hot water heating in once-through flow and heating support	73
3.4.4	Twin store system	73
3.5	Planning and dimensioning	74
3.5.1	Important features for preparing the quotation	74
3.5.2	The dimensioning of systems for domestic water heating	77
3.5.3	Dimensioning of systems for heating domestic water and heating support (central European conditions)	89
3.6	Costs and yields	90
3.6.1	Prices and performance	90
3.6.2	Normalised solar heat costs	94
CHAPTER 4: Installation, commissioning, maintenance and servicing		97
4.1	A brief study of roofing and materials	97
4.1.1	The purpose of the roof	97
4.1.2	Types of roof	97
4.1.3	The components of the roof	98
4.1.4	Pitched roofs	103
4.1.5	Roof installations and mountings	103
4.1.6	Flat roofs	103
4.1.7	Materials	103
4.2	Installation methods and safety	107
4.2.1	UK safety regulations	107
4.2.2	UK personal access and working at heights	108
4.2.3	Working equipment	109
4.2.4	Transport techniques	110
4.2.5	Installation techniques	110
4.3	Installation	111
4.3.1	Delivery of material	111
4.3.2	Setting up the site, preparatory work	111
4.3.3	Collector installation	111
4.3.4	Installation of the solar circuit	126
4.3.5	Store installation	128
4.3.6	Installation of fittings	133
4.3.7	Installation of sensors and controllers	136
4.4	Starting up, maintenance and servicing	136
4.4.1	Flushing out the solar circuit	136
4.4.2	Leak testing	137
4.4.3	Filling with solar liquid	137
4.4.4	Setting the pump and controller	138
4.4.5	Maintenance	138
4.4.6	Detecting and rectifying faults	139

4.5	Information sources for specific countries	146
4.5.1	USA	146
4.5.2	Australia	146
4.5.3	Canada	147
CHAPTER 5: Large-scale systems		149
5.1	The fundamentals of designing the system size	149
5.1.1	Possible application areas	149
5.1.2	Initial data required for planning the solar system	149
5.1.3	System planning and design	150
5.2	Systems	153
5.2.1	Systems with domestic water store(s)	153
5.2.2	Systems with thermal buffer stores	154
5.2.3	Integration of circulation systems	156
5.3	Control of the systems	156
5.3.1	Collector circuit/storage charging circuit	156
5.3.2	Buffer tank circuit discharging	161
5.4	Heat exchangers	162
5.4.1	Design types	162
5.4.2	Collector circuit heat exchangers	164
5.4.3	Buffer tank discharge circuit heat exchangers	165
5.5	Safety technology	168
5.5.1	Collector field	168
5.5.2	Collector circuit	169
5.5.3	Buffer store circuit	170
5.5.4	Expansion vessels	171
5.5.5	Fittings on the domestic water line	171
5.6	Economic considerations	172
5.6.1	Annuity method	172
5.6.2	Types of costs for solar energy systems	173
5.7	Solar contracting	174
5.8	Solar district heating	177
5.8.1	Solar energy systems with short-term heat storage	178
5.8.2	Solar systems with long-term heat storage	178
5.8.3	Guide values for the design of solar district heating systems	179
5.8.4	Components of solar district heating systems	179
5.8.5	Practical experience	181
CHAPTER 6: Solar concentrating systems		183
6.1	Concentration of solar radiation	183
6.2	Concentrating systems providing process heat	184
6.3	Concentrating solar thermal systems for electricity generation	189
6.3.1	Parabolic trough plants	189
6.3.2	Solar tower plants	193
6.3.3	Dish/Stirling systems	195
6.3.4	Economics and outlook	196
CHAPTER 7: Solar heating of open-air swimming pools		197
7.1	Introduction	197
7.2	Components	197
7.2.1	Absorbers	197
7.2.2	Piping and header pipes	201
7.2.3	Materials	202

7.2.4	Pumps, heat exchangers and other components	202
7.2.5	Controllers	204
7.2.6	Covering of the swimming pool	206
7.3	Systems	206
7.3.1	Solar private open-air pool heating	206
7.3.2	Solar heating of public open-air swimming pools	208
7.3.3	Combined solar domestic water heating, open-air pool heating and room heating support	210
7.4	Planning and dimensioning	211
7.4.1	Fundamental considerations	211
7.4.2	Approximation formulae for establishing absorber surface area, volumetric flow and pressure loss	211
7.4.3	Computer-aided system dimensioning	214
7.5	Installation	214
7.5.1	Absorbers	214
7.5.2	Pipeline installation	217
7.6	Operation and maintenance	219
7.7	Costs and yields	219
7.8	Examples	220
7.8.1	Solar heating of a private swimming pool	220
7.8.2	Solar heating of a municipal open-air pool complex	220
CHAPTER 8:	Solar air systems	223
8.1	Introduction	223
8.2	Components	224
8.2.1	Collector types	224
8.2.2	Fans, blowers	229
8.2.3	Piping	230
8.2.4	Heat exchangers and heat recovery units (air/water), recovery-solar-box	230
8.2.5	Control	232
8.3	Systems	234
8.3.1	Central systems, decentralized systems and hybrid systems	234
8.3.2	Further terms of ventilation technology	234
8.3.3	Air collector systems in housing construction	235
8.3.4	Solar drying	239
8.3.5	Factories, halls and office buildings	240
8.4	Planning and dimensioning	242
8.4.1	Fundamental considerations	242
8.4.2	Calculation of required flow rate, required collector surface area and connections of collectors	243
8.4.3	Calculation of fan power	244
8.4.4	Dimensioning of an air-to-water heat exchanger	244
8.4.5	Computer-assisted system sizing	245
8.5	Installation	246
8.5.1	Collector installation	246
8.5.2	Installation of pipelines	248
8.5.3	Positioning of the fan	248
8.6	Costs and yields	248
8.7	Examples	249
8.7.1	Domestic building, Potsdam, Germany	249
8.7.2	Solarwall on General Motors building in Ontario	250

CHAPTER 9: Solar cooling	253
9.1 Introduction	253
9.2 Theoretical bases	255
9.2.1 Overview of thermally driven cooling processes	255
9.2.2 Absorption cooling	255
9.2.3 Adsorption cooling	256
9.2.4 Desiccant cooling system	257
9.3 Integrated planning of solar cooling/air-conditioning systems	259
9.4 System technology	262
9.4.1 Autonomous solar-powered systems versus solar-assisted systems	262
9.4.2 Which collector technology for which cooling technology?	263
9.4.3 Circuit variants	264
9.5 System design	268
9.5.1 General procedure when designing systems	269
9.5.2 System design using empirical values	270
9.5.3 System design according to the peak load	270
9.5.4 Design of autonomous solar-powered systems	271
9.5.5 System design according to primary energy saving	271
9.6 More information	273
CHAPTER 10: Electronic media and software within the area of solar thermal energy	275
10.1 Simulation programs for solar thermal systems	275
10.1.1 Utilization and possibilities of simulation programs	275
10.1.2 Market overview, organization and selection of simulation programs	276
10.1.3 Brief description of simulation programs	277
10.1.4 Evaluation of simulation results	289
10.1.5 Supplementary programs and data sources	289
10.1.6 Tools and utility programs	292
10.2 Materials from manufacturers	294
10.2.1 CD-ROMs, documentation, product catalogues	294
10.2.2 Simulation programs from manufacturers	294
10.3 Internet	294
10.3.1 Internet portals on the topic of solar energy	294
10.3.2 Manufacturer websites	294
10.3.3 Internet-based simulation	294
CHAPTER 11: Marketing and promotion	295
11.1 The fundamentals of solar marketing	295
11.1.1 Customer orientation: the central theme	295
11.1.2 The iceberg principle	295
11.1.3 The 'pull' concept	296
11.2 More success through systematic marketing	296
11.2.1 In the beginning is the benefit	296
11.2.2 The four pillars of the marketing concept	297
11.2.3 The range of marketing options	301
11.2.4 To the goal in six steps	311
11.3 The Soltherm Europe Initiative: European network of solar thermal marketing campaigns	315
11.3.1 Publications	315
11.3.2 Partnership	316
11.3.3 Campaigns and market activities	316
11.3.4 Co-operation	317

11.4	A good sales discussion can be enjoyable	317
11.4.1	What does 'successful selling' mean?	317
11.4.2	Build a bridge	318
11.4.3	Establish need	320
11.4.4	Offer a solution	321
11.4.5	Achieve a result	322
11.5	Subsidies	324
11.5.1	General information on financial support	324
11.5.2	Sources of information in the UK	325
11.5.3	Sources of information in the USA	326
11.5.4	Sources of information in Canada	327
11.5.5	EU sources	328
APPENDIX A: Glossary		329
APPENDIX B: Relevant UK solar regulations and technical standards		335
B.1	General construction regulations	335
B.2	General construction standards	335
B.3	Solar standards	335
B.4	Roof standards	335
B.4.1	Acronyms for roof standards	336
B.5	Working on site, height and lifting regulations	336
APPENDIX C: Nomenclature		337
C.1	Radiation	337
C.2	Heat	337
C.3	Thermal losses	337
C.4	Temperature	337
C.5	Efficiency	337
C.6	Pressure	338
C.7	Material-specific variables	338
C.8	Volume, volumetric flow rate and flow speed	338
C.9	Angles	338
C.10	Surfaces and lengths	338
C.11	System variables	339
C.12	Financing	339
C.13	Constants	339
References and further information		341
Index		343

Foreword

The market for solar thermal systems is growing rapidly. Building owners, planning engineers, architects, fitters and roofers are increasingly being confronted with solar thermal technologies. Large amounts of additional new know-how are being asked for, in particular about the state-of-the-art technology and the actual market situation, and this requires services in consultancy, planning and design, economics and marketing.

This guidebook will complement the services described above and support the decision-making process in offering up-to-date information on the latest technical developments based on best-practice experience. Finally, this guide should work as an aid for high-quality planning and careful system installation.

Highlights of the guide include the following:

- Detailed installation instructions for the large variety of on-site situations.
- Coverage of large solar thermal systems, including solar district heating networks.
- An overview of simulation software.
- Coverage of subjects such as solar swimming pool heating, solar air heating and solar cooling.
- A discussion of practical approaches for successful solar marketing.
- Results of market research giving an overview of the suppliers of solar thermal systems.

1 Solar radiation and arguments for its use

1.1 Solar radiation

1.1.1 Solar energy

The most important supplier of energy for the earth is the *sun*. The whole of life depends on the sun's energy. It is the starting point for the chemical and biological processes on our planet. At the same time it is the most environmentally friendly form of all energies, it can be used in many ways, and it is suitable for all social systems.

In the core of the sun a fusion process takes place in which pairs of hydrogen nuclei are fused into helium nuclei. The energy thus released is radiated into space in the form of electromagnetic radiation. As the sun is 148 million km from the earth, it radiates only a tiny fraction of its energy to the earth. In spite of this, *the sun offers more energy in four hours than the human race uses in a whole year.*

The age of the sun is estimated by astrophysicists to be about 5 billion years. With a total life expectation of 10 billion years the sun will be available as an energy source for another 5 billion years. Hence from our human perspective the sun offers an unlimited life.



Figure 1.1.
The sun: basis of all life on earth

1.1.2 Astronomical and meteorological bases

On the outer edge of the earth's atmosphere the irradiated power of the sun is virtually constant. This irradiated power or radiation intensity falling on an area of one square metre is described as the *solar constant*. This constant is subject to small variations influenced both by changes in the sun's activity (sunspots) and by differences in the distance between the earth and the sun. These irregularities are mostly found in the ultraviolet range; they are less than 5%, and hence not significant in application of the solar constant for solar technology. The average value of the solar constant is given as $I_0 = 1.367 \text{ W/m}^2$ (watts per square metre).

Even based on the astronomical facts alone, the amount of solar energy available on the earth is very variable. It depends not only on the geographical latitude, but also on the time of day and year at a given location. Because of the inclination of the

IRRADIATED POWER, IRRADIANCE, HEAT QUANTITY

When we say that the sun has an irradiance, G , of for example 1000 W/m^2 , what is meant here is the capability of radiating a given irradiated power, ϕ (1000 W), onto a receiving surface of 1 m^2 (10.76 ft^2). The watt is the unit in which power can be measured. If this power is referred, as in this case, to a unit area, then it is called the *irradiance*.

- 1 kW (kilowatt) = 10^3 W (1000 watts)
- 1 MW (megawatt) = 10^6 W (1 million watts) = 10^3 kW
- 1 GW (gigawatt) = 10^9 W (1 thousand million watts) = 10^6 kW
- 1 TW (terawatt) = 10^{12} W (1 million million watts) = 10^9 kW

When the sun shines with this power of 1000 W for 1 hour it has performed 1 kilowatt-hour of work (1 kWh) (Work = Power \times Time).

If this energy were converted completely into heat, a heat quantity of 1 kWh would be produced.

Irradiated power,	ϕ (W)
Irradiance,	G (W/m ²)
Heat quantity,	Q (Wh, kWh)

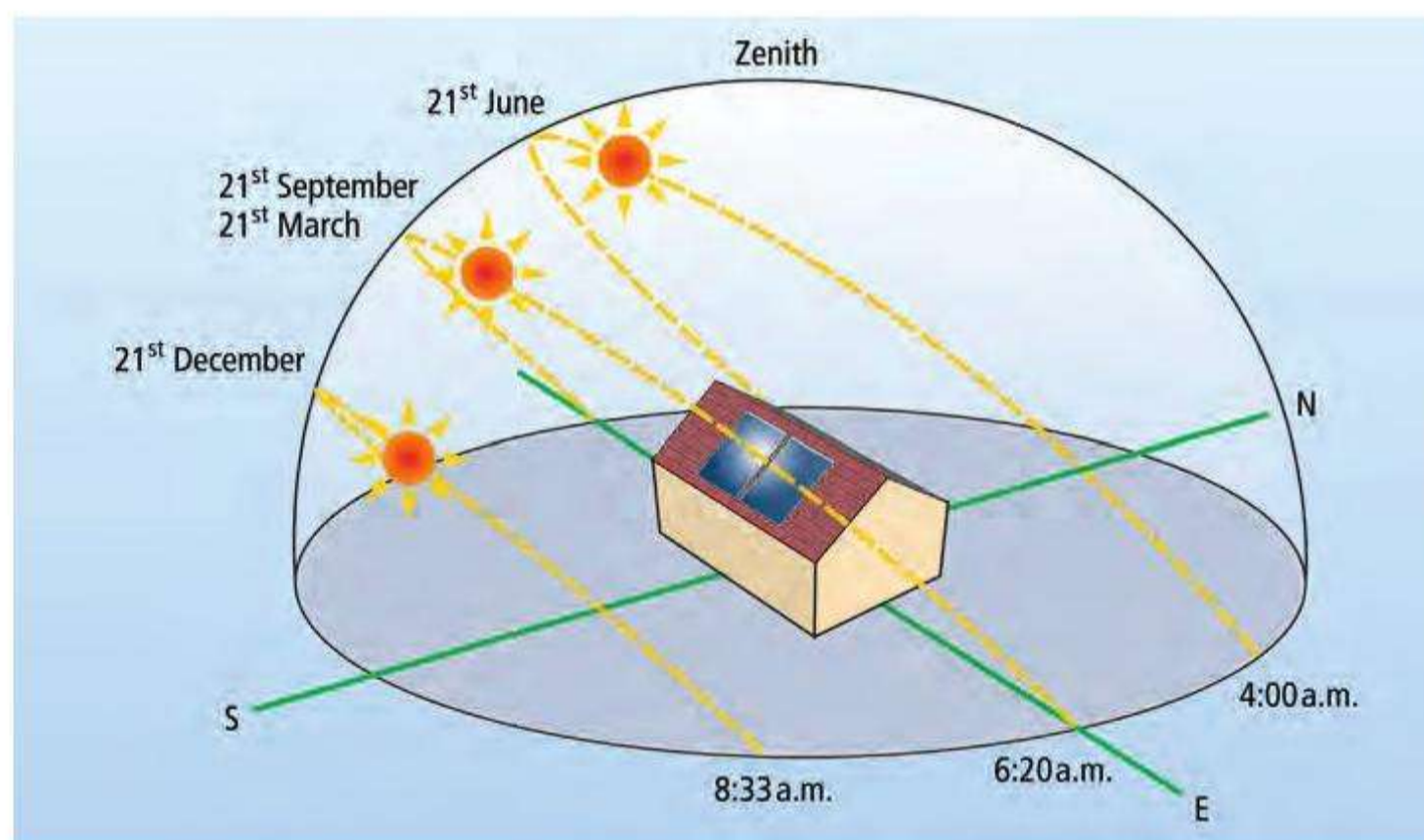

Figure 1.2. The sun's path at different times of the year at central European latitude (London, Berlin)

earth's axis, the days in summer are longer than those in winter, and the sun reaches higher solar altitudes in the summer than in the winter period (Figure 1.2).

Figure 1.3 shows the sequence over a day of the irradiation in London on a horizontal receiving surface of 1 m^2 (10.76 ft^2) for four selected cloudless days over the year. It is clear from the graph that the supply of solar radiation, even without the influence of the weather or clouds, varies by a factor of about ten between summer and winter in London. At lower latitudes this effect decreases in strength, but at higher latitudes it can be even more pronounced. In the southern hemisphere the winter has the highest irradiations, as shown in Figure 1.4, which shows the sequence over a day of the irradiation in Sydney on a horizontal receiving surface of 1 m^2 on three average days over the year.

Even when the sky is clear and cloudless part of the sun's radiation comes from other directions and not just directly from the sun. This proportion of the radiation, which reaches the eye of the observer through the scattering of air molecules and dust particles, is known as *diffuse radiation*, G_{dif} . Part of this is also due to radiation reflected at the earth's surface. The radiation from the sun that meets the earth without any change in direction is called *direct radiation*, G_{dir} . The sum of direct and diffuse radiation is known as *global solar irradiance*, G_G (Figure 1.5).

$$G_G = G_{\text{dir}} + G_{\text{dif}}$$

Unless nothing else is given, this always refers to the irradiation onto a horizontal receiving surface.¹

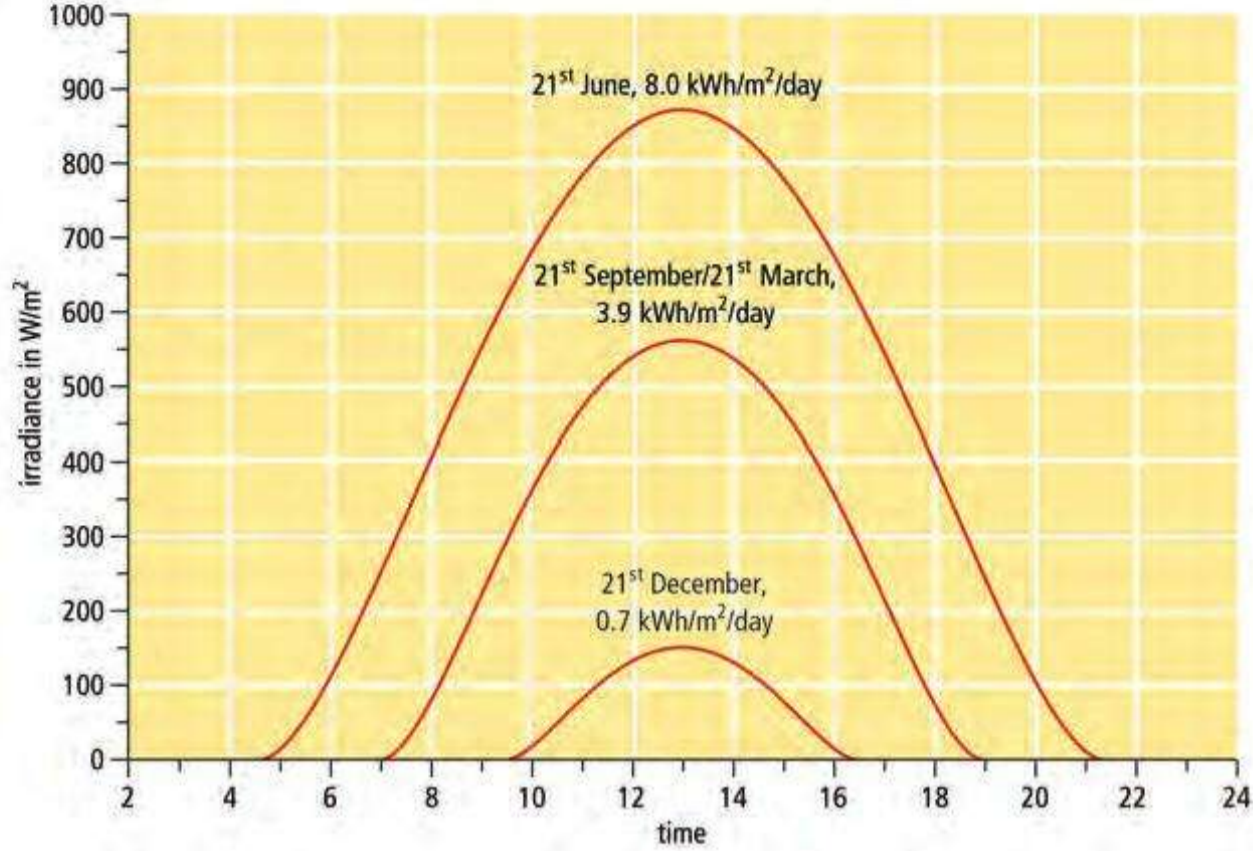

Figure 1.3. Daily courses and daily totals for irradiation in London

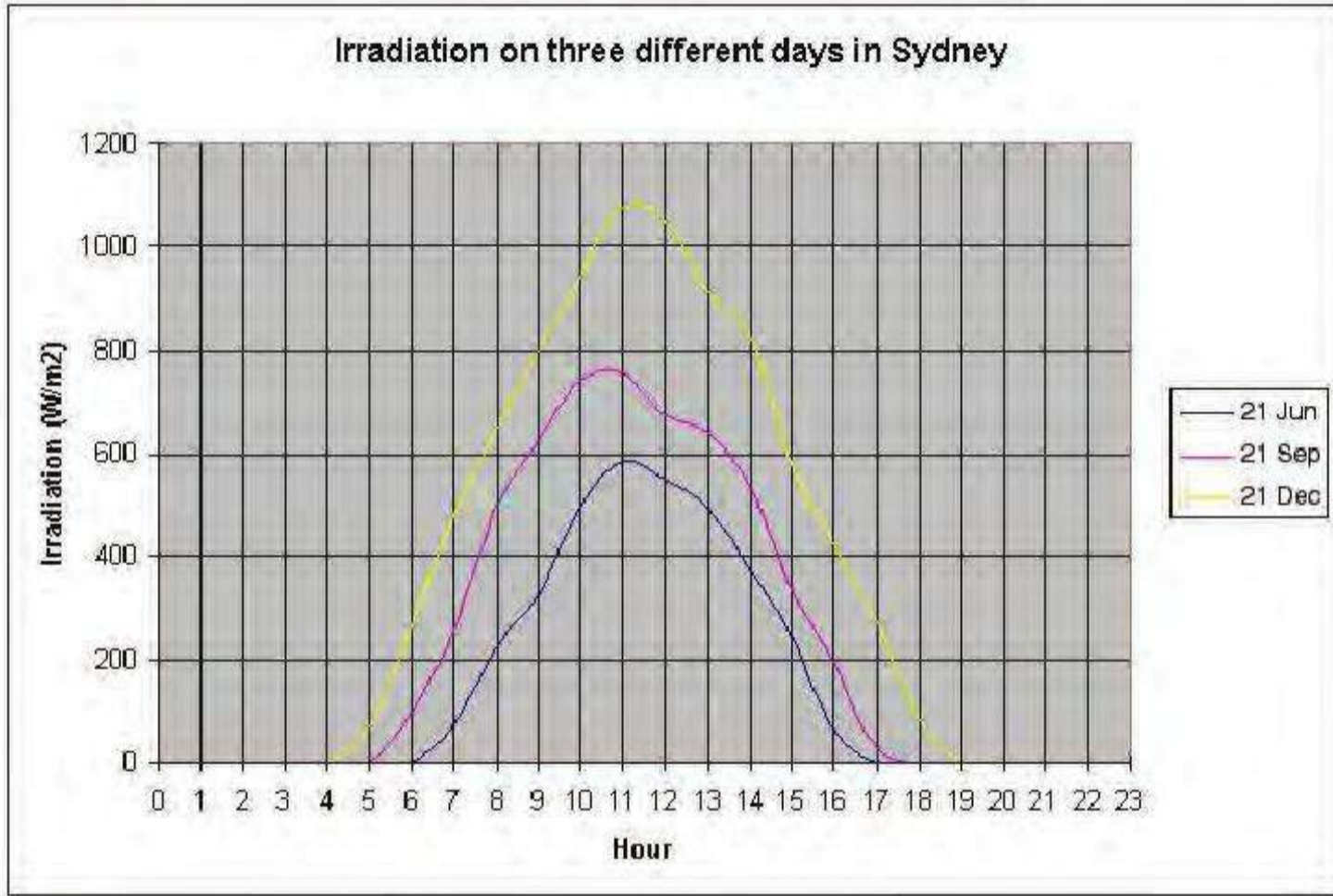

Figure 1.4. Irradiation on three different days in Sydney, Australia

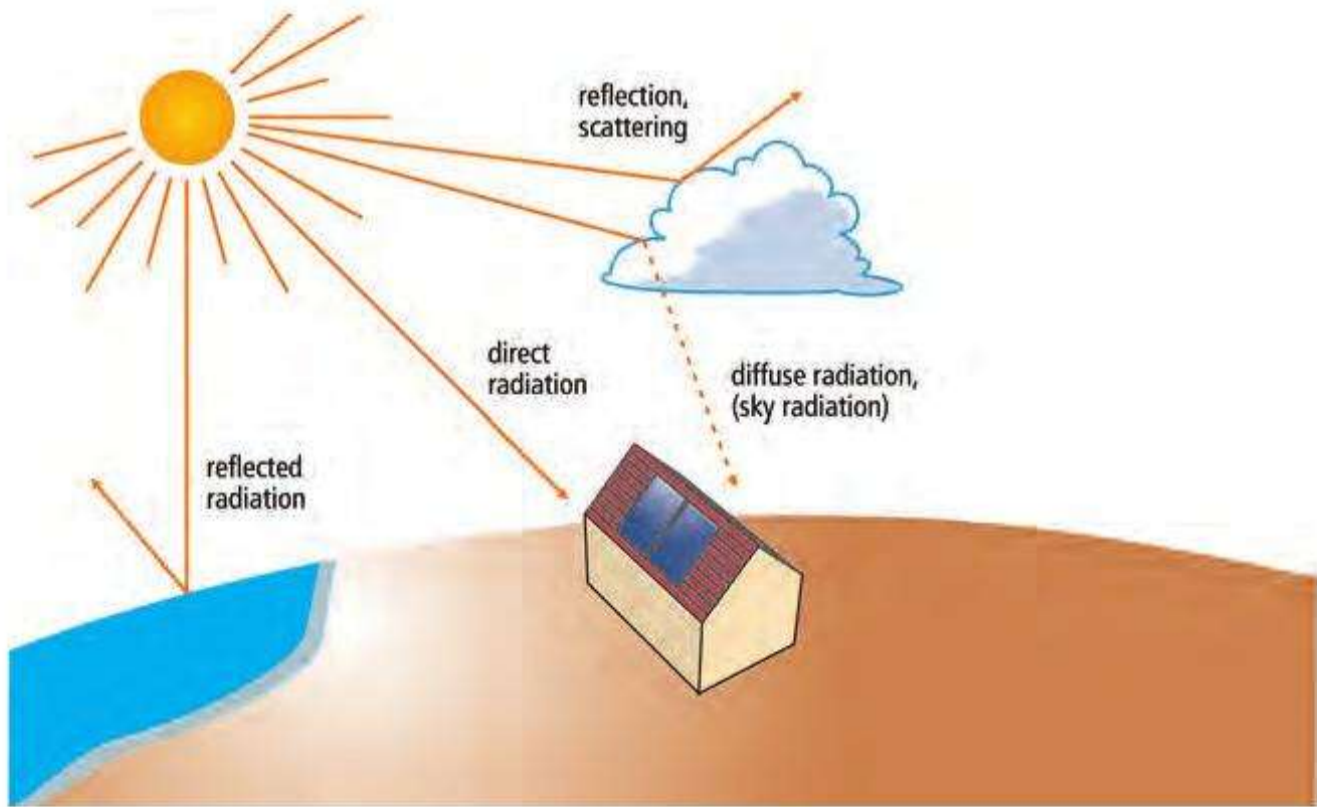

Figure 1.5. Global solar irradiance and its components

When the sun is vertically above a location the sunlight takes the shortest path through the atmosphere. However, if the sun is at a lower angle then the path through the atmosphere is longer. This causes increased absorption and scattering of the solar radiation and hence a lower radiation intensity. The *air mass factor* (*AM*) is a measure of the length of the path of the sunlight through the earth's atmosphere in terms of one atmosphere thickness. Using this definition, with the sun in the vertical position (elevation angle, $\gamma_s = 90^\circ$), $AM = 1$ ($AM = 1/\sin \gamma_s$).

Figure 1.6 shows the respective highest levels of the sun on certain selected days in London and Berlin. The maximum elevation angle of the sun was achieved on 21 June with $\gamma_s = 60.8^\circ$, and corresponded to an air mass of 1.15. On 22 December the maximum elevation angle of the sun was $\gamma_s = 14.1^\circ$, corresponding to an air mass of 4. At lower latitudes, all elevation angles will increase: for example, at a latitude of 32° (north or south), the highest elevation angle will be 80.8° and the lowest angle will be 34.1° .

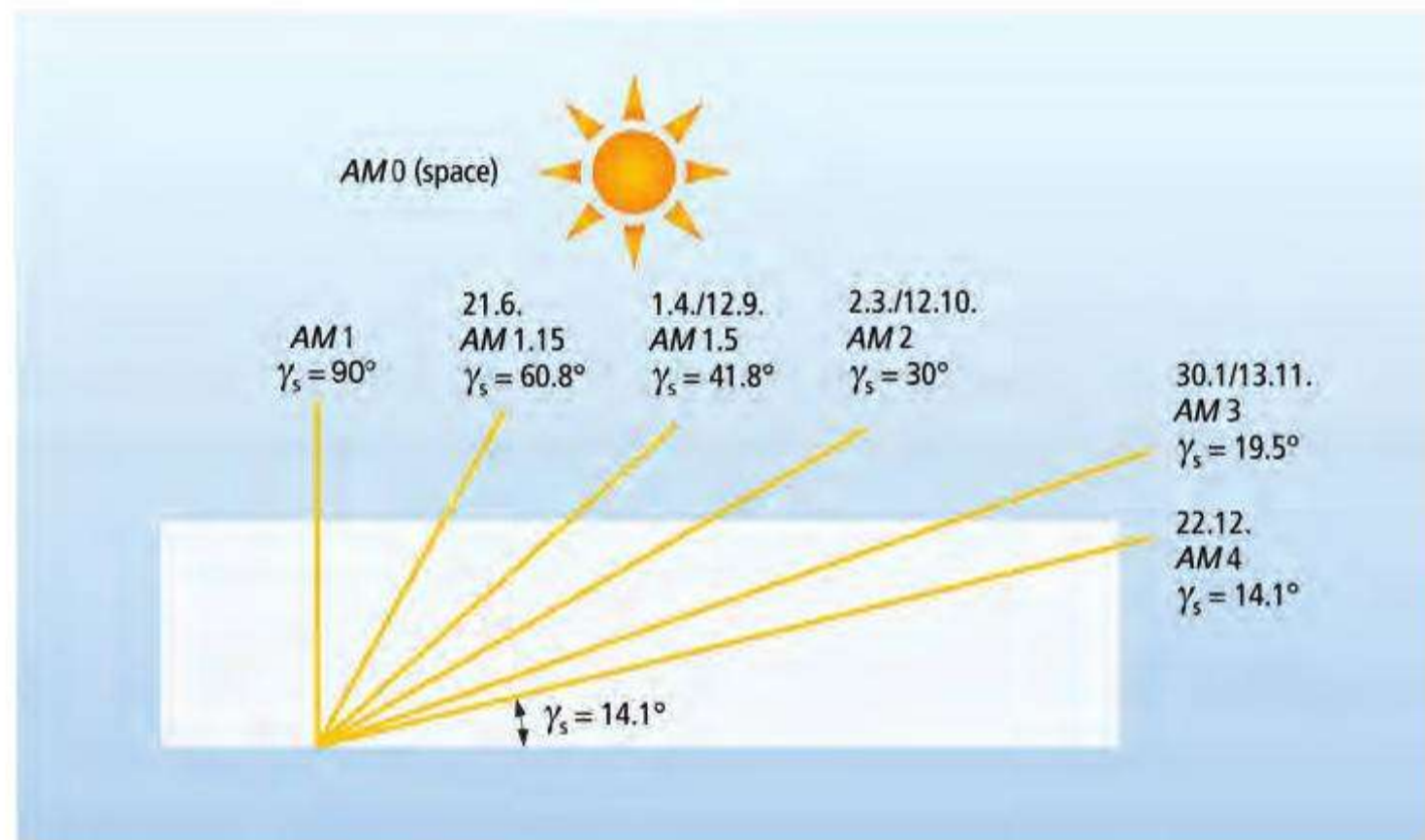

Figure 1.6. Sun's level at midday within the course of a year in London and Berlin (latitude: $52^\circ N$)

The sun's radiation in space, without the influence of the earth's atmosphere, is described as *spectrum AM 0*. As it passes through the earth's atmosphere, the radiation intensity is reduced by:

- reflection caused by the atmosphere
- absorption by molecules in the atmosphere (O_3, H_2O, O_2, CO_2)
- Rayleigh scattering (scattering by the air molecules)
- Mie scattering (scattering by dust particles and contamination in the air).

See Figure 1.7.

Table 1.1 shows the dependence of the irradiation on the elevation angle, γ_s . Absorption and scattering increase when the sun's elevation is lower. Scattering by dust particles in the air (Mie scattering) is heavily dependent on the location. It is at its greatest in industrial areas.

Table 1.1. Effect of elevation angle on attenuation of irradiation

γ_s	AM	Absorption (%)	Rayleigh scattering (%)	Mie scattering (%)	Total attenuation (%)
90°	1.00	8.7	9.4	0–25.6	17.3–38.5
60°	1.15	9.2	10.5	0.7–25.6	19.4–42.8
30°	2.00	11.2	16.3	4.1–4.9	28.8–59.1
10°	5.76	16.2	31.9	15.4–74.3	51.8–85.4
5°	11.5	19.5	42.5	24.6–86.5	65.1–93.8

After the general astronomical conditions, the cloud cover or state of the sky is the second decisive factor that has an effect on the supply of solar radiation: both the irradiated power and the proportions of direct and diffuse radiation vary greatly according to the amount of cloud (Figure 1.8).

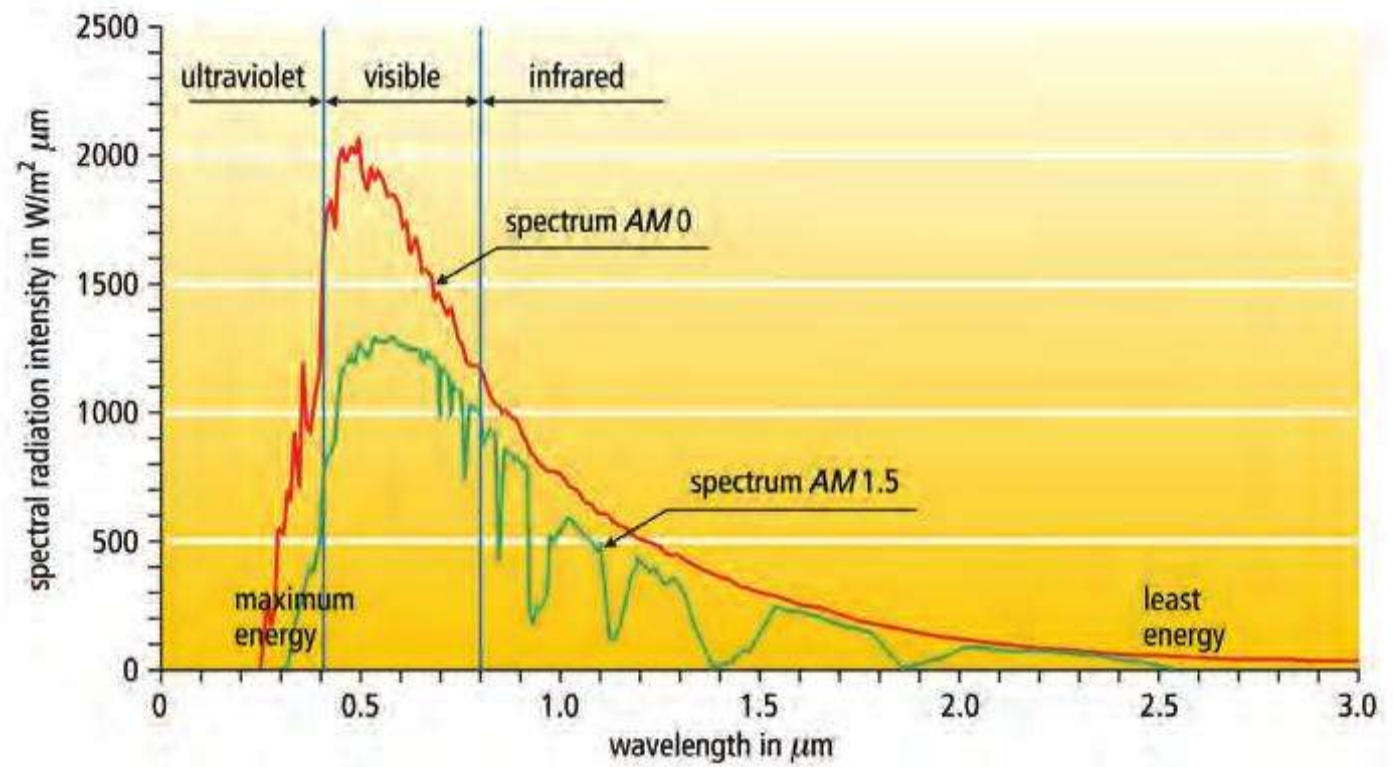

Figure 1.7.
Sun spectrum AM 0 in space and AM 1.5
on the earth with a sun elevation of 41.8°

Over many years the average proportion of diffuse to global solar irradiance in central Europe has been found to be between 50% and 60%. In sunnier climates the fraction of diffuse radiation is lower; in the winter months this proportion is higher. See Figures 1.9a–c.²

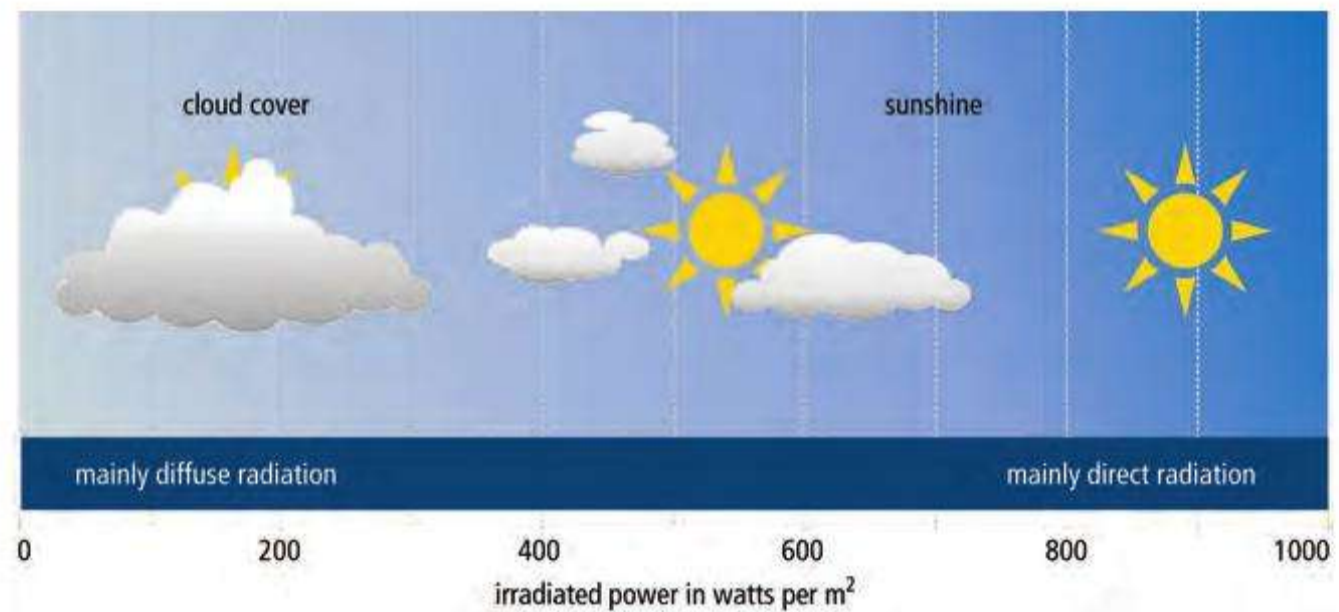

Figure 1.8.
Global solar irradiance and its
components with different sky conditions

The average annual global solar irradiance is an important value for designing a solar plant. It is significantly higher at lower than at higher latitudes, but for climatological reasons severe regional differences can arise. The maps in Figure 1.10 give an indication of the solar irradiance in different regions. Table 1.2 gives an overview of the monthly solar irradiance in a number of cities around the world (measured in kWh/m² per day on a horizontal surface). Over the course of a year global solar irradiance is subject to significant daily variations, especially in climates where cloudiness occurs regularly.

In addition to global solar irradiance, the *sunshine duration* is sometimes given: that is, the number of hours each year for which the sun shines. In the United Kingdom this value varies between 1300 and 1900 hours per year. However, the radiation is a far more reliable figure to use when designing or installing solar energy systems.

Table 1.2.
Solar irradiation (kWh/m² per day)
around the world

City	Jan	Feb	Mar	Apr	May	Jun	Jul	Aug	Sep	Oct	Nov	Dec
Birmingham, UK	0.65	1.18	2.00	3.47	4.35	4.53	4.42	3.87	2.67	1.48	0.83	0.45
Brisbane, AUS	6.35	5.71	4.81	3.70	2.90	2.43	2.90	3.61	4.93	5.45	6.33	6.32
Chicago, USA	1.84	2.64	3.52	4.57	5.71	6.33	6.13	5.42	4.23	3.03	1.83	1.45
Dublin, IRL	0.65	1.18	2.26	3.60	4.65	4.77	4.77	3.68	2.77	1.58	0.77	0.45
Glasgow, UK	0.45	1.04	1.94	3.40	4.48	4.70	4.35	3.48	2.33	1.26	0.60	0.32
Houston, USA	2.65	3.43	4.23	5.03	5.61	6.03	5.94	5.61	4.87	4.19	3.07	2.48
Johannesburg, SA	6.94	6.61	5.90	4.80	4.35	3.97	4.26	5.10	6.13	6.45	6.57	7.03
London, UK	0.65	1.21	2.26	3.43	4.45	4.87	4.58	4.00	2.93	1.68	0.87	0.48
Los Angeles, USA	2.84	3.64	4.77	6.07	6.45	6.67	7.29	6.71	5.37	4.16	3.13	2.61
Melbourne, AUS	7.13	6.54	4.94	3.20	2.13	1.93	2.00	2.71	3.87	5.26	6.10	6.68
New York, USA	1.87	2.71	3.74	4.73	5.68	6.00	5.84	5.39	4.33	3.19	1.87	1.48
Philadelphia, USA	1.94	2.75	3.81	4.80	5.55	6.10	5.94	5.42	4.37	3.23	2.13	1.68
Phoenix, USA	3.29	4.36	5.61	7.23	8.00	8.17	7.39	6.87	5.97	4.84	3.57	2.97
Sydney, AUS	6.03	5.54	4.23	3.07	2.61	2.33	2.55	3.55	4.63	5.87	6.50	6.13
Toronto, CAN	1.58	2.54	3.55	4.63	5.77	6.30	6.29	5.45	4.03	2.68	1.37	1.16
Vancouver, CAN	0.84	1.75	3.00	4.27	6.03	6.50	6.52	5.42	3.80	2.06	1.03	0.65

Figure 1.9. Monthly sum of global solar irradiance (diffuse and direct)

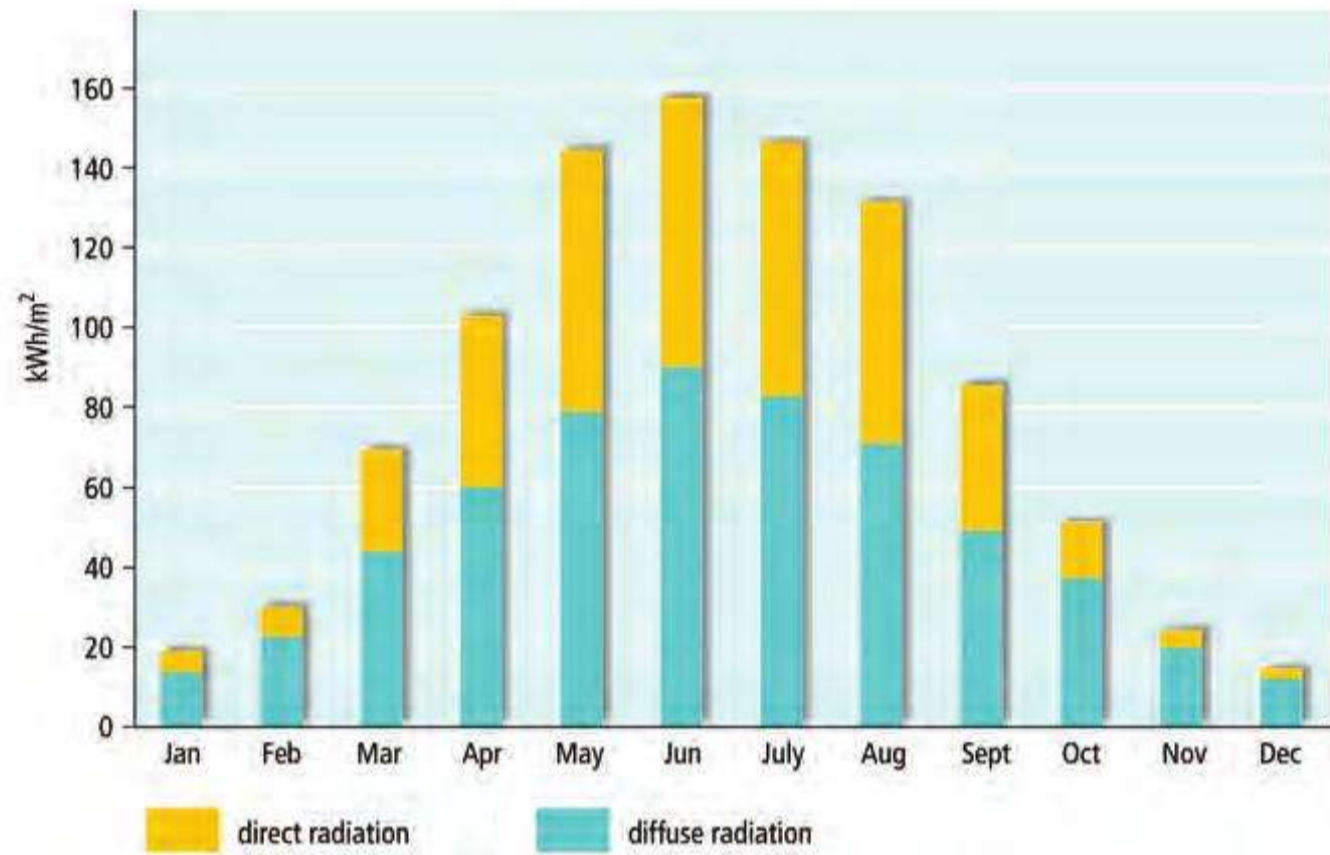

Figure 1.9a.
Berlin, Germany

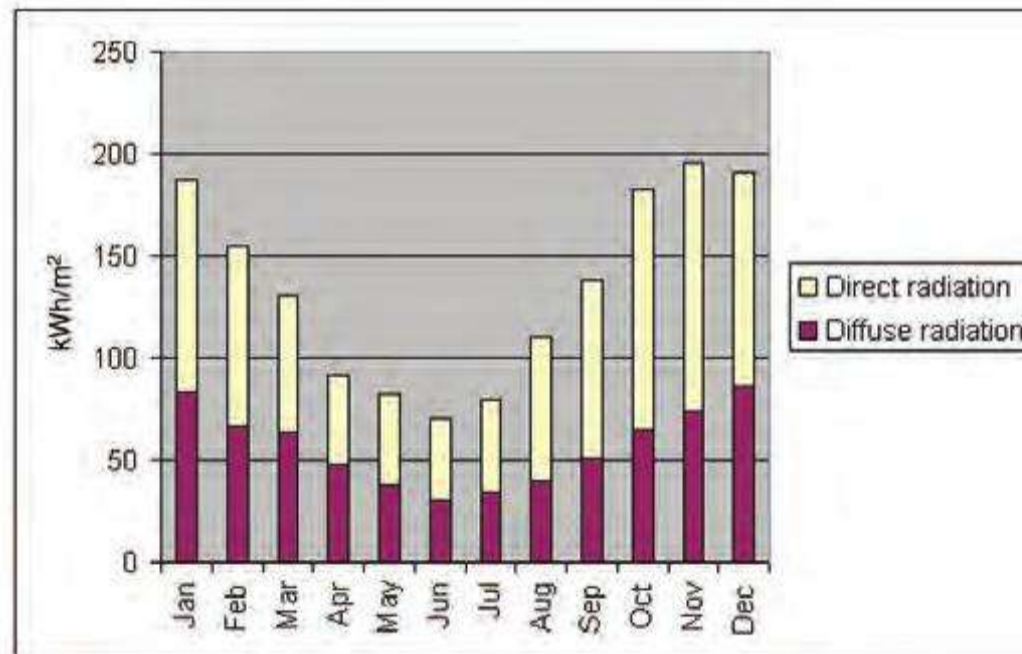

Figure 1.9b.
Sydney, Australia

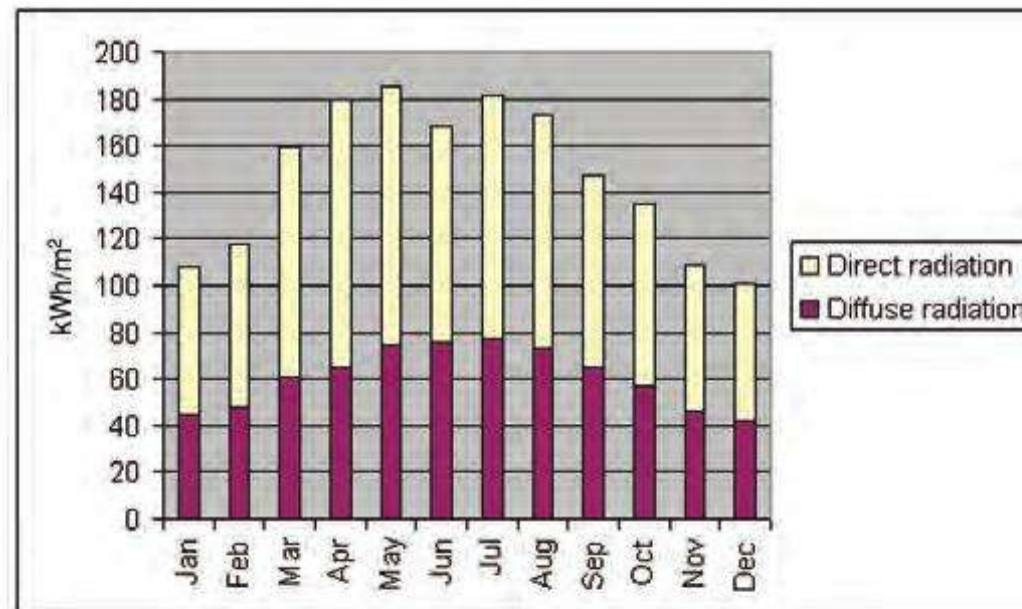
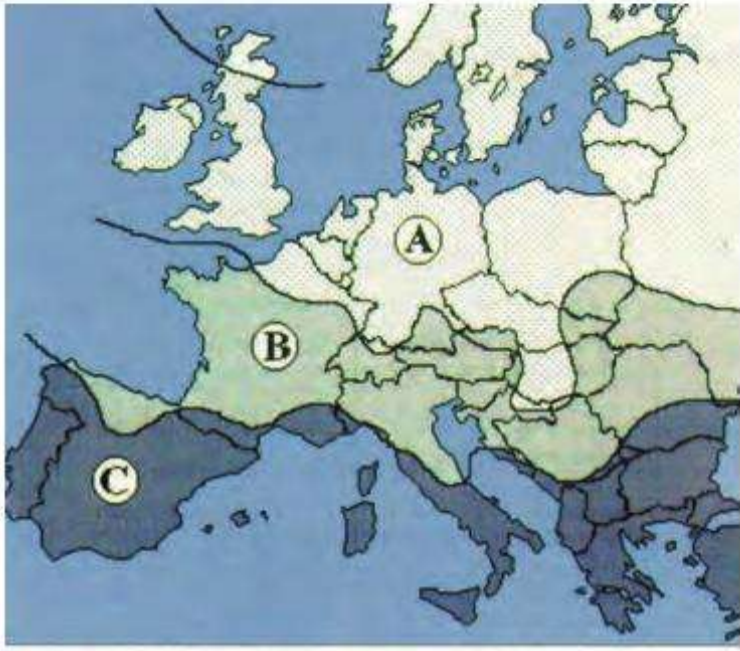

Figure 1.9c.
Miami, USA

Figure 1.10. Total annual global radiation (on horizontal surface)



Zone (see map above)	Average solar radiation on collector surface [kWh/m ² day]	Solar system heat yield [kWh/m ² y]
A	2.4 to 3.4	300 to 450
B	3.4 to 4.4	400 to 550
C	4.4 to 5.4	500 to 650

Figure 1.10a. Europe

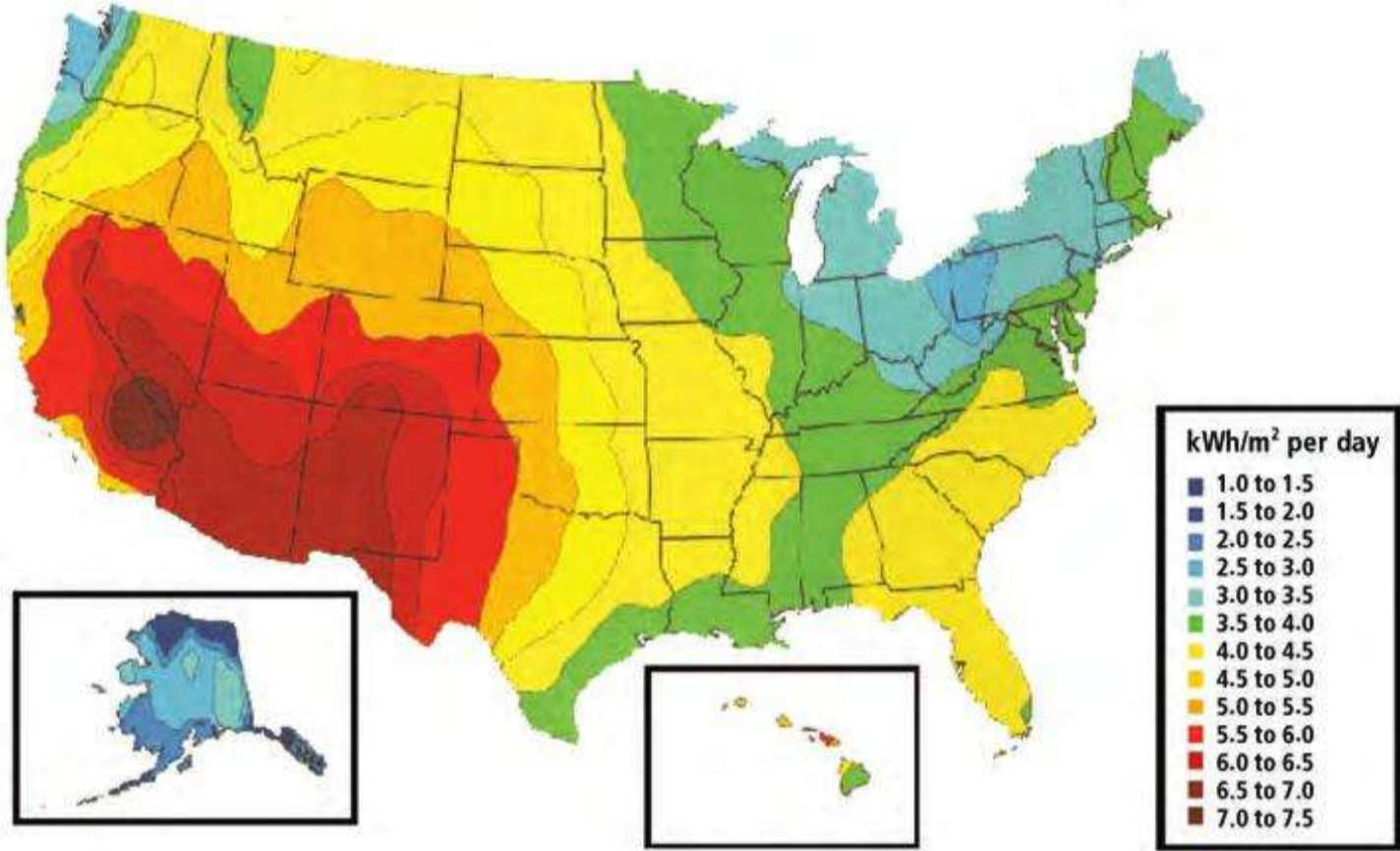

Figure 1.10b. USA

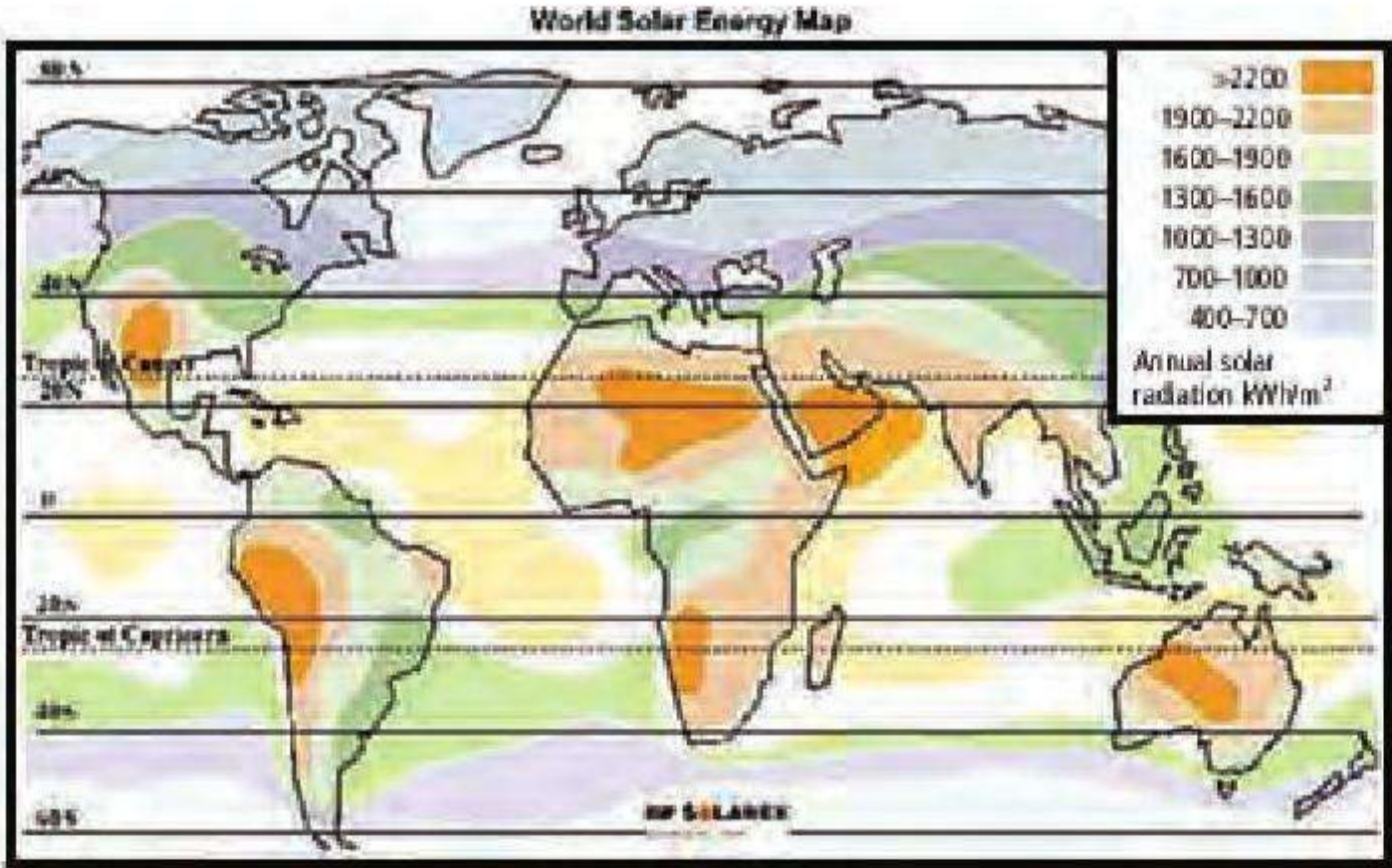

Figure 1.10c. The world

MEASURING SOLAR RADIATION

Devices that measure the global solar irradiance on a horizontal surface are called *pyranometers* (Figure 1.11). If these devices are screened from the sun's direct rays by a fixed ring that covers the whole path of the sun in the sky, then the device measures only the diffused radiation. The radiation receiver is seated beneath a spherical glass cover and consists of a star-shaped arrangement of black and white thermo-elements. These elements generate thermo-electromotive forces, depending on their temperature, which can be measured. Pyranometers are relative measuring instruments that have to be calibrated. Other global solar irradiance measuring devices that are available on the market and are cheaper than pyranometers possess a *solar cell* as a receiver, as in the MacSolar (Figure 1.12), for example.

The simplest and most commonly used device for measuring the sunshine duration is the Campbell–Stokes sunshine recorder (Figure 1.13). This consists of a solid glass sphere, which generates a focal point on the side that is turned away from the sun and which is always at the same distance. A correspondingly curved flameproof paper strip is placed around the sphere. A track is burned on the paper strip. When clouds cover the sun, the burnt track is interrupted.



Figure 1.11.
Pyranometer made by Kipp & Zonen

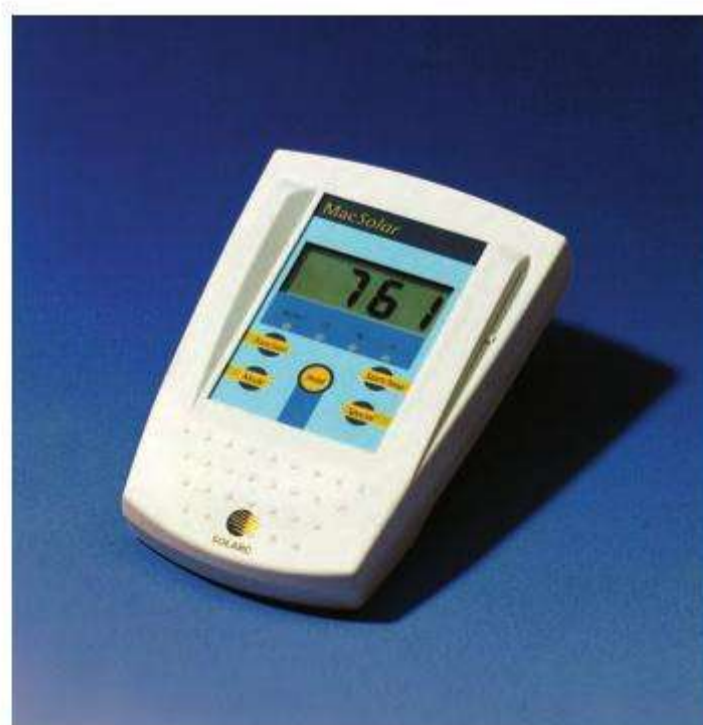

Figure 1.12 (left).
MacSolar

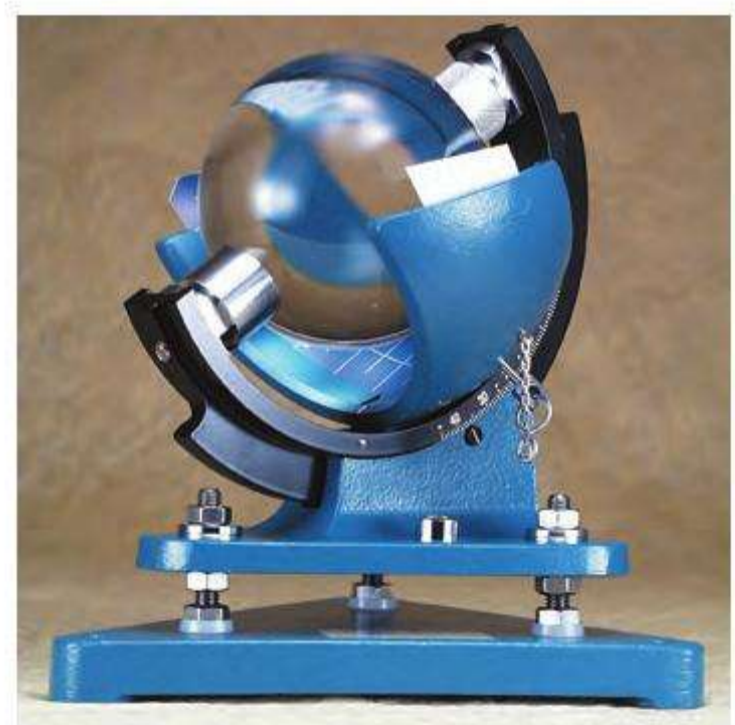

Figure 1.13 (right).
Campbell–Stokes sunshine recorder

1.1.3 Influence of orientation and tilt angle

The variables or figures that have been given so far referred to a horizontal receiving surface, such as a flat roof. Because the angle of incidence of the sun varies over the course of the year, the maximum radiation yield can be obtained only if the receiving surface is inclined at an angle to the horizontal. The optimum angle of inclination is larger in the low-radiation months than in the summer because of the low elevation of the sun.

In solar technology the angle descriptions listed in Table 1.3, and shown in Figure 1.14, are normally used. However, note that sometimes in architecture and building the following values are used as angle descriptions for the solar azimuth: North = 0°, East = 90°, South = 180°, West = 270°.

Table 1.3.
Angle descriptions in solar technology

Sun's height	γ_s	Horizon = 0°	Zenith = 90°	
Solar azimuth	α_s	South = 0°	East = -90°	West = +90°
Surface inclination	β	Horizontal = 0°	Vertical = 90°	
Surface azimuth	α	South = 0°	East = -90°	West = +90°

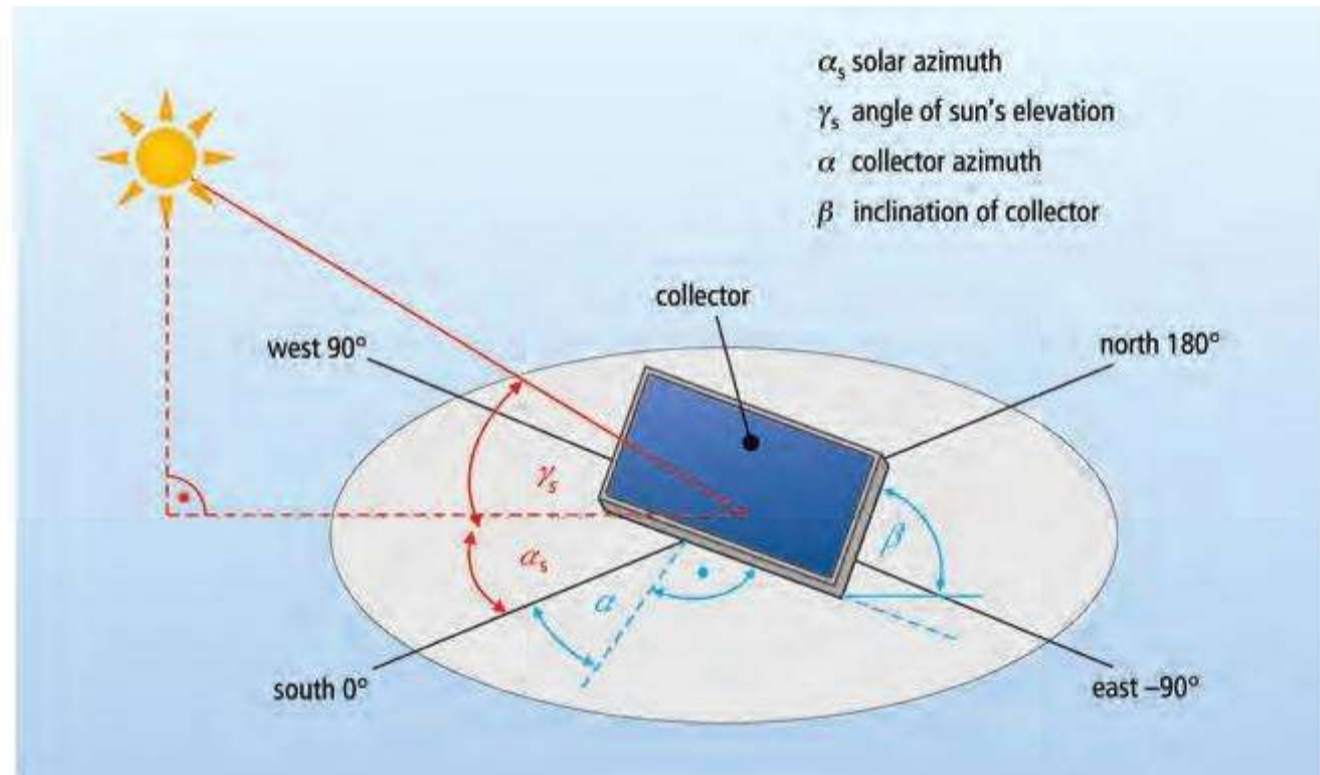

Figure 1.14.
Angle descriptions in solar technology
(northern hemisphere)

What about the influence of roof alignment and inclination on the insolation (incoming solar radiation)? Figure 1.15 shows the values measured in central Europe (Berlin) for the calculated average annual totals of global solar irradiance for differently oriented surfaces. Lines of equal radiation totals are shown in kWh/m² per year. On the horizontal axis the alignment can be read off and on the vertical axis the angle of inclination can be seen.

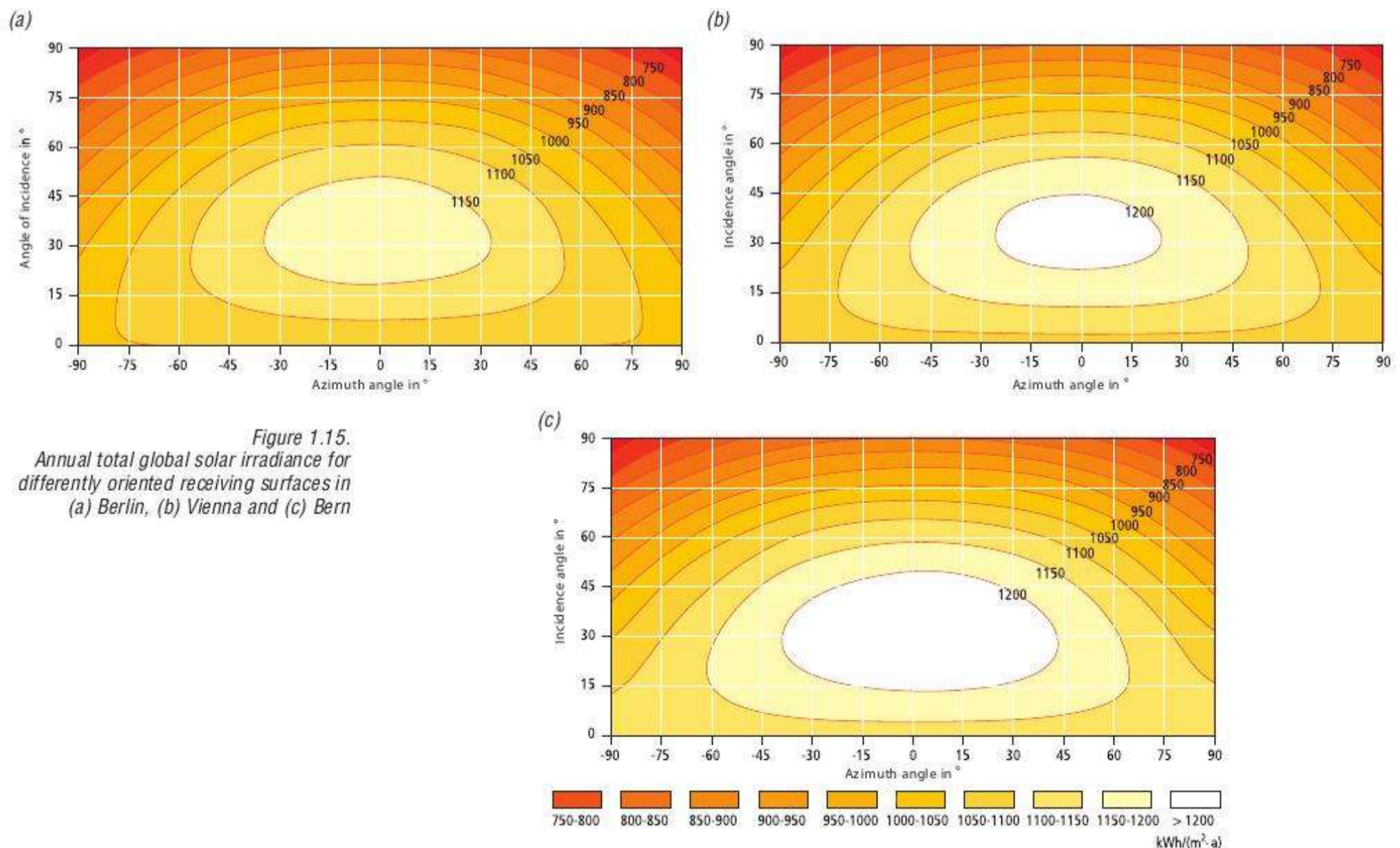

Figure 1.15.
Annual total global solar irradiance for differently oriented receiving surfaces in (a) Berlin, (b) Vienna and (c) Bern

According to the annual average, optimum irradiance occurs with a southern alignment ($\alpha = 0^\circ$) and an inclination of $\beta = 30^\circ$. The graph also shows that a deviation from the optimum alignment can be tolerated over wide ranges, as no significant losses of radiation are involved. Roughly speaking, for central European regions (latitudes of about 50°N) any collector angle between 30° and 60° in combination with an orientation between south-east and south-west will give almost optimal irradiance.

A general, worldwide rule of thumb is that a solar collector should roughly face the Equator and the optimal tilt angle should be close to 0.7 times the latitude, but always at least 10° or the minimum tilt angle specified for the solar collector (many solar collectors require a minimum tilt angle of 15°). For instance, for a latitude of 40°S , the collector tilt angle should be about 30° facing north.

However, deviations from that optimum will in general give only a slight reduction of the irradiation. The optimum angle of inclination for the winter months (October to March) is 50° but, in general, orientations between south-east and south-west and inclination angles between 30° and 60° will lead to a loss of solar radiation of less than 15% compared with the optimum angles.

1.1.4 Collection of dust, and need for cleaning

Whether dust accumulation will take place to such a degree that the solar collector's output would be significantly reduced is entirely dependent on the climate. In central Europe there is enough rain to keep the collector clean. Measurements show that, in these climates, the performance reduction due to dust on the collectors will be limited to 2% or less. However, in tropical and dusty climates this can be very different, and regular cleaning (once per month or more frequently) is needed to maintain the collector's output. Some solar water heating systems in tropical countries are even equipped with a sprinkling system to make regular cleaning easier.

SHADING

Shading reduces the yield of a solar thermal system. To take account of shading of the receiving surface by the surroundings (houses, trees etc.), three methods can be used:

- graphical method (indicative)
- photographic method (indicative)
- computer-aided method.

GRAPHICAL METHOD

This method requires a scale drawing of the layout of the surroundings, details of the height of each object that could shade the potential collector position, and a *solar altitude diagram* for the latitude at which the collector is to be located. First, the elevation and azimuth angles of the relevant objects must be established, and then the shade silhouette must be plotted in the solar altitude diagram. If large areas of shade arise in time periods with high radiation, then the expected radiation received must be reduced correspondingly.

PHOTOGRAPHIC METHOD

In this method a camera with a 'fish-eye' lens is used in connection with special solar-geometrical accessories to photograph the surrounding silhouette while blending in the solar altitude diagram of the respective location. The results can then be read directly off the photograph.

COMPUTER-AIDED METHOD

Several simulation programs are provided with shade simulators (see for instance TRNSYS and SUNDI in Chapter 10). After determining the elevation and azimuth angles of important objects, the influence of shade can be directly calculated within the scope of the system simulation. This method yields more accurate results than the previous two methods.

Figure 1.16 shows an example of a solar altitude diagram with surrounding silhouette.

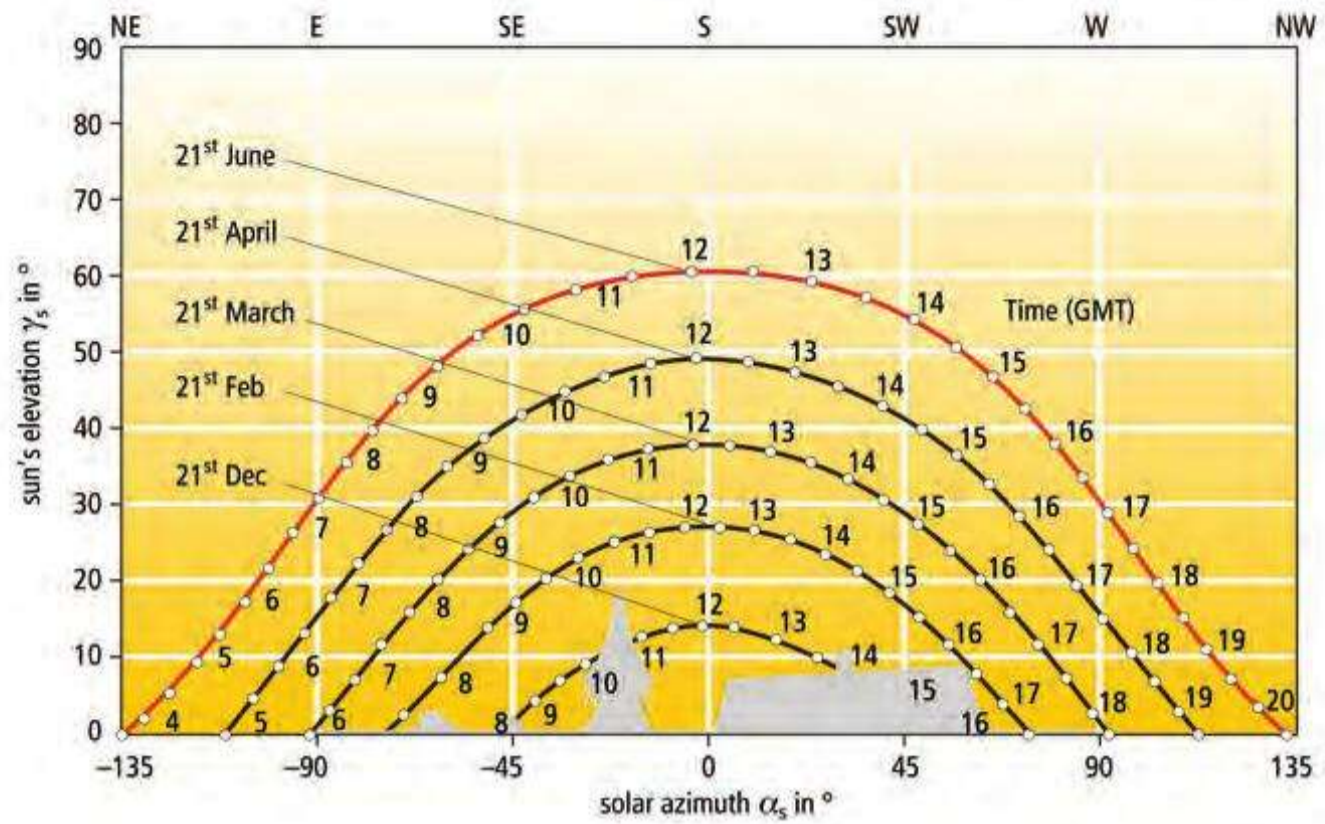

Figure 1.16. Solar altitude diagram with example silhouettes of objects (for latitude of about 50°)

1.2 The finiteness of energy resources

The available resources of fossil fuels (coal, oil, natural gas and uranium) are being consumed at an ever-increasing rate to meet the growing energy requirement on our planet. Because stocks are finite, this process will inevitably lead us into a cul-de-sac. The key that leads us out of this dilemma is to save energy, to use energy rationally, and to use renewable energy sources: sun, wind, water and biomass.

Figure 1.17 emphasizes the relationship between fossil fuel reserves, energy requirement and the radiation supplied by the sun.

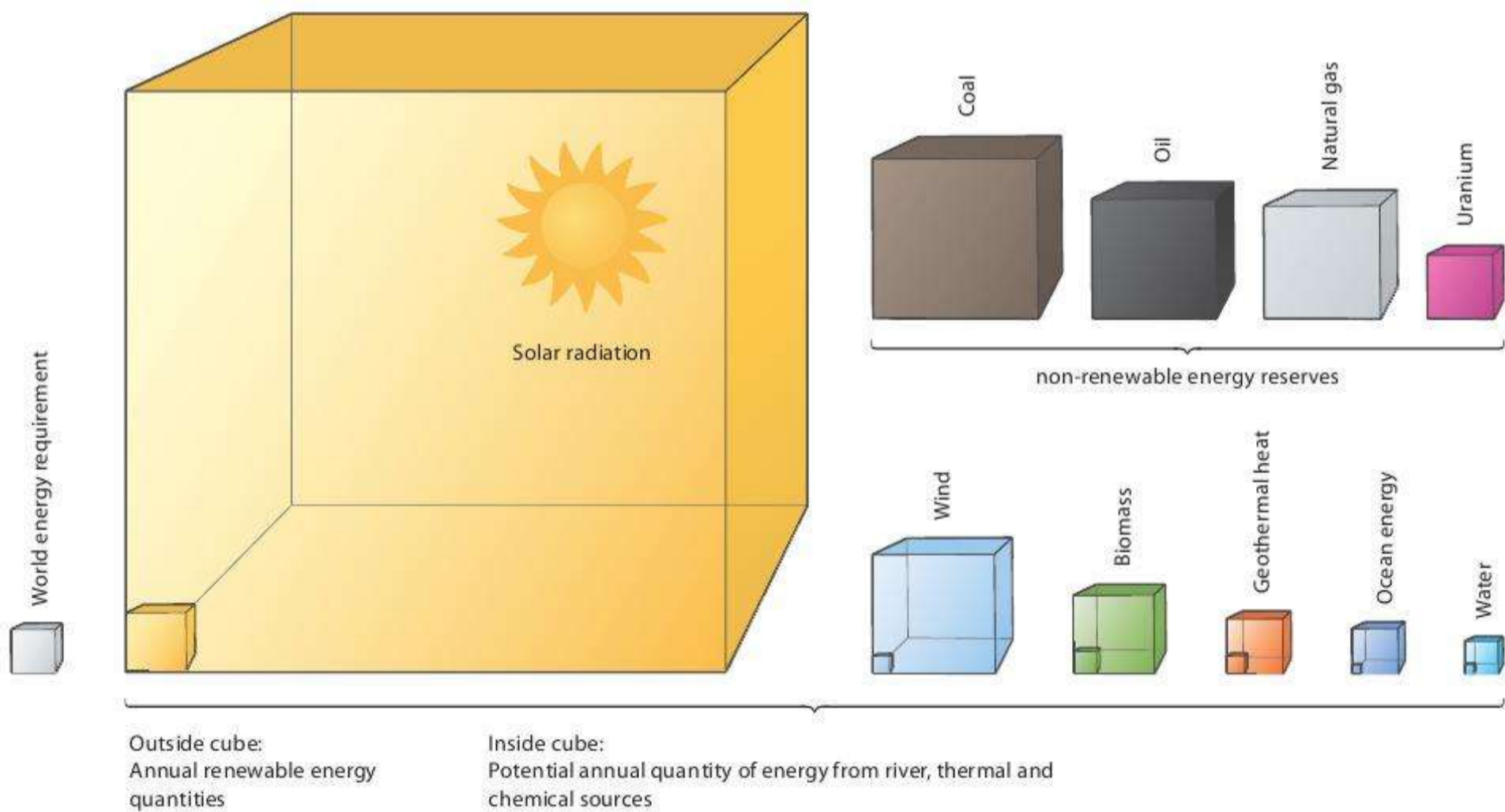

Figure 1.17. The energy cube

Each year the sun provides a multiple of the world energy consumption, and indeed even a multiple of all the known fossil fuel reserves. Put into numbers, it is 1.5×10^{18} kWh/a, or 1500 million billion kilowatt-hours per annum. This is more than 10,000 times the energy that the human race needs at present. Moreover, the radiation supply from the sun carries a 5 billion-year guarantee.

THE FORECAST LIFETIME OF OIL AND NATURAL GAS RESERVES

OIL

The current estimate of secured oil reserves is between 118 and 180 billion tonnes: the latter figure includes so-called *non-conventional* oil reserves (heavy oils, tar sand, oil shale, and oil deposits in deep waters and polar regions). From this it is evident that even with the same oil extraction rate as in 1995 of 3.32 billion tonnes per year the oil reserves will be exhausted by about 2050 (Figure 1.18). However, it is more realistic to assume that increased energy consumption will result in a faster rate of use of the reserves.

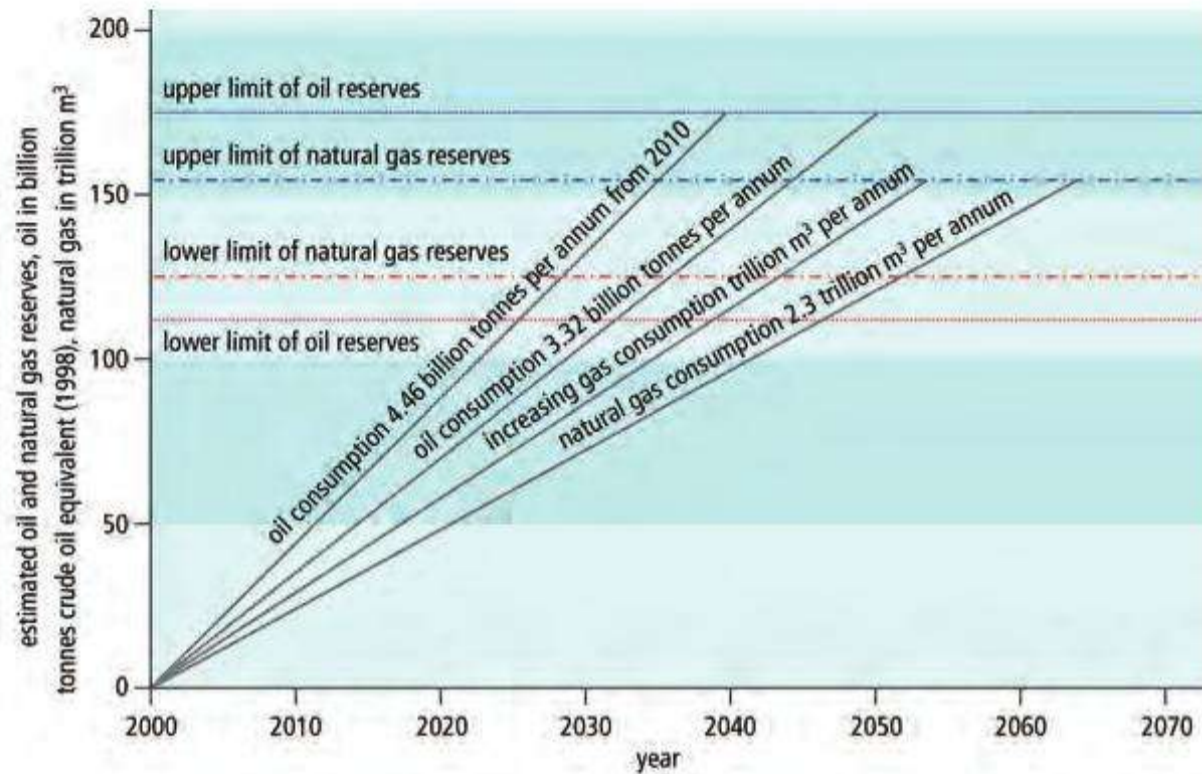

Figure 1.18. Reserves and forecast lifetime of oil and natural gas⁴

NATURAL GAS

The figures for natural gas reserves vary from 131 to 153 trillion m³ (4626 to 5403 trillion ft²). With a steady annual extraction rate of 2.3 trillion m³ (81.22 trillion ft²) (as in 1995) the reserves would be exhausted after 57–65 years. But it is exactly in this area of gas consumption that the greatest annual rate of increase is found, so that the reserves will very probably run out well before the year 2040.

Even more decisive for structural changes in the energy supply is the question of the point in time when for geological, technical and economic reasons oil and gas production can no longer be increased, but will tend only to reduce. The maximum worldwide extraction rate (the big rollover) is expected to be reached during the second decade of the 21st century: that is, between 2010 and 2020 (Figure 1.19). From then on we can expect to see significant price increases.³

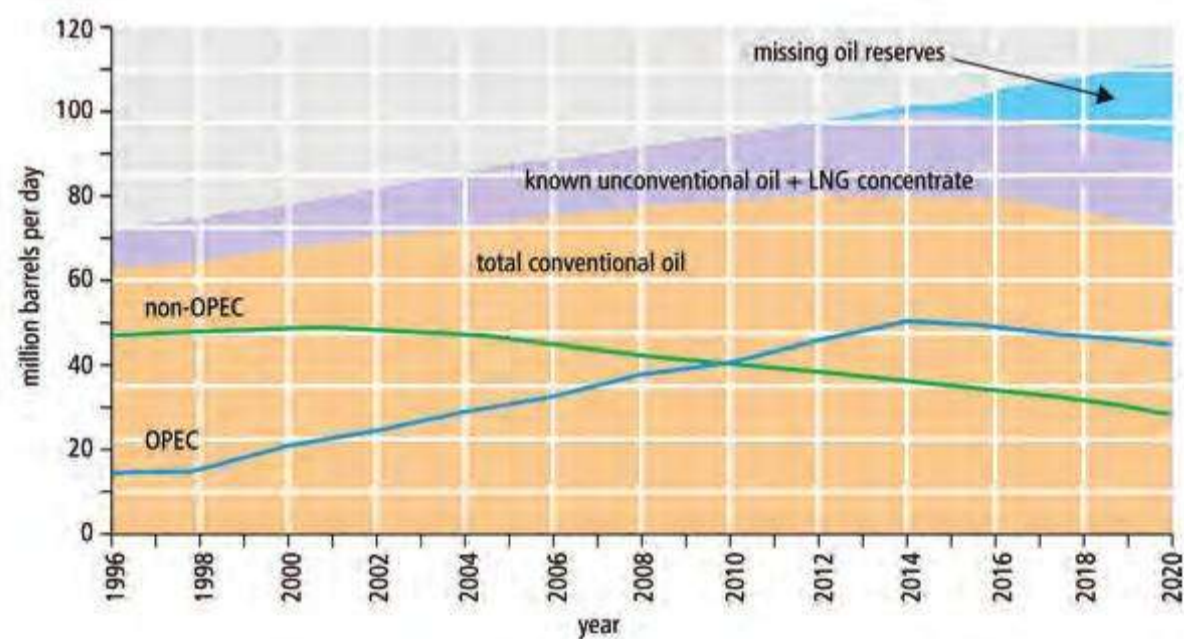

Figure 1.19. The OPEC proportion constantly increases from 27% today to over 60% in the year 2020. In 2020 an under-supply of liquid hydrocarbons of about 17% – or a quarter of today’s world oil production – is expected.⁵

Based on experience, we know that in the area of technical innovations the changeover period will last for several decades. This means that immediate action is required. Thermal solar technology uses the unlimited supply offered by the sun and makes it possible for every solar plant operator to make an active contribution to mitigating the increasing dangers connected with the shortage of resources.

1.3 Climate change and its consequences

Based on the apparent finite energy resources, the environment and the climate are being dramatically changed and damaged to an ever-greater extent by the burning of fossil fuels. The cause of this is the emission of hazardous substances such as sulphur dioxide, oxides of nitrogen and carbon dioxide connected with the incineration process.

- Sulphur dioxide and oxides of nitrogen are among those hazardous substances that play a significant part in causing acid rain.
- Carbon dioxide (CO₂) is the greenhouse gas that is mainly responsible for the heating up of the earth's atmosphere. For many thousands of years the CO₂ concentration remained nearly constant. Over the past 200 years the CO₂ concentration has increased from approximately 270 ppm* to currently 385 ppm at an ever-increasing rate.

Other greenhouse gases we emit include:

- Methane (CH₄) from agriculture
- Nitrous oxide (N₂O).

GREENHOUSE EFFECT

The earth-atmosphere system absorbs the visible, shortwave radiation from the sun in the wavelength range of approximately 0.3–3.0 μm. The result of this is heating up of the earth's surface and the atmospheric layers. In turn, each heated body radiates according to its temperature. However, this heat emission takes place in a longer wavelength range of between 3.0 and 30 μm.

NATURAL GREENHOUSE EFFECT

CO₂ molecules can retain part of this heat energy radiated back from the earth's surface and the atmosphere. This process is called the *greenhouse effect*, as the CO₂ layer in the atmosphere can be compared with the glass planes in a greenhouse, which let the light in but keep the heat from getting out. With the natural content of CO₂ in the earth's atmosphere the temperature of the earth is currently +15°C (59°F) on average. Without this natural content temperatures would be around –15°C (5°F) and human life on earth would be impossible.

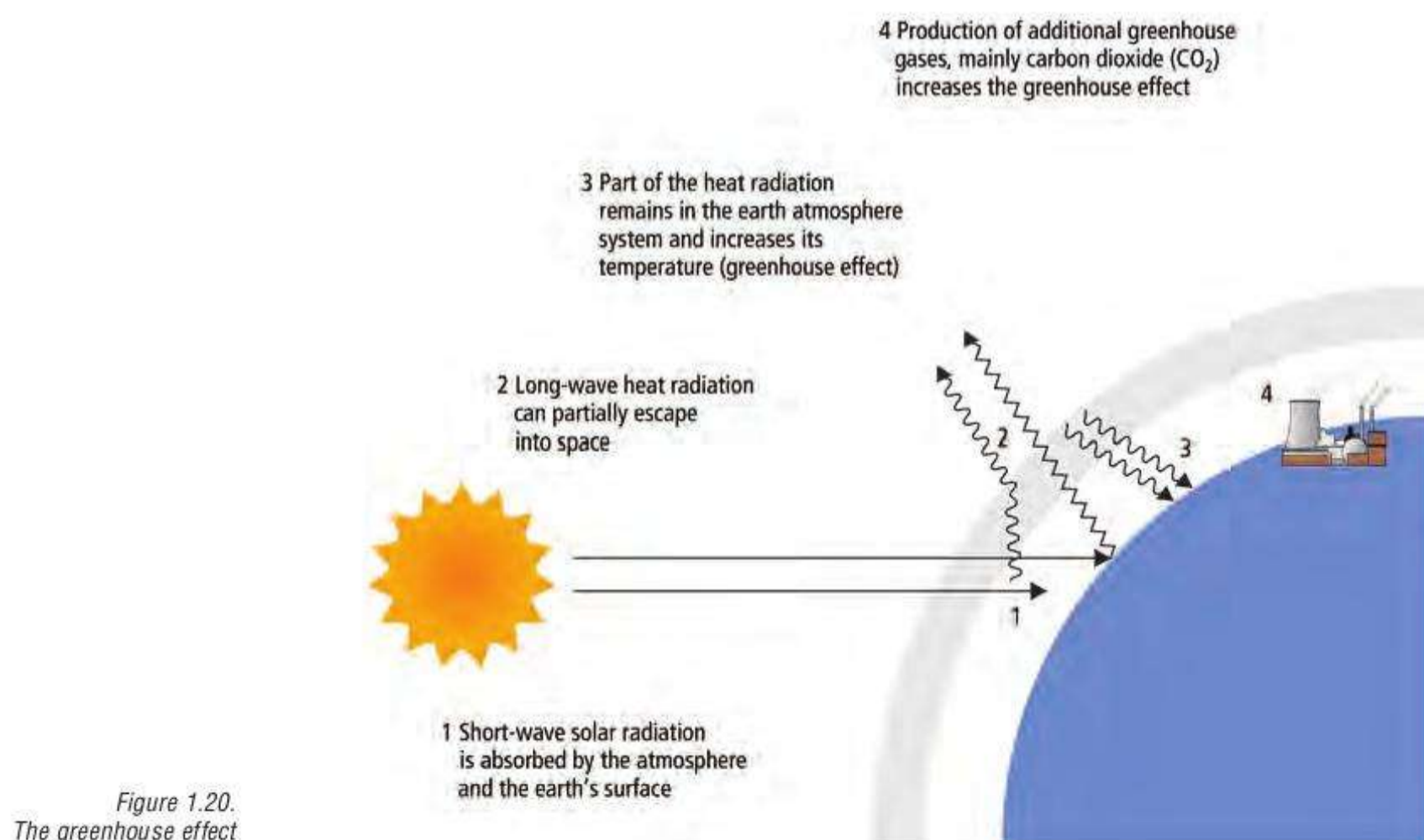

Figure 1.20.
The greenhouse effect

* ppm (parts per million) in this context means that every millionth air particle is a carbon dioxide molecule.

MAN MADE GREENHOUSE EFFECT

Through the incineration process of coal, oil and natural gas the amount of CO₂ released by mankind from the 19th century onwards has become so great that nature can no longer compensate for this increase. The consequence is an additional greenhouse effect that causes the earth's temperatures to increase continuously ('global warming').

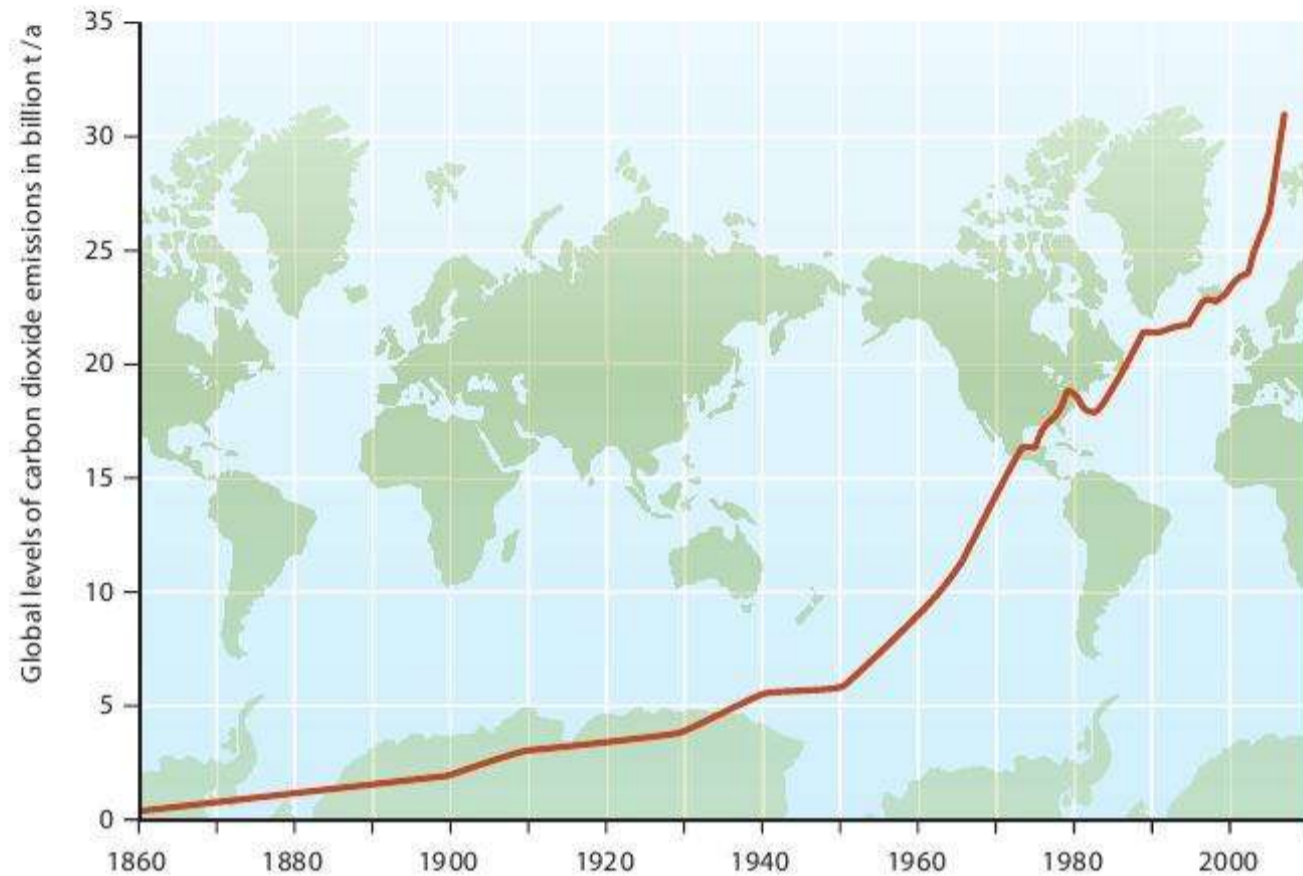

Figure 1.21.
Global CO₂ emissions

Consequences of climate change

Most scientists now agree on the potentially catastrophic effects of an increase in the annual average global temperature:

- Heating of oceans, and melting of the glaciers, leading to an increase in the sea level, with the result that some coastal regions have been flooded and building land has been lost (more than one third of the world's population live in coastal regions).
- Displacement of the vegetation zones, resulting in drastic changes in food production, and a dramatic reduction in the variety of species.
- The release of huge amounts of CO₂ and methane from the thawing ground of the tundra, which further increases the overall effect.
- The 'Mediterraneanization' of the temperate latitudes, with hot, dry summers and milder but wet winters, resulting in shortages of water in summer, floods in winter, and a high load on already severely damaged forests.
- An increase of weather-related damage caused by storms, floods and droughts, with growing economic cost.
- Intensification of known climate phenomena, such as El Niño, with an increase in the frequency of torrential storms in the otherwise dry areas of South America).

Added to this is environmental damage caused by the extraction and transportation of fossil fuels. In particular, oil spills result in severe ecological devastation. Between 1967 and 2002, 22 oil spills (oil leakage > 10.000 t) were counted, which in total released 2.4 million tonnes of oil into the ocean (Greenpeace, 2002).

In 2006, Professor Nicholas Stern released a review commissioned by the British Government with the title 'The Economics of Climate Change' (see also Figure 1.22) .

Results:

- Annual costs of stabilizing climate warming at around 2 Kelvin above pre-industrial levels, equivalent to 450 ppm CO₂, are 1% of the annual GDP.
- Costs of no climate protection are 5 to 20 times higher owing to climate related damages.

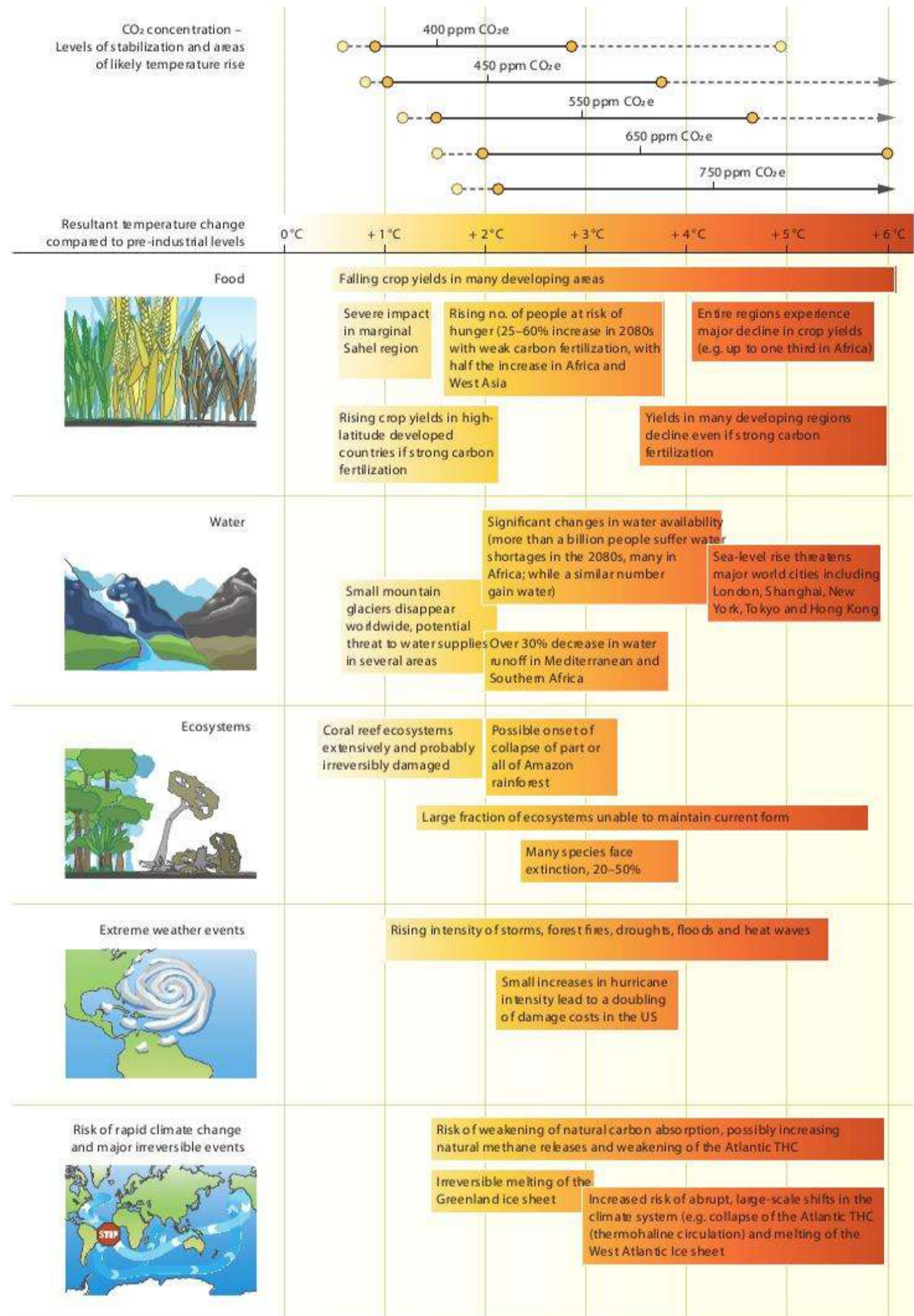

Figure 1.22. Stern, *The Economics of Climate Change*, 2006

Because experience has shown that technical improvements require many decades, immediate action is needed. Ways to escape from this dilemma are:

Reduction of non-renewable energy sources, through

- The lowering of the heat demand in buildings through improved heat insulation
- The lowering of energy construction losses through more efficient construction procedures
- The substitution of non-renewable for renewable energy sources

And last but not least

- Changes in consumer behaviour.

1.4 Good arguments for solar systems

Every year the number of freshly installed collector surfaces increases, with an annually increasing rate of growth (the collector surface installed in 2003 in Europe was around 1,450,000 m² (4,843,760 ft²)). The European market has grown on average by 18% per year in the period 1994 to 1999.⁷

Every new square metre of installed solar collector surface increases the trend and is an active contribution to the protection of the climate:

- Solar system owners do not wait for political decisions or global changes, but simply act.
- The solar system is an easily visible sign of a high level of responsibility, environmental awareness and commitment.
- Solar system owners are pleased with every ray of the sun, and experience their environment with more awareness.
- They enjoy bathing, showering or washing their clothes using water heated by the sun – particularly in the summer, when the heating boiler can remain switched off.
- The solar system makes them less dependent on increases in energy prices.
- Solar system operators enjoy tax advantages and government funding in many countries (see Chapter 11).
- Solar systems increase both the value of the property and its image. ‘Solar houses’ can be sold or rented out more easily.
- Thermal solar systems for the provision of hot water are technically mature and have a service life of about 20 years.
- A standard solar system covers between 50% (in northern latitudes) and 90% (in subtropical and tropical climates) of the yearly energy required for the provision of hot water. Even in northern latitudes, 90% of the energy demand between May and September can be covered.
- Solar systems for swimming pool water heating are economical to install, and their cost can be amortized over a very short period of time.
- Within the course of its life a solar system supplies about 13 times more energy than was used to make it.
- Solar systems require very little maintenance, and their energy is permanently available.
- By taking up solar technology the trade gains new areas of work, which are secure for the future.
- Solar technology creates lasting employment in production, installation and servicing.

2 Components of solar thermal systems

2.1 How does a solar thermal system work?

The solar collector mounted on the roof converts the light that penetrates its glass panes (short-wave radiation) into heat. The collector is therefore the link between the sun and the hot water user. The heat is created by the absorption of the sun's rays through a dark-coated, usually metal, plate – the *absorber*. This is the most important part of the collector. In the absorber is a system of pipes filled with a *heat transfer medium* (usually water or an antifreeze mixture). This takes up the generated heat. Collected together into a pipe it flows to the *hot water store*. In most solar water heating systems – by far the most commonly used type of solar thermal systems – the heat is then transferred to the domestic water by means of a *heat exchanger*. The cooled medium then flows via a second pipeline back to the collector while the heated domestic water rises upwards in the store. According to its density and temperature, a *stratified system* is set up in the store: the warmest water is at the top (from where it leaves the tank when the taps are turned on) and the coldest is at the bottom (where cold water is fed in).

In central and northern Europe, as well as in the USA, Canada and other countries, thermal solar systems operate with a water–glycol mixture that is circulated in a closed circuit (forced circulation). This system, which has a solar circuit separated from the domestic water circuit, is called an *indirect system* (see Figure 2.1). In some countries systems also exist with pure water as the heat transfer medium (for instance the so-called *drainback systems*) or with direct circulation of the domestic water through the collector.

The controller will only start the solar circuit pump when the temperature in the collector is a few degrees above the temperature in the lower area of the store. In this way the heat transfer liquid in the collector – having been warmed by the sun – is

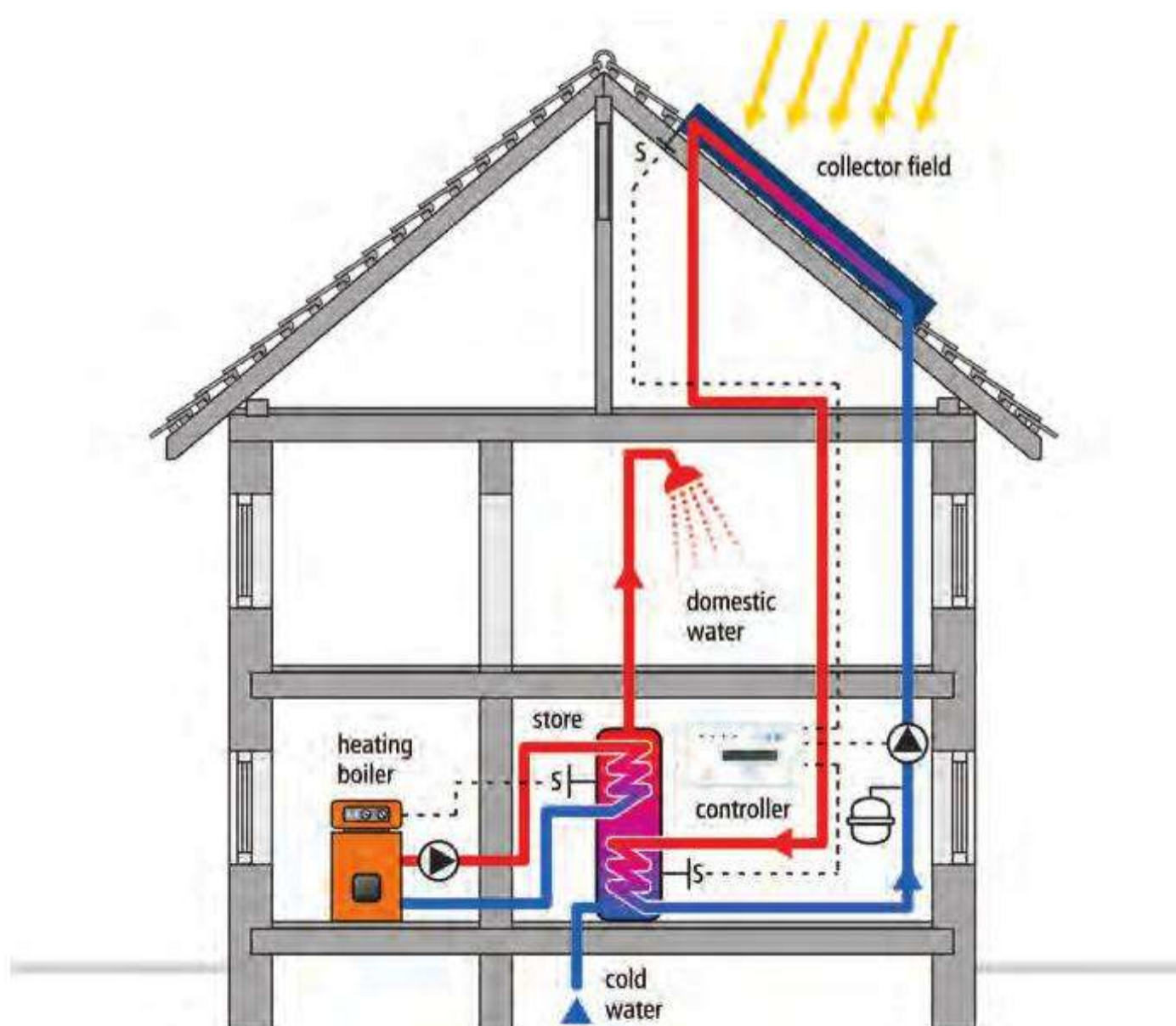

Figure 2.1.
Standard solar water heating system
with heating boiler for additional heating
(S = temperature sensor)

transferred into the lower heat exchanger, where the heat is transferred to the stored domestic water.

In Australia, Israel and other Mediterranean countries, as well as many other countries, especially with tropical or subtropical climates, systems are designed based on the principle that hot water rises. These are called *thermosyphon* systems, and the storage tank is almost always located outdoors, directly on top of the solar collector; see Figure 2.2.



Figure 2.2.
Standard thermosyphon solar water
heater with outdoor tank
Source: Solahart

For temperate climates, in a solar system for one- and two-family homes with dimensions of about 0.6–1.0 m² (6.46–10.76 ft²) of collector surface per person and approximately 40–60 l (10.6–15.9 gallons) of storage volume per person, the water is mostly heated by the solar system in the summer. This provides an annual degree of coverage (proportion of solar energy to the total energy required for domestic water heating) of about 50–60%. The remaining 40–50% has to be covered by auxiliary heating. For pumped systems, this is often done by means of an extra heat exchanger in the top of the store. Other common solutions are to use the solar water heater as a preheater and connect the solar-heated water to a conventional boiler, or (mainly for sunny climates) to use an electrical element immersed in the store.

Another decisive factor in establishing the level of supplementary energy required is the target domestic water temperature on the boiler controller. The lower this is set, for example 45°C (113°F), the higher the coverage proportion of solar energy and correspondingly the lower the proportion of auxiliary energy, and vice versa. However, in some countries, domestic hot water regulations pose a lower limit on this temperature setting, of 60°C (140°F).

The individual components of thermal solar systems are introduced in the following sections.

2.2 Collectors

Collectors have the task of converting light as completely as possible into heat, and then of transferring this heat with low losses to the downstream system. There are many different types and designs for different applications, all with different costs and performances. See Figures 2.3 and 2.4.

Different definitions of area are used in the manufacturers' literature to describe the geometry of the collectors, and it is important not to confuse them:

- The *gross surface area* (collector area) is the product of the outside dimensions, and defines for example the minimum amount of roof area that is required for mounting.
- The *aperture area* corresponds to the light entry area of the collector – that is, the area through which the solar radiation passes to the collector itself.

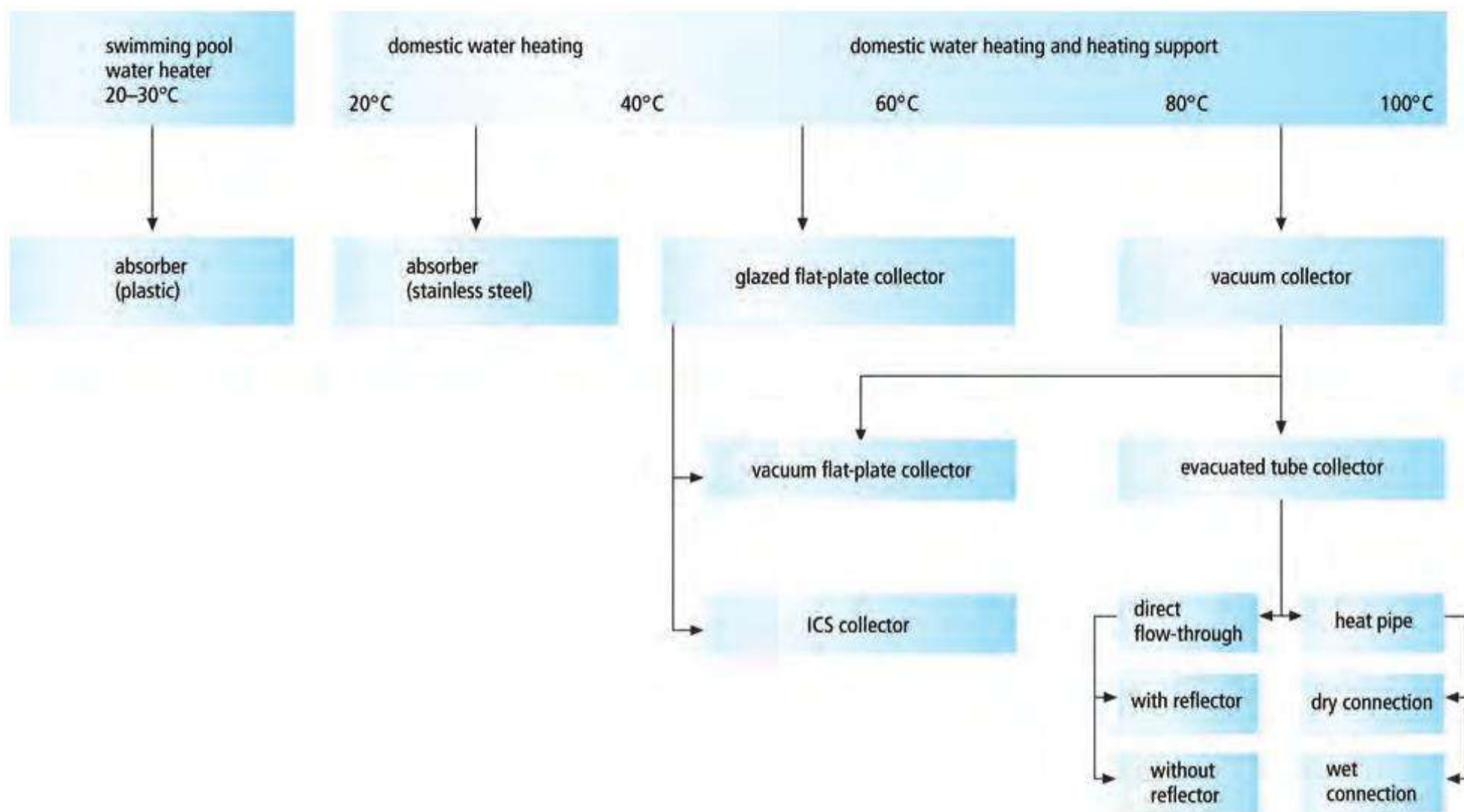

Figure 2.3. Overview of types of collector

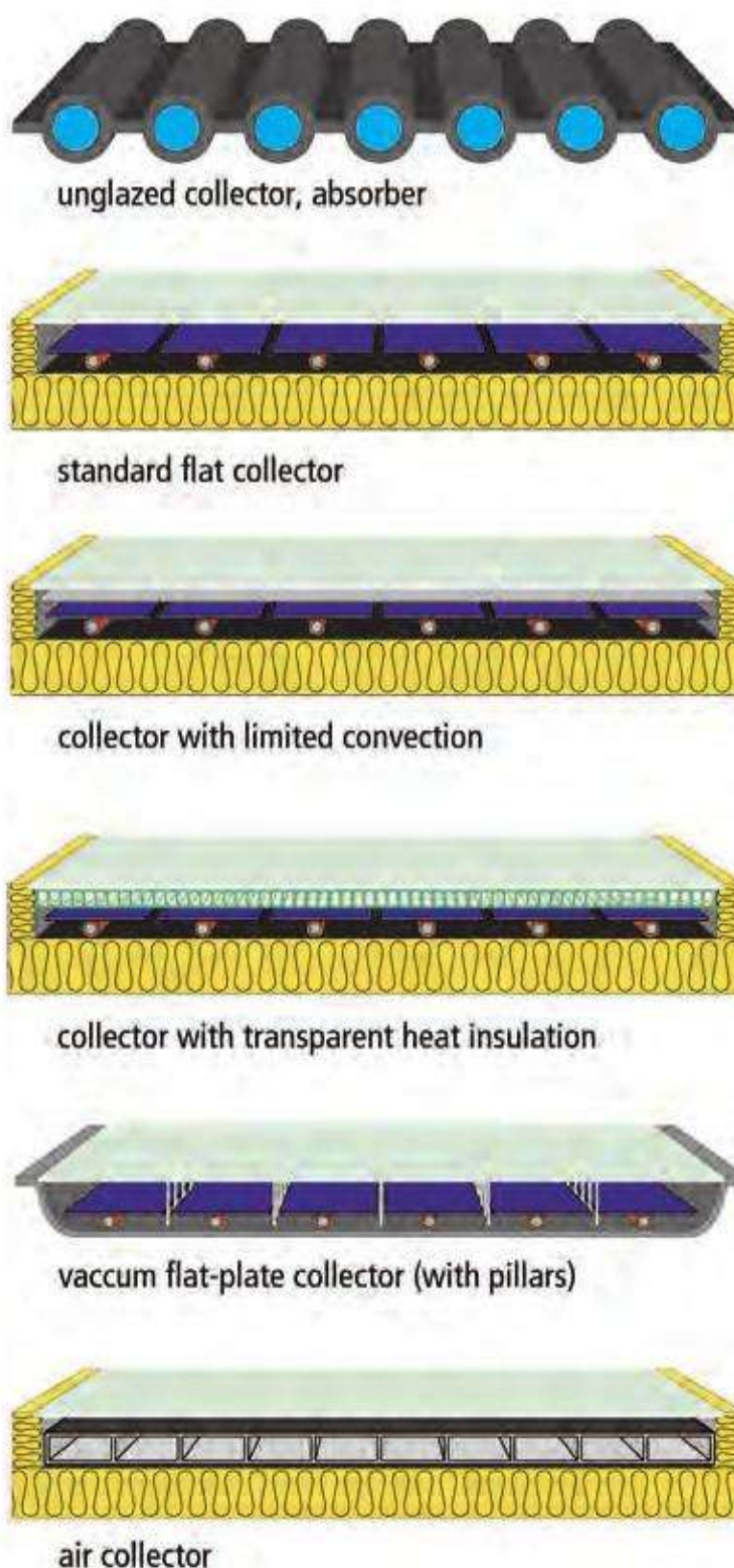

Figure 2.4. Different collector designs

- The *absorber area* (also called the *effective collector area*) corresponds to the area of the actual absorber panel. See Figures 2.5–2.7.

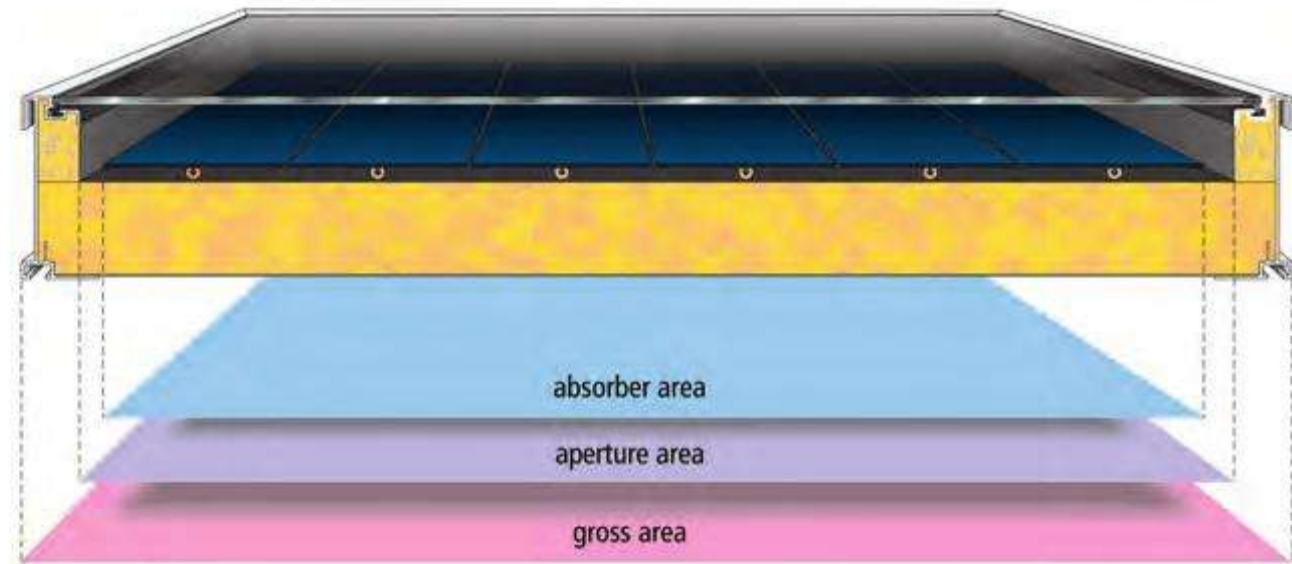

Figure 2.5.
Cross-section of a flat-plate collector
with description of the different areas

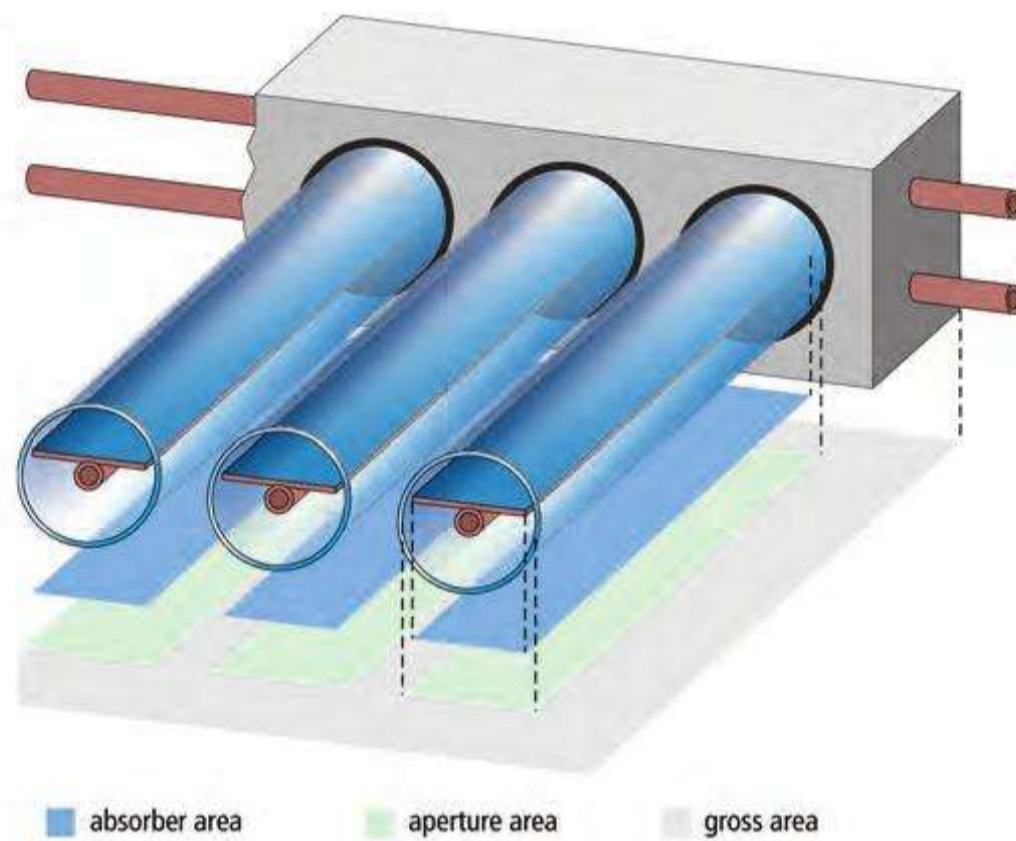

Figure 2.6.
Cross-section of a heat-pipe evacuated
tube collector with description of the
different surface areas

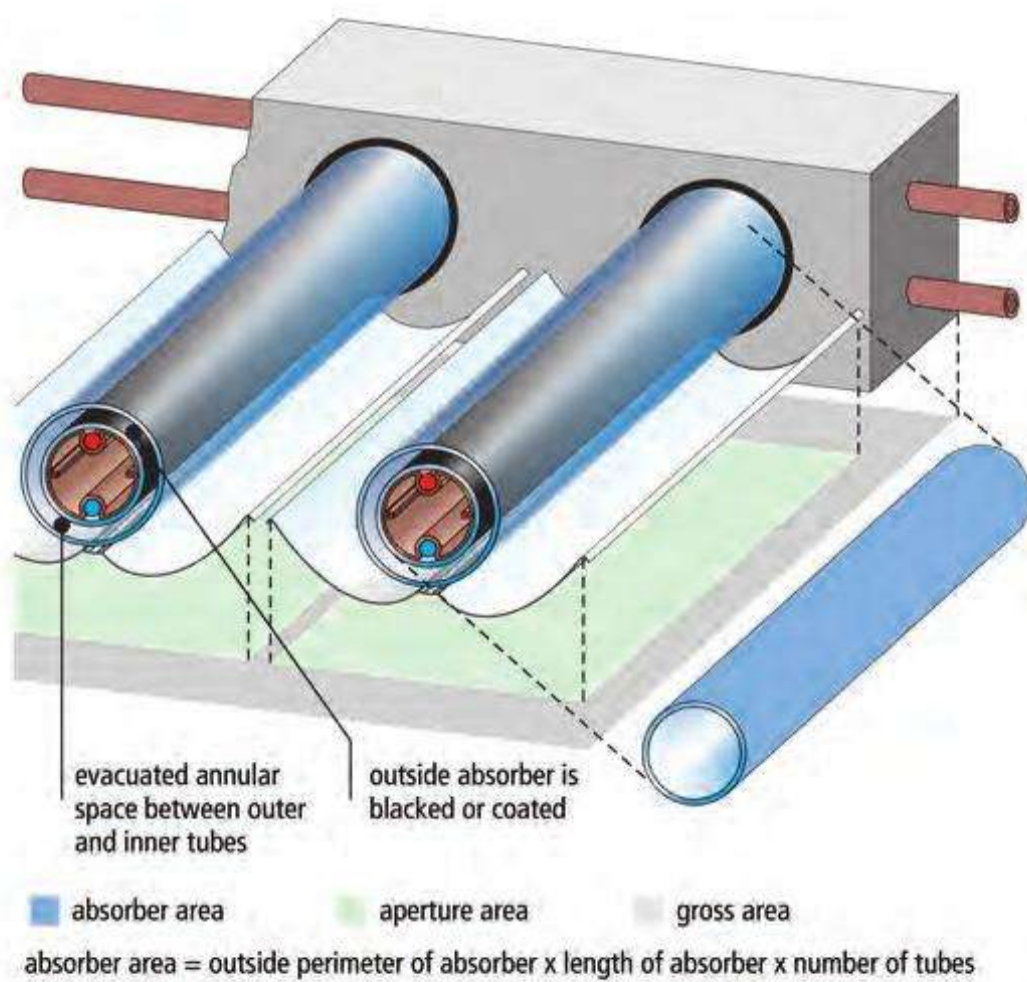

Figure 2.7.
Cross-section of a double evacuated tube
collector ('Sydney tubes') with
description of the different surface areas

absorber area = outside perimeter of absorber x length of absorber x number of tubes

When comparing collectors, the *reference area* is important – that is, the surface area from which the collector's characteristic values are drawn. In the collector test methods, according to EN 12975, the reference area is equal to either the aperture area or the absorber area.

For the energy yield, it is not the collector (gross) area that is crucial but the absorber area. (The exception to this is evacuated tube collectors with reflectors (see section 2.2.3). In this case the receiving area – that is, the aperture area – is crucial. The radiation that impinges on this area is reflected to the absorber.)

2.2.1 Unglazed collectors

The simplest kind of solar collectors are unglazed collectors. These have no glazing or insulated collector box, so that they consist only of an absorber (see also section 2.2.2). Unglazed collectors can be found in various application areas, but they are used mainly as a plastic absorber for heating swimming pool water (see Chapter 7). They are also sometimes found as a selectively coated stainless steel absorber for preheating domestic water. This collector has a lower performance at equal operating temperatures than a glazed flat-plate collector as it lacks the glass cover, housing and thermal insulation. It therefore has higher thermal losses and can be used only at very low operating temperatures, but because of its simple construction it is inexpensive. See Table 2.1.

Table 2.1.
Comparison of yields and cost for
stainless steel absorber and flat-plate
collector^a

	Yield (kWh/m ²)	Cost (€ or US\$ per m ²)	Cost (£ per m ²)
Unglazed stainless steel absorber	250–300	140–160	98–112
Flat-plate collector	350–500	200–350	140–245

^aNot including fixing, mounting and VAT

Advantages of the unglazed collector:

- The absorber can replace the roof skin, saving a zinc sheeting, for example. This leads to better heat prices through reduced costs.
- It is suitable for a diversity of roof forms, including flat roofs, pitched roofs and vaulted roofs. It can easily be adapted to slight curves.
- It can be a more aesthetic solution for sheet metal roofs than glazed collectors.

Disadvantages:

- Because of the lower specific performance, it requires more surface area than a flat collector.
- Because of the higher heat losses, the temperature increase (above the air temperature) is limited.

2.2.2 Glazed flat-plate collectors

2.2.2.1 DESIGN

Almost all glazed flat-plate collectors currently available on the market consist of a metal absorber in a flat rectangular housing. The collector is thermally insulated on its back and edges, and is provided with a transparent cover on the upper surface. Two pipe connections for the supply and return of the heat transfer medium are fitted, usually to the side of the collector. See Figure 2.8.

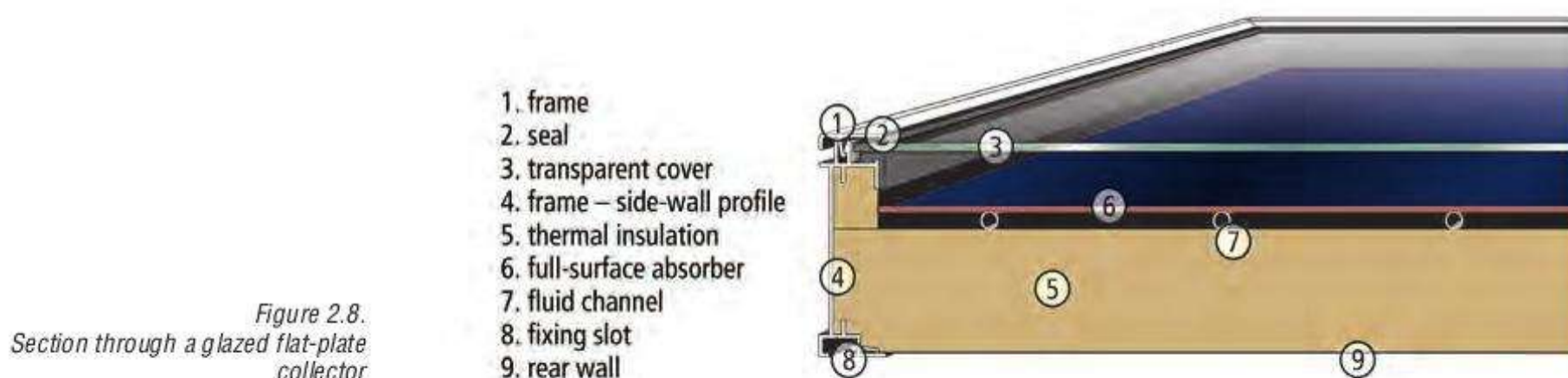

Without the glass cover, glazed flat-plate collectors weigh between 8 and 12 kg per m² (1.6 and 2.5 lb per ft²) of collector area; the glass cover weighs between 15 and 20 kg/m² (3.1 and 4.1 lb per ft²). These collectors are made in various sizes from 1 m² (10.76 ft²) to 12.5 m² (134.55 ft²), or larger in some cases.

ABSORBER

The core piece of a glazed flat-plate collector is the *absorber*. This consists of a heat-conducting metal sheet (made of copper or aluminium for example, as a single surface or in strips) with a dark coating. The tubes for the heat transfer medium, which are usually made of copper, are connected conductively to the absorber. When the solar radiation hits the absorber it is mainly absorbed and partially reflected. Heat is created through the absorption and conducted in the metal sheet to the heat transfer medium tubes or channels. Through these tubes flows the liquid heat transfer medium, which absorbs the heat and transports it to the store. A variant is the so-called *cushion absorber*, which has full-surface flow-through.

The task of a solar collector is to achieve the highest possible thermal yield. The absorber is therefore provided with a high light-absorption capacity and the lowest possible thermal emissivity. This is achieved by using a *spectral-selective coating*. Unlike black paint, this has a layered structure, which optimizes the conversion of short-wave solar radiation into heat while keeping the thermal radiation as low as possible. See Figure 2.9.

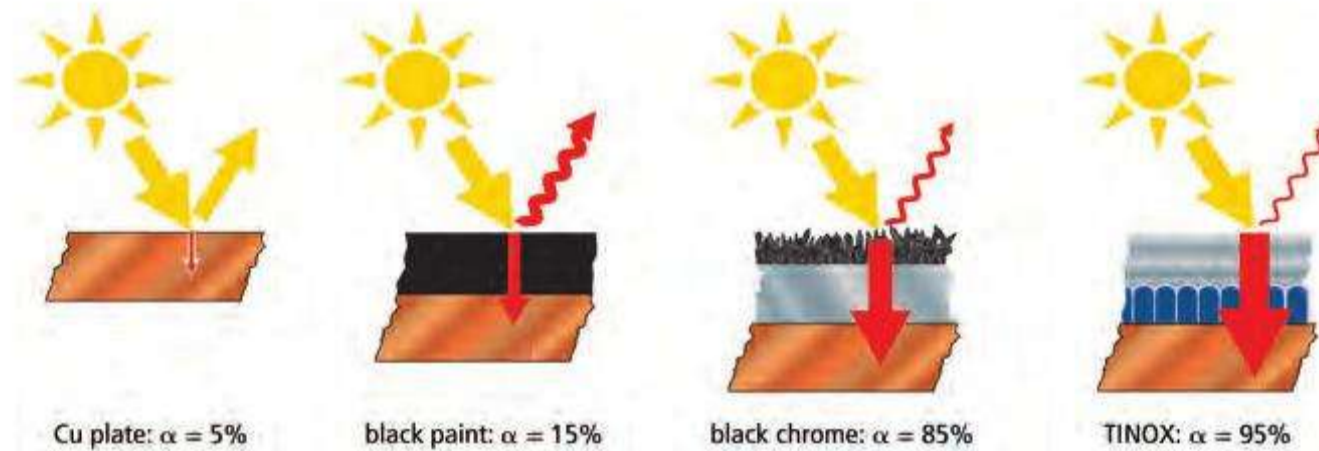

Figure 2.9. Absorption and emission behaviour of different surfaces

Most spectral-selective layers have an absorption rate of 90–95%, and an emission rate of 5–15%. Commonly used selective coatings consist of black chrome or black nickel. See Table 2.2. However, the latest developments in selective coatings with improved optical characteristics currently offered on the market have been applied either in a vacuum process or by sputtering. These processes feature a significantly lower energy consumption and lower environmental load during manufacturing in comparison with black-nickel and black-chrome coatings, which are usually applied by electroplating. In addition, the energy gain of these absorbers is higher at higher temperatures, or at low levels of solar irradiance, than that of absorbers with black-chrome or black-nickel coatings.⁸

Table 2.2. Advantages and disadvantages of various absorber types

Type	Advantage	Disadvantage
Roll-bonded absorber	Good thermal properties, no mixed materials; simplifies subsequent recycling	Subject to corrosion of aluminium in connection with copper tube
Absorber strips with pressed-in copper tube	High flexibility in size; cheap because of greater volume of production	Many solder points
Absorber with tube system pressed in between metal sheets	No mixed materials; simplifies subsequent recycling	High production cost as connection possible only on plain metal sheet
Absorber with soldered-on tube system	Very flexible in size and flow rate	Heat transfer not optimal
Full flow-through stainless steel absorber	Good heat transfer to liquid	High weight, thermal inertia
Serpentine absorber	Only two solder points in tube system	Higher pressure loss than tube register
Tube register (full-surface absorber)	Lower pressure loss than serpentine absorber	Many solder points in tube system; expensive
Tube register (vane absorber)	Lower pressure loss than serpentine absorber	Many solder points in tube system

RADIATION AND INTERACTION WITH MATTER

When short-wave sunlight (wavelength 0.3–3.0 μm) hits an object, such as a solar cover, it is reflected more or less strongly according to the surface structure (material, roughness and colour). White surfaces reflect much more than dark surfaces. The proportion of reflected radiation (especially for glass panes) also depends on the angle of incidence of the radiation (Fresnel's law). The remaining portion is absorbed by the object or, for translucent material, is allowed to partially pass through. Finally, the absorbed portion is converted into long-wave thermal radiation (wavelengths 3.0–30 μm) and radiated according to the surface structure.

These processes are described physically as the degrees of reflection, absorption, transmission and emissivity of a body.

- *degree of reflection, ρ :*

$$\rho = \frac{\text{Reflected radiation}}{\text{Incident radiation}}$$

- *degree of absorption (absorption coefficient), α :*

$$\alpha = \frac{\text{Absorbed radiation}}{\text{Incident radiation}}$$

- *degree of transmission, τ :*

$$\tau = \frac{\text{Transmitted radiation}}{\text{Incident radiation}}$$

- *emissivity, ϵ :*

$$\epsilon = \frac{\text{Emitted radiation}}{\text{Absorbed radiation}}$$

The variables ρ , α , τ and ϵ are dependent on the material and wavelength. The sum of ρ , α and τ is equal to 1 (100%).

For solar thermal technology the *Stefan–Boltzmann law* is significant. This says that a body emits radiation corresponding to the fourth power of its temperature.

$$\dot{Q} = \sigma T^4$$

where \dot{Q} is the emitted thermal radiation (W/m^2), σ is the Stefan–Boltzmann constant = 5.67×10^{-8} ($\text{W}/\text{m}^2\text{K}^4$), and T is the absolute body temperature (K).

In order to reduce the emissions and hence increase the efficiency of the collectors, new absorber coatings are being developed continuously.

As a material for the absorber plate, copper possesses the requisite good thermal conduction. The thermal transmission between absorber plate and tube takes place through the best possible heat-conducting connection.

A further factor for a large energy yield is a low heat capacity, which permits a fast reaction to the ever-changing level of solar radiation. For absorbers with flow channels this is lower (0.4–0.6 l of heat transfer liquid per m^2 (0.008–0.01 gallons per ft^2) of absorber surface) than for full-surface flow absorbers, such as for example cushion absorbers with 1–2 l/m^2 (0.02–0.05 gallons/ ft^2).

INSULATION

To reduce heat losses to the environment by thermal conduction, the back and edges of the collector are heat insulated.

As maximum temperatures of 150–200°C (302–392°F) (when idle) are possible, mineral fibre insulation is the most suitable here. It is necessary to take account of the adhesive used. This must not vaporize at the temperatures given, otherwise it could precipitate onto the glass pane and impair the light-transmitting capacity.

Some collectors are equipped with a barrier to reduce convection losses. This takes the form of a film of plastic, such as Teflon, between the absorber and the glass pane. In some countries collectors are offered with translucent heat insulation under the glass panel.

HOUSING AND GLASS PANEL

The absorber and thermal insulation are installed in a box and are enclosed on the top with a light-transmitting material for protection and to achieve the so-called greenhouse effect.

Glass or occasionally plastic is used for the cover. Low-ferrous glass (which is highly transparent) is mainly used, in the form of safety glass, 3–4 mm (0.12–0.16 inches) thick. The light-transmitting coefficient is maximally 91%.

Requirements for the transparent cover are as follows (see also Table 2.3):

- high light transmittance during the whole service life of the collector
- low reflection
- protection from the cooling effects of the wind and convection
- protection from moisture
- stability with regard to mechanical loads (hailstones, broken branches etc.).

The first products with special coatings on the glazing to reduce reflections and thus increase the efficiency are now coming onto the international market.

SEALS

Seals prevent the ingress of water, dust and insects. The seals between the glass panel and the housing consist of EPDM (ethylene propylene diene monomer) material or silicon rubber. The rear wall is sealed to the frame with silicon. For tube entry, seals made of silicon or fluorinated rubber are suitable (maximum application temperature 200°C (392°F)).

Table 2.3.
Characteristics of different cover
and box materials

Cover	Glass	Plastic		
Transmission values	Long-term stability	Deterioration due to embrittlement, tarnishing, scratches		
Mechanical stability	Stable	Stable		
Cost	Higher	Lower		
Weight	Higher	Lower		
Housing	Aluminium	Steel plate	Plastic	Wood, bonded waterproof
Weight	Low	High	Medium	High
Processing	Easy	Easy	Medium	Difficult
Energy requirement	High	Low	Medium	Low
Cost	High	Low	Low	Medium
Other	Increase in energy recovery time, recyclable	Hardly ever used	Seldom used	Ecological material only for in-roof mounting

2.2.2.2 WORKING PRINCIPLE OF A GLAZED FLAT-PLATE COLLECTOR

See Figure 2.10.

The irradiance (G_0) hits the glass cover. Here, even before it enters the collector, a small part of the energy (G_1) is reflected at the outer and inner surfaces of the pane. The selectively coated surface of the absorber also reflects a small part of the light (G_2) and converts the remaining radiation into heat. With good thermal insulation on the rear and on the sides of the collector using standard, non-combustible insulating materials such as mineral wool and/or CFC (chlorofluorocarbon)-free polyurethane foam sheets, the energy losses through thermal conduction (Q_1) are reduced as much as possible.

The transparent cover on the front of the collector has the task of reducing losses from the absorber surface through thermal radiation and convection (Q_2). By this means only convection and radiation losses from the internally heated glass pane to the surroundings occur.

From the irradiated solar energy (G_0), because of the various energy losses G_1 , G_2 , Q_1 and Q_2 , the remaining heat (Q_A) is finally usable.

COLLECTOR EFFICIENCY COEFFICIENT

The *efficiency*, η , of a collector is defined as the ratio of usable thermal power to the irradiated solar energy flux:

$$\eta = \frac{\dot{Q}_A}{G_0}$$

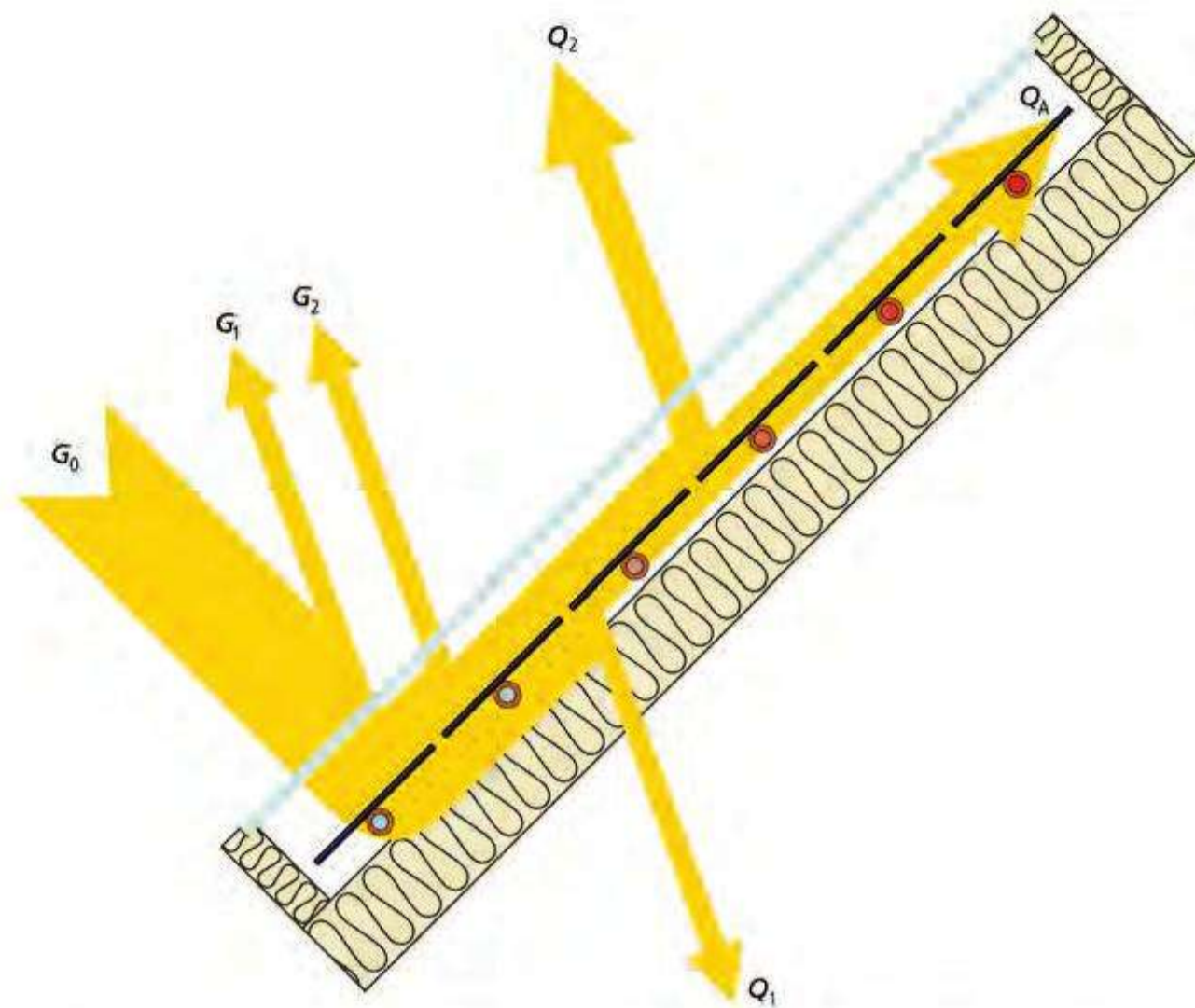

Figure 2.10.
Energy flows in the collector

irradiance (G_0) – reflection losses (G_1 and G_2) – thermal losses (\dot{Q}_1 and \dot{Q}_2) – available heat quantity (\dot{Q}_A)

The efficiency is influenced by the design of the collector: more specifically, it is influenced by the particular optical (G_1 and G_2) and thermal (\dot{Q}_1 and \dot{Q}_2) losses (see Figure 2.11).

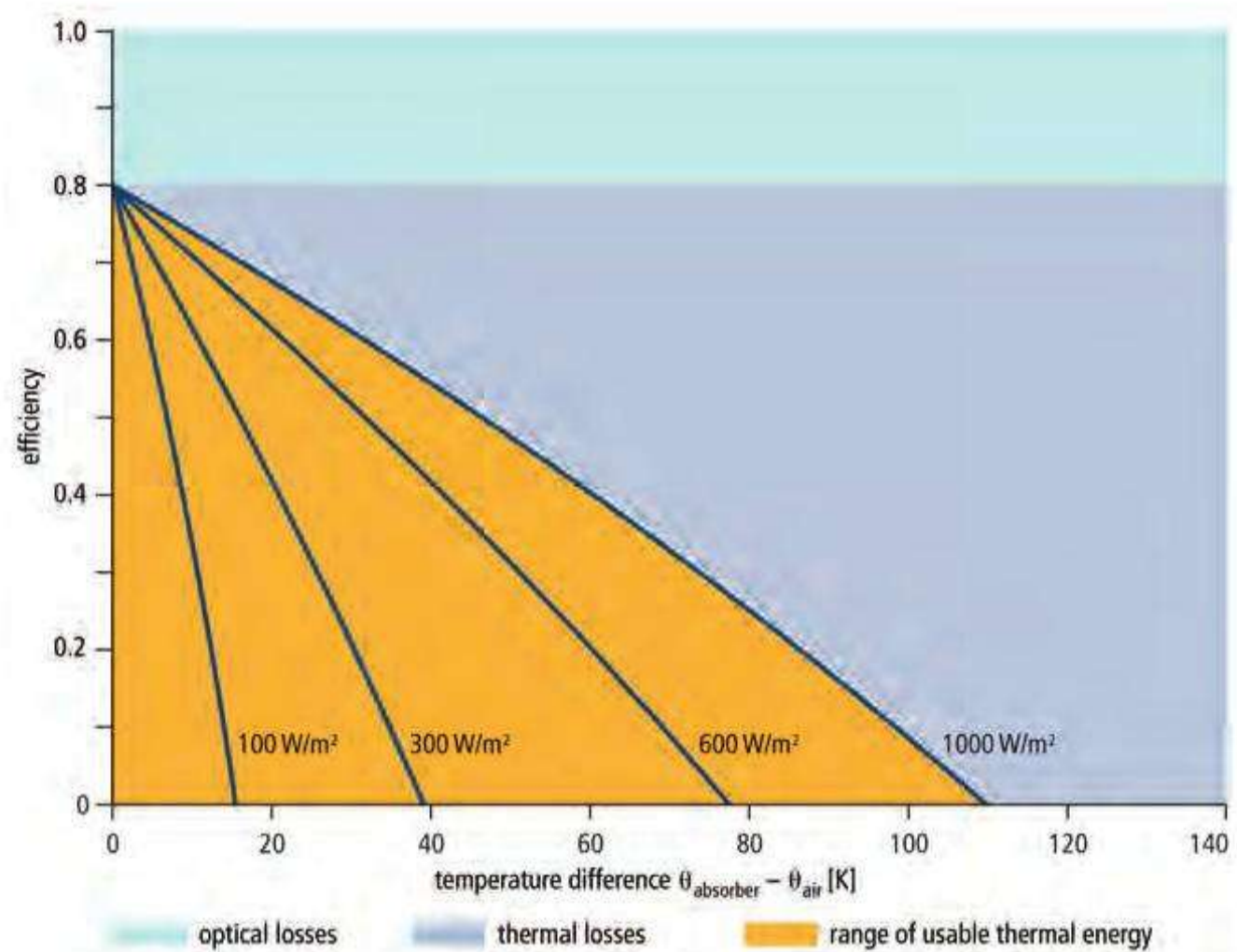

Figure 2.11.
Optical and thermal losses

The optical losses describe the proportion of the solar irradiance that cannot be absorbed by the absorber. They are dependent on the transparency of the glass cover (degree of transmission, τ) and the absorption capacity of the absorber surface (degree of absorption, α) and are described by the *optical efficiency*:

$$\eta = (\tau\alpha)$$

The thermal losses are dependent on the temperature difference between the absorber and the outside air, on the insolation, and on the construction of the

collector. The influence of the construction is described by the *heat loss coefficient*, k (or k -value), which is measured in $\text{W/m}^2\text{K}$.

As the temperature difference between the absorber and the outside air increases, the heat losses increase for a constant irradiance, so that the efficiency reduces. It is therefore important for the yield of a thermal solar system to ensure a low return temperature and a high irradiance.

CHARACTERISTIC CURVE EQUATION AND THE THERMAL LOSS COEFFICIENT

The efficiency of a collector can in general be described by:

$$\eta = \frac{\dot{Q}_A}{G}$$

where \dot{Q}_A is the available thermal power (W/m^2), and G is the irradiance incident on the glass pane (W/m^2).

The available thermal power is calculated from the available irradiance at the absorber, converted into heat, minus the thermal losses through convection, conduction and radiation:

$$\dot{Q}_A = G_A - \dot{Q}_L$$

where G_A is the available irradiance (W/m^2), and \dot{Q}_L represents the thermal losses (W/m^2).

The available irradiance is obtained mathematically from the product of: the irradiance hitting the glass pane, G ; the degree of transmission of the glass, τ ; and the degree of absorption of the absorber, α :

$$G_A = G\tau\alpha$$

The thermal losses are dependent on the temperature difference between the absorber and the air, $\Delta\theta$. To a first approximation (for low absorber temperatures) this relationship is linear, and can be described by the heat loss coefficient, k ($\text{W/m}^2\text{K}$):

$$\dot{Q}_L = k\Delta\theta$$

If the various values are substituted into the above equation, we obtain for the collector efficiency:

$$\eta = \frac{G\tau\alpha - k\Delta\theta}{G}$$

$$\eta = \frac{G\tau\alpha}{G} - \frac{k\Delta\theta}{G}$$

At higher absorber temperatures the thermal losses no longer increase linearly with the temperature difference but instead increase more strongly (by the power of 2) as a result of increasing thermal radiation. The characteristic line therefore has some curvature and the equation in a second order approximation is:

$$\eta = \eta_0 - \frac{k_1\Delta\theta}{G} - \frac{k_2\Delta\theta^2}{G}$$

where k_1 is the linear heat loss coefficient ($\text{W/m}^2\text{K}$), and k_2 is the quadratic heat loss coefficient ($\text{W/m}^2\text{K}^2$).

In the literature a k_{eff} value is also sometimes given. This is calculated from the k_1 and k_2 values:

$$k_{\text{eff}} = k_1 + k_2\Delta\theta$$

when k -values are discussed in the following sections the k_1 value is meant.

NUMERICAL VALUES

The characteristic numbers given are the criteria for comparing the qualities of different collectors. Good glazed flat-plate collectors with spectral-selective absorbers have an optical efficiency, η_0 , greater than 0.8 and a k -value of less than $3.5 \text{ W/m}^2\text{K}$.

The average annual efficiency of a complete system with glazed flat-plate collectors is 35–40%. With an annual amount of solar radiation of 1000 kWh/m^2 (as in central Europe) this corresponds to an energy yield of $350\text{--}400 \text{ kWh/m}^2\text{a}$. In sunnier climates, the radiation may increase to over 2200 kWh/m^2 and the corresponding energy yield of the system may then surpass $770\text{--}880 \text{ kWh/m}^2\text{a}$. These yields assume a sensibly dimensioned system and corresponding consumption.

ADVANTAGES AND DISADVANTAGES OF A GLAZED FLAT-PLATE COLLECTOR

Advantages:

- It is cheaper than a vacuum collector (see section 2.2.3).
- It offers multiple mounting options (on-roof, integrated into the roof, façade mounting and free installation).
- It has a good price/performance ratio.
- It has good possibilities for do-it-yourself assembly (collector construction kits).

Disadvantages:

- It has a lower efficiency than vacuum collectors, because its k -value is higher.
- A supporting system is necessary for flat roof mounting (with anchoring or counterweights).
- It is not suitable for generating higher temperatures, as required for, say, steam generation, or for heat supplies to absorption-type refrigerating machines.
- It requires more roof space than vacuum collectors do.

2.2.2.3 SPECIAL DESIGNS

COLLECTORS MADE TO MEASURE

Apart from the standard formats, different manufacturers also offer collectors that are delivered either ‘custom-made’ on the building site or assembled on the roof. In this way solutions are possible even if standard modules cannot be used due to the conditions of the roof. Besides the usual rectangular form, different dimensions, e.g. triangular designs, can be realized (e.g. Buschbeck Solar).



Figure 2.12.
Source: BuSo, Augustenburg

COLLECTORS IN THE SCREEN LINE DIMENSION OF SKYLIGHTS

At present several manufacturers provide flat plate collectors (and PV panels) in the skylight assembly of their window products. The evenly glassed surface results in a uniform appearance of the roof (e.g. Roto, Schüco, Velux, Sunrain, Altemate Energy Technologies LLC).



Figure 2.13.
Source: VELUX, Hamburg

STORAGE COLLECTORS/INTEGRAL COLLECTOR STORAGE SYSTEMS (ICS) OR 'BATCH' SYSTEMS (SOURCE: US DEPARTMENT OF ENERGY)

Here the collector and water store form a construction unit. The following components are omitted: Heat exchanger, pipings for the solar circuit, controller and circulation pump. The storage collector is installed directly into the water supply line. Reheating is carried out efficiently by a thermally regulated instantaneous water heater (gas or electrical). The compactness of the storage collector offers an interesting solution for special applications, e.g. for weekend houses (Manufacturer: Solarpower GmbH, Plauen/Saxonia, SunEarth Inc., Haining Maxsun Solar Water Heater Co., Ltd).

HYBRID COLLECTOR

Hybrid collectors can be realized as a combination of solar panels (PV) with liquid-based collectors as well as with air-based collectors. The combination with solar panels is reasonable, because during the solar electricity conversion only about 12% (with crystalline silicon) of the solar radiation converts into electricity, whereas the remainder converts into heat. This heat is used in the hybrid collector to either heat up a liquid or air (see Section 8.2.1.8).

Here, the solar cells are arranged electrically in an isolated manner on the surface of a liquid (or air) cooled absorber, with which they are thermally connected. The electrical yields are approximately the same as conventional photovoltaic systems, and the thermal yields are within the range of collectors without selective coating. The central problem with hybrid collectors is the high and in part more persistent temperature load of the solar cells in the event of stagnation. Hybrid collectors in combination with PV panels are currently produced in Germany by the manufacturers Grammer Solar GmbH (PV-air, project-related) and Solarhybrid AG (PV-Fluid). Non-German manufacturers include Aidt Miljø A/S Solar Heating (DK) and Conserval Engineering, Inc. (CAN).

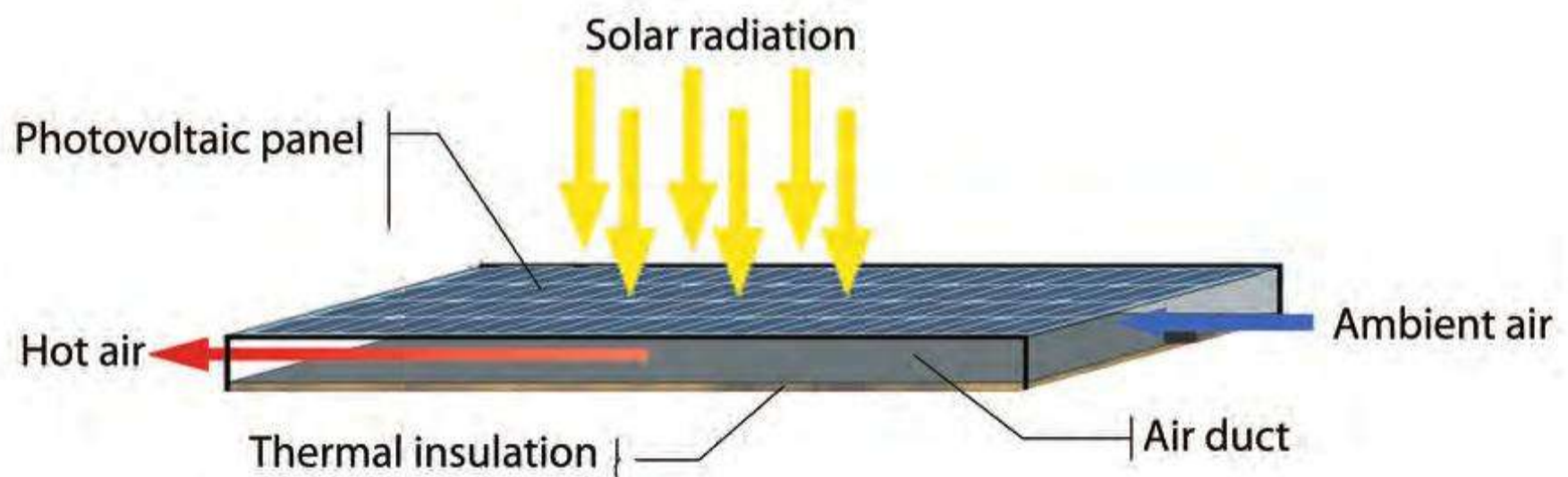

Figure 2.14.
Schematic diagram of the
construction of a Hybrid PV/T air
collector (Manufacturer: Grammer
Solar GmbH, Amberg)

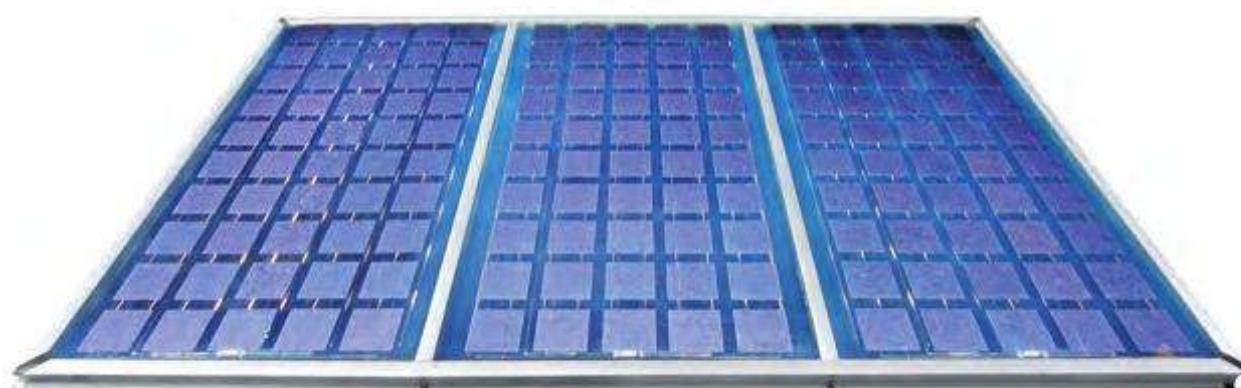

Figure 2.15a.
Photo-thermal collector (Manufacturer:
Solarhybrid AG, Markranstädt (Leipzig))

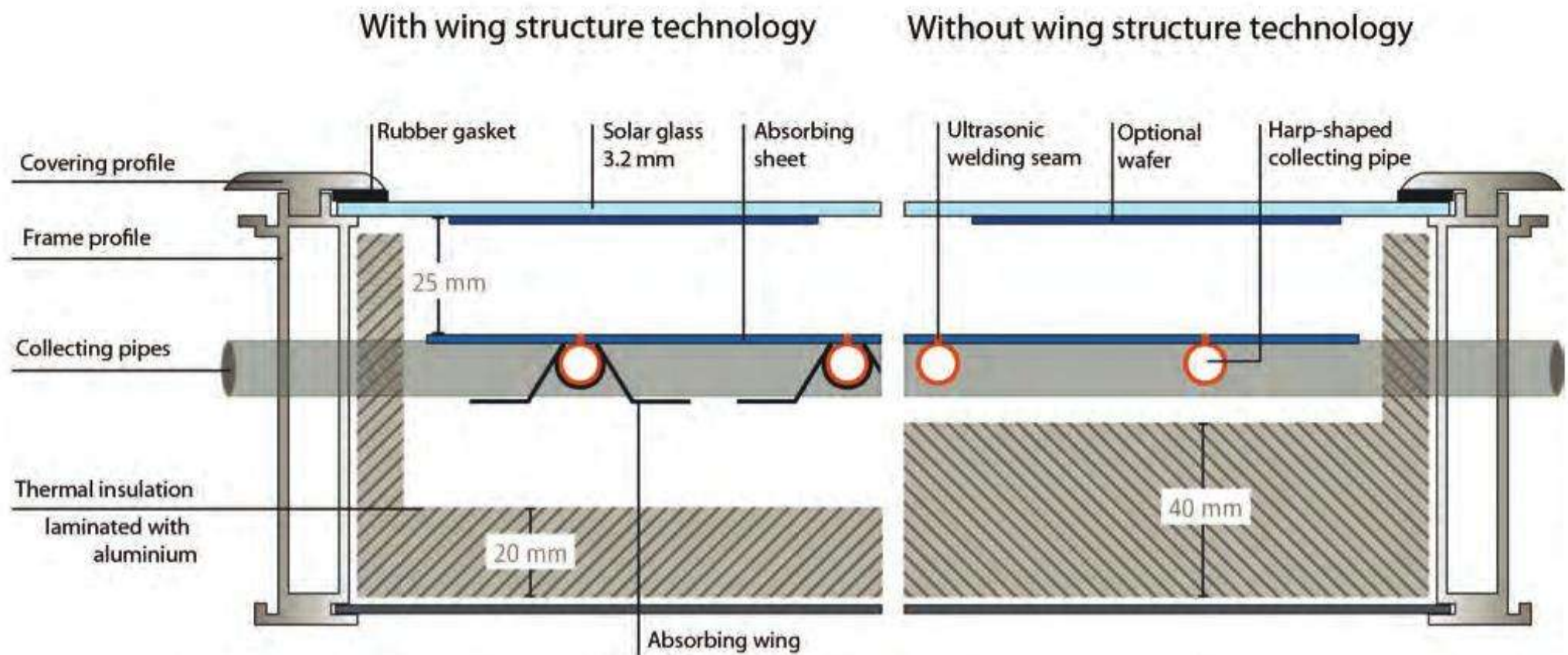

Figure 2.15b.
Section through a photo-thermal collector (Manufacturer: Solarhybrid AG, Markranstädt (Leipzig))

The company ERSOTEC Solartechnik GmbH in Berlin developed a hybrid collector, which combines the heat transfer media air and fluid. Because air heats up faster than water and at a low temperature level can be used for building space heating, the operating time of the collector increases along with the collector energy yield (up to 750 kWh/m²a).

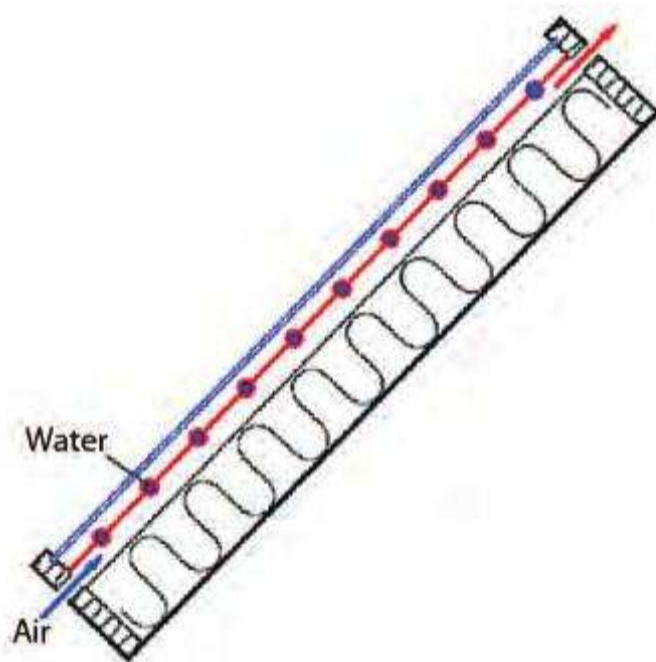

Figure 2.16a. (left)
Schematic diagram of the construction of the hybrid air-water collector HSK 2005 (Manufacturer: ERSOTEC Solartechnik GmbH, Berlin)



Figure 2.16b. (right)
Mode of operation of a hybrid air-water collector HSK 2005 (Manufacturer: ERSOTEC Solartechnik GmbH, Berlin)

2.2.3 Vacuum collectors

2.2.3.1 EVACUATED TUBE COLLECTORS

To reduce the thermal losses in a collector, glass cylinders (with internal absorbers) are evacuated in a similar way to Thermos flasks (Figure 2.17). In order to completely suppress thermal losses through convection, the volume enclosed in the glass tubes must be evacuated to less than 10⁻² bar (1 kPa). Additional evacuation prevents losses through thermal conduction. The radiation losses cannot be reduced by creating a vacuum, as no medium is necessary for the transport of radiation. They are kept low, as in the case of glazed flat-plate collectors, by selective coatings (small ϵ value). The heat losses to the surrounding air are therefore significantly reduced. Even with an absorber temperature of 120°C (248°F) or more the glass tube remains cold on the outside. Most vacuum tubes are evacuated down to 10⁻⁵ bar.

Figure 2.17.
The principle of vacuum thermal insulation

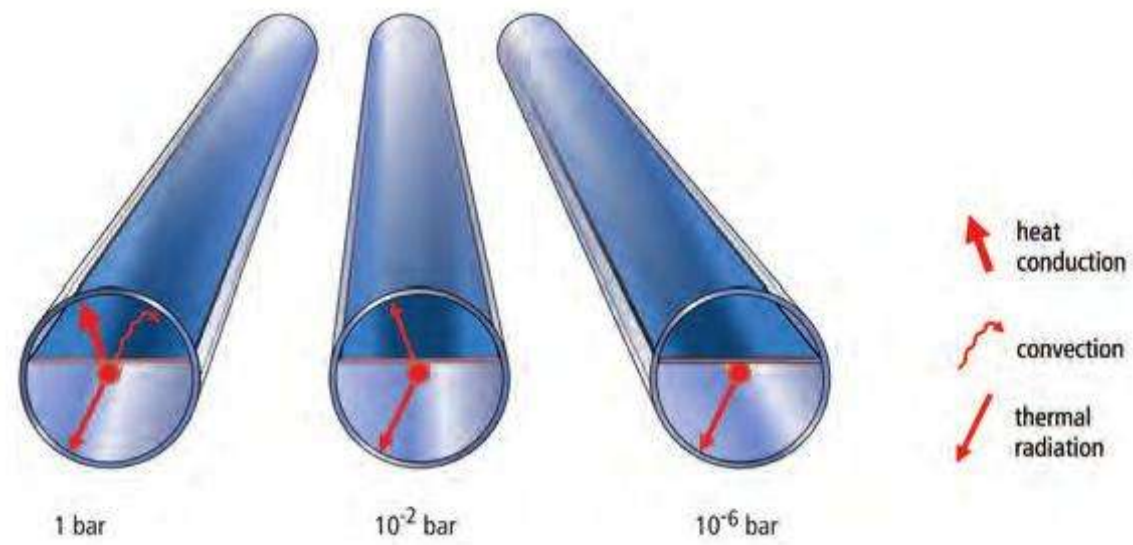

ABSORBER, GLASS TUBE, COLLECTOR AND DISTRIBUTOR BOXES

For evacuated tube collectors, the absorber is installed as either flat or upward-vaulted metal strips or as a coating applied to an internal glass bulb in an evacuated glass tube. The forces arising from the vacuum in the tube are very easily taken up by the high compression strength of the tubular form.

An evacuated tube collector consists of a number of tubes that are connected together and which are linked at the top by an insulated distributor or collector box, in which the feed or return lines run. At the base the tubes are fitted to a rail with tube holders. There are two main sorts of evacuated tube collector: the direct flow-through type and the heat-pipe type.

DIRECT FLOW-THROUGH EVACUATED TUBE COLLECTORS

In this design (Figure 2.18) the heat transfer medium is either led via a tube-in-tube system (coaxial tube) to the base of the glass bulb, where it flows back in the return flow and thereby takes up the heat from the highly spectral-selective absorber, or it flows through a U-shaped tube.

Direct flow-through evacuated tube collectors can be oriented towards the south, but they can also be mounted horizontally on a flat roof.

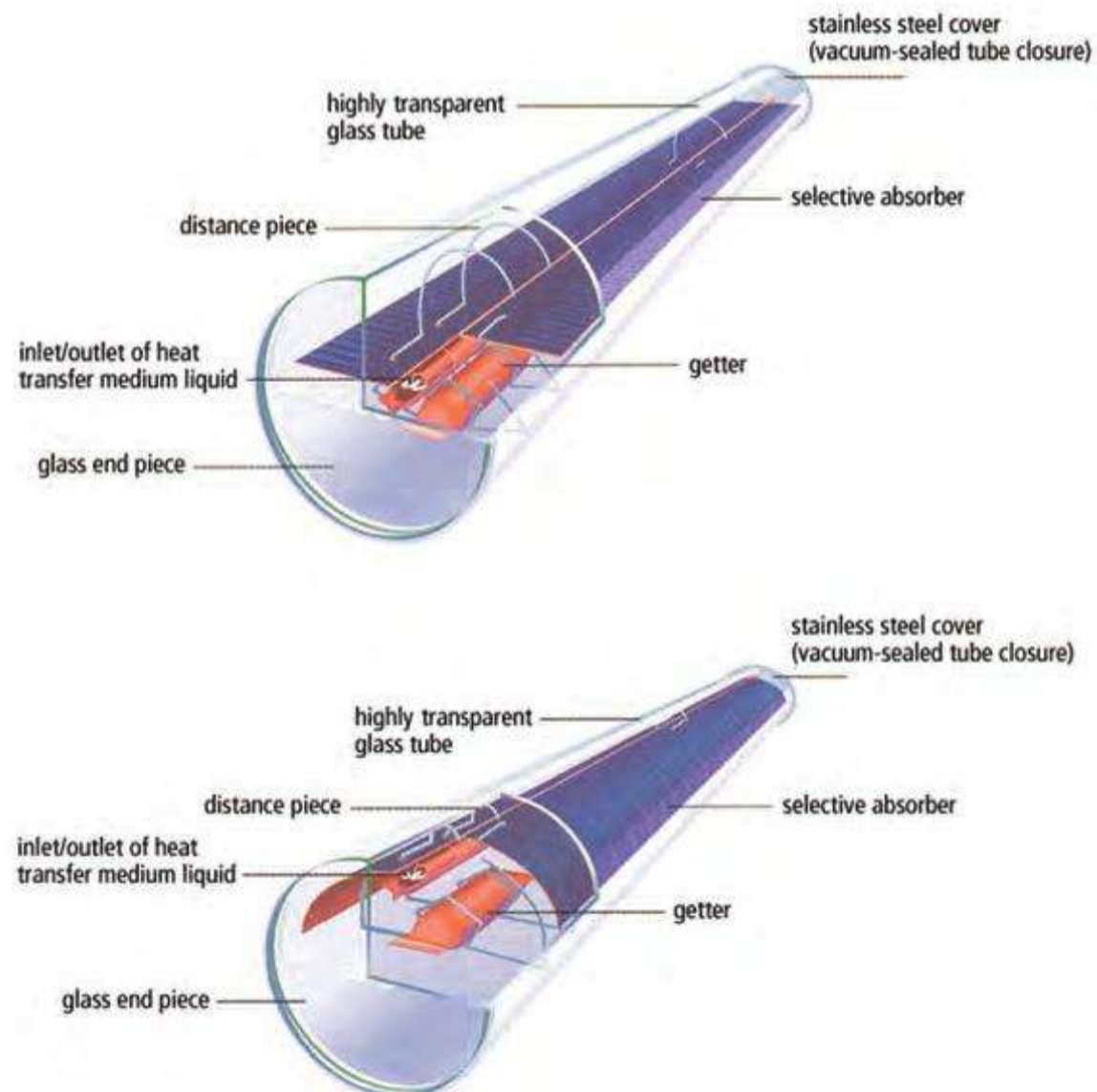

Figure 2.18.
Cross-sectional view of a direct flow-through evacuated tube collector (Lux 2000 and 2000R, ThermoLUX, Kempten)

A particular design of direct flow-through evacuated tube collector marketed in some countries is the *Sydney collector* (Figure 2.19). The collector tube consists of a vacuum-sealed double tube. The inner glass bulb is provided with a selective coating of a metal carbon compound on a copper base. Into this evacuated double tube is plugged a thermal conducting plate in connection with a U-tube to which the heat is transferred. Several tubes are combined into one module (between 6 and 21, according to supplier). To increase the radiation gain the collector is fitted with external reflectors in the sloping roof version. The flat roof version requires a light background such as gravel or reflective foil, as it does not have reflectors.

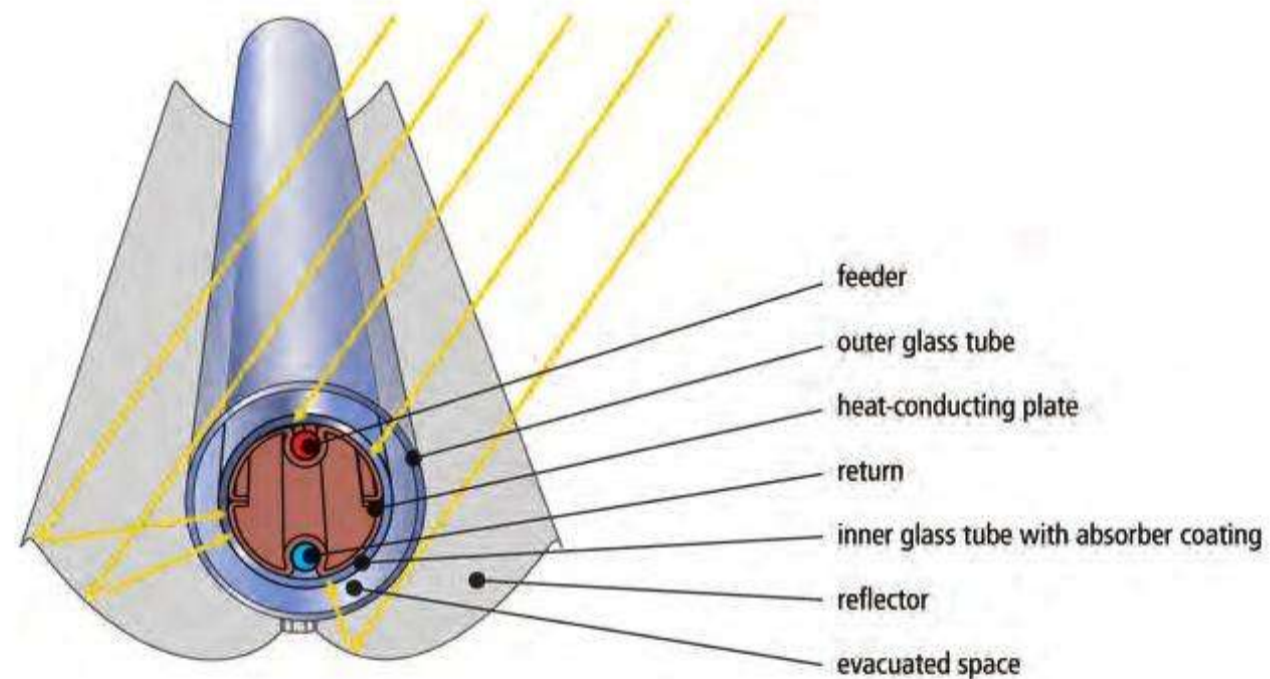
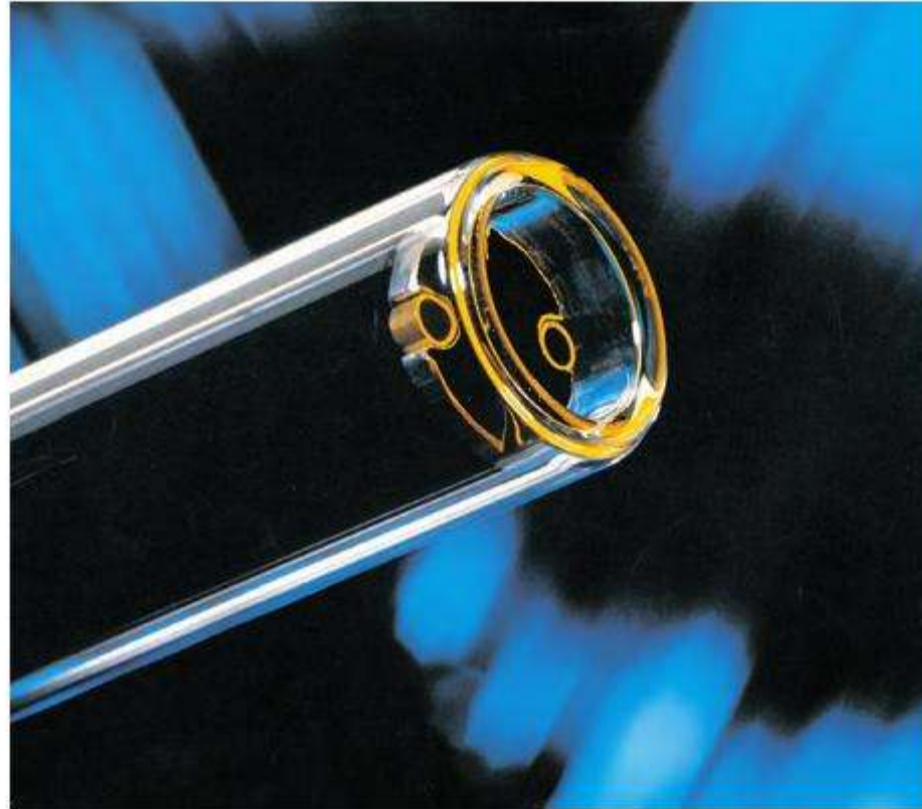

Figure 2.19.
Sydney tube (microtherm, Lods)

HEAT-PIPE EVACUATED TUBE COLLECTORS

In this type of collector a selectively coated absorber strip, which is metallicly bonded to a heat pipe, is plugged into the evacuated glass tube. The heat pipe is filled with alcohol or water in a vacuum, which evaporates at temperatures as low as 25°C (77°F). The vapour thus occurring rises upwards. At the upper end of the heat pipe the heat released by condensation of the vapour is transferred via a heat exchanger (condenser) to the heat transfer medium as it flows by. The condensate flows back down into the heat pipe to take up the heat again. For appropriate functioning of the tubes they must be installed at a minimum slope of 25°.

Heat pipe evacuated tube collectors are offered in two versions, one with a dry and one with a wet connection. For the dry type (Figure 2.20), the condenser completely surrounds the collector, and provides a good heat-conducting link to a double tube heat exchanger: The heat transfer takes place from the condenser via the tube wall to the heat transfer medium. This permits defective tubes to be exchanged without emptying the solar circuit.

For the wet connection (Figure 2.21) the condenser is immersed in the heat transfer medium. If tubes have to be exchanged, it is necessary to at least empty the collection device at the top.

The UK manufacturer Thermomax has designed a stagnation temperature limiting system, in which a *memory spring* is used to close the condenser from a temperature of 130°C (266°F) and hence thermally decouple the system from the collection device.

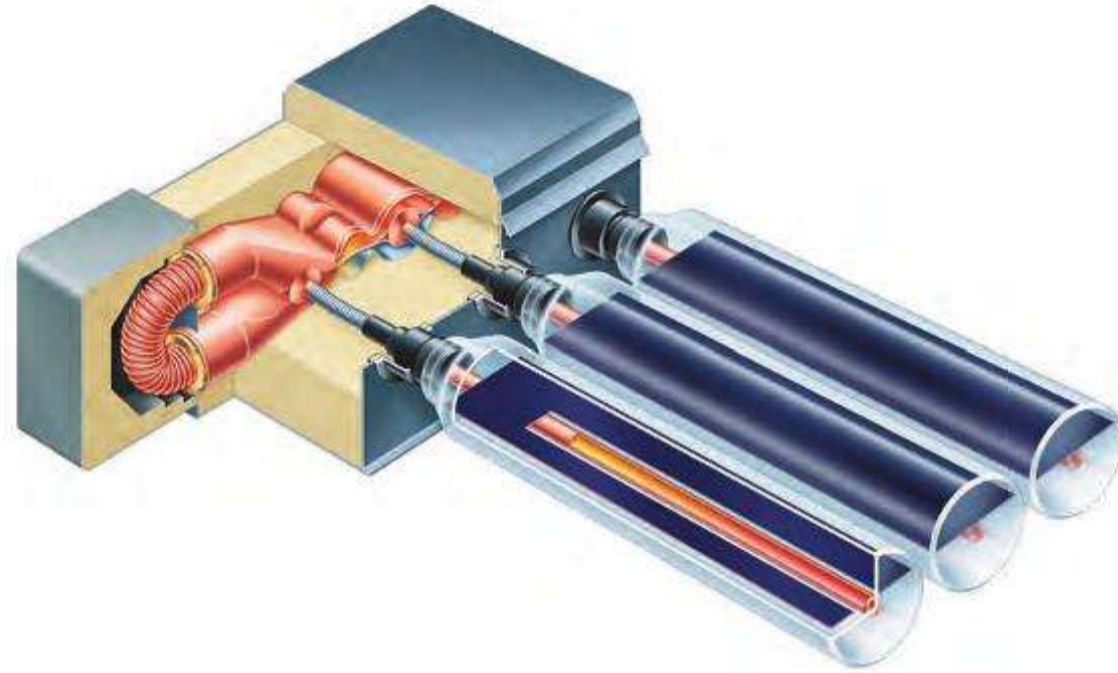

Figure 2.20.
Cross-section of heat-pipe evacuated
tube collector with dry connection.
Source: Viessmann, Allendorf

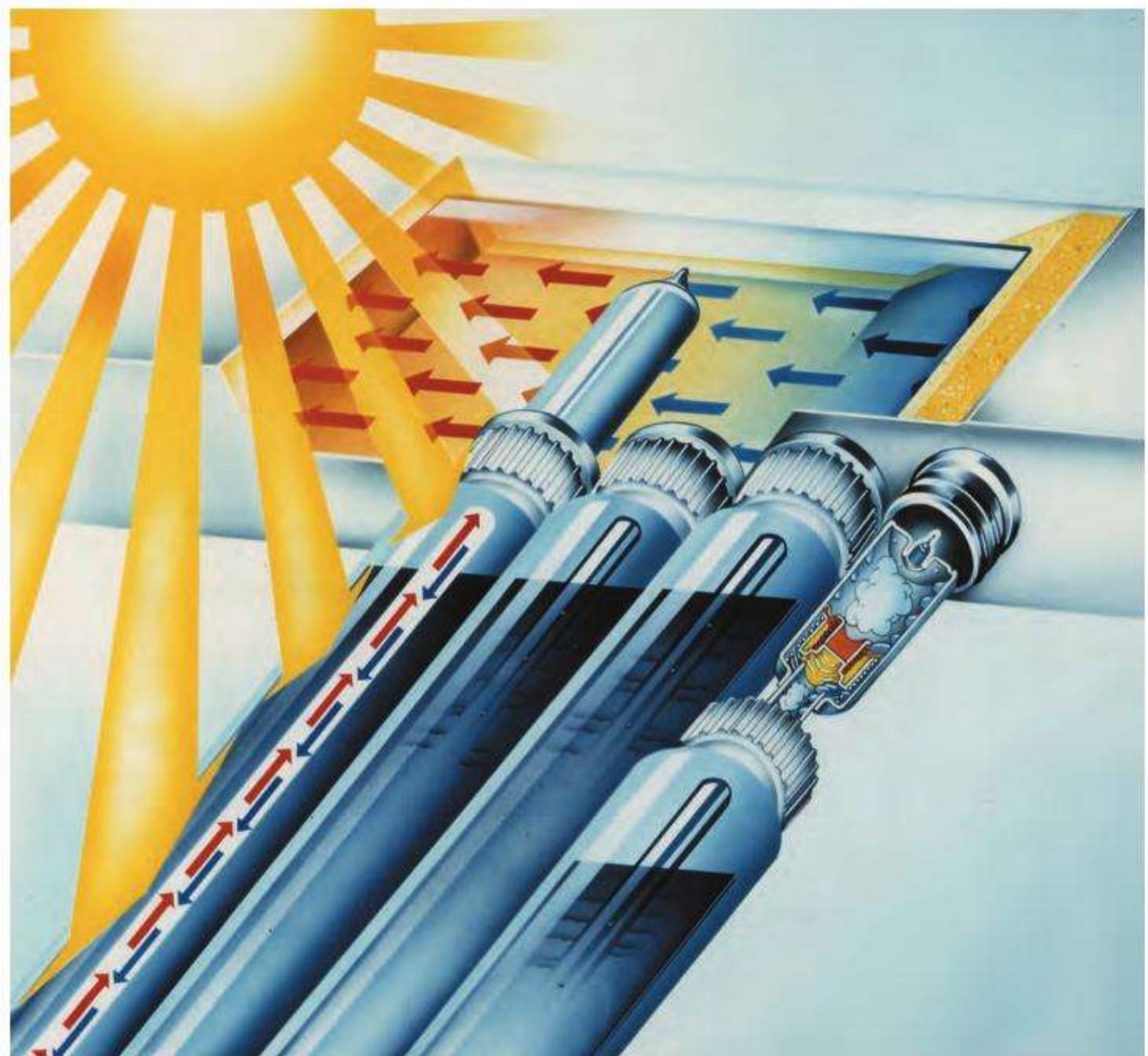

Figure 2.21.
Cross-section of a heat-pipe evacuated
tube collector and condenser with
memory spring and wet connection.
Source: Elco-Klöckner, Hechingen

NUMERICAL VALUES

The optical efficiency of evacuated tube collectors is somewhat lower than that of glazed flat-plate collectors because of the tube form ($\eta_0 = 0.6\text{--}0.8$), but because of the better heat insulation the k -value is below $1.5 \text{ W/m}^2\text{K}$.

The average annual efficiency of a complete system with evacuated tube collectors is between 45% and 50%. With an annual solar irradiance of 1000 kWh/m^2 (as in central Europe) this corresponds to an energy yield of $450\text{--}500 \text{ kWh/m}^2\text{a}$. These yields assume appropriate dimensioning of the system.

ADVANTAGES AND DISADVANTAGES OF AN EVACUATED TUBE COLLECTOR

Advantages:

- It achieves a high efficiency even with large temperature differences between absorber and surroundings.
- It achieves a high efficiency with low radiation.
- It supports space heating applications more effectively than do glazed flat-plate collectors.
- It achieves high temperatures, for example for steam generation or air-conditioning.
- It can be easily transported to any installation location because of its low weight; sometimes the collector is assembled at the installation site.
- By turning the absorber strips (in the factory or during assembly) it can be aligned towards the sun (only relevant for certain products).
- In the form of direct through-flow tubes it can be mounted horizontally on a flat roof, hence providing less wind load and lower installation costs. In this way penetration of the roof skin is avoided.

Disadvantages:

- It is more expensive than a glazed flat-plate collector.
- It cannot be used for in-roof installation.
- It cannot be used for horizontal installation for heat pipe systems (inclination must be at least 25°).

Table 2.4.

Manufacturer	OEM producer	Tube type	Tube origin	Tube diameter (mm)	Tube length (mm)	Glass thickness (mm)	Glass type	Absorber-coating	Absorber material	Absorber junction	Material thermal baffle (Sydney)
AMK-Collectra, Switzerland	Yes	Sydney	AMK China	47/58	1900	1,6/2	Borosilicate	N.A.	N.A.	Sputtered on-glass	Alu
Consolar, Germany	Yes	Sydney, direct flow	China	47	1803	1,7	Borosilicate	SC-coating ¹⁾	Borosilicate	Pressed between glass/Alu/CuNi	Alu
Elco/MTS Group, Italy	No	direct flow	China	70	1790	N.A.	Borosilicate	Selective	Aluminium	Bounded absorber	—
ESE, Belgium	Yes	Sydney, direct flow through	China	47	1500	N.A.	Borosilicate	Selective	N.A.	Sputtered on-glass	Alu
Philippine, Germany	Yes	direct flow ¹⁾	Germany (Narva)	56	2000	1,8	Calcium carbonate natron	Tinox	Copper	Ultrasound	—
Ritter Solar, Germany	Yes	Sydney, direct flow	China	47 (37 ²⁾)	1500 / 1800 / 1920	1,6	Borosilicate	Al-N	Glass	Sputtered on-glass	Alu
Solvis, Germany	No	Sydney	China	58	1800	1,8	Borosilicate	SC-coating ³⁾	Glass	Pressed between glass/Alu/CuNi	Alu

Manufacturer	Reflecting material (with Sydney)	Material header and frame	Material assembly robotics	Collector's annual yield ⁴⁾	Collector's hydraulic system	Stagnation temperature (°C)	Certification	Internet link
AMK-Collectra, Switzerland	Without reflector	Alu	Alu	N.A.	N.A.	N.A.	Solar Keymark	www.amk-solac.com
Consolar, Germany	Alu ³⁾ , CPC	Copper header, stainless steel frame	Stainless steel /Alu ³⁾	568	6 tubes in a row	250	Solar Keymark	www.consolar.de
Elco/MTS Group, Italy	—	Alu powder-coated	Steel, galvanized, powder-coated	648	3 or 4 times 5 tubes in a row	206	Solar Keymark	www.elco.net
ESE, Belgium	Alanod	Alu	Stainless steel	N.A.	N.A.	N.A.	Solar Keymark	www.es-e-solar.com
Philippine, Germany	—	Special header hard integral PU, Alu frame	N.A. ²⁾	630	2 times 5 tubes in a row	296	Solar Keymark	www.philippine.de/kunststoffe
Ritter Solar, Germany	Alu, CPC	Alu	Galvanized with Alu, stainless steel or steel	589	All tubes parallel, 2 tubes in a row or 3 tubes in a row	272	Solar Keymark	www.rittersolar.de
Solvis, Germany	Alu ³⁾ , even	ABS plastic housing/ASA aluminium frame	Alu/stainless steel	N.A.	Double meander, 2 times 6 tubes in a row	222	In preparation	www.solvis.com

¹⁾ From Autumn 2008 also heat pipes

²⁾ Internal diameter

³⁾ High-gloss Alu with weatherproof ceramic protection layer

⁴⁾ At an solar surface 790

⁵⁾ Steel copper aluminium nitride

⁶⁾ Rooftop mounts: 30 degrees with stainless steel roof hooks, flat roof and façade assembly: aluminium frame

⁷⁾ Belongs to scope of delivery

⁸⁾ According to ITW-method, 5 m² aperture

2.2.4 Collector accessories

Collectors cannot be installed without additional materials. They are:

- for on-roof installation: roof hooks, special bricks, rails, vent tiles
- for in-roof installation: covering frames
- for flat roof or free installation: bracing, counterweights, bearers.

For more information see Chapter 4.

2.2.5 Collector characteristic curves and applications

Figure 2.22 shows typical efficiency curves and areas of application with the same global solar irradiance for the following collector types: swimming pool absorber, glazed flat-plate collector, and evacuated tube collector. At $\Delta\theta = 0$ each collector type is at its highest efficiency (η_0). At its maximum temperature – that is, when it has reached its stagnation temperature – the efficiency equals zero.

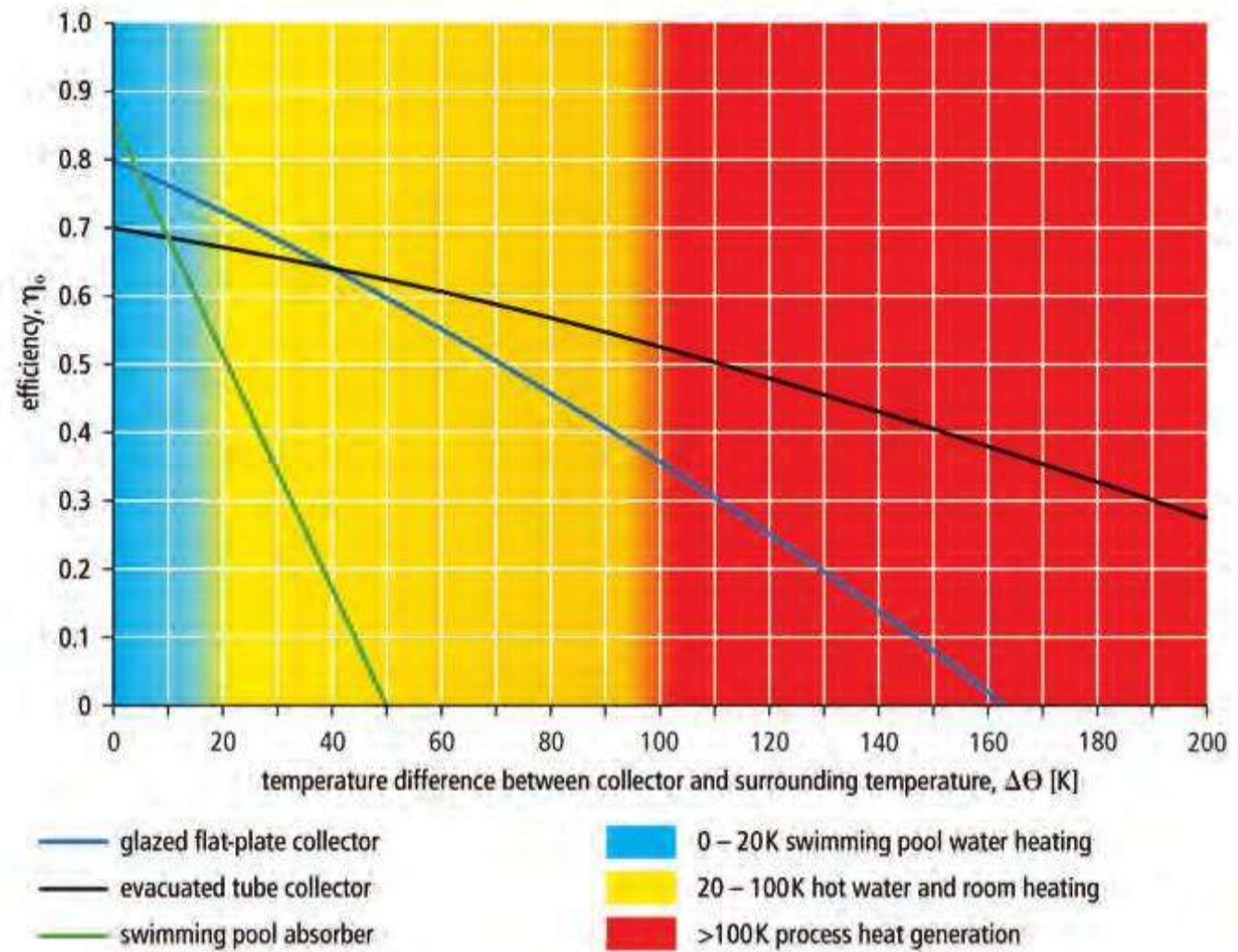

Figure 2.22. Efficiency characteristic curves for different types of collector and their areas of application (at irradiation of $1000\text{W}/\text{m}^2\text{K}$)

2.2.6 Stagnation temperature

If the circulation pump fails in the event of strong solar irradiance, or if – for example in holiday times – no hot water is used so that the store is hot ($60\text{--}90^\circ\text{C}$; $140\text{--}194^\circ\text{F}$) and the system switches off, no more heat is drawn from the collector. In this situation the absorber heats up until the heat losses through convection, heat radiation and heat conduction reach the thermal output of the absorber. The greater the insolation, the higher the stagnation temperature. Well-insulated glazed flat-plate collectors achieve maximum stagnation temperatures of $160\text{--}200^\circ\text{C}$ ($320\text{--}392^\circ\text{F}$), evacuated tube collectors $200\text{--}300^\circ\text{C}$ ($392\text{--}572^\circ\text{F}$), or – with a reflector – as much as 350°C (662°F).

STEAM GENERATION WITH FLOW-THROUGH EVACUATED TUBE COLLECTORS

The generation of steam in connecting pipes is considerably more pronounced for evacuated tube collectors than for glazed flat-plate collectors. In the connecting pipes, convective heat transport processes occur in the liquid–steam phase. Therefore the thermal transfer medium is converted to the steam condition in a large section of the connecting pipeline. This condition, which can be particularly significant for short pipes, such as in central roof heating units, has the following consequences:

All materials in the solar circuit must be checked with respect to the increased stagnation condition requirements (insulation materials, solders, temperature sensors). The connecting technology must be matched to the temperatures in the solar circuit, 160°C (320°F) or more. Soft solders cannot therefore be used. Expansion vessels must never be installed in the vicinity of tube collectors: longer and non-insulated supply lines must be provided to the expansion vessel. The additional volume of steam in other parts of the solar circuit must be taken into account when dimensioning the vessel.

For heat-pipe tubes the thermal load is significantly lower, as thermal decoupling between tube and collector takes place at temperatures of no more than 150°C (320°F). The whole content then has vaporized, and no further heat transmission takes place.

2.3 Heat stores

The energy supplied by the sun cannot be influenced, and rarely matches the times when heat is required. Therefore the generated solar heat must be stored. It would be ideal if this heat could be saved from the summer to the winter (seasonal store) so that it could be used for heating. In some countries, such as Switzerland, this has already been done for several years in low-energy houses with hot water stores of several m³ in volume and collector surface areas of several tens of square metres. There are stores that store heat chemically, currently available as prototypes, which should be available on the market in the near future. Even for short-term storage over one or two days, to bridge over weather variations, developments are still taking place.

We differentiate heat stores according to the application, the compression strength and the material (Table 2.5).

Table 2.5.
Classification of solar stores

Type	Unvented	Vented
Secondary water	Stainless steel Enamelled steel Copper Plastic-coated steel	Copper Stainless steel
Buffer	Steel	Plastic
Thermal with domestic hot water	Steel/stainless steel Steel/enamelled steel	

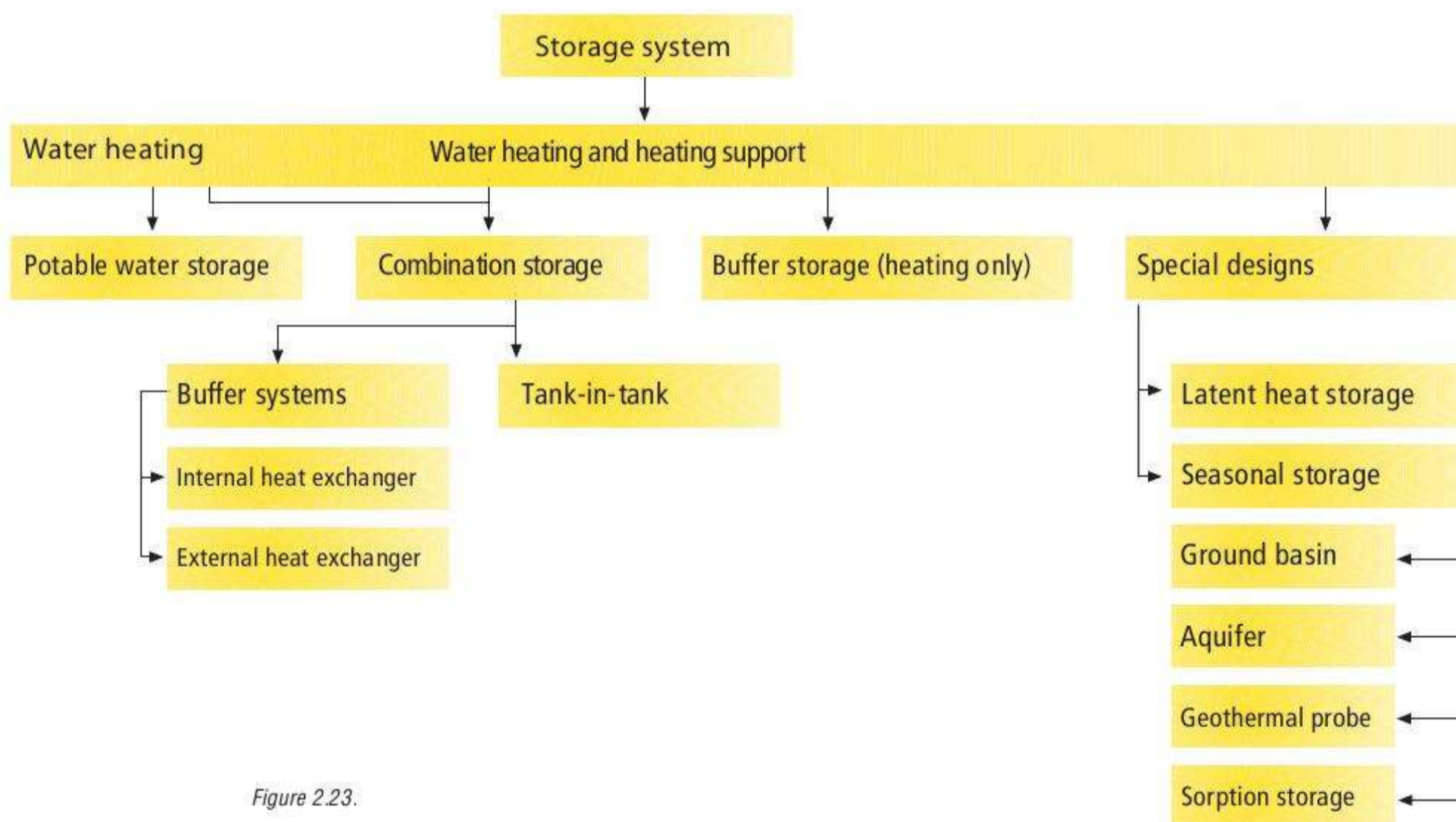

Figure 2.23.

2.3.1 Storage materials

Unvented tanks are offered in stainless steel, enamelled or plastic-coated steel or copper. Stainless steel tanks are comparatively light and maintenance-free, but significantly more expensive than enamelled steel tanks. Also, stainless steel is more sensitive to water with a high chloride content. Enamelled tanks must be equipped with a magnesium or external galvanic anode for corrosion protection reasons (voids or hairline cracks in the enamel). Cheaper plastic-coated steel tanks are also offered. Their coating must be free of pores, and they are sensitive to temperatures above 80°C (176°F). Vented plastic tanks are similarly sensitive to higher temperatures. In the UK, the predominant material used for tanks is copper. The advantages of copper are its lightness and the ease of fabricating it in different sizes.

2.3.2 Domestic hot water stores

Figure 2.24 shows an example of an unvented solar store, as often used in temperate climates. It has the following features:

- two heat exchangers for two heat sources (bivalent): a solar heat exchanger and an additional heat exchanger for a heating boiler
- direct connection to the cold water supply
- pressure tank 4–6 bar (58–87 psi) operating pressure.

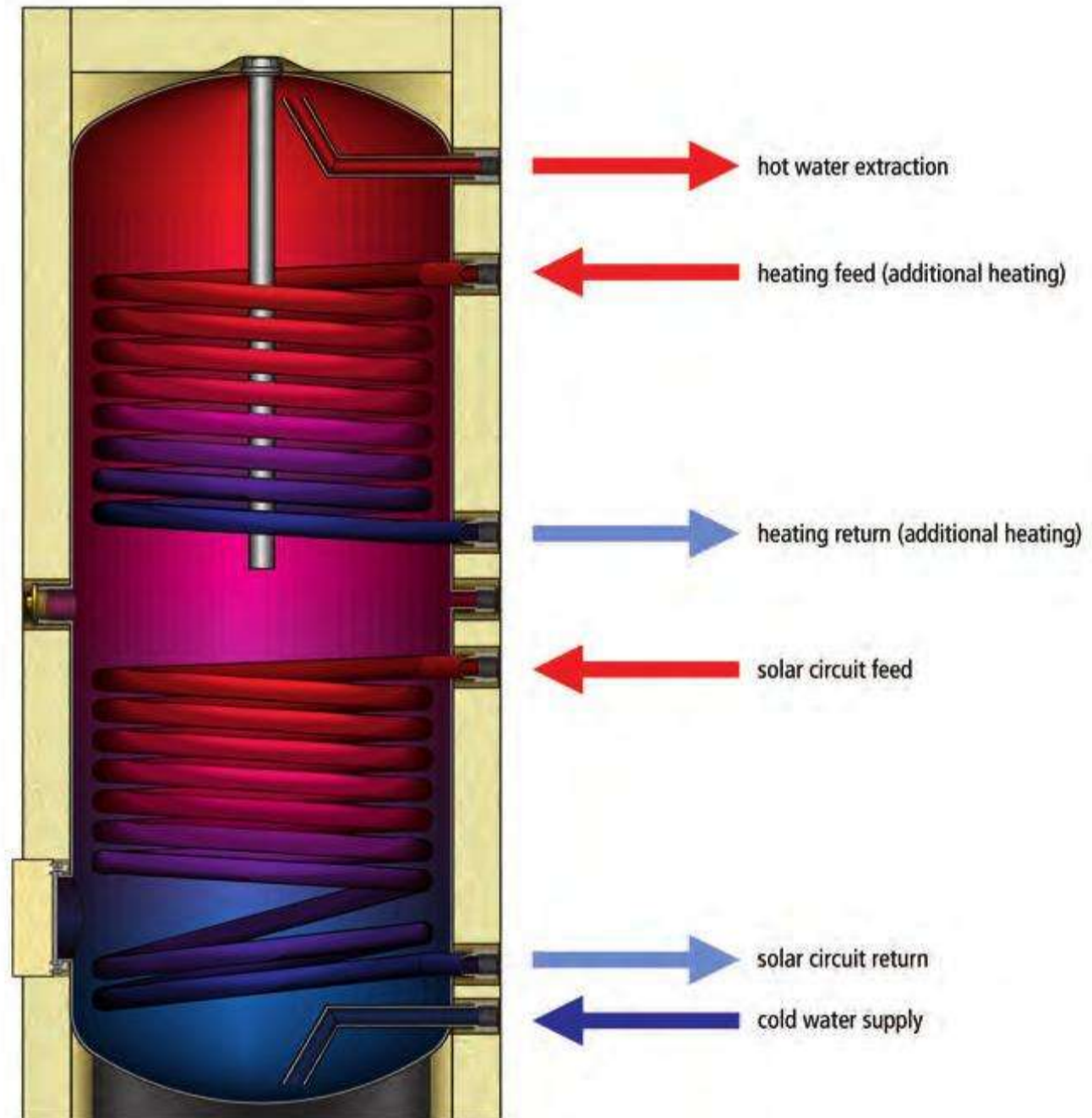

Figure 2.24.
Upright model solar tank with auxiliary
heat exchanger

Examples of typical store volumes are:

- UK: 150–200 l (39.6–52.8 gallons)
- Germany: 300–500 l (79.3–132.1 gallons) in the one- and two-family home segment of the market
- USA: 50–100 gallons (approx 200–400 l)
- Australia: 300–400 l (79.3–105.7 gallons) for 3–4 persons.

See also Chapter 3, section 3.5.2.4. Larger stores can take up greater quantities of energy, but for constant collector surface areas can lead to increased switch-on frequencies of the heating boiler when the store is not stratified because the temperature level in the tank is lower than for a smaller tank.

When the store contains water for consumption, one should be wary of limescale precipitation at temperatures above 60°C (140°F), which can block the heat exchanger surface (see section 2.3.5). Moreover, lime residues are deposited gradually on the base of the store.

There are various design features that have a significant impact on the suitability of a solar heat store. These are described below.

2.3.2.1 NARROWNESS OF THE HOT WATER STORE

Because of short-term variations in irradiation, the solar store should be able to contain the hot water consumption of about one to two days. Every time a tap is turned on, cold water flows into the lower area of the store, so that cold, warm and hot water are found in the one store at the same time. Because of the different densities, a

temperature stratification effect forms. The ‘lighter’ hot water collects at the top, the ‘heavier’ cold water in the lower tank area. This stratification effect has a positive effect on the efficiency of a solar system.

As soon as hot water is drawn off, cold water flows in: this should not mix with the hot water. The slimmer and taller the store, the more pronounced the temperature stratification will be. Upright stores have the best stratification; the recommended height–diameter ratio for optimum stratification is at least 2.5:1. The coldest possible lower zone ensures that, even with low irradiance, the solar system can still operate with high efficiency at a low temperature level (see Figure 2.25).

When installing slim stores, narrow doors seldom cause problems; there may however be problems with the overall height (the tilted dimension should be noted). What is important is the free height at the installation location, as heating pipes, water drainage pipes and similar frequently run below the roof.

Not all products follow the above reasoning. In many countries, solar water heaters are sold that use horizontal stores. These stores feature less stratification. Some such systems are sold with immersed electrical elements as backup heater. Such electrical elements are sensible only in hot climates where they are used for, at most, one or two months per year. In these systems the whole tank can heat up when the electrical element is activated, destroying the solar efficiency.

THE TEMPERATURE AND ENERGY CONTENTS OF A STORE

Let us consider a 300 l solar store in which, after charging and hot water consumption, the temperature layer system shown in Figure 2.25 has built up as a result of its slender construction. The energy content of this tank at a cold water temperature of 15°C is:

$$Q = mc_w \Delta\theta$$

where Q is the heat quantity (Wh), m is the mass (kg), c_w is the specific heat capacity of water = 1.16 Wh/kgK, and $\Delta\theta$ is the temperature difference (K).

$$Q = 100 \text{ kg} \times 1.16 \text{ Wh/kgK} \times 0 \text{ K} + 100 \text{ kg} \times 1.16 \text{ kWh/kgK} \times 15 \text{ K} + 100 \text{ kg} \times 1.16 \text{ Wh/kgK} \times 45 \text{ K} = 6960 \text{ Wh}$$

If the same energy content is charged into a store that cannot form layers there will be a uniform mixed temperature of:

$$\theta_m = \frac{6960 \text{ Wh}}{300 \text{ kg} \times 1.16 \text{ Wh/kgK}} + 15^\circ\text{C} = 35^\circ\text{C}$$

In this case additional heating is required in the standby area of the store (Figure 2.26); however, in the first instance 100 l of 60°C or 150 l of 45°C water can be drawn off. The calculation of the mixed temperatures is possible using the following equation:

$$\theta_m = \frac{m_1\theta_1 + m_2\theta_2}{m_1 + m_2}$$

Figure 2.25 (left). Usable stratification

Figure 2.26 (right). Additional heating required



2.3.2.2 BAFFLE PLATE AT COLD WATER INPUT

When a tap is opened, cold water will flow into the tank. To prevent mixing between the cold water and the warm water still in the tank, a baffle plate is often used.

2.3.2.3 HOT WATER EXTRACTION

With conventional unvented stores, the hot water is often taken out from the top. After the water has been taken out, the warm water standing in the pipes cools down again. The cooled water falls down into the upper layers of the tank (single tube circulation). This causes destruction of the stratification effect, and heat losses in the order of magnitude of up to 15% of the total store losses (Figure 2.27). A better system is one in which the pipe for the hot water outlet is led inside the store from the top to the bottom through a bottom flange or outside the store downwards within the heat insulation. In this way heat losses via the disturbed heat insulation in the hottest zone are avoided. At the very least the hot water outflow – if it is led to the side through the heat insulation – should be provided with a 180° pipe bend (syphon).

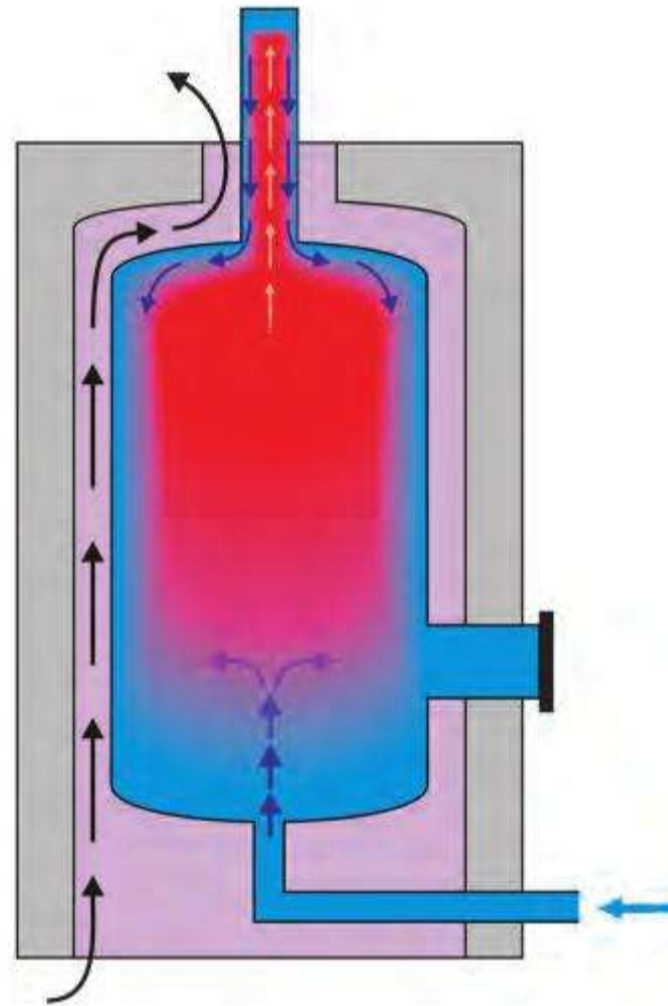

Figure 2.27.
Avoidable heat losses through design deficiencies⁹

2.3.2.4 HEAT EXCHANGERS AND THEIR CONNECTIONS

Ideally the heat exchanger connections for the solar and additional heating circuit should both be installed with two 180° pipe bends so that heat losses via the connections are reduced. The position of the additional heat exchanger in the upper area of the store guarantees rapid heating up of the standby volume (daily requirement), without removing the possibility of being able to store even small amounts of the sun's energy effectively in the cooler area of the store. The solar circuit heat exchanger should reach as far as possible down into the store, so that the tank's contents can be heated right down to the base of the tank.

2.3.2.5 INSULATION OF THE STORE

Good heat insulation is essential for an efficient solar store, and this includes the floor of the tank. It should fit well all round (otherwise there would be losses through convection), and consist of CFC- and PVC-free materials (melamine resin foam and polyethylene (PE) jacket, for example), with a thermal conductivity, $\lambda < 0.035$ W/mK. As for a collector, a k -value (W/m²K) can also be defined for a store as the ratio of the thermal conductivity to insulation thickness ($k = \lambda/D$). The product of the k -value with the store surface area, A , gives the heat loss rate, kA (W/K), of the tank.

In total, the heat loss rate should be less than 2 W/K. A very good store with a heat loss rate of, say, 1.5 W/K rather than 3 W/K, at a temperature difference of 35 K loses about 450 kWh less energy per annum. This corresponds to an additional collector surface area of about 0.5–1 m² (5.4–10.8 ft²) or additional costs of €200–400 (\$200–400, or £140–280).

The following insulation options are offered on the solar market: flexible foam; rigid foam envelope, which can be retrofitted; or in-situ foam-treated stores with plastic or metal jacket. It is particularly important to ensure that the insulation is closed tightly round the pipe connections without any gaps, and that flanges, plugs etc. are also insulated.

2.3.2.6 STORE TEMPERATURE SENSOR: SOLAR CIRCUIT

This sensor should always be fitted in the lower third area of the store, in the middle of the solar circuit heat exchanger, because in this way automatic switching of the pump takes place earlier than if the sensor is fitted higher. This means that, even where small amounts are drawn off, the system has the chance of recharging with solar energy. If no submerged sleeve is available at the corresponding height on the store, a contact sensor can also be used. This causes no problems if a clamping block for the sensor is provided (outside the store, passing from the top to the bottom). The height can be selected in this case within certain limits. If no sensor-clamping block is provided there may be fixing problems. As it is important to have good thermal contacts for control of the system (firm seating and heat conducting paste), poor thermal contact may lead to malfunctioning of the complete system.

2.3.2.7 STORE TEMPERATURE SENSOR: ADDITIONAL HEATING

If an auxiliary heating source is connected to keep the upper part of the store at a set temperature, this sensor provides the information for the control of the additional heating and signals the information for the beginning and end of the auxiliary heating process. It should be fitted at the same height as the auxiliary heat exchanger, or higher, but never below it. It is part of the boiler controller.

2.3.3 Buffer store

Buffer stores (or thermal stores) can be vented or unvented and filled with heating water. The heat stored in them can be either directly fed into the heating system (heating support) or transferred via a heat exchanger to the domestic hot water. Buffer storage is nothing new for plumbers. Buffer storage is used to avoid the cycling of heating boilers: the boiler first charges the store, which leads to longer burner running times (longer service life, lower hazardous substance emissions). The radiators are then supplied from the store.

2.3.4 Combination stores

Combination stores can feed the produced heat directly into the heating system (back-up heating) or alternatively deliver it to the domestic water system by means of an internal or external heat exchanger. Combination stores are available as a Tank-in-Tank store or predominantly as a buffer store with temperature stratification and an internal or external discharge heat exchanger (layer storage).

2.3.4.1 STORAGE BOILER COMBINATION/COMBINATION STORAGE BOILER

There are several manufacturers who offer a buffer storage tank with an integrated gas, oil or pellet burner (Solvis, Rotex, Solarfocus, Pro Solar, ELCO GmbH, Atmos Heating Systems, Eco-Hometech). Relatively new on the market are storage systems with a flanged or integrated heat pump (Solvis).

SOLVIMAX

The SolvisMax unites a solar-layered storage tank (as a buffer tank) and a gas or oil-condensing boiler in one device. In connection with solar heat collectors a complete solar heating system is developed, responsible for space heating and hot water. Whether used as pure boilers or as storage tanks with solar heat collectors, the modules can be combined in a flexible way, all together or successively. Heat can be transferred into the store in a variety of ways – even by means of a fireplace, a wood stove or combined heat and power plant. The latest development is the integration of a heat pump. Solvis operates at present on an integrated pellet burner and plans to combine this with a fuel cell.

The system's core element is the solar-layered store. The solar heat is stored in layers of the same temperature and is thus used efficiently. The main part of energy

saving entails the integration of the burner directly into the store. The all-purpose controller/universal regulator manages the entire system. The boiler is available at three performance ranges of 5–20 kW, 7–25 kW and 8–30 kW. The connection of the heating circuits takes place in series over a heating circuit station with a high-efficiency pump of energy efficiency class A.

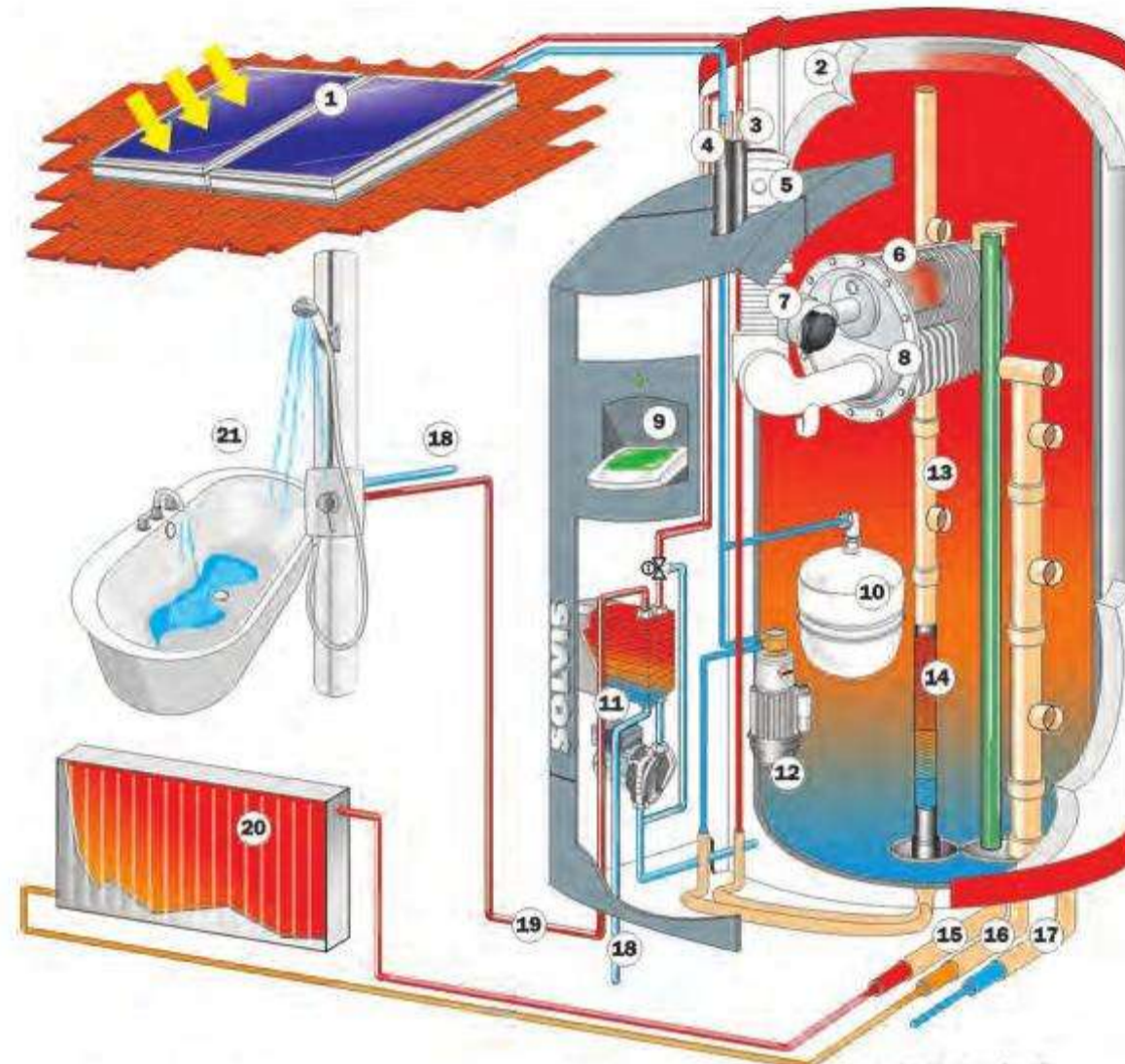

- | | | |
|------------------------------|-------------------------------------|-----------------------------|
| 1 Solvis solar collectors | 8 Exhaust heat exchanger | 15 Heating feed |
| 2 Insulation | 9 System controller SolvisControl 2 | 16 Heating return |
| 3 Solar feed | 10 Solar expansion vessel | 17 Supply and drainage pipe |
| 4 Solar return | 11 Hot water station | 18 cold water |
| 5 Exhaust pipe connection | 12 Solar pump | 19 Hot water |
| 6 Gas/oil combustion chamber | 13 Stratified charger | 20 Heating |
| 7 Gas/oil burner | 14 Solar heat exchanger | 21 Hot water outlet |

Figure 2.28.
Section through the Energy Manager
'SolvisMax' (Manufacturer: Solvis GmbH
& Co. KG, Braunschweig)

SOLVIMAX HEAT PUMP

Solvis's latest development combines a stratified store, heat pump and solar heat collector into one system. The heat pump is integrated into the store. The combination of geothermal heat with solar heat lowers operating costs considerably, and further energy savings are achieved by using circulation pumps of energy efficiency class A.

The system with heat pump is an economic solution for low-energy buildings with a heating demand of up to 6 kW. It has low maintenance costs and requires little space, as – compared with oil or pellet heaters – no fuel stocks are needed.

The condenser is a fin tube heat exchanger. A heating loop in the upper store area ensures that the supplied heat can be used directly for hot water production. Likewise it is possible and unproblematic in the summer to cool the building with geothermal heat, ground floor or wall heating. Combination with a wood stove or fireplace is also feasible, so that larger heat requirements, depending upon user behaviour and size of the wood stove/furnace, can be realized – up to 12 kW in a CO₂-neutral manner.

XENON

The solar combination system Xenon 24 consists of two modules arranged one above the other. The lower module is an indirectly heated hot water store made of copper (100 litre capacity), which is connected with the upper module. The upper module consists of a modulating gas condensing boiler (0–22 kW) that is embedded in a hot water store with an 80 litre capacity. The device is designed for the hot water and heat demands of a single family house.

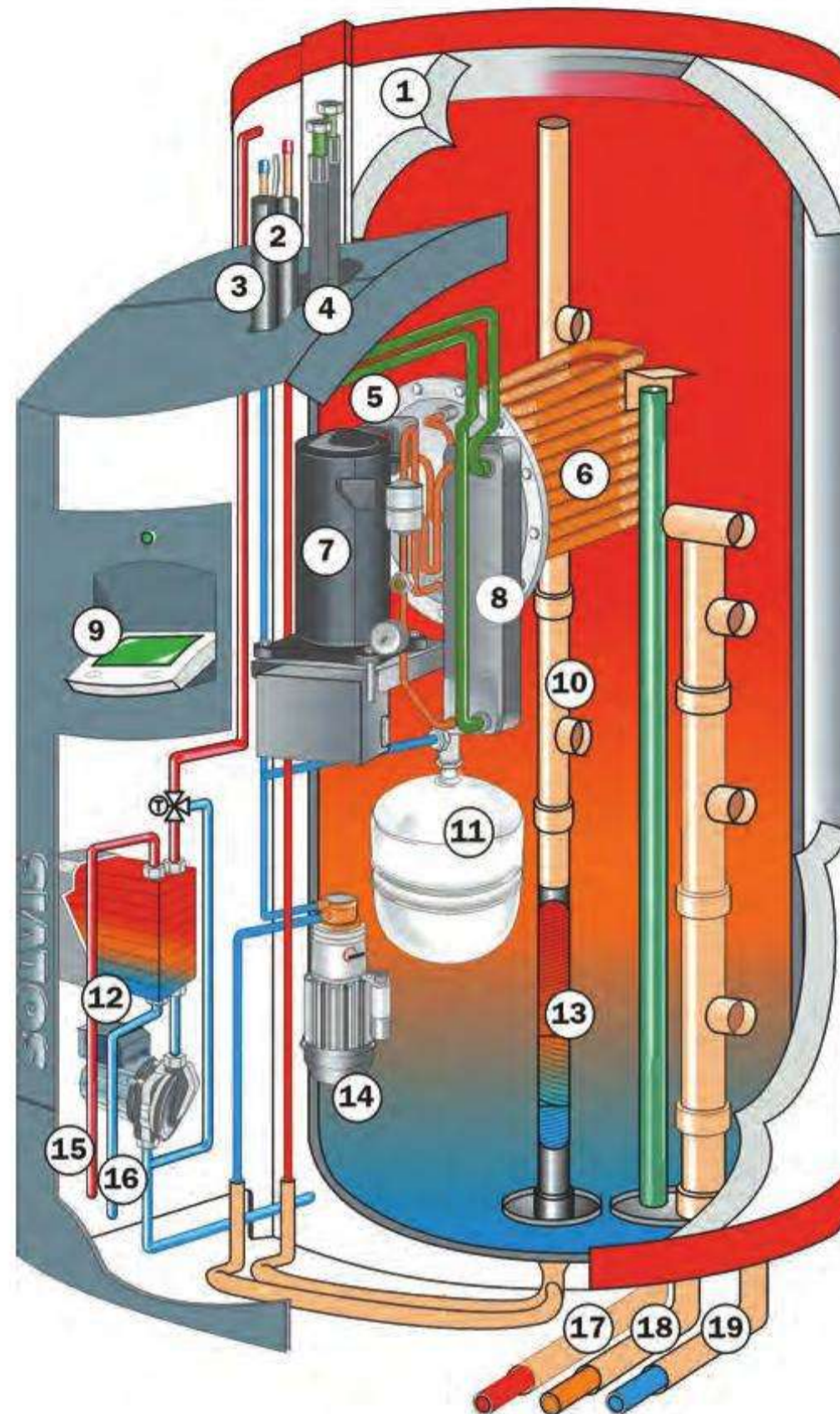

Figure 2.29.
Section through 'SolvisMax' energy manager with heat pump (Manufacturer: Solvis GmbH & Co. KG, Braunschweig)

- | | | |
|-----------------------------|-----------------------------------|------------------------------|
| 1 Insulation | 8 Evaporator | 16 Cold water |
| 2 Solar flow | 9 SolvisControl system controller | 17 Heating flow |
| 3 Solar return | 10 Stratified charger | 18 Heating return |
| 4 Brine inflow and backflow | 11 Solar expansion vessel | 19 Filling and draining pipe |
| 5 Electric heating rod | 12 Hot heat exchanger | |
| 6 Condenser and boiler | 14 Solar pump | |
| 7 Compressor | 15 Hot water | |

GAS SOLAR UNIT

The ROTEX gas solar unit is a gas-condensing boiler, which is inserted into the upper part of an unpressurized 500-litre plastic storage tank. There is also a plastic tube heat exchanger for hot water generation according to the flow principal.

PELLET PLUS

With the pellet-burner/layered-storage-tank combination developed by Kalkgruber, the pellet burner is flanged on to the storage tank. The burner operates modulating in the performance range of 4.4–19 kW.

LATENT HEAT AND THERMO CHEMICAL STORAGE UNIT

Besides the conventional solar storages, which store 'sensible' heat in the medium of water, other storage technologies aim for a higher energy density*) in order to bridge a longer time period. In particular solar heating systems rely on long-term storages with higher usable energy densities than that of water (approx. 50 kWh/m³), in order to reduce the high volume of contemporary storage tanks, which are needed to cover higher use fractions.

* higher amount of energy per volume

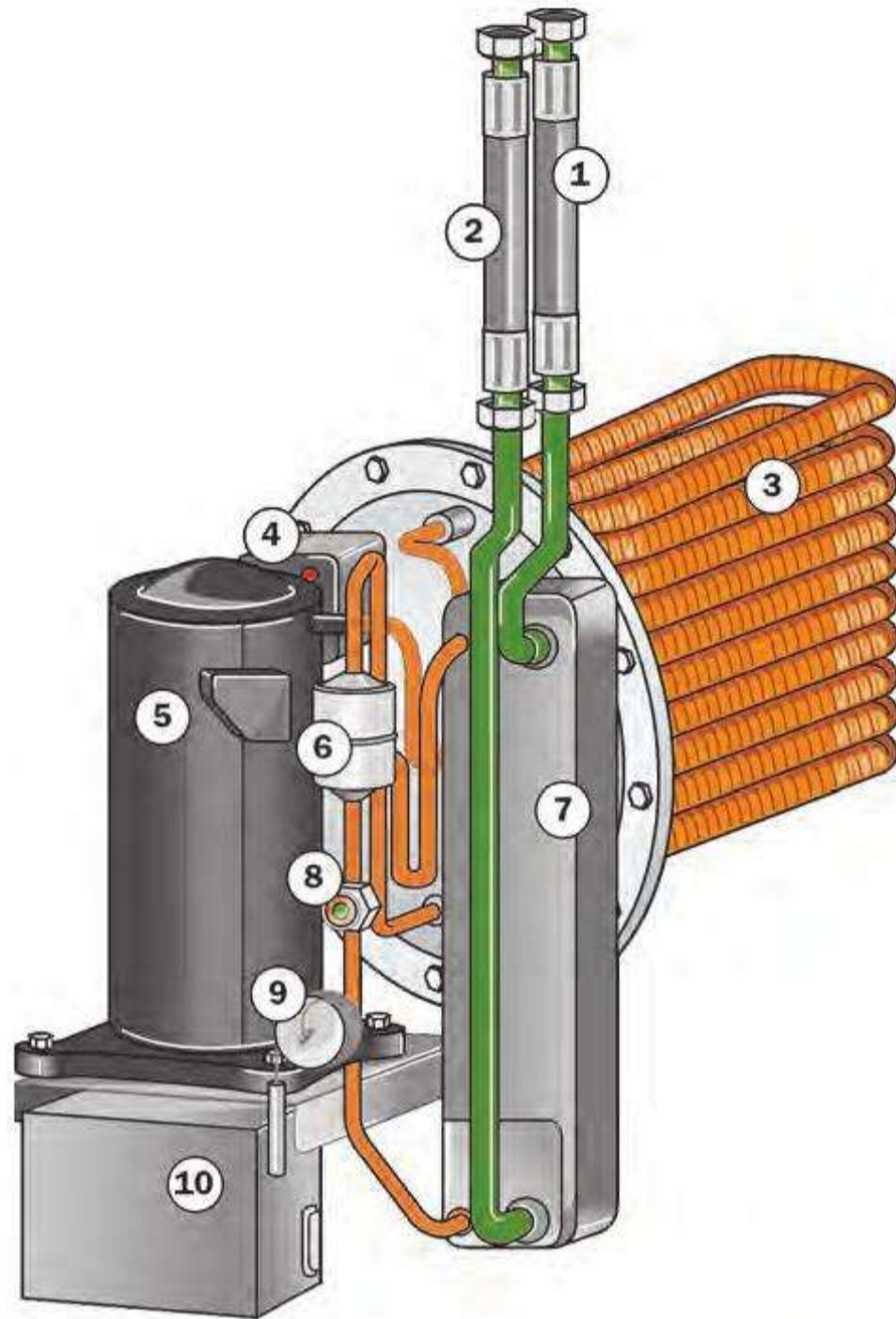

- | | | |
|------------------------|------------------------|-------------------|
| 1 Brine return | 4 Electric heating rod | 8 Sight glass |
| 2 Brine flow | 5 Compressor | 9 Expansion valve |
| 3 Condenser and boiler | 6 Filter dryer | 10 Junction box |
| | 7 Evaporator | |

Figure 2.30.
SolvisMax Heat Pump
(Solvis GmbH & Co. KG, Braunschweig)



Figure 2.31.
XENON 24
(Manufacturer: ELCO GmbH,
Mörfelden-Walldorf)

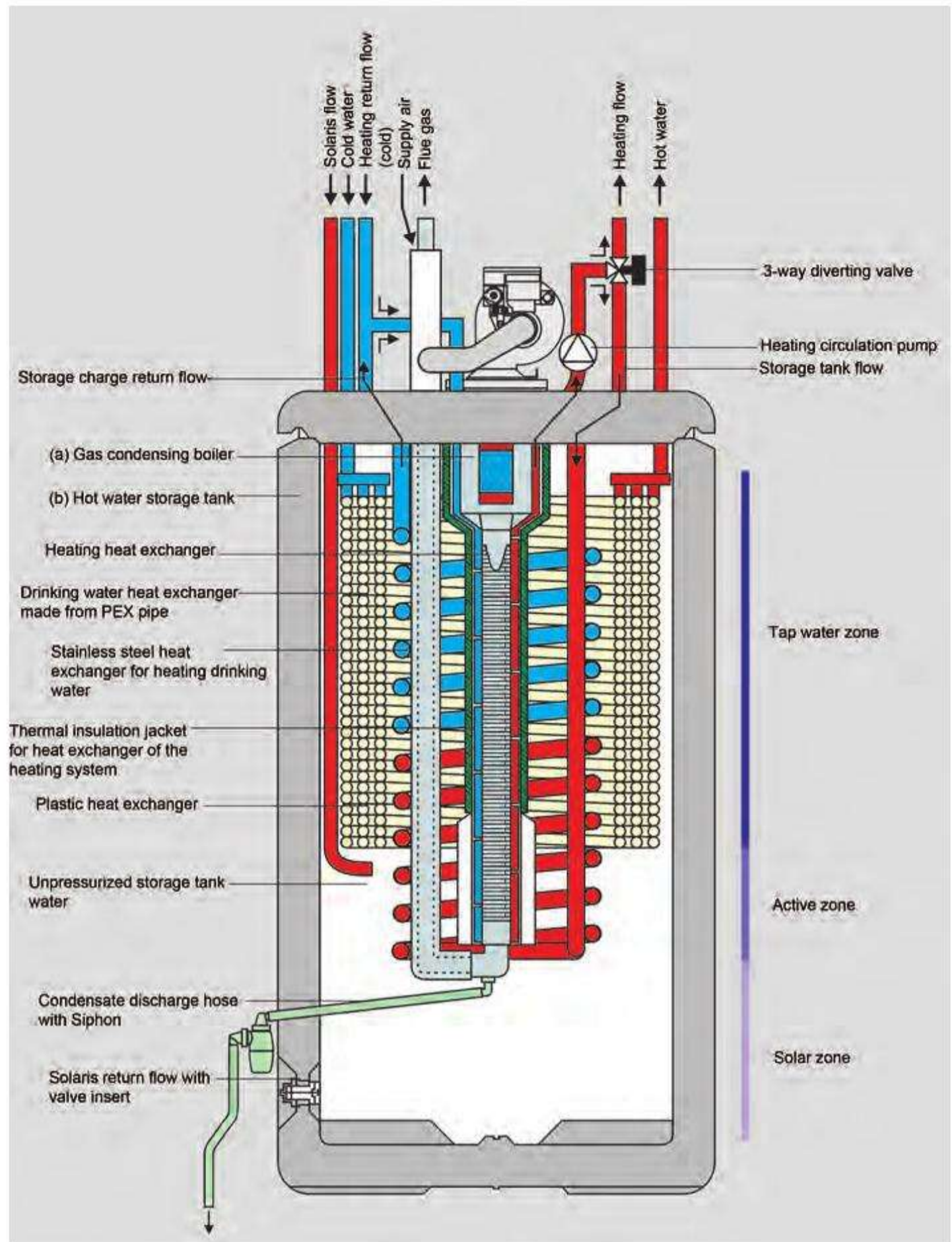

Figure 2.32.
GasSolarUnit from Rotex (Manufacturer:
Rotex, Gussglingen)

In principle, there are three possibilities to store heat:

- 1 Heat storage by means of direct heat supply in insulated, water filled tanks;
- 2 Latent heat storage, which applies the solid–fluid phase transition of salt hydrates or paraffins;
- 3 Thermo chemical storage units (sorption tanks) with which supply of heat splits a compound into its properties, and later with the recombination of the components frees that heat again.

Whilst latent heat storages, using the energy of phase transition, are by now available on the market (Rubitherm, Schneider, Latento, Cerit, Powertank), research in the field of thermo chemical storage units continues.

Thermo chemical heat storage differs from the first two storage principles. Heat storage is based on the reversible chemical reaction according to the formula



During the load phase, the substance AB is supplied with heat, which dissociates the components A and B. In order to recover the heat, both components A and B are allowed to react with one other. As long as a reaction between A and B is prevented, the heat stored in form of chemical energy cannot be set free. This way, heat can be stored at various temperature levels over a period of time. In Figure 2.34, A corresponds to dry silica gel, B corresponds to free water vapour and AB to the water saturated silica gel.

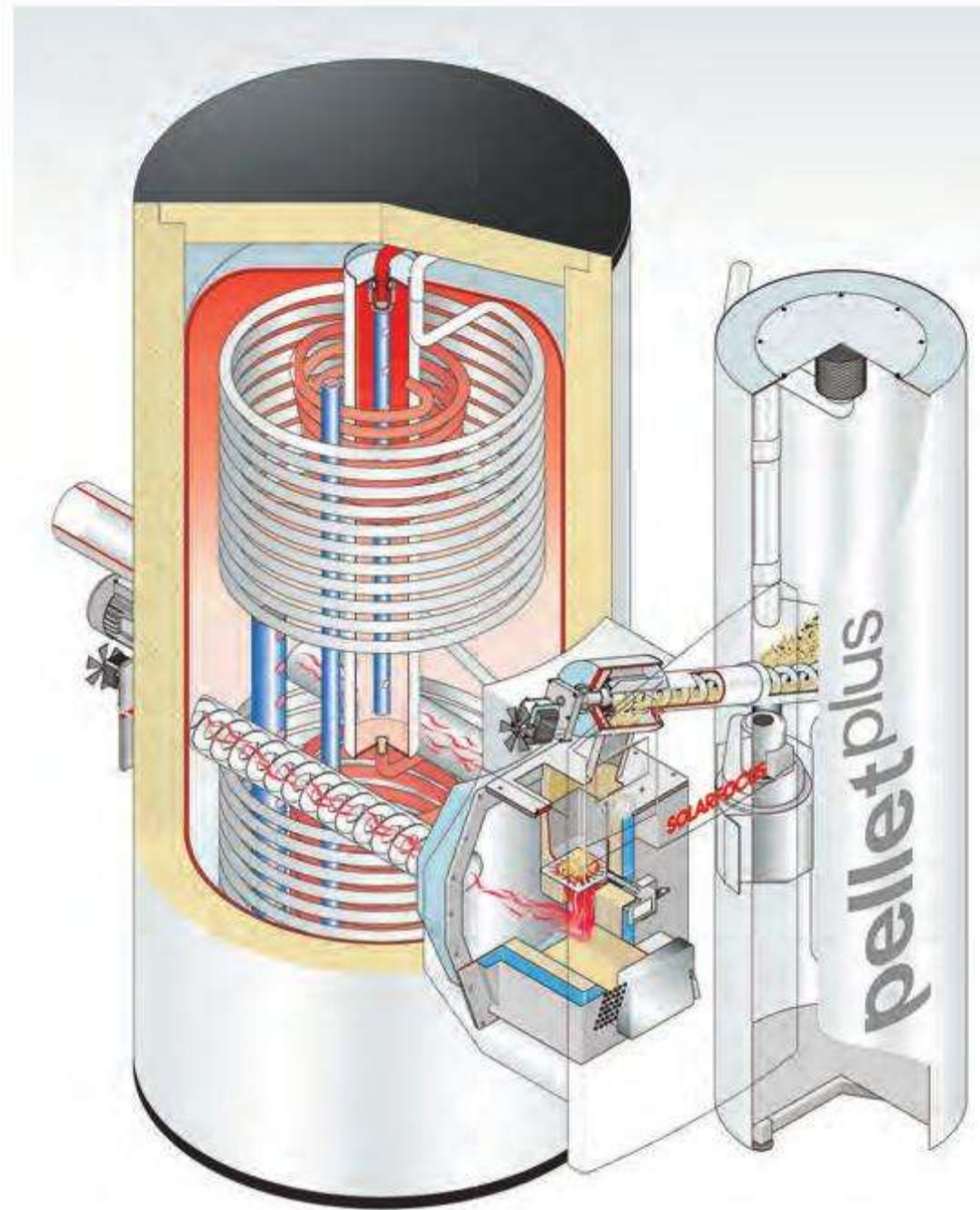

Figure 2.33.
(Manufacturer: Solarfocus GmbH, St. Ulrich/Steyr, Austria)

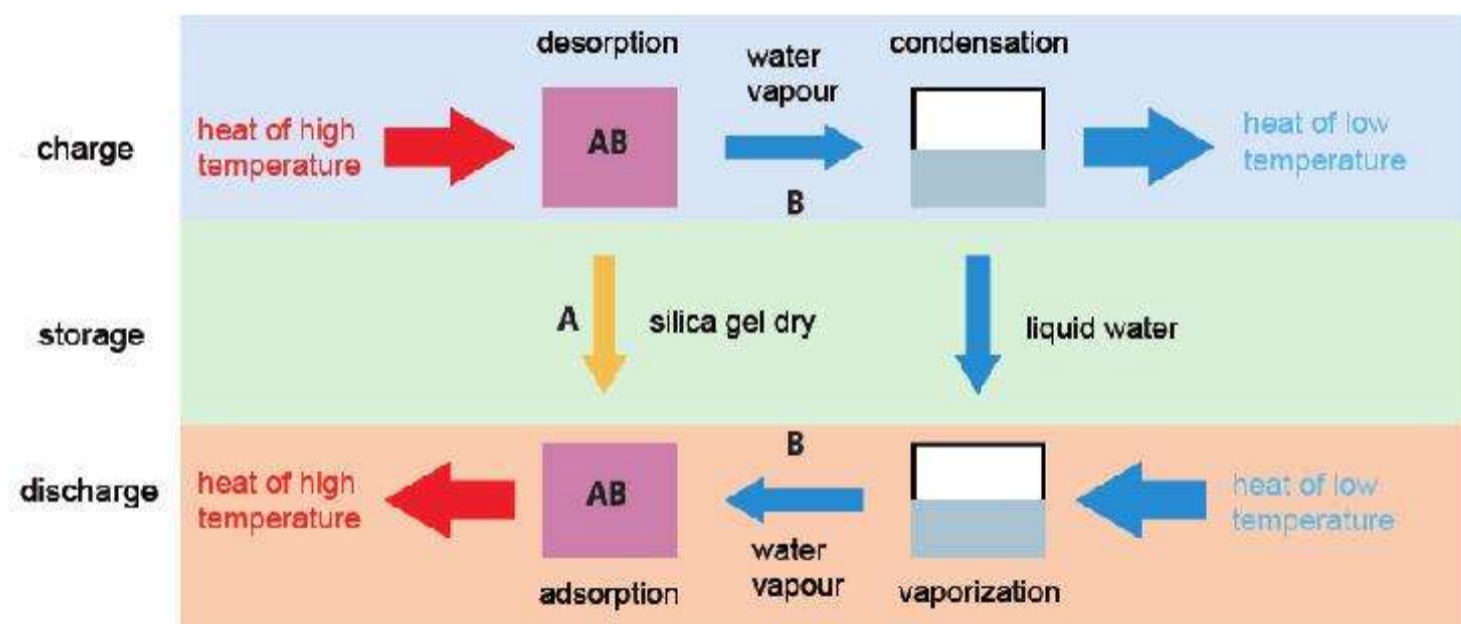

Figure 2.34.
Basic principle of thermo chemical storage

For the long-term storage of solar heat, the adsorption of water vapour in the pores of silica gel was examined in the context of a research project promoted by the European Commission (Fraunhofer ISE, UFE SOLAR GmbH and the spun off/outourced SorTech AG, GRACE GmbH and partners from Austria and Finland). The results of the tests with prototypes can be summarized as follows:

- The process engineering functions (heat and mass transfer, vacuum tightness) could be essentially solved.
- In practice, a maximum energy density of approx. 125 kWh/m³ was achieved for inlet temperatures for a wall heating system of 32 to 35°C (90–95°F).
- By straightforward improvements of the technical construction of the absorber and the operating control, an energy density of 135 to 140 kWh/m³ was achieved.
- Further improvements to the energy density are only realizable through modifications of the base material silica gel.

CONCLUSION

Threefold energy density

The (at present) maximum attainable energy density of approximately 150 kWh/m³ still leads to a large storage volume for solar space heating. The advantage of the threefold energy density compared to a water store is not sufficient to justify the clearly higher expenditure in process engineering. For this reason progress in the material development is a prerequisite for a commercial application of sorption storages in solar space heating systems.

2.3.5 The thermostatic mixing valve

The thermostatic mixing (blending) valve controls and limits the temperature of the hot water. If the hot water taken from the solar store is too hot, the thermostatic mixing valve mixes cold water into it. Independently of the design and temperature of the water heater, it ensures a constant temperature at the withdrawal point and therefore protects the users from scalding. European standard EN 12976-1 states that a thermostatic mixing valve should be installed if the domestic hot water temperature can reach over 60°C (140°F) in the hot water system. In the case of domestic hot water stores this occurs if the store tank temperature has not been already limited to 60°C (140°F) in order to reduce lime formation.

A thermostatic mixing valve must be installed immediately at the hot water outlet of the solar store (without blocking safety vents). Most models can be set variably to temperatures between 30°C (86°F) and 70°C (158°F) (up to 10 bar (145 psi)). There must be a filter in the cold water pipe to protect the mixer from contamination and hence to avoid malfunctions.

2.3.6 Connection of washing machines and dishwashers

Washing machines and dishwashers require the largest part of their power consumption for heating the water. The connection of a solar system offers the opportunity of replacing expensive electrical power with the sun's energy, and the opportunity of increasing the efficiency of the system.

In several European countries *hot fill* dishwashers and washing machines are on the market, which are suitable for connecting to the hot water pipe system. These can be directly connected to the solar system to make immediate use of the sun's energy.

Most washing machines do not have a hot water connection; for these machines special control units are available in many countries that can regulate the cold and hot water flows to the machine according to the desired washing programme.

2.3.7 Legionella contamination

After several severe outbreaks of Legionella (including an outbreak in the Netherlands, where, in 1999, 29 people died after a Legionella infection caused by an infected whirlpool at a demonstration during a flower exhibition), strict legal requirements were developed for official public buildings in several countries including the Netherlands and Germany. These requirements can significantly affect the design of solar water heaters. For instance, in the Netherlands there is a duty on the building owner to keep a log book (with information on, for example, prevention measures taken, temperature measurements taken, and planned modifications to the installation etc.). Within the scope of the prevention measures, the cold water temperature must never exceed 25°C (77°F) and the hot water temperature must never fall below 60°C (140°F). This means that all solar water heaters must have an auxiliary heater always on and set to at least 60°C (140°F).¹⁰ In Germany, strict requirements are put on hot water installations with a volume exceeding 400 l (106 gallons), which has caused many solar water heaters to be designed in such a way (often using tank-in-tank constructions) that this volume is not reached.

At present, methods such as pasteurization are being tested in practice in order to overcome these problems. To what extent these will be implemented or specified at the European level, with a harmonized procedure, remains to be seen.

LEGIONELLA

Legionella pneumophila, a rod-shaped bacterium, is naturally found in water. The concentration of Legionella bacteria is very low in cold natural water, and hence normally there is no danger to health. Legionella bacteria multiply most quickly at temperatures between 30°C (86°F) and 45°C (113°F). They are destroyed at temperatures above 50°C (122°F), and this process is significantly accelerated with increasing temperatures.

Crucial factors for the risk of an infection are:

- *The way the bacteria are absorbed.* As long as they are absorbed via the gastro-intestinal tract – that is, if water is swallowed during swimming or when cleaning teeth – they are harmless. A danger of infection occurs only if they enter the lungs, for example by inhaling finely dispersed water droplets in the air (aerosol), such as during showering.
- *The concentration of bacteria.* Legionella can occur in dangerous concentrations in air-conditioning plants with air humidifiers, in whirlpools, and in large hot water systems where hot water stands for long times, such as in hotels or hospitals with large stores and long pipelines.
- *The time span spent in a contaminated environment.*
- *Personal resistance to illness.*

2.4 Solar circuit

The heat generated in the collector is transported to the solar store by means of the solar circuit. This consists of the following elements:

- the pipelines, which connect the collectors on the roof and the stores
- the solar liquid or transport medium, which transports the heat from the collector to the store
- the solar pump, which circulates the solar liquid in the solar circuit (thermosyphon and ICS systems do not have a pump)
- the solar circuit heat exchanger, which transfers the heat gained to the domestic hot water in the store
- the fittings and equipment for filling, emptying and bleeding
- the safety equipment. The expansion vessel and safety valve protect the system from damage (leakage) by volume expansion or high pressures.

2.4.1 Pipelines

Copper is the most frequently used material for the heat transport pipelines between collector and store. Many types of fittings made of copper, red bronze or brass are available for Cu/Cu connections and the transitions to other system components with threaded connections. If the installation conditions are restricted in the area of the collector connections, or in the case of self-assembly, flexible stainless steel corrugated pipes are used (this means solder-free pipe connections). Steel pipes are also often used, mostly for larger systems. Using galvanized pipes together with antifreeze fluids is not recommended, as this leads to corrosion problems.

INSULATION OF PIPELINES

In conventional heat installations, insufficient attention is often given to the insulation. But what is the use of the best heating technology if a large and unnecessary amount of heat is lost on the transport routes and in the store?

According to European Standard EN 12976 (see Appendix B), for pipes up to 22 mm (0.87 inches) external diameter the thickness of the layer of insulation should be at least 20 ± 2 mm (0.8 ± 0.08 inches). For pipes with external diameters between 28 and 42 mm (1.1 and 1.7 inches), the insulation thickness should be 30 ± 2 mm (1.2 ± 0.9 inches). The insulation material used should have a thermal conductivity of $\lambda \leq 0.035$ W/mK.

It is important to insulate the complete piping without gaps and open spots. That means that even the fittings, valves, store connections, plugs, flanges and similar must be well insulated. In the solar circuit a temperature-resistant insulation material must be used, such as Aeroflex or Armaflex HT, up to 150–170°C (302–338°F) (see Figure 2.35). External pipelines must be UV and weather resistant as well as being waterproof, and should offer protection from animal damage, for example by installing them in a metal jacket.

Apart from the traditional separately installed combination of pipe, thermal insulation and electric cable, prefabricated pipeline units, consisting of copper pipe or corrugated hose of stainless steel including heat insulation and electric cable, are offered on the market from the roll for installation of the solar feed and return, and the collector sensor.



Figure 2.35.
Temperature-resistant thermal insulation
(Armstrong Insulation, Pfaffnau)

2.4.2 Solar liquid

The solar liquid transports the heat produced in the collector to the solar store. Water is the most suitable medium for this, as it has some very good properties:

- high thermal capacity
- high thermal conductivity
- low viscosity.

Moreover, water is:

- non-combustible
- non-toxic
- cheap.

As the operating temperatures in collectors can be between -15°C (5°F) and $+350^{\circ}\text{C}$ (662°F), if we use water as the heat transfer medium we shall have problems with both frost and evaporation.

In fact, water:

- freezes (at 0°C ; 32°F)
- evaporates (at 100°C ; 212°F).

Through the addition of 40% propylene glycol, which is predominantly used at present, frost protection down to -23°C (9.4°F) is achieved, together with an increase in the boiling point to 150°C (342°F) or more, according to the pressure.

Water is highly corrosive. This is further increased by the propylene glycol. For this reason a whole range of inhibitors are used, each inhibitor offering corrosion protection for a specific material.

Other effects of the addition of glycol are:

- reduced thermal capacity
- reduced thermal conductivity
- increased viscosity
- increased creep capacity.

Apart from a sufficiently high thermal capacity and conductivity, together with good frost and corrosion protection, another requirement for the solar liquid is its biological degradability. It must be non-toxic and non-irritant. All the requirements given are best fulfilled at present by a water-glycol mixture with liquid inhibitors.

In Figures 2.36–2.39 some characteristics of various concentrations of mixtures of water and propylene glycol are shown.

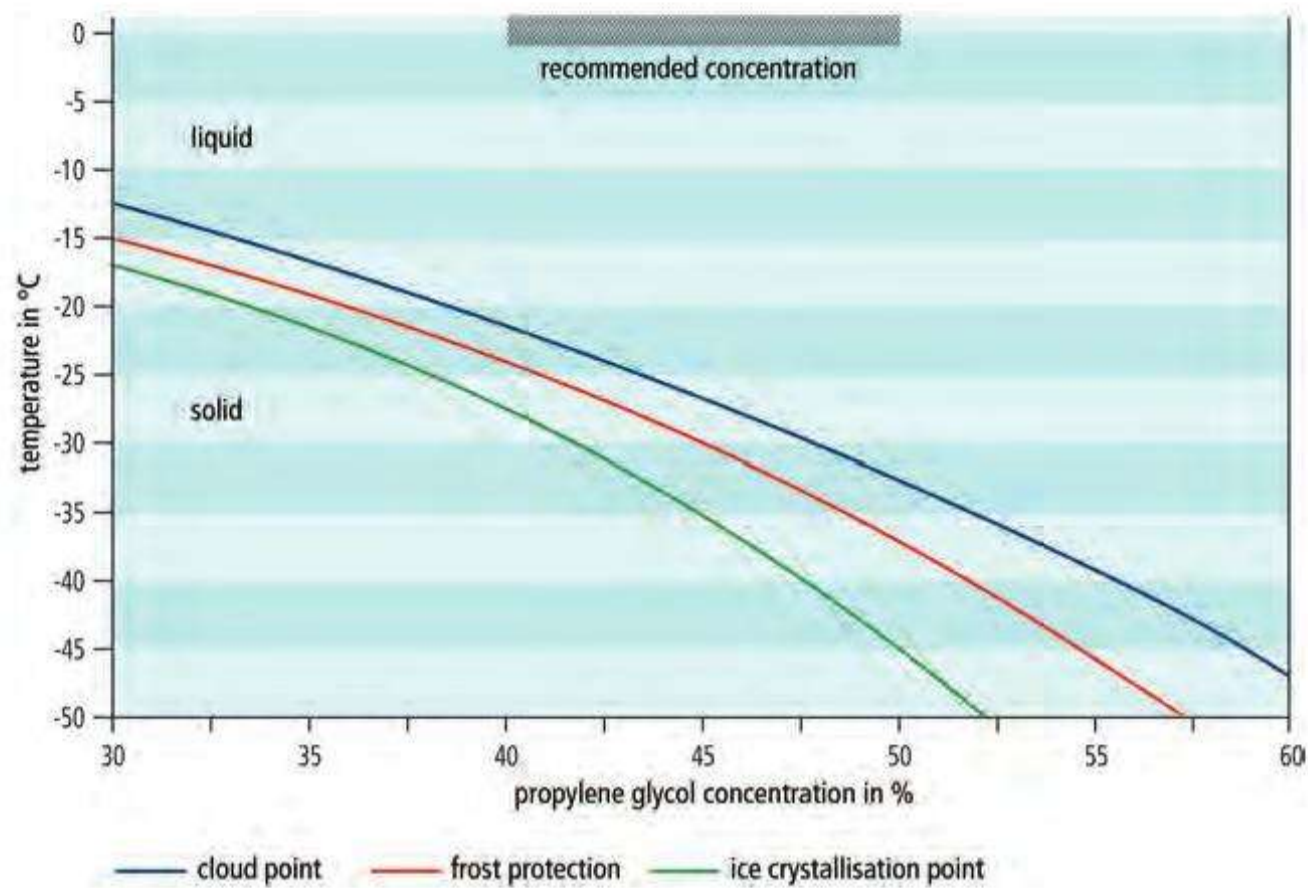

Figure 2.36. Frost protection from water/propylene glycol mixtures, as a function of concentration. The pour point temperatures are determined according to DIN 51 583, and the ice flocculation point temperatures to ASTM D 1177¹¹

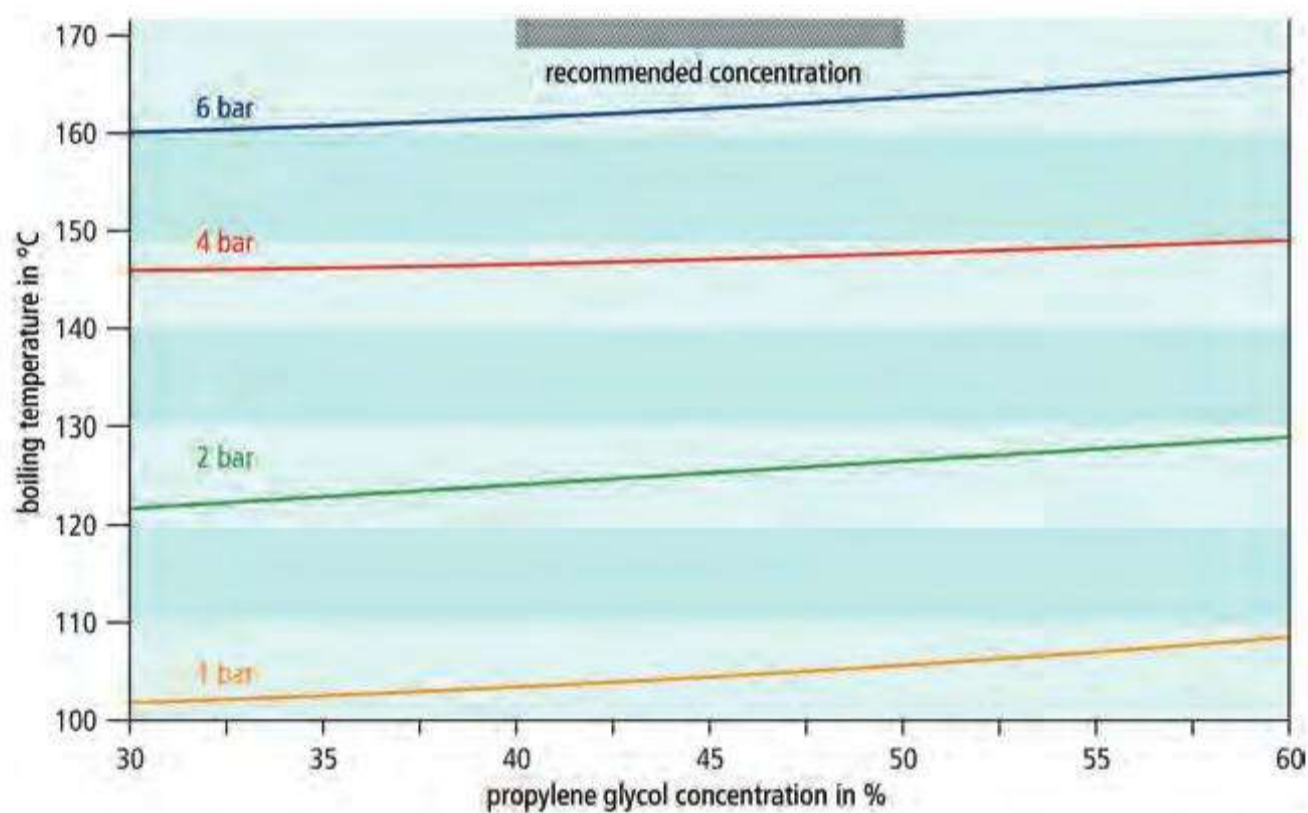

Figure 2.37. Boiling temperature in °C of water/propylene glycol mixtures as a function of operating pressure¹¹

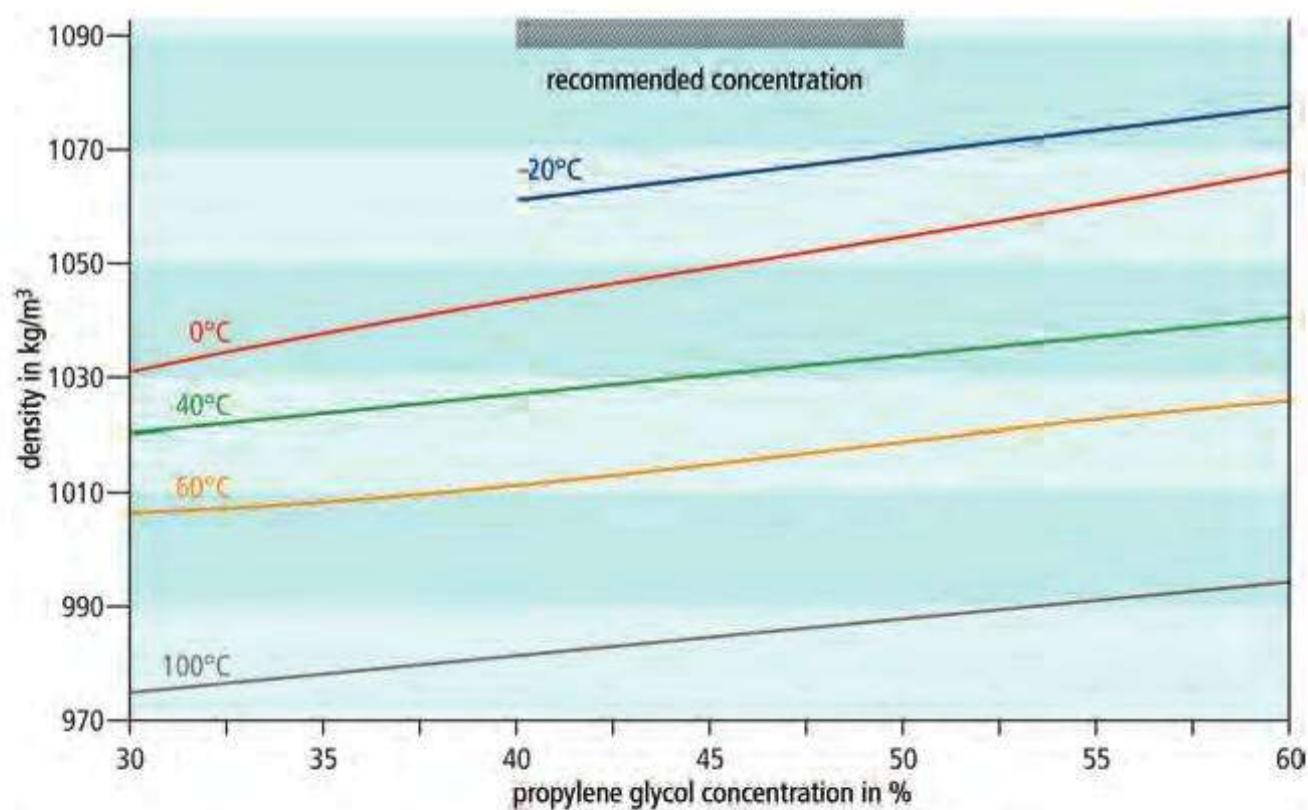

Figure 2.38. Density of water/propylene glycol mixtures as a function of temperature¹¹

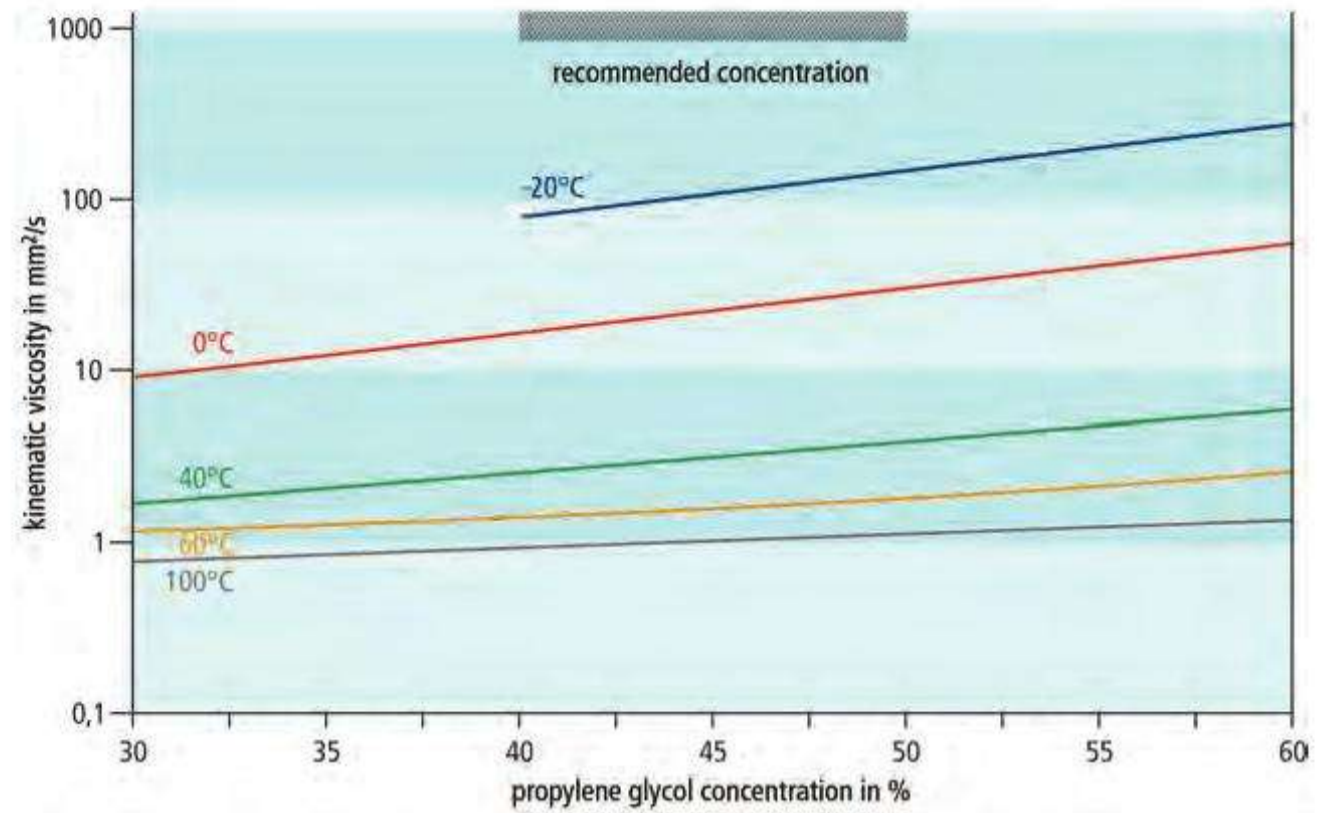

Figure 2.39.
Kinematic viscosity (in mm^2/s) of
water/propylene glycol mixtures as a
function of temperature¹¹

SOLAR LIQUIDS IN EVACUATED TUBE COLLECTORS

Stagnation temperatures of up to 350°C (662°F) in evacuated tube collectors demand excellent thermal stability of the heat transfer medium. At these temperatures, boiling of the liquid cannot be prevented. Heat transfer media are required that evaporate without leaving any residue.

Decisive factors in the corrosion of metal materials in solar energy systems by liquids are the oxygen content, the presence of dissolved solids, and their pH values. In order to reduce the significantly higher corrosive nature of mixtures with propylene glycol in comparison with water, inhibitors are added. These form a protective film on the metal surface. In the heat transfer media that are normally used for temperatures of up to 200°C (392°F), dissolved substances have been used. When the liquid evaporates, solid, non-vaporizable residues remain on the pipe walls, which in the most unfavourable case can no longer be taken up by the re-condensing liquid. Insufficient or lack of re-solubility in these coatings can lead to restrictions and even blockages in the flow channels over time, particularly for very small cross-sections such as the U-pipe in the Sydney collector.

By the use of new liquid inhibitors, the formation of this residue can be effectively prevented as, in the stagnation situation, the medium – that is, propylene glycol, water and inhibitors – evaporates and can re-condense.

2.4.3 Solar pumps

For pumped systems, the use of electricity for pumps should be kept as low as possible, and therefore over-dimensioning of the power of the pump should be avoided. For systems in one- and two-family homes an accurate calculation of the pressure losses in the solar circuit is not necessary if nominal widths for pipelines are selected according to Table 3.3 in Chapter 3. The pumps offered by system manufacturers within the framework of complete systems possess a suitable range of powers. Through the use of three to four switchable power settings, the volumetric flow can be selected so that, at the maximum performance of the collector (with high irradiance), a temperature difference of between 8 and 12 K is produced between the feed and return lines. This situation should occur at a medium power setting so that the performance of the pump can be increased or reduced as required. For large collector surface areas, however, a calculation of the pressure losses in the pipe network must be carried out in order to determine the pump capacity (see example calculation in Chapter 3, section 3.5.2.6)

Heating pumps are actually designed for a high volumetric flow with low delivery heights: that is, for other conditions than those that apply to solar energy systems. In fact they operate here with very low efficiencies of between 2% and 7%. Several specialised pumps are on the market that have been optimized for application in solar energy systems, with low power consumption and sufficient head.

2.4.4 Solar heat exchanger (heat transfer unit)

For the transfer of the heat gained from the sun to the domestic hot water, a heat exchanger (heat transfer unit) is required in twin-circuit systems. We can differentiate between *internal* and *external* heat exchangers.

2.4.4.1 INTERNAL HEAT EXCHANGERS

As internal heat exchangers, *finned tube* and *plain tube* types are available (Figure 2.40). The plain tube heat exchanger possesses a greater heat exchange capacity per square metre of exchanger face. Compared with the finned tube heat exchanger a multiple of the pipe length is required. Plain tube heat exchangers are installed in the factory, whereas finned tube heat exchangers, because of their more compact design, can be installed into the store on site by means of special flanges and seals. However, the effectiveness of heat exchangers can be reduced by the build-up of limescale. Even a layer 2 mm (0.08 inches) thick reduces the heat transfer capacity of a heat exchanger by 20%; a 5 mm (0.2 inch) thickness reduces it by more than 40%.



Figure 2.40.
Top: Finned tube heat exchanger
Bottom: Plain tube heat exchanger

The vertical installation of heat exchangers is more favourable, and should be preferred, because it promotes the stratification effect in the store system.

The connections to the solar circuit should be made so that the exchanger flow is from top to bottom, so that as much heat as possible can be transferred.

For thermosyphon systems, the proper circulation of the fluid inside the heat exchanger also needs to be ensured.

2.4.4.2 EXTERNAL HEAT EXCHANGERS

External heat exchangers are manufactured as *plate* (Figure 2.41) or *tubular* (Figure 2.42) heat exchangers. The heat transfer medium and domestic or heating water to be heated flow past one another in a counter-current. External heat exchangers are insulated, with prefabricated heat insulating shells.

Advantages of external heat exchangers:

- The heat transfer capacity is higher than for internal heat exchangers.
- There is hardly any reduction in performance from limescale build-up.
- Several stores can be charged from one single heat exchanger.

Disadvantages of external heat exchangers:

- They are more expensive than internal heat exchangers.
- In most cases an additional pump is required on the secondary side of the heat exchanger. Therefore they are not an option for thermosyphon systems.

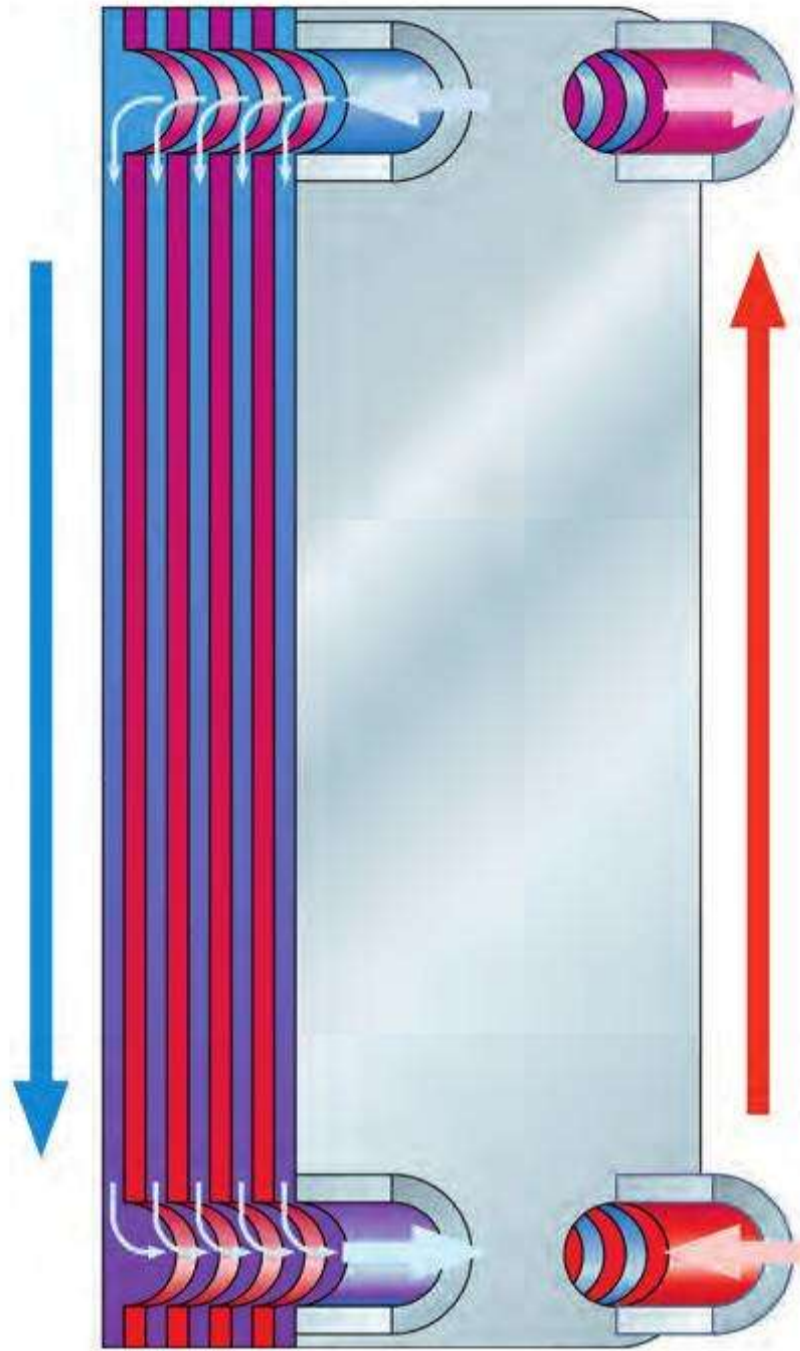

Figure 2.41.
Plate heat exchanger

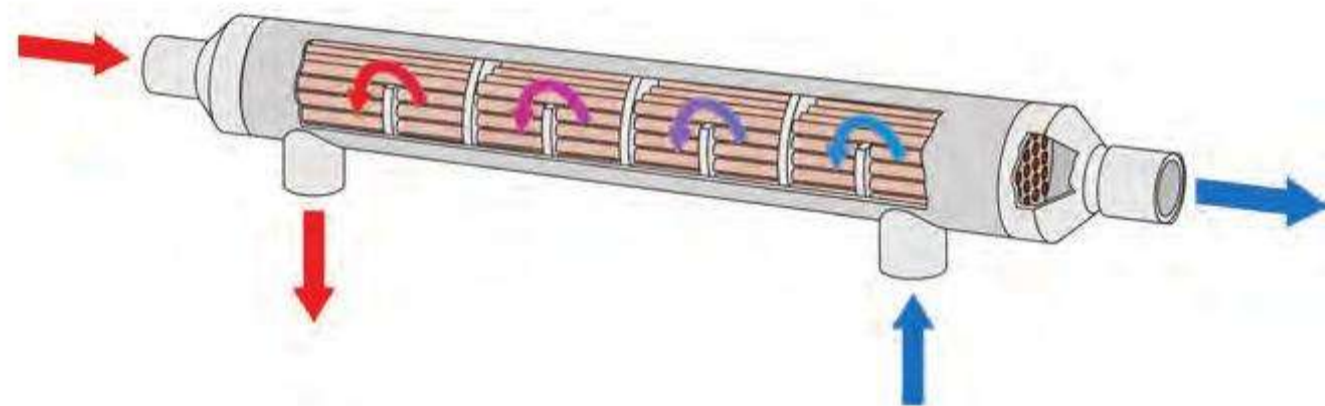

Figure 2.42.
Tubular heat exchanger

External heat exchangers* are mostly used in large systems. In such systems a heat exchanger can charge several stores, by which means the costs are lower compared with the installation of several internal heat exchangers.

2.4.5 Return-flow prevention

It is important to install a check valve or gravity brake in the return flow between the pump and collector (Figure 2.43). This should be dimensioned so that the lifting force of the hot heat-transfer medium is not sufficient alone to open the valve. Thus the store is prevented from being cooled down by the collector when the pump is not working (mostly at night). To prevent in-tube circulation in tubes larger than 15 mm × 1 mm (0.6 × 0.04 inches), a further return-flow preventer could be installed in the flow pipe.

In some systems, return flow is prevented by letting the hot water pipe from the store make a downward bend at least 30 cm (11.8 inches) deep. In thermosyphon systems return-flow prevention is more difficult, as the check valve may not disturb the flow.

2.4.6 Rapid air bleeders

At the highest point of every solar energy system, an automatic air bleeder with stop valve, or a manual air bleeder must be provided (Figure 2.44). Only in the case of special concepts with a high flow rate, or drainback systems, is it possible to have the

* Plate heat exchangers are referred to here; tubular heat exchangers are used mainly in swimming pool systems.

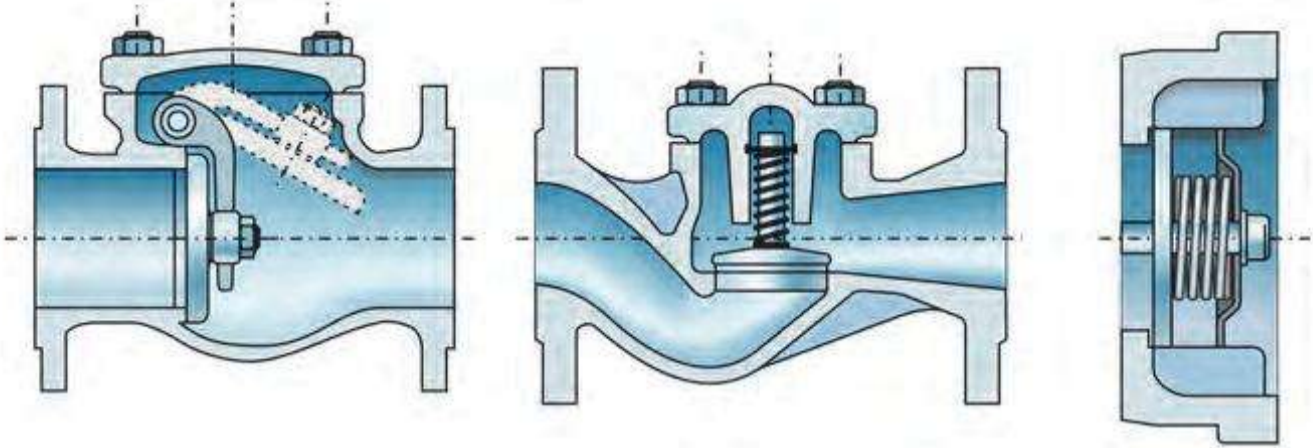

Figure 2.43. Return-flow preventers

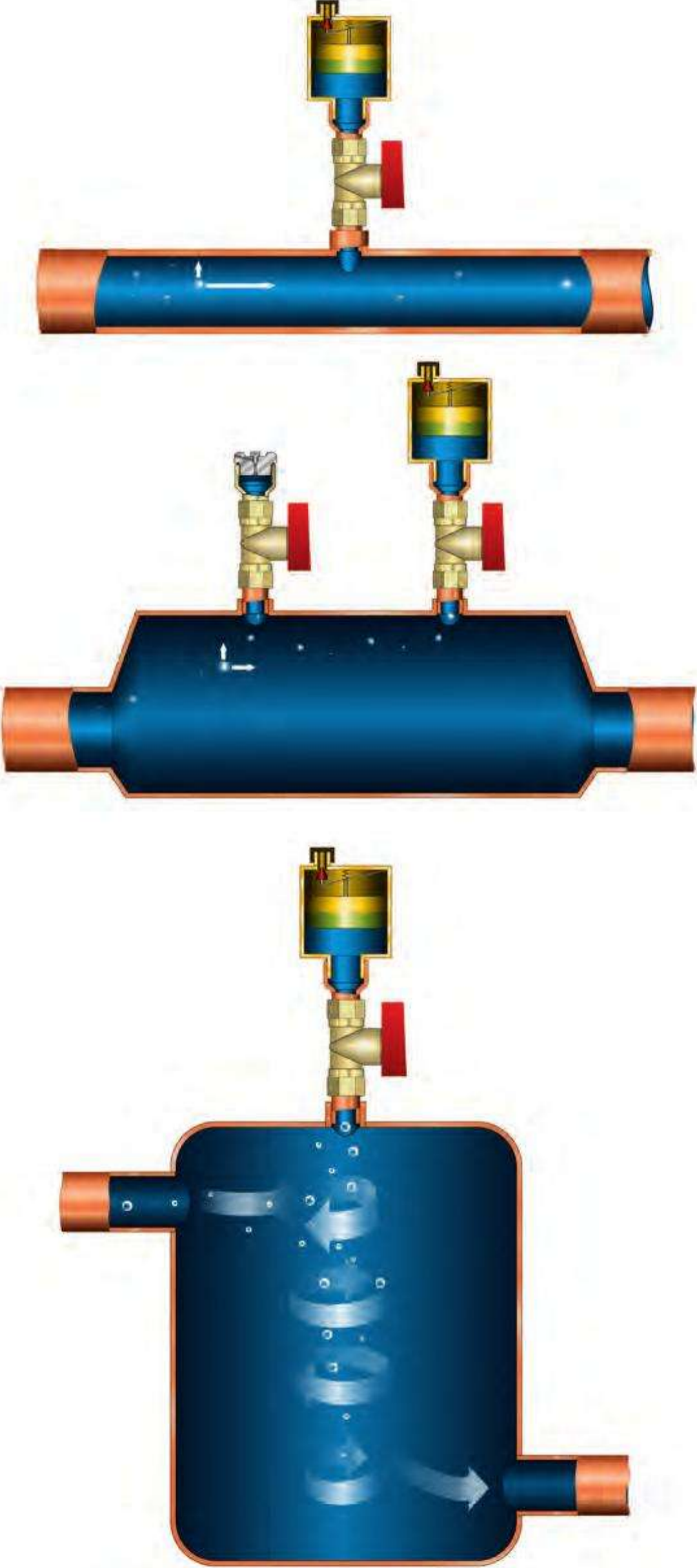

Figure 2.44. Rapid air bleeder, manual air bleeder, check valve, air separator. Top: poor air bleeding. Middle and bottom: good to very good air bleeding

air bleeding in the cellar by the use of corresponding pumps. The air bleeder must be glycol-resistant and have a temperature resistance of at least 150°C (302°F) (all-metal air bleeder). This serves to bleed the air from the solar circuit after filling with the heat transfer medium and during operation as necessary. The valve must be closed, as otherwise there is the risk that, during a stagnation situation, evaporated heat-transfer medium will escape via the automatic air bleeder.

2.4.7 Flowmeters

Small mechanical volumetric flow display units permit control of the volumetric flow. With certain flowmeters (for example Taco-Setter; see Figure 2.45) the volumetric flow can be reduced within certain limits by means of a flow control valve. It is, however, better to reduce the volumetric flow by means of the pump power settings because in this way it is also possible to save power. It is very easy to see with the flowmeter whether a flow exists or not.

2.4.8 Safety devices in the solar circuit

2.4.8.1 SAFETY VALVES

According to European standard EN 12976, each section of the collector field that can be shut off must be fitted with at least one safety valve. ICS systems must be fitted

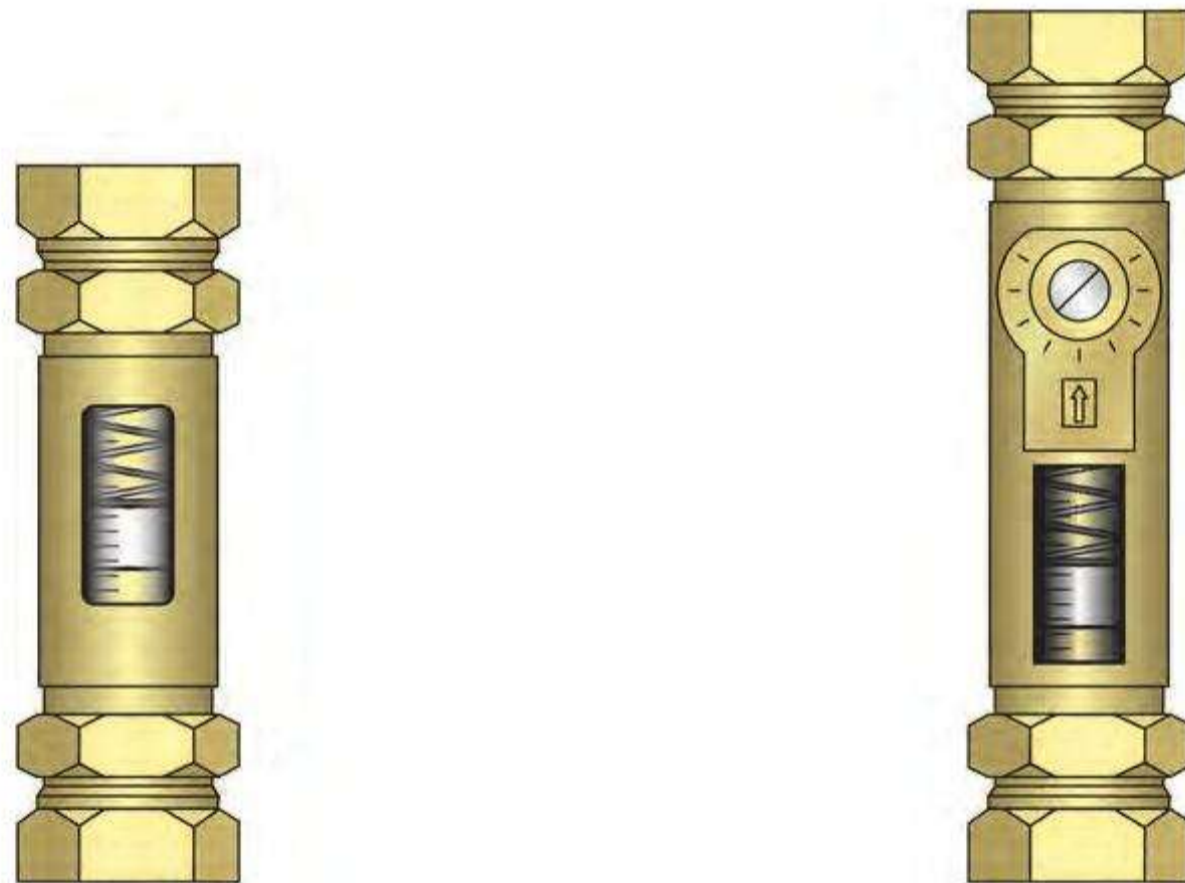

Figure 2.45.
Taco-Setter. Manufacturer: Taconova
GmbH, Singen

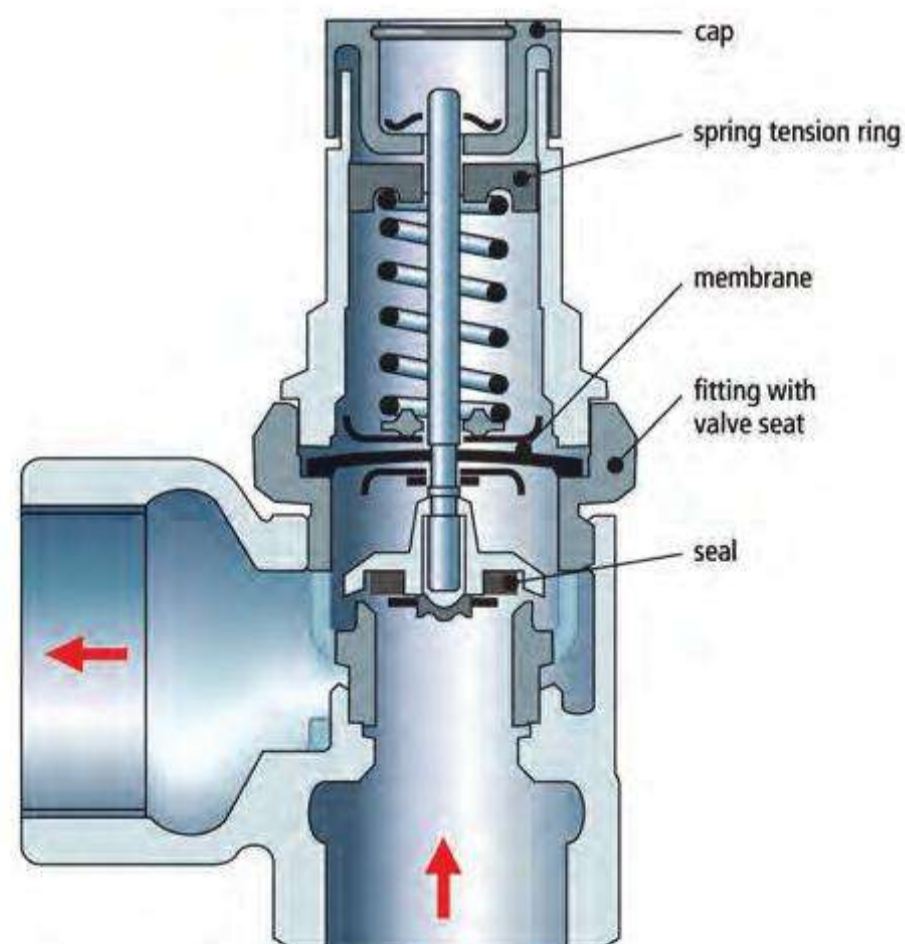

Figure 2.46.
Safety valve

with at least one safety valve, which may be integrated with an inlet combination. The safety valve should resist the temperature conditions it is exposed to, especially the highest temperature that can occur. The safety valve should resist the heat transfer medium. The safety valve should be dimensioned so that it can release the highest flow of hot water or steam that can occur. The dimensions of the safety valve(s) should be well designed.

2.4.8.2 MEMBRANE EXPANSION VESSELS (MEV)

The expansion vessel is an enclosed metal container. In the middle of the tank an expandable membrane separates the two media flexibly: on one side there is nitrogen, which is under an initial pressure, and on the other side there is the solar liquid, which enters the MEV when heated and after a pressure rise (see Figure 2.47).

The MEV is connected to the collector piping system so that it cannot be cut off and thus absorbs the temperature-related volume changes in the solar liquid. The size of the expansion vessel should be sufficient for the liquid content of the collector field. If the heat cannot be taken away by the solar liquid (for constant heat absorption in the solar collectors, and if the solar pump fails) the liquid evaporates when it reaches the evaporation temperature (this is pressure dependent).

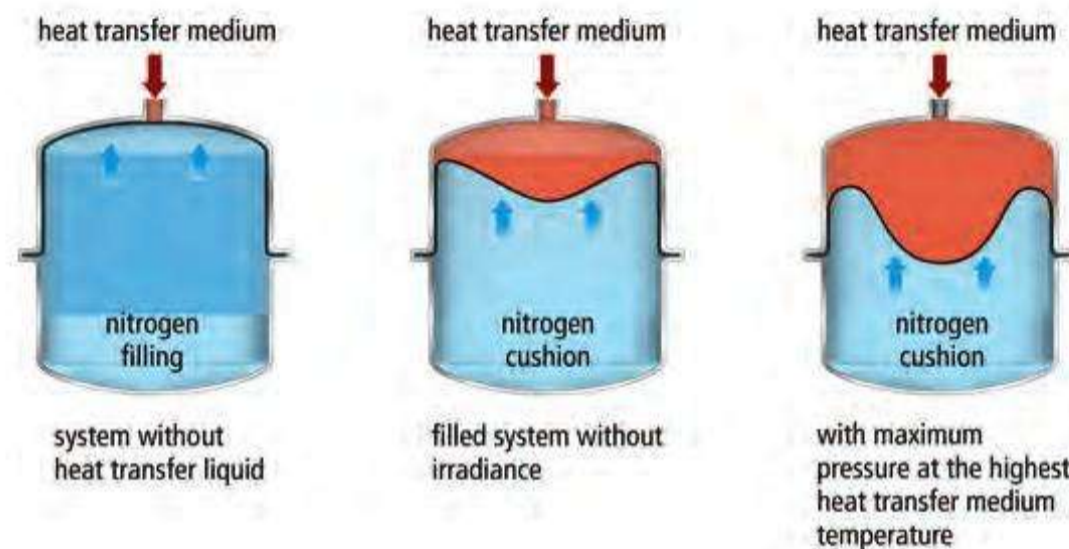

Figure 2.47.
Different operating conditions in
membrane expansion vessels

If the expansion vessel is designed for additional take-up of the collector content, the solar liquid can be displaced into the vessel so that the maximum permitted operating pressure is not reached and the safety valve does not respond (intrinsically safe system).

Expansion vessels are available in the standard sizes 10 l, 12 l, 18 l, 25 l, 35 l and 50 l (2.6, 3.2, 4.8, 6.6, 9.3 and 13.2 gallons).

The glycol resistance of the membrane (made of, for example, EPDM) is important. As this is not always true for membrane expansion vessels for heat installations, special expansion vessels are used in solar thermal systems.

2.4.9 Solar station

In several systems on the market, the functions of pump, control unit, valves and connections have been integrated into a single unit, a so-called *solar station*.

2.5 Controller

The controller of a solar thermal system has the task of controlling the circulating pump so as to harvest the sun's energy in the optimum way. In most cases this entails simple electronic temperature difference regulation.

Increasingly, controllers are coming onto the market that can control different system circuits as one single device, and are equipped with additional functions such as heat measurement, data logging and error diagnostics, and can possibly take over the circulation control and boiler regulation. Beyond that a range of existing controllers have the possibility of regulating the revolutions of the solar pump. A smart design combined with high user friendliness plays an increasingly important role.

Simple LED-function controls at the display are meanwhile the exception. Instead the solar plant operator can read off temperatures or amount of heat harvested and

modify adjustments. Pictograms can help maintain an overview. Operational data can often be recorded on a data stick and analysed later.

The following figures indicate exemplary system varieties for an automatic controller.

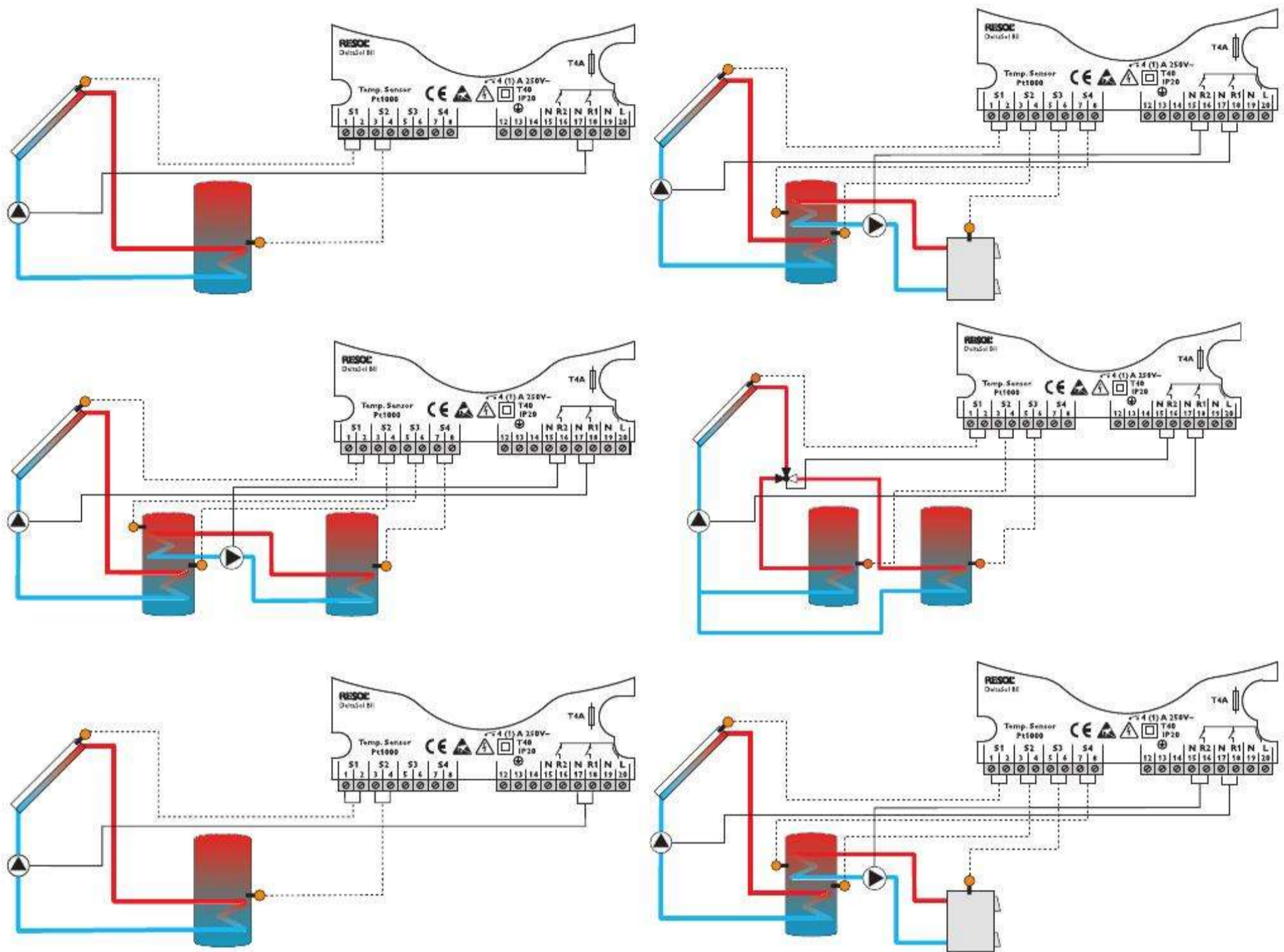

Figure 2.48.
 Left above: Standard system, above on the right: Standard system with controller for back-up heating
 In the middle: Two-store-systems
 Left bottom: Combination store, right bottom: Systems with two collector fields (Manufacturer: Resol, Hattingen)



Figure 2.49.
 DeltaSol BII
 (Manufacturer: Resol, Hattingen)

Product overview of solar controllers at a glance (part 1 of 2)

Manufacturer	Type	Inlets	Outlets	Display	Own consumption (W)	No. hydraulic systems	Rev speed controller	Heat meter	Data logger	Interfaces	Remote data transfer	Heating burner control system	Gross catalogue price in Euros
Controller for solar hot water installations													
Allsun	T80	8	8	LCD ²⁶⁾	n.a.	customer request	k. A.	optional	no	no	no	n.a.	n. a.
Bosch (Buderus) ²³⁾	Logamatic SC20	3	1	LCD	n.a.	1	WP	no	no	no	no	no	325.– ⁶⁾
Consolar	Control 300	5	2	LCD + LED	5	5	n.a	no	no	bus	no	no	357.–
Dolder	Sora-WL	5	1	LCD ¹⁾	2.1	1	WP ²⁾	yes	no	no	no	no	347.70
IMC	Basis-Mini 2	2	1	no	< 2	1	WP ²⁾	no	no	RS232 extensible	extensible	no	n. a.
Prozeda	Basic	3	1	LCD	0.5	1	WP	no	no	n. a.	no	no	n.a.
Resol	Deltasol BS	4	2	LCD ¹⁾	2	9	WP	yes	no ¹⁹⁾	Resol V Bus	yes	no	324.–
Sorel	TDC2	3	2	LCD ²⁶⁾	n.a.	2	PA	yes	yes	USB, Ethernet optional	optional	yes	243.25
Steca	TR 0301 sc	3	1	LCD ¹⁾	1	1	WP	no	yes	no	no	no	n. a.
Technische Alternative	ESR 21	3	1	LCD	1	4 ⁸⁾	PA/WP	yes	no	yes	add-on module	no	128.– to 143.– ⁹⁾
Tem	ES 5910 S	4	2	LCD	n.a.	9	WP	no	no	eBus	yes	no	n. a.
Wagner	Sungo S	4	1	LCD	≤ 0.5	2	WP	no	no	no	no	no	224.91 ⁶⁾
Watts	Advanced Solar	6	3	LCD ¹⁾	n.a.	5	PA	yes	optional	optional	optional	optional	n. a.
Vaillant	Auromatic 560	6	6	LCD	3	3	WP	yes	no	vrDialog	no	yes	307.–
Varmeco	Vario fresch-pur	25	19	LCD	7	1 ¹⁵⁾	WP	no	no	yes	no	yes	n. a. ²²⁾
Controller for heating support system													
Allsun	T100	9	9	LCD	< 4	freely programmable	WP	yes	yes	RS232, Ethernet	Internet + GPRS	yes	627.–
Consolar	Control 601	10	6	LCD + LED	8	3 ¹⁵⁾	PA	yes	yes	Bus, RS232	no	yes	785.40
Dolder	Sora-WX	10	6	LCD ¹⁾	3.8	19 ¹⁵⁾	WP ²⁾	yes ¹⁴⁾	no	RS232, RS485	no	no	513.80
IMC	Basis-10	3	2	LCD	< 2	21 ¹⁵⁾	WP ²⁾	no	no	RS232 ²⁾	optional	optional	n. a.
Paradigma	Systa Solar/Systa Solar Aqua	4	2	LCD ¹¹⁾	2.5	1	WP	yes	no ¹⁷⁾	yes	yes	no	304.64 ⁹⁾
Prozeda	Vision plus	7	4	LCD	0.5	≥ 25	WP	yes	optional	SPI	optional	no	n. a.
Resol	Deltasol BS Plus	4	2	LCD ¹⁾	2	9	WP	yes	no ¹⁹⁾	Resol V Bus	yes	no	424.–
Sorel	TDC 3	3	2	LCD ²⁶⁾	n.a.	15	PA	yes	yes	USB, Ethernet optional	optional	yes	249.30
Steca	TR 0603 mc	7	4	LCD ¹⁾	≤ 3.0	40	WP	yes	yes	RS232, SD-Karte	no	yes	n. a.
Technische Alternative	UVR 61-3	6	3	LCD	2	42 ²⁴⁾	PA/WP	yes	no	yes	add-on module	yes	177.– to 248.– ⁹⁾
Tem	PS 5512 SZ	7	5	LCD	n.a.	79	WP	optional	no	eBus	yes	no	n. a.
Wagner	Sungo SL	5	2	LCD	≤ 1.5	3	WP	yes	no	no	no	planned	296.31 ⁶⁾
Wolf	SM1	4	1	LED ²⁰⁾	1.7	1	n.a.	yes	no	eBus	yes ²¹⁾	yes	n. a.
Vaillant	Auromatic 620/2	10	13	LCD	5	12	WP	yes	no	eBUS, vrDIALOG	vrnetDialog	yes	825.–

Table 2.6b.

Manufacturer	Type	Inlets	Outlets	Display	Own consumption (W)	No. hydraulic systems	Rev speed controller	Heat meter	Data logger	Interfaces	Remote data transfer	Heating burner control system	Gross catalogue price [€]
Multi-function controller													
Allsun	T300	18	18	LCD ²⁶⁾	< 4	freely programmable	WP	yes ²⁾	yes	RS232, Ethernet	Internet + GPRS	yes	696.–
Brötje	ISR-SSR	12 ²⁵⁾	11 ²⁵⁾	LCD ¹⁾	11	individually configurable	PA	no	no	LPB-Bus	yes	yes	821.10
Bosch (Buderus) ²³⁾	Logamatic SC40	8	5	LCD	n.a.	27	WP	yes	no	S232	yes	no	483 ⁶⁾
Consolar	Control 701	22	16	LCD + LED	10	3 ¹⁵⁾	PA	yes	yes	Bus, RS232	no	yes	1487.50
Dolder	Sora-W	7	3	LCD ¹⁾	3.8	19 ¹⁵⁾	WP ²⁾	yes ¹⁴⁾	no	RS232, RS485	no	no	398.30
Prozeda	Genius plus	10	7	LCD	1.5	≥ 100	WP	yes	yes	SPI	yes	no	n.a.
Resol	Deltasol E	12	7	LCD ¹⁾	4	30 ¹⁵⁾	WP	yes	no ¹⁹⁾	Resol V Bus	yes	yes	566.–
Solvis	Solvis Control 2	18	15	LCD ¹²⁾	5	16 ¹³⁾	PA/WP	yes	yes	in preparation	in preparation	yes	n.a.
Sorel	TDC5	6	3	LCD ²⁶⁾	n.a.	6	PA	yes	yes	USB, Ethernet optional	optional	yes	402.22
Steca	TR 0704	7 ²⁹⁾	4 ²⁸⁾	LCD ²⁶⁾	≤ 3.0	74	WP	yes ²⁷⁾	yes	RS232, IS-Bus	yes	yes	n.a.
Technische Alternative	UVR 1611	16	11	LCD ²⁶⁾	3	freely programmable	PA/WP	yes	no	yes	additional equip.	yes	500.– ⁴⁾
Tem	PM 2975 OGZ	12	9	LCD	n.a.	individually configurable	no	no	no	eBus	yes	yes	n.a.
Wagner	Sungo SXL	6	6	LCD ¹⁾	≤ 1.5	10 ¹⁵⁾	WP	yes	yes	yes	yes	yes	528.36
Wolf	SM2	5	5	LED ²⁰⁾	1.7	11	WP	yes	no	eBus	yes ²¹⁾	yes	n.a.
Vaillant	calorMATIC 430 mit VR 68	6	4	LCD	4 ⁷⁾	4	WP	yes	no	eBus, vrDIALOG	vrnetDialog	yes	855.–
Varmeco	System 014-2	25	19	LCD	7	1 ¹⁵⁾	WP	no	no	yes	no	yes	1524.–
Controller for heating support system													
Prozeda	Genius FWR	10	7	LCD	1.5	n.a.	WP	yes	yes	SPI	yes	optional	n.a.
Resol	Friwa	9	5	LCD ¹⁾	5	n.a.	WP	yes	no ¹⁹⁾	Resol V Bus	yes	no	1760.– ¹⁸⁾
Sorel	FWC 3	3	3	LCD ²⁶⁾	n.a.	2	PA	yes	yes	USB, Ethernet optional	optional	no	n.a.
Steca	FW 0603 mc	7	4	LCD ¹⁾	≤ 3.0	4	WP	yes	yes	S232, SD-Karte	no	no	n.a.
Varmeco	Varcon 201	4 ³⁾	2 ¹⁶⁾	LCD	3	n.a.	WP	no	no	optional	no	yes	1750.– ⁵⁾

PA = phase cut

WP = wave pack

¹⁾ back-lit dot-matrix²⁾ optional³⁾ plus 2 inlet temperature sensors for Solaroption⁴⁾ without mountings⁵⁾ complete fresh water station, additional charge for solar controller 118 Euros⁶⁾ temperature sensors inclusive⁷⁾ consumption of solar panel VR68⁸⁾ with 10 different programs⁹⁾ depending on accessories¹⁰⁾ 511 Euros for caorMATIC 430 and 344 Euros for VR68¹¹⁾ fault signal as display and acoustically by beep signal¹²⁾ touch screen¹³⁾ others in preparation¹⁴⁾ up to 2 energy metres¹⁵⁾ expandable¹⁶⁾ plus one for rev speed controller for solar option¹⁷⁾ built-in error memory¹⁸⁾ complete freshwater station with or without circulating pump 1590 Euros¹⁹⁾ externally connectable over intersection²⁰⁾ LCD display with operating modul BM-Solar²¹⁾ with accessories²²⁾ integrated controller only²³⁾ similar models also with Bosch brand Junkers²⁴⁾ with approximately 520 programs²⁵⁾ freely configurable²⁶⁾ graphic display²⁷⁾ three times²⁸⁾ extendable up to 16²⁹⁾ extendable up to 23

2.5.1 Control principles for temperature difference control

Two temperature sensors are required for standard temperature difference control. One measures the temperature at the hottest part of the solar circuit before the collector output (flow); the other measures the temperature in the store at the height of the solar circuit heat exchanger. The temperature signals from the sensors (resistance values) are compared in a control unit. The pump is switched on via a relay when the switch-on temperature is reached (see Figure 2.50).

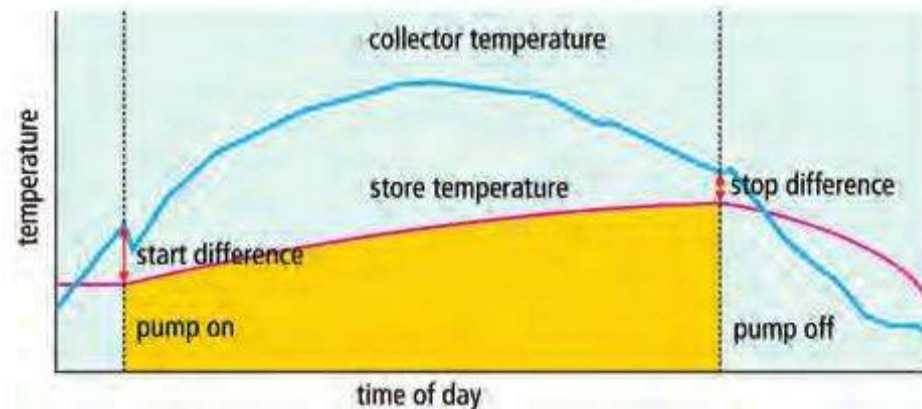

Figure 2.50.
Function of a temperature difference controller shown as the daily progression of the collector and store temperature (schematic)^{1,2}

The switch-on temperature difference depends on various factors. Standard settings are from 5 K to 8 K. In principle, the longer the pipeline from the collector to the store, the greater the temperature difference that should be set. The switch-off temperature difference is normally around 3 K. A third sensor can be connected for temperature measurement in the upper area of the store, which permits the draw-off temperature to be read.

An additional function is switching off the system when the maximum store temperature has been reached, as a means of overheating protection.

Frost protection is effected either by adding antifreeze to the collector fluid (as already discussed), or by using the drainback system. In the latter system, the collector circuit is only partly filled with water, and when the pump is off the collector is completely dry. This obviously places special requirements on the design of the collector and the piping. Drainback systems, when well designed so that no water is left in the collector or any piping that could freeze when the pump is switched off, automatically work together correctly with a temperature differential controller. When the danger of freezing occurs, the pump will be switched off because the store will then be always warmer than the collector.

2.5.2 Function and yield control, error signals

Because reheating always provides for sufficiently hot water (unless the boiler is manually switched off and not in stand-by mode in summer) a disturbance of the solar plant is often noticed too late or not at all. Error signals are therefore necessary in order to detect disturbances in time. For this there are several possibilities:

AUTOMATIC CONTROLLER WITH ERROR SIGNALS

These automatic controllers do an automatic check of certain state variables (such as resistance of the collector sensors), and in the case of a disturbance, e.g. short circuit in the sensor line, indicate the error on the display in normal text.

REMOTE DISPLAY OF SYSTEM PARAMETERS

With a remote display it will be possible to bring the system parameters 'from the cellar into the living room'. Thus comfortable monitoring as well as administration of the daily heat production performance becomes possible.

PROCESS MONITORING BY CONTINUOUS ANALYSIS OF SYSTEM DATA

A data logger records all the system values entered by the solar controller (e.g. temperature, volumetric flow), which then can be analysed over a PC-interface with the help of appropriate software.

REMOTE DATA TRANSMISSION

For larger solar plants a central capture of the operating data is done using a data logger, and long-distance data transmission over the telephone network creates a

meaningful possibility of controlling the system parameters effectively. In this way an improved monitoring of the system as well as rapid problem recognition is possible.

YIELD CONTROL

Apart from the functional control of a thermal solar plant the yield control (especially with large solar installations) plays an increasingly important role. The yield can be captured either through one or more separate heat meters or a heat meter that is already integrated in the controller.

A heat meter consists of:

- a flow rate meter (turbine or impeller water meter inserted into the return flow in storage tank proximity, more rarely magnetic-inductive);
- one temperature sensor each in both the supply and return flow; as well as
- electronics for the calculation of the heat yield.



Figure 2.51.
Temperature sensor, heat meter
and flow rate meter
(Manufacturer: Resol, Hattingen)

Devices without continual capture of the volumetric flow or with measurements of supply and return flow temperatures which have been taken too far apart, cannot deliver sufficiently precise results in the sense of heat metering. They enable only an estimation of the energy yields.

For the correct capture of heat metering it is important to pre-set the mix proportion of water–propylene–glycol at the heat meter or in the regulator.

With the support of heat metering the daily yield or the yield obtained over a certain period can be captured, read off and evaluated, in order to predict the efficiency of the system.

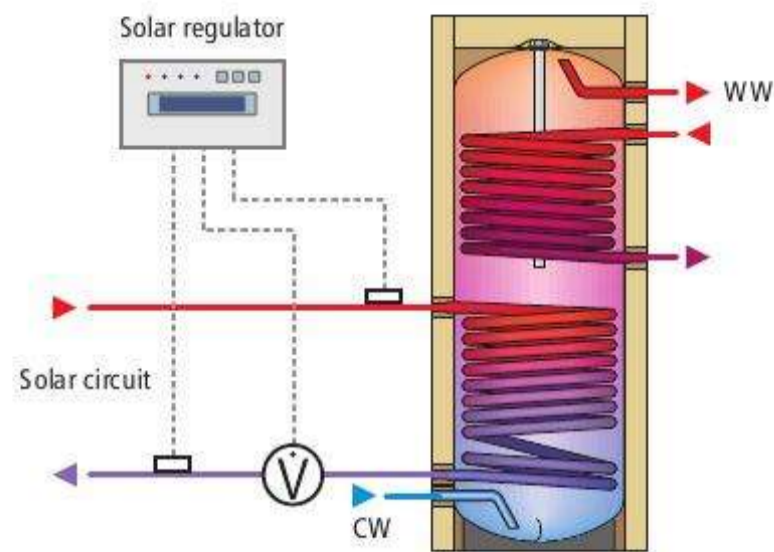

Figure 2.52.
Components of the heat meter in the
collector circuit

INPUT/OUTPUT-CONTROLLER (IOC) – AUTOMATIC YIELD MONITORING OF SOLAR THERMAL SYSTEMS

The company RESOL (Electronic Controllers GmbH located in Hattingen) introduced to the market a device to monitor the energy yield of solar thermal systems. With this controlling device the operator can receive the certainty that his/her solar plant functions. Since February 2008 a program for support during system analysis has been available, which visualizes the recorded measuring data and thus simplifies error detection.

The so-called input/output controller (see Figure 2.53) was developed in cooperation with the Institute for Solar Energy Research (ISFH) in Hammeln–Emmerthal and has proven its effectiveness in test operation in over 20 solar plants.



Figure 2.53.
Product photo of IOC
(Manufacturer: RESOL, Hattingen)

The device executes a daily, fully automatic evaluation of the solar plant. The basis for the evaluation is the comparison between the measured solar yield (actual value) and the expected solar yield (desired value). When calculating the desired value the real-world weather, temperature conditions in the solar store as well as system parameters from the planning process are considered. In this way the interaction of collectors, pumps, heat exchangers and automatic controllers is directly controlled (see Figure 2.54).

In the case of a deviation between the actual and desired value of more than 20% a technical problem is assumed.

A signal is displayed on the control device and can be passed on to a signalling device (light bulb, siren) or to a building instrumentation with the help of a signal relay. The fault signals, including the date of the occurrence, are saved until they are acknowledged within the system. The customer or operators can check the system status at any time.

For the support of error detection both the measured values of the sensors and different daily balances, for example the daily actual working time, are recorded over

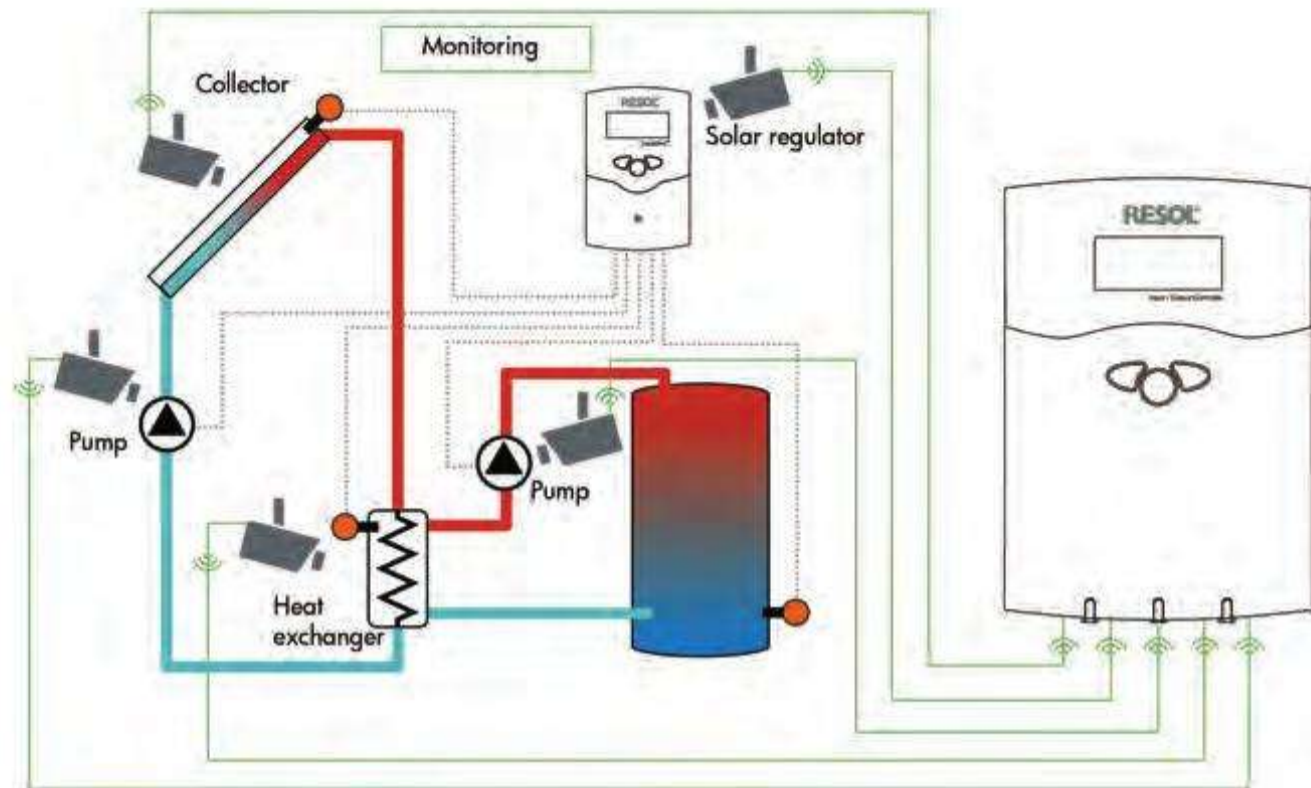

Figure 2.54.
Diagram of the components
monitored by IOC
(Manufacturer: RESOL, Hattingen)

approximately two months. Additionally, up to two heat quantity measurements are tracked, so that the input/output controller can replace two separate heat meters. The measured values, recorded in 5-minute intervals, as well as the daily balance, can be retrieved with a modem. The software IOC View of RESOL enables visualization and analysis of the recorded data on a PC. The IOC View accelerates the error diagnostics and so reduces the downtime of the system and the consumption of expensive additional heating energy. The measured and the expected daily yields as well as the fault signals are displayed with the daily solar radiation values in a combined input/output diagram (see Figure 2.55). Hence, a rough analysis of the functioning of the solar plant is possible.

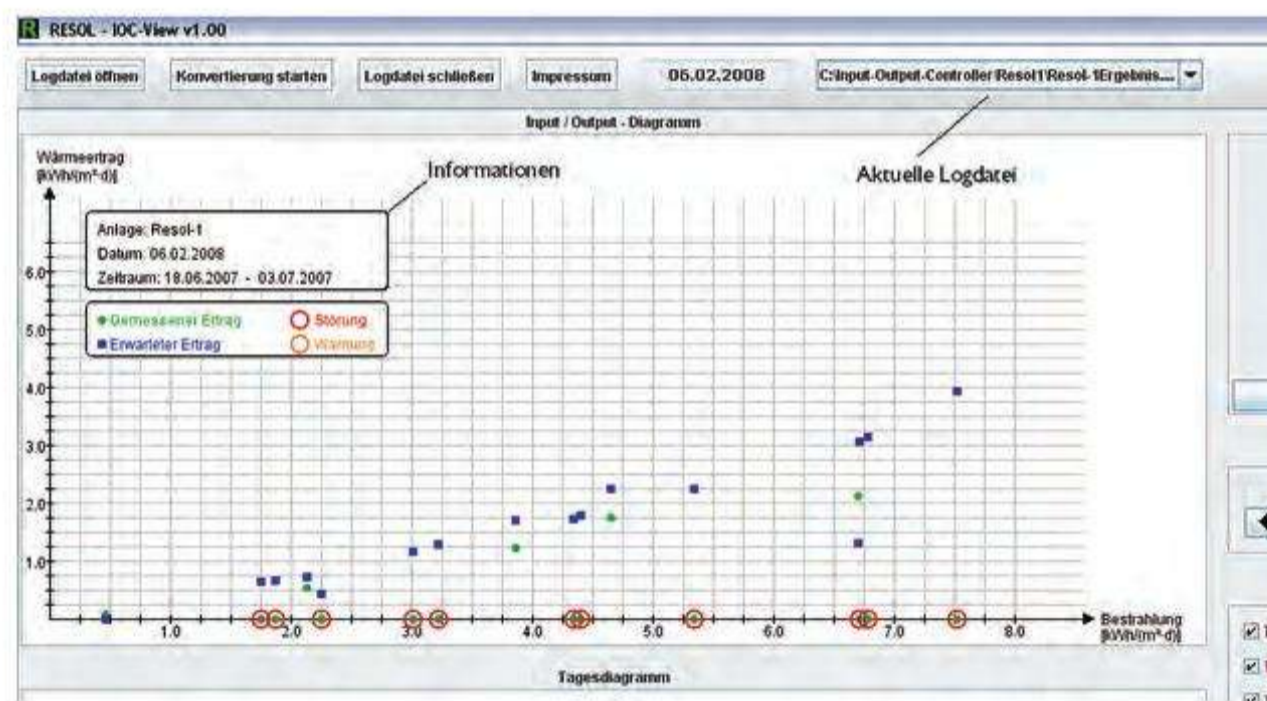

Figure 2.55.
IO-diagram of a monitored system
(Manufacturer: RESOL, Hattingen)

Each point in the input/output diagram can be allocated uniquely to one day. By moving the mouse over the point one receives further information on the balance values of that day, as for example the message with the daily radiation shown in Figure 2.56.

By clicking on the yield of this day, the daily diagram opens in the lower area of the display, in which the measured data over the time is represented. See Figure 2.57 bottom.

With the help of the control box in the legend (Figure 2.57 right) individual arrays can be faded in or out. By clicking on the shaft buttons one can change to the previous or following days. With the detailed analysis of the measured data in daily diagrams, special occurrences or the cause of faults can be analysed.

2.5.3 Temperature sensors

The effectiveness of the controller is heavily dependent on the correct mounting and function of the temperature sensors. The collector sensor can be fixed as a contact

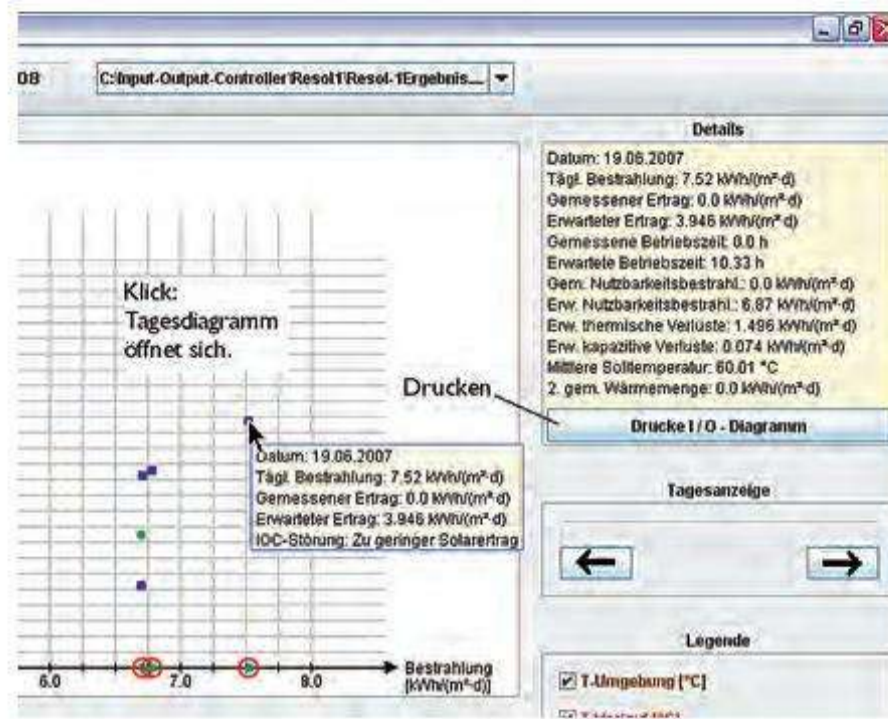

Figure 2.56. Additional information in the IO-diagram (RESOL, Hattingen)

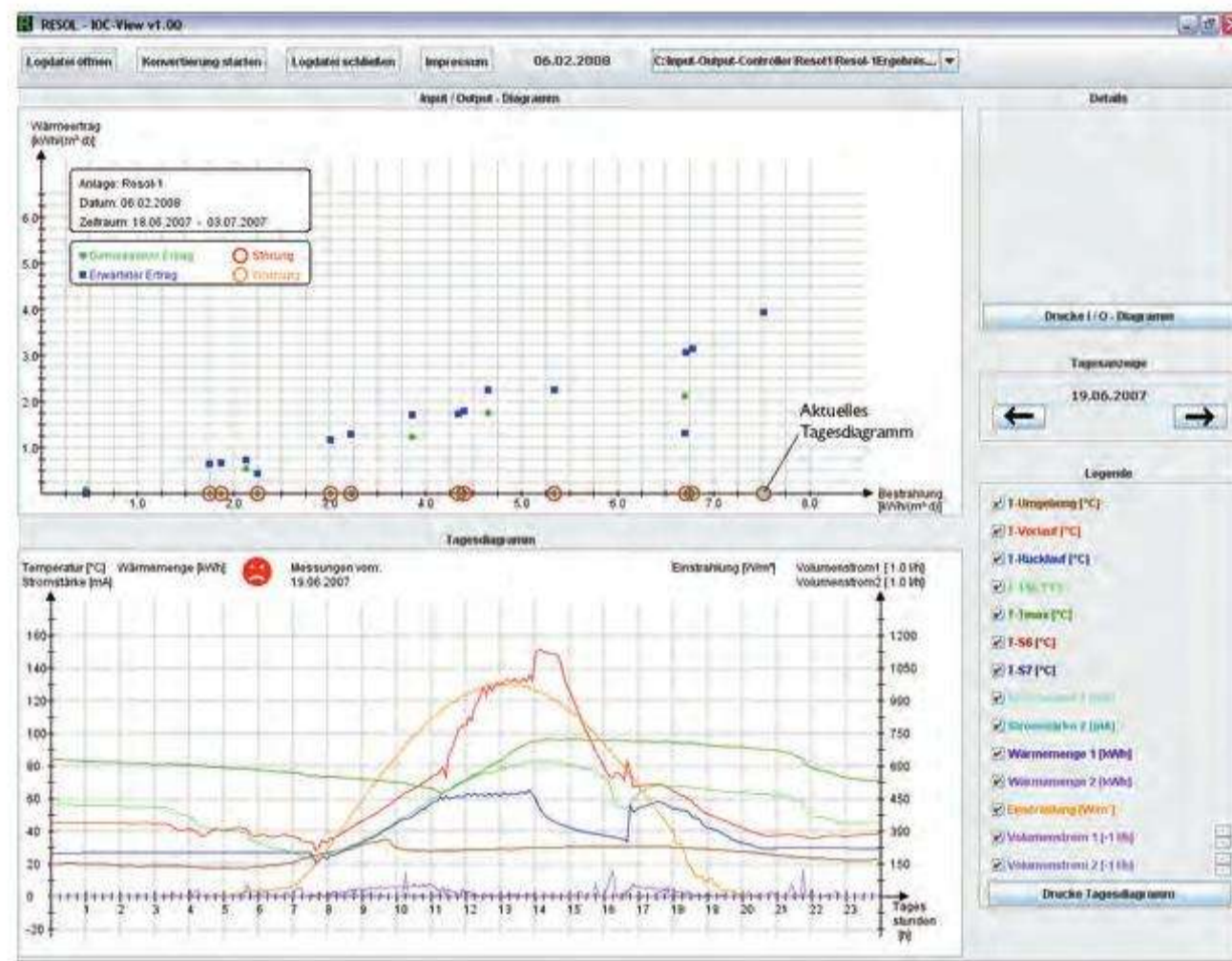

Figure 2.57. Combination of IO-diagram and days diagram in IOC view program (RESOL, Hattingen)

Table 2.7. Example of cause-effect assignment of errors in a thermal solar energy system for water heating. The temperature difference ($\Delta\theta$) refers to the temperature in the feed and return lines of the solar circuit¹⁴

Error description	Resulting effect
Collector connection faulty	Pump cycles
Collector sensor incorrectly positioned	Pump cycles
Leakage in solar heat exchanger	System pressure too high
Initial pressure of expansion vessel too low	System pressure occasionally too high
Initial pressure of expansion vessel too high	System pressure occasionally too low
Shut-off valve in solar circuit closed	Temperature difference ($\Delta\theta$) too high
Cable break between controller and pump	Temperature difference ($\Delta\theta$) too high
Collector temperature sensor defective/inaccurate	Pump runs at wrong times
Store temperature sensor defective/inaccurate	Pump runs at wrong times
Inputs on the controller defective	Temperature difference ($\Delta\theta$) too high; pump runs at night
Outputs on the controller defective	Temperature difference ($\Delta\theta$) too high; pump runs at night
Controller software defective	Temperature difference ($\Delta\theta$) too high
False setting of volumetric flow	Temperature difference ($\Delta\theta$) too high
Air bleeding incorrect	Temperature difference ($\Delta\theta$) too high
Gravity brake open	Pump also runs at night
Gravity brake contaminated	Pump also runs at night
$\Delta\theta$ setting unfavourable	Temperature difference ($\Delta\theta$) too high
Incorrectly programmed timer	Pump runs at night
Power failure	System pressure too high
Anode in store defective	Store corroded

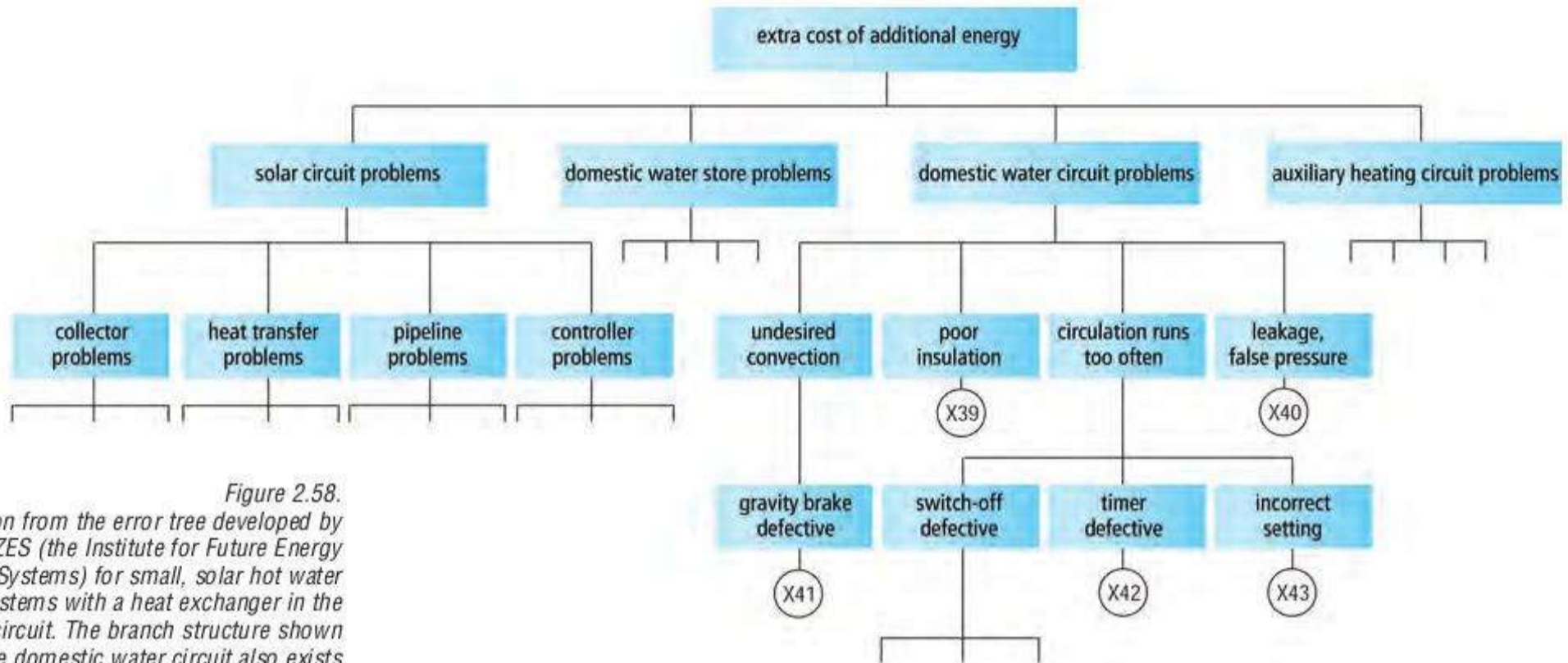

Figure 2.58. Section from the error tree developed by IZES (the Institute for Future Energy Systems) for small, solar hot water systems with a heat exchanger in the solar circuit. The branch structure shown in the domestic water circuit also exists for all other components¹⁴

sensor to the feed-collecting pipe of the absorber, or fixed directly to the absorber in front of the collector output, or used there as a submerged sensor (preferably always inside the collector).

The measuring point of the collector sensor should not be shaded.

In systems with a bypass circuit, the radiation from the sun and the temperature of the water flowing into the store (instead of the collector temperature) are measured in front of the three-way valve. The solar store sensor should be mounted at the height of the lower half of the solar circuit heat exchanger as a submerged sensor or contact sensor.

As temperature sensors and controllers are often matched to one another, it is normally not possible to exchange temperature sensors from different manufacturers.

The requirements with respect to temperature resistance are extremely high, in view of the high stagnation temperatures, especially in evacuated tube collector systems, and also with respect to the accuracy, for example during heat quantity recording.

2.5.3.1 SENSOR ELEMENTS

THERMISTOR

This widespread sensor type comprises elements that have an increasing electrical line resistance with increasing temperature; they can normally be used up to a maximum temperature of 150°C (302°F). In the normal measuring ranges for solar energy systems, their accuracy is ± 1.5 K. When used in solar controllers, they are connected to the controller by two wires.

When used for measuring collector temperatures, they can become damaged or even destroyed during long stagnation times in the collector. They are unsuitable for temperature measurement in vacuum tubes.

PT100, PT1000

Both of these elements are made from platinum wires, and they are suitable for temperatures from -200°C (-328°F) to $+850^{\circ}\text{C}$ (1562°F). Pt100 sensors are most frequently found in *four-wire circuits*. The Pt1000 sensors found on the market are equipped with two wires. Qualities A and B are differentiated according to the application temperature and measuring accuracy. Quality A is mostly used for accurate measurements in combination with *paired sensors*. Paired sensors (each with two sensors) are subject to a calibration procedure and, for example, for the calculation of heat quantities, are very accurate, as they behave consistently over the whole measuring range during temperature measurement. Class B elements are mostly used for the control of solar energy systems: their accuracy in system operation is $\pm(0.3 + 0.005\theta)^{\circ}\text{C}$, where θ is the temperature to be measured (in $^{\circ}\text{C}$).

Because of their high temperature resistance, platinum elements are also used for collectors with very high stagnation temperatures.

PV CELLS FOR MEASURING RADIATION

For controllers whose programmes are dependent on measuring solar radiation, *encapsulated PV cells* are generally used. They are suitable for simple radiation measurement, as is required here. Their resistance, which changes with the intensity of the radiation, acts as an input variable for the solar energy system controller. It must be ensured that the materials used for the cells and the housing do not change their properties in the course of time, which over the years would lead to permanent error measurements (for example do not use light-sensitive plastics, and protect the sensors from condensed water).

2.5.3.2 SENSOR HOUSING AND CONNECTING CABLES

The sensor housing protects the sensor element from damage and the influences of weather, and must be temperature- and corrosion-resistant. The materials used are therefore mostly tinned brass or stainless steel. In order to seal the housing from moisture the sleeves for the sensor cable are frequently fitted with a plastic that is rolled-in or pressed. The quality of this seal is of great importance for the permanent use of the sensor. If the seal is not permanent, or if it is damaged by high temperatures in the collector, the consequence may be incorrect temperature displays or even a short circuit in the sensor.

The connecting cables to the sensor are usually PVC- or silicon-sheathed cables. In the high temperature area PTFE cables are also used. In order to prevent damage to the cables of the collector sensor, protective pipes made of stainless steel or similar material are used in the external area.

PVC cables should not be used because of the potential environmental problems. The only permanently safe alternative for collector sensors is silicon cables with PTFE sheathing on the cores. These cables can resist temperatures of up to 230°C (446°F).

Unsuitable sensors can lead to faults or even to the complete failure of the solar energy system. Because there is little difference between the prices for high-quality platinum sensors with suitable housings and connecting cables and those for lower-quality sensors, there is no justification for the use of the latter.

2.5.4 Overheating protection

According to European standard EN 12976, solar energy systems:

shall have been designed in such a way that prolonged high solar irradiation without heat consumption does not cause any situation in which special action by the user is required to bring the system back to normal operation. When the system has a provision to drain an amount of drinking water as a protection against overheating, the hot water drain shall be constructed in such a way that no damage is done to the system or any other materials in the house by the drained hot water. The construction shall be such that there is no danger to inhabitants from steam or hot water from the drain. When the overheating protection of the system is dependent on electricity supply and/or cold water supply, this shall be stated clearly in the instructions and on the system.

The system can be protected against overheating in one of the following ways:

- By stopping the collector pump and letting the collector fluid boil in the collector until it is dry and heats up to its stagnation temperature. The fluid is expanded into a suitable expansion vessel. Here it is important that evaporated solar medium cannot escape from an automatic air bleeder. A valve beneath the air bleeder can prevent this.
- In drainback systems, by stopping the circulation pump so that the collector is drained.

- By continuing to operate the collector pump at night when the water in the store is too hot (requires electricity supply).
- By draining an amount of hot water from the store (often used in thermosyphon systems; requires water supply).
- By using a temperature-controlled cooling fin on the store.

Figure 2.37 illustrates the first principle in this list. The fluid will boil at its boiling temperature, which depends upon the pressure. The expansion vessel must be large enough to take the volume of liquid displaced from the collector due to evaporation, as otherwise the system would release the pressure via the safety valve and the system pressure would reduce too quickly after cooling. The response pressure of the safety valve should be 4 or 6 bar (58 or 87 psi). The expansion vessel must be approved for this pressure. The above operating condition means that the solar energy system is put under a certain stress. For example, if the evaporated condition happens too frequently the heat transfer medium will age more rapidly. In order to avoid this load, or to reduce it, the following measures can be used:

- By putting the collector at a steeper tilt angle, not only are the amount of excess heat and the stagnation times over the summer period reduced, but the yield in the winter is also increased.
- If possible, the excess heat can be used for swimming pool water heating, washing machines and dishwashers.
- In holiday periods, the gravity brake could be opened (by turning a handle or a slotted screw). In this way the solar store can discharge via the collector at night. Not all gravity brakes are accessible.

3 Systems for single-family houses

3.1 Introduction

There are several main types of solar water heater for single-family houses:

- *Thermosyphon and forced circulation systems.* Thermosyphon systems do not require pumps, as in this case gravity is used for liquid transport, whereas systems with forced circulation require circulating pumps for this purpose.
- *Open and closed systems.* Open systems have an open container at the highest point of the solar circuit, which absorbs the volumetric expansion of the liquid caused by the temperature changes. The pressure in open systems thereby corresponds at its maximum to the static pressure of the liquid column. Closed (sealed) systems operate with a higher pressure (1.5–10 bar; 21.8–145 psi), which influences the physical properties (such as the evaporation temperature) of the solar liquid. Special safety devices are necessary for closed systems.
- *Single-circuit (direct) and twin-circuit (indirect) systems.* In the first case the domestic water circulates from the storage vessel to the collector and back again. In the second case the system is separated into one solar circuit and one domestic water circuit. The solar circuit includes the collectors, the ascending pipes, the solar pump with safety equipment and a heat exchanger. A mixture of water and antifreeze agent can be used as the heat transfer fluid. The domestic water circuit includes the storage vessel as well as the cold water and hot water installations of the house.
- *Filled and drainback systems.* Indirect systems can have a collector circuit that is either completely filled or only partly filled. In the latter systems, which are called drainback systems, the collector drains completely when the collector pump is switched off.

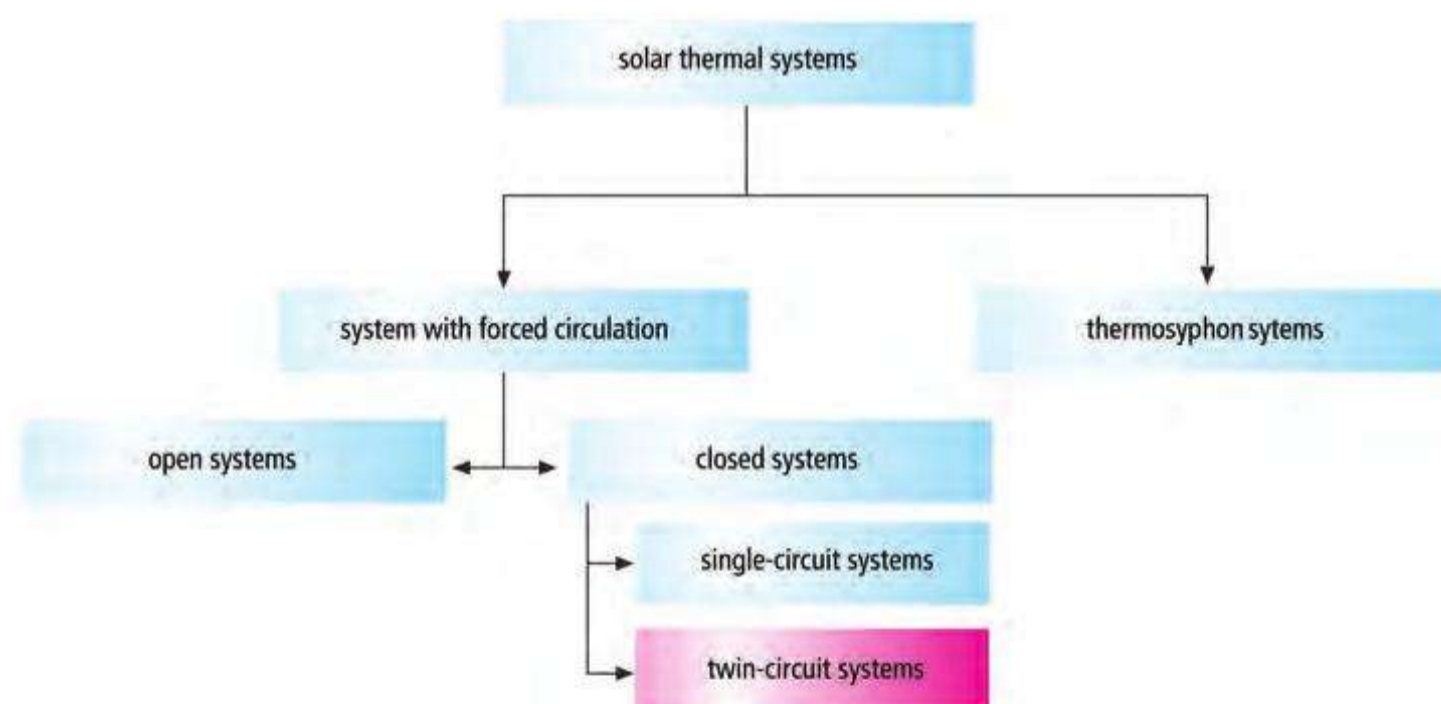

Figure 3.1.
Classification of solar thermal systems

Systems with forced circulation are predominant in temperate climates, such as in central and northern Europe. In southern Europe, Australia, Israel and other – mostly sunny – countries, thermosyphon systems are the most common type.

In order to provide an overview of the multiplicity of possible circuits, we shall divide them into the following functional sectors:

- solar energy feed: charging of the store with solar energy
- auxiliary heating: charging of the store by conventional heating
- heat removal: removal of the stored heat through hot water consumption or other means.

Then we shall list the essential variants of each and consider the most important systems, which can be combined from these. *Note that, for clarity, the schematic diagrams in this chapter do not show safety valves or vents.*

3.2 Systems for charging/discharging the store

3.2.1 Charging by means of solar energy

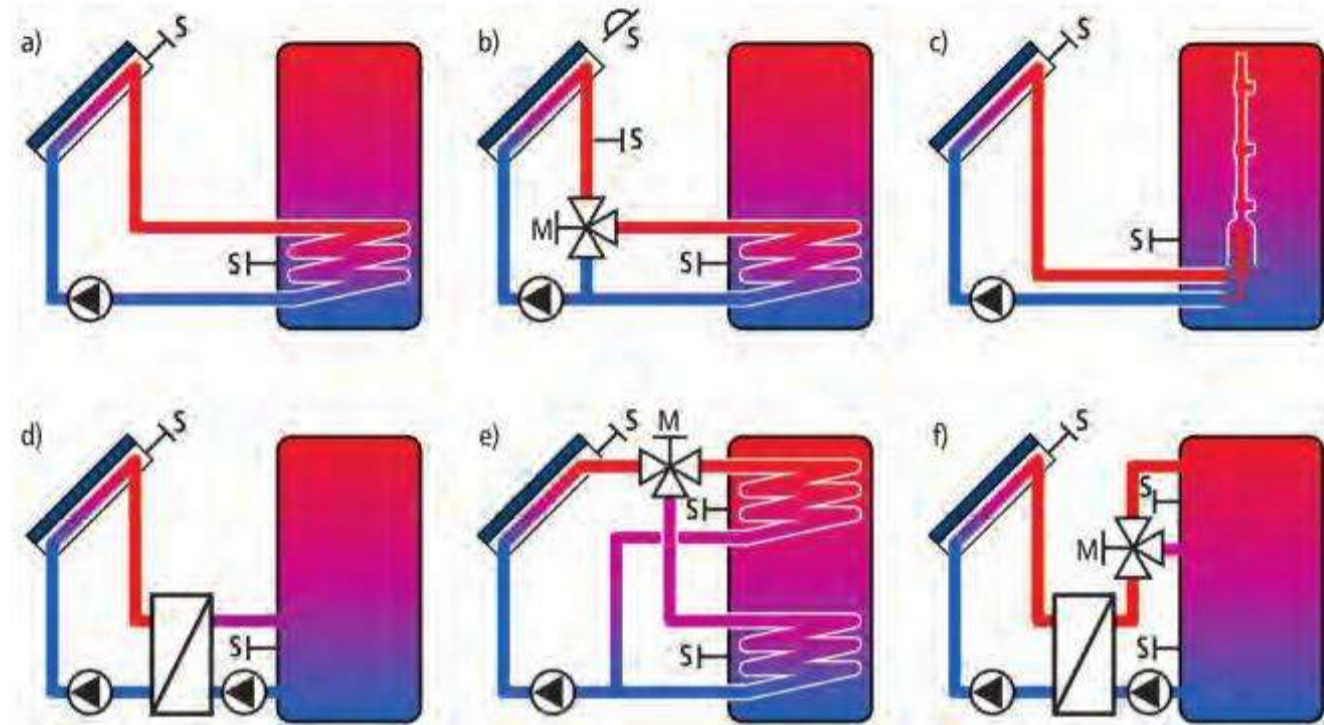

Figure 3.2.
Types of store charging with solar energy
(S = sensor)

- Internal solar heat exchanger.* The heat exchanger is normally designed as a finned or plain tube coil, which is arranged in the lower area of the store. Thermal transmission to the domestic water takes place through thermal conduction, and as a result of this convection takes place: that is, the heated water rises as a result of its lower density.
- Internal solar heat exchanger with bypass circuit.* This is a variant of system (a) for larger systems. A radiation sensor measures the solar radiation. At a threshold value of, for example, 200 W/m^2 the controller switches on the solar pump, and the three-way valve initially bypasses the heat exchanger. The solar circuit heats up. When the set temperature difference with the store has been reached at the flow sensor, the controller switches over the valve and the store is charged with heat.
- Stratum charging with self-regulating stratified charger.* The central core of this store-charging method is a riser pipe with two or more admission ports at different heights and a heat exchanger installed below. The heat exchanger heats up the water surrounding it in the riser pipe, and the water rises up. This causes a pronounced temperature-stratification effect, and in the upper area a useful temperature is very soon achieved.
- External heat exchanger.* The solar liquid flows through the primary side of an external plate heat exchanger. For charging the store a second circulating pump draws cold water from the bottom of the store. This flows through the secondary side of the heat exchanger in a counter-flow and then flows back into the middle of the store. An external heat exchanger has better thermal transfer properties than an internal type. Stores without internal fittings can also be used. The bypass circuit (b) can be implemented without the three-way valve by controlling the two pumps separately. For this purpose a sensor arrangement (b) should be selected.
- Stratified charging system with two internal heat exchangers and feed via a three-way valve at two different heights.*
- As (e) but with an *external heat exchanger*.

The advantage of stratified charging systems (rapid reaching of useful temperatures in the standby area) is greatest in connection with the *low-flow* concept. In low-flow systems, sometimes also called *matched-flow* or *single-pass* systems, only about 25 l (6.6 gallons) of heat transfer fluid circulates per square metre of collector area in one

hour. The effect of this is that the efficiency of the collectors is increased slightly, and that higher temperature differences occur between the collector and water tank. This can increase the system efficiency because less pump energy is needed, and after only a few hours a layer of hot water may accumulate at the top of the tank. If hot water is needed at that moment, it can be supplied entirely or almost entirely from the solar heat, and auxiliary energy is saved. Most solar water heaters can be used as low-flow systems, but there are also specially designed systems with optimized water tanks and heat exchangers. The advantage of low-flow systems is that thinner, and hence cheaper, standpipes can be used. These also lose less heat and, together with the minimal amount of heat transfer fluid and a smaller pump, help to reduce the total cost of the solar heating system.

3.2.2 Charging by means of auxiliary heating

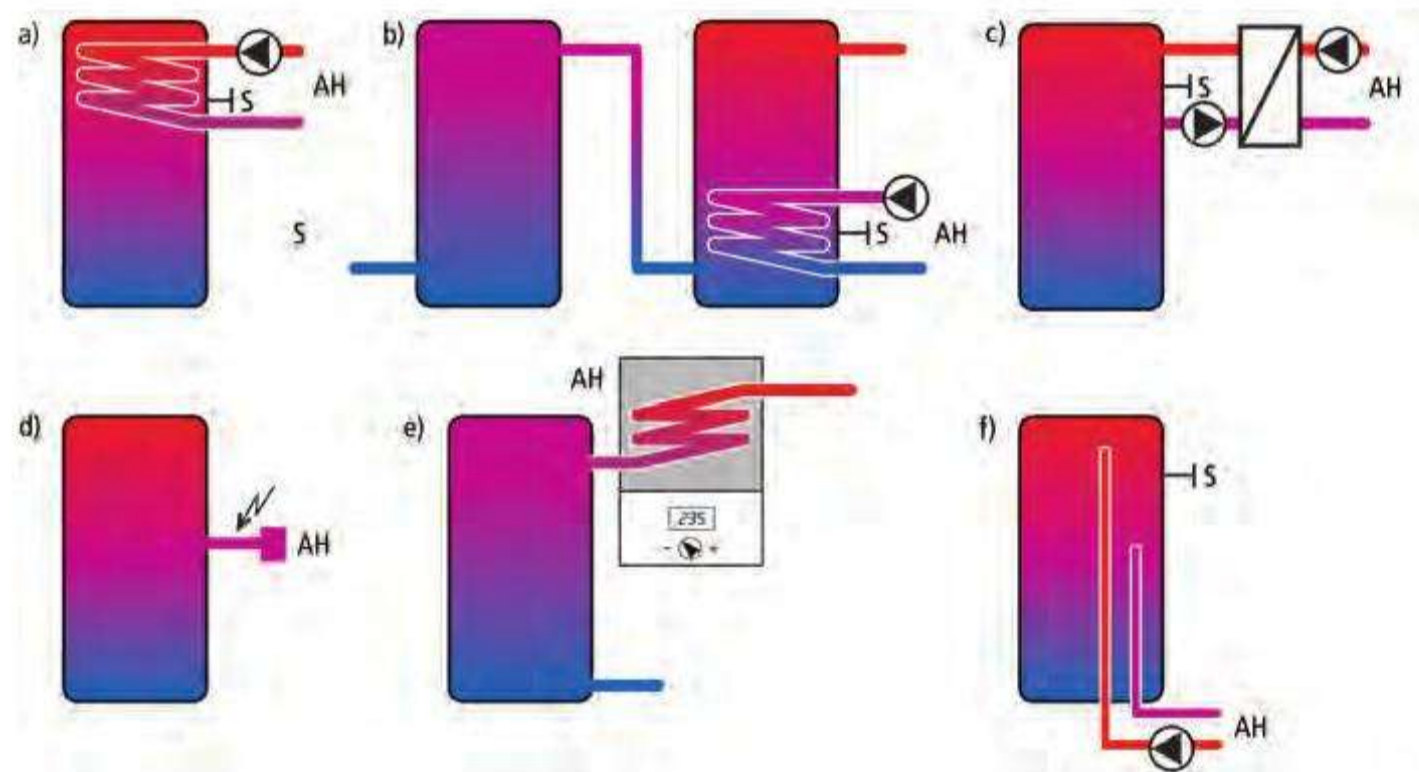

Figure 3.3.
Types of store charging with auxiliary heating

- (a) *Domestic water store.* The standby volume is heated as necessary via the upper heat exchanger, using an oil or gas boiler with store priority switching. Recently, in several countries, wood has started to be used again (for example in the form of pellets) as a growing fuel resource for heating purposes that is CO₂-neutral. In the case of the cascade connection of two stores the additional heat exchanger can be located in the top or bottom of the second store according to the size of the required standby volume.
- (b) *Buffer (thermal) store.* Direct top-up heating of a separate buffer store. Warm heating water is withdrawn from the middle of the store and hot water is fed in again at the top, as in (f), but in this case the pipes are installed at a corresponding height at the side.
- (c) *Domestic water store.* Auxiliary heating of the standby volume by an external heat exchanger.
- (d) *Domestic water store.* Electrical auxiliary heating of the standby area. Electrical power is acceptable for use as heating only in exceptional cases, as electricity generation involves high losses. (Electricity is generated in a conventional power station with an efficiency of about 30–50%, and on top of this loss are the line losses to the consumer.)
- (e) *Domestic water store.* Top-up heating by a downstream instantaneous heater (gas or electricity). The device must be thermally controlled and designed to accept preheated water: that is, it only heats up as much as is required to achieve a set exit temperature. Advantage: the whole store is available for solar energy, and there are lower store losses compared with top-up heating inside the store. Disadvantage: in the case of electricity, similar to (d). In the case of gas or oil, there are very few compatible appliances.
- (f) *Buffer (thermal) store.* Top-up heating via admission pipe. The store-charging pump draws the water to be heated from the middle of the store. This is heated by the boiler and fed into the top of the store via an admission pipe.

3.2.3 Store discharge

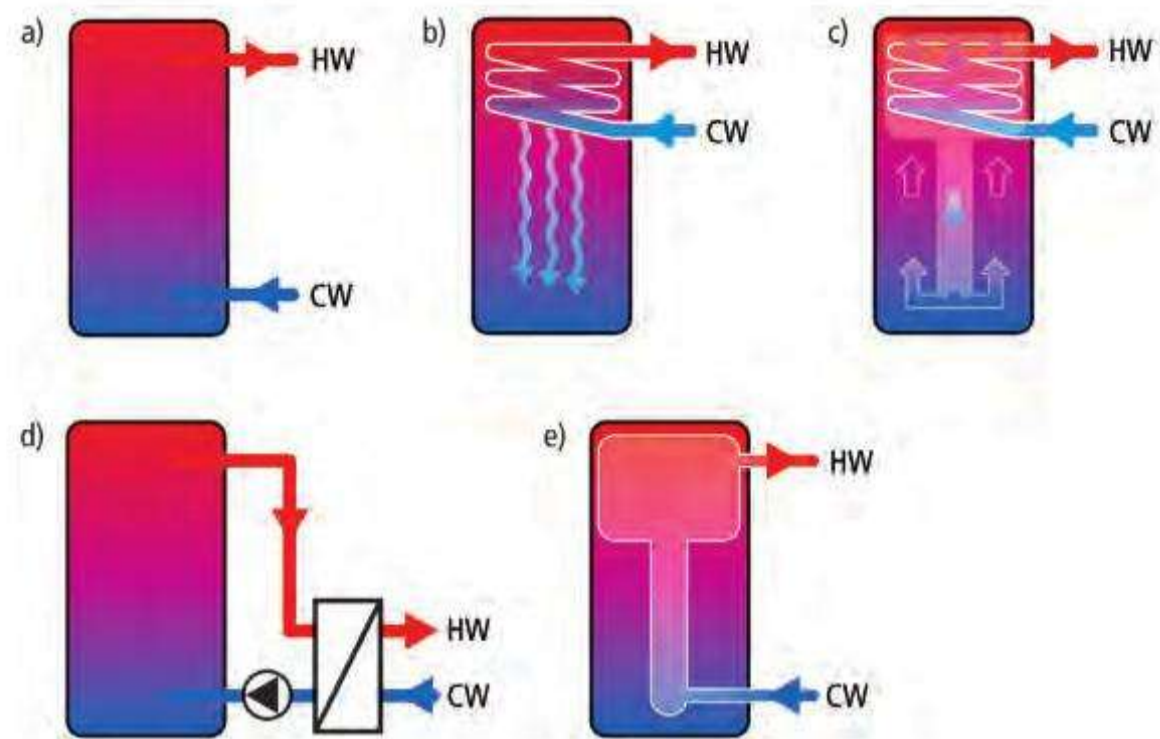

Figure 3.4.
Methods of store discharge

- (a) *Domestic water store.* The water is withdrawn from the top in the hottest part of the store (standby area). Cold water flows in at the bottom in a corresponding amount. Almost the whole amount of stored hot water can be withdrawn.
- (b) *Buffer store.* Discharge takes place in the upper area via an internal heat exchanger. The disadvantage is that the upper storage area is significantly cooled down by the cold water (8–12°C; 43.4–53.6°F) flowing into the heat exchanger. This causes a significant amount of circulation, which causes mixing of the waters: that is, the store temperature layers are destroyed.
- (c) *Improvement on (b).* The cooled store water descends within a downpipe and pushes the warmer water uniformly upwards. In this way the hottest water is always available at the top, and the stratification is hardly disturbed.
- (d) *Buffer store.* Discharging is through an external heat exchanger.
- (e) *Combined store.* Cold water enters the domestic water store right at the bottom. It heats up according to the layers in the buffer store and is removed from the hot area at the top.

Two groups of systems can be combined from the modules described above:

- systems for domestic water heating
- systems for domestic water heating and heating support.

These are described in the next two sections.

3.3 Systems for heating domestic water

3.3.1 Standard system

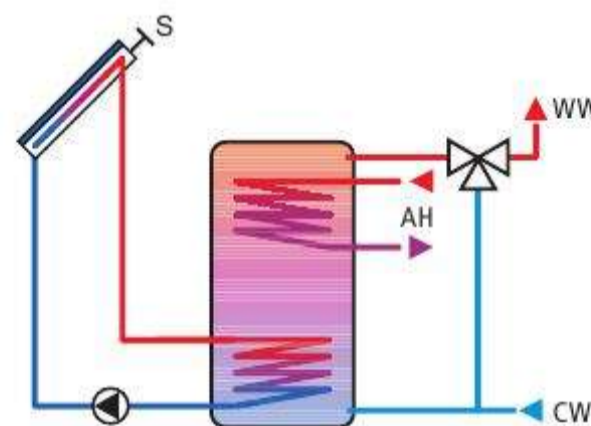

Figure 3.5.
Standard solar system

The standard system has been widely accepted for use in smaller systems, and is offered by many manufacturers. It is a twin circuit (indirect) system with an internal heat exchanger for solar heat feed and a second one for top-up heating by a heating boiler. In the store there is domestic water, which can be limited to a set maximum draw-off

temperature by means of thermostatic three-way blending valve. The circuitry is comparatively easy to implement, as well-tried control principles are used. The solar circuit pump is switched on as soon as the temperature in the collector is 5–8 K higher than the lower store area. When the temperature on the boiler controller for the standby volume falls below a set temperature (for example 45°C; 113°F), the boiler provides the necessary top-up heating. During this time, the space heating circuit pump (if connected) is normally switched off (domestic hot water priority switching).

3.3.2 Water heating using the flow-through principle

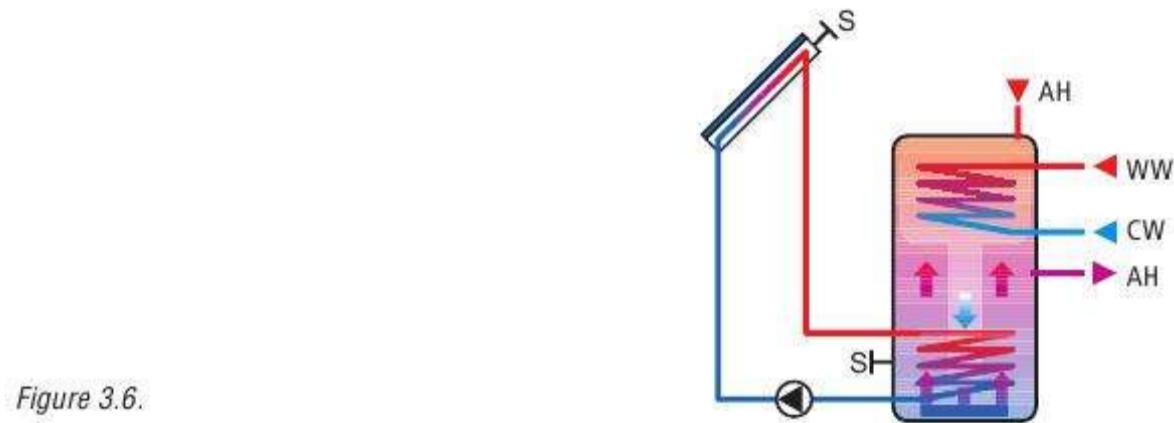

Figure 3.6.

Figure 3.6 indicates a buffer store with internal charge and output heat exchanger including internal downpipe and direct auxiliary heating through the boiler (for hygienic reasons, here used exclusively for water heating).

3.3.3 Water heating by means of tank-in-tank store



Figure 3.7.

In a tank-in-tank storage system the store contains a smaller domestic water volume compared to a standard system – this results in a shorter retention time of water in the store. The surrounding buffer water is used as storage buffer for the heat.

3.3.4 Water heating over external heat exchanger

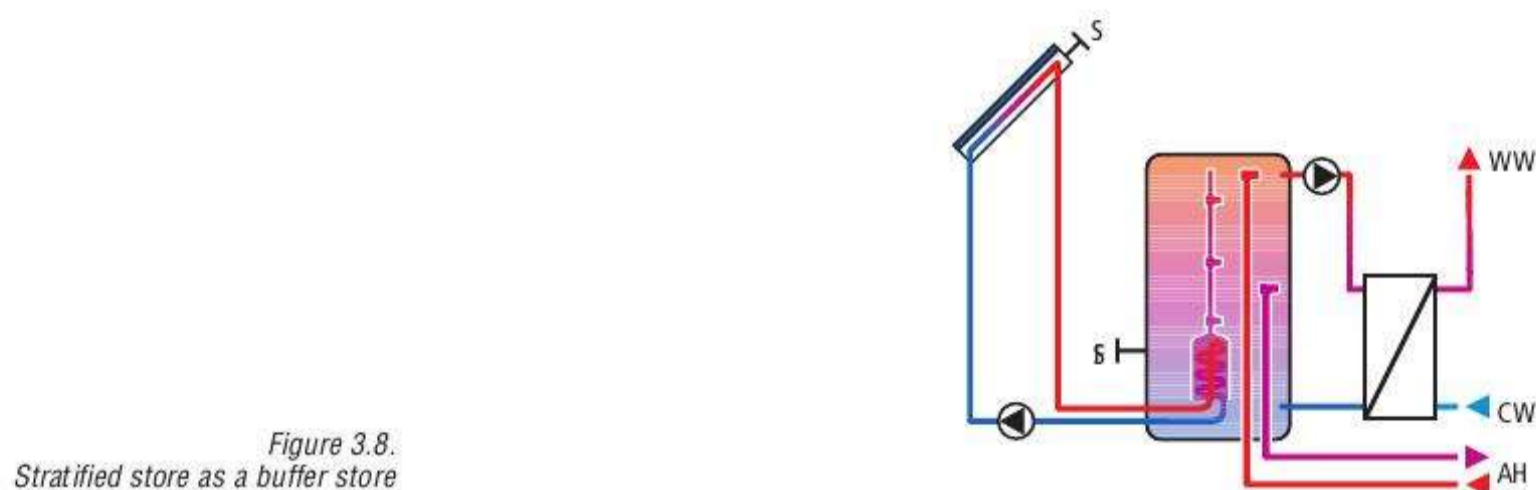

Figure 3.8.
Stratified store as a buffer store

Through the use of a stratified store either as a domestic hot water store or as a buffer store, the heat from the solar collector is fed directly into the matching temperature layer in the store. The significantly reduced mixing process leads to a usable temperature level much faster than all the other systems described here and the frequency of auxiliary heating is reduced. When the stratified store operates with buffer water, the heat for the domestic water is discharged by means of an external once-through heat exchanger. Also important for the performance of this system is good matching of the discharge control system to the different tapping rates.

3.3.5 Drain back system

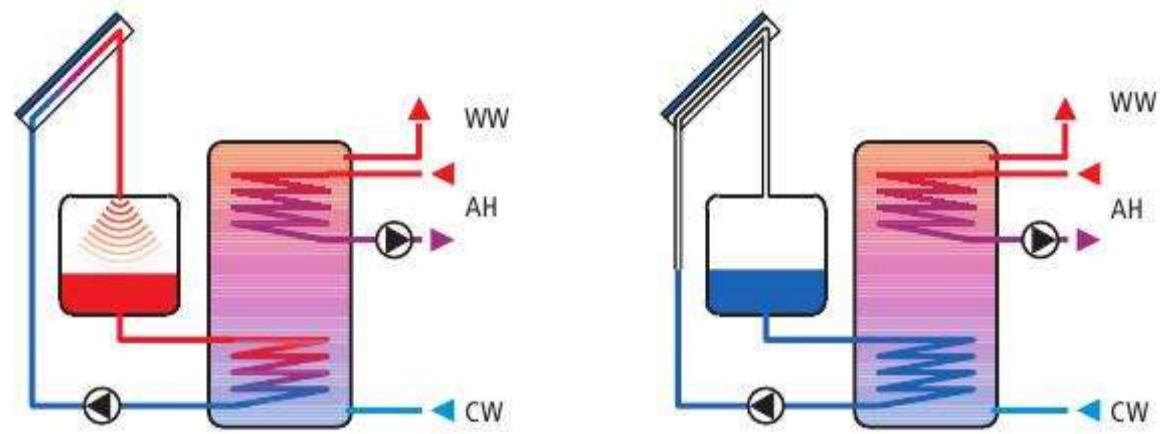

Figure 3.9.

With this system the domestic water heating is carried out, just as with a standard solar system, over the solar circuit heat exchanger. The substantial difference consists of the fact that in a drain back system of the collector, supply- and return-flow pipes drain with a switched off solar circuit pump. The solar liquid is then in a closed receptacle. If required and if solar radiation is sufficient, the pump presses the heat medium into the pipes and collectors and the air into the receptacle. With a drain back systems therefore no frost or evaporation danger exists, so that for the heat distribution water can be used as the medium. A night-time cooling down of the store by force-of-gravity circulation is likewise impossible. In order for such a system to function perfectly, the supply- and return-flow pipes as well as the collectors must run with a necessary downward gradient, so that during filling, all the air from the collectors can be pressed out and when emptying no water remains. This prerequisite is not realizable with every collector product and requires special attention when assembling. At present in the German-speaking countries drain back systems are offered by the following manufacturers: Muntwyler Energietechnik AG, Rotex Heating Systems GmbH, Consolar Solare Energiesysteme GmbH, Wagner & Co., Solartechnik GmbH. In non-German-speaking countries manufacturers are Solene, KingSolar and Flasolar.

3.4 Systems for heating domestic water and space heating

If a solar energy system is considered in the planning stage of the whole heating system, and the house has a central space heating installation, it is possible to use solar heating to augment the space heating (combination systems). The reduced heat requirements of low-energy houses and the higher performance of modern solar energy systems encourage the trend to install solar systems with space heating support.

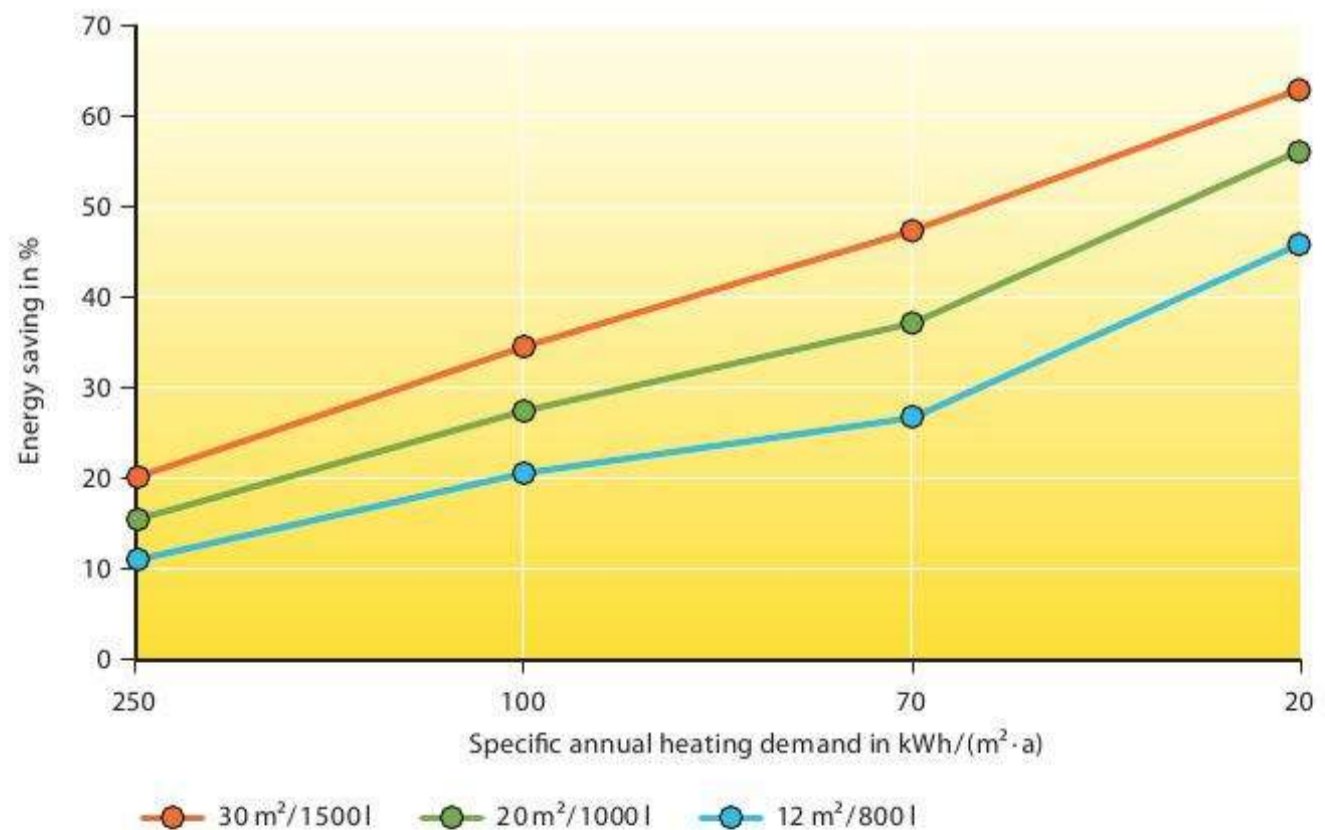

Figure 3.10. Energy saving dependent on the system size and insulation standard (Location Hamburg)

SOLAR FRACTION

Depending upon the yearly amount of heating requirement, the following solar fractions of the total heating demand can be achieved:

- in existing buildings 10–20%;
- in new buildings 20–50%;
- in passive houses > 50% (due to the large proportion of the hot water requirement).

In each case combined systems have a higher primary energy substitution than pure domestic water systems. However as a result of the larger collector surface area an over-sizing of these systems during the heat-free time can occur.

3.4.1 Combined store system (store-in-store system)

See Figure 3.11. A small domestic water store is permanently fitted in the buffer store. The solar circuit is led via an internal heat exchanger, and the auxiliary heating is charged directly into the upper area. The heating circuit draws heating water from halfway up the store and feeds the cooled heating circuit return flow back into the bottom of the buffer store. The cold water that flows back into the domestic water store does, however, impair the heat layers in the event of high draw-off rates. The system requires no expensive control technology. It is mostly found in central Europe, particularly in Switzerland.

3.4.2 System with buffer store, internal heat exchanger for heat removal and downpipe

See Figure 3.12. The store can be charged by the solar circuit via an external heat exchanger at two levels. The corresponding level is selected according to the temperature. Domestic hot water is removed via a special internal heat exchanger, which is fitted above a downpipe. If the heat exchanger cools down because of the inflow of cold water, a downward flow is set up within the pipe and then upwards within the store. In this way the heat exchanger always has sufficient flow rate. The auxiliary heating heats up the upper area of the store. The heating return line is led either to the solar return level via the store or, if the store is too cold, directly to the heating boiler, bypassing the store. The system does not require an expensive control system, but temperature stratification is not optimally achieved.

Figure 3.11 (left).
Combined store system for domestic
water heating and space heating

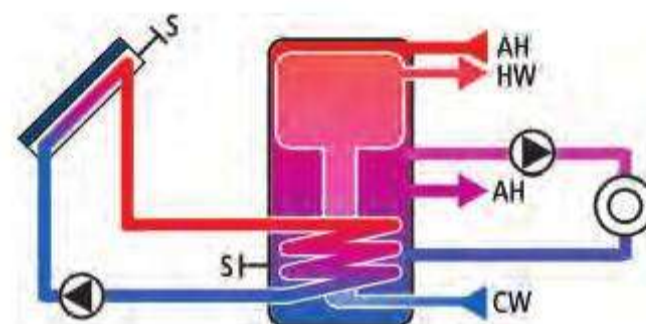
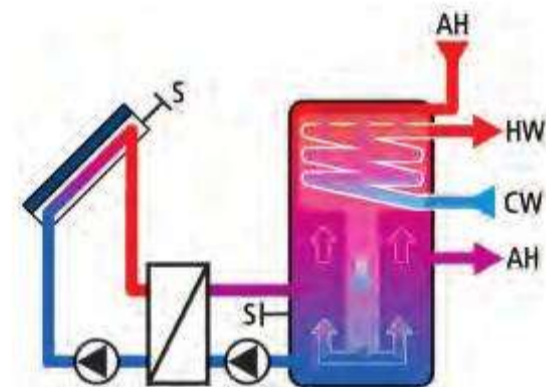

Figure 3.12 (right).
Buffer store system



3.4.3 Stratified store with hot water heating in once-through flow and heating support

Stratified stores, which can be used for heating domestic water only, are also designed for space heating support. The two-layer chargers shown in Figure 3.13 ensure that the solar heat and the heating return pipes, at different temperatures, are brought in at the matching temperature layers of the store. The auxiliary heating takes place in the upper area of the store. Removal of the heat for domestic water heating takes place via an external heat exchanger with a speed-controlled pump. The system operates very efficiently, but special attention must be paid to the control of the discharge pump. For prefabricated systems, however, this does not pose any practical restrictions.

3.4.4 Twin store system

See Figure 3.14. Here we have the classical separation between domestic water and heating buffer stores. The solar circuit charges both stores in the lower area, but the

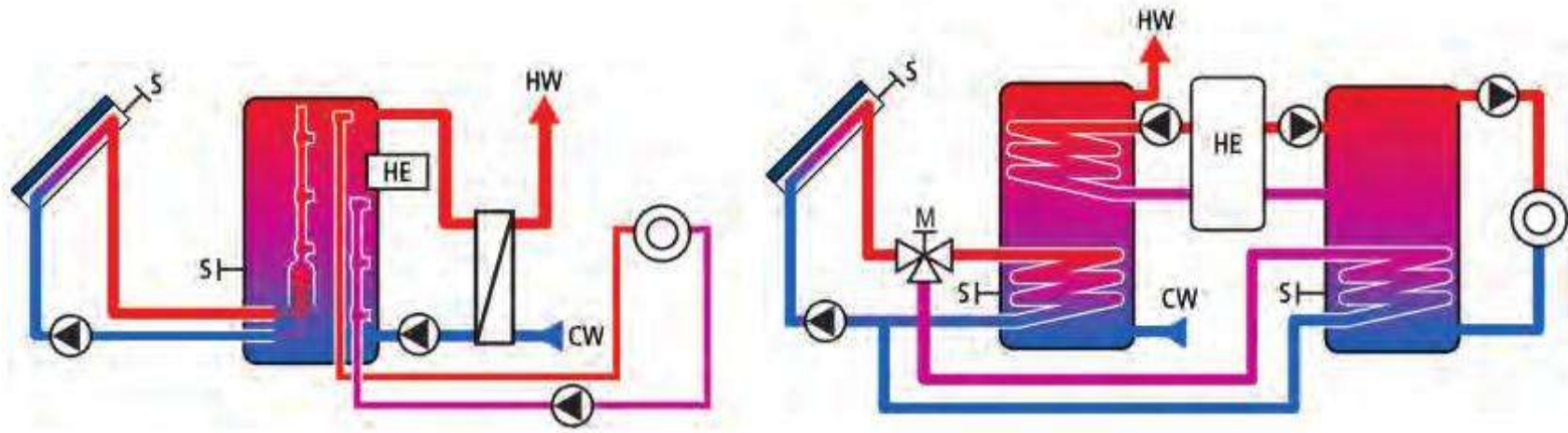

Figure 3.13 (left).
Stratified store system
Figure 3.14 (right).
Twin-store system

domestic water store has the priority. The auxiliary heating charges both stores in the upper area. Each store supplies the system that follows it. This type of system with additional equipment can be used for solar heating support, making use of the existing solar store.

Disadvantages, however, in comparison with the previously mentioned systems are a larger physical space requirement, higher pipework costs and higher store losses.

3.5 Planning and dimensioning

Right at the start of system planning it is important to accurately record the conditions at the site. This includes clarifying all the details that are important for planning and installation, and obtaining data about the building, the hot water consumption and, if necessary, the heat requirement for the house. It is also necessary to sketch all the important details that are required for preparing the quotation.

3.5.1 Important features for preparing the quotation

- Is the collector shaded by trees, parts of the building or other buildings (present/future depending on the time of year; see section 1.1.4)?
- Is the collector temperature sensor shaded?
- What is the most favourable alignment of the collector surface (see Figure 3.15)?
- What is the future accessibility of the collector for maintenance? Access to any chimney must always be guaranteed.
- Do not install collectors beneath aerials and similar equipment, because of bird droppings.
- What is the shortest possible path to the store (< 20 m; 65.6 ft)?
- Are there any requirements with respect to listed buildings?
- Use and complete checklists (see below).
- Is extra equipment required (such as an inclined hoist, or a crane)?
- Are any safety measures necessary (for example safety equipment, safety belts)?
- What type of collector installation is possible/desirable (on-roof, in-roof)?
- Who will install the collector fixing brackets (roofer)?
- Are roof tiles laid in a mortar bed (increased cost of installation)?
- Can the roof be walked on (fragile tiles)?
- Flat roof: bearing load of roof skin (fragile roof)?
- Note minimum distance from mortared ridge tiles.
- What is the best way to fit the piping with good insulation and make the roof penetrations?
- Does central hot water heating already exist?
- How will the solar store be transported to reach its installed location? For example, a 400 l (105.7 gallons) store weighs 145 kg (319.7 lb), is 1.7 m (5.6 ft) high and 0.62 m (2.0 ft) diameter.
- How does the auxiliary heating of the store take place (integration into the existing heating system)?
- How, and by whom, is the electrical work to be done (mains connection, lightning protection/earthing, control system)?
- Is a waste water connection available in the store installation room?

Other hot water requirements: Washing machine Dishwasher

Type of installation: In-roof On-roof Free-standing
 Flat roof Façade/wall/balustrade

Roof covering: Description, type: Colour:

- Tiles
 Stone tiles
 Slates
 Other

Pitch Alignment

Height from ground to eaves:

Usable installation area Height: Width:

Shade:

Height of solar store installation space (m):

Minimum door width (m):

Single length of connecting pipe from store to collector (m):

Work required for connection pipe from store to collector:

Work required for connection pipe from store to hot water distribution:

If store already exists: Type:
 Make:
 Volume: (l)

Heating boiler: Type:
 Make:
 Power (kW):

Circulation line: Yes No

Thermal insulation: Good Poor

Running time of circulation pump: Continuous From To

Only for swimming pool water heating

Pool surface area (m²):

Covered: Yes No

Required water temperature (°C):

Swimming season From: To:

Only for heating support

The living floor area to be heated (m²):

The space heating feed and return flow temperature (°C):

Fuel:

Fuel consumption (l/year, m³/year):

Notes:

Place:

Date:

Filled in by:

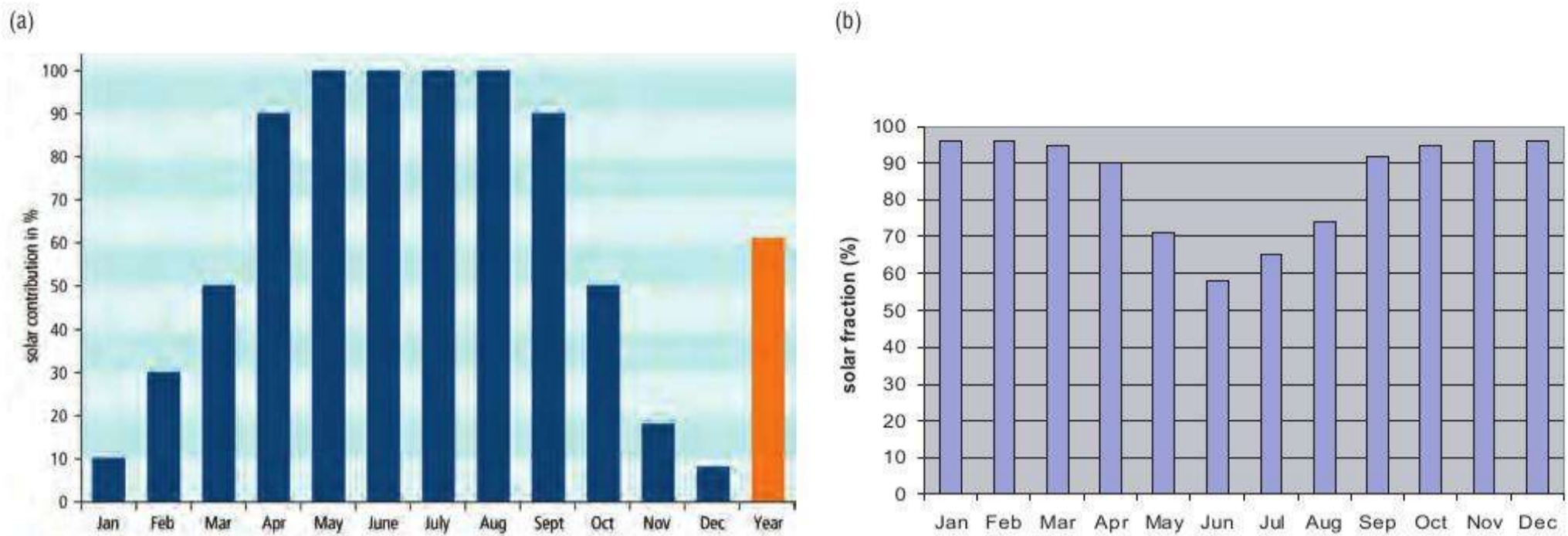

Figure 3.16. Solar fraction for each month for: (a) a system in Northern Europe (55°N), designed to cover the hot water demand fully in the summer months; (b) a system in Sydney, designed to cover 85% of the hot water demand over the year

3.5.2 The dimensioning of systems for domestic water heating

3.5.2.1 DESIGN OBJECTIVES

In temperate climates, a common design objective is that a solar water heater for one-family homes should cover about 90% of the hot water demand during the summer months by means of solar energy. This will have the effect that the heating boiler can remain dormant during most of this period (where drinking water regulations allow this). In this way not only is the environment protected, but also money is saved and the life of the heating boiler is extended.

In the remaining months, when the heating boiler has to operate anyway, the auxiliary heating system supplies the necessary heat not otherwise provided by the sun.

In sunny climates, the common design goal is either to supply the hot water consumption fully from solar energy, or to supply full coverage for most of the year and use a back-up heater (often an electrical element immersed in the solar tank) for only a few weeks or months per year.

3.5.2.2 SOLAR FRACTION

The solar fraction is described as the ratio of solar heat yield to the total energy requirement for hot water heating:

$$SF = \frac{Q_s}{Q_s + Q_{aux}} \times 100$$

where SF is the solar fraction (%), Q_s is the solar heat yield (kWh), and Q_{aux} is the auxiliary heating requirement (kWh). The higher the solar fraction in a solar energy system, the lower the amount of fossil energy required for auxiliary heating: in the extreme case (SF = 100%) none at all.

Figure 3.16a shows the monthly solar fractions for a solar thermal system in a temperate climate. It can be seen that in the case of 100% solar fraction during the radiation-rich months from May to August, an annual fraction of 60% is achieved.

When a system is properly designed, for instance to cover almost the complete demand in the summer months in central Europe, the addition of extra collector areas would not lead to correspondingly higher output. In periods with high irradiation, the system would produce excess heat, which would lead not only to frequent high thermal loads on the collectors (stagnation), but also to a lower efficiency (additional costs are higher than additional yield). In periods with lower irradiation, the output would be higher but the total annual output per square metre of collector would be lower than with the original system.

In systems with an auxiliary heat exchanger inside the same tank as the solar-heated water, the tank heat losses result from both the solar heat and the auxiliary heat brought into the tank. Depending on how the heat losses from the tank are attributed to the solar heat and/or the auxiliary heat, the solar fraction may then be defined in different ways.

3.5.2.3 SYSTEM EFFICIENCY

The system efficiency gives the ratio of solar heat yield to the global solar irradiance on the absorber surface with respect to a given period of time, for example one year:

$$SE = \frac{\dot{Q}_s}{E_G A} \times 100$$

where SE is the system efficiency (%), \dot{Q}_s is the solar heat yield (kWh/a), E_G is the total yearly solar irradiance (kWh/m²a), and A is the absorber surface area (m²).

If the absorber surface area and the irradiance are known, and if the solar heat yield is measured (heat meter), the system efficiency can be determined:

Example:

$$A = 6 \text{ m}^2$$

$$E_G = 1000 \text{ kWh/m}^2\text{a (central Europe)}$$

$$\dot{Q}_s = 2100 \text{ kWh/a}$$

Then the system efficiency is given by

$$SE = \frac{2100 \text{ kWh} \times \text{m}^2 \times \text{a}}{1000 \text{ kWh} \times \text{a} \times 6\text{m}^2} \times 100 = 35\%$$

The system efficiency is strongly dependent on the solar fraction. It is higher at lower solar fractions (when the solar water heater size is small compared with the hot water demand). If the solar fraction is increased by increasing the collector area, the system efficiency is reduced, and every further kilowatt-hour that is gained becomes more expensive. This counter-effect of the two variables can be seen in Figure 3.17.

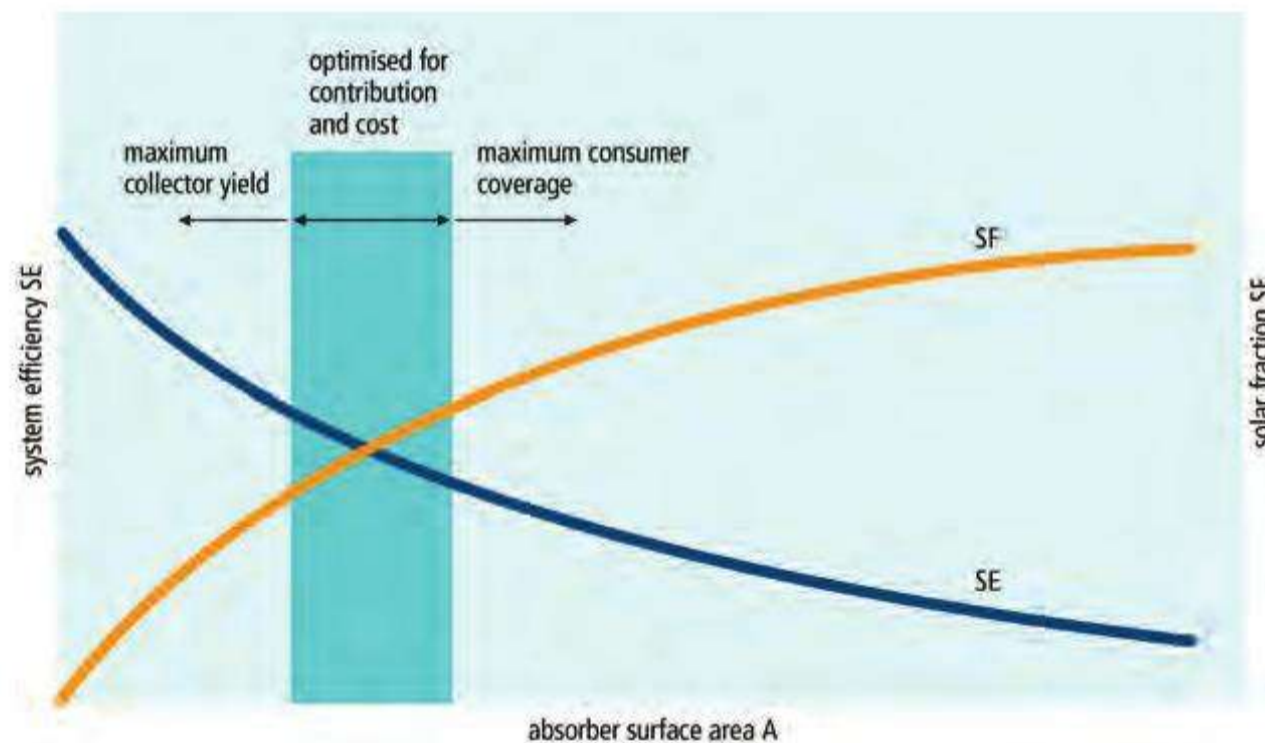

Figure 3.17.
Solar fraction and system efficiency¹⁷

3.5.2.4 STEP 1: DETERMINATION OF HOT WATER CONSUMPTION

The hot water consumption, V_{HW} , of those living in the house is a key variable for system planning, and if it cannot be measured, it should be estimated as closely as possible. When determining the requirements, a check should be made on the possibilities of saving domestic water (for example by the use of water- and energy-saving fittings). A lower water consumption means a smaller solar energy system and hence a lower investment.

However, it is not possible to estimate the hot water consumption of a household accurately, as individual differences are enormous. Of two similar families living in two identical neighbouring houses, one family might use twice as much hot water as the other. For large solar installations, the hot water consumption may be measured separately before designing a solar water heating installation.

During the design of solar energy systems for one- and two-family houses, the following average values can be used for estimating the hot water consumption:¹⁸

1 × hand washing (40°C; 104°F)	3 l (0.8 gallons)
1 × showering (40°C; 104°F)	35 l (9.3 gallons)
1 × bathing (40°C; 104°F)	120 l (31.7 gallons)
1 × hair washing	9 l (2.4 gallons)
Cleaning	3 l (0.8 gallons) per person per day
Cooking	2 l (0.5 gallons) per person per day
1 × dishwashing (50°C; 122°F)	20 l (5.3 gallons)
1 × washing machine (50°C; 122°F)	30 l (7.9 gallons)

Depending on the fittings in the household, the following average consumption values per person per day can be calculated (usage temperature of hot water approximately 45°C; 113°F):

■ low consumption	20–30 l (5–8 gallons)
■ average consumption	30–50 l (8–13 gallons)
■ high consumption	50–70 l (13–18 gallons)

In the following, all the components for a thermal solar energy system for heating the domestic water for a four-person household in the UK will be dimensioned: collector surface area, domestic water store volume, solar circuit pipework, heat exchanger, circulating pump, expansion vessel and safety valve.

We assume an average hot water consumption of 50 l (13 gallons) per person per day (45°C; 113°F), and a requirement to supply the dishwasher and the washing machine with solar-heated water (either special machines or by using an adapter; see Chapter 2 section 2.3.6 on this subject). According to the information from the user the dishwasher and washing machine operate on average twice per week.*

Taking into account the different hot water temperatures, the daily hot water consumption is then calculated as follows:

$$V_{\text{HW}} = 4 \text{ persons} \times 50 \text{ l (45°C)} + 16 \text{ l (45°C)} = 216 \text{ l (45°C)} \text{ per day}$$

3.5.2.5 STEP 2: HOT WATER HEAT REQUIREMENT

The heat requirement, Q_{HW} , can be determined from the hot water consumption according to the following equation:

$$Q_{\text{HW}} = V_{\text{HW}} c_w \Delta\theta$$

where V_{HW} is the average hot water quantity (l or kg), c_w is the specific heat capacity of water (= 1.16 Wh/kgK), and $\Delta\theta$ is the temperature difference between hot and cold water (K).

In our example the necessary daily heat requirement for heating 216 l of water from 10°C (we assume this to be the cold water temperature for this example) to 45°C is given by:

$$\begin{aligned} Q_{\text{HW}} &= 216 \text{ kg} \times 1.16 \text{ Wh/kg K} \times (45 - 10) \text{ K} \\ &= 8770 \text{ Wh} \\ &= 8.77 \text{ kWh per day} \end{aligned}$$

Note that, depending on the domestic/drinking water regulations, the actual temperature of the hot water delivered should in some countries be higher, for instance 60°C (140°F). In such cases, the water will be mixed at the tapping point. The hot water supply system will have to deliver a smaller amount of water at the high temperature, which will however have the same energy content. This amount is calculated as follows:

$$V_{\theta_2} = \frac{\theta_1 - \theta_c}{\theta_2 - \theta_c} \times V_{\theta_1}$$

* $2 \times 20 \text{ l (50°C)} + 2 \times 30 \text{ l (50°C)} / 7 \text{ days} \approx 16 \text{ l (45°C)}$ for dishwashing and the washing machine per day.

where θ_1 is the old temperature level, θ_2 is the new temperature level, θ_c is the cold water temperature, V_{θ_1} is the volume of water at the old temperature level, and V_{θ_2} is the volume of water at the new temperature level.

For example, the amount of water at 60°C (140°F) equivalent to the above-mentioned 216 l (57 gallons) at 45°C (113°F), using a cold water temperature of 10°C (50°F), is calculated as follows:

$$V_{60} = \frac{45 - 10}{60 - 10} \times 216 = 151 \text{ l}$$

HEAT LOSSES IN PIPING AND STORES

The significance of thermal insulation is often underestimated. In the following, estimates are made of the possible thermal losses from the solar circuit, the circulation lines and the solar store.

HEAT LOSSES IN INSULATED PIPES

It is possible to make a relatively good estimate of the losses if we consider only the heat conduction through the thermal insulation.¹⁹

The heat losses can be formulated as follows:

$$Q_{\text{pipe}} = \frac{2\pi\lambda\Delta\theta}{\ln(D_{\text{wd}}/D_{\text{pipe}})} \quad (\text{W/m})$$

where λ is the thermal conductivity of the insulating material (W/mK), D_{wd} is the outside dimension of the insulated pipe (mm), D_{pipe} is the outside diameter of the pipe (mm), \ln is natural logarithm, and $\Delta\theta$ is the difference between the temperature in the pipe, θ_{pipe} , and the ambient air temperature, θ_{air} (K).

Example:

$$\lambda = 0.04 \text{ W/mK (mineral wool)}$$

$$D_{\text{wd}} = 54 \text{ mm}$$

$$D_{\text{pipe}} = 18 \text{ mm}$$

$$\Delta\theta = 30 \text{ K}$$

In this way Q_{pipe} is calculated as

$$Q_{\text{pipe}} = \frac{2\pi \times 0.04 \text{ W} \times 30 \text{ K}}{\ln(54 \text{ mm}/18 \text{ mm})\text{mK}} = 6.9 \text{ W/m}$$

With a total solar circuit length of 20 m and approximately 2000 operating hours per annum, heat losses of $\dot{Q}_{\text{pipe}} = 6.9 \text{ W/m} \times 20 \text{ m} \times 2000 \text{ h/a} = 276 \text{ kWh/a}$. This corresponds to an approximate annual yield for a solar energy plant with 5 m² of glazed flat-plate collectors of 15% ($\dot{Q}_s = 5 \text{ m}^2 \times 1000 \text{ kWh/m}^2\text{a} \times 0.35 = 1750 \text{ kWh/a}$).

If a circulation pipe is installed in the building, additional heat losses or an increased heat requirement will have to be allowed for. With a circulation line of 15 m and a running time for the circulation pumps of 2 h per day the following heat losses can be calculated:

$$\dot{Q}_{\text{circ}} = 6.9 \text{ W/m} \times 15 \text{ m} \times 2 \text{ h/day} \approx 76 \text{ kWh/a}$$

Therefore the resulting heat losses Q_G are

$$\begin{aligned} \dot{Q}_G &= \dot{Q}_{\text{pipe}} + \dot{Q}_{\text{circ}} \\ &= 276 \text{ kWh/a} + 76 \text{ kWh/a} \\ &= 352 \text{ kWh/a} \end{aligned}$$

This corresponds to an annual heat gain for 1 m² of glazed flat-plate collector surface area.

HEAT LOSSES FROM NON-INSULATED PIPES

It is also possible to estimate the heat losses for non-insulated pipes. However, as very complicated relationships exist here between convection and heat radiation, a calculation is offered for simplification purposes that uses a very much simplified equation using factors.¹⁹ This is valid only for piping diameters below 100 mm and air temperatures around the pipes of $\theta_A = 20^\circ\text{C}$:

$$\dot{Q}_{\text{pipe}} = D_{\text{pipe}} (29.85 + 0.027\theta_{\text{pipe}}^3 \sqrt{\theta_{\text{pipe}}}) \Delta\theta \quad (\text{W/m})$$

The pipe diameter must be inserted here in m.

Example:

$$D_{\text{pipe}} = 0.018 \text{ m}$$

$$\theta_{\text{pipe}} = 50^\circ\text{C}$$

$$\Delta\theta = 30 \text{ K}$$

$$\dot{Q}_R = 0.018 \text{ m}(29.85 + 0.027 \times 50^\circ\text{C}^3 \sqrt{50^\circ\text{C}}) \times 30\text{K} \approx 19 \text{ W/m}$$

Therefore, when the solar circuit is not thermally insulated, heat losses arise that are almost three times higher than those for insulated piping. These heat losses will be comparable to the yield of several square metres of solar collectors, and will greatly reduce the yield of the solar system.

HEAT LOSSES FROM STORES

The heat losses from a solar store increase in proportion to the area of its upper area, A , and the temperature difference between the store and the surroundings, $\Delta\theta$:

$$\dot{Q}_{\text{St}} \approx A\Delta\theta$$

With the help of the heat loss coefficient k in $\text{W/m}^2\text{K}$, the following equation is derived:

$$\dot{Q}_{\text{St}} = kA\Delta\theta \text{ (W)}$$

For stores the kA value is normally given in W/K .

Example:

$$kA \text{ value} = 1.6 \text{ W/K}$$

$$\Delta\theta = 30 \text{ K}$$

$$\dot{Q}_{\text{St}} = 1.6 \text{ W/K} \times 30 \text{ K} = 48 \text{ W}$$

Over the course of a year this store has heat losses of

$$\dot{Q}_{\text{St}} = 48 \text{ W} \times 24 \text{ h/d} \times 365 \text{ days/a} \approx 420 \text{ kWh/a}$$

In the above case the heat losses in the store thereby correspond with the solar gain of about 1.2 m^2 of collector surface.

3.5.2.6 STEP 3: DESIGN AND DIMENSIONING OF SYSTEM COMPONENTS

There are four different methods:

- rough determination of size with an approximation formula
- detailed calculation of the individual components
- graphical design with nomographs
- computer-aided design with simulation programs.

ROUGH DETERMINATION OF SIZE WITH AN APPROXIMATION FORMULA

COLLECTOR SURFACE AREA

For a system designed for a *temperate climate*, a rough estimate for the essential system components can be made under the following assumptions:

- Average hot water requirement, $V_{\text{HW}} = 35\text{--}65$ litres (9.3–17.2 gallons) (45°C ; 113°F) per person per day.
- Yearly average solar fraction = approximately 60% (covering almost the complete hot water demand in the summer months).
- Collector at optimal or almost optimal orientation and tilt angle (see section 1.1.3).
- No or little shading.
- Design goal is to cover the load almost completely in the months with high irradiation.

The rule of thumb for such situations is:

1–1.5 m^2 (10.8–16.2 ft^2) of glazed flat-plate collector area per person ($E_G = 1000 \text{ kWh/m}^2\text{a}$)
 0.7–1 m^2 (7.5–10.8 ft^2) of evacuated tube collector surface per person ($E_G = 1000 \text{ kWh/m}^2\text{a}$)

In our example this approximation formula leads to a required glazed flat-plate collector surface area of 4–6 m² (43–64.6 ft²).

For different irradiation levels (see Chapter 1), these values may be scaled. For instance, when the irradiance is 1300 kWh/m²a, the collector area may be 1.3 times smaller.

For a *tropical climate*, the collector area can be estimated under the following assumptions:

- Average hot water requirement, $V_{HW} = 35\text{--}65$ litres (9.3–17.2 gallons) (45°C; 113°F) per person per day.
- Favourable solar irradiance conditions.
- Yearly average solar fraction = approximately 80% (auxiliary heating is necessary only in a few months).
- Collector at optimal or almost optimal orientation and tilt angle (see section 1.1.3).
- No or little shading.

The rule of thumb for such situations is:

0.35–0.6 m² (3.8–6.5 ft²) of glazed flat-plate collector area per person ($E_G = 2000$ kWh/m²a)

In our example this approximation formula leads to a required glazed flat-plate collector surface area of 1.4–2.4 m².

For different irradiation levels (see Chapter 1), these values may be scaled. For instance, when the irradiance is 1700 kWh/m²a, the collector area must be 1.2 times larger.

DOMESTIC WATER STORE VOLUMES AND HEAT EXCHANGERS

In general, in order to bridge over a few sunless days without any auxiliary heating, the store volume should be designed to be 1–2 times the daily hot water consumption. In our example of a consumption of 216 l (57 gallons) per day, this leads to a store volume of 200–400 l (52.8–105.7 gallons). For the dimensioning of internal heat exchangers the following approximation formulae apply:

- Finned tube heat exchanger: 0.35 m² exchanger surface area per m² of collector surface area.
- Plain tube heat exchanger: 0.20 m² exchanger surface area per m² of collector surface area.

For our example this means that, in the selection of a store with a built-in plain tube heat exchanger, it should have a surface area of about 0.8–1.2 m² (4–6 × 0.2 m²).

SOLAR CIRCUIT PIPES, CIRCULATING PUMPS AND EXPANSION VESSEL

From Table 3.1, the pipe diameters for the solar circuit can be established depending on the collector surface area and the length of the pipes. These values are valid for pumped systems. The matching size for the circulating pump is also given. For thermosyphon systems, larger diameters and/or shorter lengths will probably be required to ensure proper flow; for low-flow systems the diameters and pump powers can be much lower.

Table 3.1.
Solar circuit pipe diameter in
relation to collector surface area and
length of solar circuit pipes²⁰

Collector surface area (m ²)	Total length (m)				
	10	20	30	40	50
Up to 5	15/I	15/I	15/I	15/I	15/I
6–12	18/I	18/I	18/I	18/I	18/I
13–16	18/I	22/I	22/I	22/I	22/I
17–20	22/I	22/I	22/I	22/I	22/I
21–25	22/I	22/II	22/II	22/II	22/III
26–30	22/II	22/II	22/III	22/III	22/III

The Roman characters identify the respective circulation pumps. I = 30–60 W power consumption. II, III = 45–90 W.

Example:

For a pumped, high-flow system with a collector surface area of 6 m² (64.6 ft²) and a total length of feed and return pipes of 20 m (65.6 feet), a solar circuit pipe diameter of 18 mm (0.71 inches) is obtained, and a corresponding circulating pump with a power between 30 and 60 W.

When the collector is filled with antifreeze fluid and it is allowed to boil dry in overheating situations, there must be an expansion vessel of sufficient size to contain the displaced collector fluid. The volume of the expansion vessel can be obtained from Table 3.2: it depends on the collector surface area and the system height between the expansion vessel and the edge of the collector.

Table 3.2.
Design of expansion vessel volume for a safe stagnation temperature in relation to collector surface area and system height²¹

System volume (l)	Collector surface area (m ²)	System height (m)					
		2.5	5	7.5	10	12.5	15
18	5	12	12	12	12	18	18
20	7.5	12	12	12	18	25	35
23	10	12	12	18	25	35	35
24	12.5	12	18	25	35	35	35
25	15	18	25	35	35	35	50
29	17.5	25	35	35	35	50	50
35	20	25	35	35	50	50	50
37	25	35	35	50	50	50	80
40	30	35	50	50	50	80	80

The table does not take into account the vapour volumes that can occur in the collector connecting lines in evacuated tube collector systems under certain circumstances.

From the table an expansion vessel volume of 12 l (3.17 gallons) can be obtained for our example.

DETAILED CALCULATION OF THE INDIVIDUAL COMPONENTS

For this design method the components of a thermal solar energy system are calculated on the basis of the general conditions given.

COLLECTOR SURFACE AREA

Starting from a calculated heat requirement, taking into account the solar radiation, an average system efficiency and a desired solar fraction, the required collector or absorber surface area is calculated as follows.

Calculated heat requirement, $\dot{Q}_{HW} = 8.77$ kWh per day

Yearly solar radiation, $E_G = 1000$ kWh/m²/year (central European climate)

Average system efficiency, $\eta_{sys} = 0.35$ [‡]

Desired solar fraction, SF = 60% for temperate climates, 80% for tropical climates

$$\text{Absorber surface} = \frac{365 \text{ days} \times 8.77 \text{ kWh per day} \times 0.6}{1000 \text{ kWh/m}^2\text{a} \times 0.35}$$

$$\approx 5.5 \text{ m}^2 (59.2 \text{ ft}^2) \text{ for temperate climates}$$

SOLAR CIRCUIT PIPE DIAMETER

A special factor that has an effect on heat transfer in the solar circuit is the *pressure loss*. This should be kept as low as possible. In doing so it is important to ensure that the speed of flow does not exceed the value of 0.7–1 m/s (2.3–3.3 ft/s), as otherwise the flow resistance of the pipe would be too high. For flow speeds higher than 0.7 m/s (2.3 ft/s) there may be additional noise nuisance, and from 1 m/s (3.3 ft/s) there may even be material abrasion within copper tubes. On the other hand a given volumetric flow must be available for transporting the heat from the collector to the store. For the volumetric flow in the solar circuit, experience has shown that a value of about 40 l/hour (10.6 gallons/hour) for each m² of collector area is ideal for high-flow systems.

^{*}Solar irradiance at $\alpha = 45^\circ$ and $\beta = 40^\circ$.

[‡]Average system efficiency for a glazed flat-plate collector system taking account of collector, line and store losses. Note: This efficiency is dependent on the solar fraction (see section 3.5.2.3).

CALCULATION OF VOLUMETRIC FLOW AND PIPE CROSS-SECTION IN A SOLAR CIRCUIT

During system operation the volumetric flow should be large enough to cool the collector sufficiently (low average absorber temperature leads to good collector efficiency). On the other hand the flow rate through the collector should not be so large that it cannot generate a usable flow temperature. For calculating the optimum volumetric flow we make the assumption that a restriction of the temperature difference between the feed and return flows to 10 K – even in the event of good insolation – is sensible for the reasons mentioned above. The volumetric flow can then be calculated with the help of the following equation:

$$\dot{m} = \frac{\dot{Q}}{c_{G/W} \Delta \theta}$$

where \dot{Q} is the usable thermal output converted by the collector (W/m^2), $c_{G/W}$ is the specific heat capacity of the solar liquid = 1.03 Wh/kg K, and $\Delta \theta$ is the temperature difference between the feed and return flows (= 10 K).

Example:

Irradiance = 800 W/m^2

Collector efficiency = 50%

$$\begin{aligned} \dot{m} &= \frac{400 \text{ W/m}^2}{1.03 \text{ Wh/kg K}} \times 10 \text{ K} \\ &= 39 \text{ kg/m}^2\text{h} \text{ (8 lb/ft}^2\text{h)} \\ &= 40 \text{ l/m}^2\text{h} \text{ (1 gallon/ft}^2\text{h)} \end{aligned}$$

The solar circuit pipe diameter can be calculated from the variables, volumetric flow \dot{m} and flow speed v :

$$D = \sqrt{\frac{4 \dot{m}}{\pi v}}$$

Example:

Volumetric flow, $\dot{m} = 240 \text{ l/h}$ ($6 \text{ m}^2 \times 40 \text{ l/m}^2\text{h}$)

Flow speed, $v = 0.7 \text{ m/s}$

$$\begin{aligned} D &= \sqrt{\frac{4 \frac{240 \text{ l}}{\text{h}}}{0.7 \text{ m/s}}} \\ &= \sqrt{\frac{4 \frac{240 \text{ dm}^3}{\text{h}}}{25,200 \text{ dm/s}}} \\ &= \sqrt{\frac{4}{3.1416}} \\ &= \sqrt{0.0121 \text{ dm}^2} = 0.1101 \text{ dm} = 11.01 \text{ mm} \end{aligned}$$

The required internal diameter should therefore be at least 11 mm (0.4 inches). On the basis of Table 3.3 a copper pipe with an internal diameter of 13 mm (0.5 inches) would be selected (description Cu 15 × 1).

Table 3.3
Dimensions of standard copper pipes

Pipe dimensions (outside dia. × wall thickness)	Internal dia. (mm)	Contents (l/m)
Cu 10 × 1	8	0.05
Cu 12 × 1	10	0.079
Cu 15 × 1 DN 12	13	0.133
Cu 18 × 1 DN 15	16	0.201
Cu 22 × 1 DN 20	20	0.314
Cu 28 × 1.5 DN 25	25	0.491

Note: not all diameters are on the market in all countries.

An examination of temperature-dependent length changes in pipes can be found in Chapter 4, section 4.1.7.

CIRCULATING PUMPS

In general, traditional circulating pumps with three to four control stages are sufficient for small systems (collector surface areas $\leq 20 \text{ m}^2$ (215.3 ft^2)). For detailed design it is necessary to know the overall pressure loss, Δp_{tot} , in the solar system. This is made up of the pressure losses in the collector, in the solar circuit and in the heat exchanger:

$$\Delta p_{\text{tot}} = \Delta p_{\text{col}} + \Delta p_{\text{solar circ}} + \Delta p_{\text{heat exch}}$$

The pressure loss in the collector, Δp_{col} , is dependent on the design, on the selected volumetric flow, and on the type of collector connection. The pressure loss of the individual collectors, which depends on the volumetric flow, can be found in the manufacturer's information (see Figure 3.18). If several collectors are connected in parallel the pressure of the collector field corresponds to that of one collector. If they are connected in series the individual pressure losses are added together.

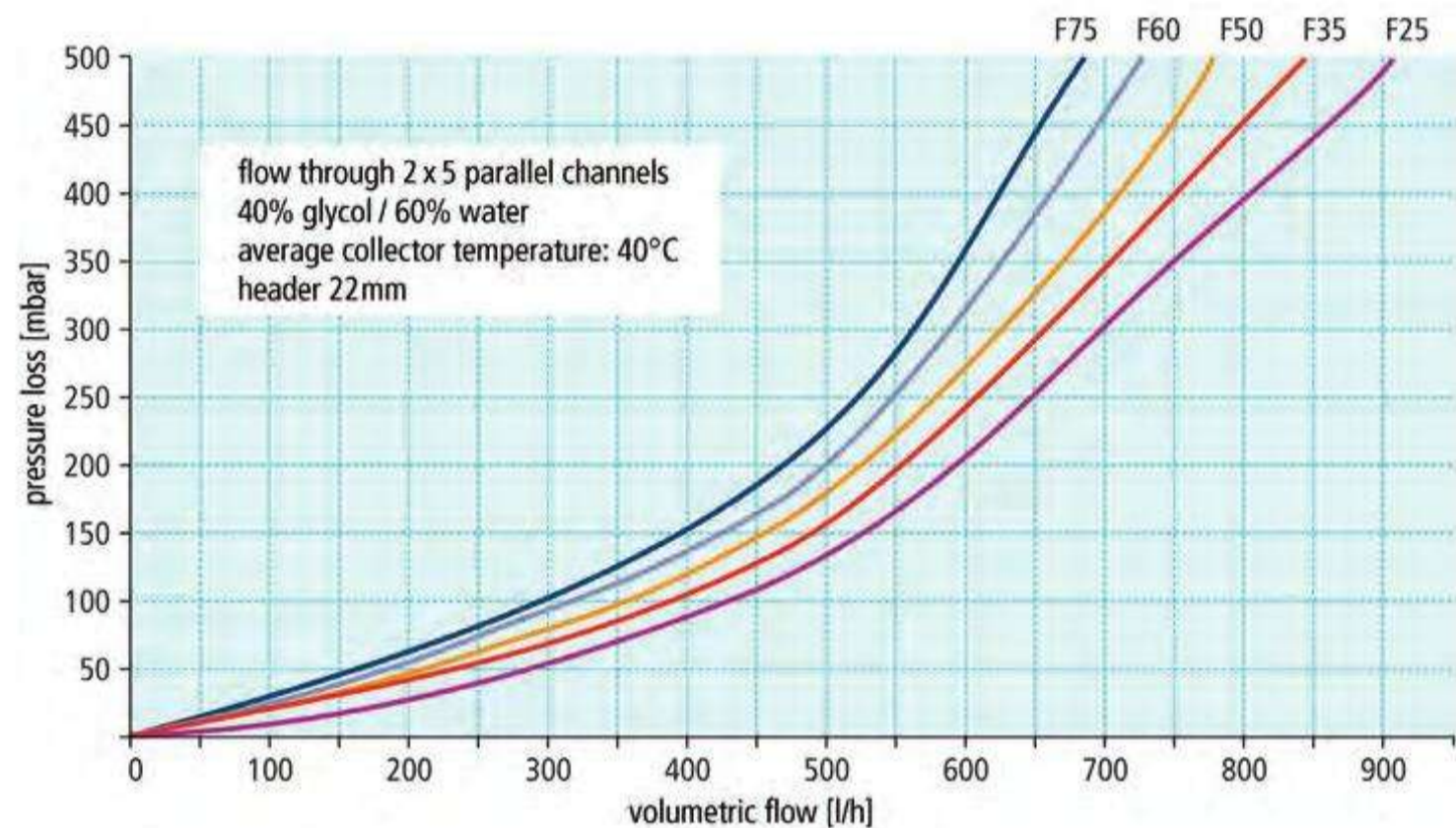

Figure 3.18.
Example of pressure loss curves for five
glazed flat-plate collectors
Source: SOLVIS Energiesysteme,
Braunschweig

Example:

On the basis of the calculated collector surface area of 5.5 m^2 (59.2 ft^2), the collector with the middle pressure loss curve (a model with an aperture area of 5.08 m^2 (54.7 ft^2)) is selected. With a volumetric flow of $40 \text{ l/m}^2\text{h}$ (0.98 gallons/ ft^2h) we obtain from Figure 3.18:

$$\Delta p_{\text{col}} = 50 \text{ mbar (0.73 psi)}$$

The pressure loss of the solar circuit, $\Delta p_{\text{solar circ}}$, is made up of the pressure loss in the piping, Δp_{piping} , and the sum of the pressure losses in the fittings, $\Delta p_{\text{fittings}}$.

The specific pressure loss per metre of installed pipe length is dependent on the pipe cross-section and the flow speed, and can be established by nomographs. In doing this the pipe material that is used, and the concentration of the water-glycol mixture, must be taken into account. The pressure losses in bends, T-pieces, screwed connections, valves and fittings are taken from the respective tables in the form of pressure loss correction values, or they can be estimated as an overall one third of the piping losses.

Example:

At a volumetric flow of 200 l/h ($\approx 5.08 \text{ m}^2 \times 40 \text{ l/m}^2\text{h}$) the pressure loss for DN 12 (= Cu 15 \times 1) from Figure 3.19 is

$$\begin{aligned} \Delta p_{\text{solar circ}} &= 4.5 \text{ mbar per metre of line length} \times 20 \text{ m} \\ &= 90 \text{ mbar} \end{aligned}$$

$$\begin{aligned} \Delta p_{\text{fittings}} &= 1/3 \Delta p_{\text{solar circ}} \\ &= 30 \text{ mbar} \end{aligned}$$

The pressure loss in the solar circuit heat exchanger, $\Delta p_{\text{heat exch}}$, can be found in the product documentation according to the type of heat exchanger and the flow speed.

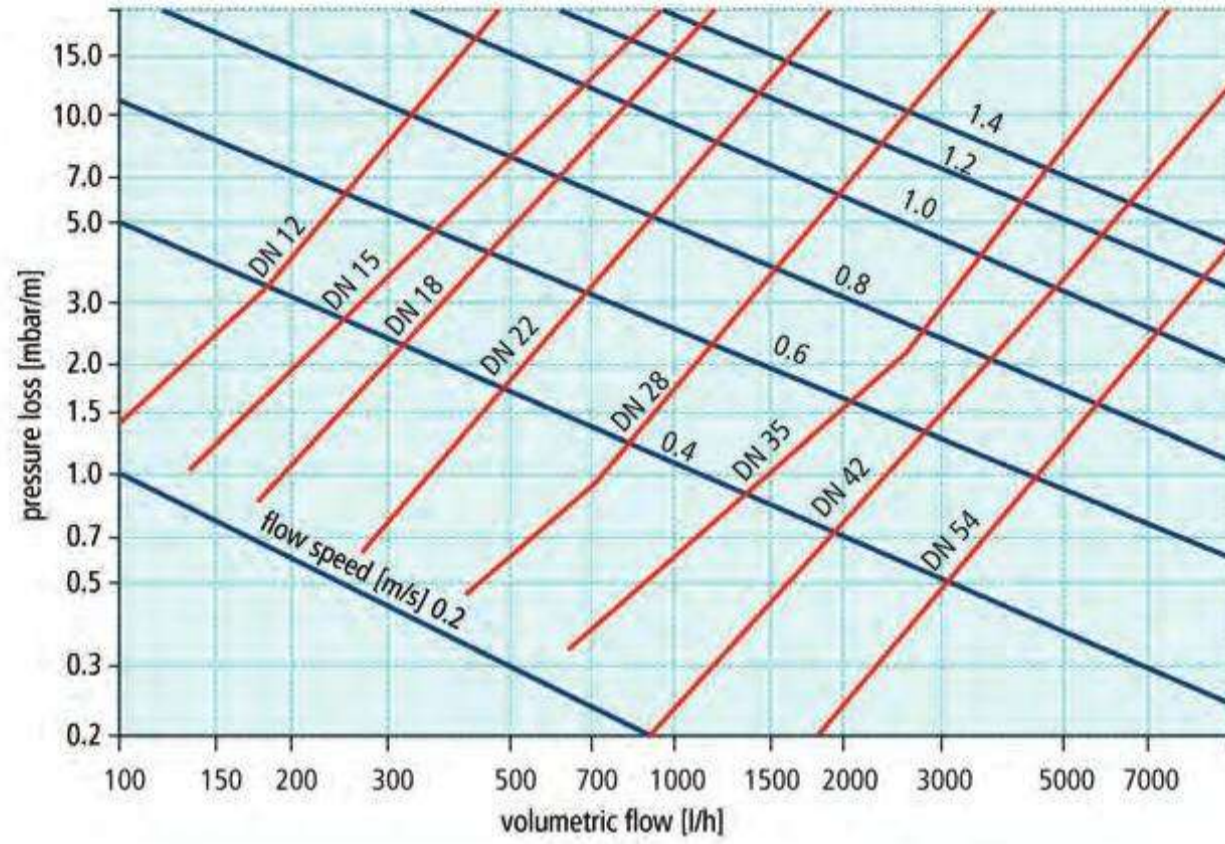

Figure 3.19. Pipe network characteristics for copper, 35% glycol, 65% water, 50°C²²

Example:

With a volumetric flow of 200 l/h for the plain tube heat exchanger corresponding to the lowest line in the graph (Figure 3.20), with a heat exchanger surface area of 0.2 m² per m² of collector surface area, and a 5.08 m² collector, we obtain a pressure loss of

$$\Delta p_{\text{heat exch}} = 2 \text{ mbar}$$

We thus obtain for the total pressure loss of the system, at a volumetric flow of 200 l/h,

$$\Delta p_{\text{tot}} = 50 \text{ mbar} + 90 \text{ mbar} + 30 \text{ mbar} + 2 \text{ mbar} = 172 \text{ mbar}$$

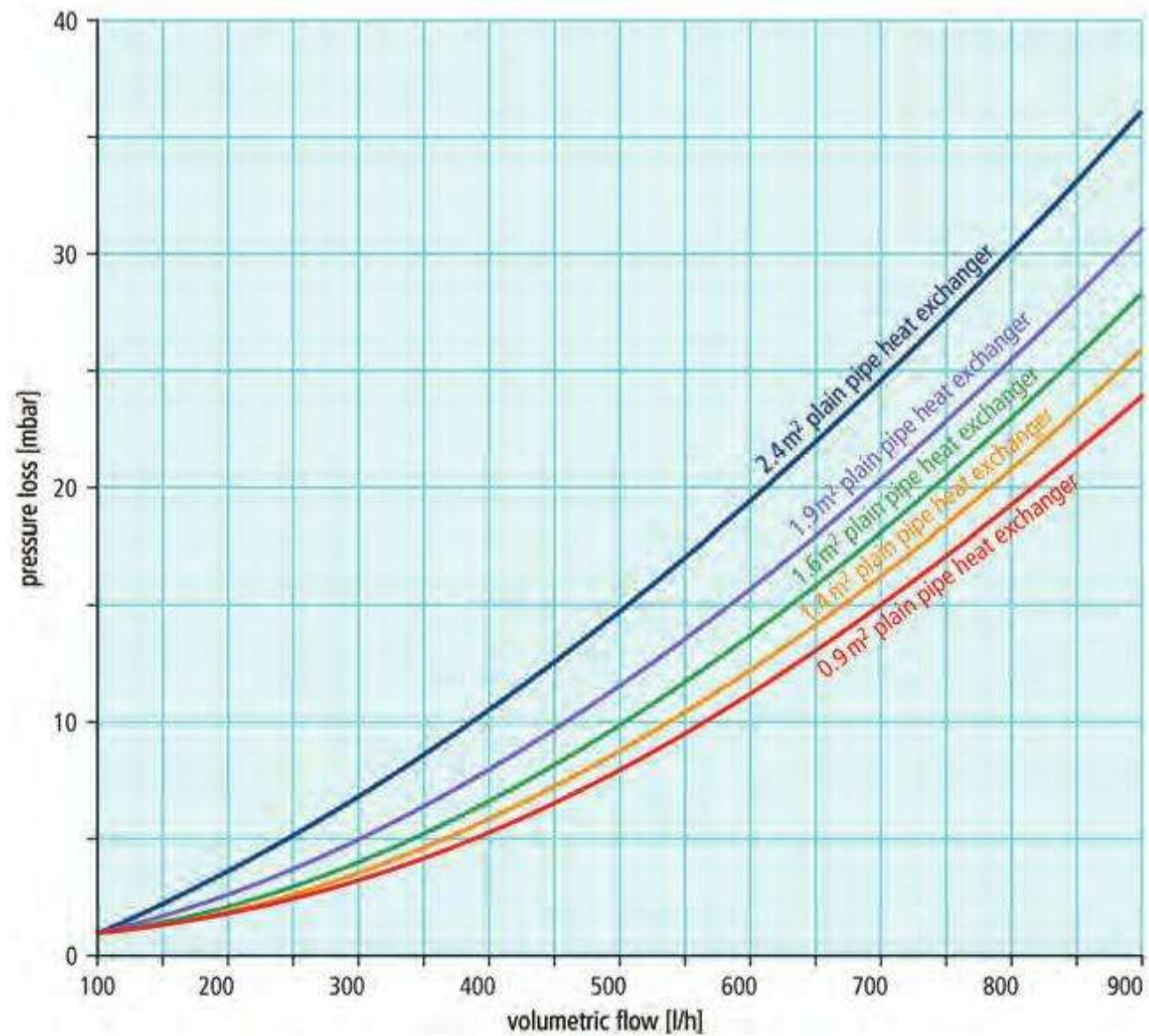

Figure 3.20. Pressure losses of plain tube heat exchangers²³

For the selection of a suitable pump in the solar circuit the pressure loss characteristics of the system must first be established. For this purpose the total pressure losses for different volumetric flows are calculated from the determined pressure loss at the given volumetric flow according to the equation

$$\frac{v_1^2}{v_2^2} = \frac{p_1}{p_2}$$

Example:

$$v_1 = 200 \text{ l/h}, p_1 = 172 \text{ mbar}, v_2 = 500 \text{ l/h}$$

$$p_2 = \frac{(500 \text{ l/h})^2}{(200 \text{ l/h})^2} \times 172 \text{ mbar} = 1,075 \text{ mbar}$$

Table 3.4.
Coordinates of system
characteristics

v (l/h)	0	200	500	1000
p (mbar)	0	172	1075	4300

The pressure loss characteristics of the system can then be entered into the manufacturer's pump diagram (Figure 3.21). The intersecting points of the system characteristic lines with the pump characteristic lines at the different power settings give the possible working points. These working points should lie in the middle of the pump characteristic lines if possible, as it is here that the pump operates at its maximum efficiency, and an increase or reduction of the flow is possible by means of the control settings of the pump.

EXPANSION VESSEL AND SAFETY VALVE (SV)

The significance of the membrane expansion vessel for the system safety of filled systems has already been described (see Chapter 2, section 2.4.8.2). (Note that for drainback systems, or systems where the collector fluid is not allowed to boil dry in the collector, an expansion vessel is not needed or may be much smaller.)

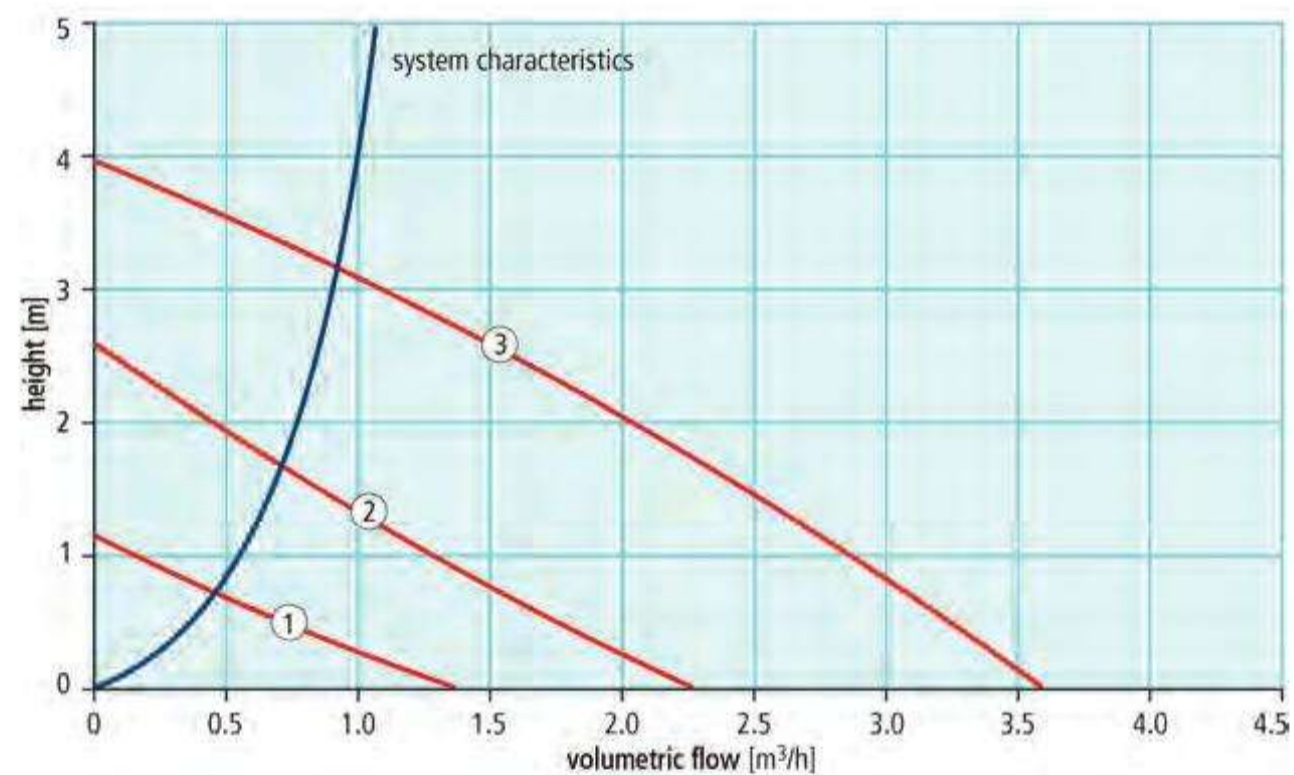

Figure 3.21.
Pump characteristics and system
pressure loss characteristics. Source:
Wilo, Dortmund

For calculation of the size of the vessel, apart from the temperature-related volume changes of the solar liquid, the fluid channels volume of the collector should also be considered to allow the collectors to boil dry in the event of system stagnation.

The minimum vessel size is calculated according to the following equation:

$$V_{\text{MEVmin}} = V_D \frac{p_{\text{Bmax}} + 1}{p_{\text{Bmax}} - p_{\text{in}}}$$

where V_D is the expansion volume (l), p_{Bmax} is the maximum permissible operating pressure (bar), and p_{in} is the initial (working) pressure with which the system is filled (bar).

The quotient

$$\frac{1}{(p_{Bmax} + 1)/(p_{Bmax} - p_{in})}$$

is called the *pressure factor* or the *utilization* of the vessel. It gives the proportion of the volume of the vessel that is effectively available for the heat transfer medium.

The working pressure should be high enough that it should not be possible for air to enter the system because of low pressure. It should be at least 0.5 bar at the highest point in the system. As the vessel is generally below the static pressure, P_{stat} this should also be added to the minimum pressure:

$$p_{in} = 0.5 \text{ bar} + p_{stat}$$

$$p_{stat} = h_{sys} \text{ (m)} \times 0.1 \text{ bar/m}$$

where h_{sys} is the system height. The calculated maximum operating pressure should be about 0.3 bar lower than the response pressure of the safety valve. The nominal pressure of the safety valve, in relation to the system admission pressure, can be taken from Table 3.5.

Table 3.5.
System admission pressure and
nominal pressure of safety valve

Preset pressure of vessel (bar)	1	1.5	3.0	6.0
Nominal pressure of safety valve (bar)	2.5	4.0	6.0	10.0

In our example a 4.0 bar safety valve is selected:

$$p_{Bmax} = p_{BmaxSV} - 0.3 \text{ bar} = 3.7 \text{ bar}$$

The expansion volume, V_D , is calculated as follows:

$$V_D = V_{col} + 0.10V_A$$

where V_{col} is the collector volume, and V_A is the system volume* = collector volume + pipeline volume + heat exchanger volume.

The factor 0.10 takes account of the maximum temperature-related volume change in the water–glycol mixture including an addition of 10% for safety.

Example:

Collectors:

Content: 5 l

Vertical distance between top edge and safety valve: 10 m

Solar circuit:

Copper tube Cu 15 × 1

Length: 25 m

Heat exchanger:

Content: 1.8

$$V_A = 5 \text{ l} + 25 \text{ m} \times 0.133 \text{ l/m} + 1.8 \text{ l} = 10.1 \text{ l}$$

$$V_D = 5 \text{ l} + 0.1 \times 10.1 \text{ l} = 6.01 \text{ l}$$

$$p_{in} = 0.5 \text{ bar} + 1 \text{ bar} = 1.5 \text{ bar}$$

$$p_{Bmax} = 3.7 \text{ bar}$$

$$V_{MEV \text{ min}} = 6.01 \text{ l} \times \frac{3.7 \text{ bar} + 1}{3.7 \text{ bar} - 1.5 \text{ bar}}$$

$$= 12.841$$

*The volume displaced by vapour in the collector connecting lines is not considered here.

From the series of standard sizes (10, 12, 18, 25, 35, 50 l) the next largest size is selected: that is, 18 l.

All the components of the solar energy system are calculated in this way.

GRAPHICAL DESIGN WITH NOMOGRAPHS

For an approximation of the dimensions of collectors and stores, nomographs are supplied by several solar system suppliers, which are tailored to company-specific products. Please contact the supplier for more information.

DIMENSIONING WITH A SIMULATION PROGRAM

There are currently several programs available for the dimensioning and simulation of solar thermal systems: see Chapter 10. In many cases, when a system needs to be assembled for a specific situation, it is advisable to use one of these programs together with reliable input data to arrive at the best design of the solar water heater. Some solar water heater manufacturers supply free dimensioning programs on their websites.

3.5.3 Dimensioning of systems for heating domestic water and heating support (central European conditions)

A solar energy system can make a contribution to room heating, especially during spring and autumn. The heating demand and technical requirements for a solar room heating system vary far more widely than those for domestic water heating. Partly for this reason, the methods and guidelines for design and performance prediction of solar space heating installations are less developed than those for water heating.

Therefore, and because space heating is mostly a requirement in temperate and northern climates, we shall limit ourselves to global dimensioning recommendations for central European climates, such as the UK, Germany and Denmark.

For these regions we can differentiate between systems with a *low solar fraction* and those with a *high solar fraction*. Of the first type are solar energy systems for which a maximum of 35% of the full heating requirement of a building is covered by solar energy. These are the main subject of this section. For systems with a high solar fraction, of significantly more than 70% of the full heating requirement, another approach is necessary in which the summer sun's energy is stored in a long-term or seasonal storage system, from which it is taken in the winter.

3.5.3.1 PRECONDITIONS

In order to be able to use a solar thermal system to sensibly support the space heating, several preconditions must be fulfilled with respect to the building and the heating system:

LOWEST POSSIBLE HEATING REQUIREMENT

Existing buildings normally have a very high heating requirement: $\sim 200 \text{ kWh/m}^2\text{a}$ or more is not infrequent. In this instance it is a fact that a generously dimensioned solar energy system can reduce the energy consumption, but cannot supply a significant contribution to the solar fraction.

In connection with the dimensioning of solar thermal systems with heating support the term *heating load* is often used. This is a performance variable, and is given in W/m^2 with respect to the living area. Just like the heating requirement, the heating load is also dependent on the insulation standard of the building and on the meteorological conditions. It is possible to determine the heating load from the annual heating requirement, the living area to be heated and the number of heating hours in the year (the so-called *full-usage hours*).

Example:

Heating requirement = $200 \text{ kWh/m}^2\text{a}$

Living area = 200 m^2

Heating hours = 1800 h/a

Heating load $200 \text{ kWh/m}^2\text{a} \times 200 \text{ m}^2/1800 \text{ h/a} = 22 \text{ kW}$

With an increasing insulation standard of the building, such as in a low-energy house (heating requirement <50 kWh/m² of living area per year), the heating requirement is about the same order of magnitude as the energy requirement for hot water heating. Here a combined system can make a significant contribution as heating support, especially in the transitional months during spring and autumn.

LOWEST POSSIBLE FEED AND RETURN TEMPERATURES

Conventional heating systems operate with feed temperatures of 50–70°C (122–158°F). The collectors can attain this high temperature level only in a very few cases during times of low solar irradiance. If, however, large surface-area heat distribution systems such as underfloor or wall surface heating are installed, the low feed and return temperatures (40°C and 25°C; 104°F and 77°F) can be generated relatively frequently by the solar energy system. In this way the solar fraction and the amount of oil or gas energy saved can quite easily amount to 20–30%.

FAVOURABLE ORIENTATION OF THE COLLECTOR SURFACES

Whereas for simply heating domestic water the alignment and pitch of a roof surface are favourable over wide ranges (see Chapter 1, section 1.1.3), an angle of incidence of at least 45° and a south-facing surface, if possible, are advantageous for solar heating support because of the low level of the sun and the shorter days during the heating months (see Figure 1.15).

If these preconditions are fulfilled, a solar heating support system can be implemented sensibly by means of an enlarged collector surface area in connection with a combination system.

3.5.3.2 APPROXIMATION FORMULAE

For an initial rough dimensioning of the system the following approximation formulae are given (central European climate):²⁴

SYSTEMS WITH LOW SOLAR FRACTION

- Collector surface area: 0.8–1.1 m² (8.6–11.8 ft²) of glazed flat-plate collector per 10 m² (107.6 ft²) of heated living area or 0.5–0.8 m² (5.4–8.6 ft²) of evacuated tube collector per 10 m² (107.6 ft²) of heated living area.
- Store volume: At least 50 l (13.2 gallons) per m² of collector surface or 100–200 l (26.2–52.8 gallons) per kW of heat load.

SYSTEMS WITH HIGH SOLAR FRACTION

- Collector surface area: 1.5–3 m² (16.2–32.3 ft²) of glazed flat-plate collector per 10 m² (107.6 ft²) of heated living area
- Store volume: 250–1000 l (66–264 gallons) per m² of collector surface.

3.5.3.3 DIMENSIONING DIAGRAM FOR SYSTEMS WITH LOW SOLAR FRACTION

Manufacturers of solar thermal systems with heating support often already offer product-specific dimensioning diagrams or nomographs. However, these are always tailor-made for the manufacturer's own components and are not generally valid.

3.5.3.4 COMPUTER-AIDED SYSTEM DIMENSIONING

Accurate dimensioning of collector surface areas and store volumes for solar energy systems with heating support is possible only with the help of simulation programs, such as T*SOL, Polysun, or TRNSYS (see Chapter 10). Passive solar gain through windows and from internal heat sources (people, devices, lighting) plays an ever-increasing role in the overall energy balance as building insulation standards increase.

3.6 Costs and yields

3.6.1 Prices and performance

The prices of solar products have decreased steadily over the past decade. For price information on systems in Europe, please refer to the *Sun In Action II* report (on www.estif.org) or the *Soltherm Europe Market Reports* (on www.soltherm.org). Also, the references at the end of Chapter 4 can give price information.

As installation costs still present an unsafe calculation value, particularly for companies new to the solar market, an estimate of the time and personnel costs for the individual installation steps is helpful.

The following example provides help for estimating installation, times and costs (on-roof installation) for a standard system for a one-family home, assuming normal conditions without any particular difficulties. Difficulties that are recognised on site that exceed the normal situation must be incorporated immediately at the calculation stage. Experience plays an important role in recognising and estimating these additional costs.

Please note that this example is for a pumped system with indoor tank, and is meant primarily to provide a checklist. The installation of a thermosyphon system delivered as one compact kit will require activities that are different from those mentioned here.

3.6.1.1 EXAMPLE CALCULATION FOR INSTALLATION

An example calculation is shown in Table 3.6.

Table 3.6.
Example calculation for fitting a solar energy system into a central European one-family home (on-roof installation, older building, central hot water heating system present, unvented store).²⁵ All prices are examples.

Description of necessary work	Work in minutes			
	Fitter	Time	Apprentice	Time
<i>Collector.</i> Fix collector surface to roof, remove necessary tiles, screw roof hooks onto rafters, replace roof tiles, transport collector to house wall, lift collector with ropes or belts, install collector in retainers, align and screw in place, position and install air tiles for feed and return lines, install pipeline connectors to collector, install bleeding equipment, insulate piping, pass pipelines through air tiles	2	360	1	180
<i>Solar store.</i> Transport store to cellar, position and install	2	240	1	120
<i>Solar circuit.</i> Install pipelines from roof to heating cellar, fit installation unit for solar circuit (safety valve, expansion vessel, circulating pump, pressure gauge, emptying and filling valve, shut-off valve, non-return valve, feed and return line thermometers), connect to store, check for leaks, flush through, piping insulation, make good any penetrations	1	480	1	480
<i>Auxiliary heating.</i> Install and connect pipes from auxiliary heating to heat exchanger of solar store to heating boiler, install circulating pump, fit non-return valve, insulate pipes	1	60	1	60
<i>Domestic water connection.</i> Fit installation unit for connection to water network (non-return valve, safety valve with connection to discharge pipe, shut-off and drain valve), install and connect cold water line to store, install and connect hot water line, install thermostatic mixing valve to limit domestic water temperature	1	120	1	120
<i>Control system.</i> Install main switch for solar energy system, fit temperature-difference controller, fit temperature sensor to collector and store and connect to controller with sensor cable, connect solar circulating pump to controller, fit temperature sensor for top-up heating and with sensor cable connect to heating controller, connect circulating pump for auxiliary heating to heating controller, connect controller to electrical network.	1	120	1	120
<i>Earthing.</i> Connect feed and return lines of solar circuit equipotential bonding strip	1	30	1	30
<i>Commissioning.</i> Fill solar circuit with solar liquid, bleed, set controller for solar circuit and top-up heating, start up system (technical description of the individual components, general sketch, electrical circuit diagram, operating instructions, maintenance plan), hand over solar energy system to owner including instructions concerning function of the system	1	60	1	60
Time in minutes		1470		1170
Fitter (€0.5/\$0.5/£0.35 per min)				
Apprentice (€0.25/\$0.25/£0.18 per min)		1470		585
Installation costs		€1051/\$1051/£736		

3.6.1.2 EXAMPLE OF A LIST OF SPECIFICATIONS

In new buildings the installation cost is reduced in comparison with retrofitting because there are fewer safety measures and no replacing of floor coverings etc., and the collector installation can take place during other roofing operations. Within the scope of a financial analysis during the installation of a new heating boiler, a domestic hot water (DHW) store 'credit' is frequently accounted for the solar energy system, as this is already included in the price, and so only the additional costs are taken into account. An example of a quotation is shown in Table 3.7.

3.6.1.3 ENERGY BALANCE AND YIELDS FOR A THERMAL SOLAR SYSTEM

The performance (or solar yield) of thermal solar systems, assuming that the dimensioning has been matched to the hot water requirements, is established by means of the losses on the way from the collector to the tap.

Figure 3.22 shows the balance of a standard solar system with glazed flat-plate collectors.

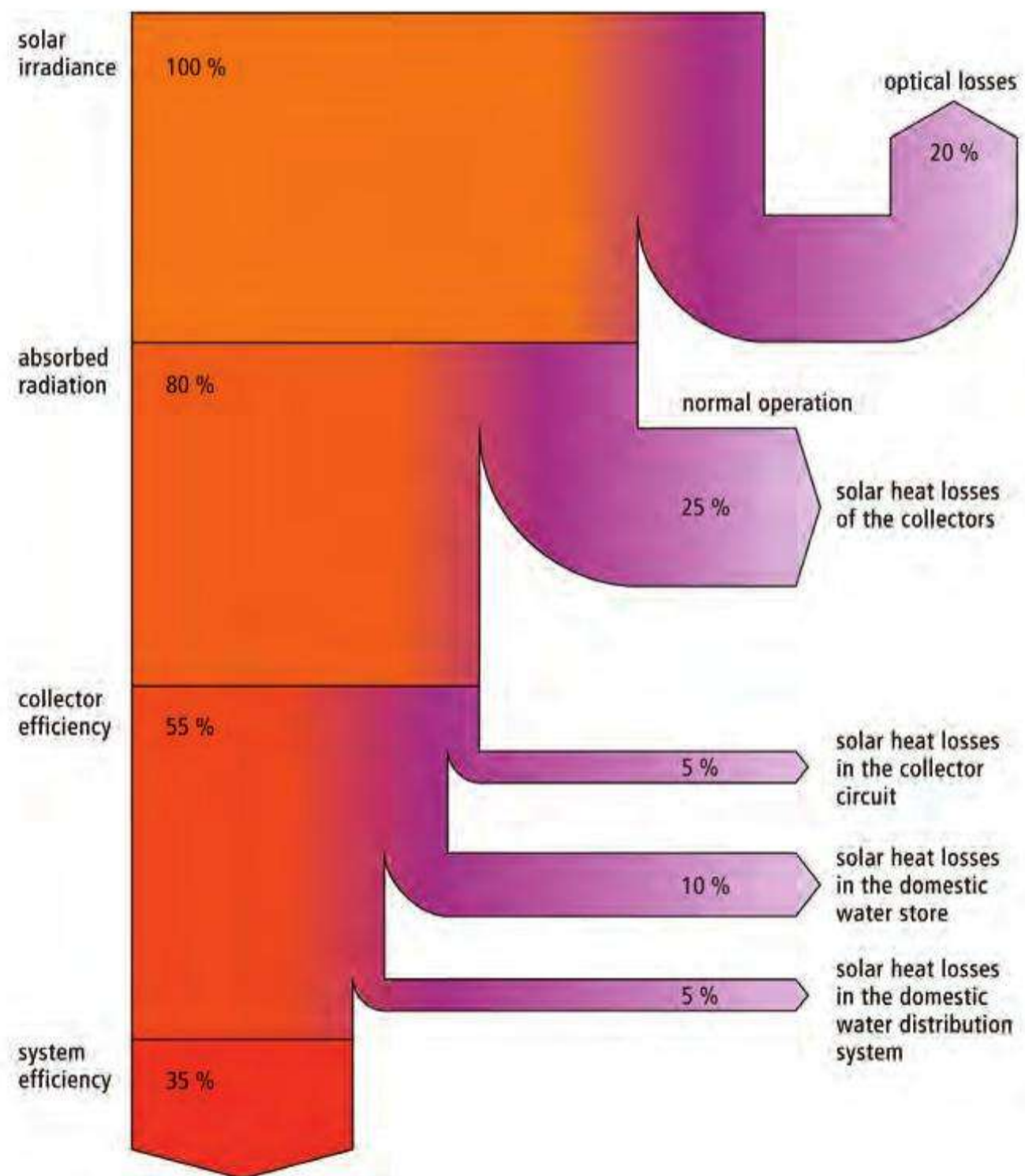

Figure 3.22.
Annual solar balance for a thermal solar system with glazed flat-plate collectors

The average system efficiency for a well-designed thermal solar system with glazed flat-plate collectors is about 35–45%. With global solar irradiance of 1000 kWh/m² per annum, each square metre of glazed flat-plate collector surface generates 350 kWh per annum of thermal energy. See Chapter 1 for determination of the global solar irradiance at different locations of the world. If evacuated tube collectors are used, the efficiency is increased to about 45–50%, because of the lower heat losses at the collector.

As already mentioned, the hot water consumption and the size of the system together determine both the system's efficiency and the solar fraction. If the hot water consumption is lower than expected, the solar fraction will be higher than designed, but the efficiency will be lower than designed. On the other hand, if there is a higher hot water consumption than was assumed, a higher solar efficiency is obtained, but the designed solar fraction is not achieved.

Table 3.7.
Quotation text as example²⁵

Item	Qty	Description	Amount
1.		Collector	
1.1	2	Collector: Manufacturer, type, surface area 1.5 m ² Collector characteristics: Give here according to manufacturer's information	€1250/\$1250/£875
1.2	2	Roof installation	
2.		Store	
2.1	1	Solar store, corrosion protection by means of sacrificial anode: Manufacturer, type, volume 300 l	€1100/\$1100/£770
2.2	1	Solar heat exchanger: e.g. plain tube, copper, e.g. 1.6 m ²	
2.3	1	Additional heat exchanger: e.g. plain tube, copper, e.g. 1.1 m ²	
2.4	1	Insulation, PU (polyurethane) flexible foam, 100 mm	
3.		Solar circuit	
3.1	2	Connection pipes to collectors: flexible stainless steel corrugated pipe with weather and UV-resistant heat insulation	€500/\$500/£350
3.2	2	Bleeding equipment	
3.3	metres	Feed and return lines, copper pipe, fittings, 22 mm, heat insulation, 300 mm, fixing materials	
3.4	1	Installation unit for solar circuit (consisting of: 4 bar safety valve, 18 l expansion vessel, 0–6 bar pressure gauge, feed and return line thermometers, emptying and filling valve, shut-off valve, non-return valve)	
3.5	1	Circulating pump: manufacturer, type, capacity	
4.		Auxiliary heating	
4.1	1	Installation unit for connecting solar store to heating boiler (shut-off valves, non-return valve)	€175/\$175/£123
4.2	1	Circulating pumps: manufacturer, type, capacity.	
4.3	metres	Piping with thermal insulation	
5.		Domestic water connection	
5.1	1	Installation unit for connecting to water mains (consisting of: non-return valve, 6 bar safety valve, with connection to drain pipe, shut-off and discharge valve)	€200/\$200/£140
5.2	metres	Cold and hot water pipelines to store (pipe materials according to existing pipe network)	
5.3	1	Thermostatically controlled mixing valve for limiting domestic water temperature to 60°C	
6.		Controller	
6.1	1	Temperature-difference controller: manufacturer, type	€250/\$250/£175
6.2	3	Temperature sensor (collector, store) and sensor cable	
7.		Excess voltage protection	
7.1	metres	Cable	€75/\$75/£53
7.2	1	Fixing set	
8.		Commissioning	
8.1	10 l	Solar liquid: propylene-glycol-based frost protection down to –25°C	€50/\$50/£35
8.2		Documentation for system (technical description, general sketch, electrical circuit diagram, operating instructions, maintenance plan)	
9.		Installation	
9.1		Specialist installation of materials given above	€1051/\$1051/£736
9.2		Travel and set-up times	
9.3		Commissioning (flushing, filling, settings, and handover of completed system)	
9.4		Training and familiarization	
Total amount			€4706/\$4706/£3294
16% VAT			€753/\$753/£527
Final sum (including 16% VAT)			€5460/\$5460/£3822

Note: this table is only to demonstrate the structure of a quotation. Amounts and VAT percentage may vary.

For quantification of these effects, computer model calculations are necessary. See Chapter 10 for an overview of solar water heating calculation models.

Table 3.8
Effect of fluctuation of hot water consumption on the yield, solar fraction and efficiency

Hot water consumption					
[Litre/Person/Day]	20	30	40	50	60
Yield [kWh/year]	1150 (-29%)	1403 (-13%)	1609	1780 (+11%)	1923 (+20%)
Solar fraction [%]	72	66	60	55	52
SN [%]	24	29	34	37	40

3.6.2 Normalized solar heat costs

The price–performance ratio of a solar system can be described with the help of the *normalised solar heat costs* (that is, the cost per kilowatt-hour). In this way the investment costs (taking account of any possible grants) and operating costs (power for the circulating pump and maintenance costs) are calculated with the energy yield during the service life.

A suitable procedure here is the *annuity method*. In this the annual charge (repayments and interest) is calculated by means of an *annuity factor*, which can then be set against the annual yield. The following example shows in a simplified procedure that the annuity is related only to the capital costs (see also Chapter 5, section 5.6). The annuity factor is given by:

$$a = \frac{(1 + p)^n p}{(1 + p)^n - 1}$$

where p is the effective interest rate (as a decimal), and n is the utilization (years).

Table 3.9.
Normalized solar heat costs for a thermal solar energy system (including VAT)

System type	Glazed flat plate 5.0 m ²	Evacuated tube 4.0 m ²
Complete price: solar system minus grant and store credit	€2250/\$2250/£1575	€3450/\$3450/£2415
Annuity factor	6.4%	6.4%
Interest and repayments	€180/\$180/£126	€226/\$226/£158
Maintenance and operating costs	€50/\$50/£35	€60/\$60/£42
Annual costs	€231/\$231/£162	€287/\$287/£201
Annual solar energy yield (kWh)	1750	1800
Normalized solar heat costs per kWh	€0.13/\$0.13/£0.09	€0.16/\$0.16/£0.11

Note: the figures in this table and the text serve as an example only and are not generally applicable.

Table 3.9 shows the results that can be obtained from the annuity method under the following boundary conditions (note: the prices are an example only and are not generally applicable):

- installation of a glazed flat-plate or evacuated tube collector system in London for 60% solar fraction of the hot water requirement
- system costs: €1000/\$1000/£700 per m² (glazed flat plate) or €1500/\$1500/£1050 per m² (evacuated tube), including VAT
- utilization: 25 years
- effective interest rate: 4%
- maintenance and operating costs per annum: 1% of investment sum
- credit for the store: €750/\$750/£525
- grant of 30% of the investment costs. N.B. In England and Wales in 2004, the subsidy level was £400 per system in private households. In Scotland it was up to 30% of system costs. Community schemes attract larger subsidies but these are subject to change.

A comparison with the costs for fossil heat generation shows that solar hot water generation can compete extremely well with electrical hot water heating, even if it still requires a subsidy.

A significant reduction of the system costs is achieved for new buildings (saving on tiled areas, lower installation costs etc.) In comparison with a retrofitted installation the costs arising are up to 20% less.

The resulting normalized solar heat costs resulting from this are reduced to: €0.10/\$0.10/£0.07 per kWh for the glazed flat-plate collector system; and €0.13/\$0.13/£0.09 per kWh for systems with evacuated tube collectors.

4 Installation, commissioning, maintenance and servicing

The installation of thermal solar energy systems involves three trade skills:

- roofing
- heat engineering (that is, plumbing and heating appliances)
- electrical.

In other words, specialist knowledge of all three areas is required if an installation is to be successful. The technical documentation of the manufacturer or the specialist literature for an individual component (particularly the installation instructions) are often insufficient.

The area in which the plumber, or the heating fitter, is often in totally new territory is usually the roofing skills. Whenever a collector assembly (field) is installed on a roof and the connecting pipes are laid into the house, work on the roof structure is also involved. It is therefore important to know and to follow the respective standards and regulations. This should help to clarify the question of which tasks the installer of solar systems can carry out, and which require a specialist roofer. For example, intervention by the heating fitter into flat roofs with plastic sheeting is definitely *not* recommended.

As it is not possible to give details of the standards and regulations for all countries in the world, this chapter gives general aspects and details of some common constructions and situations. For more information on a specific country, the reader is encouraged to make use of the references given in section 4.5.

Work tasks that the installer is likely to be familiar with already are summarised briefly, and the special solar-technical requirements are detailed. There is some reference to earlier chapters in which the individual solar components are described. Any existing guarantee obligations with respect to earlier work by skilled tradesmen must be taken into account, particularly during work on the roof or the heating system.

4.1 A brief study of roofing and materials

4.1.1 The purpose of the roof

The principal purpose of a roof is:

- to provide spatial boundaries
- to carry the loads from wind, rain and snow by means of the roof skin
- to keep the weather influences out of the building
- to enhance appearance (shape, colour, material, surface structure).

See Figure 4.1. Because of ever-decreasing fossil energy resources and the evident climate changes, the roof will in future increasingly act as the main structure for supporting energy conversion elements: that is, solar thermal or photovoltaic systems. This means that the roof skin (and the façade) will be subject to significant changes in materials and appearance.

4.1.2 Types of roof

Roofs may be classified as follows, according to the inclination:

- flat roofs: up to 5° pitch
- pitched roofs: $> 5^\circ \leq 45^\circ$ pitch
- steep roofs: $>45^\circ$ pitch.

Numerous sub-types occur, for example with two slopes.

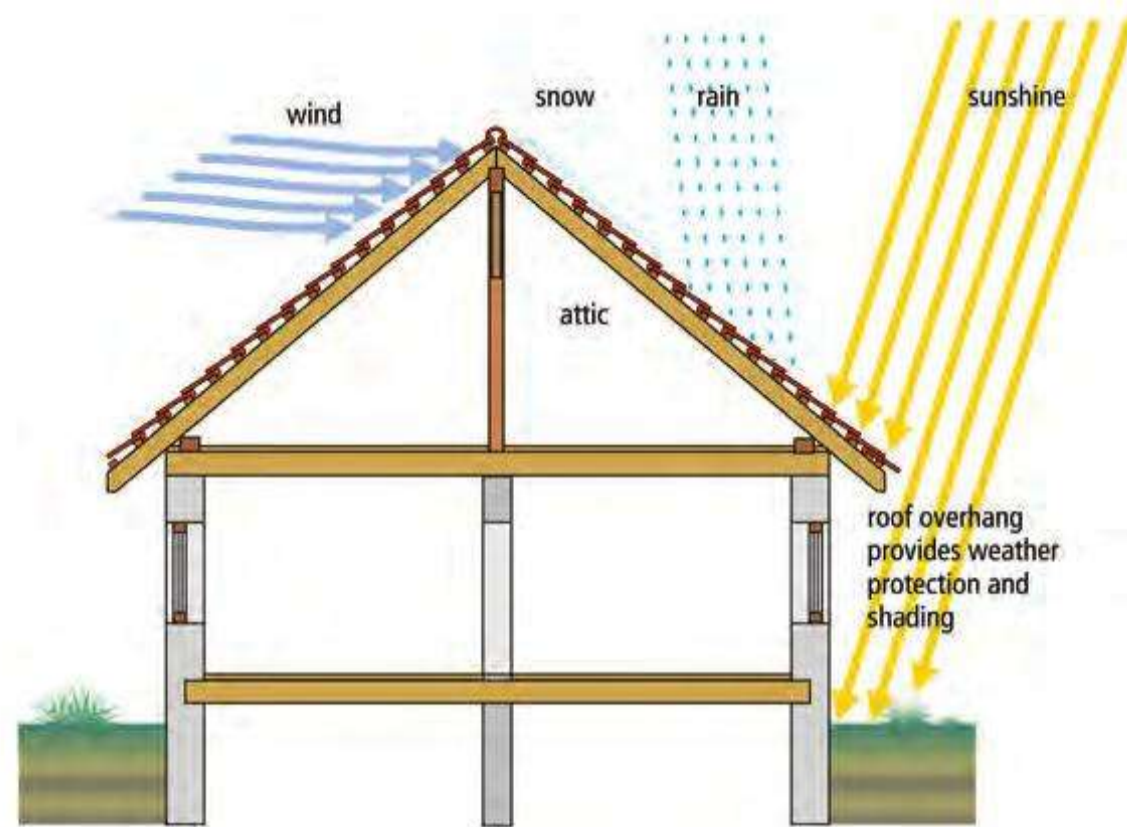

Figure 4.1.
The purpose of the roof⁶

4.1.3 The components of the roof

4.1.3.1 ROOF STRUCTURES

This section describes some roof structures that are common in Europe. The list is not intended to be exhaustive.

- *Purlin and rafter.* In the case of roof truss purlins, the rafters rest on the purlins as inclined beams. The ridge purlin takes up the vertical loads and distributes them via the posts and struts; the base purlins correspondingly distribute them to the outer walls, and there may also be intermediary purlins. An extra purlin is sometimes required to attach the collector fixings. See Figure 4.2.
- *Rafter and collar beam.* In the case of the rafter roof, the rafters and the ceiling below them form a rigid triangle. There are no internal constructional elements. In the case of collar beam roofs, each pair of rafters is linked and stiffened with a so-called collar beam. See Figure 4.3.
- *Truss.* These are self-supporting structures (glued trusses, nail plate trusses etc.) and are increasingly found in new buildings. No changes may be made to trusses without the approval of the structural engineer. For cost reasons, truss roof construction is normally found only up to spans of about 17 m (55.8 ft). See Figure 4.4.

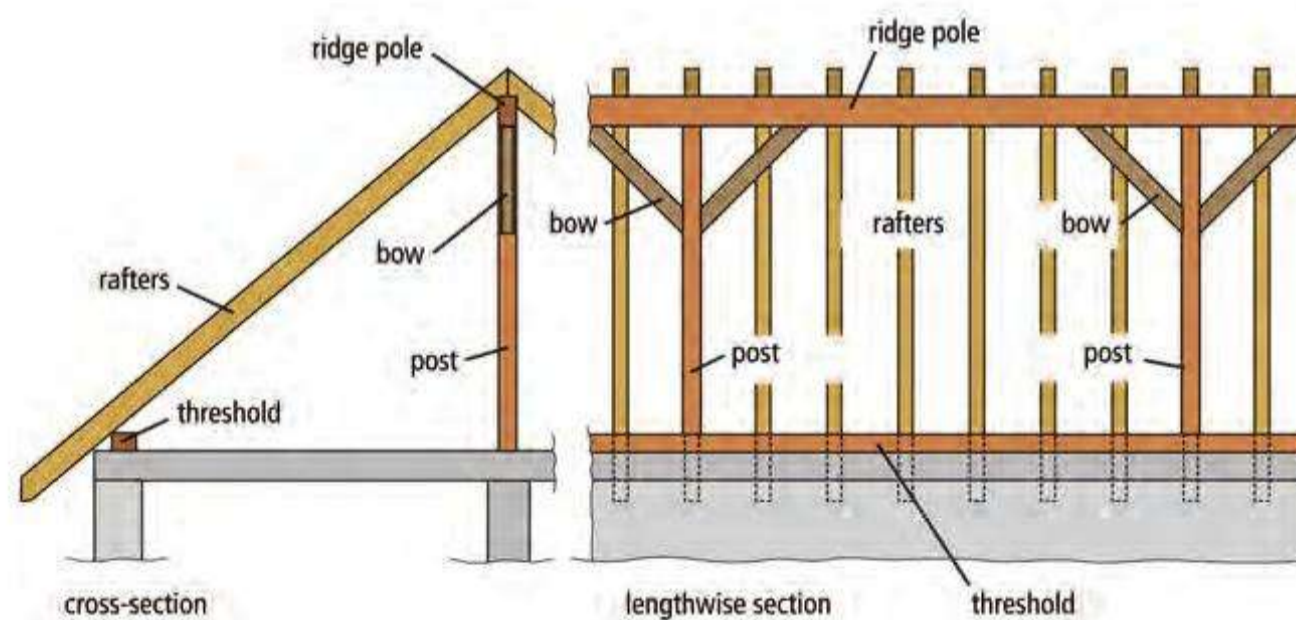

Figure 4.2.
Roof truss purlins⁶

4.1.3.2 ROOF SKIN

A differentiation is made here between roof covering and roof sealing.

- *Roof covering.* This consists of individual elements such as tiles, concrete roofing bricks, fibrous cement slabs, bitumen shingles, slates and corrugated bitumen slabs. They must have a prescribed minimum roof inclination according to the type of overlap.
- *Roof sealing* (that is, flat roofs). This consists of, for example, bitumen roof sheeting, plastic roof sheeting, or plastic material applied in liquid form and then hardened.

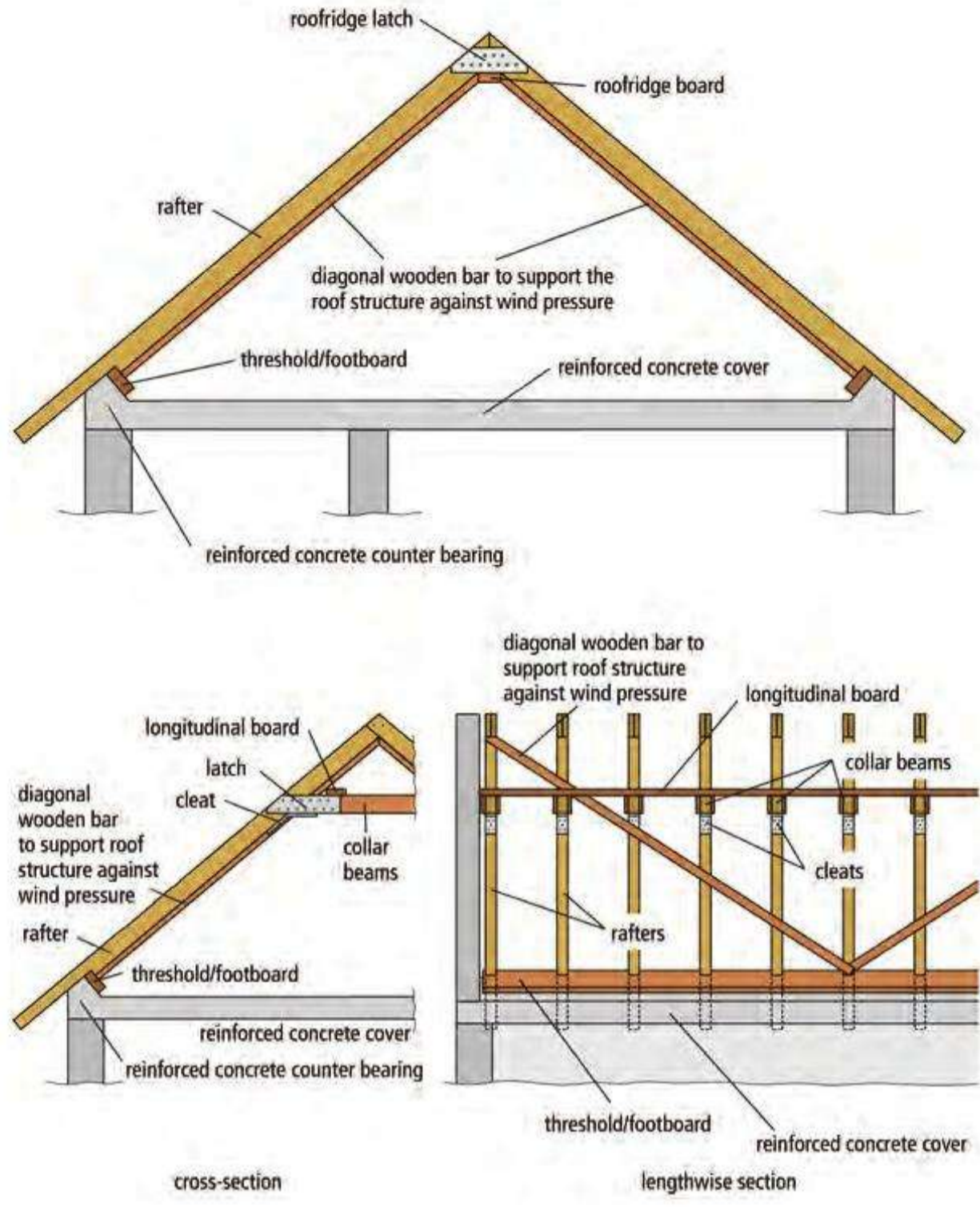

Figure 4.3. Top: rafter roof truss. Bottom: collar beam roof truss²⁶

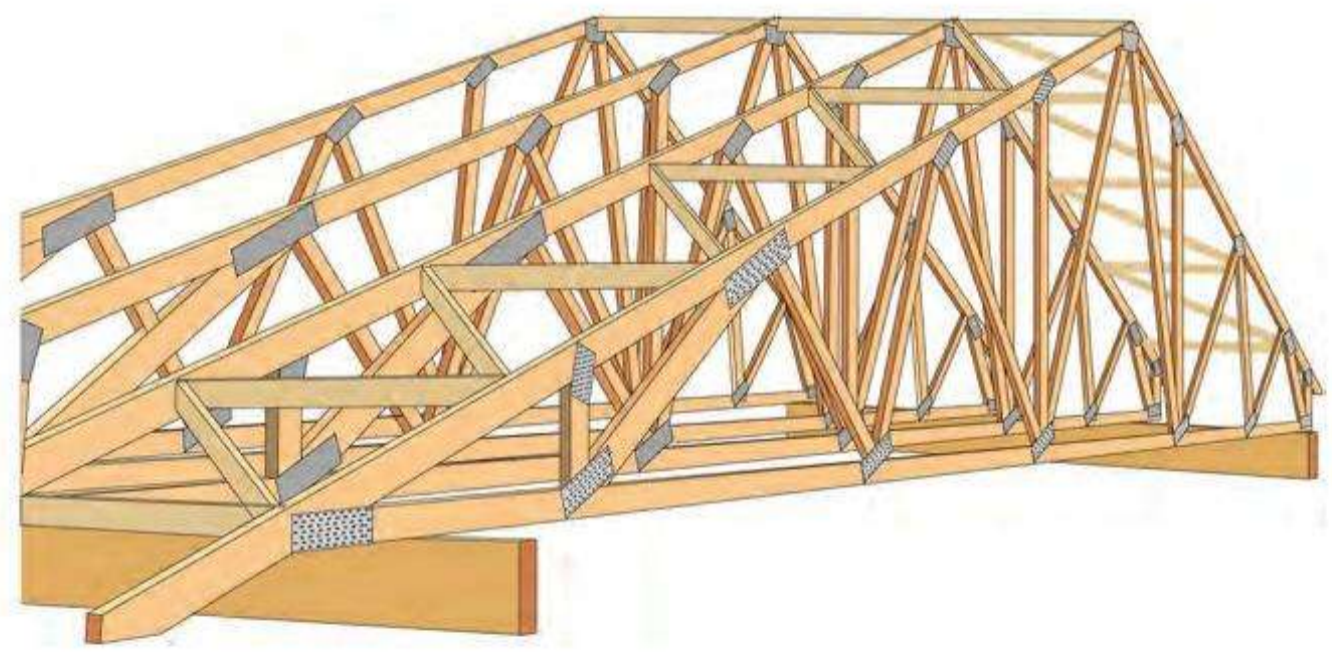

Figure 4.4. Nail plate trusses²⁶

Examples of roof coverings and seals are shown in Figures 4.5 to 4.8 and described in Table 4.1. Examples of moulded tiles, specials, roof hooks, snowguards, and walk-on gratings are shown in Figures 4.9 to 4.12.



Figure 4.5. Left: pantiles. Right: wood shingles²⁷



Figure 4.6.
Left: natural tiles. Right: plain tiles²⁷



Figure 4.7.
Left: welded sheet installation on flat roof²⁸. Right: plastic roof sheeting²⁹



Figure 4.8.
Metal roofs³⁰

Table 4.1.
Types of roof covering and sealing

Type	Examples	Material	Type of fixing, processing	Notes
Tiles	Plain tile	Clay	Dry-laid, part-clamped, sarking felt or membrane, cemented	Good back ventilation, otherwise frost damage, medium to high breaking strength, efflorescence, mould formation
	Pantiles (single Roman), double Roman, interlocking	Concrete	Dry-laid, part-clamped, sarking felt or membrane, cemented	Surface weathering, high breaking strength, efflorescence
Slates	Slate I	Natural slates, stone slabs	Nailed	Discoloration, weathering, low breaking strength RR ^a Shrinkage (when dry), swelling (when damp): drill holes must be larger, efflorescence (smears) RR ^a , draws in moisture
	Slate II	Fibrous cement ^b	Nailed	
	Circular shingling	Bitumen	Nailed, clamped	
Specials	Vents	Concrete, clay	Dry-laid	Can be offset
	Verge/eaves vents	Concrete, clay	Screwed	Impede installation of collectors
	Ridge tiles, bricks	Concrete, clay	Clamped (new build) Cemented (old build)	Impede installation of collectors
	Tiles with air pipe	Plastic, clay	Dry-laid	Impede installation of collectors
	Tiles with perforated base	Plastic, metal, clay	Screwed	Impede installation of collectors
Flat sheet metal	Box section profile roof cladding	Galvanized steel	Screwed, riveted	Zinc-plated box section plate, partially with added plastic coating, screws always in upper chord non-clamped folds, corrosion problems, good back ventilation, high thermal expansion, brittleness
	Folded covers	Zinc, titanium-zinc, copper, aluminium	Fixed with staples, folded	
	Ridge covers, chimney frame	Lead, zinc	Soldered, folded	
Profiled metal	Plastic-coated corrugation	Fibrous cement ^b	Screwed onto purlins	Not folded, water penetration through wind pressure
	Light corrugated sheets	Polyester	Screwed onto purlins	Not folded, water penetration through wind pressure
	Bitumen corrugated sheets	Bitumen	Nailed onto purlins	Not folded, water penetration through wind pressure
Liquid plastic	Roof impregnation, roof terrace sealing	Polyurethane, acrylate, resin	Cast, painted	Weather-dependent processing, carefully prepared background
Bitumen sheeting	Plastomer welded sheeting	Bitumen	Bonded, welded	Max. life 20 years, may be less than solar system, bitumen corrosion in connection with zinc plates
Plastic sheeting		EPDM	Connected with hot air	Contains plasticizer, brittleness, consider bitumen-compatibility
Organic roof	Thatched roof	Reeds, straw	Placed with wire on lathing	No known collector installation to date
	Grass roof	Film, substrate, special plants	Placed on roof	Only possible with stands

^aRR = roofer is responsible

^bAsbestos problem, special waste for these elements



Figure 4.9.
Air tiles, vapour-escape pipes and
various ridge tiles²⁷



Figure 4.10.
Left: roof hooks. Right: step³⁰



Figure 4.11.
Left: roof hooks. Right: walk-on grating³⁰



Figure 4.12.
Top: round wood holder.
Below: snowguard[®]

4.1.4 Pitched roofs

A pitched roof is often constructed as follows:

- rafters/thermal insulation
- roofing felt on formwork, otherwise sheeting beneath
- counter-lathing
- roof lathing
- tiles.

Thermal insulation can be installed in one of three ways:

- in the ceiling of the top storey
- between the rafters above head height
- over the rafters. (This is not shown in the figures: there are problems with fixing the collector, as in this case the standard parts cannot be used.)

4.1.5 Roof installations and mountings

During the installation of collectors the available roof surface can be restricted by the following features (Figure 4.13):

- room in roof
- dormer roof
- walk-in skylight
- chimneys, aerials etc.

4.1.6 Flat roofs

One can differentiate between a *cold roof* (thermal insulation under the boarding, ventilated in the intermediate space: see Figure 4.14), and a *warm roof* (thermal insulation above the boarding: see Figure 4.15). The problems of mounting collectors on warm roofs are described in section 4.3.3.2.

4.1.7 Materials

The materials used in the roof location for solar apparatus are subject to severe loads, which they must withstand over a long period, particularly if the system is expected to

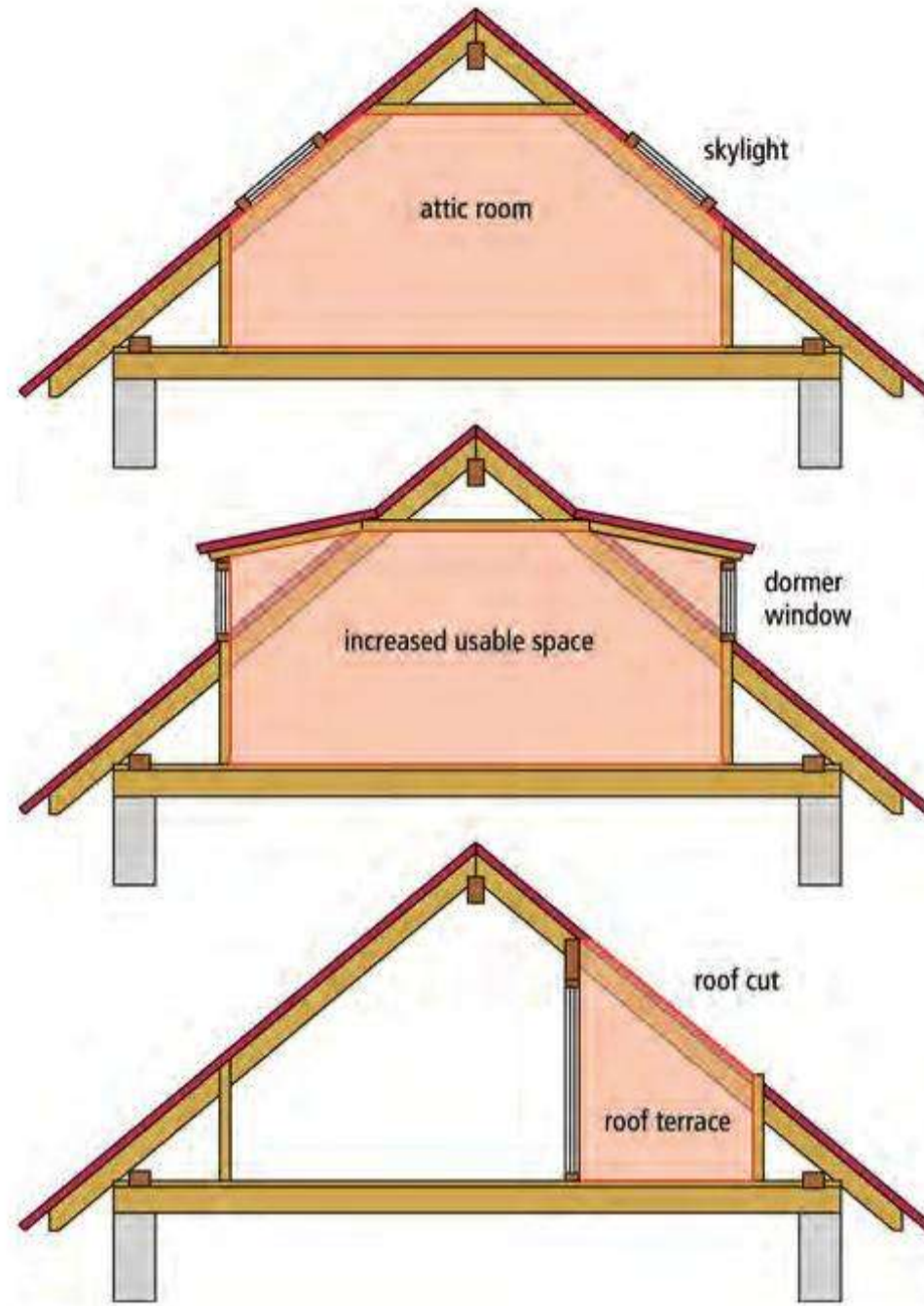

Figure 4.13. Limitations to tilted roof mounting of collectors²⁶

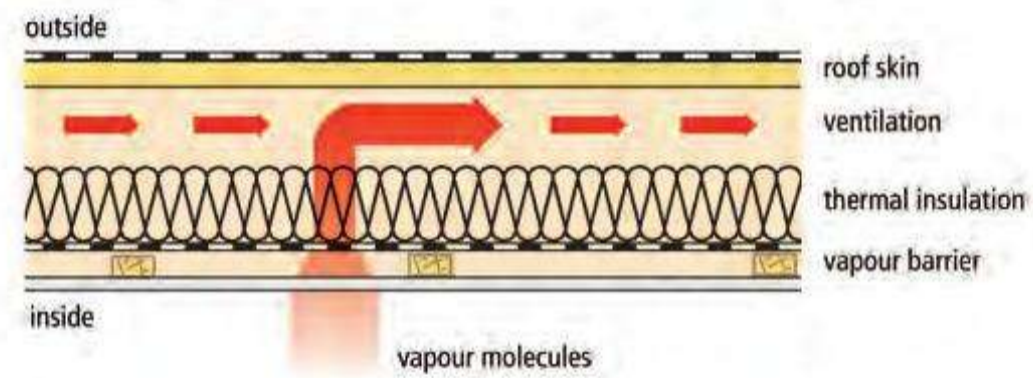

Figure 4.14. Cold roof²⁶

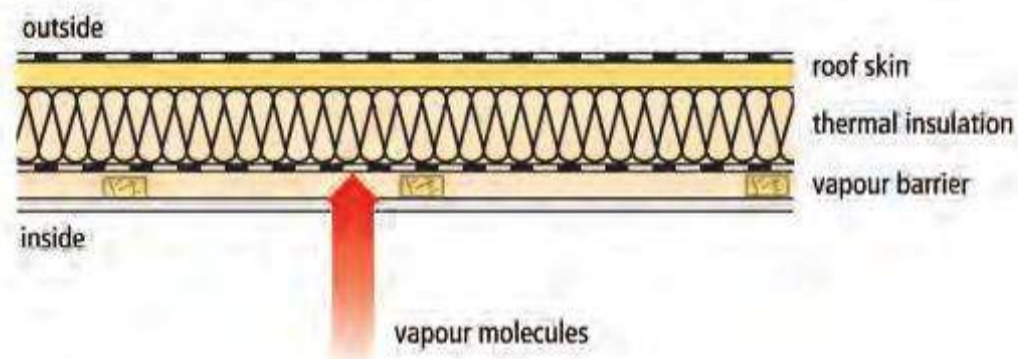

Figure 4.15. Warm roof²⁶

function and provide the predicted yields without faults for more than 20 years. The loads are:

- temperature variations between -15°C and 80°C (5 and 176°F) (and within the absorber up to approximately 300°C (572°F))
- UV radiation
- rain, snow, hail
- wind forces
- bird and squirrel damage (in the case of external thermal insulation).

Table 4.2 lists the materials that are normally used:

Table 4.2.
Materials used in roof mounting of
solar apparatus

Material	Version	Application
Aluminium	Plain, anodized, powder coated, selectively coated	Collector frames, covering frames, bearers, rails, absorbers
Glass	Float glass, solar glass (prismatic, clear), anti-reflection glass, borosilicate glass	Transparent collector cover, glass cylinder and absorber pipes
Stainless steel	V2A (St 1.4301) chrome, nickel	Roof hooks, rails, screws, nuts, plates, collector frames, absorbers
Stainless steel	V4A (St 1.4571) chrome, nickel, molybdenum, titanium	Screws, nuts, plates
Steel	Galvanized	Roof hooks, rails, screws, nuts, plates, bearers, supports
Copper	Plain, selectively coated	Pipes, absorber strips, full-surface absorbers
Titanium-zinc plate	Plain	Aprons, flashing, soakers, rear wall of collectors
Lead	Rolled, zinc plated	Lead aprons, soakers
Wood	Glued wood Solid wood	Collector frames (in-roof mounting) Additional battens (in-roof mounting), boards for under-packing
Plastics	EPDM, PE, PP, PU rigid/flexible foam, mineral wood, silicon	Thermal insulation of pipes, collector, collector frame, sealing materials, adhesive.

THERMAL EXPANSION

Materials expand during heating and contract during cooling. (The exception to this is water, which has its greatest density at 4°C; with further cooling it expands again.) It is therefore necessary to take suitable precautions in order to absorb these length changes, otherwise damage can occur. The extent of the length changes depends upon:

- the material
- the temperature difference.

$$\Delta l = l_0 \times \alpha \times \Delta \theta$$

where Δl is the change in length (mm), l_0 is the original length (m), α is the expansion coefficient (mm/mK), and $\Delta \theta$ is the temperature difference (K).

EXPANSION COEFFICIENTS (mm/mK)

- polyethylene: 0.2
- lead: 0.029
- aluminium: 0.024
- zinc: 0.02
- copper: 0.017
- stainless steel: 0.016
- steel: 0.012
- quartz glass: 0.001.

EXAMPLE

Four collectors 2.1 m high and 1.2 m wide are installed vertically beside one another. The covering plate projects by 0.25 m on each side.

$$\theta_{\text{summer}} = 70^\circ\text{C}, \theta_{\text{winter}} = -14^\circ\text{C}$$

$$\Delta l_{\text{zinc}} = 5.3 \text{ m} \times 0.02 \text{ mm/mK} \times 84 \text{ K} = 8.9 \text{ mm}$$

$$\Delta l_{\text{al}} = 5.3 \text{ m} \times 0.024 \text{ mm/mK} \times 84 \text{ K} = 10.7 \text{ mm}$$

Hence the plate expands in total by about 1 cm. It must not be impeded (for example by solders), otherwise stresses and cracks could occur, and this would result in leaks. Therefore the plates are attached to the roof lathing with retainers or, in the case of zinc, with expansion pieces. For pipes, compensators or expansion bends are used.

CORROSION

We differentiate between corrosion, corrosion signs and corrosion damage.

- *Corrosion (reaction)*. This is the reaction of a metallic material with its surroundings, which leads to a measurable change in the material, and can lead to impairment of a metallic component or of a complete system.³¹
- *Corrosion signs (result)*. These are the measurable changes in a metallic material through corrosion.³¹
- *Corrosion damage (possible consequence)*. This is impairment of the function of a metallic component or a complete system through corrosion. Corrosion can lead to damage, but does not have to.³¹

EXAMPLE

Railway tracks can rust unimpeded in the free atmosphere. However, this does not impair their function; corrosion protection is not required. In contrast, steel radiators in an open heating system will rust because oxygen is continuously drawn in. If a hole occurs in a heater because of corrosion and water runs out, the function of this component – or even of the whole system – will be affected.

CORROSION PROTECTION

If two metals with different electrochemical potentials are in metallic contact, then, in the presence of water, the more base of the two materials will decompose. Therefore different metals should not come into contact with one another in a liquid circuit if possible. If this cannot be avoided in an individual situation, electrolytic separation by means of an intermediate electrical non-conducting material is recommended. Corrosion should particularly be expected if the more base of the two metals is downstream of the more precious metal. Small particles of the more precious metal can then be precipitated on the more base material and can lead to localised corrosion (or pitting). The flow rule must therefore be: copper – in the flow direction – after steel.

EXAMPLES

Roof area

In the flow direction of the rainwater, Cu ions from the copper chimney flashing dissolve a lower-lying aluminium covering frame, which leads to pitting. In contrast, an aluminium covering frame does not have any corrosive effect on a copper gutter beneath it.

Roof frames are made from aluminium, galvanized steel or stainless steel. Galvanized material should neither be trimmed nor drilled as this would destroy the corrosion protection layer. This presupposes careful planning.

Solar absorbers made of aluminium (for example Rollbond) can become unusable in a short time if the inhibitor is not sufficiently effective, or if they are connected to a copper pipeline. The protective effect of the inhibitor should be checked occasionally.

Solar circuit

Steel pipes or fittings made of cast iron should never be mounted downstream of a copper pipeline. However, metallic connections of copper with copper–tin–zinc alloys (red bronze or brass) are unproblematic, because these alloys have a similar electrochemical potential to that of copper.³²

The corrosiveness of glycol is suppressed by suitable inhibitors. These should be checked from time to time (see Maintenance, section 4.4.5).

Storage tank

Plain ferrous materials are subject to corrosion in water, which always contains oxygen, with the formation of non-protecting rust layers. Hence corrosion protection is necessary: for example, for the domestic hot water tank an enamelling process in connection with external current or magnesium anodes or a plastic coating. Frequently, stainless high-grade steels are used.

WATER HEATING IN SWIMMING POOLS

For hygienic reasons swimming pools are treated with chlorine. This results in problems with corrosion when using copper or brass. All components which come into contact with chlorine should be made of plastics, black steel or titanium.

CAPILLARY EFFECT

According to the law of communicating pipes, liquids in pipes that are connected to one another will always be at the same level, independently of the shape of the pipes. The exception to this is that, in a narrow pipe (a *capillary*), the liquid is either at a higher level (for a wetting liquid, such as soldering tin) or a lower level (for a non-wetting liquid, such as mercury).

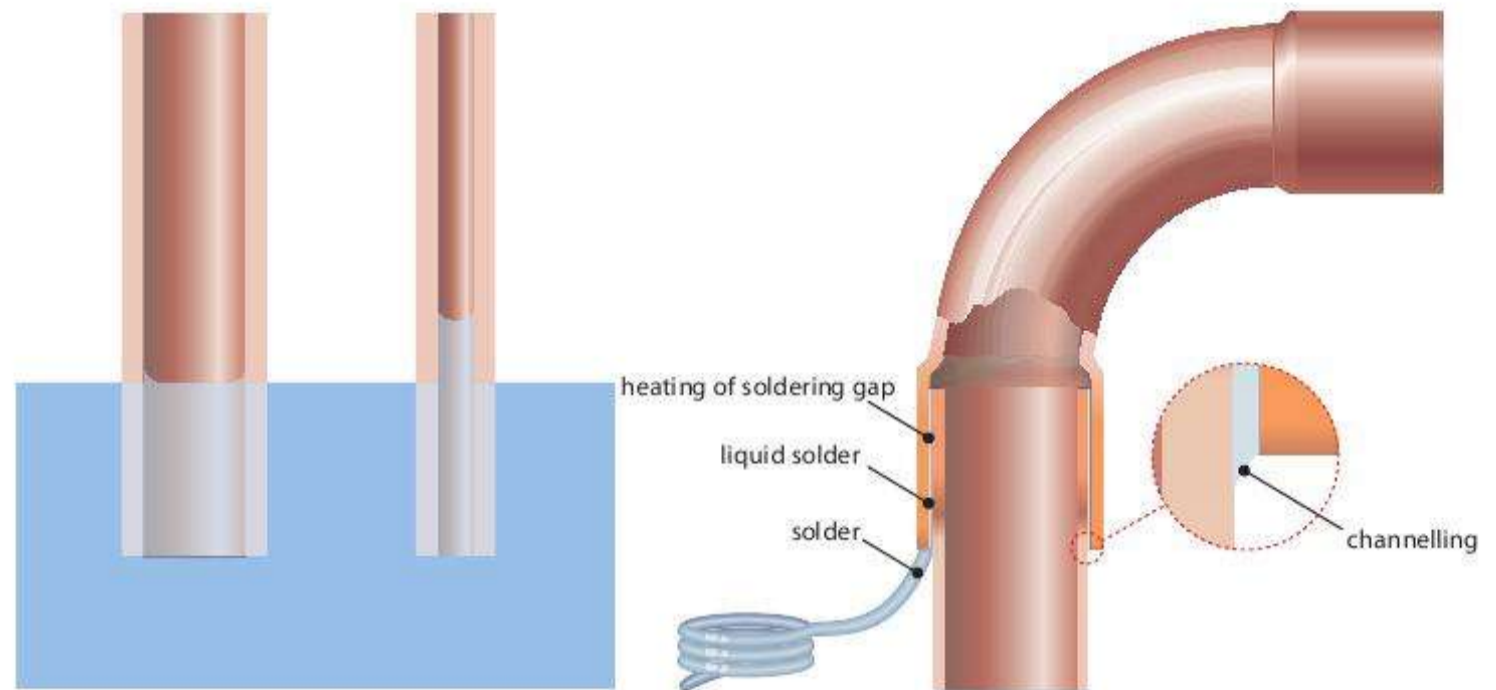

Figure 4.16.

EXAMPLE

In soldering technology, use is made of this effect in the capillary soldering fittings. The liquid tin is drawn into the narrow gap even against gravity (solder gap width from 0.02 mm to a maximum of 0.3 mm, according to the pipe diameter).

However, there can be problems due to the capillary effect on the covering frames of in-roof-mounted collectors. Here, in the presence of unsoldered side panels, which overlap in the flow direction, water can penetrate.

Table 4.3 gives an overview of the techniques.

Table 4.3
Methods of bonding roof plates

Measure	Unsuitable	Suitable
Bonding	Silicon	Butyl strip can be used with no restriction
Increasing the gap by beading the plate edges	For roof pitches < 30°	For roof pitches ≥ 30° overlapping of at least 100 mm is necessary
Soldering	For aluminium	For zinc (take account of thermal expansion)

4.2 Installation methods and safety

During the installation process, safety regulations must be followed to provide a safe situation for the workers, especially during roof work. There are large differences between individual countries regarding the safety regulations to be followed during the installation of solar water heaters. It is not possible to give up-to-date lists of all countries, and therefore regulations are given for the UK as well as general basic guidelines for central European countries to provide examples. For other countries, sources of information on safety regulations can be found in section 4.5.

4.2.1 UK safety regulations (see also Appendix B)

Advice on the requirements is found in the following Health and Safety Executive publications:

- HSG33: *Health and Safety in Roof Work*
- HSG150: *Health and Safety in Construction.*

When considering roof work of any kind, a risk assessment is mandatory. This entails:

- looking for hazards
- assessing who is at risk, and in what ways
- evaluating and taking action to eliminate or reduce the risk
- recording or communicating the findings
- reviewing the findings.

The Management of Health and Safety at Work Regulations 1999 require employers to carry out risk assessments, make arrangements to implement necessary measures, appoint competent people, and arrange for appropriate information and training.

All roof work is hazardous. Without a risk assessment roof work is also dangerous. In the UK, there is a fatal fall from height every three days.

4.2.2 UK personal access and working at heights

Solar collector roof installations typically take less than a day, and access considerations should allow for this. Nevertheless, a temporary platform at or near eaves level is an essential safety item when working at height. On a flat roof, the features of the platform are created on the roof itself, although fall prevention still needs to be added.

Working platform features are as follows:

- minimum width to cover the working area, plus a safety margin while on the roof
- sufficient strength to support loads, including personnel, tools and materials
- sufficient integrity to prevent tools and debris from falling below
- main guardrail a minimum of 910 mm (35.8 inches) above the fall edge
- toe-board a minimum of 150 mm (5.9 inches) high
- no unprotected gap between these exceeding 470 mm (18.5 inches) (that is, use an intermediate rail).

The platform width should not normally be less than that of the whole width of the roof pitch to which the solar collector is to be fixed. A small collector fixed to a very wide roof may suggest an exception to this, but consideration should be given to potential slippage across the roof from the momentum of using tools, for example. The working platform is typically supported by one of the following methods:

GENERAL STEEL SCAFFOLDING

- also known as system scaffolding or tube and fitting
- requires trained, technically knowledgeable or experienced installer to provide mandatory inspection report
- installation by trained personnel
- usually already in place during new build
- can support hoist or gin wheel for lifting collector
- can be customized to building shape
- can support external ladder
- should meet NASC (National Access and Scaffolding Confederation) guidelines
- heavy structure with long components.

MOBILE ALUMINIUM ACCESS TOWER (MAT)

- requires trained, technically knowledgeable or experienced installer and user
- inspection report not mandatory where sited for less than seven days
- modifications possible only with manufacturer's permission
- not normally capable of supporting hoist or gin wheel
- requires internal ladder access
- should meet PASMA (Prefabricated Aluminium Scaffolding Manufacturers Association) guidelines
- light structure with compact components.

4.2.2.1 LADDERS

The existing solar trade frequently uses ladders, sometimes without other access equipment; however, the only recommended use of a ladder is for personal access and short-term work (that is, within minutes). In this context the ladder should extend at least 1 m (3.3 ft) above the landing place and should be tied in to the building to prevent sideslip at top and bottom. The forthcoming EU Directive 89/655/EEC is likely to require ladder work at height only where other safer work equipment is not justified in view of the short duration of use and the low level of risk.

4.2.2.2 WORKING ON THE PITCH

A roof ladder should be used to supplement eaves edge protection on pitched roofs and to provide additional support for work. It also reduces damage to the roof coverings. The ladder should be secured against accidental movement, and the

anchorage should not rely on the ridge capping or typical gutters. The use of a ridge iron on the opposing pitch and tying onto the eaves platform support is typical. On long, steep pitches where work is near the ridge, an extra platform or safety harness may be required to reduce injury upon hitting the eaves platform in the event of a fall. All weight-loading calculations should consider a minimum of two workers plus tools and the weight of the solar collector. Furthermore, the forces invoked during drilling operations should be considered, especially where the drill and bit snatch. Working on the fragile roofs sometimes found on commercial buildings is not covered here, but suffice to say extreme caution is required.

4.2.2.3 SAFETY FENCE

A safety fence is mounted on the roof, and the side protection is firmly anchored to the rafters with ropes and special retainers. The protection fence must project beyond the working area by 2 m (6.6 ft) at each side.

4.2.2.4 PERSONAL SAFETY EQUIPMENT

This is used in addition to work platforms. Such equipment includes:

- safety harness with safety ropes and falling damper
- as above but with height safety device (the safety rope is kept taut the whole time).

4.2.3 Working equipment

The equipment required for working on the roof includes:

- roof hooks, roof-supported ladders
- roofing stool
- ladders.

These are described below.

4.2.3.1 ROOF HOOKS, ROOF-SUPPORTED LADDERS

These are light wooden ladders with cambered rungs. In Germany they are hung from the roof hooks (for safety reasons in the second rung) and placed on the roof surface. In the UK they are hooked over the ridge. They permit movement around pitched roofs with inclinations of up to a maximum of 75°. They may only carry loads of up to 1.5 kN (approximately 150 kg (331 lb)).

4.2.3.2 ROOFING STOOL

In some countries, roofing stools are used for safe working. See Figure 4.17.



Figure 4.17.
Roofing stool³³

4.2.3.3 LADDERS (ALUMINIUM, WOOD)

Standard ladders are leaned against a building. The correct erecting angle is between 65° and 75°. The ladder must extend 1 m (3.3 ft) beyond the contact point. It must be

secured against slipping, falling and sinking into the ground: that is, use wide feet, rubber mountings on feet, top suspension/fixings, or support by a safety person.

4.2.4 Transport techniques

For transporting the collectors to the roof or over the roof surface to the installation location, there are various options available according to the site conditions. Some common options are as follows.

4.2.4.1 TRANSPORT TO THE ROOF

- *Inclined surface.* This is the most frequently used method of transporting such items to the roof. To create the corresponding inclined surface, two ladders are placed beside one another at the appropriate distance apart. (Protect rainwater gutters from loads.) The collectors are then pulled up with ropes or an electric hoist attached to the scaffold, or carried up with carrying handles.
- *Inclined hoist.* Inclined hoists with electric motors can be used for transporting the collector to the roof either within the scope of roofing work (by agreement with the roofer) or they can be hired.
- *Crane.* For the transport of large-surface-area collector modules, or to reach roof areas that are difficult to access, a crane may well be essential. As crane hire is relatively expensive, accurate time planning and good preparation are necessary.
- *Lift.* Vertical lifts can be used for working on façades.

4.2.4.2 TRANSPORT ON THE ROOF (PITCHED ROOFS)

Relatively safe working on the roof is made possible with:

- roof ladder
- revealing the roof battens.

4.2.5 Installation techniques

4.2.5.1 PIPE INSTALLATION

Pipe installation techniques for solar energy systems include cutting, connecting, fixing and sealing copper and steel pipes as well as the processing of stainless steel corrugated pipe and fast-assembly pipes (twin-tube). Copper pipe is mostly used.

CUTTING

For cutting copper pipe, a pipe cutter is used. It is important to remove the internal burr after cutting.

CONNECTING

- *Soldering (capillary soldering fittings).* Copper fittings are mainly used for soldered connections. The junctions with mountings and threaded connections are made of brass or red bronze. We differentiate between two soldering processes, soft and hard soldering (brazing). Correspondingly, soft and hard solders are used. See Table 4.4.

Table 4.4.
Different types of solder

Type	Solder	Flux	Material connection	Notes
Soft solder	L-SnCu3	F-SW22	Cu-Cu	Up to 110°C permanent temperature load
	L-SnAg5	F-SW25	Cu-Cu	
Hard solder (Brazing)	L-Ag2P	No flux needed	Cu-Cu	Above 110°C
	L-CuP6	F-SH1	Cu-red bronze	

- *Press-fit (crimped).* Cold, non-releasing connections can be made with the help of compression fittings with O-rings. The advantages of this connecting technique are: no risk of fire; no environmentally damaging soldering materials; and the time saving over soldering.
- *Compression.* Cold, releasing connections can be made with the help of compression fittings with olives. The advantages of this connecting technique are: no risk of fire; no environmentally damaging soldering materials; and the time saving over soldering.

- *Screwed (clamping ring) connections.* Screwed connections can be released easily, they generate no heat during installation, and they significantly reduce the installation time, as for the compression joint. They are used mainly for the collector connections.

FIXING

In fixing the pipelines, the first thing to do is to account for temperature-related length changes (see Thermal Expansion in section 4.1.7). This is done by allowing expansion between the fixed points (clamps with rubber inserts) by installing bends or compensators. For roof openings the line must be installed to be movable (sliding guide).

SEALING

In order to seal some threaded pipes, the outside thread should be wrapped with hemp before screwing together. Teflon tape is not appropriate as, unlike hemp, it does not possess swelling properties. Therefore the high creeping capability of the solar liquid can lead to leaks in the solar circuit.

4.2.5.2 SHEET METAL WORK

The collector flashing system (zinc/aluminium sheeting) is normally prefabricated by the manufacturers. In the best case they simply need to be slotted in place.

The following sheet metal work may be necessary:

- cutting – with sheet metal shears
- connecting – folding, soldering (zinc sheet only), gluing (butyl tape), screwing (plumbers' screws)
- fixing – with adhesive, suspending
- shaping – edging (edging bench).

4.3 Installation

4.3.1 Delivery of material

Traditionally the material for the solar energy system was (and in some countries still is) delivered by the manufacturer, and the remaining installation material had to be procured from wholesalers. Increasingly, wholesalers are also selling solar systems, thereby simplifying the procurement.

When the materials are delivered the following must be done:

CHECK FOR TRANSPORT DAMAGE

Here it is particularly important to check for an intact glazing. For collectors without a metal back panel, damage can easily occur to the thermal insulation plates. There is also a risk of the covering sheets bending.

CHECK THE COMPLETENESS AND CORRECTNESS OF THE DELIVERY

To simplify and support this task, there are:

- ready-to-use packs – that is, complete kits for the installer. It is then only the installation materials (copper pipe, thermal insulation, fixing materials etc.) that still have to be replenished
- detailed advice from the supplier
- installation training courses by the manufacturer or other institutions.

4.3.2 Setting up the site, preparatory work

The final establishment of the collector position, the pipe routes through the house and the location of the store must then be agreed with the customer. The transport route for the collectors is established, sensitive components are secured (for example a glass installation beneath the transport route, or using planking to protect the mounting position on the roof from falling objects), and paths are blocked off as

necessary. The materials and tools required for installation are transported to the garage or cellar (if available) and stored there.

4.3.3 Collector installation

In principle, collectors can be:

- integrated into a pitched roof
- mounted on a sloping roof
- set up on stands on a flat roof or a free surface
- mounted in a façade.

Each of these solutions has its advantages and disadvantages. The selection of the one to be used depends on the local conditions, the type of collector, and the customer's requirements. Whereas for pitched roofs and façades the inclination and alignment are more or less preset, the flat roof or free installation (installation on the ground is very rare) allows the possibility of an exact south orientation and a favourable angle of inclination. The limitation to this is that flat-mounted evacuated tube collectors can be varied only within a certain angular range ($0\text{--}25^\circ$), otherwise the individual absorber strips will shade each other when the sun is low.

The roof work during installation should be carried out by specialists, taking account of the safety regulations. The manufacturer's instructions should be followed accurately.

The collector manufacturer generally supplies the required fixing kits. Because of the large number of different roof coverings and collector constructions, the collector installation steps will differ from one another.

4.3.3.1 INSTALLATION ON A PITCHED ROOF

Solar collectors can be mounted on the roof, or between the roofing tiles.

ON-ROOF INSTALLATION

In on-roof installation the collectors are mounted about 5–10 cm (2–3.9 inches) above the roof layer. The mounting points are often formed by roof hooks or rafter anchors, which are screwed onto the rafters, or onto a corrugated tile, a standing seam or the like. Roof hooks are formed so that they can be led between two rows of roof tiles or shingles (Figure 4.18).

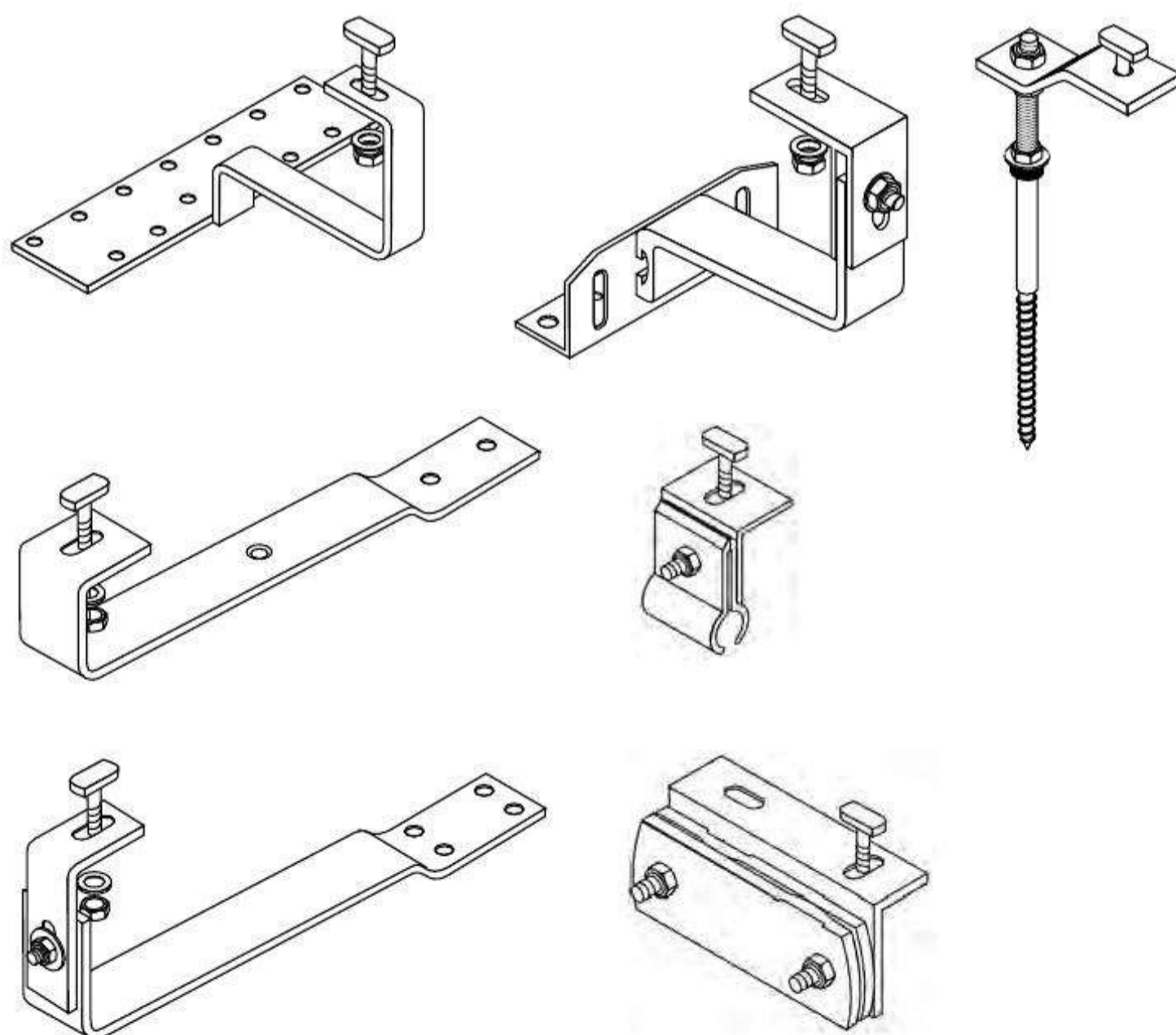

Figure 4.18.
Types of roof hook

In some countries there are roof tiles developed especially for the on-roof mounting of collectors and PV modules. These consist of plastic in various shapes and colours with the bearing element integrated, onto which the mounting rails can be directly screwed. The collectors are fixed onto these. Venting tiles are used for pipe culverts. The supporting structure of the roof (the battens) must be able to take the additional load of the weight of the collectors and the fixing system (approximately 25 kg/m^2 (5.12 lb/ft^2)). Both glazed flat-plate collectors and evacuated tube collectors can be installed as on-roof systems.

The type of roof cover (shape and colour) should be noted on a checklist during the initial site visit (see Chapter 3, section 3.5.1). The correct roof hooks (and venting tiles) can then be ordered. They are therefore available at the start of the installation, and there will thus be no building delays or interruptions.



Figure 4.19.
Special roof tiles
Source: Klöber, Ennepetal

The individual work steps for on-roof installation with interlocking tiles are as follows:

1. Set up the transport path for the collectors from the ground to the installation location: create an inclined surface with ladders, push up individual roof tiles to ensure safe movement on the roof or suspend roof ladders from roof hooks, and follow accident prevention regulations (see section 4.2).
2. Mark out the collector field on the roof.
- 3a. Install rafter anchors.
Uncover the fixing points (rafters): that is, remove the roof covering at these points.
Screw rafter anchors/roof hooks onto the rafters, and if necessary support with pieces of wood so that the roof tiles over which the roof hooks are led are not under load.
Close any holes in the roof covering.
- 3b. Alternatively, remove the roof covering at the respective points, install special roof tiles and screw firmly.



Figure 4.20.
On-roof installation
Source: Wagner and Co., Cölbe

4. Screw the mounting rails onto the roof hooks or the special roof tiles.



Figure 4.21.
Example of on-roof installation
Source: Wagner and Co., Cölbe

5. Transport the collectors to the roof, place on the mounting rails and fix with screws.



Figure 4.22.
Example of on-roof installation
with flat plate collectors
Source: Wagner and Co., Cölbe

6. Connect together with (prefabricated) thermally insulated pipes. In the case of an extended attic, mount a vent at the highest point in the external area.



Figure 4.23.
Source: Wagner and Co., Cölbe

7. Position venting tiles, connect the feed and return lines to the collector, and lead them through the roof skin into the house. For this purpose, penetrate the sheeting and the thermal insulation and close them up again properly, for example by gluing or with a sheeting element.



Figure 4.24.

8. Install sensors.
9. Connect the sensor cable to the lightning protection socket (excess voltage protection).
10. Connect to lightning conductor if required.



Figure 4.25.

This description does not replace the installation instructions from the manufacturer.

The advantages of on-roof installation are as follows:

- fast and simple installation, therefore cheaper
- roof skin remains closed
- greater flexibility (it is possible to mount closer to ridge tiles, sheet metal surrounds etc.).

The disadvantages of on-roof installation are as follows:

- additional roof load (approximately 20–25 kg/m² (4.1–5.1 lb/ft²) of collector surface for flat collectors and 15–20 kg/m² (3.1–4.1 lb/ft²) for evacuated tube collectors)
- visually not so attractive as in-roof installation
- piping partly installed above roof (weather influence, bird damage).

Practical points to consider:

- When the collector is transported to the roof there is a risk of damage to the roof gutters (metal gutters bending, plastic gutters breaking). The ladders should be set up and secured so that there are no loads on the gutters.
- Older, brittle tiles can be broken when walked on.
- On the roof, soldering bottles of only 0.5 kg (1.1 lb) should be used; these should be hooked onto the belt.
- Collectors must be suitable for on-roof installation.
- The external insulation must be UV resistant, weather resistant, high-temperature resistant and protected from bird damage. Use heat-resistant flexible foam or mineral wool in the sheet metal jacket.
- Point loads on individual tiles through the roof hooks should be avoided.

Figure 4.26 shows an example of an on-roof installation.



Figure 4.26.
Example of on-roof installation.
Source: Schüco, Bielefeld

IN-ROOF INSTALLATION

For in-roof installation, the tiles are removed at the corresponding position and the collectors are mounted directly on the roof battens. The seals at the transitions to the roof skin are achieved by means of an overlapping construction. The collectors are thereby mainly integrated into the roof cover by means of special covering frame systems of aluminium or zinc and lead (similar to skylights). Integration into a pitched roof is usually the most elegant solution from the architectural point of view. In principle only flat-plate collectors can be integrated into the roof. An example of an in-roof installation is shown in Figure 4.27.

The individual working steps for in-roof installation with interlocking tiles are as follows:

1. Set up transport route for the collectors from the ground to the installation location: arrange inclined surface with the aid of ladders; push individual tiles



Figure 4.27.
Example of in-roof installation.
Source: Schüco, Bielefeld

upwards to create safe walkways on the roof, or suspend roof ladders from the ridge. Observe the accident prevention regulations (see section 4.2).

2. Mark out the collector field on the roof.
3. Uncover the field (somewhat larger than the collector surface area) and remove the greater part of the tiles.
4. Mount the fixing brackets and stop rails on the rafters.
5. Transport the collectors to the roof, place them on the roof lathing, slide them into the fixings, align laterally and screw into place.
6. If there are several collectors, insert plug connectors with O-ring seals or mount heat-insulated pipe connectors.
7. Connect the feed and return pipes to the collector and lead them into the house through the roof skin. To do this, penetrate the membrane and the thermal insulation and seal properly again, for example using adhesive or by means of extra felt/membrane.
8. Mounting the sensors: insert glazed flat-plate sensors into sensor sleeves. For vacuum tube sensors open the main line, screw sensor to feed (under thermal insulation as close as possible to exit from glass tubes), close main line again.
9. Cover up lower edges, fix lead aprons (usually suspended from within the collector frame).
10. Mount side roofing plates and then the top ones; the side plates must project over the lead aprons.
11. If necessary, insert metal or sealing strips between the collectors.
12. Cover the roof tiles at the sides. If necessary use half roof tiles; if absolutely necessary cut roof tiles and then cover them from above, ensuring sufficient overlap (at least 8 cm (3.2 inches)).
13. Shape lead aprons around the roof tiles.
14. Store left-over tiles as reserves or dispose of them.

This description does not replace the installation instructions by the manufacturer

The advantages of in-roof installation are as follows:

- No additional roof loads are applied.
- It is visually more appealing (roof covering frames can be obtained in different colours from some manufacturers).
- Pipes are laid beneath the roof cover.
- Saving of roof tiles (new build), reserve tiles (old build).

The disadvantages of in-roof installation are as follows:

- More expensive materials and mounting work.
- The roof skin is 'broken through', creating possible weak points.
- There is a possible need to transport excess tiles away (costs).
- It is less flexible: because of the covering frames there must be greater distance from ridge tiles, window and chimney surrounds.

4.3.3.2 MOUNTING ON A FLAT ROOF

In principle, collectors on flat roofs should be set up at an appropriate angle (see Chapter 1). For this purpose, flat roof stands are available made of galvanized steel or aluminium with the corresponding setting angles. (The exception to this is direct flow-through evacuated tube collectors: see below.) Because of the surfaces that are exposed to the wind, these collectors must be secured from lifting up and falling, or from sliding.

There are three options:

- *Counterweights* (concrete thresholds, gravel troughs, box section sheet with gravel filling). Approximately 100–250 kg per m² (20.5–51.2 lb/ft²) of collector surface for flat collectors and about 70–180 kg/m² (14.3–36.8 lb/ft²) for heat-pipe collectors (maximum 8 m (26.3 ft) mounting height above ground level according to building height); beyond this larger loads are necessary.
- *Securing with thin guy ropes*. The precondition for this is the availability of suitable fixing points.



Figure 4.28.
Counterweights concrete tie/sleeper or
trapezoidal sheet metal with gravel filling
Source: Wagner and Co., Cölbe

- **Anchoring to the flat roof.** Here a suitable number of supports are screwed to the roof and sealed. Bearers are fitted to these supports, on which the flat roof stands that carry the collectors are mounted.

(See Figures 4.31 and 4.32 for examples.) In every case the bearing strength of the roof must be checked first.

The working steps for flat roof mounting in detail (for example flat collectors on box section sheet with gravel filling) are as follows:

1. Set up transport route for collectors from the ground to the installation location: create sloping surface with ladders, follow accident prevention regulations (see section 4.2).
2. Mark out collector field on roof.
3. Lay out the building protection mats and the box section sheet.



Figure 4.29a, b.
Flat roof mounting
Source: Wagner and Co., Cölbe

4. Set up the flat roof stands, connect to box section sheets.
5. Transport collectors to roof.
6. Install collectors on the flat roof stands.

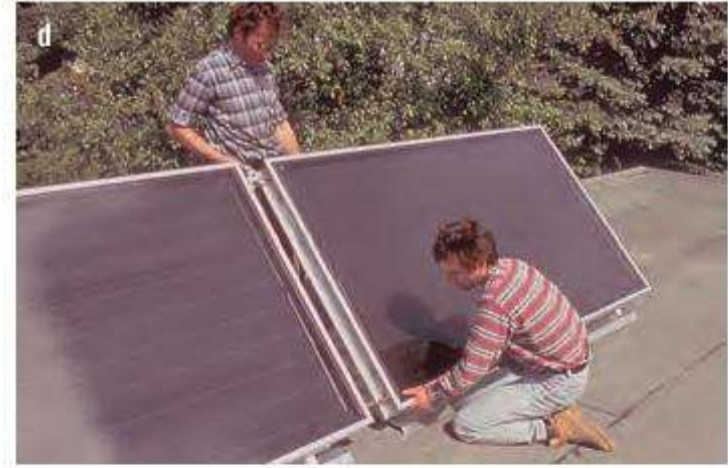

Figure 4.29c, d.
Flat roof mounting
Source: Wagner and Co., Cölbe

7. Make piping connections between collectors, mount vent at highest point.

Figure 4.29e, f.
Flat roof mounting
Source: Wagner and Co., Cölbe



8. Connect the feed and return pipes
9. Mount the collector sensor.
10. Install the gravel filling on the trapezoidal sheet (10–15 cm; 3.9–5.9 inches) in order to increase the weight.

Figure 4.29g, h.
Flat roof mounting
Source: Wagner and Co., Cölbe

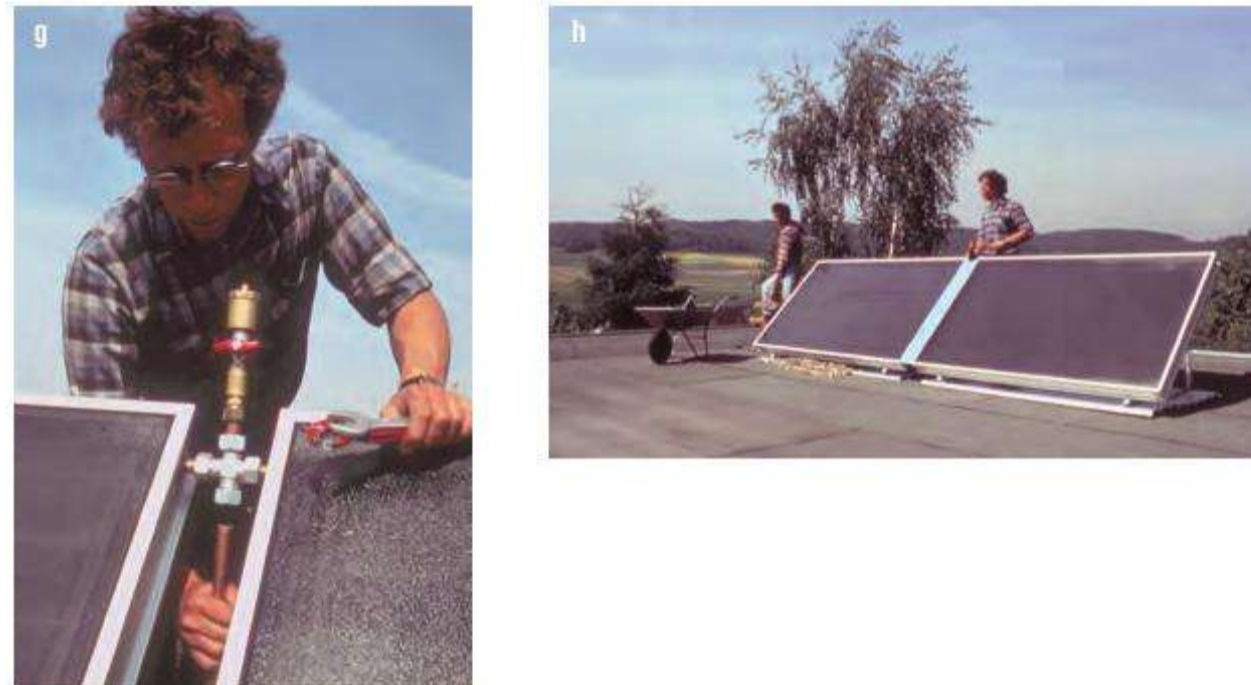

This description does not replace the installation instructions by the manufacturer.

Direct flow-through evacuated tube collectors can be mounted flat; see Figure 4.30.



Figure 4.30.
Direct flow-through evacuated tube
collector on a flat roof.
Source: Viessmann, Allendorf

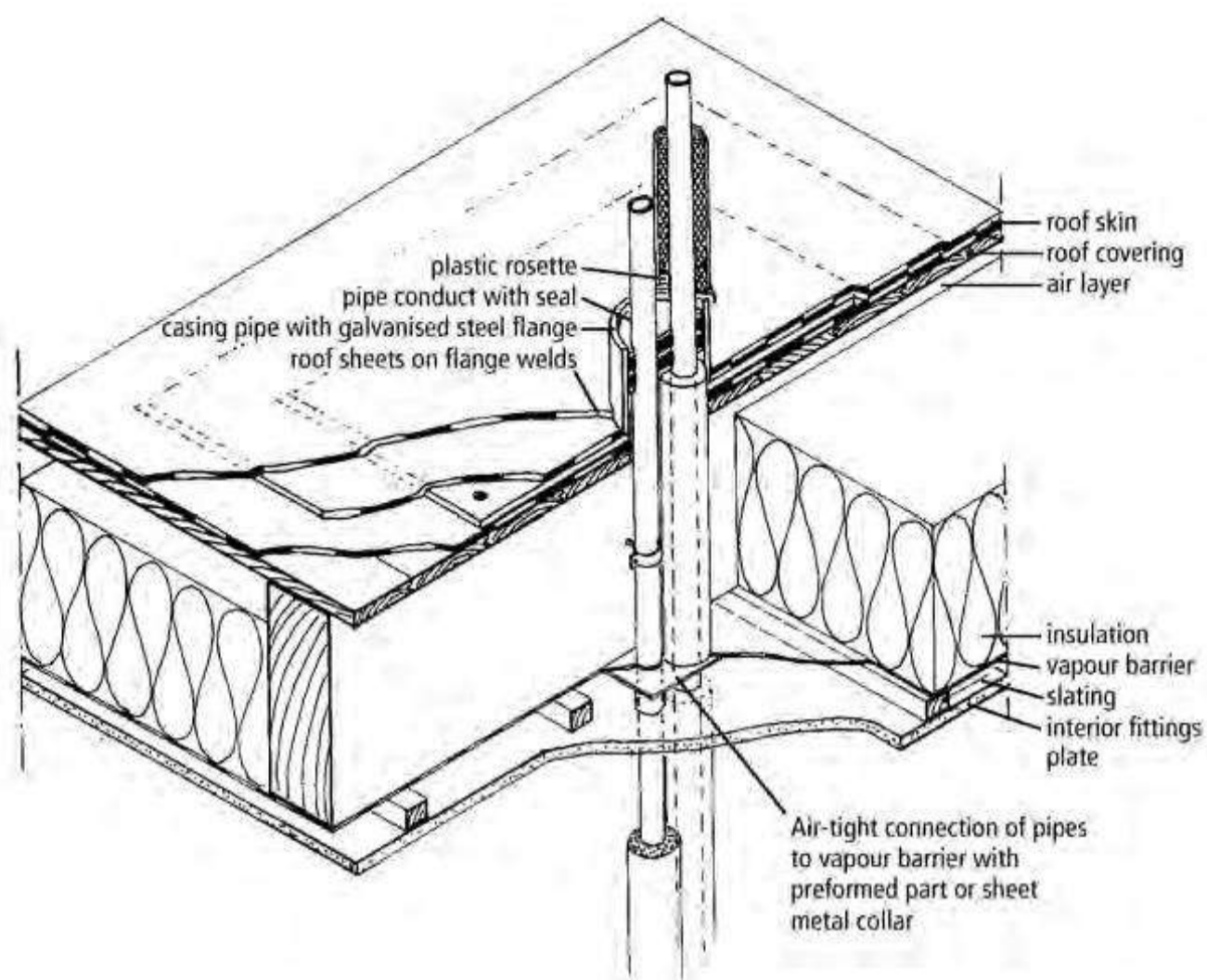

Figure 4.31.
Roof opening.
Source: Sol.id.ar, Berlin



Figure 4.32.
Government Press Office, Berlin.
Source: Viessmann, Allendorf

The individual installation steps are:

1. Establish collector positions.
2. Lay out the building protection mats and cast concrete blocks (paving slabs).
3. Assemble collector and distributor boxes.
4. Assemble bottom rails.
5. Install evacuated tubes.

For the horizontal installation of vacuum tube collectors there are two options for aligning the collectors:

- tubes longitudinal facing the equator, absorber horizontal
- tubes transverse facing the equator, absorbers adjusted by about 20–30°.

Anchoring or fixing with guy ropes is not necessary; only counterweights are required on building protection mats (approx 40 kg/m² (8.2 lb/ft²) depending on height).

The advantages are:

- fast and simple installation (low installation costs)
- no stand costs
- no penetration of roof skin at the fixing points

- low roof loading because of lighter counterweights, as there are lower wind loads
- in the case of listed buildings the collector field can be installed so that it cannot be seen.

The disadvantages are:

- higher costs for evacuated tube collectors
- lower yield when the sun is at low level.

The collectors are connected together hydraulically according to the circuit diagram. The fixing of the pipes and the collectors can take place on cast concrete blocks. The header pipes must be led into the building. There are two options to do so: the first is pipe installation in an unused chimney flue. The advantages of this are:

- no sealing problems on the roof
- no roof breakthroughs necessary
- pipe installation possible right into the cellar, and frequently directly into the heating room.

Preconditions are:

- free chimney flue
- the chimney must not be offset
- information has to be provided to the chimney sweep.

The second option is pipe installation through a roof opening. Practical points to consider in flat roof installation are as follows:

- Special care is required when working on flat roofs, as the roof skin can be easily damaged, and this can lead to leaks and consequential damage. For example, sharp-edged objects can easily break through (roofing felt pins, bent remnants of zinc plate, etc.). In the summer, bitumen becomes soft and deep indentations can arise from collector corners and edges.
- If the supporting structure is made on site it is necessary to ensure matching accuracy and good corrosion protection. Galvanized materials should not be processed afterwards – that is, drilled or cut to length – as the zinc plating that would have to be applied afterwards to the ungalvanized places is not as durable as hot-dip galvanizing.
- An advantage in flat roof installation is that the collectors can usually be set up with the optimum orientation and inclination.
- In areas that have a lot of snow, a gap must be left between the roof surface and the bottom of the collector, which is set according to the winter snow level.
- For flat roof installation the maximum load and the distance to the edge of the roof must be set with care.

INSTALLATION ON WARM ROOFS (THERMAL INSULATION ABOVE THE BOARDING)

For warm roofs the fitting of the heavy counterweights for flat collectors is not possible. For this reason a roof anchoring system is necessary.

- *Old buildings.* Cut out roof skin and insulation material, screw stand feet to the concrete roof/ceiling joists, replace insulation material, close roof skin, bond in stub pipe to provide a good seal.
- *New buildings.* In this case the stub pipe is fitted first; then the thermal insulation and the roof skin are fitted, and the stub pipe is bonded in to provide a good seal.

In both cases cold bridges are created, with the risk of condensation formation. It is therefore better to use stub pipes with thermal separation.³⁴

In the case of direct flow-through evacuated tube collectors, lower counterweights are required. If these are distributed over a large surface area they can also be installed above the roof skin on warm roofs, for example sheet metal with gravel filling.

MUTUAL SHADING

If the collectors are set out in several rows behind one another, the distance between the rows must be great enough so that no or as little shade as possible occurs.

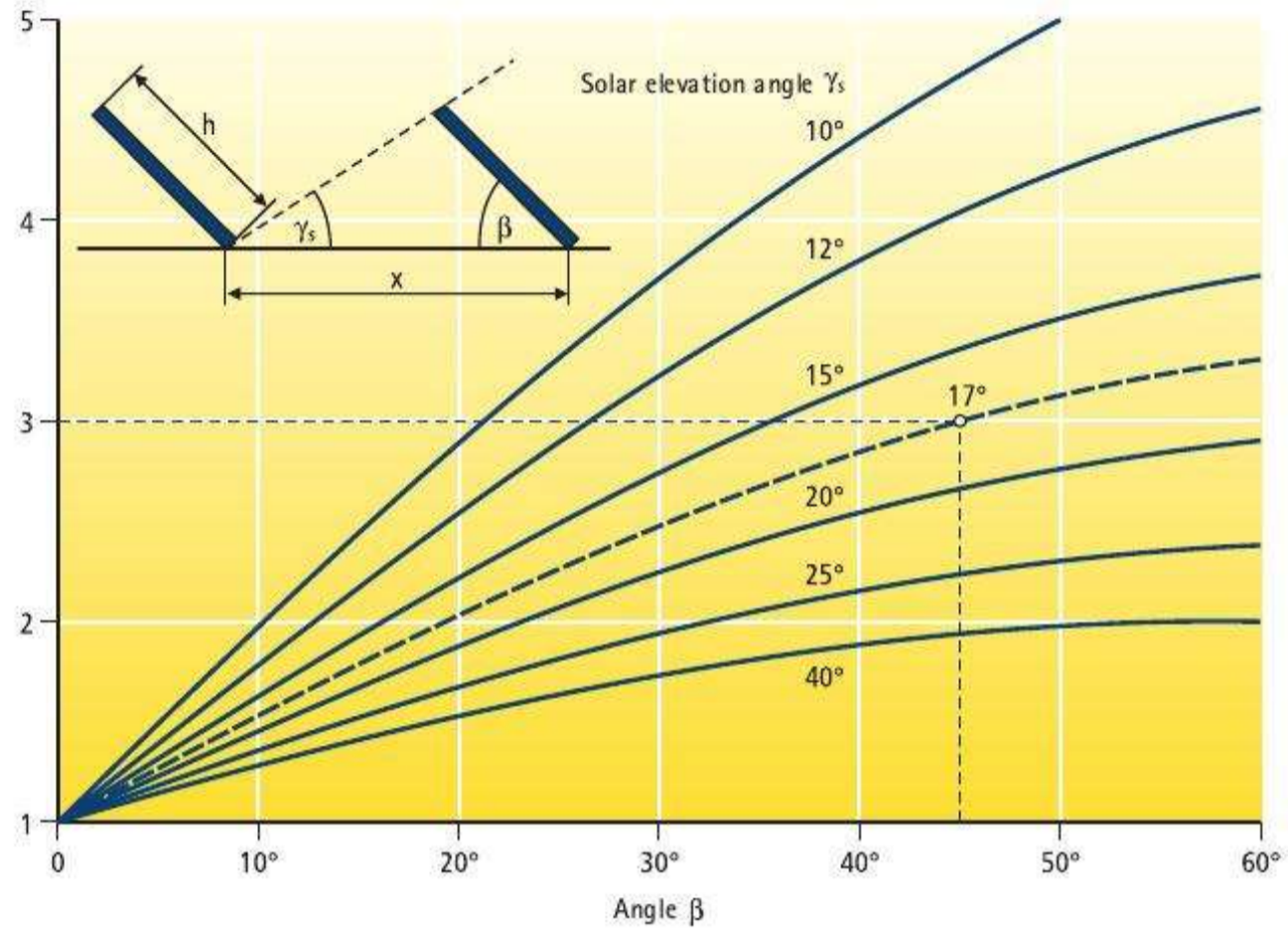

Figure 4.33. Distance between the collector series in a flat roof assembly for Germany

If the collectors are too close to each other, the amount of indirect radiation is reduced, and there may be direct shading. For direct shading, see Chapter 1. To estimate the reduction of irradiation caused by shielding of indirect radiation, the following formula, which is valid for most types of climate, may be used:

$$\Delta I = \beta \times \frac{f_{dif}}{180 - \alpha}$$

and

$$Y = \frac{1}{\tan(\beta)}$$

where ΔI is the reduction in irradiation (dimensionless), β is the shielding angle (see Figure 4.34) (degrees), f_{dif} is the fraction of diffuse radiation for a specific location (for instance, in central Europe this is about 0.6, in southern Europe it is about 0.2), and α is the tilt angle of the solar collectors (degrees).

For instance, assuming a project in central Europe (60% diffuse radiation), with a collector tilt angle, α , of 36°, in order to limit the reduction of irradiation, ΔI , by mutual shading to 10%, we would obtain a maximum shielding angle, β , of 24°.

This corresponds to a distance, Y , from the bottom of one collector row to the top of the next row that must be at least $1/\tan(24^\circ) = 2.2$ times the collector height, h (see Figure 4.34). Thus, if the height, h , is 1 m (3.3 ft), Y should be at least 2.2 m (7.2 ft).

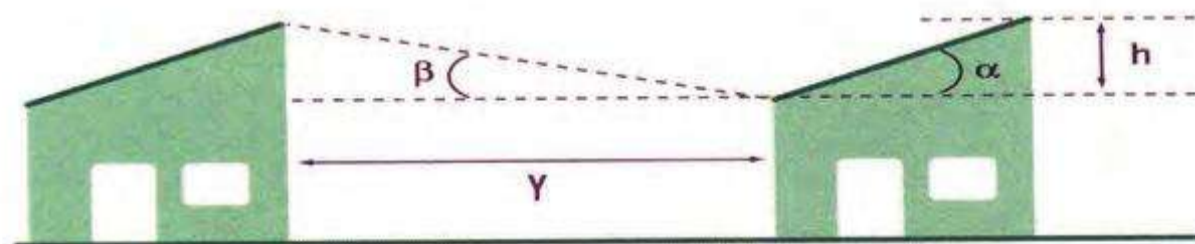

Figure 4.34. Recommended distance between collector rows for flat roof installation

4.3.3.3 INSTALLATION ON THE FAÇADE

In principle, flat collectors and evacuated tube collectors can also be mounted on façades, especially at higher latitudes, where the tilt angles are higher. See Figures 4.35 and 4.36. Façade installation, however, currently plays only a minor role. However, with the background of a possibly higher solar fraction in the winter and in particular as an architectural design element (for example coloured absorbers) it is becoming increasingly popular in some countries.

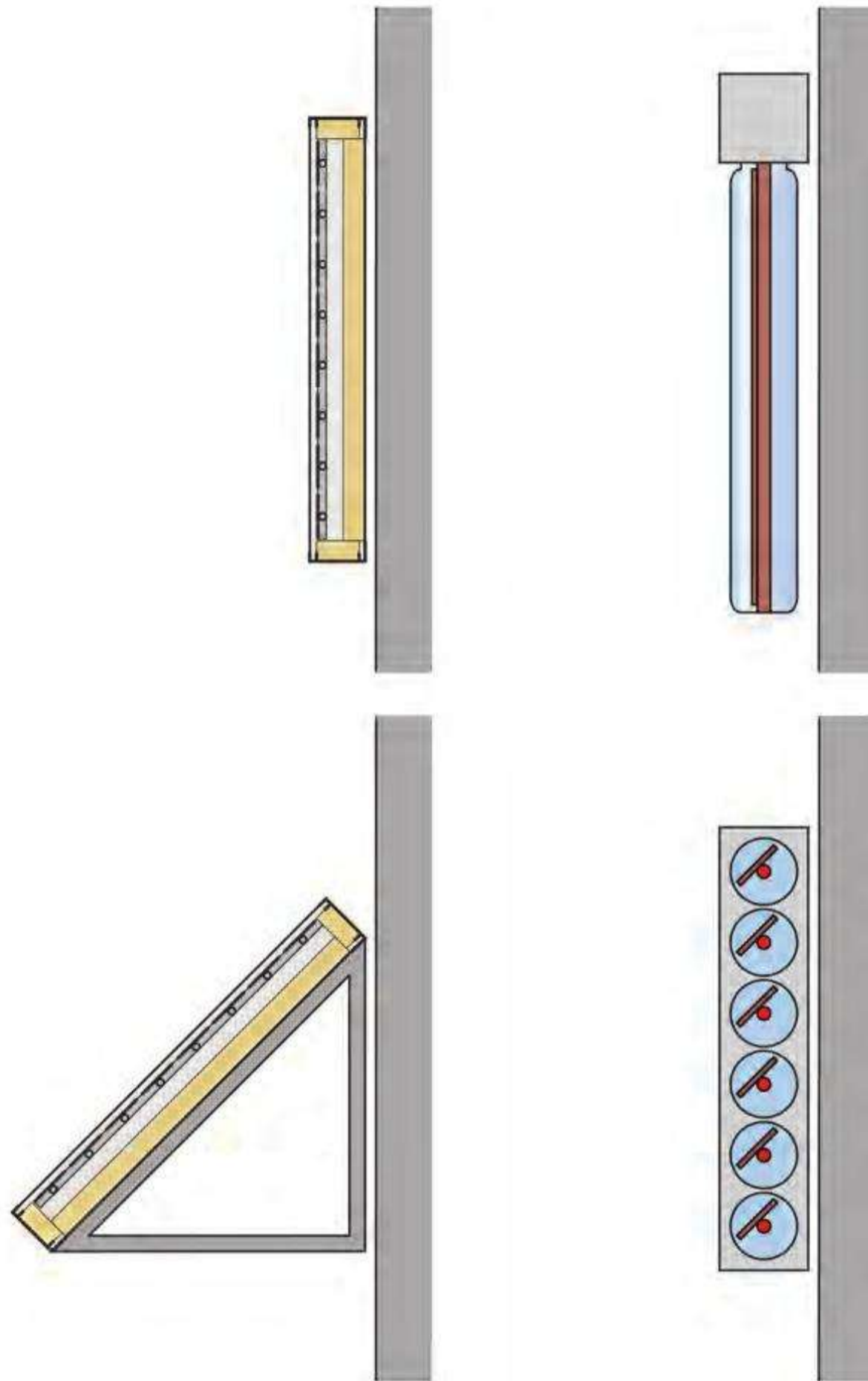

Figure 4.35.
Façade installation. Left: flat plate
arranged vertically/inclined. Right:
evacuated tube vertical (vertical pipes);
horizontal (absorber set at 45°)



Figure 4.36.
Façade installation of a large surface
collector in Bielefeld. Source: Wagner &
Co, Cölbe

The glazed flat-plate collectors used should be mounted in the same way as on the flat roof. They are frequently screwed to the wall with the same stands that are used on the flat roof.

Evacuated tube collectors are attached to the wall with their collectors and their base rails, sometimes as transverse tubes with the absorber and sometimes with vertical tubes.

For façade installation the following points should be observed:

- the bearing strength of the wall
- shading
- pipe installation
- wall ducts
- appearance.

A collector that is installed on the façade receives a lower annual global solar irradiance than a roof installation. However, it has a more uniform yield profile per year, and is subject to lower thermal loads: that is, there are fewer stagnation periods. As can be seen in Figure 4.37, a façade system with a collector surface area of more than 12 m² (129.2 ft²) achieves the same yield as a comparable roof system with lower material stresses. In addition, positive effects can be achieved in the architectural façade configuration.

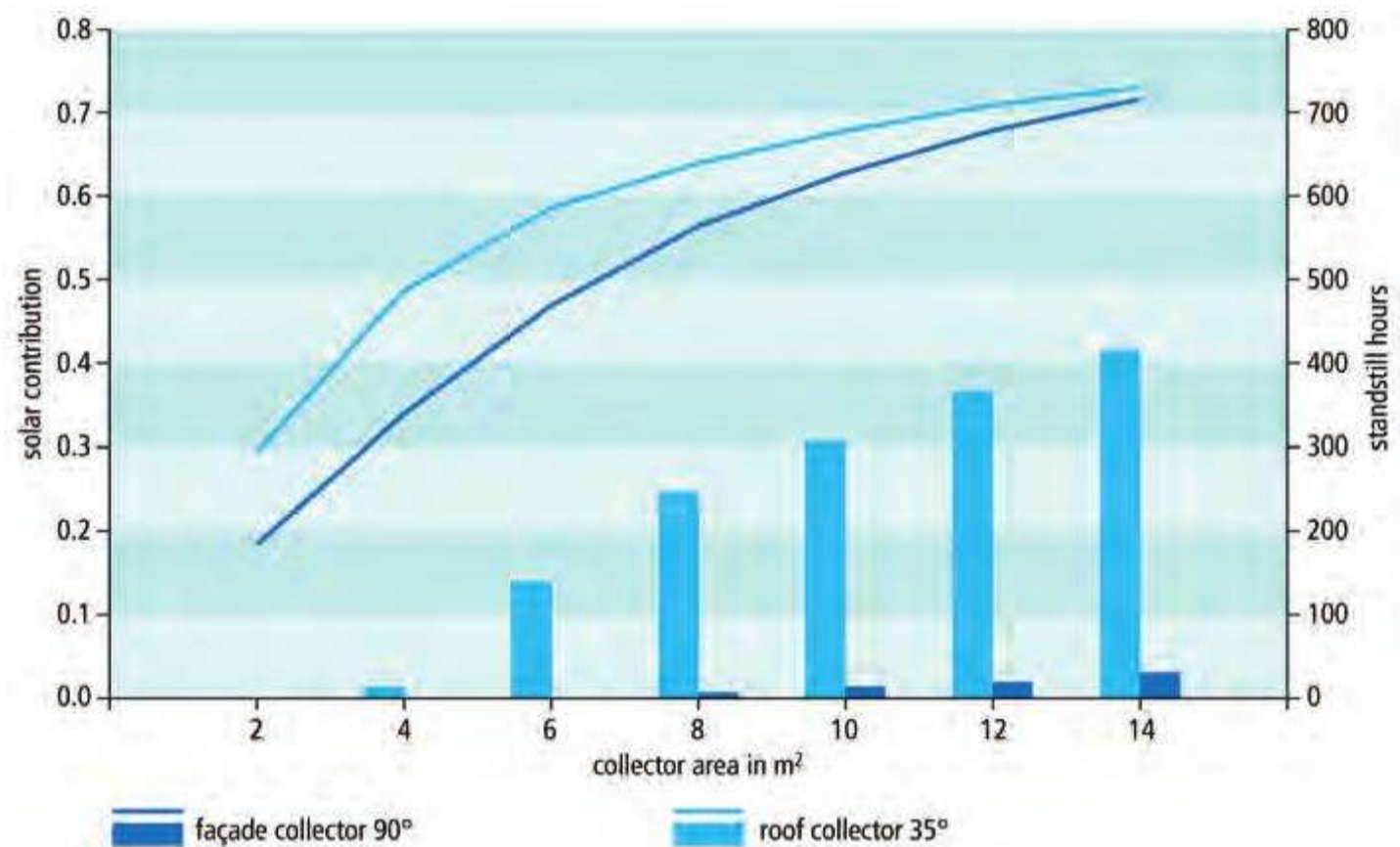

Figure 4.37. Comparison of façade and roof-mounted systems for domestic water heating and heating support, location Würzburg⁹⁵

4.3.3.4 CONSTRUCTION OF THE COLLECTOR FIELD

If several collectors are connected together as a complete surface the question of the connecting arrangement arises. The objective is to achieve a uniform flow rate throughout the whole field. Non-uniform flow rates cause different temperatures in the collector field, with negative effects on the control behaviour and the collector yields. In principle we can differentiate between parallel and series connection. The two connecting arrangements can also be combined.

PARALLEL CONNECTION

In this case all the collectors are installed between two header pipes – one distributing and one collecting header pipe. To achieve uniform flow rates the header pipes should have a lower flow resistance (that is, a larger tube cross-section) than the collectors. All flow paths should have the same length, this is called Z-connection or Tichelmann connection.

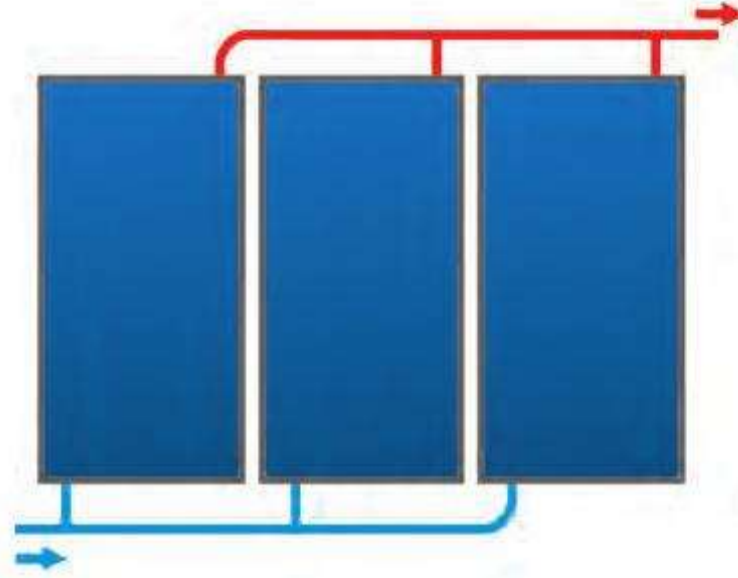

Figure 4.38.
Parallel connection

SERIES OR ROW CONNECTION

As the name indicates, with this type the collectors are connected successively. The flow rate that is necessary in order to deliver the heat arising increases in proportion to the number of collectors, but the flow resistance increases exponentially. Because of the significantly increased pumping power required, the number of rows in connected collectors is limited. This circuit arrangement ensures uniform flow through the collectors.

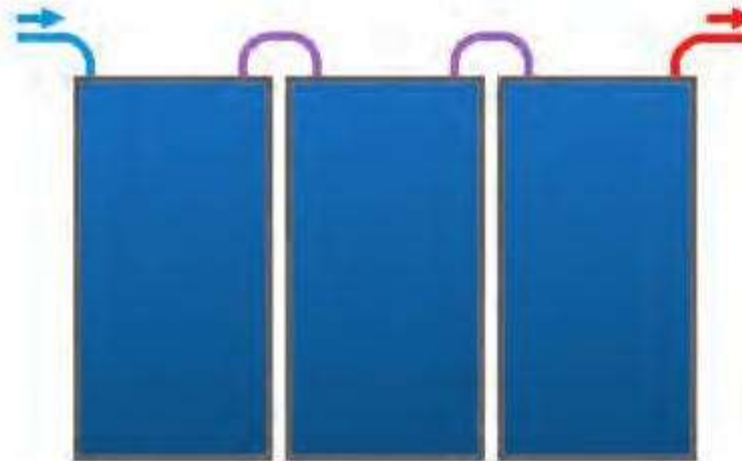

Figure 4.39.
Series connection

COMBINATION OF SERIES AND PARALLEL CONNECTIONS

Such combinations make it possible to combine the advantages of both connection principles. By successively connecting collectors, the flow resistance in the individual rows is significantly increased over that of the header pipes. It is then possible to dispense with a Tichelmann connection and the related long pipelines. The objective of combination connections is a uniform flow through the collector fields with a low flow resistance (low pumping power).

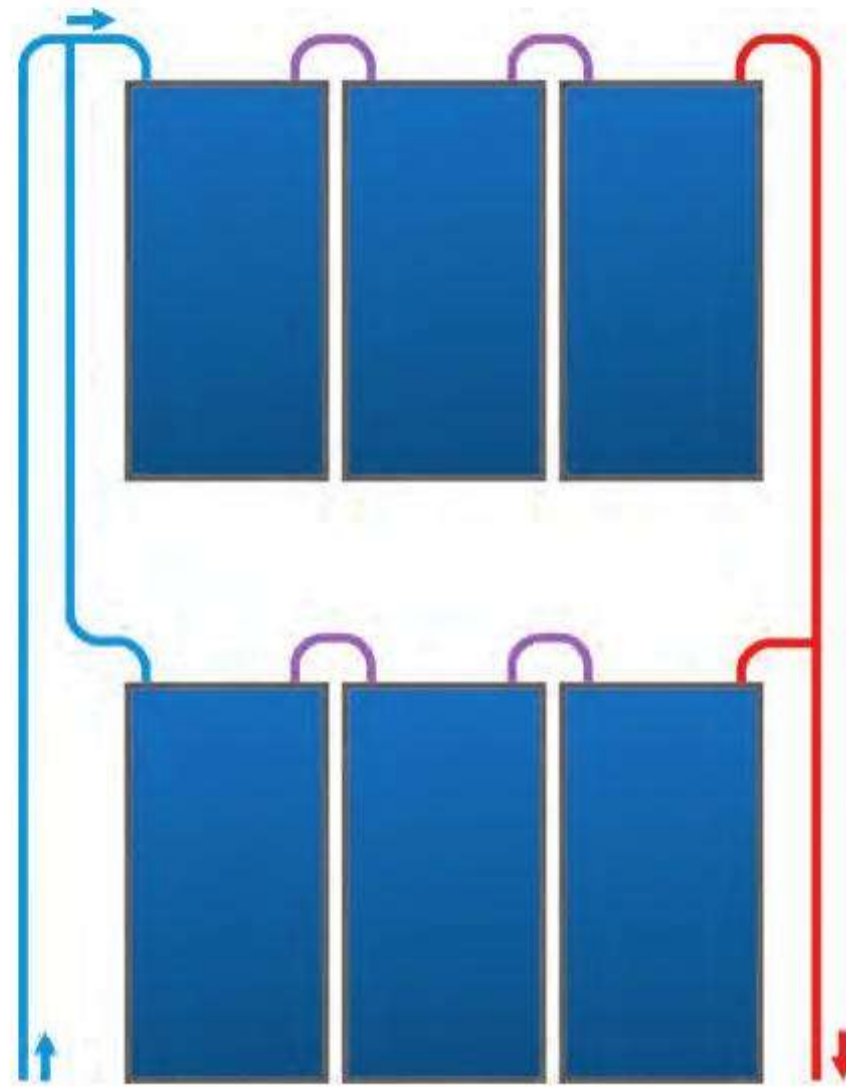

Figure 4.40.
Combination series and parallel
connection

4.3.4 Installation of the solar circuit

The well-proven materials and connecting techniques used for classical heating and sanitary fittings can be used for installing the solar circuit, as long as they meet the following requirements:

- Temperatures of over 100°C (212°F) may arise.
- The solar medium is a water–glycol mixture in the ratio 60:40 (Central Europe).
- Fittings are sometimes mounted externally.

Other points to note:

- With such high temperatures, plastic tubes cannot be used because of their poor temperature resistance.
- Glycol in connection with zinc leads to the formation of slime.
- The use of steel tubes is possible in principle, but they are expensive to process (welding, bending, cutting, cutting threads, applying hemp). They are used for larger solar energy systems.
- Stainless steel corrugated pipe is rarely used. It is mainly used for self-build installation, as in this case it is possible to dispense with soldering. In any case it is more expensive than copper pipe.
- Copper pipes have become popular for small systems. Common types of connection are hard and soft soldering. Various solders and fluxes are available for this (see section 4.2.5).

Soft soldering is permitted up to a permanent temperature load of 110°C (230°F). As higher temperatures are present in the solar circuit, hard soldering is frequently demanded. In practice, however, it has been found that soft soldering is mainly used for solar energy systems for one- and two-family homes with success. That is not surprising, as temperatures of more than 110°C (230°F) outside the collectors seldom occur (exception: pipes near the collectors). On the other hand large solar energy systems, especially those with evacuated tube collectors, should always use hard solders.

The advantages of soft soldering are as follows:

- The material load is lower than with hard soldering.
- Soft soldering is quicker.

Further connecting techniques are:

- *Press fittings.* Using a pressing clamp, the press fittings (made of copper with sealing elements of EPDM) cannot be released, and are linked with the copper pipe. This technique is also used for stainless steel pipes.
- *A clamping ring connection.* This is a releasable screw connection, which is reliable, and temperature- and glycol-resistant.

What needs to be considered when installing the pipes?

- Select the shortest possible paths.
- Lay the lowest possible length of pipe in the external area (high heat losses, more expensive thermal insulation).
- Allow sufficient space for retrofitting the thermal insulation.
- Provide ventilation options (a sufficient number with good accessibility).
- Make sure that the system can be completely emptied.
- In the case of long straight pipe runs (from approximately 15 m (49.2 ft) install expansion bends.
- Provide sound insulation.

4.3.4.1 THERMAL INSULATION OF PIPES

The heat gained in the collectors has to be delivered to the store with as few losses as possible. The thermal insulation of the pipes is therefore very important (see Heat Losses in Piping and Stores in section 3.5.2.5).

Essential factors are:

- sufficient insulation thickness (up to DN20: 20 mm (0.8 inches), from DN22 to DN35: 30 mm (1.2 inches); for greater diameters up to 100 mm (3.9 inches) the insulation thickness equals the nominal width of the pipe, with thermal conductivity, $\lambda = 0.04 \text{ W/mK}$)
- no gaps in the insulation (also insulate fittings, tank connections etc.)
- correct selection of material (temperature resistance, UV and weather resistance, low heat capacity values).

Table 4.5 lists heat-insulating materials with high temperature resistance.

Table 4.5.
Heat-insulating materials with high temperature resistance

Make	Max. temp.	λ value (W/mK)	Remarks
Aeroflex	150°C	0.040	Not UV-resistant
Armaflex HT	170°C	0.045	Not UV-resistant
Mineral wool, insulating shells	>250°C	0.035	Sensitive to moisture

When pipes are installed in closed ducts, as in a chimney for example, the heat insulation should be installed before the pipes are inserted. When installing unslit over the pipe (to avoid gluing) insulating ‘hoses’ are pulled over the pipes before soldering. They should be pushed back and retained, for example with a gripper, in order to protect them from damage by heat. After soldering and cooling, the gripper can then be removed, the insulating hose pulled back to its original length and any gaps closed.

In the external area they are best protected by a metal jacket (galvanized steel plate, aluminium) from moisture, UV radiation and bird damage.

Pipe installation options are as follows:

- installation in a redundant chimney shaft/supply shaft
- installation through the individual floors (surface or flush mounted); ceiling openings are required here, and special care is required in the case of underfloor heating
- installation below the roof skin, down the façade (for example in a downspout), through the outer wall or into the cellar.

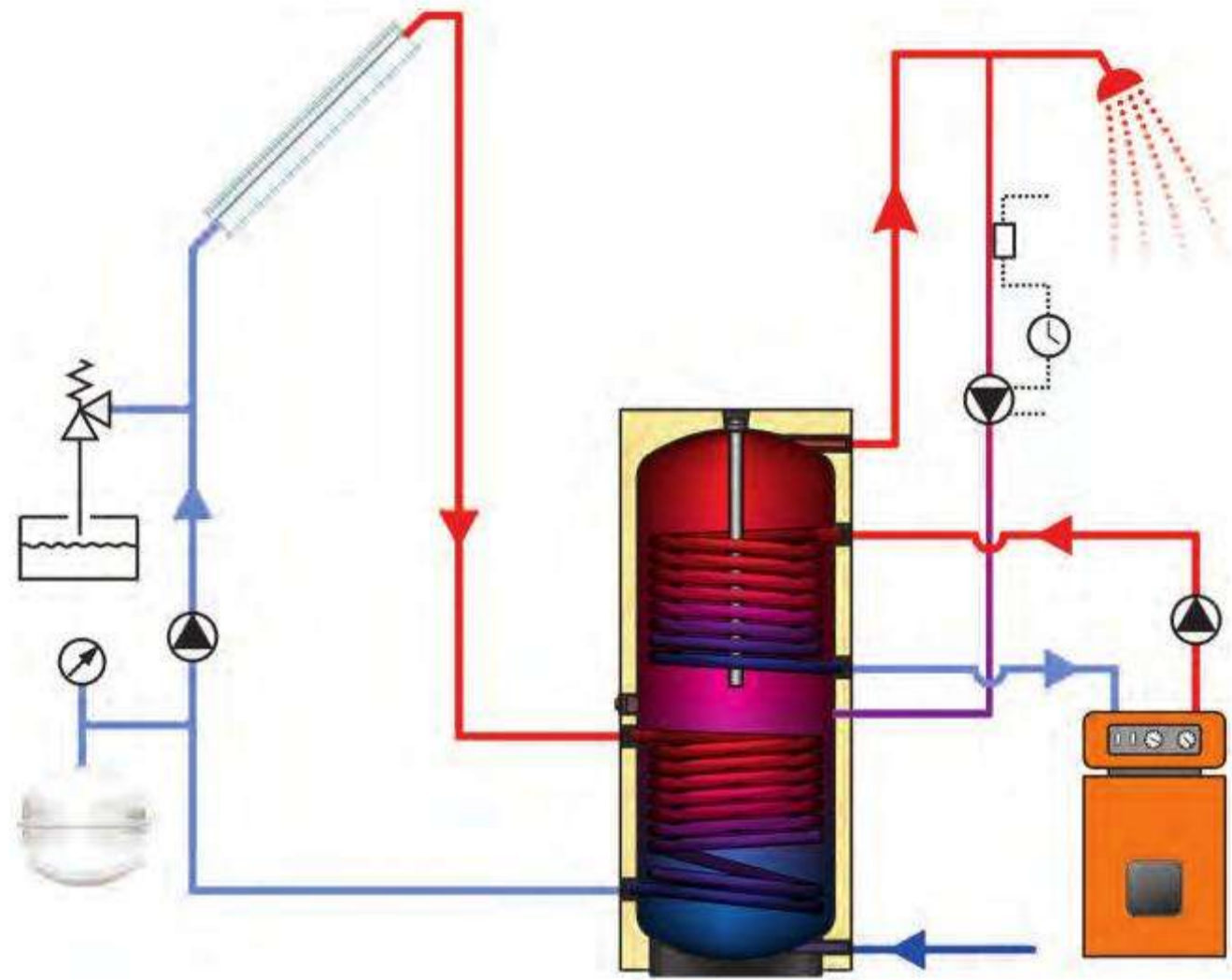

Figure 4.41.
Twin-coil system with domestic water storage tank

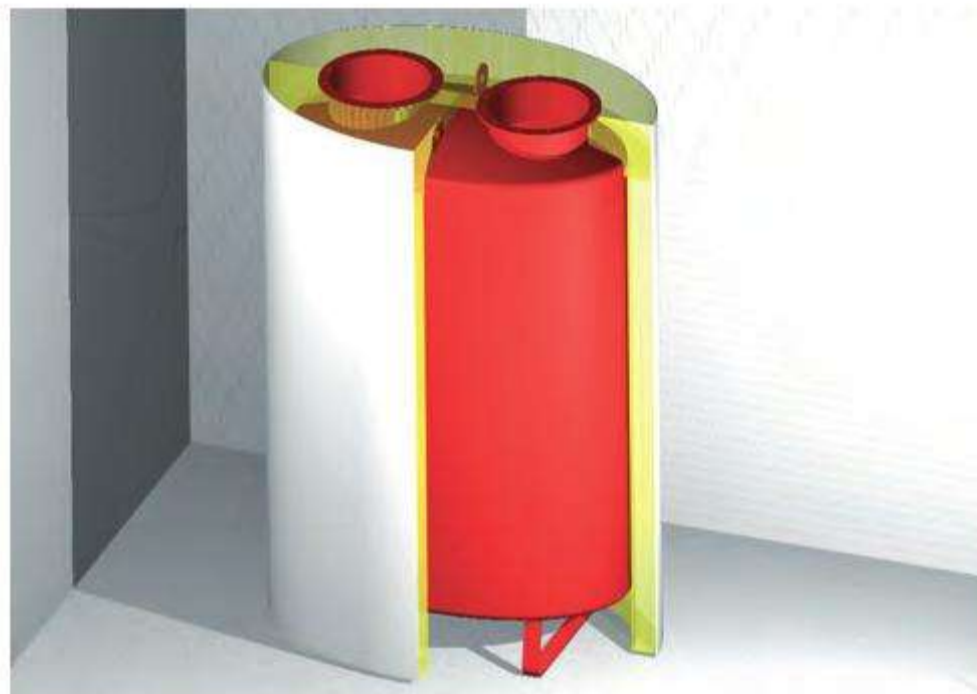

Figure 4.42.
The Hybrid XXL Power oval thermal store for narrow doors. Manufacturer: Sailer Solar Systems, Blaubeuren

For low-flow systems the twin tube is frequently used. This is a thermally insulated double pipe made of soft copper from the roll with integrated sensor cable (see Chapter 2, section 2.4.1).

4.3.5 Store installation

The loading capacity of the floor has to be considered (store weight including the water volume). If the store is mounted on the ceiling, the ceiling may have to be strengthened or the load be distributed if necessary.

The diameter of the tank is restricted by the smallest door on the way to the installation location. Removable thermal insulation is an advantage, as the store is narrower and can therefore be transported more easily. Enamelled tanks are sensitive to impact. The height of the tank is determined by the free height at the installation location, because waste water or heating pipes can reduce the height. The dimension of the store when tilted must also be considered.



Figure 4.44.
 Connection and thermal insulation
 of a solar store
 Source: Wagner and Co., Cölbe

4.3.5.1 CONNECTION OF SOLAR CIRCUIT

The solar circuit is always connected to the lowest heat exchanger (when more than one heat exchanger is used), as the whole store needs to be available during high insolation. In this position it is also in the coldest area of the store, which increases the efficiency of the solar system.

TYPES OF HEAT EXCHANGER

- *Permanently installed internal plain tube heat exchanger.* The solar feed pipe is connected to the upper tapping, the solar return pipe to the lower one: that is, the solar medium flows through the tank in parallel with the temperature layers in a counter-flow to the convection flow in the tank. Sometimes they are also mounted the other way round, which would lead to uniform heating of the standby area but lower efficiency.
- *Permanently installed internal copper-finned tube heat exchanger.* The fins increase contact with the storage water.
- *External plate exchanger.* This requires a separate pump and control.

Figure 4.44 gives examples.

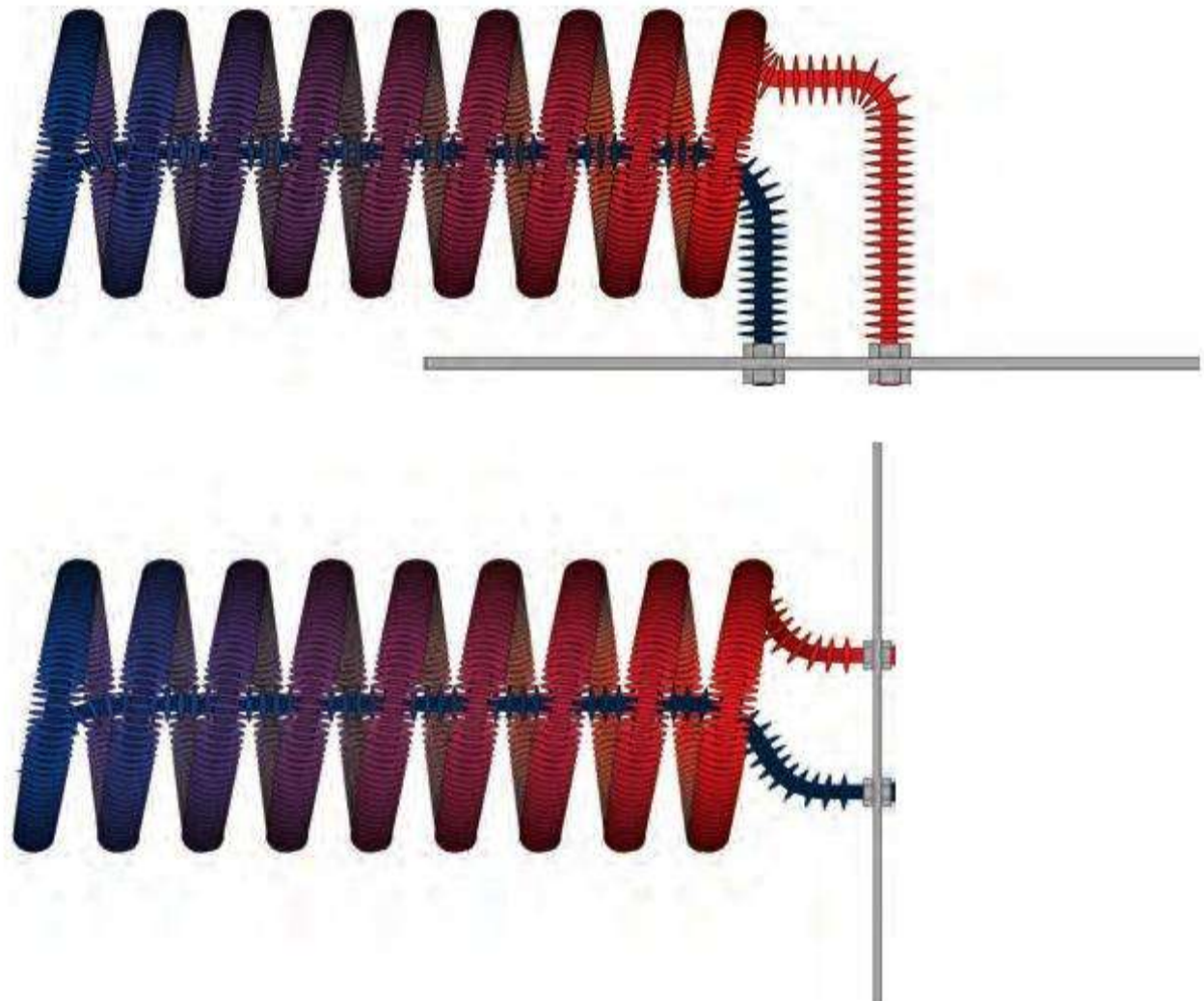

Figure 4.44.
Top: Finned tube heat exchanger,
cranked. Bottom: Finned tube heat
exchanger, horizontal

4.3.5.2 CONNECTIONS FOR ADDITIONAL HEATING SYSTEM

The additional heating system(s) is always connected to the upper heat exchanger(s) to ensure that peak demands can be met without solar gain.

4.3.5.3 COLD WATER CONNECTION

The cold water connection is installed at the bottom of the store. For unvented stores, the inlet combination, consisting of shut-off valve, non-return valve and safety valve, should be installed in the cold water pipe. If necessary an additional pressure reducer should be installed (if needed to reduce the mains pressure). The safety valve must be installed so that it cannot be shut off.

To reduce water losses through the safety valve during the charging process it is also mandatory to install either a membrane expansion vessel or internal bubble top which is suitable for domestic water.

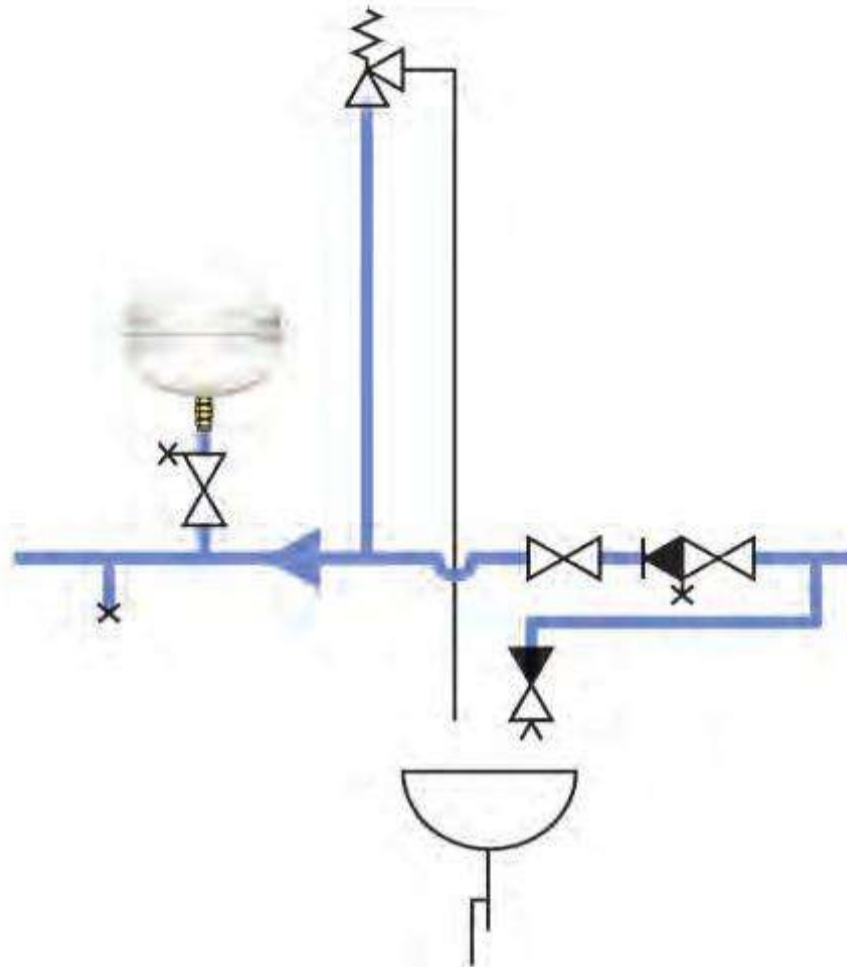

Figure 4.45.
Cold water connection with fittings

4.3.5.4 HOT WATER CONNECTION AND INSTALLATION OF SECONDARY CIRCULATION

The hot water connection is usually at the top of the store. A hot water mixer should normally be installed to provide protection from scalding.

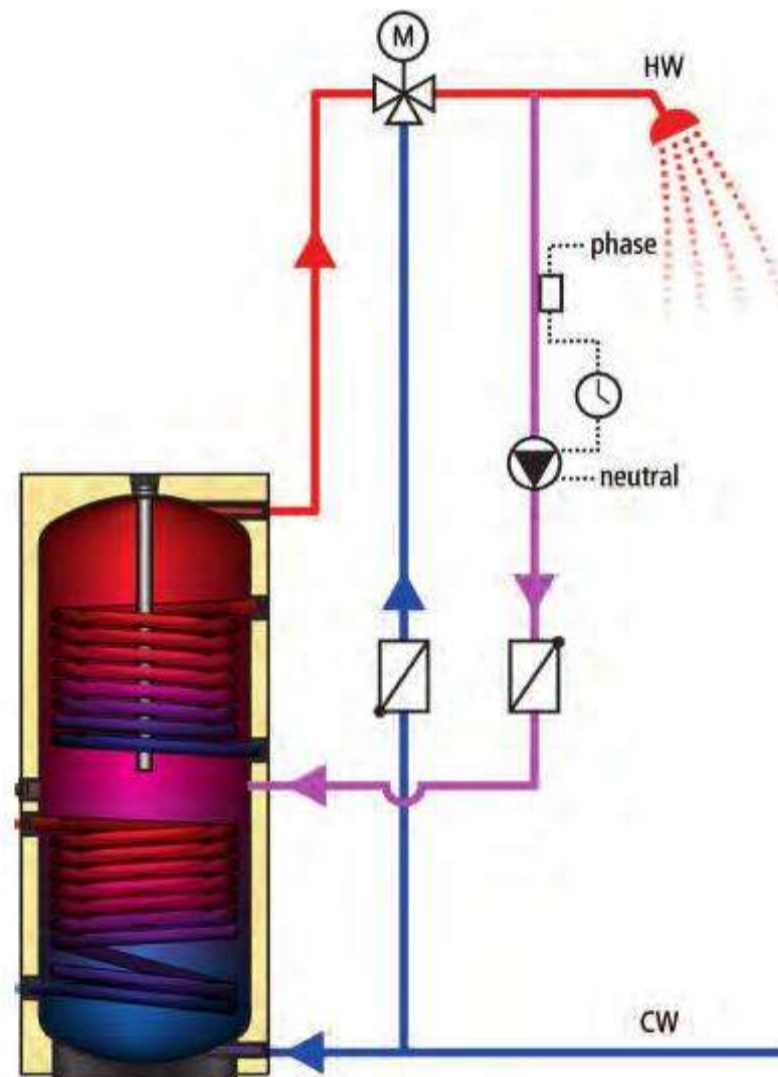

Figure 4.46.
Hot water connection with all fittings and secondary circulation

Secondary hot water circulation always impairs the necessary temperature layering effect in the store. It should therefore be led back at the half-height level of the tank, and must never be connected to the cold water feed line. This would lead to complete mixing of the whole tank. (The exception to this is special circuits that heat up the whole installation periodically to prevent Legionella contamination.)

To reduce secondary circulation heat losses, there are a number of options in addition to 100% thermal insulation:

- installation of a time clock
- installation of a thermostat
- installation of a bypass pipe with temperature-controlled three-way valve between the circulation and the hot water pipe

- installation of a sensor
- installation of a pressure switch/flow monitor.

4.3.5.5 INSULATION OF THE STORE

The quality of the thermal insulation strongly influences the performance of the whole system. Hence some manufacturers supply excellent insulating materials. Apart from PU rigid foam shells, which cannot fit closely enough to the tank to provide a good heat seal, the materials used vary from CFC-free PU flexible foam jackets to, even better, EPP or Melamine resin flexible foam with a value of $0.035 \text{ W/m}^2\text{K}$ (see Chapter 2, section 2.3.2.5 and Figure 4.47).

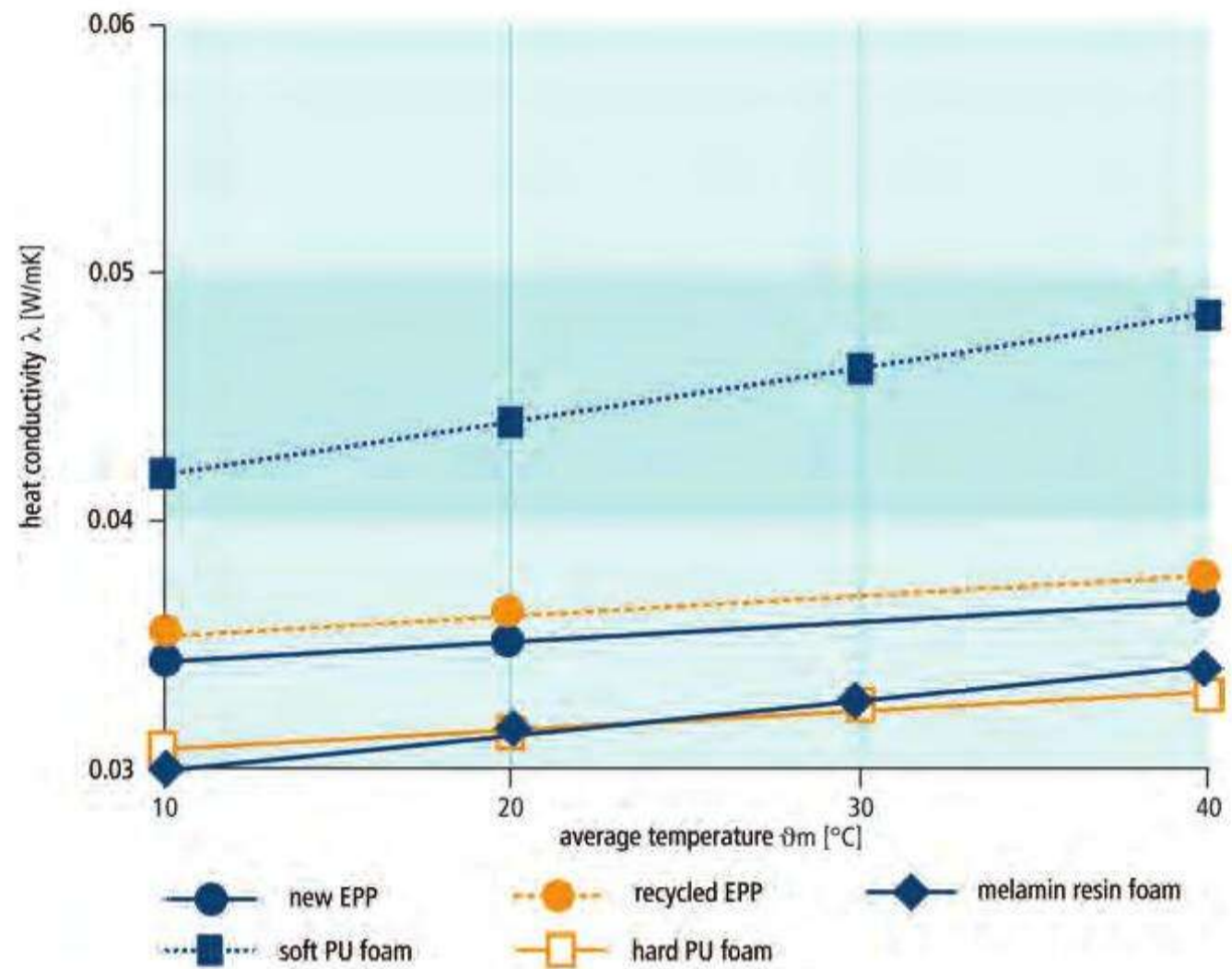

Figure 4.47. Thermal insulating values (EPP: Expanded polypropylene)³⁶

Apart from using a high-quality insulating material it is also important to ensure good installation:

- Use thermal insulation for the base area of the tank.
- Use a closely fitting insulating jacket.
- Reinforce the upper cover thickness to a minimum of 15 cm (5.9 inches).
- Insulate without gaps the pipe connections, flanges and stoppers.

Tanks of 300–400 l (79.3–105.7 gallons) capacity are frequently supplied ready insulated (with hard PU foam) and jacketed. PU foam has good insulating properties. It must, however, be fitted tightly, otherwise the tank will be cooled to by air circulation.

The side connections on the tank are fitted with either a convection brake (Figure 4.48) or a syphon arrangement to reduce heat losses through cooling in the pipe and self-induced circulation.

4.3.5.6 INSTALLATION OF OTHER STORE TYPES

Combined stores, stratified, direct and single-coil stores with a downstream-compatible direct heater are sometimes installed. If there is any doubt about the best option, the manufacturer's technical advice service should be contacted. This is always better than having to modify the system later when it is found not to function correctly.



Figure 4.48.
Convection brake. Manufacturer: Wagner
& Co., Cölbe

4.3.6 Installation of fittings

4.3.6.1 FITTINGS IN THE SOLAR CIRCUIT

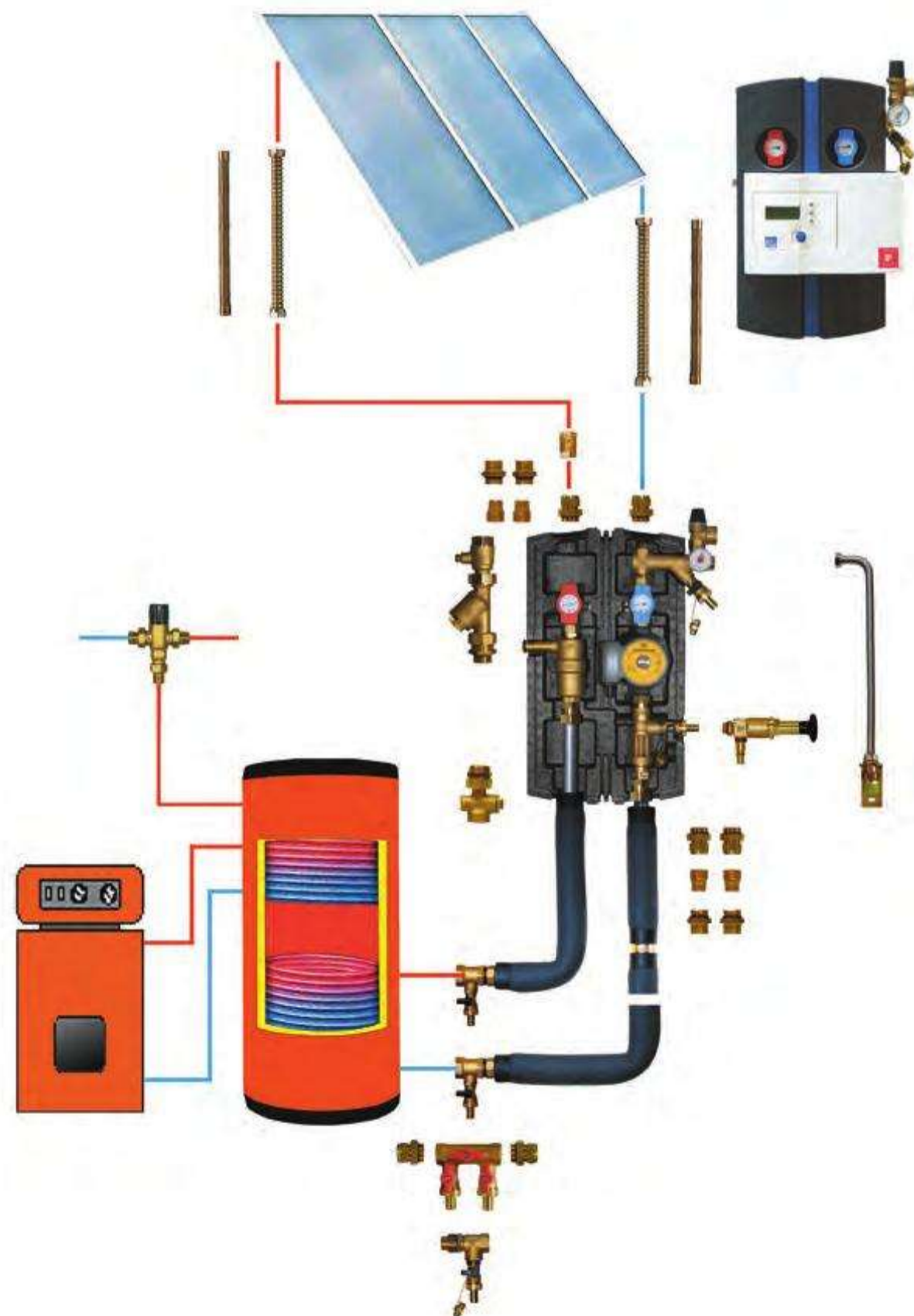

Figure 4.49.
The armatures of the solar circuit
(Pommerening Armaturenwerke,
Hameln)

COMBINED FILLING AND EMPTYING TAPS

Draining valves should be installed for filling and emptying, as well as for flushing the system at the lowest point of the feed and return pipes. Each one should be equipped with a hose connection.

CIRCULATING PUMP

The pump is installed in the return flow line so that the thermal shock remains as low as possible. It should be fitted between two shut-off valves (pump gate valves, ball valves) so that it can easily be removed. It should be arranged so that the heat transfer medium can be transported vertically from bottom to top: hence included air can flow upwards and escape through the air vent. The pump must be installed without any mechanical stresses.

RETURN-FLOW PREVENTER (CHECK VALVE)

To prevent convective liquid circulation from taking place in the solar circuit when the circulating pump is switched off, which would withdraw heat from the store and transfer it to the surroundings via the collector field, the solar circuit is fitted with a return-flow preventer. If possible this should be mounted immediately downstream of the circulating pump. Since with larger tube cross-sections so-called single-pipe circulation can take place, many manufacturers recommend the installation of a second return-flow preventer in the feed line. The return-flow preventer must be capable of being opened for flushing and emptying the solar circuit.

EXPANSION VESSEL (MEV)

The expansion vessel is fitted to absorb the volume increase in the solar liquid when heated, and to return it again to the system when it cools down. It should be selected to be large enough so that it can additionally take up the whole liquid volume in the collectors and, in the case of evacuated tube collectors, also a portion of the content of the feed and return lines. This ensures that during stagnation the solar liquid is not released (inherent safety). The expansion vessel should be suspended in a non-insulated branch of the solar circuit return line in order to reduce the thermal load of the membrane. The lower side with the valve must be accessible for checking and for setting the admission pressure. Expansion vessels with volumes greater than 12 l (3.2 gallons) are fixed with their own retainers. Before installation the admission pressure, p_{adm} , should be set;

$$p_{adm} = h_{sys} \times 0.1 \text{ bar/m} + 0.5 \text{ bar}$$

Example:

System height, $h_{sys} = 7\text{m}$ (distance between MEV and top edge of collector)

Hence $p_{adm} = 7 \text{ m} \times 0.1 \text{ bar/m} + 0.5 \text{ bar} = 1.2 \text{ bar}$

An admission pressure of 3 bar is usually set in the factory, so that the required value can be set by releasing a corresponding amount of gas with a pressure tester. A pressure pump containing nitrogen is used to increase the admission pressure.

SAFETY VALVE

In order to prevent a non-permitted pressure increase in the solar circuit, the installation of a safety valve is specified. When the response pressure is reached the valve opens and releases solar liquid. This response pressure must not exceed the maximum operating pressure permitted for the collector and the expansion vessel. The safety valve has to be mounted in such a way that it cannot be shut off with respect to the collectors: that is, the solar circuit leg between the safety valve and the collectors must be free of shut-off elements. The safety valve should be installed in a vertical position, and a pipe should be led down from its blow-off opening into a container, in which the escaping solar liquid can be collected.

VENTS

Frequently, after filling the system, trapped air is found at various points in the solar circuit. In addition, air in dissolved form is found in the solar liquid, which is released again upon heating. The trapped air gathers at the highest points of the piping system.

If no countermeasures are taken this would impair the liquid circuit. It is therefore necessary to install vents. If automatic vents are used it must be ensured that the selected version is suitable for the maximum temperatures occurring at the installation site and suitable for the antifreeze. Vents for temperatures up to 150°C (302°F) can be obtained for this purpose. Vents installed close to the collectors must be fitted with a shut-off element (ball valve) because of possible vapour escapes. Vents are mainly installed at the highest point of the system (see Chapter 2, section 2.4.6). Good accessibility must be ensured. If air locks can form at particular points of the solar circuit additional vents should be installed.

AIR SEPARATORS

Air separators are built into the solar liquid circuit. They increase the flow cross-section, thereby reducing the flow speed and permitting the air bubbles to rise. These can then escape through an installed vent (see Chapter 2, section 2.4.6). Versions are available for horizontal and vertical mounting.

DISPLAY INSTRUMENTS (THERMOMETERS, PRESSURE GAUGES, FLOWMETERS)

To monitor the operation of the system, the display of the solar feed temperature and the operating pressure (with identification of the maximum permitted pressure) is specified. The pressure gauge should be installed so that it can be read when the system is filled. Furthermore, display instruments are recommended to show the solar return temperature and the volumetric flow rate in the solar circuit.

SHUT-OFF FITTINGS

Various versions of shut-off fittings exist, including angle and straight seat valves, ball valves, slide valves, and butterfly valves. When installing the valves it is important to note the direction of flow. Ball valves possess the lowest flow resistance.

DIRT FILTERS

The use of a dirt filter can be dispensed with for small systems (soft soldered) and suitably flushed solar circuits. Their installation is recommended for hard-soldered systems as, over time, loosening scale can impair the function of particular components (pumps, safety valves, gravity brakes, mixing valves). The dirt filter should not be 'hidden' beneath the thermal insulation but should be easy to find and accessible for maintenance work.

4.3.6.2 FITTINGS FOR DOMESTIC HOT WATER PIPING

DRAIN TAP

For emptying the store during maintenance work and repairs a drain tap should be installed at the lowest point of the cold water feed pipe.

THERMOSTATIC MIXING VALVE

Because of the high storage tank temperatures (>60°C; 140°F) that arise during favourable weather conditions, it is necessary to limit the maximum water temperature to protect the system user from scalding. In some countries higher temperatures are allowed, but for solar water heaters it is always recommended to install a thermostatic mixing valve between the cold and hot water pipes to limit the output temperature. A characteristic of a solar water heater is that sometimes the delivered water may be much hotter than at other times. Users might become accustomed to a certain temperature and burn themselves when suddenly the temperature out of the tap is much higher, for example after a period of high solar irradiation and low consumption.

The connections of the mixing valve are marked, and must not be exchanged. The maximum temperature can be set on the mixing valve. This should be the same as the set temperature on the additional heating. As already said, in some countries the supplementary heater may be set at 45°C (113°F), whereas in other countries the water temperature must be at least 60°C (140°F) because of Legionella regulations. If the storage tank water is warmer, cold water is added. It is also recommended that a thermometer is installed after the mixing valve.

DIRT FILTER

The function of the thermostatic mixing valve and the pressure reducer can be impaired by small particles. It is therefore recommended that a dirt filter is installed in the cold water pipe upstream of these fittings in the flow direction.

4.3.7 Installation of sensors and controllers

All work on electrical equipment must be carried out according to the appropriate regulations.

4.3.7.1 INSTALLATION AND CONNECTION OF SENSORS

The correct installation of sensors is an important precondition for the trouble-free functioning of a thermal solar energy system. The correct location and a good thermal contact are equally important (firm seating, thermal conducting paste):

- The collector sensor is either fixed directly onto the absorber (usually it is premounted in the factory), or installed in an immersion sleeve at the hottest point in the collector feed. When laying cables, care should be taken to ensure that the cables do not come into contact with the hot pipes.
- The store sensor should be fitted at the height of the solar circuit heat exchanger. This is either done with the help of a clamping bar, which is attached to the outside of the store wall and is covered by the tank's thermal insulation, or it is fitted in an immersion sleeve made of brass or stainless steel.

If the cable lengths of the temperature sensor are insufficient they must be extended with a cable with a minimum cross-section of 0.75 mm². The cross-section depends on the length, and can be found in the manufacturer's documentation.

Sensor cables should not be laid together with mains grid cables in a pipe or cable duct, as the electromagnetic fields will influence the measured values. In addition, a sensor-connecting socket should be installed with excess voltage protection (lightning protection socket).

4.3.7.2 CONTROL UNIT INSTALLATION

The housing should first be attached to a wall in the vicinity of the solar station. According to the connection assignment (circuit diagram) the temperature sensors (collector and tank sensors) as well as the solar circuit pump should all be connected to the respective terminals on the terminal strip of the solar control unit. After that, the mains connection is made and the housing is closed; the controller can then be started up.

Before opening the control unit housing it is important to ensure that it is isolated from the mains voltage.

4.4 Starting up, maintenance and servicing

The necessary steps to start up a thermal solar energy system are:

1. Flush out the solar circuit (Figure 4.50).
2. Check for leaks.
3. Fill with solar liquid.
4. Set pumps and controller.

4.4.1 Flushing out the solar circuit

A thorough flushing process removes dirt and residual flux from the solar circuit. Flushing should not be carried out in full sunshine or during frost, as there is a risk of evaporation or freezing. The flushing process initially takes place via valves 1 and 2 (see Figure 4.50). Valve 1 is connected to the cold water line by a hose; a further hose on valve 2 is laid to the drain. All fittings in the solar circuit should be set to through-flow (gravity brake, shut-off taps). Finally, in order to flush out the heat exchanger valve 2 is closed, after attaching a hose to it valve 4 is opened, and valve 3 is closed. The flushing process should last for about 10 minutes.

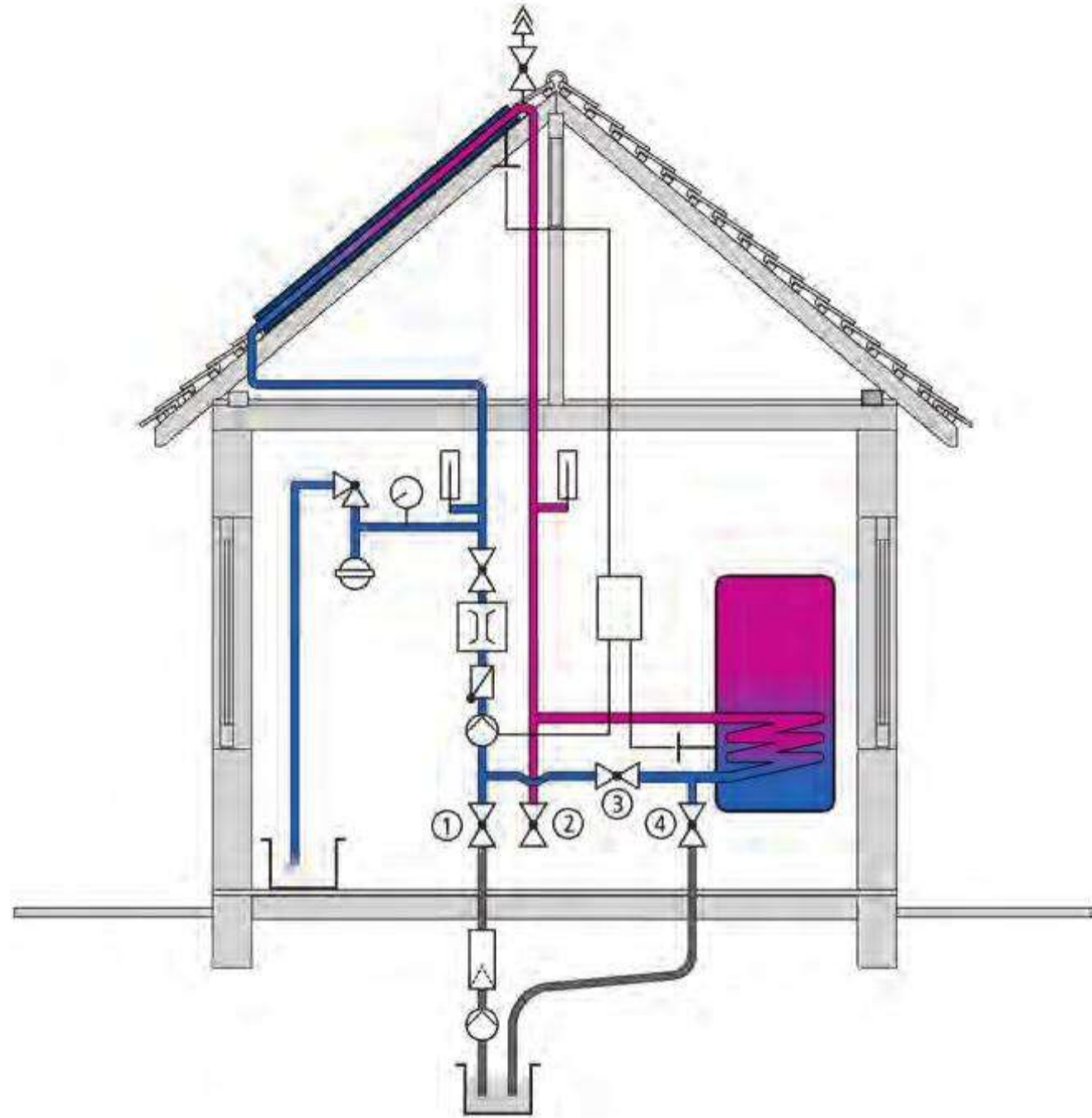

Figure 4.50.
Solar circuit with fittings for flushing and
filling–flushing process.³⁷

4.4.2 Leak testing

The pressure test takes place after flushing. For this purpose valve 4 is closed, and the system is filled with water through valve 1. The system pressure is then raised to a value just below the response pressure of the safety valve – maximum 6 bar (87 psi). Then valve 1 is closed, the pump is manually started, and the solar circuit is vented via the vents or the pump (vent screw). If the pressure falls significantly as a result of bleeding, it must be increased again by additional filling. The system is now ready to be tested for leaks (visually and by hand). A leak test using the pressure gauge is not possible because of irradiation-caused pressure variations over the course of a day. At the end of the leak test the function of the safety valve can be tested by increasing the pressure further. The solar circuit should finally be fully emptied again by opening taps 1 and 2. By measuring the amount of water that runs out it is possible to establish the amount of antifreeze required to make up a water–antifreeze mixture of for example 60:40. As some water always stays in the solar circuit (for example in the collectors or the heat exchanger) the measured amount of water should be correspondingly increased.

4.4.3 Filling with solar liquid

After mixing the antifreeze concentrate with water to achieve the desired level of frost protection (or using pre-mixed antifreeze) the solar liquid is pumped into the solar circuit through valve 1. As the solar liquid – compared to water – is much more likely to creep, it is necessary to recheck the system for leaks. A general procedure to release the air from the solar liquid is as follows – but always check the installation instructions for the specific product, as differences may occur.

1. When pumping the solar liquid into the system and the mixing container, a large part of the air is already removed. To be effective the ends of the hoses must be completely submerged in the liquid. When no more air bubbles come out, valve 4 can be closed.
2. Reduce the pressure to system pressure (= static pressure + 0.5 bar (7.25 psi)) plus an allowance for pressure loss through further bleeding.

3. Switch on the circulating pump. Switch it on and off several times at 10 minute intervals.
4. To bleed the circulating pump, unscrew the brass screw on the face.

An alternative method of bleeding the system can be used where there does not need to be a top vent. The high rate of flow takes the air bubbles down with it again. The system is bled in this case via a vent bottle, which is integrated into the feed line of the solar station. In this bottle the relatively high flow rate of 60 l/m²h (1.5 gallons/ft²) is severely reduced owing to the increase in cross-section. The air gathering in the upper area of the vent bottle can be discharged through a manual vent.

If the pressure falls below the system pressure as a result of bleeding, solar liquid should be added accordingly. After several days the shut-off tap under the vents is then closed.

4.4.4 Setting the pump and controller

The volumetric flow in small systems is usually about 40 l/m²h (0.98 gallons/ft²) (high-flow operation); in systems with stratified stores it is 15 l/m²h (0.37 gallons/ft²) (low-flow operation). The pump should be capable of generating the pressure required in its medium performance range. With full irradiation, this leads to a temperature difference between the feed and return lines of about 10–15 K in high-flow operation and 30–50 K in low-flow operation. The actual volumetric flow can be controlled with the help of a tacho-setter or a flowmeter.

The switch-on temperature difference of 5–10 K and the switch-off difference (hysteresis) of about 2 K should be set on the controller. In this way, on the one hand the heat generated in the collector is transferred to the store at a useful temperature level, and on the other hand no unnecessary pump energy is used.

4.4.5 Maintenance

Solar thermal systems require very little maintenance; however, a regular check is recommended.

During the course of maintenance the users should be asked about their level of satisfaction. The maintenance work is described in a maintenance report, and should contain the following in detail:

4.4.5.1 VISUAL INSPECTION

The visual inspection involves checking the collectors and the solar circuit for visual changes:

- *collectors*: contamination, fixings, connections, leaks, broken glass, tarnishing on panes/tubes
- *solar circuit and storage tank*: tightness of thermal insulation, leaks, check/clean any dirt traps, pressure, filling level.

4.4.5.2 CHECKING THE FROST PROTECTION

The frost protection of antifreeze fluids is checked with a hydrometer or refractometer. For this purpose a given amount of solar liquid is removed. Either the temperature to which the system is protected is shown directly, or a specific density is read off. This allows the actual content of antifreeze mixture to be established from a density–concentration diagram, and thereby the freezing point.

For drainback systems, the level of the collector fluid needs to be checked: if necessary fill the circuit to its proper level.

4.4.5.3 CHECKING THE CORROSION PROTECTION

SOLAR CIRCUIT

Checking the corrosion protection of the solar liquid (if it contains antifreeze liquid) is done indirectly by establishing the pH value. Test strips are suitable for this with which the pH value can be read from a colour scale. If the pH value falls below the original value (as should be mentioned in the commissioning report of the installation) or to under 7, the frost protection mixture should be exchanged.

STORE TANK (ONLY FOR TANKS WITH ANODES)

The magnesium sacrificial anode can be tested by measuring the current between the detached cable and the anode using an ammeter. If the current is over 0.5 amps, there is no need to renew the anode. In case of a powered anode, only the LED indicating proper functioning needs to be checked.

4.4.5.4 MONITORING THE SYSTEM PARAMETERS

The pressure and temperature, and the controller settings, must be checked. During operation the system pressure varies, depending on the temperature. After complete bleeding it must not vary from the set value by more than 0.3 bar (4.4 psi). It must never fall below the admission pressure of the MEV vessel. The temperature difference between feed and return lines should in full irradiance conditions not exceed 20 K (otherwise there may be air in the solar circuit or blockages due to contamination – however, for low-flow systems the temperature difference may be higher) and not drop below 5 K (otherwise limescale will form in the heat exchanger) in high-flow systems. The controller settings and functions must be tested. If provided, within the scope of maintenance the data for system function and yield monitoring can also be recorded. Among these are:

- operating hours of the solar system pump
- quantity yield.

The solar circuit pump should have an approximate annual running time according to the sunshine hours at the respective location (example: London 1700 hours).

4.4.6 Assembly errors

The following are the most salient and common defects when assembling, from the view of an expert. Apart from planning, the sources of error and causes for faults predominantly (39%) occur during installation.

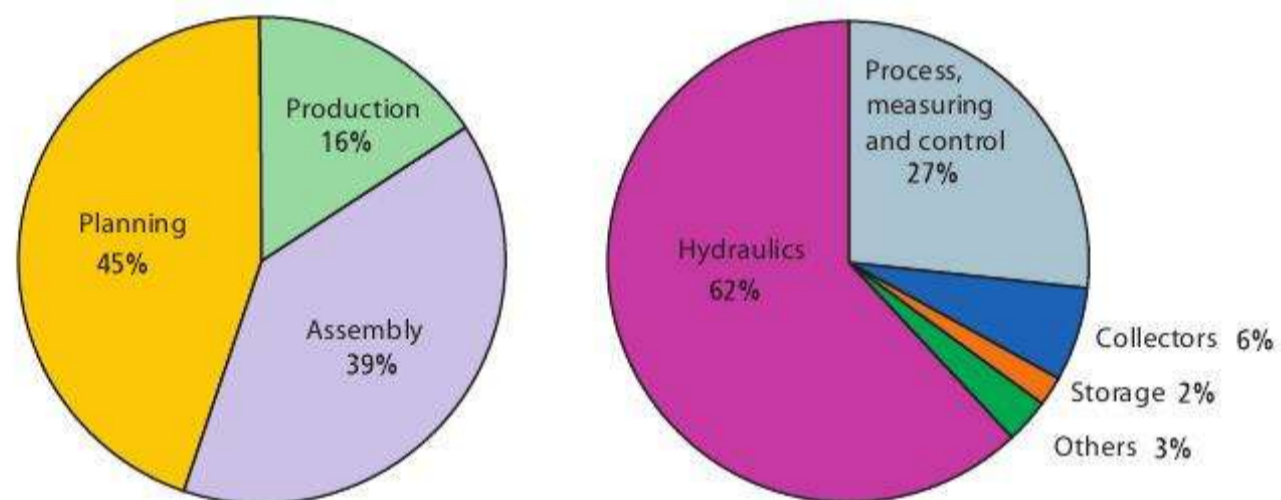

Figure 4.51 (left) Area production, planning and assembly; (right) Area system components and operation

If one regards the components or the operation of solar thermal systems, then the areas of hydraulics and MC (measuring and control) dominate the defect statistics.

The cause for defect is frequently lack of awareness of the few but substantial differences between conventional thermodynamics and the solar techniques.

These differences are clearly underestimated especially in planning and craftsman practice:

- Operating temperature of approx. -30°C to 250°C (-22 to 482°F)
- System yields dependent on accurate hydraulics and MC instrumentation
- Unregulated boiler, cannot be influenced in terms of timing or height.

The following figures indicate some of the particularly consequence-fraught deficiencies.



Figure 4.52
Break by ice formation



Figure 4.53
Damaged thermal insulation

BREAK CAUSED BY ICE FORMATION

Cause: Rinsing and pressure test of the system during winter with water. On the following frosty night it ice formed in the absorber pipe. Consequence: Tubing breaks and collector damage.

DAMAGED THERMAL INSULATION

Cause: Application of neither temperature nor weatherproof thermal insulation with maximum admissible temperature of 120°C (248°F). Consequence: Destruction of the insulating material and high calorific losses.



Figure 4.54
Incorrect PE pipe as exhaust line



Figure 4.55
Damaged propylene glycol

INCORRECT PE PIPE AS EXHAUST LINE

Consequence: The blowing-off process of the system via the safety valve melts the pipe and hot solar fluid can cause human injuries.

DAMAGED PROPYLENE GLYCOL

Cause: Excessive thermal load by too frequent system deadlock during high summer in connection with an enduring lack of maintenance led to early ageing of the heat carrier. Consequences: Chemical alterations of the heat carrier and loss of frost and corrosion protection.

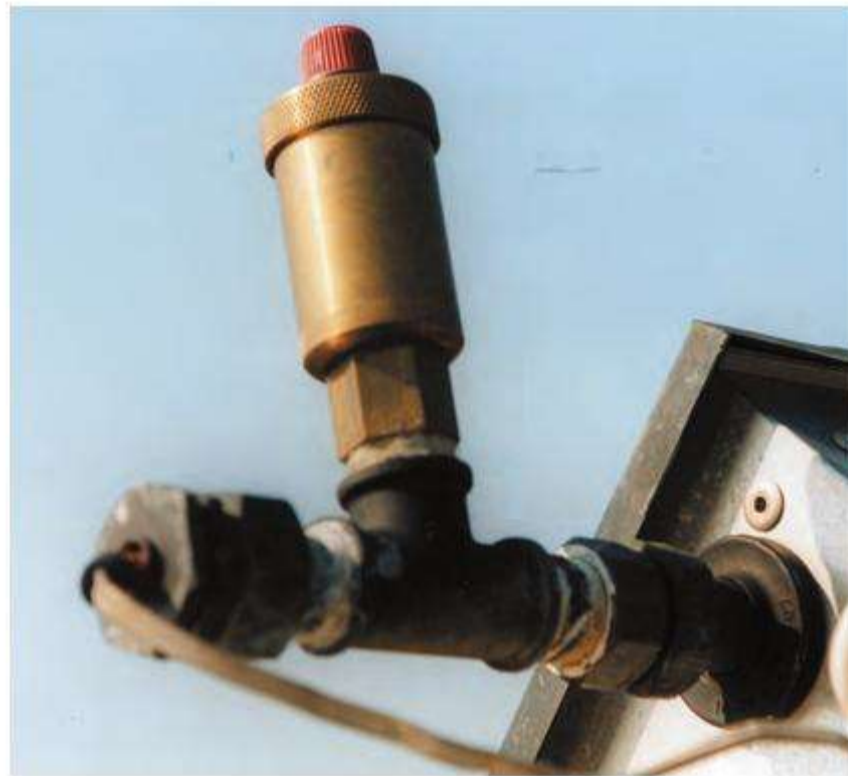

Figure 4.56
Unsuitable automatic air bleed and unclear sensor positioning



Figure 4.57
False expansion vessel connection from below

INAPPROPRIATE AUTOMATIC AIR BLEED AND UNCLEAR SENSOR POSITIONING

The assigned air bleeder of the heating unit is approved for temperatures up to 110°C (230°F). However, clearly, higher temperatures can occur in the collector. The positioning of the temperature sensor is situated outside the absorber. Consequences: Calorific losses via exhauster, destruction of the float and loss of fluid. Due to the unfavourable positioning of the sensor, the solar circuit pump switches on too late.

FALSE CONNECTION OF THE EXPANSION VESSEL FROM BELOW

Consequence: Through the hydraulic connection of the expansion vessel from below, air forms below the diaphragm that cannot escape and leads to clear pressure fluctuations in the solar circuit. Higher temperatures occurring in the return flow in conjunction with a single pipe circulation cause an additional thermal load of the membrane/partition.

Table 4.6
Assembly error, consequences and
their rectification

	Errors	Consequences/damage	Correction/prevention
General	Attitude of the technician that adherence to assembly instructions always offers protection in the case of damage	Possible damage	Knowledge of and adherence to generally acknowledged rules of the technology
Collector	Shaded collector	Smaller collector yield	If possible, placement on the roof in an unshaded position, otherwise increase collector area
	Shaded collector sensors	Regulator responds too late	Install last collector panel in shade-free area in direction of flow
	Use of different materials on the roof (copper above aluminium cover plates)	Risk of corrosion	Consider electrochemical potential
	Minimum overlap of pan tile/roof sheeting not considered (8 cm)	Roof leakage	Consider assembly instructions and minimum overlap
	Future accessibility of the roof complicated	Maintenance only possible with excessive effort	Guarantee accessibility
Solar circuit	Confusing feed and return pipe	Systems cycling, insufficient yields, possible destruction of the pump by overheating	Correct connection of feed and return pipes to the solar station
	Installation of inappropriate expansion	Diaphragm breakage, leaks, risk of bursting, blowing off via safety valve	Insertion of temperature-, pressure- and glycol-resistant expansion vessels
	Expansion of vessel connection from below	Air and steam accumulate in the expansion vessel, pressure fluctuations, diaphragm breakage	Expansion vessel connection from above
	Unsuitable air bleeder, missing temperature stability	Destruction by overheating also with locked ball valve (heat pipe)	Use of air bleeders approved to 150°C
	Non-compliance with temperature-, pressure- and glycol-resistance levels of the pipes	Leaks, glycol leaks	Use of temperature-, pressure- and glycol-resistant pipe material
	Missing flow-back valve in the solar feed line	Heat loss due to single-pipe circulation	Installation of temperature-stable flow-back valve in the solar feed line
	Missing exhaust pipe	Risk of scalding	Installation of copper exhaust pipe and connection with catchment tank
	Air separator not inserted	Air cannot separate, in extreme cases the complete cycle is interrupted	Install air separator
	Application of plate heat exchangers for swimming pool connection	Fouling, desoldering	Assembly of a tube bundle heat exchanger
Storage	Confusing feed and return port at the solar circuit heat exchanger	Poor heat transfer to storage water, smaller collector yield by too high return flow temperature	Install feed port at the storage above the return port
	Too high/low attachment or missing temperature sensors or no contact with the immersion sleeve wall	Bad regulation of the system, e.g. if support heating sensor is too low, despite sufficient storage temperature there will be no switching of the storage load (space heating remains cold)	Attach store sensors mid-height of the solar circuit heat exchanger/support heating. pay attention to good thermal contact (thermal compound/heat conductive paste)
	False hydraulic integration of the circulation line	Destruction of the layering/mixing	Correct integration of the circulation line (mounting at half store height)
	Missing tap water mixer	Risk of scalding	Fitting of a tap water mixer
Connection technique	Use of crimp connections with non-temperature resistant parts near the connector	Leakages (also after long periods)	Use of temperature-resistant parts, hard soldering/braze welding or clamp ring connections
	Sealing not done carefully enough (lower viscosity of glycol compared to water)	Leakages (also after long periods)	Careful joining technique. Leakage tests carried out after filling
	Soft soldering with evacuated tube collector systems	Solder softens at high temperatures leading to leakages, erosion (material removal)	Hard soldering/braze welding or clamp ring connectors
	Use of galvanized pipes and plastic tubes	Dezincification, sludge accumulation, leakages, loss of function	Copper, steel or high-grade steel lines
	Missing temperature-resistant transition from swimming pool heat exchanger to the plastic tube	Risk of changes	Thermal decoupling

Table 4.6 (continued)
 Assembly error, consequences and their rectification

	Errors	Consequences/damage	Rectification/prevention
Heat insulation	Too little/incomplete tubing insulation	Higher thermal losses	Continuous thermal insulation, insulation thickness as per Energy Saving Regulations
	Use of mineral wool in external areas	Dew point displacement, moisture entry, ice formation, increased thermal conduction, destruction of thermal insulation	Use of coated, closed-cell and temperature resistant thermal insulation (definitely no mineral wool in the external area)
	Missing steel coating	Bird damage	Aluminium coating
Control	Temperature difference settings too high	Smaller heat production	Temp difference settings according to manufacturer data (ΔT in ca. 5–7 K)
	Set value of max store temperature for domestic water stores >60 °C	Calcification of heat exchangers	Set maximum store temperature to 60°C
	Confusion of the sensor connectors of collector and store sensors at the regulator	System only switches on if store temperature is above collector temperature	Attach sensor cables correctly according to mounting instructions
Commissioning	Water remainders in the absorber and/or connection pipes (ice formation at 4°C air temp.)	Tubing breaks in absorbers and external piping possible	Compression test during times of freezing risk with heat carrier fluid or compressed air
	Proportion of antifreeze in the water/propylene glycol mixture is too high (> 50 %)	Poor heat transport, higher power consumption by pumps	Use of prepared mixtures or use a maximum of 40 % of propylene glycol
	No special heat transfer medium used for evacuated tube collectors	Highly accelerated ageing of heat transfer medium, possibly flocculation, increased maintenance costs	Use of special heat transfer mediums for evacuated tube collectors
	Fill in sunshine	Steam formation, complete filling not possible	Do not fill during strong sun exposure
	Poor de-aeration of the solar circuit, e.g. rinsing and filling process too brief (<15 mins) or air bleeder not at the highest point	Air in the solar circuit (pressure blows, no heat transport possible through blocking air bubble)	Professional de-aeration and air bleeding possibilities on all local high points
	Insufficient performance of filling pumps	Air in solar circuit(see consequences above), high commissioning costs	Use of centrifugal pumps and filling points of sufficient performance
	System pressure too low	Poor heat transport, up to interruption of the solar circuit	System pressure = static height + 0.5 bar
	Exhauster in collector proximity after line-up not locked	Stagnation and blow-off of the solar liquid possible	Close off the air bleeder
	Test report including signatures of manufacturer/ installer and operator/user is missing	Proof of the compression test and operability is missing, no standard transfer, guarantee time is unclear	Create test report
	Missing system layout in the furnace room	No quick overview possible for the operator and maintenance person	Attach system layout in the furnace room
Maintenance	Missing heat carrier check for protection against freezing	Tubing breaks in absorbers and external pipes possible	Freeze protection check with suitable measuring instrument (e.g. aerometer)
	Missing check for pH value	Corrosion and erosion of the pipes possible	pH-value check with measuring strip
	Refill using unknown heat carriers	Uncertain chemical properties	Exchange the heat carrier (rinse and possibly empty with compressed air)
Organization	Request for subsidies after placing order	Forfeiture of subsidies	Fill out application before placing order
	Communication problem between customer and installer	Installation turns out differently from what customer had imagined	Best possible correlation of customer's needs and system supplied
	Lack of coordination with the customer concerning other assembly sections	Disruption to building process	Timely and precise agreements between roofer, plumber and electrician and the customer

4.4.6.2 EXAMPLES OF FAULT DETECTION AND RECTIFICATION

SYSTEM PRESSURE DROPS

See Table 4.7.

- The better the system is vented when filled (by pumping the solar liquid through the system and through a tank filled with the same liquid until no more bubbles come out), the lower will be the number of faults caused by air in the system – and possibly no faults at all.
- Pressure variations of 1–2 bar (14.5–29 psi) due to temperature variations during system operation are normal. Pressure comparisons are only meaningful and useful for testing purposes at identical system temperatures.
- The system pressure should not decrease below the value of the static pressure + 0.5 bar (7.25 psi), as otherwise a partial vacuum could be created in the upper area of the solar system and air may be drawn in.

Table 4.7.
Fault detection – system pressure drops

Vent closed after filling and bleeding the system?	No	Close vent and increase pressure
Yes		
Solar liquid escaping from safety valve? (Check filling level of overflow container)	yes	MEV defective? (Knocking test) exchange if necessary
No		MEV shut off? (Not permitted) open if necessary
		MEV too small? Recalculate, install additional unit if necessary
		MEV admission pressure too high? System filling pressure too high? Reduce as necessary
		Incorrectly dimensioned safety valve? (Response pressure too low?) Exchange if necessary
Solar circuit leakproof? 'Feel' every soldering point and screwed connection with the fingers	No	Empty system, rectify leak(s), fill and bleed system

THE SUN IS SHINING BUT THE PUMP IS NOT RUNNING

See Table 4.8.

Other reasons:

- The store is hot, but below the maximum temperature. The sun's radiation is not sufficient to reach the switch-on temperature difference at high level. The behaviour of the system in this case is satisfactory.
- Twin storage tank system: the controller switches over to the hotter store, and the switch-on temperature difference has not yet been reached. Wait.

Table 4.8.
Fault detection – the sun is shining but the pump is not running

Is display on controller visible or does LED light up?	No	Controller has no voltage supply Check cable (power supply) and fuses
Yes		
Maximum store temperature reached?	Yes	Check maximum temperature Domestic water tank $\theta_{max} = 60^{\circ}\text{C}$ Buffer storage tank $\theta_{max} = 90^{\circ}\text{C}$ Change if necessary
No		
Does pump run after switching on manual switch?	Yes	Switch-on difference too high? (5–8 K) Check
No		Temperature display plausible? Temperature sensor may be defective or not have a good contact
Does controller switch pump?	Yes	Pump blocked 1. Pump shaft seized up? Move shaft with screwdriver (with no voltage!) 2. Pump contaminated? Clean pump If no effect exchange pump
No		Controller defective. Send it to manufacturer.

TEMPERATURE DIFFERENCE BETWEEN COLLECTOR AND STORAGE TANK VERY HIGH

The difference between the feed and return temperatures should be about 10 K (high-flow) and 30 K (low-flow) when the pump is running. See Table 4.9.

*Table 4.9.
Fault detection – very high temperature difference between collector and storage tank*

Is solar circuit pump running?	No	Has tank reached its maximum temperature? Domestic water tank $\theta_{max} = 60^{\circ}\text{C}$ Buffer storage tank $\theta_{max} = 90^{\circ}\text{C}$ If yes behaviour is normal No Check controller setting and correct if necessary Is solar circuit pump running? No Check pump and controller (see Table 4.7).
yes		
Does taco-setter show a flow?	No	Air in system Bleed it (see Table 4.9)
Yes		
Is volumetric flow suitably high? High flow: 40 l/m ² h Low flow: 10–15 l/m ² h	No	Increase volumetric flow
Yes		
Return temperature almost the same as feed temperature?	Yes	Heat exchanger affected by limescale, blocked or too small? Descale, flush or recalculate/exchange heat exchanger Or are connections confused on solar circuit heat exchanger? Connect feed to top, return to bottom

PUMP RUNNING BUT TACO-SETTER OR FLOW GAUGE SHOWS NO FLOW RATE

See Table 4.10.

*Table 4.10.
Fault detection – pump running but taco-setter or flow gauge shows no flow rate*

Are all shut-off elements open?	No	Open fittings and secure against being closed unintentionally
Yes		
Air probably in solar circuit. Bleed it (see below) Is a flow displayed?	Yes	Check pressure, refill solar liquid if necessary until operating pressure achieved
No		
Dirt trap blocked?	Yes	Clean dirt trap
No		
Gravity brake blocked?	Yes	Exchange gravity brake

The procedure for bleeding the solar circuit is as follows (because of the risk of vapour formation in times of high solar radiation this should be done if possible in the early morning or late afternoon):

1. Open all vents.
2. Increase system pressure with the help of a filling pump.
3. Operate solar circuit pump with brief pulsating movements at maximum capacity.
4. If necessary undo screw on recirculating pump, let air out and close again.
5. Close all vents after successful bleeding.

STORAGE TANK COOLS TOO MUCH OVERNIGHT WITHOUT HOT WATER CONSUMPTION

See Table 4.11.

Table 4.11.
Fault detection – storage tank cools too much overnight without hot water consumption

Solar circuit pump running at night?	Yes	Check controller function and sensor
No		
Collector temperature higher than outside temperature at night?	Yes	Check return-flow preventers in feed and return lines for proper function Sensor defective?
No		
Thermal insulation of tank sufficient? (Min. 100 mm flexible foam, 70 mm rigid foam)	No	Reinforce thermal insulation
Yes		
Does thermal insulation fit closely to tank?	No	Fit it correctly
Yes		
Are all connections thermally insulated?	No	Insulate connections
Circulation pump running too long?	Yes	Change timer setting and supplement with thermostat
No		
Switch off circulation pump and close shut-off valve for a night. Are tank losses lower?	Yes	Clean return-flow preventer, or exchange it
No		
Gravity circulation in circulation line is too strong. Install stronger return-flow preventer or electrical two-way valve after circulation pump.		
Two-way valve open during pump operation, otherwise closed. Connect pump and two-way valve in parallel electrically. Start circulation again.		

4.5 Information sources for specific countries

4.5.1 USA

- The Florida Solar Energy Center has an on-line tutorial on installation of solar water heaters: <http://www.fsec.ucf.edu/solar/install/dhwinstl/dhwinstl.htm>
- The US Federal Energy Management Program has an extensive introduction page on the technical details and installation of solar water heaters: http://www.eere.energy.gov/femp/prodtech/sw_water.html
- The Solar Energy Industries Association (SEIA) provides lists of solar equipment manufacturers and dealers on <http://www.seia.org>
- The American Society of Sanitary Engineering lists and sells relevant publications: <http://www.asse-plumbing.org/Standards.htm>
- The US Solar Rating and Certification Corporation has a certification programme of solar products, with a directory of certified products: <http://www.solar-rating.org/>

4.5.2 Australia

- Australian Standard AS 3500.4 provides installation details. Available at Standards Australia: <http://www.standards.com.au>
- The Ithaca College of technical and further education (TAFE) in Queensland has produced a solar energy course for installers (<http://www.tafe.net>).
- The Sustainable Energy Industry Association SEIA has an accreditation programme for installers of solar water heaters: <http://www.seia.com.au/Accreditation/BCSEAccreditation/Appendices/Units/BCSE402.htm>

- The Sustainable Energy Authority of Victoria (<http://www.seav.vic.gov.au>) has a solar rebate programme, and has an installers' accreditation programme in cooperation with the Master Plumbers' and Mechanical Services Association of Australia: the GreenPlumbers (solar hot water): <http://www.greenplumbers.com.au>
- Many manufacturers in Australia supply instructions on installation of their products. On <http://www.seav.vic.gov.au> a list can be found of manufacturers in the Victorian rebate programme.

4.5.3 Canada

- The Canadian Solar Industries Association offers various fact sheets on solar energy on <http://www.cansia.ca/factsheets.htm>

5 Large-scale systems

5.1 The fundamentals of designing the system size

5.1.1 Possible application areas

Large solar energy systems for water heating can be used in a multitude of buildings which have either a corresponding domestic hot water (DHW) usage, a whole year's heating requirement, or both. For example:

- hospitals
- hairdressers
- old people's homes
- fitness centres
- holiday homes
- breweries
- camping sites
- laundries
- student lodgings
- dairies
- flats
- butchers
- schools
- bakers
- barracks
- large kitchens
- office buildings
- public houses
- sports complexes
- hotels
- indoor swimming pools
- showers in open-air swimming pools
- floor heating in stables
- agriculture (cattle troughs)
- car washing facilities
- lorry washing systems.

5.1.2 Initial data required for planning the solar system

Because of the varying provision of power and energy from the sun, knowledge of the consumption quantities, the consumption profile and the desired hot water temperature is required in the dimensioning of a solar energy system. These data then feed into the dimensioning task.

The values for hot water consumption given in the literature have been found to be too high in practice: their use often leads to over-dimensioning in the planning of solar energy systems. The consumption values are frequently old, and have been calculated with the objective of providing security of supplies. Determination of the required data for the consumption profile should, if possible, be carried out by long-term measurements of the hot water consumption. If this is not possible, or is too time-consuming, then the following method can be used for acquiring the consumption data and using them for calculations in simulation programs.

5.1.2.1 CONSUMPTION PROFILE AND QUANTITY

Data must be collected to differing extents according to the various potential users (see Table 5.1). For example, Figure 5.1 shows a typical questionnaire used to obtain the required data for hot water consumption.

Table 5.1.
Examples of the data required for
calculating solar thermal systems

	Daily	Weekly	Annual	Occupational profile seasonal	Strongly variable daily requirement for HW	Operating times of secondary HW circulation	Other users in times of low water consumption
Multi-family residences	X	X	X			X	
Administration buildings	X	X				X	X
Hotels, restaurants	X	X	X	X	X	X	X
Schools, sports halls	X	X	X	X	X	X	X
Sports complexes	X	X	X	X	X	X	X
Commerce, industry	X	X		X	X	X	X
Open-air swimming pools, indoor pool showers	X			X	X	X	X
Open-air swimming pools, indoor pool			X				X
Camping sites	X	X	X	X	X	X	X

The consumption profile data thus obtained are used, for example, in simulation programs to calculate the system yield and behaviour. For this purpose the data are inserted as a table into the simulation program. Alternatively the different simulation programs offer consumption profiles for different buildings and user groups.

In order to permit planning where there is no possibility of measuring the water consumption, or in the event of uncertainties, it is possible to access standard published DHW consumption data of buildings. The following rule-of-thumb values have been determined for multi-family residences in many countries:

20–30 l (5.3–7.9 gallons) (at 60°C; 140°F) per day per person (which is roughly equivalent to 30–40 l (7.9–10.6 gallons) per person per day at 45°C (113°F)).

Moreover, the occupation of the flats (one dwelling unit = average 3½ persons) must be examined in more detail if possible. In one example a consumption of 40 l (10.6 gallons) per day per person and average occupation of 3 people was assumed. The actual consumption however, instead of the estimated 120 l (31.7 gallons) per day per flat, was in fact only 45 l (11.9 gallons) per day per flat when measured. Obviously this led to far too large a solar water heater.

5.1.2.2 REQUIRED HOT WATER TEMPERATURE

Of great significance for the future energy yield of the solar system is the target domestic hot water temperature of the application. The lowest temperature level likely to be required is 25°C (77°F) for heating the water in cattle troughs. In one/two-family homes (and also some production applications) 45°C (113°F) is sufficient. However, in many countries drinking water regulations require higher temperatures. Larger buildings usually require a temperature of 60°C (140°F) at the storage outlet. Wherever it is reasonable and safe within regulations, the domestic water heating should be restricted to the lowest possible temperature level in order to save energy.

The heat yield of the solar collector and the whole system significantly increases with a reduction in the required temperature in the collector circuit. A reduction in the water temperature generated by the sun causes a distinct increase in the energy yield per m² of collector per annum in the entire system.

5.1.3 System planning and design

At the beginning of the planning phase, rough figures on the dimensions of the most important system components – that is, the collector field and heat stores – are required for the preliminary planning and cost estimate. For dimensioning purposes there are different target sizes. The systems are designed either for a particular solar fraction using

1. Description (Indicate one)

- One family home Multifamily residence
 Refectory Student lodging Old-people's home
 Hotel Restaurant Camping site
 Nursery Sports hall School
 Other (Add description).....

2. Hot water consumption profile

State peak consumption*: litres/hour at temperature °C
 or persons/hour**

*Assume DHW is mixed down to 38°C at appliance ** valid for showers

% of daily total	Mon	Tue	Wed	Thur	Fri	Sat	Sun	Example
Between.....o'clock to..... o'clock								20%
Between.....o'clock to..... o'clock								40%
Between.....o'clock to..... o'clock								25%
Between.....o'clock to..... o'clock								15%
Total daily consumption in litres (= 100%)								1000 l

If each month is the same, write 100% = normal consumption. Otherwise indicate % days in month absent i.e. holidays

	Jan	Feb	Mar	Apr	May	Jun	Jul	Aug	Sep	Oct	Nov	Dec
Consumption in %												

Secondary domestic hot water circulation (indicate one): Yes No

**Running times: From o'clock to o'clock and from o'clock to o'clock
 and from o'clock to o'clock and from o'clock to o'clock**

Total existing hot water consumption: State if calculated or measured: l/annum

3. Special factors

Base consumption (e.g. caretaker's flat or other) persons

Total no. of showers: Total no. of shower cubicles:.....

Max. water flow per shower: l/h Max. water flow per cubicle: l/h

Type of shower (select as many as apply):
 Coin-operated:
 Timer controlled:
 Hand operated:

Hot-fill dishwashers/washing machines: Consumption: litres/day

Hotel

Overnight rooms:
 Single rooms: with showers: and washbasins:..... and baths:
 Double rooms: with showers: and washbasins:..... and baths:
 bed rooms: with showers: and washbasins:..... and baths:

Restaurant

Capacity: persons Breakfasts:...../week Lunches:...../week
 Evening meals:/week toilets with in total hot water washbasins

Figure 5.1.
 Questionnaire template to establish hot
 water consumption

existing structural conditions (for example the size of the roof, or the size desired by the customer), or for the highest possible energy yield per square metre of collector field.

For example, the owner of a one-family home may prefer to procure a solar system with a high solar fraction so that in the summer he or she can enjoy solar-heated water with the heating boiler turned off. The administrator of a multi-family residence, who would rather keep the operating costs low, asks the designer for a low solar heat price and hence low costs per square metre. Another investor, with a restricted budget, might prefer to achieve high primary energy substitution. As preheating systems achieve higher system utilization in this case, two preheating systems in two of his houses fulfil this requirement better than one solar system with a high solar fraction on one of the houses.

During client discussions, solar systems with high system utilization and the resulting high kWh yields per square metre of collector field are often stated to be the aspired objective. On the other hand, solar energy systems with high solar fractions are unjustifiably described as over-dimensioned. Both design variants are equally good if the prescribed objective (the brief) is achieved by the planning. A deviation from the expected yields that is due to incorrect consumer figures or a later change in the hot water requirement can also not be blamed on the solar system. What is decisive in the assessment of the function or performance of a solar thermal system is comparison of the actual yields with the results of simulation calculations on the basis of the actual hot water consumption.

5.1.3.1 DESIGN OBJECTIVE: HIGH PRIMARY ENERGY SUBSTITUTION

In order to achieve the greatest possible saving of conventional fuels in the project under consideration (that is, high primary energy substitution), the degree of solar coverage in the whole system must be selected to be as high as possible. Such a design is frequently sought in the case of smaller solar systems for one- and two-family homes, or in solar systems for space heating. In temperate climates, for a desired solar fraction for domestic water heating above 60%, the conventional heating can be put out of operation in the summer, which can contribute greatly to the satisfaction of the operator and to avoiding stand-still heat losses in the heating boilers. In larger solar systems, a degree of solar coverage of 50% should be targeted to achieve the design objective.

In tropical climates a solar coverage of 75–100% can be chosen.

5.1.3.2 DESIGN OBJECTIVE: LOW SOLAR HEAT PRICE

Decisive for the efficiency of the solar system is the highest possible system utilization, which leads to a high (specific) kWh yield per square metre per annum. As already described, high system utilizations are achieved with low solar fractions. These systems are also described as *preheating systems*. As this type of system usually achieves only preheating of the domestic water, even in the summer, the conventional heating system remains in operation for the full year. In temperate climates the degree of solar coverage for this design objective is between 10% and 45%; for further considerations it will be assumed to be 25%.

In tropical climates this is a less logical option unless the load is irregularly distributed over the year (for example, the holiday season for a hotel). In such cases, custom calculations need to be made.

5.1.3.3 DESIGN WITH THE HELP OF AN APPROXIMATION FORMULA

Starting point values are given in Table 5.2 for dimensioning the collector field and storage tank sizes. The following factors are used for this:

- a hot water temperature of 60°C (140°F)
- continuous domestic warm water draw-off

Table 5.2. Approximation formula for dimensioning collector fields and storage tanks for two types of climate

	Temperate climates (1000 kWh/m ² a, pronounced seasons)		Tropical climates (2200 kWh/m ² a, evenly spread over the months)
	Solar fraction 25%	Solar fraction 50%	Solar fraction 80%
Collector surface area	0.5 m ² per 50 l HW consumption (60°C) per day	1.25 m ² per 50 l HW consumption (60°C) per day	0.6 m ² per 50 l HW consumption (60°C) per day
Storage tank size	30–50 l tank volume per m ² of collector surface	50–70 l tank volume per m ² of collector surface	40–60 l tank volume per m ² of collector surface

- location with average solar radiation (approximately 1000 kWh/m²)
- south alignment of the collector field and a setting angle of 40°.

The values apply to flat collectors with good performance ($\eta_0 = 0.8$, $k_{\text{eff}} < 3.5 \text{ W/m}^2\text{K}$). System-related data must then be determined on the basis of building-specific simulations. Further simulation calculations are then required to convert to different temperature levels. The store volumes should be dimensioned fairly generously within the scope of the economic options and the space available.

Detailed building-related design should take place with the aid of recognized simulation programs (see Chapter 10).

5.2 Systems

5.2.1 Systems with domestic water store(s)

The simplest systems for solar energy systems with up to 30 m² (323 ft²) of collector field are one or two-store systems with domestic water stores and the option of thermal disinfection. The design of the stores corresponds with those in a one or two-family home. As an alternative to immersed heat exchangers providing auxiliary heating, it is possible to use an external store-charging unit (see Figure 5.2). This auxiliary heating method also permits thermal disinfection of the whole domestic water storage system. It has the following advantages and disadvantages compared with systems with buffer storage tanks:

ADVANTAGES

- simple system design
- best utilization of low collector temperatures
- fewer system components
- low costs if materials are sensibly selected
- no need for discharge regulator or heat exchangers.

DISADVANTAGES

- lower heat yields because of thermal disinfection
- under certain conditions domestic water stores may involve higher costs than buffer storage systems.

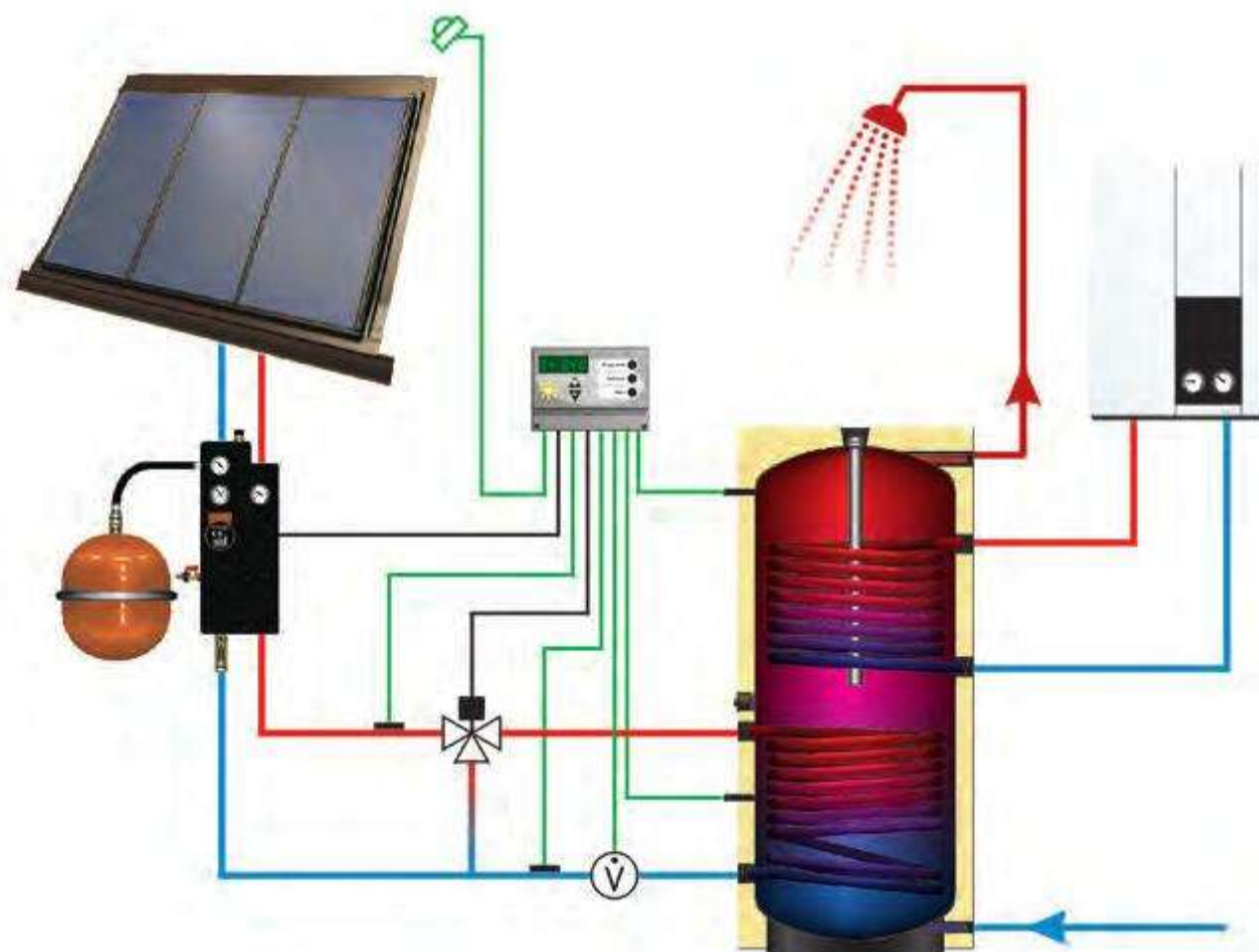

Figure 5.2.
Solar energy system with domestic water tank and the possibility of thermal disinfection

Thermal disinfection brings the whole storage system to a high temperature level. In order to minimise the solar yield loss, this should be done in the late afternoon just before a large amount of warm water is drawn off. This ensures the lowest possible storage temperatures in the evening and on the following day, which permits the

system to switch on at the earliest possible time next morning. With this system size, both immersed and external designs of heat exchanger can be used.

As the domestic water is heated by the solar system via an internal heat exchanger, a further heat exchanger can be dispensed with, compared with a system with intermediate buffer storage tanks. Thus there are lower temperature losses (temperature difference in the second heat exchanger). In the lower part of the domestic water store, the cold water temperature orientates itself to that of the domestic water supply. In this way the solar energy system can make its contribution even at low temperature levels, and thus achieve high yields.

The need for such thermal disinfection measures is obviously strongly dependent on local drinking water regulations. As thermal disinfection brings about extra energy consumption, it should be avoided when regulations allow.

5.2.2 Systems with thermal buffer stores

An increase in the temperature level in the whole domestic water storage tank automatically leads to higher energy losses in the system considered. With large domestic water stores that serve as solar energy storage systems the losses are greater than in conventional systems for hot water heating with correspondingly smaller stores. Moreover, heating of the energy store leads to a reduction in the collector circuit utilization because of the heat losses associated with the higher temperatures. The energy yield may decrease to an extent of 15% with boundary conditions that are otherwise the same.

Common to the systems described in this section is the fact that the heat gained in the collector circuit is first stored in a buffer thermal store, and is led to the domestic water store only when required. In order to obtain a high system yield, similar to those for systems with more direct energy storage, the system variants described in the following sections are used.

The use of external heat exchangers and – with the exception of stratified stores (and their internal charging) – the type of charging is also common to the systems.

When a minimum solar radiation is reached, the collector circuit pump first starts and heats up the collector circuit. If a useful temperature then exists at the entry to the collector circuit heat exchanger, the buffer circuit charging pump is switched on, and the buffer tanks are charged by means of a switching system, for example a three-way valve or a stratified-charging device in the buffer tank.

5.2.2.1 BUFFER STORAGE SYSTEMS USING THE STORAGE CHARGING PRINCIPLE

If the temperature in the hotter buffer storage zone (the right-hand buffer store in Figure 5.3) reaches a useful temperature level for heating the domestic water in the standby store, then the buffer circuit charging pump and the DHW store-charging pump are engaged. Ideally, the DHW store should be divided into a standby zone for auxiliary heating and a (lower) zone for charging by the solar system.

The upper standby zone is held continuously at the temperature level required for safe supply by the conventional auxiliary heating. Taking account of regulations, the whole domestic water storage area can be thermally disinfected (not shown in the figure). In this way top-up heating of the domestic water and thermal disinfection are carried out exclusively in the DHW store by conventional heating. In comparison with the different concepts for auxiliary heating of the domestic water to the required withdrawal temperatures, this has proved to be the most expedient with respect to the maximum utilization of the solar system.

ADVANTAGES

- Discharging of the buffer tank is possible independently of the current water consumption.
- High system utilization is achieved for the whole system with auxiliary heating only in the domestic water tank (the solar zone is not heated via the auxiliary heater, and is always at the lowest possible temperature level).
- The discharge heat exchanger can be kept relatively small and inexpensive.

DISADVANTAGES

- The DHW store requires a solar zone in the lower area, or the temperature of the

auxiliary heating must be reduced to allow charging by the solar system even at lower temperature levels.

- The discharge of the buffer storage tank must be controlled so as to keep temperatures as low as possible in the bottom zone of the colder buffer tank.

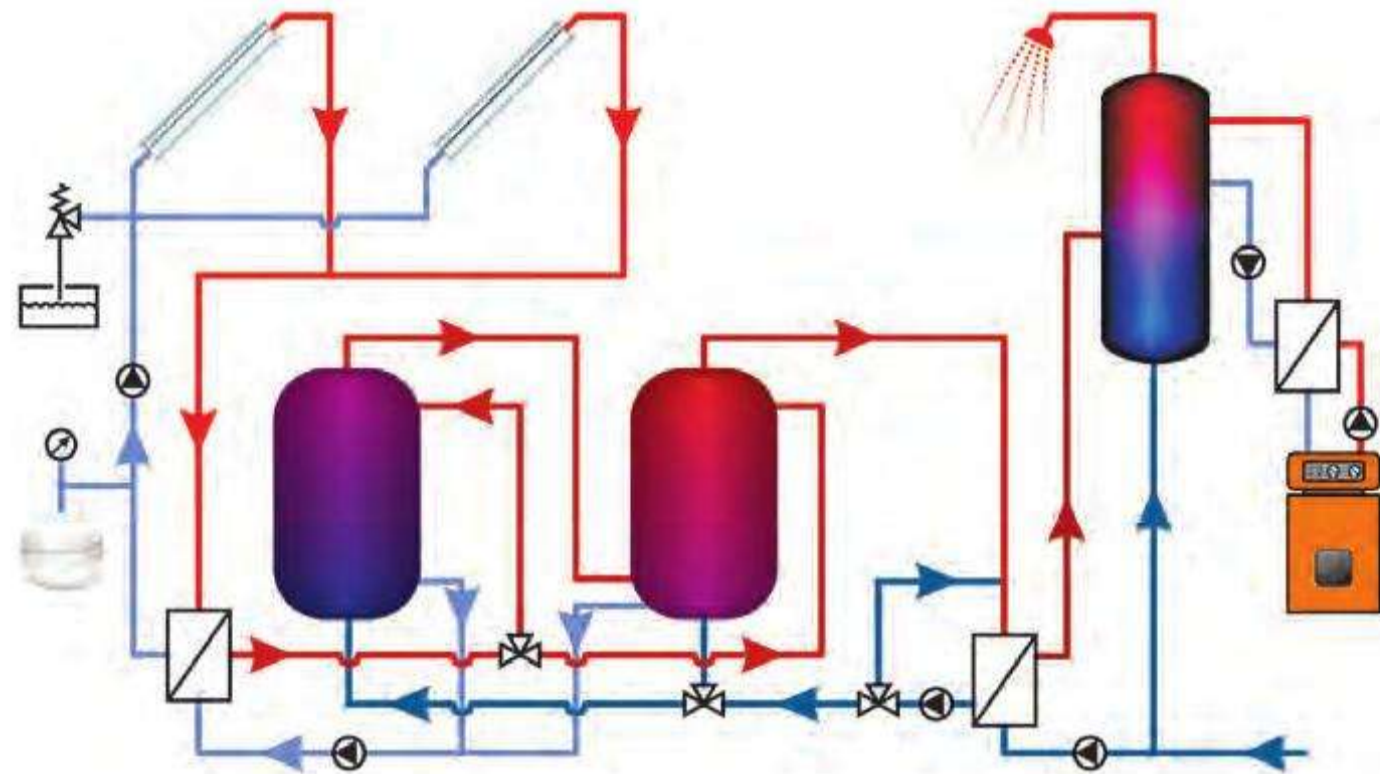

Figure 5.3.
Buffer storage system using the storage charging principle; top-up heating in the standby tank

5.2.2.2 BUFFER STORAGE SYSTEMS USING THE ONCE-THROUGH-FLOW PRINCIPLE

With this type of system (Figure 5.4) the buffer thermal store is discharged using the once-through-flow principle. When domestic water is withdrawn, and if at the same time a useful temperature level exists in the hotter buffer, this is then discharged via a circuit pump. The solar heat is then transferred to the domestic water. By controlling the volumetric flow in the discharge circuit, the buffer water can thus be cooled to, for example, 5 K above the cold domestic water entry temperature. The precondition for this, however, is very accurate matching of the volumetric flow in the buffer tank discharge circuit to the momentary withdrawal volume, which requires precise and rapid control systems.

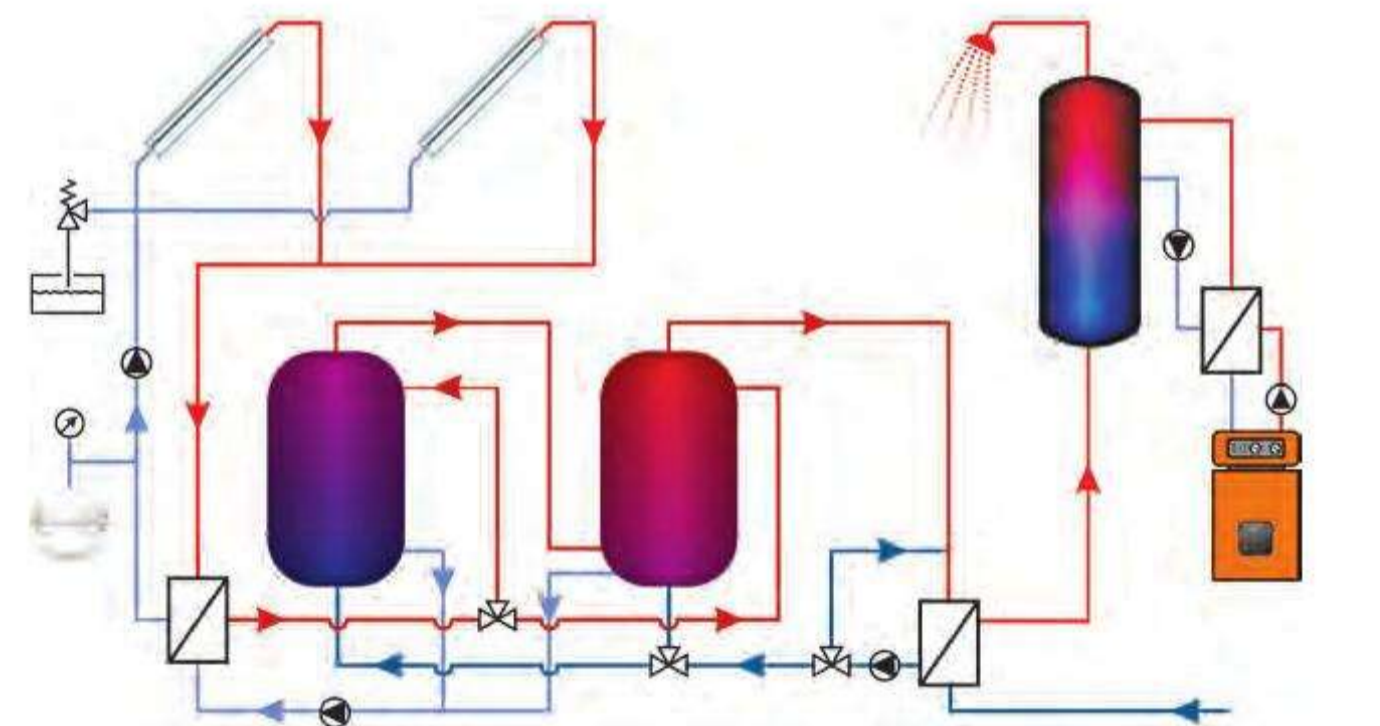

Figure 5.4.
Buffer storage system using the once-through-flow principle

Cooling of the buffer tank water is possible for both small and large withdrawal rates, and the colder buffer storage zone thus takes on the lowest possible temperatures. The solar yield is increased because of the heat transfer from the solar circuit at this low temperature level.

ADVANTAGES

- Existing domestic water tanks can continue to be operated unchanged after the installation of the solar system. Even pure once-through-flow systems can be supplemented by a solar system.
- The solar system can be linked very easily into the existing domestic water network through the installation of the discharge circuit heat exchanger.
- A higher solar yield can be achieved through the cold return to the buffer tank if the discharge controller operates perfectly.

DISADVANTAGES:

- Control of the discharge must operate very accurately; in practice this does not usually happen.
- If the withdrawal rates vary considerably and the buffer tank volume is very high, the once-through-flow system becomes sluggish and cannot supply sufficient heat from the buffer.
- The discharge circuit heat exchanger must be designed for medium or maximum withdrawal peaks, and is thus large and expensive.
- Heat exchangers cause pressure losses, which lead to pressure variations in the domestic water supply with changing withdrawal rates, which can cause unpleasant temperature variations with mixer taps.

5.2.3 Integration of circulation systems

See Figure 5.5. In order to use solar heat to cover the heat losses of a circulation line, the following general conditions should be observed:

Again, drinking water regulations greatly influence the temperature regime at which circulation systems are and should be operated. In general, temperatures of $>55^{\circ}\text{C}$ ($>131^{\circ}\text{F}$) are to be maintained. This temperature level is led back into the DHW store at a given position. Depending on the running time of the secondary circulation, a temperature increase may occur in the colder zone of a store. In addition, this circulation leads to a mixing process that also results in a lower solar yield.

Heating up of the (lower) solar zone of the store by the circulation circuit should be avoided as far as possible. The temperature level, which is significantly higher than the cold water temperature, would otherwise lead to a strong reduction in the collector circuit utilization.

For preheating systems (or systems with low solar fractions) in connection with secondary circulation and a return of $>55^{\circ}\text{C}$ ($>131^{\circ}\text{F}$), the linking of a circulation circuit into the solar system makes little sense. In a solar system with a low solar fraction, a temperature level $>55^{\circ}\text{C}$ ($>131^{\circ}\text{F}$) is achieved on only a few days in the summer, which makes coverage of the circulation losses at this temperature level practically unnecessary.

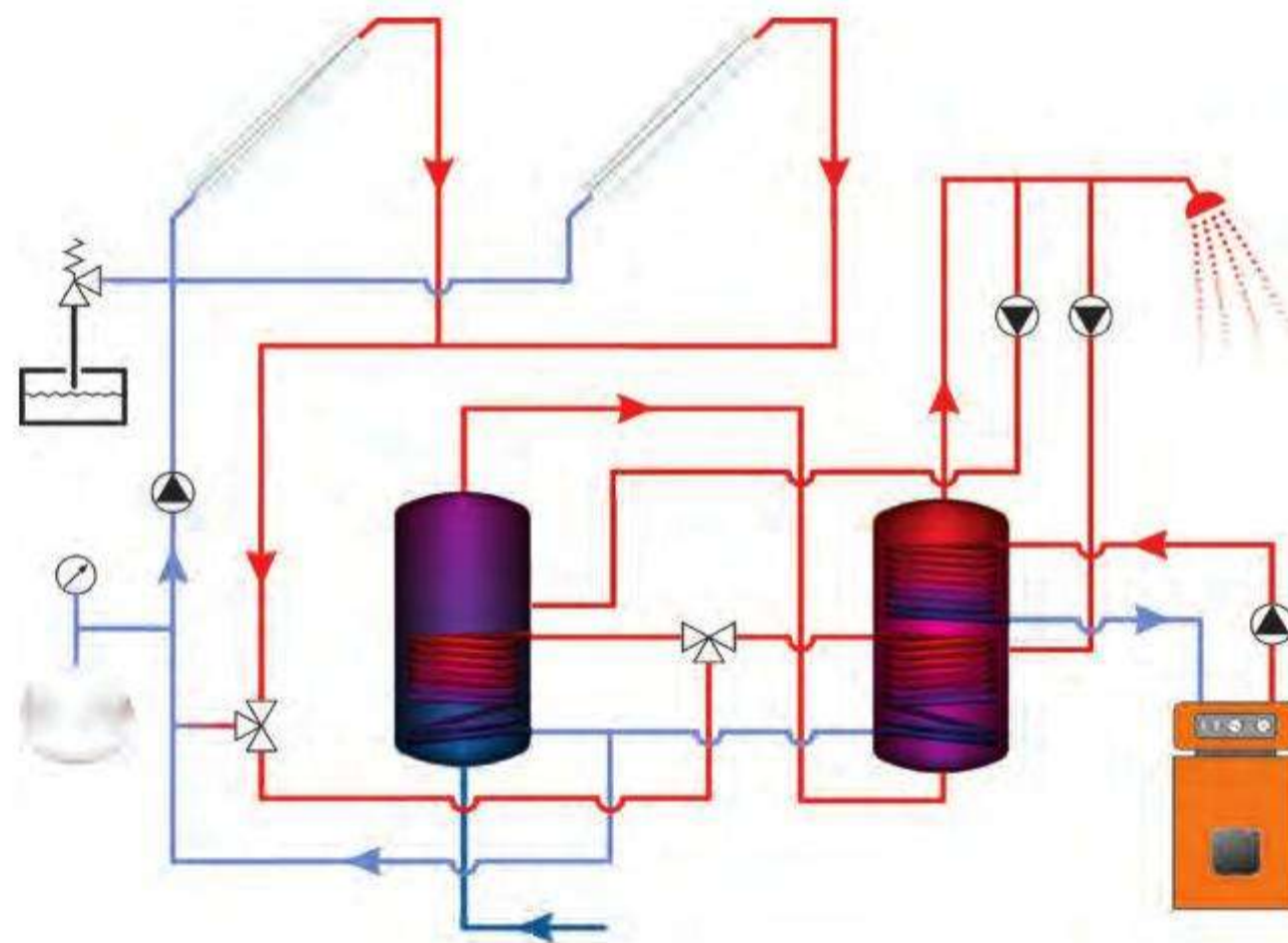

Figure 5.5.
Integration of the circulation circuit,
according to temperature, into either the
middle of the height of the left-hand
preheater tank or the right-hand standby
tank

5.3 Control of the systems

Basically, in solar systems with buffer stores two systems have to be controlled and regulated:

- the collector circuit/storage charging circuit
- the store discharge circuit.

For simplification purposes, instead of differentiating between regulation and control in the following, the term 'control' will be used.

5.3.1 Collector circuit/storage charging circuit

5.3.1.1 BASIC FUNCTION

See Figure 5.6. If there is a useful temperature difference between the collector field and the solar store, the collector circuit pump and possibly the store-charging pump are switched on, and the store is charged. If store charging is no longer possible owing to a decrease of the temperature difference, the controller switches off the pumps, and unwanted discharging of the solar store via the collector field is thus prevented. Almost all control concepts are based on the principle of temperature difference measurement and on corresponding programs for controlling the different systems.

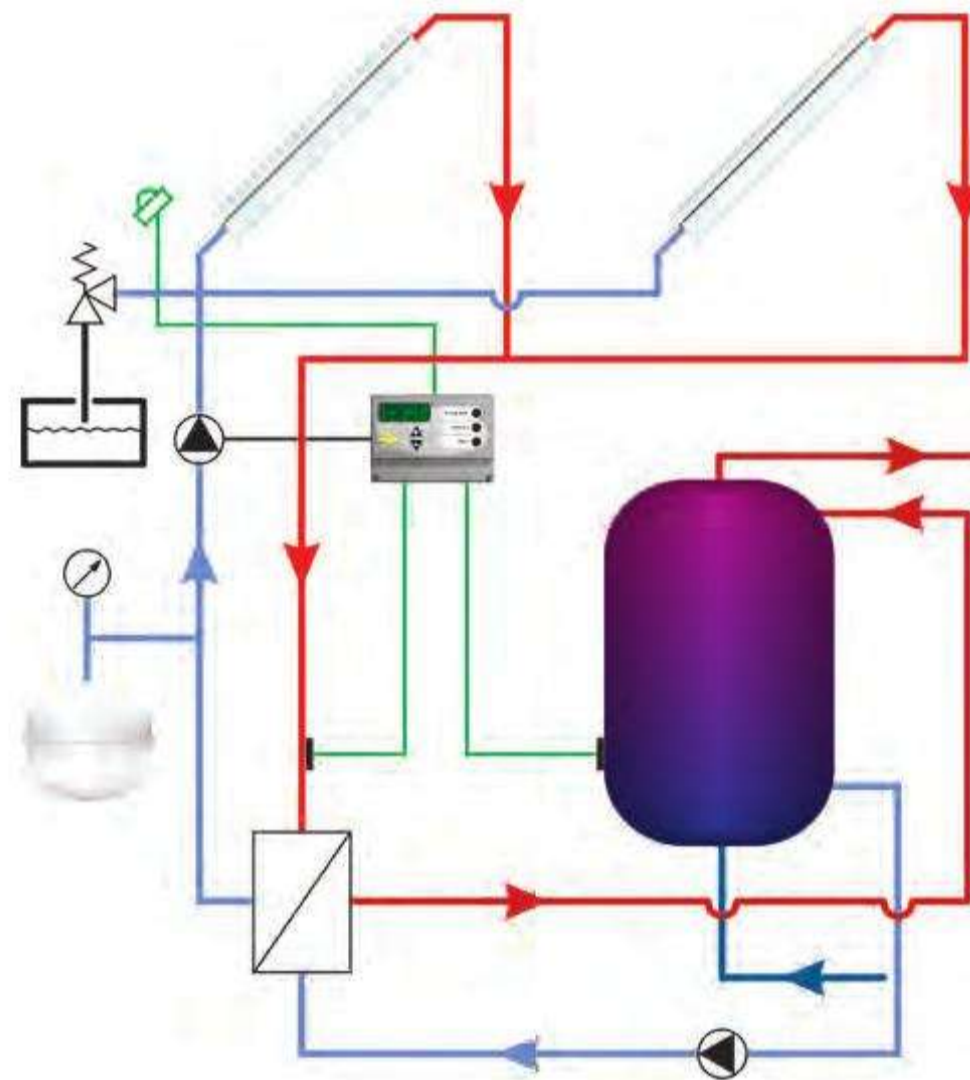

Figure 5.6.
Control of storage tank charging

The heat exchangers used in the collector circuit also influence the switching of the pumps. A small heat exchanger in the store with a reducing temperature difference between the heat transfer medium and the store can only supply an ever-smaller heat quantity to the storage water. In spite of higher temperatures in the collector, the controller must switch off the collector circuit pump in this case to avoid inefficient circulation around the collector circuit. It is therefore necessary to adapt the switch-off temperature difference to the heat exchanger performance.

5.3.1.2 CONTROL STRATEGY

Most systems and control concepts found on the market today follow the strategy of charging the solar store when an adjustable temperature difference between the collector field (or feed temperature on external heat exchanger) and the store (temperature in the lower zone) is reached. Thus, in systems with DHW storage, charging from the collector circuit starts for example as early as from a temperature of 13°C (55.4°F) in the collector (8°C (46.4°F) cold water entry plus 5 K temperature difference). During charging, this temperature level increases until the maximum storage temperature (60–95°C; 140–203°F) is reached.

The collectors, circuits and heat transfer medium have a given heat capacity. The longer the lines in the collector circuit and the greater the pipe diameter, then the greater the heat capacity in the collector circuit. The system inertia therefore increases. In systems of the size under consideration it is usual to first allow the collector circuit to 'run up to heat' via a bypass circuit (this avoids cooling of the store). The bypass circuit is not used in small solar systems with short line paths because of the lower heat capacities in the collector circuit.

5.3.1.3 BYPASS CIRCUIT WITH IMMERSED HEAT EXCHANGER AND THREE-WAY VALVE

Apart from the collector circuit pump, the collector circuit controller also manages a three-way valve (Figure 5.7). Until a useful temperature is reached at the line just before the inlet to the store, the collector circuit is switched to bypass operation and is led past the store heat exchanger. This switching system is used only in connection with immersed heat exchangers.

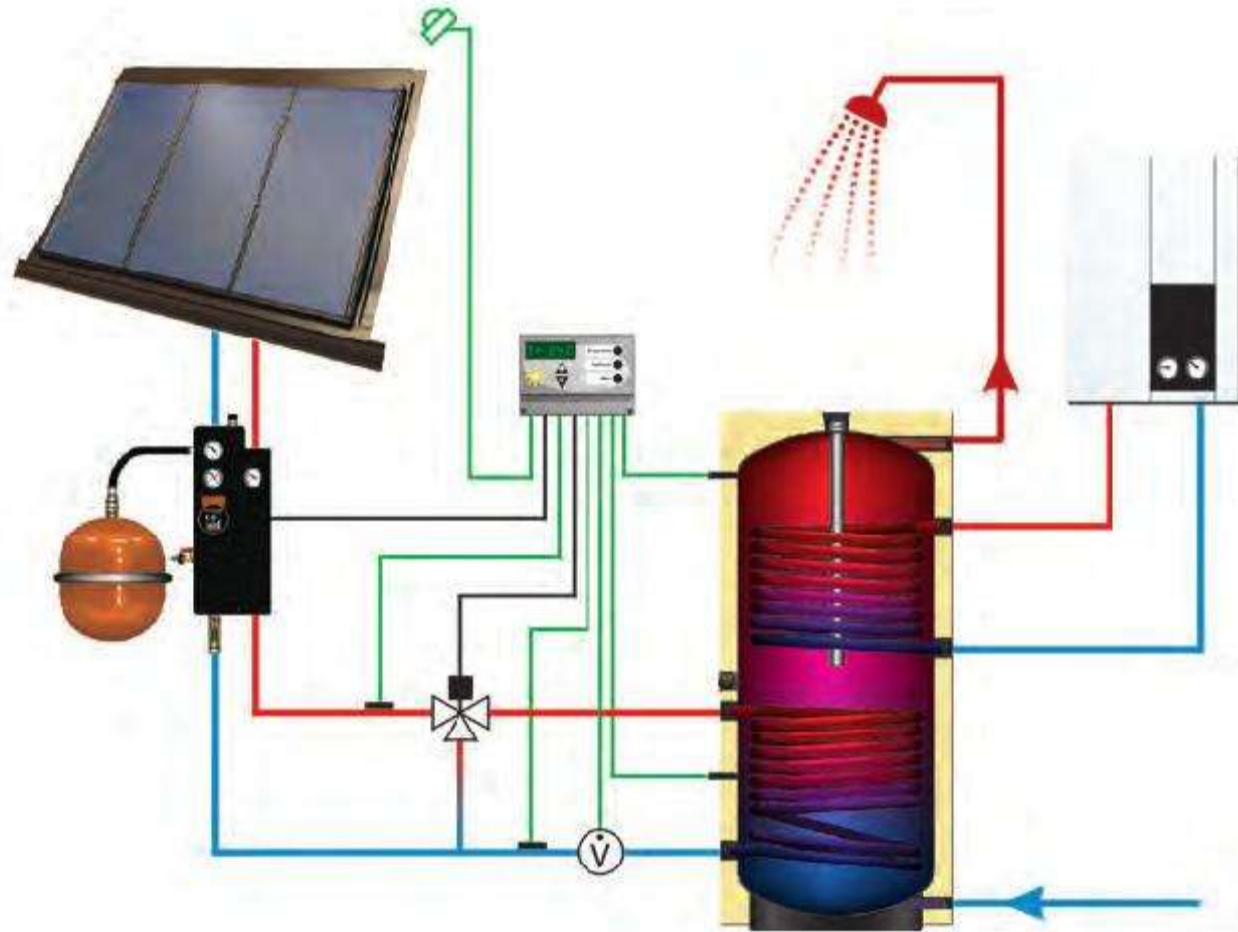

Figure 5.7.
Bypass circuit with three-way valve

5.3.1.4 BYPASS CIRCUIT WITH EXTERNAL HEAT EXCHANGER AND TWO PUMPS

Apart from the collector circuit pump, the collector circuit controller can also manage the storage circuit charging pump (Figure 5.8). Until a useful temperature is reached at the line shortly before the inlet to the external heat exchanger, only the collector circuit pump is operating. If the useful temperature is reached, the storage circuit charging pump starts to operate.

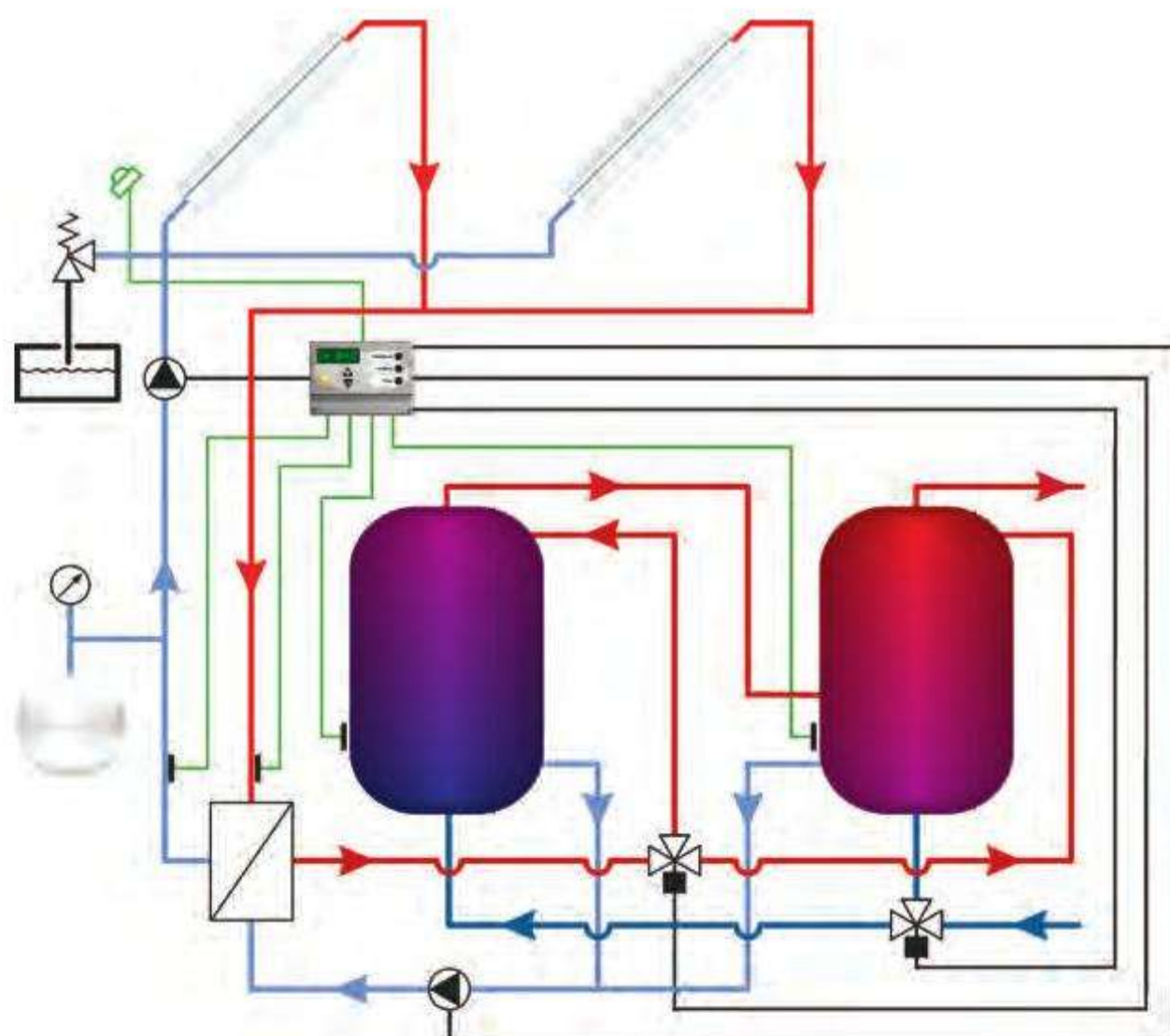

Figure 5.8.
Bypass circuit with separate control of collector and buffer tank circuit pumps

This variant is examined in more detail below, in view of the widespread use of external heat exchangers

CONTROL OF THE COLLECTOR CIRCUIT BY MEANS OF RADIATION AND TEMPERATURE SENSORS

A radiation sensor can be attached to the collector field and connected to the collector circuit controller. With sufficient solar radiation, the collector circuit pump is started up. To start the pump it is advisable to compare the measured radiation value with the store temperature. During system operation, the controller continuously gathers information on the activity of the collector circuit pump with corresponding radiation values as well as the store temperature. For instance, at a store temperature of 50°C (122°F), the collector circuit pump does not start up until the solar radiation exceeds 500 W/m²; at a store temperature of 10°C (50°F), the pump switches on as early as at 150 W/m²; and so on. This avoids having the collector circuit pump start up at a solar radiation level that is too low for further charging of the store. Moreover, the controller is matched to the changed gain and loss variables in the collector circuit through the continuous gathering of the new temperature and radiation values.

If the heat transfer medium in the collector circuit at the temperature sensor in front of the heat exchanger inlet reaches a useful temperature difference of $\Delta\theta = 2\text{--}5$ K above the store temperature, the charging pump is started. If $\Delta\theta$ falls below 1–3 K the buffer circuit charging pump is stopped. Moreover, if the intensity of the sun's radiation measured at the radiation sensor decreases below a threshold, the collector circuit pump is also switched off. The system is not restarted until the intensity of the sun's radiation increases again.

If the collector circuit pump is started at a fixed value, for example 130 W/m², this can lead to extremely long operating times of the pump without yields. For example, the solar radiation can be just slightly above this value for the whole day but the collector will still not reach a useful temperature level. Also, when the store is already very hot, a renewed starting of the collector circuit pump in the bypass can be pointless (for example, if the sun comes out after an afternoon shower, the collector temperature will not exceed the store temperature even by late evening).

Shading of the radiation sensor must be avoided. For example, the solar cell can be put out of action by bird droppings: this type of fault should be considered in the case of defects.

CONTROL OF THE COLLECTOR CIRCUIT BY MEANS OF TEMPERATURE SENSORS

The collector circuit pump can be switched on if the temperature at a temperature sensor in the collector is 5–7 K above the temperature at the lower store sensor. If a temperature of 2–5 K above the store temperature is measured at the sensor in front of the heat exchanger inlet, the store-charging pump is also started. If the temperature difference falls below 2–4 K the pumps are switched off one after the other.

5.3.1.5 STORAGE TANK CHARGING AT DIFFERENT TEMPERATURE LEVELS

See Figure 5.9. To achieve useful temperatures in the stores rapidly, they should be divided into different temperature levels. This can be done by series connection on the discharge side, in which the store is charged alternatively into the cold or hot storage area. With the use of valves and pumps to control the different tanks the temperature levels should be limited to two, independently of the system size, as with the increasing use of pumps and valves the susceptibility to faults also increases greatly, without the solar yield being significantly increased.

Charging of the two levels can alternatively take place by means of a three-way valve or a second charging pump. After a useful temperature for charging a storage level has been measured at the temperature sensor in the collector circuit in front of the heat exchanger inlet, the three-way valve is opened at the corresponding charging level. With the use of two storage tank charging pumps instead of the three-way valve the corresponding storage tank charging pump is started to charge the usable level. A priority storage area (charging level) is usually defined in the controllers for charging. This charging level is then loaded as a priority, and only if no further temperature increase is possible is the second charging level used.

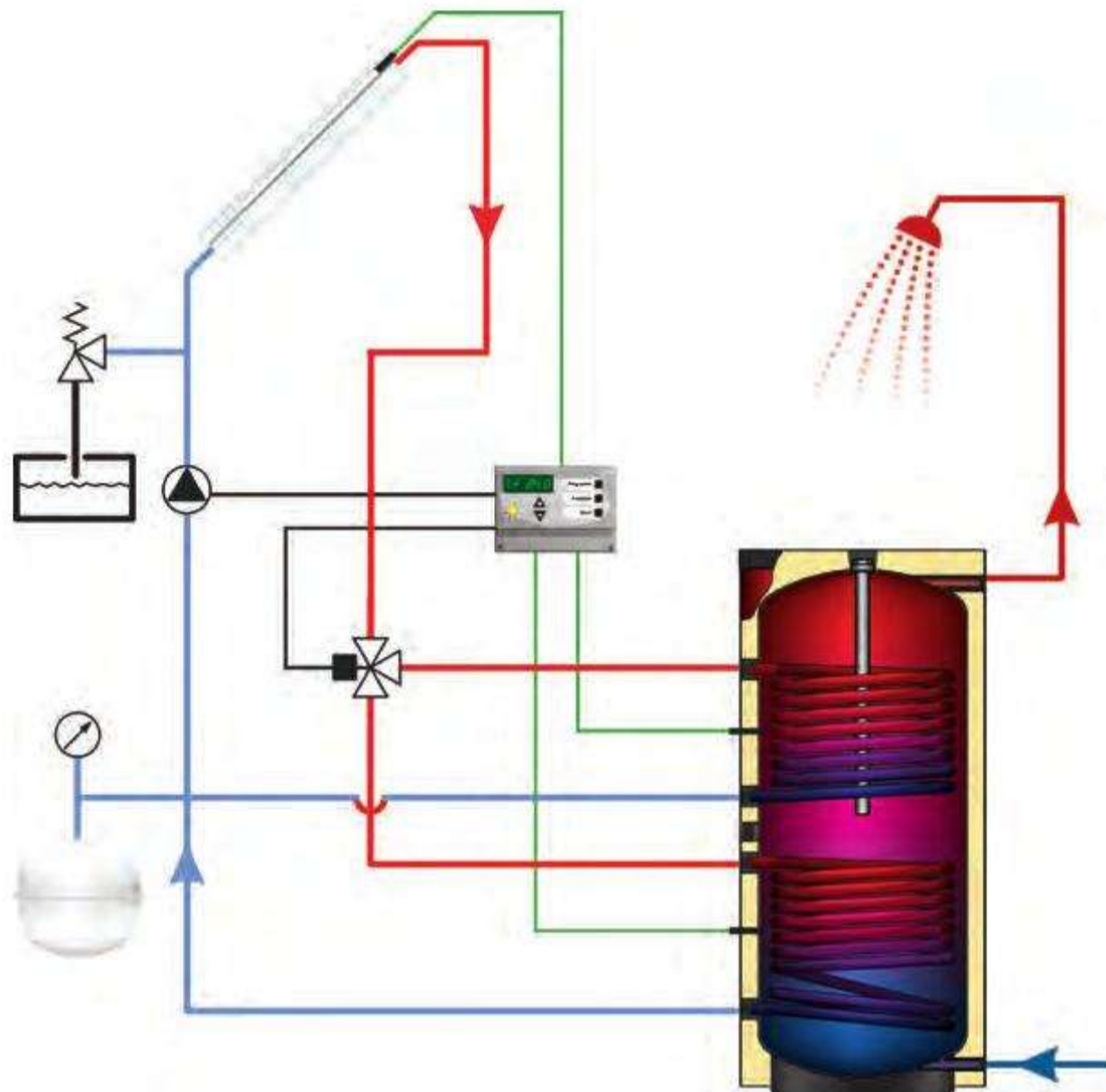

Figure 5.9.
Charging a storage tank with different temperature levels (immersed heat exchanger)

5.3.1.6 STORAGE TANK LOADING IN THE CASE OF TANKS WITH STRATIFIED CHARGING EQUIPMENT

See Figure 5.10. When using layer charging equipment it is also possible to charge several stores in a series-connected system. The heated water always exits through the charging equipment in the warmer store at the charging level corresponding to its temperature. In this way, in the case of high temperature levels the warmer store is charged in the upper area. If the charging temperature level falls, the heated water exits the charging equipment at ever-lower levels. If the temperature level of the loading circuit in the warmer tank can no longer be used, the water is fed into the corresponding temperature level of the second (colder) tank via the alternative route of the lowest layer.

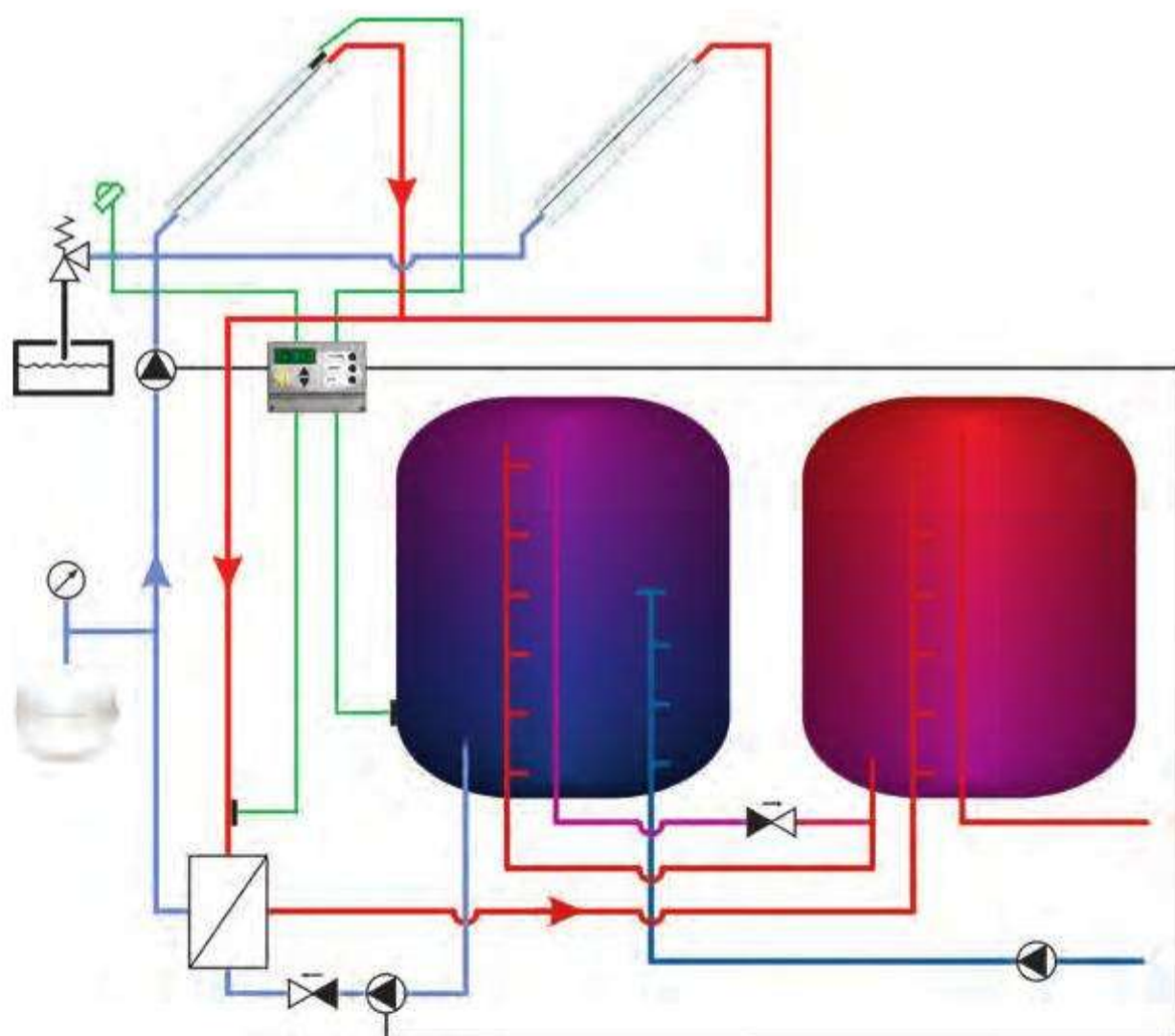

Figure 5.10.
Storage tank loading for tanks using stratified charging equipment

This storage loading system requires a controller that has been especially matched. This only measures the temperature in the coldest tank; charging of the different levels takes place automatically through the layer charging equipment without the use of further valves or pumps (see also Chapter 2, section 2.3.2.1).

5.3.2 Buffer tank circuit discharging

According to the discharging strategy, correspondingly adapted control concepts are used according to either the storage charging principle or the once-through-flow principle.

To avoid possible limescale build-up in the discharge heat exchanger of the buffer storage system and, moreover, to establish a maximum temperature for the design of the heat exchanger, the temperature in the inlet of the discharge heat exchanger is limited, for example, to 55°C (131°F) (but taking into account drinking water regulations). This takes place through a mixing process by a thermostatic mixing valve in the inlet or a mixer in the return line from the heat exchanger. The thermostatic mixing valve is set to the desired maximum inlet temperature to the heat exchanger. The three-way valve or the three-way mixer in the return line is controlled by means of a fixed-value controller or, for smaller systems, also by a thermostat head with remote sensor. The accuracy of the controller thereby depends on the running time of the valve/mixer and the speed of the signal processing in the fixed-value controller. For systems with discharge controllers for controlling the once-through-flow principle, which react very quickly, the feed restriction is therefore often dispensed with, as its control speed is too low in comparison with the discharge regulation.

5.3.2.1 STORAGE TANK CHARGING PRINCIPLE

The discharge controller compares the temperatures in the (warm) buffer and in the bottom area of the domestic water store. If the temperature in the buffer is 2–5 K higher, the pumps are started to discharge the buffer. If the temperature difference falls below 1–2 K both pumps switch off.

During charging, the temperature in the domestic water store increases and hence also in the buffer discharge return. To avoid too severe an increase in the return flow temperatures in the buffer discharge, the temperature in the lower zone of the domestic water store is often limited. To discharge the buffer store, temperature difference controllers should therefore be installed to limit the maximum temperature via the measuring sensor (= lower storage sensor). The maximum temperature can be set, for example, to 30°C (86°F).

If the domestic water storage cools down as a result of more water being drawn off, then charging continues if a useful temperature level exists in the buffer tank.

To avoid undesirable heating up of the colder buffer tank during the charging operation, an additional three-way valve can be installed in the return line of the discharge circuit. If a higher temperature is then measured at the temperature sensor than in the colder buffer, then the three-way valve switches over the flow to the warmer buffer tank.

The three-way valve is not necessary for buffers with stratified charging equipment, as the buffer discharge return line is led into the respectively matched temperature level through the stratified charging equipment.

5.3.2.2 ONCE-THROUGH-FLOW PRINCIPLE

The objective of this principle is the best possible cooling of the buffer water during discharging or the maximum temperature increase in the domestic water. To meet both objectives the volumetric flow of the discharge circuit must be matched to the (variable) volumetric flow of the domestic water circuit. This is done by cycling (or speed controlling) the discharge pump.

The discharge controller measures the temperature difference between the top of the (warmest) buffer tank and the cold water. If the buffer is 2–5 K warmer than the cold water entry, the pump for the buffer discharge circuit is started up at, for example, 10% of its nominal flow rate. In this way the inertia of the discharge circuit is first overcome, and a useful temperature is achieved in the discharger heat exchanger for immediate use at the hot water taps. The controller monitors the flow in the domestic water circuit. If a flow is measured here the buffer discharge pump is started

and the volumetric flow from it is regulated according to the criterion 'coldest possible return flow'. For this purpose, with the discharge pump running, the temperature difference is measured between the entry temperature of the cold water and the exit temperature of the return flow.

If the buffer circuit discharge pump is cycled by the controller (or is speed-regulated), a selectable temperature difference is set up between the cold water entry and the return flow of the buffer discharge circuit of, for example, 5 K. The buffer circuit can thus be discharged down to the temperature of the cold water entry plus 5 K.

For this control variant it is necessary to use precise and fast-reaction sensors. Moreover, the controller must possess high scanning rates when acquiring measured values. The sensors must be installed according to the manufacturer's instructions using immersion sleeves. To avoid pressure losses or possible error sources the measurement of the flow should take place if possible in the domestic water circuit by means of temperature comparisons instead of flow monitors or the like. Additional manufacturer's instructions concerning the positioning of sensors must be taken into account with respect to the yields.

Note: In practice these systems do not usually operate without faults. They should therefore only be used in discharge units that have been preconfigured by the manufacturer. In any case great care is necessary when installing them.

5.4 Heat exchangers

5.4.1 Design types

5.4.1.1 IMMERSED HEAT EXCHANGERS

Stores with immersed heat exchangers are most often installed in solar systems for one- and two-family homes. These internal heat exchangers are wound with (Cu-) plain, finned tube or plain steel or stainless steel tube. For their design, and for a logarithmic mean temperature difference of 10 K (see also the following pages), the following approximate formulae are valid:

- plain tube heat exchangers: 0.2 m² area per m² of collector field
- finned tube heat exchangers: 0.3–0.4 m² area per m² of collector field.

In the case of plain tube heat exchangers the energy is transmitted via the surface of the tube. As the temperatures of the entire surface of the tube and that of the medium inside the tube are very close, the same temperature difference between the medium in the tube and the surrounding medium is available over the whole surface. On the other hand the average temperature difference between the surface of a finned tube heat exchanger and the surrounding medium is lower than that for plain tube heat exchangers because of the lower temperature at the ends of the fins (see Figure 5.11).

One square metre of surface on the plain tube heat exchanger can therefore transmit more energy than one square metre of the surface of a finned tube heat exchanger. The surface area of a finned tube heat exchanger is, however, significantly increased by the fins, so that a finned tube heat exchanger – in spite of a lower transmission performance per square metre – is more compact than a plain tube heat exchanger with the same performance.

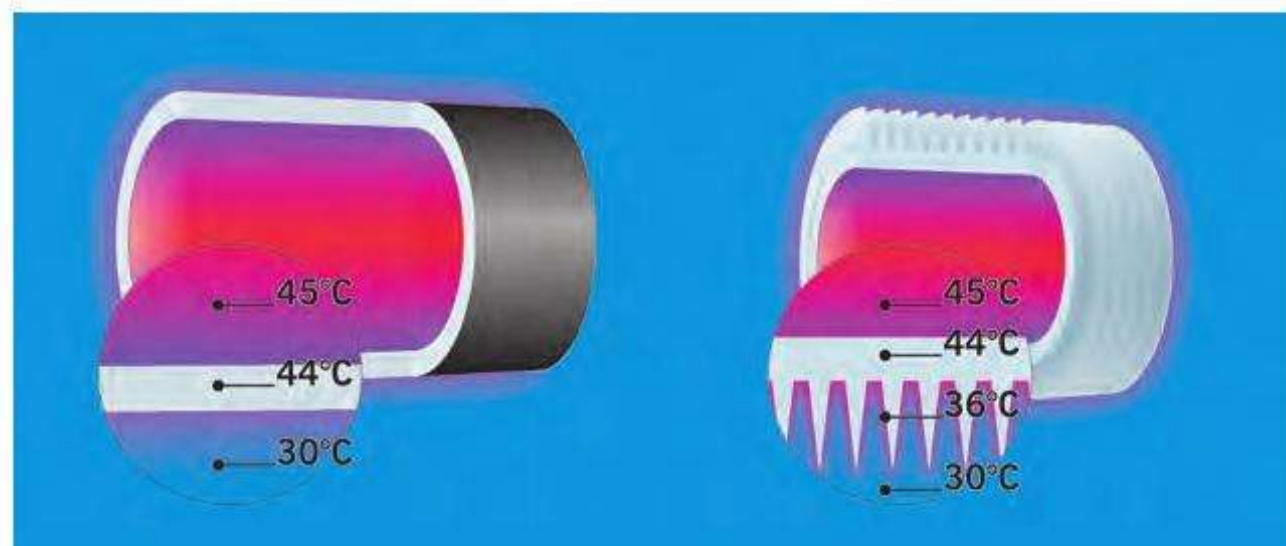

Figure 5.11.
Temperature progressions in plain and
finned tube heat exchangers

In large solar energy systems, immersed heat exchangers take up a significant volume in order to increase the efficiency of the collector field, especially if the logarithmic mean temperature difference is to be limited to 5 K. If several stores are used, then one heat exchanger with the full transmission performance is required for each store, which leads to higher costs. In larger solar systems, therefore, external heat exchangers are usually installed so that all stores can be charged with just one heat exchanger. Even if a further pump is required for these systems, this variant is preferable.

5.4.1.2 EXTERNAL HEAT EXCHANGERS

For external heat exchangers we similarly differentiate between tubular and flat plate heat exchangers. Tubular heat exchangers made from stainless steel are mainly used in solar energy systems for heating the water in swimming pools.

In the case of flat plate heat exchangers (Figure 5.12) we can differentiate between screwed and soldered models. In the *soldered* version, pressed stainless steel plates are soldered together. In the *screwed* version, the stainless steel plates are fitted with seals and then screwed together with threaded rods. Soldered plate heat exchangers can normally be obtained up to particular performance sizes, and in the smaller performance area are cheaper than the screwed variants. For the solar energy systems considered in this chapter, soldered plate heat exchangers using the counter-current principle are preferred.



Figure 5.12
Cross-section through a plate heat
exchanger (SWEF, Hildesheim)

To avoid corrosion damage, soldered plate heat exchangers should not be used for heating swimming pool water.

Heat exchangers differ from one another on the basis of the plate geometry, the once-through-flow and the construction. A heat exchanger can therefore not be replaced by another model from the same or another manufacturer without a recalculation.

5.4.1.3 COMPARISON OF IMMERSED AND EXTERNAL HEAT EXCHANGERS

Advantages of immersed heat exchangers:

- Simple system construction with few components.
- Without domestic water being drawn off, mixing takes place only by convection in the individual tanks.

Disadvantages of immersed heat exchangers:

- With several stores, a heat exchanger dimensioned for the full performance of the collector field is required for each tank: this leads to high costs.
- Highly stratified charging systems can be used only with special heat exchangers.

Advantages of external heat exchangers:

- With several stores, costs are lower than for immersed heat exchangers.
- Stratified charging systems are simpler to implement.

Disadvantages of external heat exchangers:

- Additional components; complicated installation on site.
- In the event of an unfavourable arrangement of the inflow on the charging side, disturbance to the temperature stratified effect in the tanks.

5.4.2 Collector circuit heat exchangers

See Figure 5.13. Collector circuit heat exchangers are designed for a maximum performance of 600 W/m² of collector field.

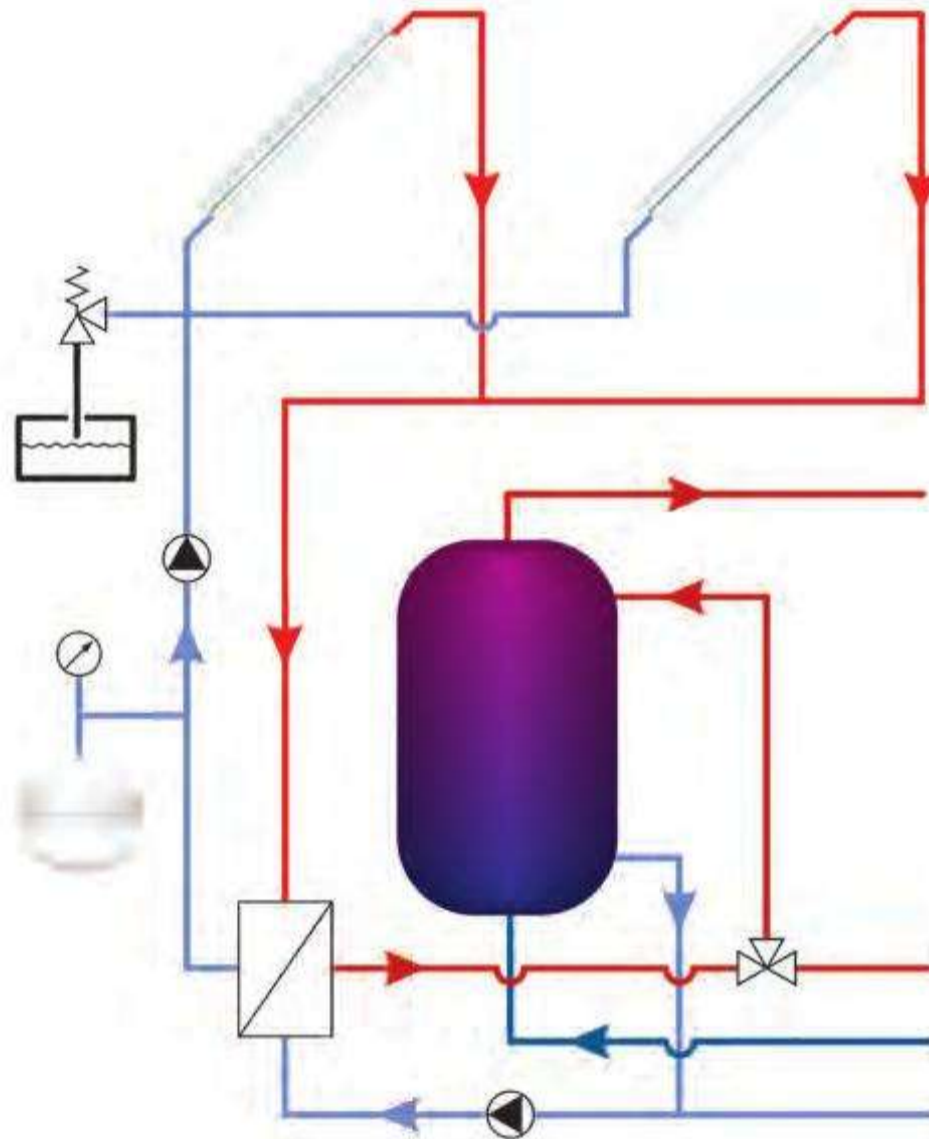

Figure 5.13.
External collector circuit heat exchanger

The figure 600 W/m² is a guide value that arises from averaged values for the irradiated power of the sun and the efficiency of the collectors. The assumptions for this are an irradiance of 1000 W/m² of collector field and an assumed efficiency of 0.6.

Through the dynamics of the irradiated power and the operating conditions in the collector circuit, this value is rarely achieved. On the other hand, the value of 600 W/m² of collector field can indeed be exceeded briefly. For these cases the temporary under-dimensioning of the heat exchanger and the resulting increase of the temperature level in the collector circuit are acceptable, in order to keep the heat exchanger costs within a sensible range.

The temperature spread of the collector circuit (inlet/outlet of heat exchanger) is obtained from the following formula:

$$\Delta\theta = \frac{\dot{Q}_{\text{col}}}{\dot{m}c_{G,W}}$$

where \dot{Q}_{col} is the collector performance (W), \dot{m} is the mass flow (kg/h), and $c_{G,W}$ is the specific heat capacity of the solar fluid (Wh/kgK).

Collector systems have different temperatures at different times of the day depending upon the solar radiation and the charging condition of the store. For dimensioning the heat exchanger, the temperature at the start of storage charging is used. At the outlet of the heat exchanger (collector circuit return line) a temperature

of 5–10 K above the cold water temperature is used for systems with buffer stores; for systems with domestic water stores a temperature of 0–5 K above the cold water temperature is used. These temperature differences occur because a buffer circuit that is connected between the collector circuit and the domestic water system is at a higher temperature than the cold water temperature because of the necessary temperature difference for heat transfer. The collector circuit has a higher temperature than the tank temperature owing to the necessary additional heat transfer.

For central Europe, with an average cold water temperature of 12°C (53.6°F), this would amount to temperatures of 22°C (71.6°F) and 17°C (62.6°F) respectively. In the example in section 5.4.3, the temperature pairs are used for systems with buffer storage tanks. In warm climates the cold water temperature may be higher – up to 25°C (77°F) or more.

The inlet temperature into the heat exchanger is derived by adding the outlet temperature in the primary solar circuit and the temperature spread arising (see formula above). On the secondary side of the heat exchanger the temperature spread $\theta_A - \theta_E$ is equal to the temperature spread $\theta_A - \theta_E$ on the primary side, where θ_A = exit temperature and θ_E = entry temperature. At the entry to the secondary circuit (buffer charging circuit) the temperature is 17°C (62.6°F). The volumetric flow on the secondary side is obtained from the calculation of the heat exchanger.

Note: Because of the different designs of heat exchangers every manufacturer achieves different values for flat plate heat exchangers with the same exchange surfaces. Therefore the heat exchangers used must be calculated with a program from the respective supplier.

5.4.3 Buffer tank discharge circuit heat exchangers

For systems that, apart from the collector circuit heat exchanger, require an additional heat exchanger to transfer the heat to the domestic water circuit, the following considerations are necessary:

- To avoid limescale build-up, a constant entry temperature should be set before the inlet to the heat exchanger by means of a thermostatically controlled three-way mixing valve (see Figure 5.14). This should be between 55°C and 60°C (131 and 140°F) or, for designs with auxiliary heating in the buffer tank, between 65°C and 70°C (149 and 158°F).
- In selecting the heat exchanger it is necessary to consider the possibility of subsequent cleaning, bearing in mind particularly the lime content of the water. Considering the better cleaning possibilities and the avoidance of a type of crevice corrosion in the heat exchanger soldering, screw-fitted heat exchangers are recommended here. These can be reactivated by (cost-intensive) dismantling and

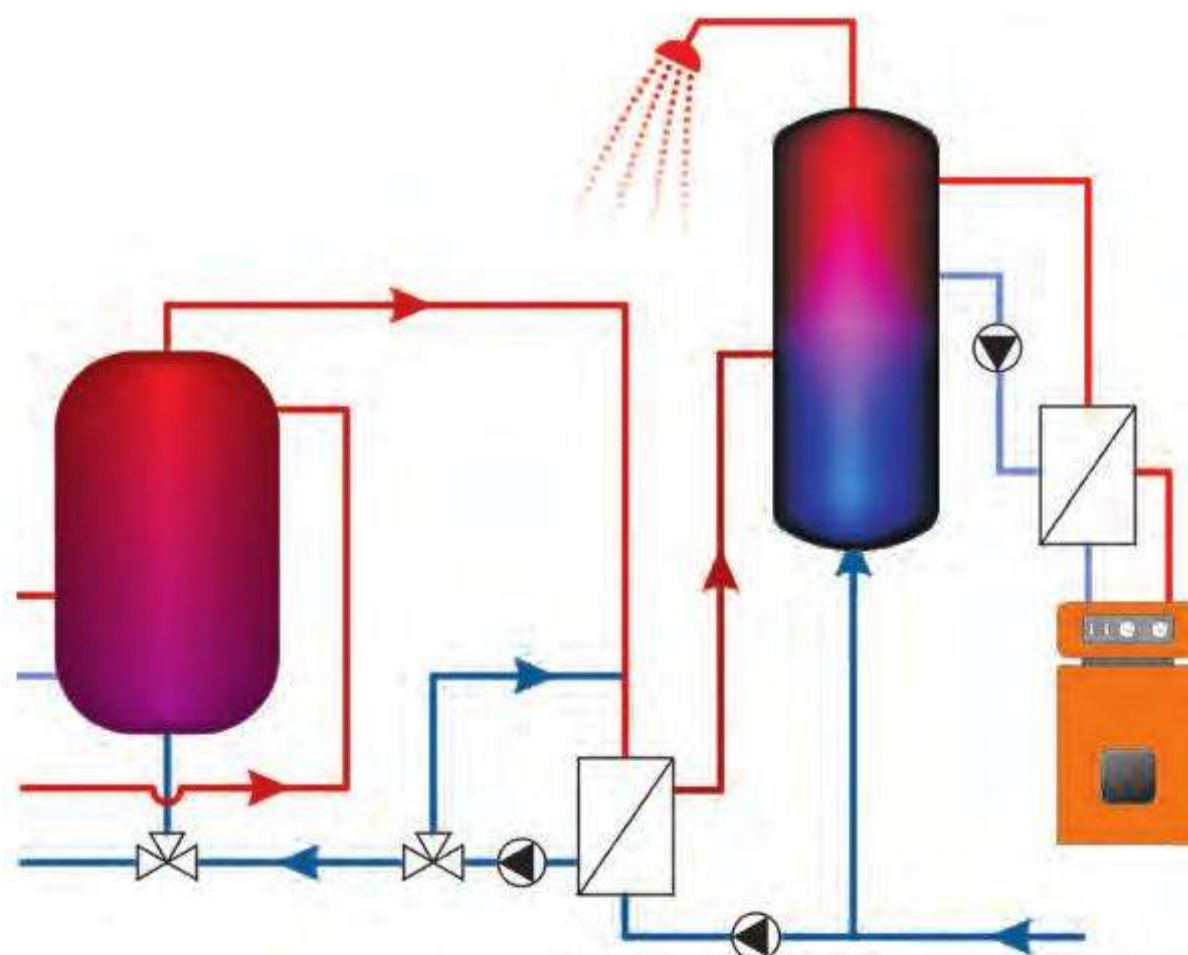

Figure 5.14.
Heat exchanger using the storage
charging principle

as otherwise the heat in the buffer is not transferred sufficiently at the peaks and the tank can only be discharged partially. If only a small part of the overall consumption is withdrawn at peak times, the heat exchanger can be designed, for example, to 50% of the calculated or measured withdrawal peak.

In practice, systems are designed to achieve an adjustable outlet temperature on the domestic water side (only for systems with high solar fraction or auxiliary heating in the buffer storage tank) or to the lowest possible return temperature in the buffer tank circuit.

The following temperature pairs are used for the design (again, using our example):

- Buffer tank circuit side
Inlet: 55°C (131°F)
Outlet: 17°C (62.6°F)
- Domestic water side
Inlet: 12°C (53.6°F)
Outlet: 45°C (113°F)

As the basis for calculating the required maximum performance, the highest withdrawal peaks must be established, for example with the help of the simultaneity model (estimation by multiplying the flow through a single consumption point by the square root of the number of consumption points). The performance is calculated from the mass flow of the withdrawal peak and the desired inlet/outlet temperatures. Calculation of the performance peak (in kW):

$$\dot{Q} = \dot{m} c_w \Delta\theta$$

with \dot{m} from the simultaneity calculation for the withdrawal peak, $c_w = 1.16 \text{ Wh/kgK}$ and $\Delta\theta = 45^\circ\text{C} - 12^\circ\text{C} = 33 \text{ K}$.

In this once-through-flow variant, it is essential to take account of the increased pressure loss (through the heat exchanger) in the domestic water system. At peak withdrawal times supply problems could otherwise occur (in the form of pressure and temperature variations).

However, not all of the heat exchangers designed for these peaks function satisfactorily in the partial load area. Very low or virtually no pressure losses in the heat exchanger calculation clearly show a heat transfer that is too low in the partial load area of the calculated operating case. The reason for this is the low k -value of the heat exchanger, caused by laminar flow in this performance range which will reduce the heat transfer rate per unit of transfer area. During design and installation the selected heat exchanger must therefore be recalculated in discussions with the manufacturer. This problem can be reduced or circumvented by designing the heat exchanger to, for example, a maximum of 50% of the peak withdrawal rate.

5.4.3.3 COMPARISON OF THE ONCE-THROUGH-FLOW PRINCIPLE AND STORAGE TANK LOADING PRINCIPLE

The greatest advantages of the once-through-flow principle are a (theoretical) very low return temperature to the buffer tank and simple integration into the existing system. The advantage of a lower return flow temperature can, however, be achieved in practice only with correct heat exchanger dimensioning and accurate installation of the control system. For solar systems with large buffer volumes and circuit dimensions, the system inertia should be considered in relation to the control of the once-through-flow principle. Considering the problems that currently still exist, the greatest care is needed when using the once-through-flow principle.

The store-charging principle can also be used where very high performances have to be transferred with inexpensive heat exchangers and without any effects on the domestic water network (no pressure variations). With a suitable controller, its function is the same as the once-through-flow principle. If the connection of store charging is implemented as shown in Figure 5.15, the system behaves in its operation like a combined storage charging/once-through-flow system. If the amount of withdrawn hot water is low, the whole domestic volumetric flow is led through the heat exchanger. If no hot water is

drawn off, then the system operates according to the storage charging principle by using the storage charging pump. If very high quantities of hot water are drawn off, cold water is led through the heat exchanger according to the volumetric flow of the charging pump. The rest flows into the store and can later be heated by solar energy.

5.5 Safety technology

5.5.1 Collector field

If the collector system is classified as steam or pressure equipment (such as the European Pressure Equipment Directive 97/23/EC, see section 12.2 and/or national regulations), strict additional requirements apply. For instance, in Germany, steam boiler regulations for a Group III steam boiler system (up to 50 l volume (13.2 gallons)) (for limits see Appendix B ‘Technical regulations’), stipulate that a larger collector field must be divided into partial fields with 50 l (13.2 gallons) in each. The individual collector fields must then be provided with closing devices, which must be protected from unintentional closing, and safety valves (Figure 5.16). The respective safety valve must, however, not be closable with respect to the collector leg. The safety valves on the field section/collector leg must be authorized for temperatures up to 225°C (437°F) and also have a common discharge to a collecting reservoir in the building. The blow-off lines must be made of copper (for corrosion resistance). Their exit cross-section and the cross-section of the safety valves must meet the steam regulation requirements; the discharge lines from the safety valves must thereby be steam-safe and discharge without danger to personnel. The dimensions for the safety valves can be taken from Table 5.3.

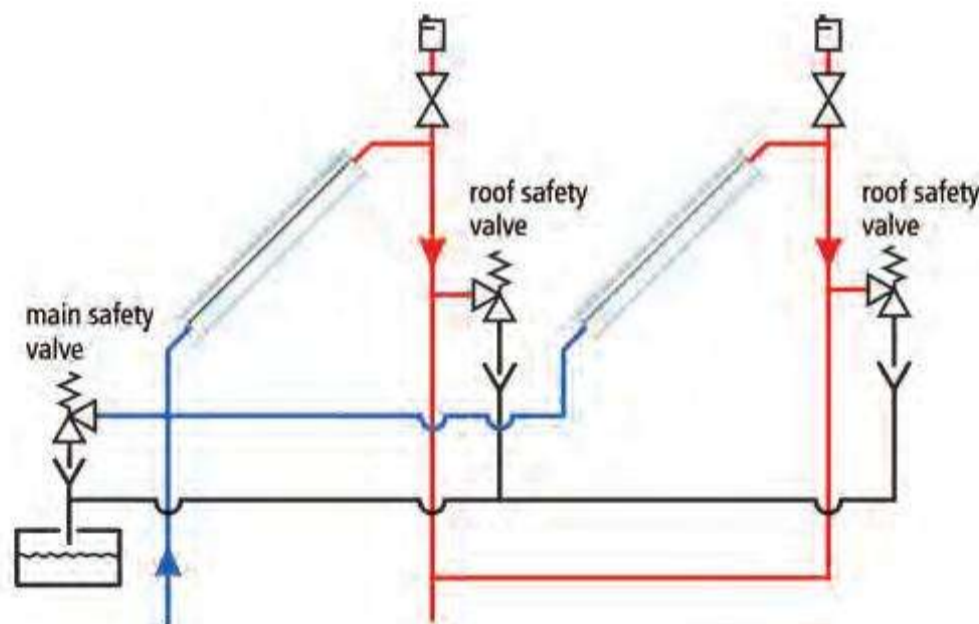

Figure 5.16. Arrangement of the safety valves when dividing the system into partial fields

Table 5.3. Safety valves (entry cross-section) for collector fields

Valve size (entry cross-section) DN	Collector surface area (m ²)
15	50
20	100
25	200
32	350
40	600

If the solar energy system is not designed as a steam boiler system, according to the new formulation of the European Pressure Equipment Directive, it is still necessary to test the ability to shut off and correspondingly secure individual parts of the collector field, in order to be able to carry out any necessary maintenance to the collectors without too much expense.

If the path from the roof to the main safety valve is long, the discharge from the safety valves in the collector field should be into individual containers close to the field to save money. These containers must be temperature- and weather-resistant; galvanized steel should not be used, in order to avoid reactions with the heat transfer medium.

5.5.1.1 EVAPORATION IN THE COLLECTOR FIELD

With the high stagnation temperatures of modern collectors, boiling of the heat transfer medium simply through pressures significantly above 10 bar (145 psi) cannot

be ruled out. As solar energy systems are normally fitted with standard components for up to PN10, the manufacturers and designers limit themselves to a maximum pressure of 6 bar (87 psi) or 10 bar (145 psi) in the collector circuit. Vapour formation is thus entirely possible in the collector field at 6 bar (87 psi). If the solar system is designed with a high degree of solar coverage, long and frequent stagnation times can be expected. In such a situation the following should be noted.

If such systems are operated at high pressure, then boiling in the collector cannot safely be avoided, but – because of the pressure – it takes place at a higher temperature. As a result the whole filled volume of the collectors is subject to a high thermal load. Conventional glycol mixtures can be subject to accelerated ageing because of this. Therefore systems in which long stagnation times are expected should be set at a maximum operating pressure of, for example, 4 bar (58 psi); or a heat transfer medium should be selected with a high thermal resistance for flat and evacuated tube collectors.

Below the temperature and pressure conditions described in the vapour pressure chart for the heat transfer medium, no vapour phase will form. A glycol/water mixture of 40/60% by volume will vaporize above a temperature of about 170°C (338°F) at a pressure of for example 8 bar (116 psi) in the collector circuit. Below this temperature, or with a higher pressure, the heat transfer medium will remain in the liquid phase.

The collectors of such systems are designed for the evaporation and resulting condensation of the heat transfer medium. This affects the whole content of the collector as well as a part of the connecting lines because of the temperature progression in the collector and the collector circuit. Evaporation may well affect the whole collector circuit (particularly with short lines, for example with roof central heating systems), depending on the collector type. This vapour volume must be taken into account when calculating the expansion vessels. It is essential to take into account the dangers from vapour escape during the installation of automatic bleeders or safety valves in the vapour formation zones. Automatic bleeders must therefore be closed or shut off. The exit openings on safety valves in the potential vapour formation zones must be fitted so that there can be no danger to personnel.

In drainback systems, the controller usually switches off the pump when the water in the store reaches the maximum allowed temperature. The collector field will then drain, and boiling of the collector fluid is thus avoided. The collectors will go into 'dry' stagnation. Although this is an elegant solution, refilling of the collector circuit while it is stagnating at very high temperatures may need special design attention.

5.5.2 Collector circuit

The (main) safety valves should be dimensioned as per Table 5.3, in which the nominal widths must correspond as a minimum with the values shown.

The safety valves must be matched to the heat performance of the collector leg and/or the collector field, and must also be able to discharge the maximum performance of the collector field in vapour form. In inherently safe systems (in which even at system stagnation the expansion vessel is capable of taking the increase in volume of the system content and the corresponding vapour volume in the collector field) discharge is also permitted in the liquid phase at the main safety valve. The main safety valve must be authorized for temperatures up to 120°C (248°F). The response pressure of the safety valve must correspond with the maximum operating excess pressure permitted for the collector. The closing pressure of the valve must be a minimum of 90% of the response pressure.

The response pressure of the main safety valve on the collector circuit should be designed so that it is significantly (1 bar (14.5 psi)) below the response pressure of the field safety valves. This ensures better monitoring of the system function (excess medium first escapes into the connection space). For systems with a static head of water of more than 10 m (32.8 ft) at the installation location of the main safety valve, it can have the same response pressure as the valves in the collector field. Owing to the higher system pressure at the installation location (field pressure plus static pressure) the main safety valve will be the first to open in the event of a pressure rise.

The blow-off line must be installed so that in the event of a vapour escape there can be no risk to personnel. The blow-off line is led into a collecting tank to catch the glycol/water mixture. The blow-off lines from the safety valves in the collector field

should also end in this collecting tank. This must be temperature-resistant and must be able to take at least the liquid volume (= collector content + connecting lines) displaced by the vapour in the collector field. If possible, a capacity to take the whole system contents is sensible for filling and repair work. For refilling the plant, a manually operated pump should also be available.

5.5.2.1 REQUIREMENTS OF THE COLLECTOR CIRCUIT

A typical flat-plate collector may reach stagnation temperatures above 200°C (392°F); evacuated tubes reach temperatures up to 280°C (536°F). The high temperatures occur during system stagnation – that is, in the event of failure or the desirable switching-off point of the pump in the collector circuit. If the system starts up again after such a switching off at high temperatures, temperatures of up to 130°C (266°F) can arise in the collector circuit.

In order to operate the system safely even at high temperatures, a maximum pressure of 6 bar (87 psi) is usually permitted in the collector circuit and for systems with high static pre-pressure 10 bar (145 psi). The operating pressure is usually 0.5–0.8 bar (7.25–11.6 psi) above the static pressure of the system to safely prevent the penetration of air. In individual design concepts, an operating pressure of 4 bar (58 psi) has been selected to avoid evaporation in the collector circuit during complete system operation. Further descriptions about system pressure can be found in section 5.5.4.

5.5.3 Buffer store circuit

Steam laws and regulations vary widely between countries. Here, an example is given for Germany. The buffer store is classified as a pressure vessel according to Section 8 of the German Pressure Vessel Regulations:

- Containers in which the pressure is applied only by liquids, whose temperature does not exceed the boiling temperature at atmospheric pressure (that is, 100°C (212°F) for water), belong to group V 'Pressure vessels with a permitted operating excess pressure p_{\max} of no more than 500 bar (7252 psi) ($p_{\max} < 500$ bar)...'. Buffer storage tanks in Group V, which are made to correspond with the specifications in the AD Codes of Practice, can be started up without the acceptance of an expert or a competent person. The test confirmation and proper marking of the container are sufficient.
- If the maximum temperatures in the buffer storage tank are >100°C (212°F) at atmospheric pressure it is classified as: Group II 'Pressure vessels with a permitted operating excess pressure p of not more than 1 bar (14.5 psi) and a permitted pressure contents product $p_{\max} \times$ content in litres of more than 200 ...'. These containers, according to Section 10, paragraph 2 of the German regulations, must be subject to repeated testing. This test must be carried out by a competent person (but not by an expert); the extent of the testing is established in Section 10.

In general it is recommended that the containers be limited to operating temperatures below 100°C (212°F) and designed according to the requirements of Group V, in order to avoid the cost of testing.

As far as the buffer stores are concerned, temperatures should be restricted to the permitted maximum temperature of the selected pressure vessel group. This can be done by setting the maximum store temperature on the solar controller, or by means of an additional safety temperature limiter (STL). This equipment is also specified in the case of indirect heating for temperatures in the heating medium >110°C (230°F). At this point it must, however, be considered that temperatures in excess of 110°C in the heating medium occur only very briefly in the collector circuit, and the standard is clearly valid for heating media with constant temperatures in the heating medium >110°C. With some manufacturers the use of STLs in connection with solar storage is required only above a specified collector surface area per litre of tank content.

If a safety temperature limiter has been triggered by briefly exceeding the response temperature, further heating of the storage is stopped, as the pump and hence the solar system are permanently switched off. In such a case the system can only be started up again manually. To avoid unnoticed stoppages, it is essential for an STL to be connected to a fault alarm signal.

As this concerns use of the standards for conventional heating systems, which cannot be sensibly applied fully to solar systems, the supplier of the components should be asked for a written comment in the case of any uncertainties.

The storage should be safeguarded by a corresponding safety valve that is suitable for the size of the store and the thermal output of the collector field. The safety valves must thereby correspond to the requirements listed in Table 5.4.

Table 5.4.
Safety valves for buffer storage tanks in accordance with DIN 4753 P1

Nominal capacity of water container (l)	Maximum heating capacity (kW)	Maximum capacity corresponding to collector field size (m ²) ^a	Connection diameter of safety valve, min.
up to 200	75	125	DN 15
200–1000	150	250	DN 20
1000–5000	250	417	DN 25
over 5000			1.25 in

^aMaximum capacity 600 W/m² of collector

5.5.4 Expansion vessels

If the buffer store is integrated into a closed system, installation of an expansion vessel is necessary. The standard calculation programs can be used for dimensioning. The following example is intended to provide an idea of the size of the expansion vessel.

EXAMPLE

The expansion vessel is to be calculated for a buffer store with a content of 8000 l (2113 gallons), a filling temperature of 10°C (50°F) and a maximum temperature of 90°C (194°F). The response pressure of the safety valve is 2.5 bar (36.3 psi), and the filling pressure in the buffer tank 0.2 bar (2.9 psi). The pressure information represents an excess pressure against atmospheric pressure. The calculation in this case results in a minimum volume of 543 l (143 gallons). According to the manufacturer's information two expansion vessels with a rated volume of 280 l (74 gallons) each are selected to reduce costs.

At the maximum temperature of 90°C (194°F) in the buffer tank, it must be ensured by means of a cooling length or an auxiliary vessel that a maximum temperature of 70°C (158°F) is not permanently exceeded at the membrane of the expansion vessel.

5.5.5 Fittings on the domestic water line

The safety valves on the domestic hot water storage tank are dimensioned as described in Table 5.4 for the buffer. The safety valve should be installed into the cold water feed, and must not be capable of being shut off with respect to the domestic water. To avoid the safety valve responding to the expansion from the heating up of the water, installation of an expansion vessel is also recommended for the domestic water tank (Figure 5.17).

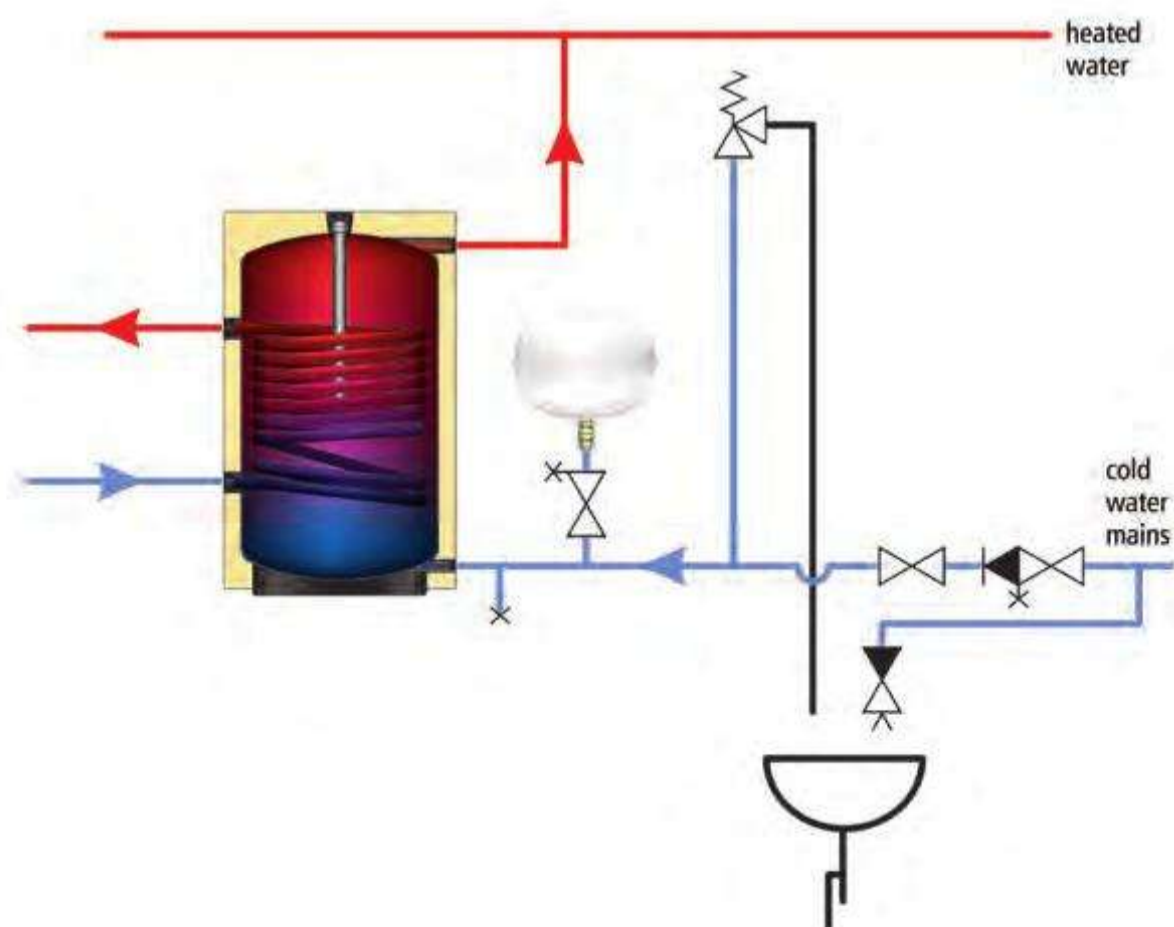

Figure 5.17.
Safety devices for domestic water heater

5.6 Economic considerations

The following considerations apply to the cost side. By determining annuities for the cost of the solar system and taking account of the energy yields of the solar system, the specific costs per kWh of solar-generated energy are calculated. These specific costs are called the *solar heat price*. If, for example, a system is planned for a multi-family home, it is possible to determine a mixed price from the proportionate costs for fossil and solar heat for calculation purposes. It is also possible in this way to make the costs for the individual dweller transparent in calculating the water heating costs, by converting these costs to the square metre of the respective dwelling unit.

5.6.1 Annuity method

In the annuity method, non-periodic and periodic payments with changing amounts are transformed into periodic constant payments over a considered period. The annuity is this periodic constant amount, and is made up of the interest and repayment portions for the repayment of the capital used. This method of calculation permits the types of payment arising in various periods to be added directly. For example, interest and repayments for the investment are transformed with the help of the annuity factor a into average payments over a considered period T .

The payments are divided into two categories according to their temporal requirements: one-off or non-periodic payments, and regular payments. The individual costs are summarized under the general terms capital-related, consumption-related and operation-related. The considered period is taken as the service life of the short-lived and/or the more capital-intensive system components, so that the residual value has to be determined for the remaining system components. For solar energy systems consideration of the system as a whole has become the norm. After the considered period expires the whole system is regarded as being written off; no residual value is set.

The following types of costs are to be considered:

- capital-related costs, such as interest and repayments as well as servicing costs
- consumption-related costs: costs for the auxiliary energy (electricity for the pump)
- operation-related costs, such as insurance costs.

5.6.1.1 GENERAL PROCEDURE

For all types of costs the annuities are separately determined and added together:

$$AN_{\text{tot}} = AN_c + AN_s + AN_o$$

where AN_{tot} is the total annuity, AN_c is the annuity for capital-related costs, AN_s is the annuity for consumption-related costs, and AN_o is the annuity for operation-related costs.

The annuity for capital-related payments is given by

$$AN_c = A_0 (1 - R)a + f_k A_0 b a_{\text{SER}} = AN_i + AN_{\text{SER}}$$

where AN_c is the annuity for capital-related payments (= €/a or \$/a or £/a); AN_i is the annuity for investment-related payments (€/a or \$/a or £/a) = $A_0(1 - R)a$; AN_{SER} is the annuity for servicing payments = $f_k A_0 b a_{\text{SER}}$; A_0 is the procurement costs for the system;

$$a = \frac{q^T (q - 1)}{q^T - 1} = a(q, T)$$

T is the period considered in a (a = years, latin: annus); q is an interest factor which = $1 + (p/100)$, p is the interest (%); f_s is a factor for establishing the service costs in %/year of investment amount without grant; $b a_{\text{SER}}$ is a price-dependent annuity factor for servicing payments = $b(T, q, r_s) \times a(q, T)$, and $b(T, q, r_s)$ is a cash value factor; r_s is the annual price change factor for servicing payments; and R is a component-specific residual value factor. The residual value is usually set to zero for solar systems.

The annuity for consumption-related payments is given by

$$AN_c = A_{c1} b a_c$$

The annuity for operation-related payments is given by

$$AN_o = A_{o1}ba_o$$

5.6.1.2 EXAMPLE CALCULATIONS ACCORDING TO THE ANNUITY METHOD

A solar energy system is considered with a price of €76,694/\$76,694/£53,686 including VAT and planning. The system supplies a solar heat yield of 55,000 kWh/a and has a surface area of approximately 100 m² (1076 ft²). Table 5.5 shows the calculation sheet for € or \$, and Table 5.6 the sheet for £.

Individual simulation programs such as T*SOL (see Chapter 11) offer the option of carrying out the economic calculations in parallel with the project-related simulation calculations. In this way the economics can be considered easily.

Table 5.5.
Calculation sheet according to VDI
2067 for solar systems (values in € or
US\$)

	System				
	$p = 6\%, T = 20 \text{ yrs}$		$p = 6\%, T = 25 \text{ yrs}$		
	No grant	30% grant	No grant	30% grant	
Investment amount, A_0	76,964	53,686	76,964	53,686	
Annuity factor, a	0.087	0.087	0.078	0.078	
Investment-related payments	6672	4671	5982	4187	
Price change factor for servicing	1.05	1.05	1.05	1.05	Price-dynamic for calculation
Servicing factor, f_s	0.005	0.005	0.005	0.005	
Payments for servicing in first year	383	383	383	383	
Price-dynamic annuity factor	1.506	1.506	1.651	1.651	
Annuity for payments for servicing, AN_{SER}	578	578	633	633	
Price change factor for auxiliary energy, r_{aux}	1.05	1.05	1.05	1.05	Price-dynamic for calculation
Payments for auxiliary energy in year 1	141	141	141	141	
Price-dynamic annuity factor	1.506	1.506	1.651	1.651	
Annuity for payments for auxiliary energy, AN_{aux}	212	212	232	232	
Price change factor for insurance, r_{ins}	1.05	1.05	1.05	1.05	5000 m ² building at €0.41/\$0.41 total supplement €20.5/\$20.5 per annum
Payments for insurance in year 1	20	20	20	20	
Price-dynamic annuity factor	1.506	1.506	1.651	1.651	
Annuity for insurance payments, AN_{ins}	31	31	34	34	
Total annuity (€/a or \$/a)	7492.93	5490.71	6881.13	5086.50	
Solar yield (kWh/a)	55,000	55,000	55,000	55,000	
Heat price (€/kWh or \$/kWh)	0.14	0.10	0.12	0.09	

5.6.2 Types of costs for solar energy systems

The following general conditions apply to the individual types of costs in solar systems.

The considered period for the annuity calculation is normally 20 years for solar systems. This figure is often seen as too conservative, as the main cost component (the collector field) can easily have a service life of 30 years. Individual considerations are thus often carried out with time spans of 25 and 30 years. Interest rates are always changing, but an interest rate of $p = 6\%$ has been used for the above calculation.

5.6.2.1 CAPITAL-RELATED COSTS

The capital-related costs are the largest proportion of solar system costs. They are made up of the investment amount, A_0 , and – as a small proportion of this – the payments for servicing and maintenance. The investment amount, A_0 , can be reduced by public subsidies.

Table 5.6.
Calculation sheet according to VDI
2067 for solar systems (values in £)

	System				
	$p = 6\%, T = 20 \text{ yrs}$		$p = 6\%, T = 25 \text{ yrs}$		
	No grant	30% grant	No grant	30% grant	
Investment amount, A_0	53,876	37,580	53,876	37,580	
Annuity factor, a	0.087	0.087	0.078	0.078	
Investment-related payments	4670	3270	4187	2931	
Price change factor for servicing	1.05	1.05	1.05	1.05	Price-dynamic for calculation
Servicing factor, f_s	0.005	0.005	0.005	0.005	
Payments for servicing in first year	268	268	268	268	
Price-dynamic annuity factor	1.506	1.506	1.651	1.651	
Annuity for payments for servicing, AN_{SER}	405	405	443	443	
Price change factor for auxiliary energy, r_{aux}	1.05	1.05	1.05	1.05	Price-dynamic for calculation
Payments for auxiliary energy in year 1	99	99	99	99	
Price-dynamic annuity factor	1.506	1.506	1.651	1.651	
Annuity for payments for auxiliary, energy AN_{aux}	148	148	162	162	
Price change factor for insurance, r_{ins}	1.05	1.05	1.05	1.05	5000 m ² building at £0.29; total supplement: £14.4 GBP per annum
Payments for insurance in year 1	14	14	14	14	
Price-dynamic annuity factor	1.506	1.506	1.651	1.651	
Annuity for insurance payments, AN_{ins}	22	22	24	24	
Total annuity (£/a)	5245	3843	4816	3561	
Solar yield (kWh/a)	55,000	55,000	55,000	55,000	
Heat price (£/a)	0,10	0.07	0.08	0.06	

The factor f_s for calculating the servicing and maintenance costs may be estimated as 0.3–0.5% of the investment cost (without subsidies). This factor is lower than for conventional heat generators, as the wear on a solar system is lower. The larger the system, the smaller the factor f_s .

This can be explained by the type and extent of maintenance work. This consists mostly of visual inspections in which the travelling time of the maintenance personnel constitutes a significant part. Moreover, the percentage of the investment costs for moving parts such as pumps, valves and expansion vessels becomes considerable as the system size increases.

5.6.2.2 CONSUMPTION-RELATED COSTS

In solar systems these cost components are restricted to the payments for auxiliary energy – in other words mainly the electricity costs for controller and pumps. Standard figures for the level of this consumption portion are in the range 2–5% of the solar yield.

5.6.2.3 OPERATION-RELATED COSTS

In conventional systems for energy generation the costs of operating personnel, boiler operatives etc. are included in this cost component. These personnel are not required for the solar system considered. Instead, the costs for insuring the solar energy system are inserted. According to the type of insurance (building insurance/solar system insurance) different costs arise, which relate to the size of the building for an extension of the building insurance, or to the investment in the solar system for the solar system insurance. In practice solar systems have not generally been insured.

5.7 Solar contracting

An economic alternative to the self-operation of a heating system is contracting. In contracting, an energy supply company, also called a *contractor*, supplies the building completely with room heating and hot water. Solar thermal systems are ideal for

incorporating into contracting arrangements, where the contractor sets up, finances and operates the conventional hot water heating system and the solar thermal system (see Figure 5.18).

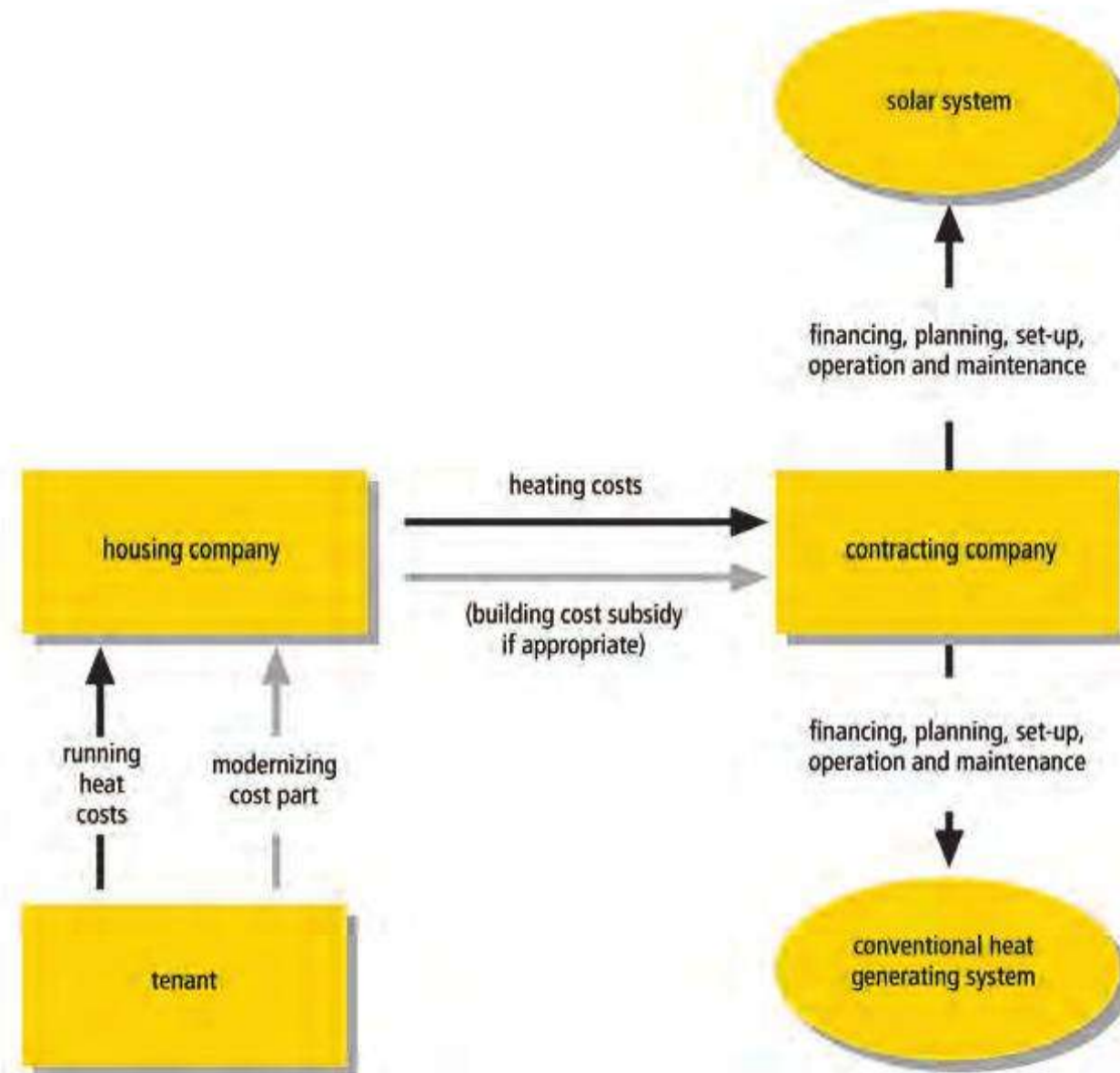

Figure 5.18.
Heat supply model, solar contracting

The twin-sourced generated heat is sold to the heat consumer. The heat consumer can be either the housing company or the direct tenant. The contractor is therefore interested in the best possible operation of the overall system including the solar thermal system. The optimum operation of the solar thermal system is reduced to its running operating costs. The investment and operating risk is transferred to the contractor. The housing society improves the renting potential on the current market by practising environmental protection and the use of advanced technology.

The supply of solar heat by means of solar contracting contributes to an improved market penetration for large solar thermal systems in the building of multi-storey flats for rent. The contractor (heat supplier), through his specialist expertise helps to overcome the existing market reluctance, such as lack of know-how or lack of confidence in the functionality of solar thermal systems.

The remaining additional costs for solar thermal systems under the present financial boundary conditions can be further reduced by the use of standardized large systems and larger quantities in contracting.

Solar contracting may also be eligible for grants within the scope of solar subsidy programmes. The contractor knows about the various solar grants that are available, undertakes management of the grant, and thus relieves the building owner of the responsibility.

Of course, building owners can also independently install conventional heat generation systems and supplementary solar thermal systems at their own expense and thereby at their own risk. As a rule, however, contracting solutions are economically more advantageous from the customer's point of view. The sample calculations in Tables 5.7 (for € or \$) and 5.8 (for £) should make this clearer.

Tables 5.7 and 5.8 compare the apportionment costs for self-operated building heating by the building owners with the equivalent costs for district heating, conventional contracting and solar contracting. The calculation is based on a new building project in Hamburg of two multi-storey blocks of flats with 70 dwelling units with 5000 m² (53,820 ft²) of total living area using a low-energy building method. The thermal connection rating is 250 kW, and the total heat requirement for room heating and hot water is 400 MWh.

Table 5.7.
Cost comparison: self-operated natural gas heating boiler, district heating, conventional contracting. Solar contracting, actual market situation in Hamburg (gross), prices in € or US\$

Position	Unit	Self-operated gas heating boiler	District heating (coal/gas fired)	Conventional contracting	Solar contracting
Central heating systems	€ or \$	57,520		53,686	53,686
Solar thermal systems	€ or \$				51,129
Planning	€ or \$	6902		6442	10,481
Hamburg solar programme	€ or \$				15,339
BAW grant	€ or \$				12,782
Capital costs (8%)	€/a or \$/a	7527		7025	10,184
Fuel/district heating costs	€/a or \$/a	18,410	28,379	16,748	14,878
Operating, maintenance	€/a or \$/a	1519	623	1626	2124
Mixed heat price	€/MWh or \$/MWh	68.5	72.6	63.4	68
Apportionment costs	€ or \$ per m ² per month	0.45	0.48	0.42	0.45

Table 5.8.
Cost comparison: self-operated natural gas heating boiler, district heating, conventional contracting. Solar contracting, actual market situation in Hamburg (gross), prices in £

Position	Unit	Self-operated gas heating boiler	District heating (coal/gas fired)	Conventional contracting	Solar contracting
Central heating systems	£	40,264		37,580	37,580
Solar thermal systems	£				35,790
Planning	£	4831		4509	7589
Hamburg solar programme	£				10,737
BAW grant	£				8947
Capital costs (8%)	£/a	5269		4918	7129
Fuel/district heating costs	£/a	12,887	19,865	11,724	10,415
Operating, maintenance	£/a	1063	436	1138	1487
Mixed heat price	£/MWh	48.0	50.8	44.4	47.6
Apportionment costs	£/m ² per month	0.32	0.34	0.29	0.32

The conventional heat generator consists of a natural gas boiler. The gas price corresponds to a special customer tariff, and the district heating price corresponds to the standard tariff. The existing purchasing advantages on the part of the contractor for system technology and primary energy have been taken into account. The solar thermal system has an absorber surface area of 100 m² (1076 ft²) with a total yield of 45,000 kWh/a.

The solar contracting solution achieves approximate price parity with heating apportionment costs of €0.45/\$0.45/£0.32 per m² per month compared with self-operated heat generation. In comparison with the conventional contracting solution, the solar contracting solution must compete with the additional monthly apportionment costs of about €0.03/\$0.03/£0.02 per m². In comparison with the district heating solution all other solutions investigated provide price advantages. This shows that a solar contracting solution lies within the range of the normal apportionment heating costs for heat supply. The heating costs for buildings, for example in Hamburg, currently lie within a range of €0.51–1.31/\$0.51–1.31/£0.36–0.92 per m² per month. On top of this the erection of a solar thermal system increases the attractiveness and hence the rentability of the flat.

The cost relation between a conventional self-operated heat generator and solar contracting essentially depends upon the fuel prices and the investment costs for the solar thermal system. For an energy price increase of 5% per annum the graph shown in Figure 5.19 arises for three of the investigated cases (self-operated heat generation, conventional and solar contracting).

The solar contracting solution shows a lower dependence on the natural gas price increase than the conventional contracting solution by the solar-generated part. Both contracting solutions have cost advantages over self-operated heat generation.

The investment costs of solar thermal systems depend heavily on the size of the system. Large surface area collectors can be made and installed more economically. Systems with collector surfaces of 30 m² (323 ft²) or more are suitable for solar contracting.

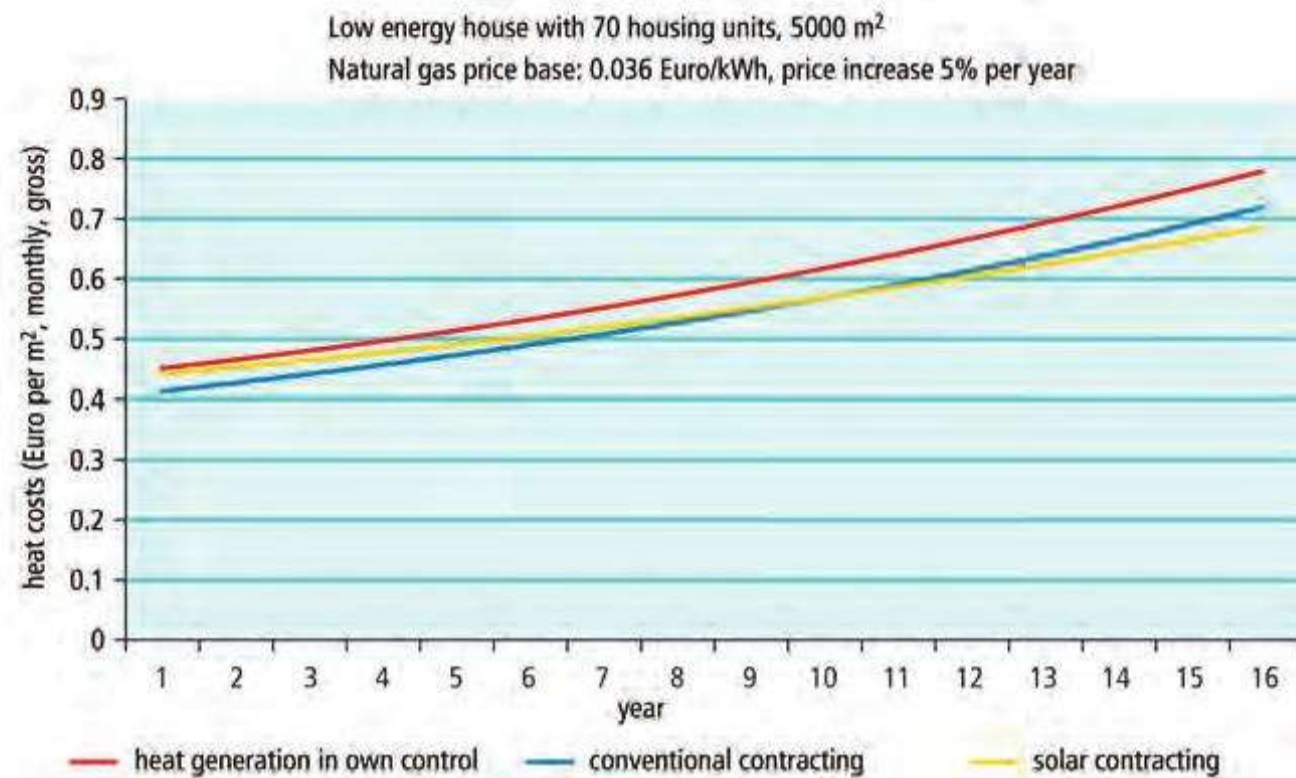

Figure 5.19.
Development of apportionment heating costs based on a natural gas price increase of 5% p.a.

The precondition for successful implementation of solar contracting projects is the suitability of the building and of course the existing interest of the building owner in contracting the heat generation out to a third party. The solar thermal system must be incorporated at an early stage in the planning. In the case of the building, the roof slope (structural strength, restoration requirements, alignment, pitch and shading), and the work of incorporating the hydraulics (solar circuit piping, space available for buffer tank in the heating room) must be taken into account.

As a rule the contracting company offers a standard heat supply contract in which, during the contract period, the heat price, price adaptation, maintenance and repair service, calculation methods, liability and insurance of the heat generating plant are accurately controlled.

If all the above preconditions are met, solar contracting offers the private building owners or the housing co-operative, without any additional costs (or with only a low level of such costs, depending upon the local subsidy situation), a calculable, solar-supported heat supply without having to carry great risks themselves. This takes place to the benefit not only of both contract partners, but also to that of the environment.^{38,39,40,41}

5.8 Solar district heating

Here we are talking about local supplies of heat for heating and hot water to small housing estates, or to building complexes such as hospitals (Figure 5.20).

In solar-supported district heating systems the heat is fed into a local heating network from one or many collector fields, and from there it is distributed to the connected households. A short- or long-term storage tank is coupled into the heat distribution network.

The concept of solar-supported district heating systems has come into consideration mainly in connection with the building of new housing estates or large building complexes that have been designed as low-energy buildings, as an environmentally friendly supply variant. It is important in such projects that, from the outset, the best possible technical preconditions are created for the use of solar energy by means of integrated energy planning. These include:

- a plan of the development with the orientation of the buildings that are favourable for active and passive use of solar energy (south alignment)
- planning of the estate or buildings according to solar architectonic criteria
- increased thermal protection in the buildings (low-energy building method)
- low-temperature heating systems, which permit a low network return temperature and hence a higher solar yield
- central heating plants and storage tanks arranged centrally to minimize distribution losses
- sufficient space for the heat storage tank.

Solar-supported district heating systems represent an inexpensive and ecologically sensible concept for the utilization of solar thermal energy if the technical conditions are suitable.



Figure 5.20.
This 3000 m² collector surface area system in Ry, Denmark, supplies the estate in the background by a district heating network

5.8.1 Solar energy systems with short-term heat storage

In solar district heating systems with short-term storage, buffer storage of several cubic metres of capacity is integrated into the network. The design of such systems is done on the basis of a solar fraction of 80–100% of the domestic water heating requirement in the summer months. This gives a solar fraction of 40–50% of the annual domestic water requirement – that is, around 20% of the total requirement for space heating and hot water generation.

In comparison with small local systems in individual buildings, large solar energy systems, which feed heat into a central heat supply, can be installed for less than half the investment costs:

- Small systems for one-family homes with about 5 m² (54 ft²) of collector surface cost around €960/\$960/£670 per m².
- Large systems with over 100 m² (1076 ft²) of collector surface cost around €500–600/\$500–600/£350–420 per m².
- Local area heating systems with several hundred to several thousand m² of collector surface cost about €360/\$360/£252 per m².

5.8.2 Solar systems with long-term heat storage

A solar-supported local heating system with long-term storage supplies larger housing estates of more than 100 dwelling units with both hot water and space heating. The

time offset between the solar radiation available in the summer and the maximum heating requirement in the winter is compensated for by the seasonal thermal storage system. The pilot systems in Germany are designed for a solar fraction of about 50% of the total heat requirements. Solar district heating systems with long-term thermal storage are currently still in the development phase.

5.8.3 Guide values for the design of solar district heating systems

The design of solar-supported district heating systems must be carried out by means of detailed calculations taking account of the size of the housing estate, the thermal insulation standards, and the solar fraction to be achieved.

Table 5.9 contains guide values for the rough dimensioning of a solar district heating system.

Table 5.9.
Guide values for rough
dimensioning of a solar district heating
system

System type	Solar district heating with short-term thermal storage	Solar district heating with long-term thermal storage
Minimum system size	From 30–40 housing units or 60 people	From 100–150 housing units (each with 70 m ² living area)
Collector surface area	1–1.3 m ² /person	1.4–2.4 m ² /MWh per annum 0.14–0.2 m ² per m ² living area
Storage tank volume	70–100 litres/m ² collector surface	1.5–4 m ³ /MWha 1.4–2.1 m ³ per m ² collector area
Useful solar energy	350–500 kWh/m ² a	230–350 kWh/m ² a
Solar fraction	Hot water 50% Total 10–20%	Total 40–70%

5.8.4 Components of solar district heating systems

5.8.4.1 STORAGE TANKS

As short-term storage tanks, either steel buffer tanks in the standard sizes (up to 6 m³; 212 ft³), in which the desired total volume can be achieved by connecting several individual tanks in succession, are used, or special custom-made designs are arranged. Different principles are used in the selection of long-term heat storage systems.

EARTH RESERVOIRS

This storage system is designed as a concrete container that is either partially or completely submerged in the earth. It is lined to seal it against vapour diffusion, and is thermally insulated. The storage medium is water (Figure 5.21).

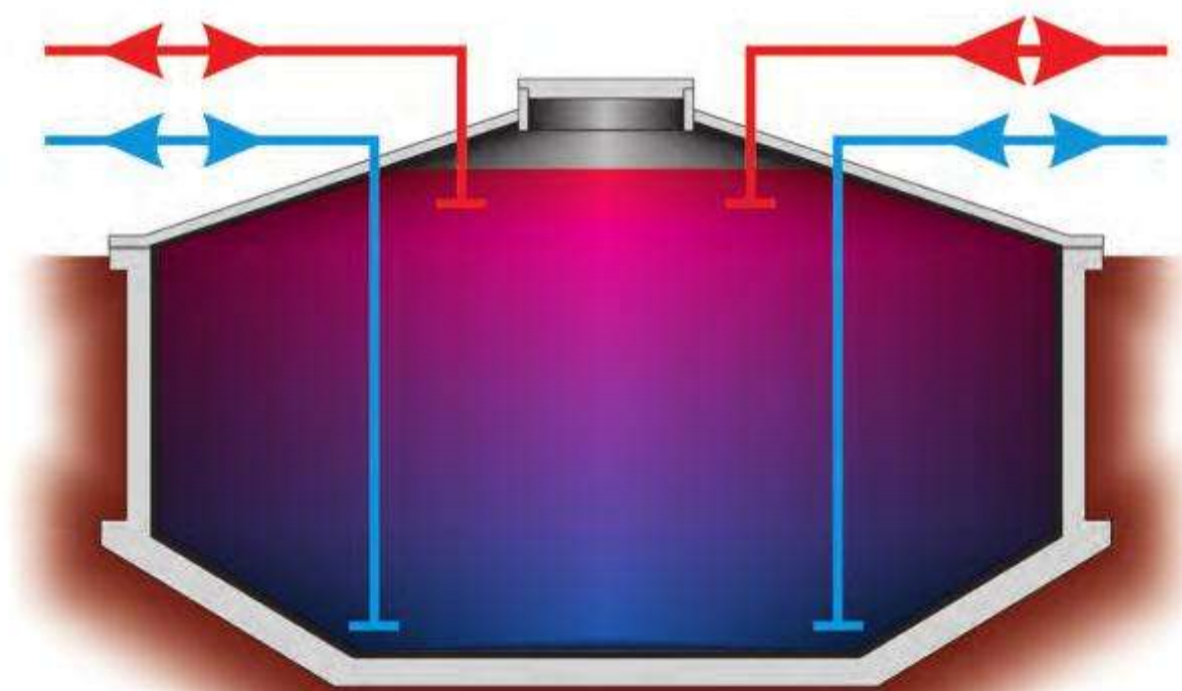

Figure 5.21.
Earth reservoir

Practical German examples include:

- Hamburg-Bramfeld: Tank structure with nozzles; thermal insulation in wall area 20 cm (7.8 inches), in the cover area 30 cm (11.8 inches); volume: 4500 m³ (158,916 ft³).

- Friedrichshafen-Wiggenhausen: Self-supporting concrete structure, thermal insulation in wall area 30 cm (11.8 inches), in the cover area 40 cm (15.7 inches); volume: 12,000 m³ (423,776 ft³); approximately €120/\$120/£84 per m³ installed volume; internally lined with a 1.2 mm (0.05 inches) thick stainless steel foil vapour diffusion seal.

Another variant, the gravel/water storage tank, is constructed more simply. A pit lined with a water-tight plastic film is filled with a gravel/water mixture as the storage medium. The storage tank is thermally insulated at least at the side and the top.

Practical example:

- Chemnitz: Storage tank with a gravel/water filling that takes on the structural function of the walls; storage volume 8000 m³ (282,517 ft³) with 5300 m³ (187,168 ft³) water equivalent; €140/\$140/£98 per m³ water equivalent; good seal is achieved by a 2.5 mm (0.1 inches) thick HDPE (high density polyethylene) film.

EARTH PROBE STORAGE SYSTEM

For this type of storage system, heat exchanger pipes are laid horizontally in the earth or vertically into drilled holes (U-tube probes), and are thermally insulated up to the surface. The surrounding soil is used directly as the storage medium, and heats up or cools down. Practically any size of storage volume is possible. The soil characteristics however, play an important role (Figure 5.22).

Practical examples:

- Neckarsulm: Storage volume around 175,000 m³ (6,180,067 ft³).
- Arnstein: Approximately 3000 m³ (105,944 ft³) storage volume; utilization about 36%.

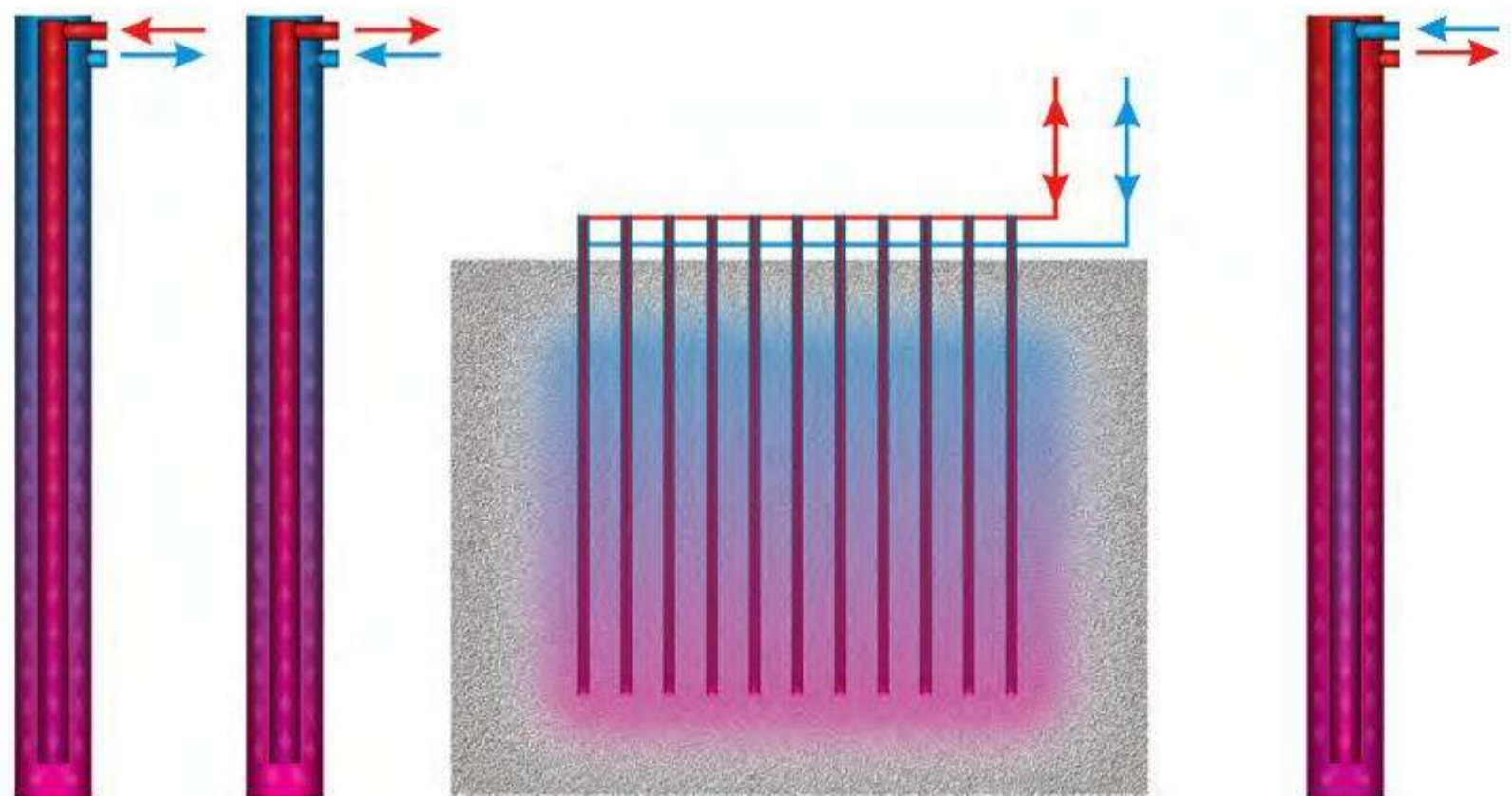

Figure 5.22.
Earth probe storage system

AQUIFER STORAGE SYSTEM

Holes are drilled in pairs into water-bearing earth layers to depths of 50–300 m (164–984 ft). Warm water is pumped into the soil, which serves as the storage medium, by means of a borehole (well); the water is subsequently discharged through another borehole. There is no need for thermal insulation. Soil formations with low groundwater flow speeds are necessary.

Practical example:

- Berlin: Within the scope of the reconstruction of the Reichstag (Government building) and the neighbouring buildings, two aquifer storage systems were implemented for cold storage at 60 m (197 ft) deep and hot storage at 300 m (984 ft) deep (in combination with a heat pump and a vegetable oil: CHP).

5.8.4.2 DISTRICT HEATING NETWORKS

Various different network structures can be used for distributing the heat:

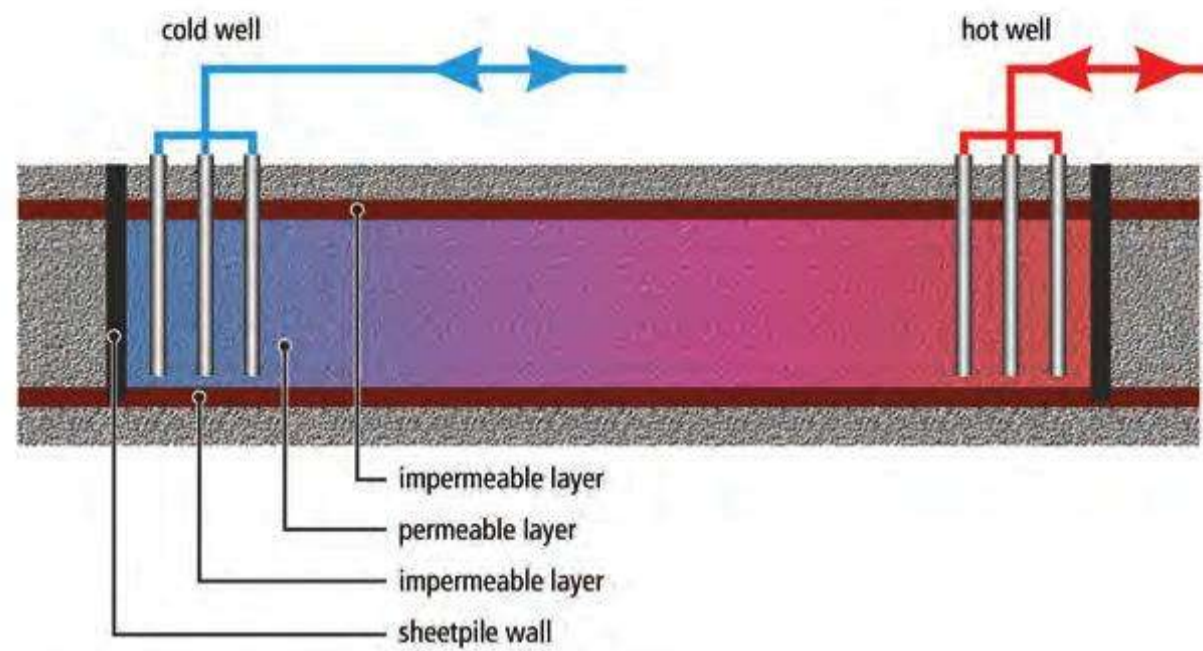

Figure 5.23.
Aquifer storage system

- **2+2 conductor network.** This comprises two conductor lines for the heat supply to the buildings (domestic water heating takes place locally in the individual buildings), and an additional two conductor lines for the solar circuit.
- **4+2 conductor network.** This comprises four conductor lines for the heat supply: two lines each for domestic hot water (DHW) and space heating, plus an additional 2 lines for the solar. It permits central domestic water heating, but results in higher circulation losses.
- **3 conductor line network (two variants).** An (older) variant uses a separate supply for the space heating and water heating together with a common return. In connection with solar district heating a system supply, a common return and a solar supply are now frequently used (newer variant).

5.8.4.3 HOUSE CONNECTING STATIONS

We can differentiate here between two main connecting options to the building: direct and indirect integration of heating.

Direct connection, without an intermediate heat exchanger, is cheaper and involves lower heat losses. *Indirect heating* decouples the district heating network through a heat exchanger from the lines in the building. This variant is usually preferred by house-owners.

5.8.5 Practical experience

The pilot systems with short- and long-term heat storage systems implemented so far have shown that this new – and still unfamiliar – technology brings with it a high requirement for information as well as minor problems. However, all systems have been put into operation without great difficulties. The solar systems operate well and reliably, and the long-term heat storage systems fulfil expectations. The main problems involve their combination with conventional system technology, together with their dimensioning and implementation.

In almost all systems, return temperatures that were too high occurred in the heat distribution network. Often it was simply that heaters that were too small were installed and operated, which made low return temperatures impossible. In one example this was due to faulty regulation of the internal house heating system by an average of 10–15 K higher than the value established by load simulations. The high return temperatures of the heat distribution network (monthly average up to 55°C (131°F)), on the one hand, led to high storage temperatures and hence to low collector efficiencies; on the other hand the heat storage could not be discharged to the pre-calculated low temperatures. In this way, part of the heat content was not used in the storage. Since then, return temperatures have been reduced to a value of maximum 45°C (113°F).

More information on operating experience can be found in *Professional Experience with Solar District Heating in the German Project Friedrichshafen / Wiggenshausen-Süd*.⁴²

In general, the initial operating results have shown that through the solar energy system and the linked detailed instrumental monitoring of the whole plant, previously unrecognised operating problems involved in conventional system technology have

been made evident. These difficulties cannot therefore be set against solar systems, as they occur in many buildings without solar energy systems and have often not been detected. On the contrary, the use of a solar energy system with the corresponding instrumentation leads to the finding and rectification of these problems. Optimization of the solar energy system yield hence always requires optimization of the conventional system technology.

6 Solar concentrating systems

The temperature level that can be achieved with non-concentrating solar thermal collectors is limited. At the most a level of approximately 200°C (392°F) can be reached with high-end vacuum tube collectors. A further increase of temperatures beyond this level is technically hardly achievable. In addition, above 100°C (212°F) the collector efficiency decreases significantly. However, looking at the required temperature levels in the market segments of process heat or electricity generation by thermal processes, far higher temperatures are needed. Such temperatures can only be generated by the concentration of sunlight.

6.1 Concentration of solar radiation

Concentration of sunlight for large-scale applications is commonly done with reflecting concentrators; lens systems cannot be used owing to their high price and limitations in size. Instead, a parabolic-shaped reflector concentrates the solar radiation either on a focal line or on a focal point. The concentrator needs to track the sun, so that its incident rays are always perpendicular to the aperture area.

In principle, the main choice is between one-axis and two-axis tracking systems (see Figures 6.1a–6.1c). Systems with one-axis tracking concentrate the sunlight onto an absorber tube in the focal line of the concentrator, whereas two-axis tracked systems focus the rays of the sun onto a round-shaped absorber at the focal point.

The theoretical upper value of concentration is 46,211; it is limited by the fact that the sun is not a point source of radiation. By concentrating solar radiation a maximum temperature of 5500°C (9932°F) – the temperature of the sun's surface – can be achieved. However, in practice these maximum values have never been reached, and in general they are not needed in any case. With a rising concentration ratio, the theoretical temperature limit also increases. In practical applications, operating temperatures commonly do not even come close to the theoretically possible temperature (see Table 6.1). There are two main reasons for this: first, it is not possible to manufacture or install to the ideal and, second, heat is carried away, which continuously reduces the temperature. However, if the heat removal is interrupted, the temperature in the absorber can rise dramatically.

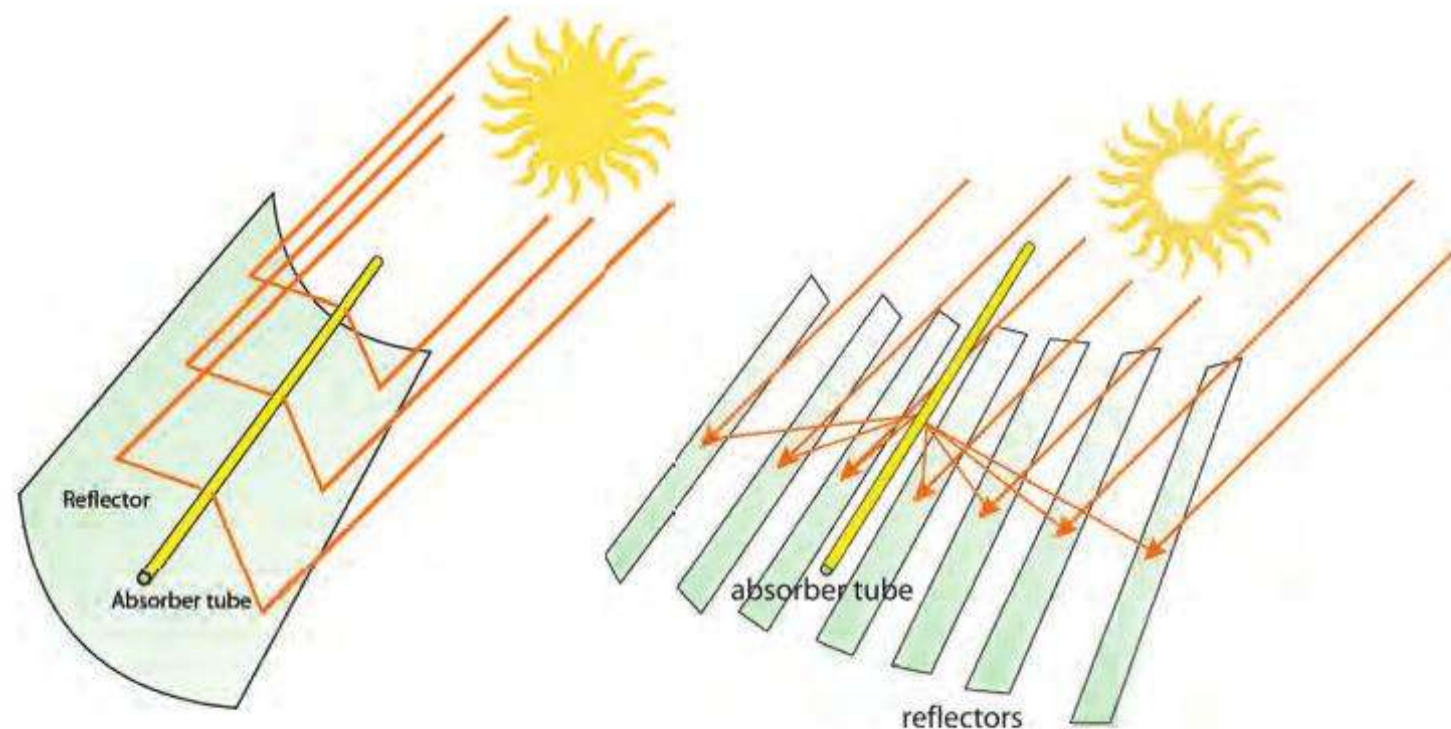

Figure 6.1a.
Concentration of solar radiation:
reflectors with one-axis tracking

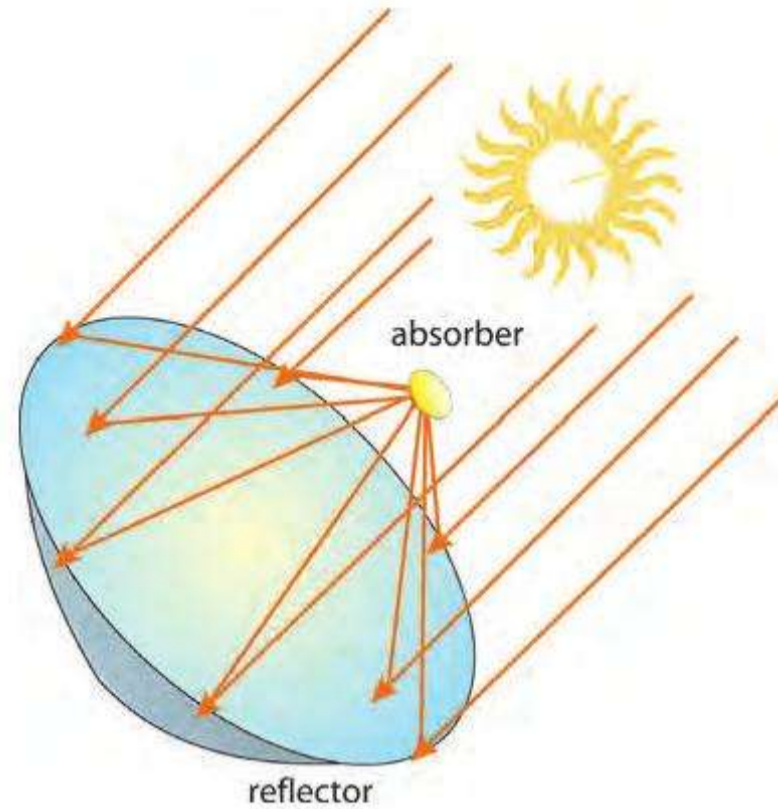

Figure 6.1b.
Concentration of solar radiation: single reflector with two-axis tracking

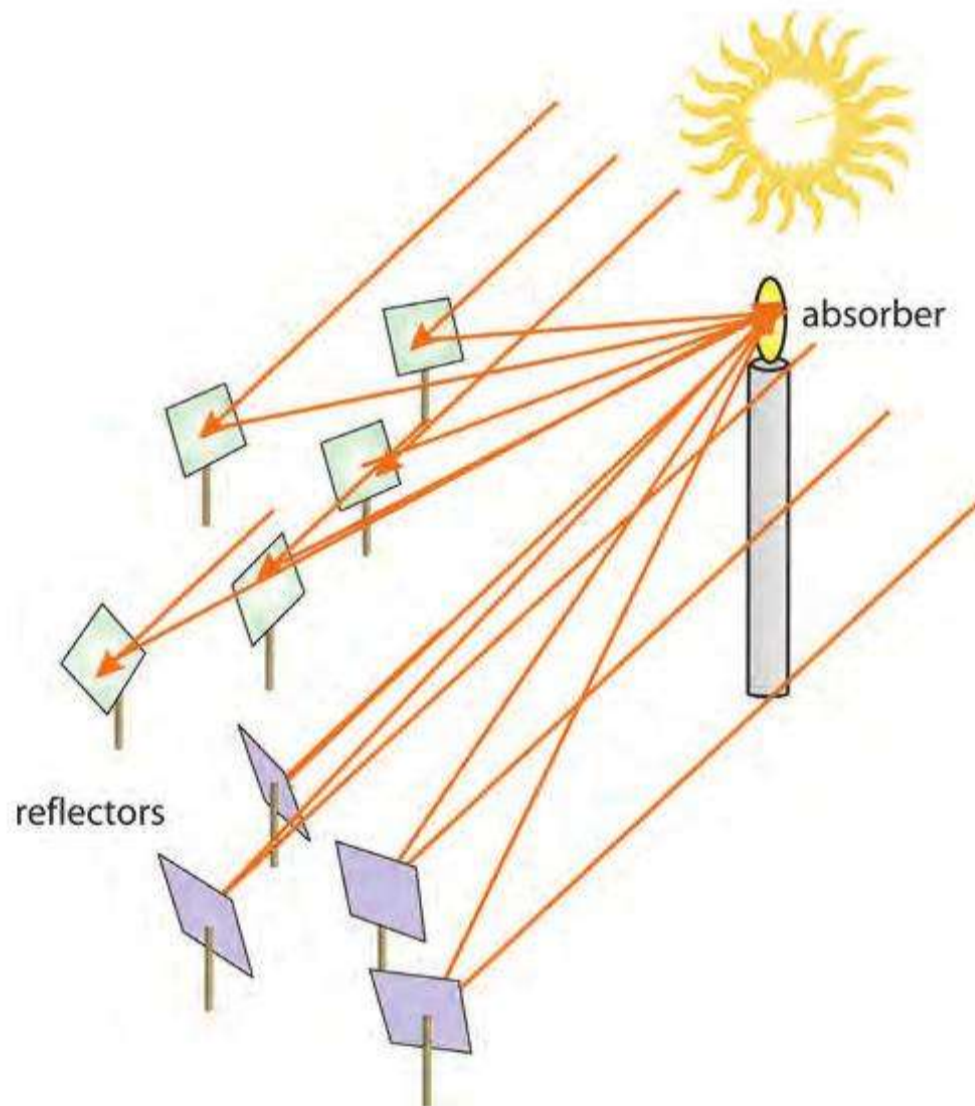

Figure 6.1c.
Concentration of solar radiation: multiple reflectors with two-axis tracking

6.2 Concentrating systems providing process heat

The generation of energy- and cost-efficient heat at temperature levels above 150°C is possible only with solar systems that make use of concentrating collectors, in contrast to non-concentrating systems or collectors with low concentration ratios (such as compound parabolic concentrators). Commonly the demand for process heat is strong in the temperature ranges 80–250°C (176–482°F) and from 900–1500°C (1652–2732°F). Of particular interest is the market segment for low-temperature process heat from 80–250°C (176–482°F). Applications operating in this temperature range have used approximately 300 million MWh annually in the EU (8% of the end energy demand). The chemical industry, the pulp and paper and textile industry and the food processing industry consume large parts of this heat. The areas of application are numerous and include not only such widely varying processes as the heating of baths (for example for electroplating or cleaning), drying, chemical processes

Table 6.1.
Concentration ratios of various
systems

Collector type/system	Concentration ratio	Operating temperature (°C)	Theoretical temperature limit (°C)
Parabolic trough collector LS-3 and EuroTrough	82	~400	910
Solar tower plant with REFOS-pressurised receiver	~500	~1100	1590
EuroDish (dish/Stirling) system	2500	650	2510

(thermal separation, for example), melting or boiling, but also the generation of low-temperature process steam and the supply of heat to drive absorption refrigeration systems (solar cooling).

A selection of concentrating collectors was presented in section 6.1. With regard to the economic aspects of the provision of process heat, *parabolic trough collectors* are of particular interest. These concentrate the incident direct solar radiation linearly by means of parabolic curved reflectors onto a black-coated absorber tube. The aperture span of these collectors usually ranges between 2 and 4 m (6.6 and 13.1 ft). The absorber tube takes up the solar radiation and converts it to heat, which it transfers to the heat transfer fluid that flows in the tube. Commonly used heat transfer fluids are water (hot water or steam), air and also thermal oils. Generally the latter re-transfer the heat to water or air in a heat exchanger at a further stage of the line.

Compared with glazed flat-plate collectors, these systems exhibit fewer heat losses. Among other aspects, this results from the small absorber surface area compared with the aperture (solar radiation collection area) and the selective coating of the absorber tube, which reduces the emittance of infrared radiation and thus radiation losses. In addition, a glass envelope that sits around the absorber tube reduces convective losses. In order to achieve even higher collector efficiencies, and thus make it possible to reach higher operating temperatures, the space between the glass envelope and the absorber tube is evacuated.

A tracking device – commonly a motor and a transmission device – enables the parabolic trough collector to follow the sun on one axis. Parabolic trough collectors are usually installed with a north–south orientation. This orientation results in a higher annual energy yield than an east–west orientation. However, the latter orientation shows a more even distribution of the annual energy yield. In the case of two-axis tracking the requirements for construction, control and maintenance are higher and so therefore are the costs, so that the one-axis-tracked parabolic trough has proven itself as the more reliable and more efficient system. Further developments in parabolic trough technology aim at improving optical efficiencies while using less material.

A further significant difference between tracked concentrating collector systems and the conventional solar thermal systems such as glazed flat-plate collectors or evacuated tube collectors is shown in the operation and safety concepts.

In conventional collector systems, if a standstill occurs (for example if no heat is removed, or if a component fails) then in order to prevent stagnation temperatures being exceeded, various substantive measures (such as expansion vessels) have to be incorporated. In contrast, tracked collectors make use of safety control routines that defocus the collector to avoid exceeding stagnation temperatures. However, suitable safety devices, such as a flow indicator, are needed to ensure the flow of heat transfer fluid through the absorber, and thus the removal of heat, before the collector is focused, in order to avoid overheating of the system.

Some evacuated tube collectors integrate compound parabolic concentrators (CPCs) into the glass envelope (see Figure 6.2) in order to enhance the aperture. Also simple flat absorber stripes are used for that purpose.

Figure 6.3 shows the efficiency of various collector types by plotting the annual energy yield per square metre of collector surface area against the mean flow temperature. Whereas the energy yield for non-concentrating collectors decreases significantly with increasing flow temperature up to a maximum temperature of 100°C (212°F), the decrease is considerably less for evacuated tube collectors with CPCs and parabolic trough collectors. The common non-tracking glazed flat-plate collectors and evacuated tube collectors use the entire solar radiation (that is, the direct irradiation and the diffuse sky irradiation), in contrast to concentrating solar systems, which use

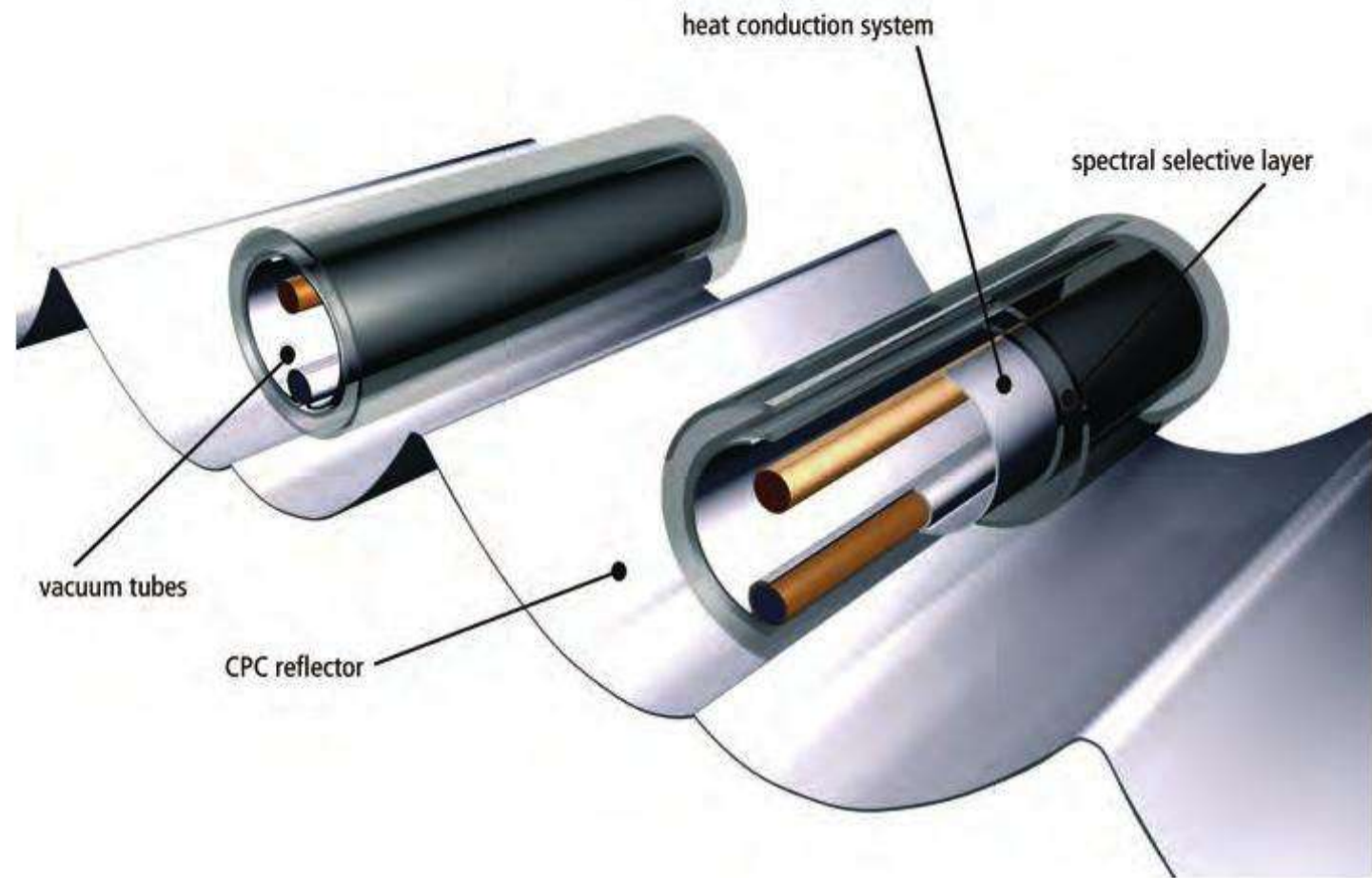

Figure 6.2. Schematic structure of a CPC tube collector. Source: Consolar

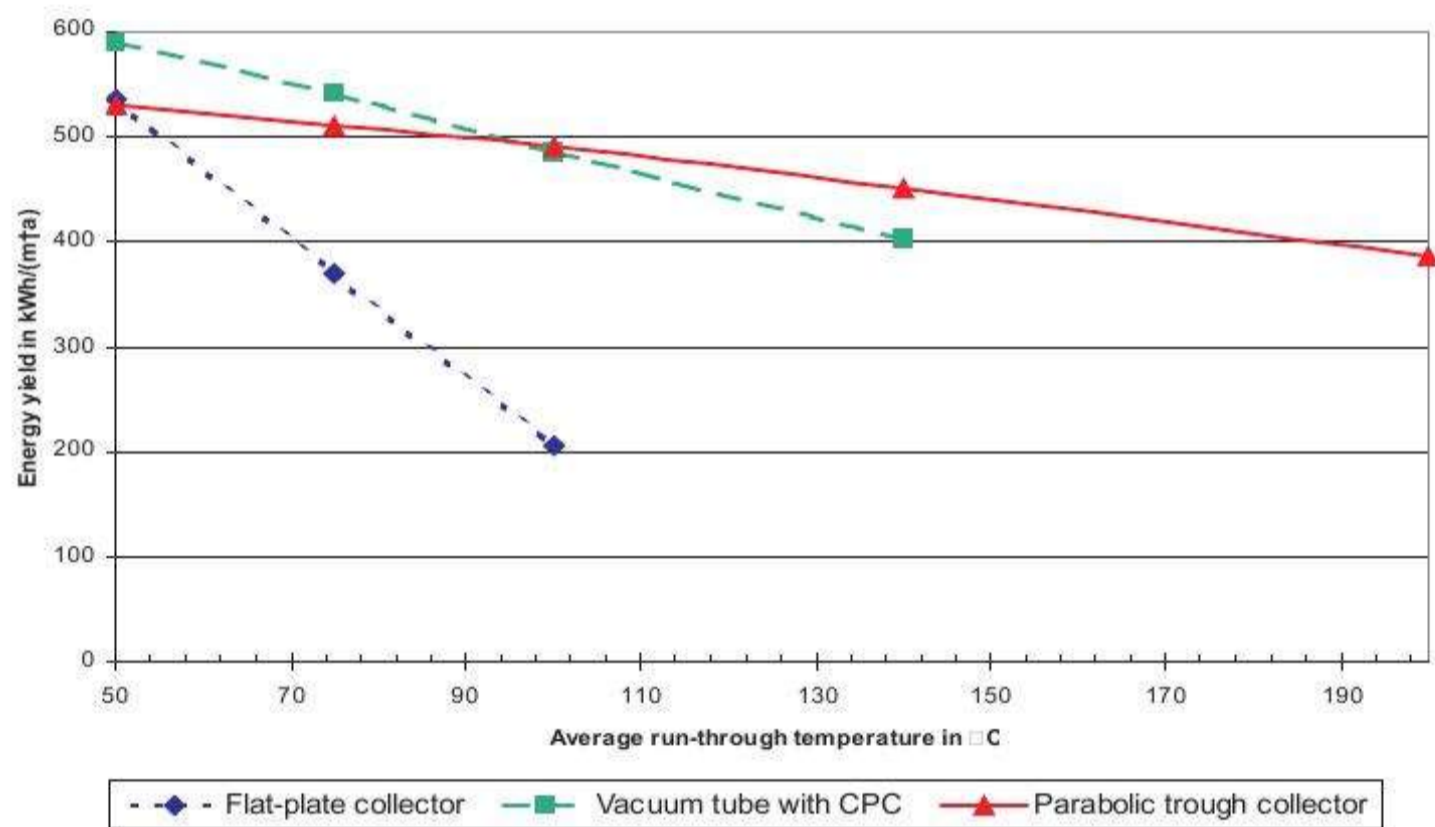

Figure 6.3. Energy yield against mean flow temperature for various collector types at Würzburg, Germany. Source: Klaus Hennecke

only the direct irradiation. The energy yield in Figure 6.3 was calculated for southerly oriented collectors with an inclination angle of 40°, located in the city of Würzburg, Germany.

The energy yield of a collector system depends not only on the construction of the collector but also on the annual amount of direct irradiation. Würzburg receives a mean annual direct irradiation of 533 kWh/m²a. Comparison of parabolic trough collectors of simple construction with conventional solar thermal collectors shows that, even in a mid-European climate, the parabolic trough collector has a number of advantages, in particular when higher operating temperatures are needed. At southern European locations with a higher share of direct irradiation the advantages become even larger.

The system integration of concentrating collectors to provide process heat does not differ much from conventional systems that supply process heat. The centrepiece of the system is the collector field: that is, arrangement of the collectors on the ground or on the roof of a building. The heat transfer fluid (HTF) circulates through the field. By measuring the temperature of the HTF at the outlet of the collector, a controller regulates the flow rate in harmony with the irradiance. The gained heat is then

transferred to a heat exchanger, where it is either used directly in a process (for example to heat a bath or to preheat feed water or combustion air; see Figure 6.4) or stored in a short- or long-term heat store.

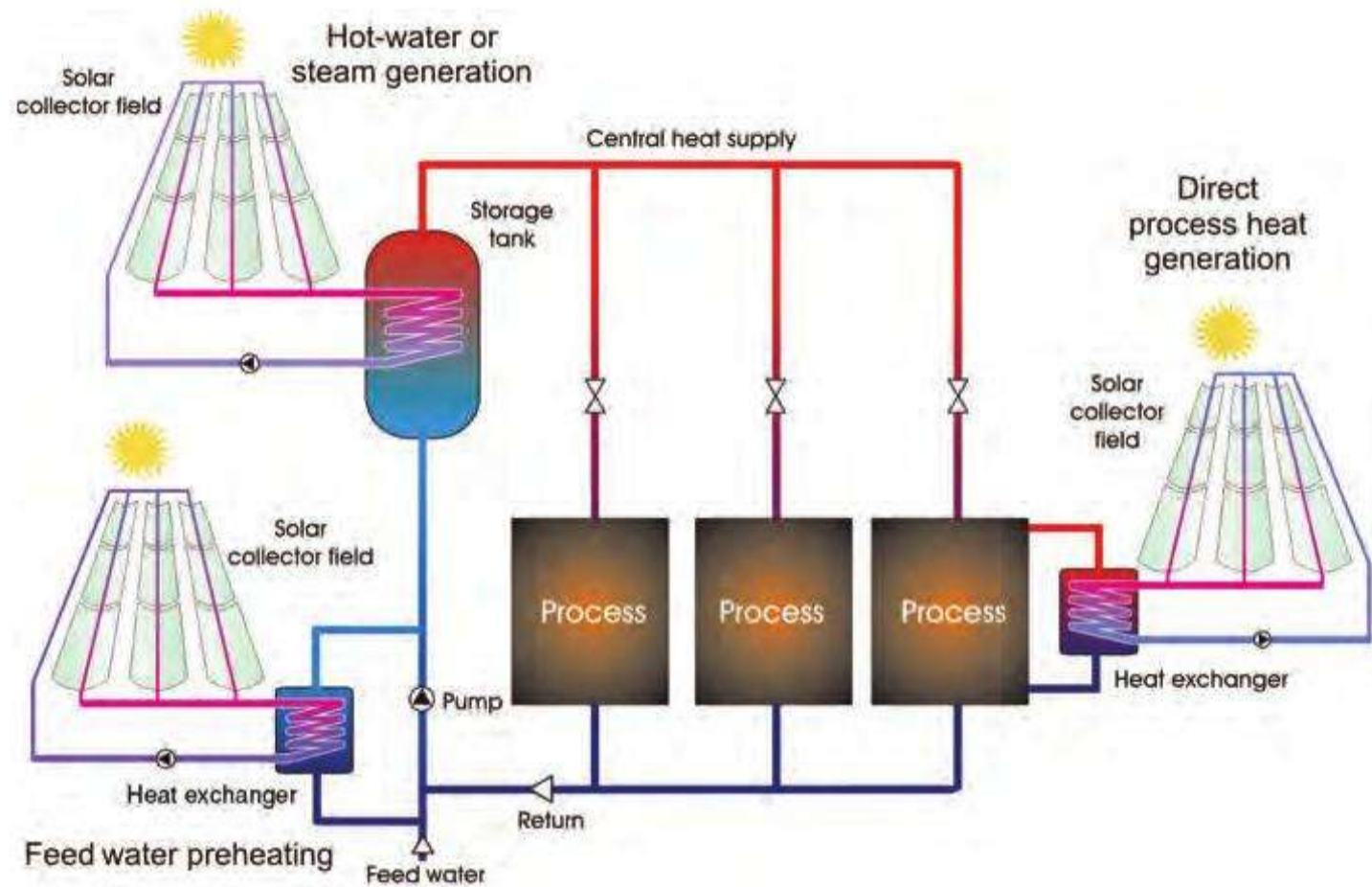

Figure 6.4. Schematic of various options for integrating solar systems into a conventional heat supply. Source: DLR

The simplest and most cost-effective integration is the direct input of solar heat into the process (see upper picture in Figure 6.5). This variant only makes sense if the respective process runs continuously and the heat demand is larger than that being provided by solar energy. The schematic shows an indirect system in which the collector circuit is separated for freezing and corrosion reasons from the application process by a heat exchanger. For economic motives the dimensioning of the collector field should ensure that the maximum solar energy yield does not exceed the heat demand at any time.

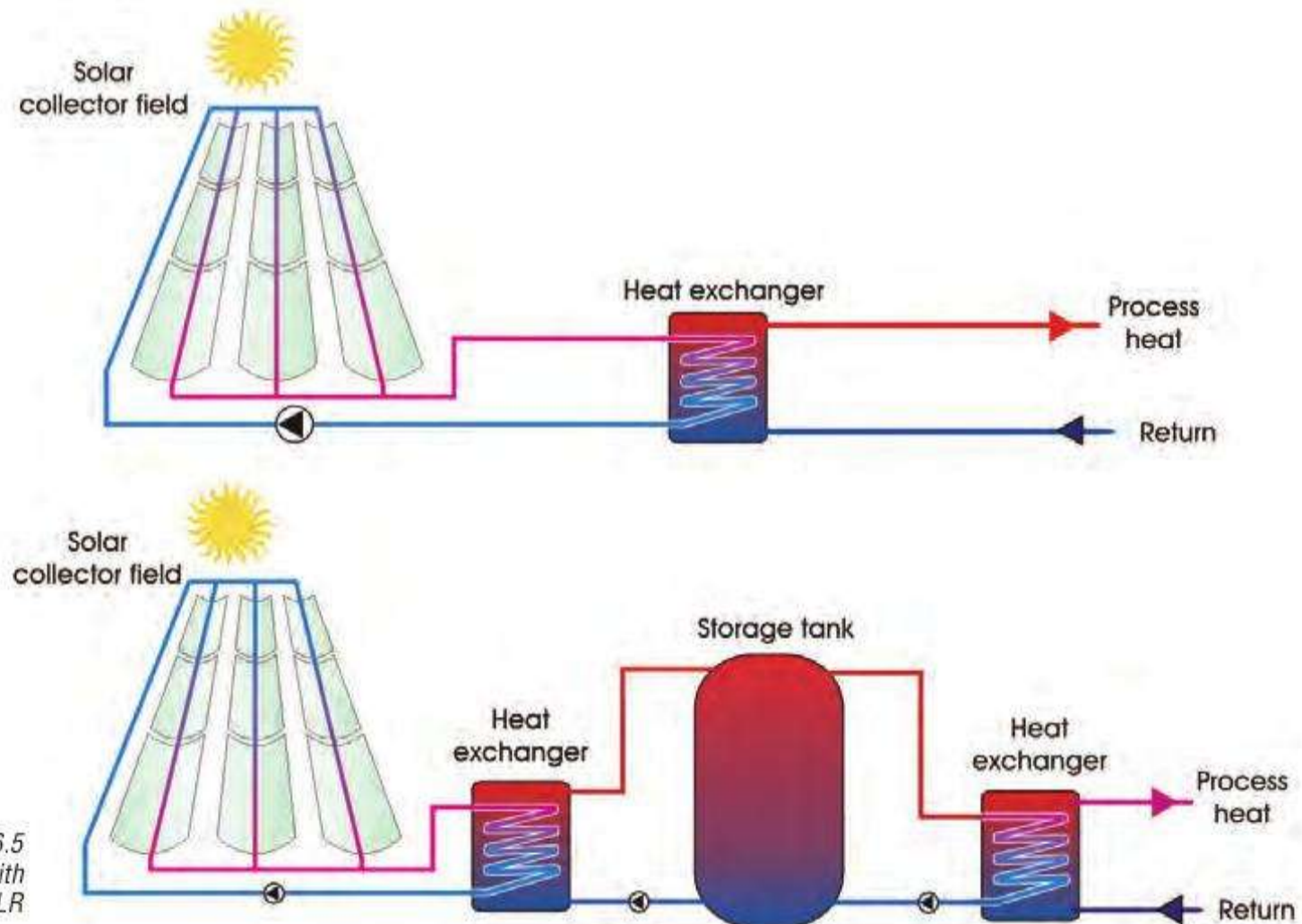

Figure 6.5 Solar system without (above) and with storage (below). Source: DLR

More common are processes that are operated for only 5–6 days a week, or processes with frequent interruptions. Such situations require the use of a store for any excess heat. The required heat can then be supplied to the user whenever it is needed. In this case the dimensioning of the store and the collector field depends not only on the

required heat demand, temperature level and system design, but also on the desired heat capacity of the storage, and thus the amount of time for which heat can be supplied. In general a distinction is made between: short-term storage with a capacity of a number of hours, which covers daily fluctuations; storage systems with a capacity for several days; and seasonal storages. The store has to be dimensioned according to the specific demand.

In contrast to solar thermal power plants for electricity production, solar thermal process heat systems should be installed directly at the location where the heat is required in order to avoid losses caused by the need to transport the heat. Hence sufficient space for the collector field and a relatively high annual irradiation need to be available at the specific location.

Typical investment costs for a solar thermal process heat system are given in Table 6.2.

Table 6.2.
Investment costs for various
collector types (indicative; market prices
fluctuate and differ per country)

Collector type	Costs (€/m ²)
Flat-plate collector	250–300
Compound parabolic concentrator (CPC)	300–350
Parabolic trough collector	300–400
Evacuated flat-plate collector	400–600
Evacuated tube collector	400–600
Evacuated tube collector with CPC	400–600

The maintenance costs (cleaning etc.) for conventional collectors are of the order of €2.5/m²a; for parabolic trough collectors they amount to approximately €5/m²a.

Considering the costs for the total system and the single components, about 80% of the investment cost relates to the collector field (for field sizes of >1000 m² (>710,764 ft²)), including the erection, support structure and piping. The remaining 20% relates to the heat exchangers, pumps, control system and planning. Whereas the integration of short-term storage does not influence the investment costs significantly, long-term storage tanks can be far more costly, reaching shares of 10–20% of the total investment cost.

The total investment costs for solar thermal systems for process heat are about €250–1000/\$250–1000/£165–600 per kW_{th} (kilowatt-thermal) of installed capacity. Accordingly the resulting energy costs are about €0.02–0.05/\$0.02–0.05/£0.014–0.035 per kWh_{th} for low-temperature heat supply, and €0.05–0.15/\$0.05–0.15/£0.035–0.10 per kWh_{th} for mid-temperature heat.

For the near future it is important to demonstrate the integration and reliability of solar thermal process heat systems in suitable applications. One obstacle for such systems is the availability of space to erect the collector field. Higher specific costs compared with those of conventional process heat systems are another barrier. However, cost reduction potentials are seen in modifications of the collector designs, and in smaller, modular collector units that are suitable for erecting on a rooftop or for roof integration. Further potential is expected from increasing automated operation, thus reducing the operation and maintenance (O&M) costs. Mass production, the reduction of O&M costs and the improvement of system design and collector efficiencies were expected to cut costs by half by the year 2010.

Until now the European market did not offer concentrating systems for process heat applications. However, several current European projects are aimed at the development of commercial collectors, and some companies in Israel and the USA already offer commercial systems. Also, a number of systems are operating in the USA, with collector field sizes ranging from 200 to 3000 m² (2153 to 32,292 ft²).

In addition, with the 'Campaign for Take-Off' the European Commission is pursuing the aim of having 2,000,000 m² (21,527,821 ft²) of solar thermal collectors installed for industrial process heating and solar cooling. By reaching this goal, it is expected to realize a saving of prime energy of about 2 million MWh/a. In 2001 solar thermal collectors with a total area of 10,000 m² (107,639 ft²) were operating in the field of industrial process heat in Europe. In the near and mid-term future, concentrating collectors could play an important and growing role in the spreading of supplying solar process heat.

6.3 Concentrating solar thermal systems for electricity generation

The use of approximately 1% of the surface area of the Sahara for solar power plants would be sufficient to meet the entire global electricity demand. Solar thermal power plants, in particular, offer the opportunity to produce solar electricity in the tropics at low cost. These power plants do not use the photo effect like photovoltaic systems, but apply thermal processes to generate electricity. There are three different types of solar thermal power plant:

- parabolic trough plants
- solar tower plants
- dish/Stirling systems.

6.3.1 Parabolic trough plants

The first solar thermal power plants were developed in the USA in 1906. The first demonstration plants were erected and successfully tested in the USA and near Cairo, Egypt, still a British colony at that time. Amazingly, these systems looked almost like the systems of today. However, problems with materials and other technical difficulties put an end to the first attempts at large-scale solar electricity generation in 1914, shortly before the outbreak of the First World War.

In 1968 the USA laid the foundation for the renaissance of solar thermal electric technology. The US public electric utilities were obliged by the power of the Public Utilities Regulatory Policy Act to buy electricity from independent power producers at a clearly defined tariff. After a doubling of the electricity costs in only a few years owing to the oil crisis, the Californian electric utility Southern California Edison (SCE) offered long-term conditions for the feed-in of electricity from renewable energy systems. In combination with tax incentives such as an exemption from paying property tax for solar power plants, the development of solar thermal power plant projects started to become financially interesting. In 1969 the company LUZ was founded, which concluded a feed-in contract for solar thermal electricity over a period of 30 years with SCE in 1983. The first commercially operated solar thermal power plant with parabolic trough technology was erected in 1984. From then on new solar thermal power plants with increased size and improved technology followed each year (see Table 6.3). In the mid 1980s electricity prices went down again. After the abolition of tax exemptions at the end of 1990, LUZ went bankrupt just before starting the erection of its tenth solar thermal power plant.

Table 6.3.
Characteristics of different parabolic
trough collectors

Collector type	LS-1	LS-2	LS-3	EuroTrough
Year of first installation	1984	1986	1988	2001
Concentration ratio	61	61	82	82
Aperture width (m)	2.5	5.0	5.76	5.76
Collector length (m)	50	48	99	150
Aperture (m ²)	128	235	545	825
Absorber tube diameter (mm)	42.4	70	70	70

Although electricity generation from solar thermal power plants is significantly cheaper than from photovoltaic systems, no further commercial solar thermal power plants have been built since 1991. However, a number of new solar thermal power plant projects are currently being developed. The World Bank has allocated US\$200 million for financial support of the erection of combined solar thermal and natural-gas-fired power plants in developing countries such as Egypt, Mexico, India and Morocco. In Spain, an increased feed in remuneration exists.

Until a few years ago, solar thermal power plants with parabolic trough technology were the only commercially operating plants. After the oil crisis nine parabolic trough plants were erected between 1984 and 1991 in the Mojave Desert in California on a surface area of more than 6 km² (2.3 square miles). They are called *SEGS plants* (solar electric generation systems) (see Figure 6.6 and Table 6.4). More than a million mirror elements with a total aperture of 2,300,000 m² (24,756,994 ft²) focus the sunlight in these plants, which have an electrical capacity of 354 MW. Each year the SEGS plants

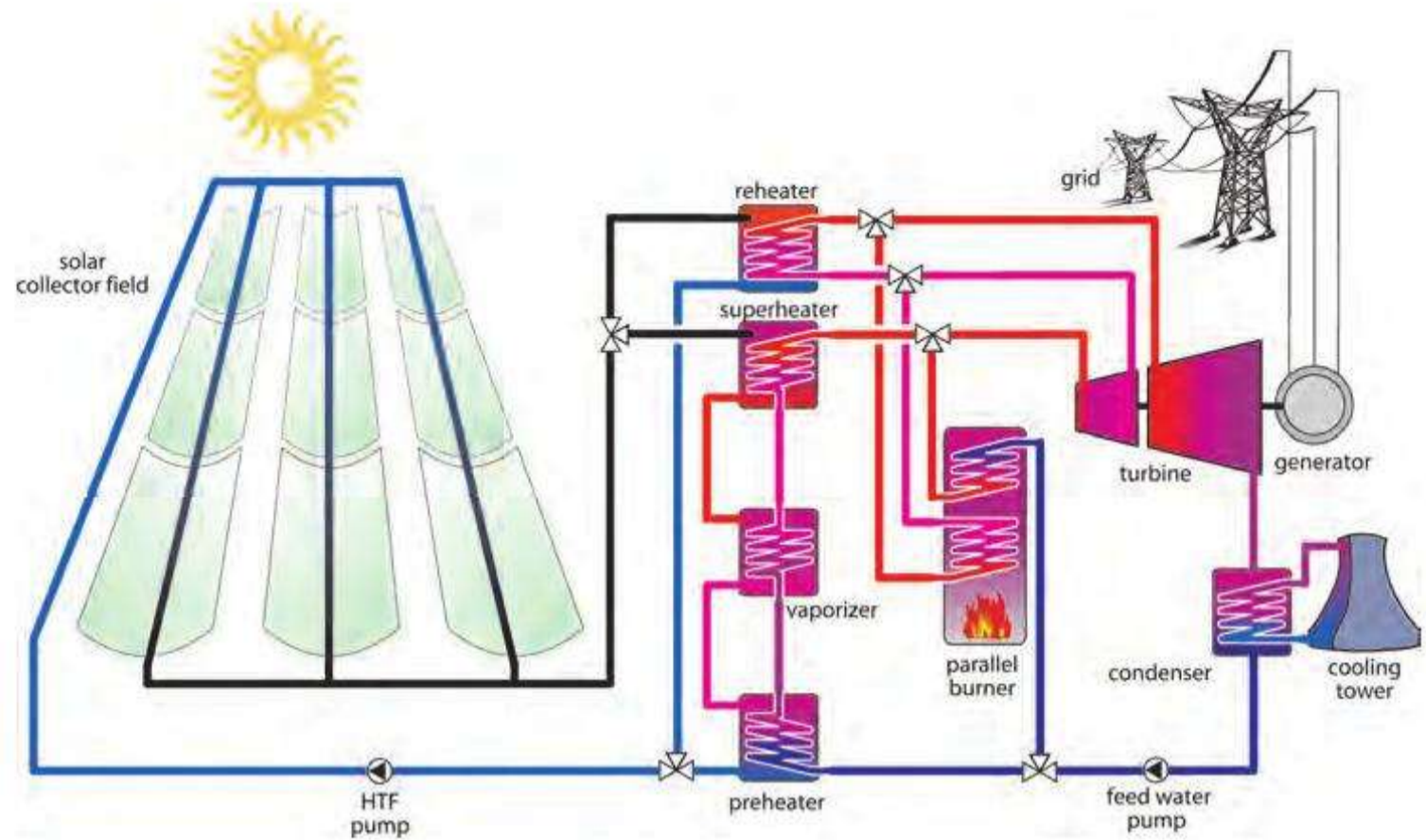

Figure 6.6. Schematic of an SEGS plant

Table 6.4. Technical data for parabolic trough-based SEGS plants in California

Plant	I	II	III	IV	V	VI	VII	VIII	IX
Year of commissioning	1984	1985	1986	1986	1986	1988	1988	1989	1990
Net capacity (MW)	13.8	30	30	30	30	30	30	80	80
Land use (1000 m ²)	290	660	800	800	860	660	680	1620	1690
Aperture (1000 m ²)	83	165	233	233	251	188	194	464	484
HTF outlet temp. (°C)	306	321	349	349	349	391	391	391	391
Efficiency (%)									
– Steam turbine (solar)	31.5	29.4	30.6	30.6	30.6	37.6	37.6	37.6	37.6
– Steam turbine (gas)	–	37.3	37.3	37.3	37.3	39.5	39.5	37.6	37.6
– Solar field (thermal) ^a	35	43	43	43	43	43	43	53	50
– Solar-to-electric (net) ^a	9.3	10.6	10.2	10.2	10.2	12.4	12.3	14.0	13.6
Specific invest. costs (US\$/kW)	4490	3200	3600	3730	4130	3870	3870	2890	3440

^a Design

generate about 800 million kWh of electricity, enough to cover the demand of 60,000 Americans. Eight of the SEGS plants can also be operated with fossil fuels, so that electricity can be supplied during night-time or periods of bad weather. However, the annual share of fossil fuel, in this case natural gas, is limited by law to 25% of the entire annual thermal input. The total investment for the SEGS plants amounts to more than US\$1.2 billion. Up to now these plants have supplied more than 10 billion kWh of electricity to the grid. The levelized electricity costs have decreased from system to system, with US\$0.26/kWh for the first SEGS plant down to US\$0.12–0.14/kWh for the plants that were erected last.

The principle of operation of the parabolic trough plants is easy to understand. Large reflectors, arranged in the form of a trough-shaped collector, focus the sunlight onto a focal line. Several collectors are joined together in rows of 300–600 m (984–1969 ft) (Figure 6.7). Again, a number of parallel rows then form the entire solar field.

Each single collector can be turned around its longitudinal axis to track the sun. The sunlight is concentrated up to 80 times onto an absorber tube that is located in the centre of the focal line. A glass envelope is placed around the absorber tube in order to reduce heat losses. Heat radiation losses are minimised by applying a special high-temperature-resistant selective coating to the absorber tube. In the Californian plants a specific thermal oil flows through the absorber tubes and is heated to temperatures of up to 400°C (752°F).

A parabolic trough collector can also be designed according to the Fresnel principle, as shown in Figure 6.8. Heat exchangers transfer the solar heat from the heat transfer fluid (HTF) to a water/steam cycle. The feed water is first brought up to higher pressure before it is preheated, evaporated and superheated by the HTF. The superheated steam drives a conventional steam turbine generator set to generate



Figure 6.7. Parabolic trough power plants in California. Source: KJC



Figure 6.8. Parabolic trough collectors. Source: Volker Quaschnig

electricity. In two-stage turbines with high- and low-pressure stages the steam is reheated between the two stages. Once leaving the turbine the steam is expanded and is then condensed to water before reaching the feed water pump again. In cases of bad weather or at night-time the steam cycle can also be operated with a parallel fossil-fuel-driven boiler.

In contrast to photovoltaic systems a solar thermal power plant can guarantee a daily security of supply. This aspect increases the attractiveness of solar thermal power technology in a power plant portfolio. A useful supply of electricity can either be realized by hybrid operation with fossil fuels or, if solar-only, CO₂-emission-free operation is desired, by using thermal storage (Figure 6.9). A well-proven principle in storing high temperature heat makes use of two-tank storage with, for example,

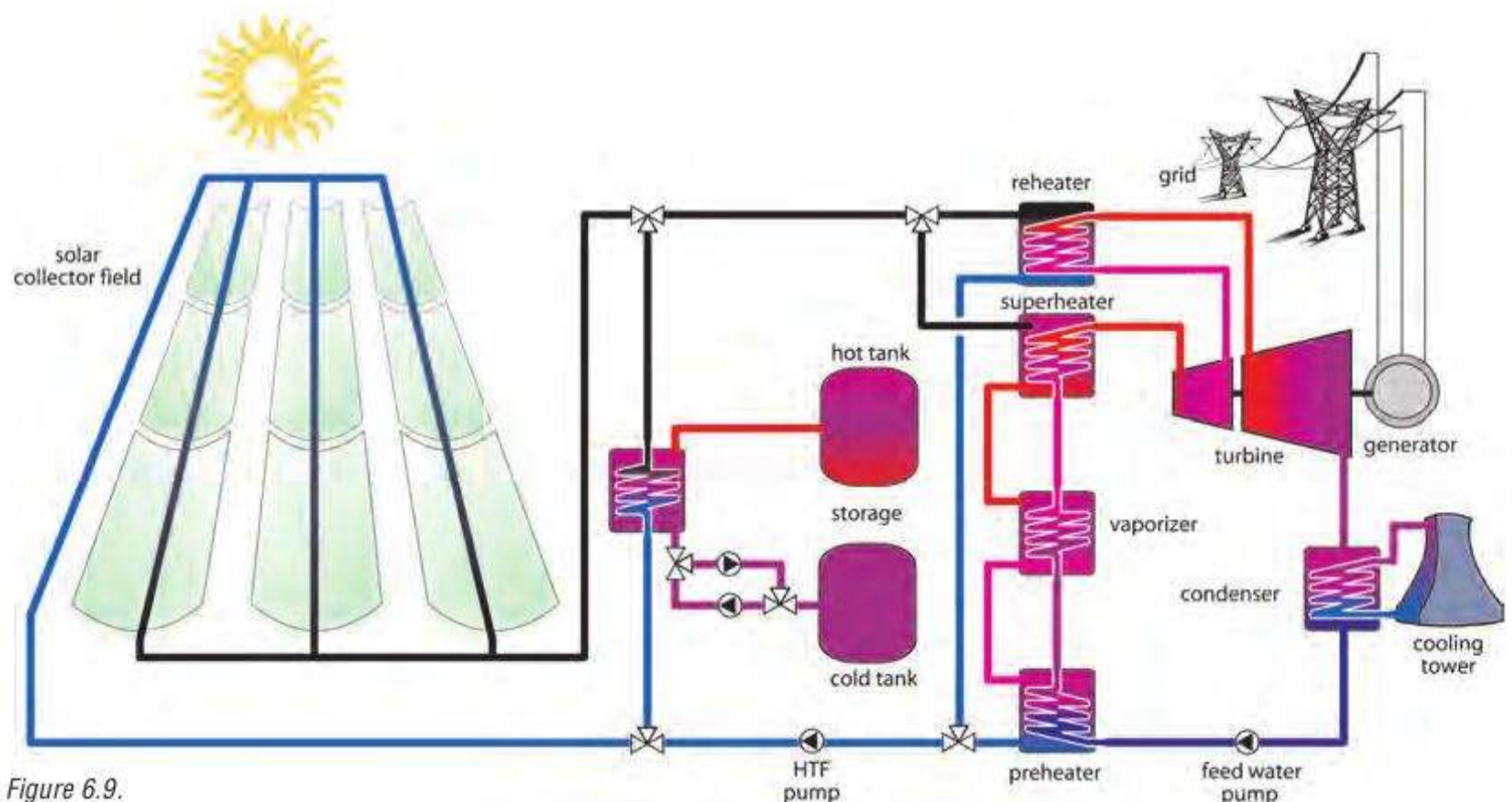

Figure 6.9. Schematic of a parabolic trough power plant with thermal storage

molten salt as a heat carrier. In the case of excess solar heat this is transferred via a heat exchanger to the molten salt, which is pumped from a warm to a hot store. In periods with less solar radiation the hot molten salt can be pumped back to the warm tank, heating up the HTF, which then drives the steam cycle.

The parallel steam generator (boiler) can also be fuelled by biomass or hydrogen (produced from renewable electricity). This is another option for generating electricity without emitting additional CO₂.

Current technological developments aim at further improvement of the efficiency and thus reduction of costs. For example, in Southern Spain close to the city of Almería the direct generation of solar steam is being demonstrated (Figure 6.10). Here the parabolic trough collectors directly heat and evaporate water under high-pressure conditions to a temperature of 400°C (752°F). Steam at such conditions can directly drive a steam turbine, so that such plants could dispense with the HTF and the heat exchangers.

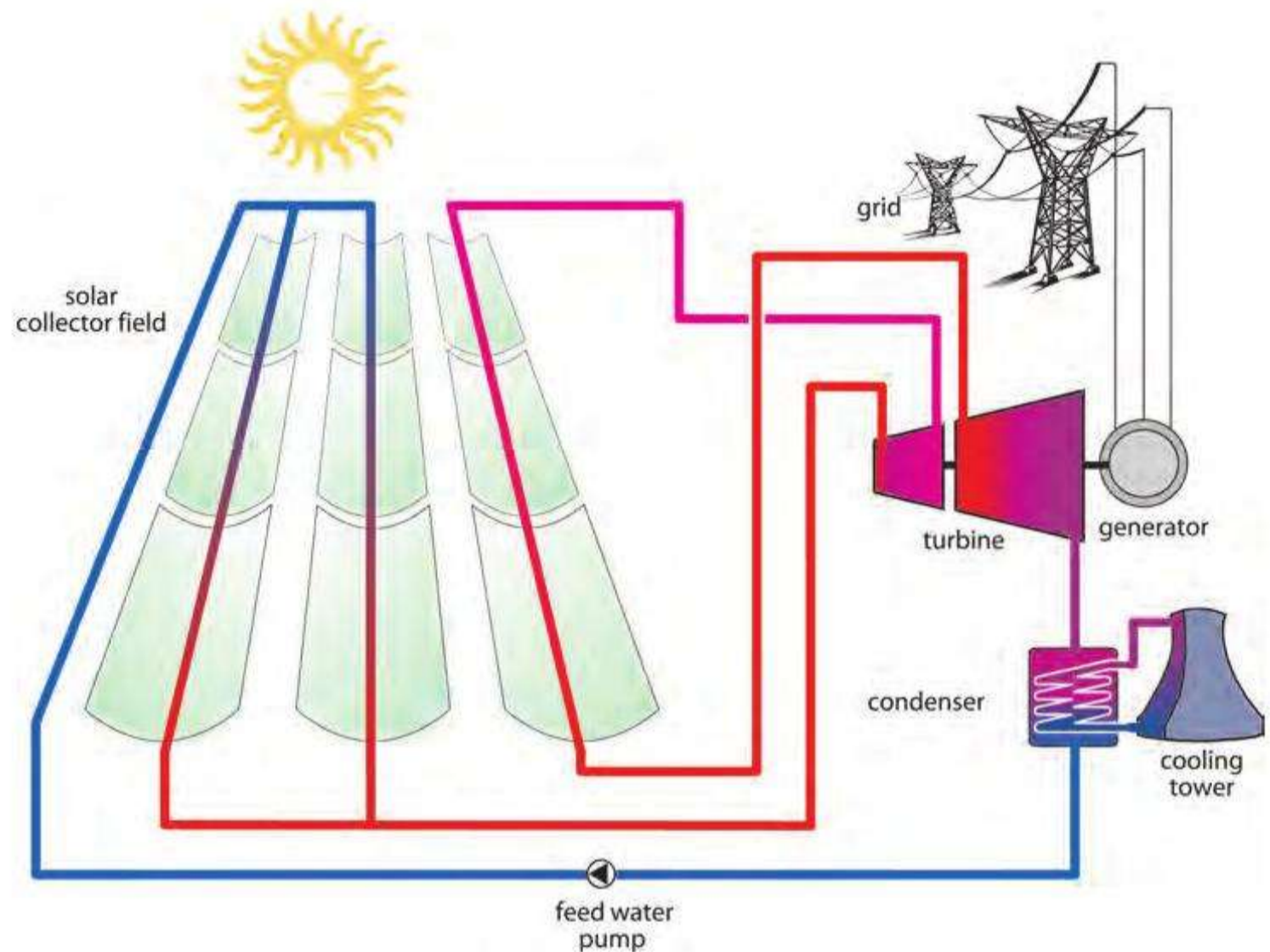

Figure 6.10.
Schematic of a parabolic trough plant
with solar thermal direct steam
generation

The largest potential cost reduction is expected from large-scale production of solar thermal power plants, thus making use of the economies of scale. On a long-term basis cost reductions from €0.15 down to €0.05 per kWh are seen as possible. This would drive costs down to a similar order of magnitude as those of conventional fossil-fuelled power plants, but without the emission of harmful greenhouse gases.

A NEW GENERATION OF PARABOLIC TROUGH SOLAR THERMAL POWER GENERATION

Between 2007 and early 2009, a new generation of parabolic trough plants have seen the light of day, built mainly in Spain. The plants, with a capacity of 50 MW each (Energia de Solar De Puertollano, Andasol, Alvarado 1), are paving the way for newer, even larger plants. In Spain alone, at the time of writing, two 150 MW, eight 100 MW and nine 50 MW parabolic trough power plants are under construction, representing more than 1.5 GW of newly realized solar thermal power generation through parabolic trough technology.

At least four of these new units incorporate massive heat storage facilities, enabling the generation of electricity for a significantly larger part of the day.

The following generation is also already in sight, with announcements in Spain of additional, even larger (up to 200 MW) parabolic trough plants with a combined planned capacity of around 1 GW.

In the USA a new generation of plants have also been announced, the largest of which exceeds 950 MW in capacity. The total announced capacity using this

technology in the USA exceeds 4.5 GW – a truly significant amount, making parabolic troughs a relevant and highly promising utility-scale generation technology.

New plants are also springing up outside of the ‘traditional’ areas of application, with plants announced in locations as far-flung as the Negev Desert and Abu Dhabi,

Looking somewhat further into the future, the recently announced DESERTEC initiative aims to locate concentrating solar power plants throughout the Middle East and North Africa to provide power to Europe, and it is probably a safe bet that a significant part of the massive systems required to make this initiative a reality will be parabolic trough systems.

In considering technological variations, it is interesting to see that the Fresnel-style collector type, mentioned above, is also finding both large and small scale practical implementation. Spain and Australia have seen plants between 1.4–2 MW of this type completed, and a 300 MW plant has been announced for California.

The technology scales well down to quite modest levels, with small Fresnel collectors for industrial process heat requirements being developed by companies like PSE GmbH in Germany.

6.3.2 Solar tower plants

Solar tower plants offer another option for producing solar thermal electricity. In this system several hundred, or even several thousand, reflectors are positioned around a central tower. Each of the reflectors, also called a *heliostat* (Figure 6.11), tracks the sun under computer control in order to focus the direct sunlight to the central receiver located at the top of the tower. The accuracy of the tracking is very important to ensure that the sun’s reflected rays reach the focal point.

An absorber is positioned at the focal point. The concentrated sunlight heats up the absorber to temperatures of more than 1000°C (1832°F). Air or molten salt transfers the heat to the power cycle – a gas or steam turbine cycle – where the heat is then converted into electricity.

In contrast to parabolic trough technology, no commercial tower plants are in operation, so far. In Almería (Spain), Barstow (USA) and Rehovot (Israel) pilot plants are operated in which system configurations are being optimized and new components are being tested (Figure 6.12). Also in Spain, the first commercial solar tower plants are in an advanced planning stage.

The tower concept with open volumetric receivers (Figure 6.13) works as follows. A fan sucks the ambient air into the receiver upon which the heliostats focus the sunlight. Commonly wire mesh, ceramic foam or a metallic or ceramic honeycomb structure is used as the receiver material. This structure is heated by the solar radiation and transfers the heat to the airflow. The ambient air cools the front part of the absorber, whereas very high temperatures arise in the rear part of the absorber material. Thus radiation losses are minimized. The heated air with temperatures between 650°C (1202°F) and 850°C (1562°F) is impelled to a waste heat boiler where water is evaporated and superheated. Again, the superheated steam drives a steam turbine generator set to produce electricity. This power plant variant can make use of other fuels, for example by means of a duct burner.



Figure 6.11.
Heliostats. Source: Volker Quaschnig

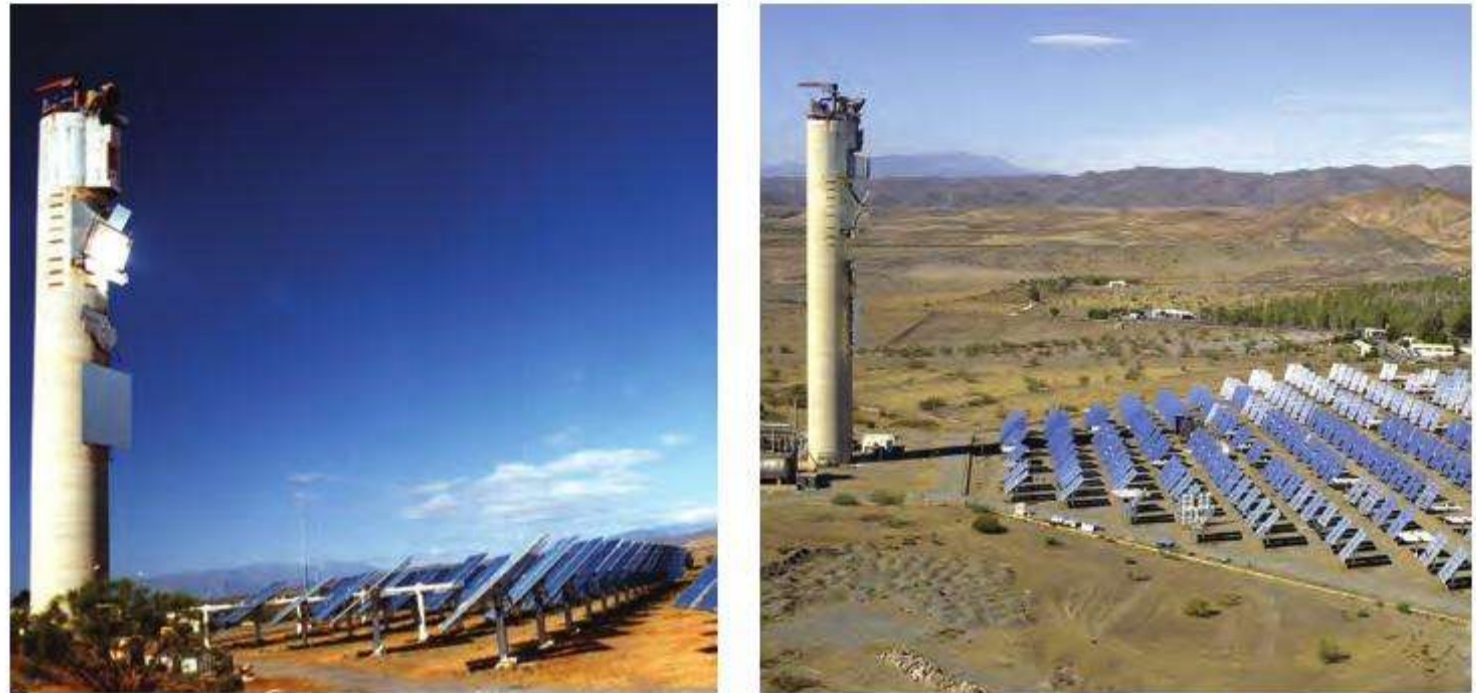

Figure 6.12.
Solar tower test installations in Almería,
southern Spain. Source: Stefan Franzen,
CIEMAT

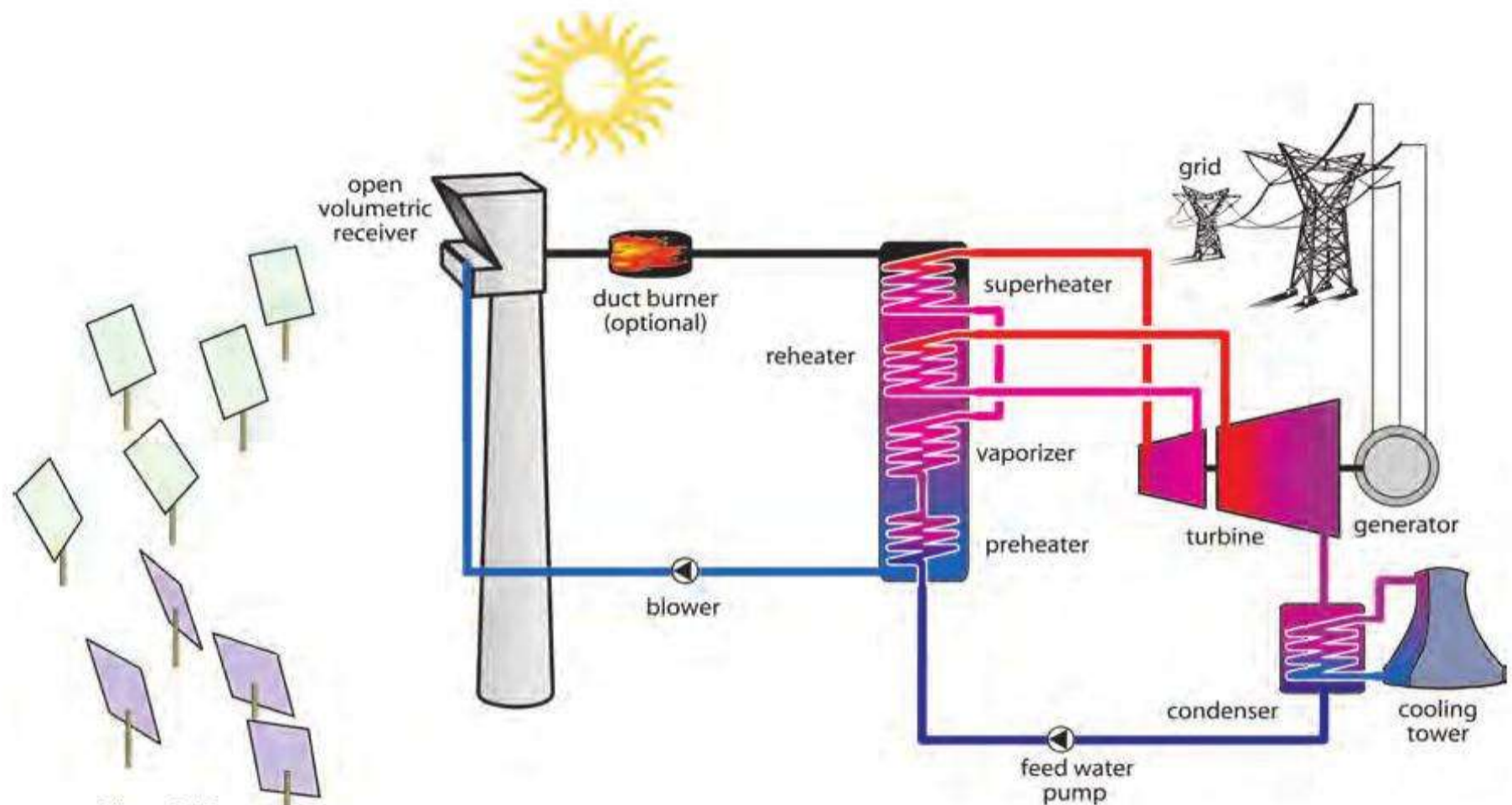

Figure 6.13.
Solar tower plant with open volumetric
receiver

Another tower concept that was developed from that just described offers promising options for the mid-term future: the closed volumetric receiver (REFOS concept; Figure 6.14). Here a transparent cupola-shaped silica glass separates the ambient air from the absorber. The air is heated in a pressurised air receiver at a pressure of approximately 15 bar (217.6 psi) to temperatures of up to 1100°C (2012°F). With air of this temperature level a gas turbine is driven. Downstream a steam cycle makes use of the waste heat of the gas turbine.

In general, electrical efficiencies of combined cycles are higher (in the range of 50%) than steam cycle efficiencies (about 35%). The integration of solar thermal energy into combined cycle processes allows solar-to-electric efficiencies of more than 20%. This improvement and its technological prospects justify the increased technological effort and the higher costs of this receiver technology.

The levelized electricity costs are expected to be slightly higher for the first commercial solar tower plants as, in contrast to parabolic trough power plants, there are no series-produced solar tower plants in operation. However, owing to the higher efficiencies that are possible, lower costs are expected in the medium term.

Solar towers are increasingly playing a significant role in the commercial concentrated solar power landscape. Following the completion of the PS10 and PS20 installations (at 10 and 20 MW capacity, respectively) in Spain, and the smaller 1.5 MW air-based tower in Jülich, Germany, a number of new solar tower projects are in planning or under construction.

These include another 17 MW unit under construction near Seville in Spain, and announced systems that vary from 400 MW (in San Bernardino County, California) to several new 200 MW units in the Mojave Desert. A further two units, at 50 and 20 MW respectively, have also been announced for Spain.

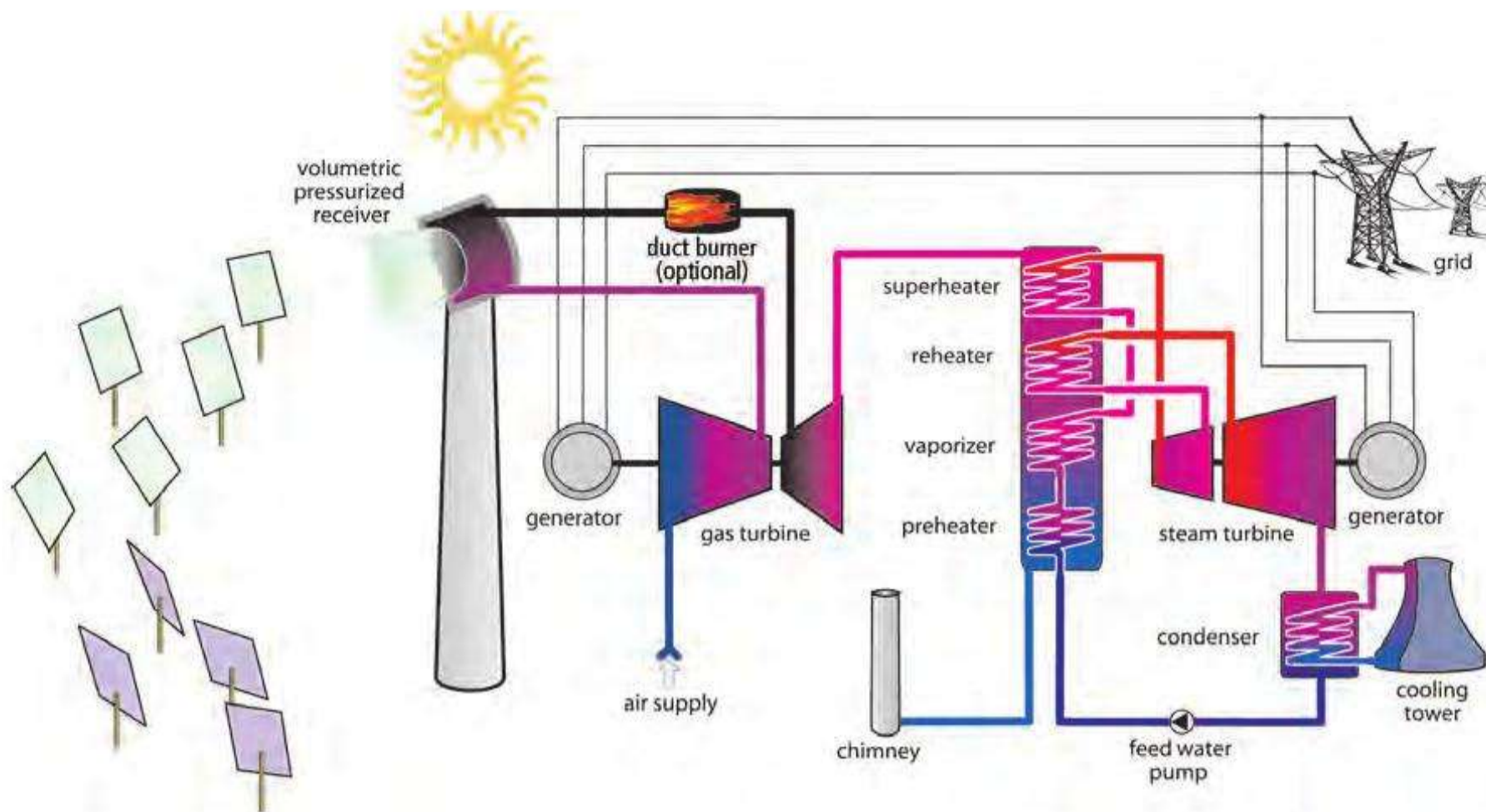

Figure 6.14.
Solar tower plant with a
pressurised volumetric receiver for
solar operation of gas and steam
turbines (REFOS)

While the total capacity still lags behind trough technologies, the numbers are significant and indicate that solar towers offer sufficient benefits to compete on the commercial market.

6.3.3 Dish/Stirling systems

Whereas the erection and commercial operation of solar parabolic trough and tower plants is economically viable at electrical capacities of several megawatts, dish/Stirling systems can be also used in smaller units, for example as stand-alone systems to supply remote villages with power.

In these systems a concave mirror in the shape of a large bowl concentrates the solar radiation to a focal point, where the receiver is located. In the receiver the solar radiation is converted into heat and transferred to the heart of the system, the Stirling engine. This engine converts the heat directly into kinetic energy, which drives a generator to produce electricity. In order to direct the solar radiation to the receiver it is necessary to move the concave mirror in two axes, hence tracking the sun.

Solar heat is not the only form of heat that can drive the Stirling engine; heat from any combustion process can also be used. Combinations with a biogas burner can enable the dish/Stirling system to produce electricity also during night-time or in periods of bad weather. The use of biogas in such a system is also entirely CO₂-neutral.

Some prototype dish/Stirling systems have been erected and operated in Saudi Arabia, Spain and the USA (Figure 6.15). The levelized electricity costs are still relatively high in comparison with those of solar tower or parabolic trough plants. However, a dramatic cost reduction is thought to be possible when such systems are produced in large numbers and in volume production.



Figure 6.15.
Dish/Stirling demonstration systems in
Almería, Southern Spain. Source: Volker
Quaschnig

Table 6.5.
Technical characteristics of the EuroDish dish/Stirling system shown in Figure 6.15
Source: Schlaich Bergemann und Partner, Stuttgart

Concentrator diameter: 8.5 m	Reflectivity: 94%
Aperture: 56.6 m ²	Working medium: Helium
Focal distance: 4.5 m	Gas pressure: 20–150 bar
Average concentration ratio: 2500	Receiver-gas temperature: 650°C
Electrical gross capacity: 9 kW	Max. operating wind speed: 65 km/h
Electrical net capacity: 8.4 kW	Survival wind speed: 160 km/h

An opportunity to realize just such a reduction has been announced in the USA, with the 850 MW SES (Stirling Engine System) Solar One and the 750 MW SES Solar Two plants scheduled for construction in San Bernardino County, California.

The former, undergoing certification at time of writing, foresees the installation of around 30,000 solar dish Stirling systems rated at 25 kW each on a site covering more than 33.3 square kilometres (12.86 square miles).

6.3.4 Economics and outlook

Concentrating solar systems use only the direct part of the solar radiation, whereas non-concentrating solar systems such as photovoltaic systems also make use of the diffuse part. Tables 6.6 and 6.7 show that the direct normal irradiation increases with decreasing latitude towards the equator more rapidly than the global horizontal irradiation.

Table 6.6.
Direct normal irradiation and global horizontal irradiation values for various European capitals

	London	Berlin	Paris	Rome	Madrid	Lisbon
Latitude (°N)	51.5	52.5	48.9	41.9	40.5	38.7
Direct normal irradiation (kWh/m ² a)	690	787	842	1565	1593	1769
Global horizontal irradiation (kWh/m ² a)	956	993	1088	1561	1582	1686

Table 6.7.
Values for direct normal irradiation and global irradiation of various regions that are interesting for the installation of solar thermal power plants

	Bari (Italy)	Tabernas (Spain)	Oujda (Morocco)	Cairo (Egypt)	Luxor (Egypt)
Latitude (°N)	41.1	37.1	34.2	30.1	25.4
Direct normal irradiation (kWh/m ² a)	1884	2180	2290	2350	2975
Global horizontal irradiation (kWh/m ² a)	1659	1832	1995	2093	2438

It is true that solar thermal power plants can also be operated in regions with rather low direct irradiation, but the economic viability decreases significantly there. Suitable regions show an annual total direct normal irradiation in the order of 2000 kWh/m²a or above. The most suitable regions can be found in southern Spain, southern Italy, Greece and northern Africa.

Today, at good locations, levelized electricity costs of the order of €0.15/kWh can be realized (see Figure 6.16). Volume production and technical improvements could lower these costs to below €0.10/kWh. Technically, solar thermal electricity can also be transported from northern Africa to central Europe. Given future transport costs of €0.01–0.02/kWh, a significant part of the electricity supply in central Europe could be covered by environmentally friendly solar thermal electricity in the long-term future.

Figure 6.16.
Net electricity production and levelized electricity costs of a 50 MW_{el} parabolic trough power plant for 65 different worldwide locations plotted against the annual direct normal irradiation

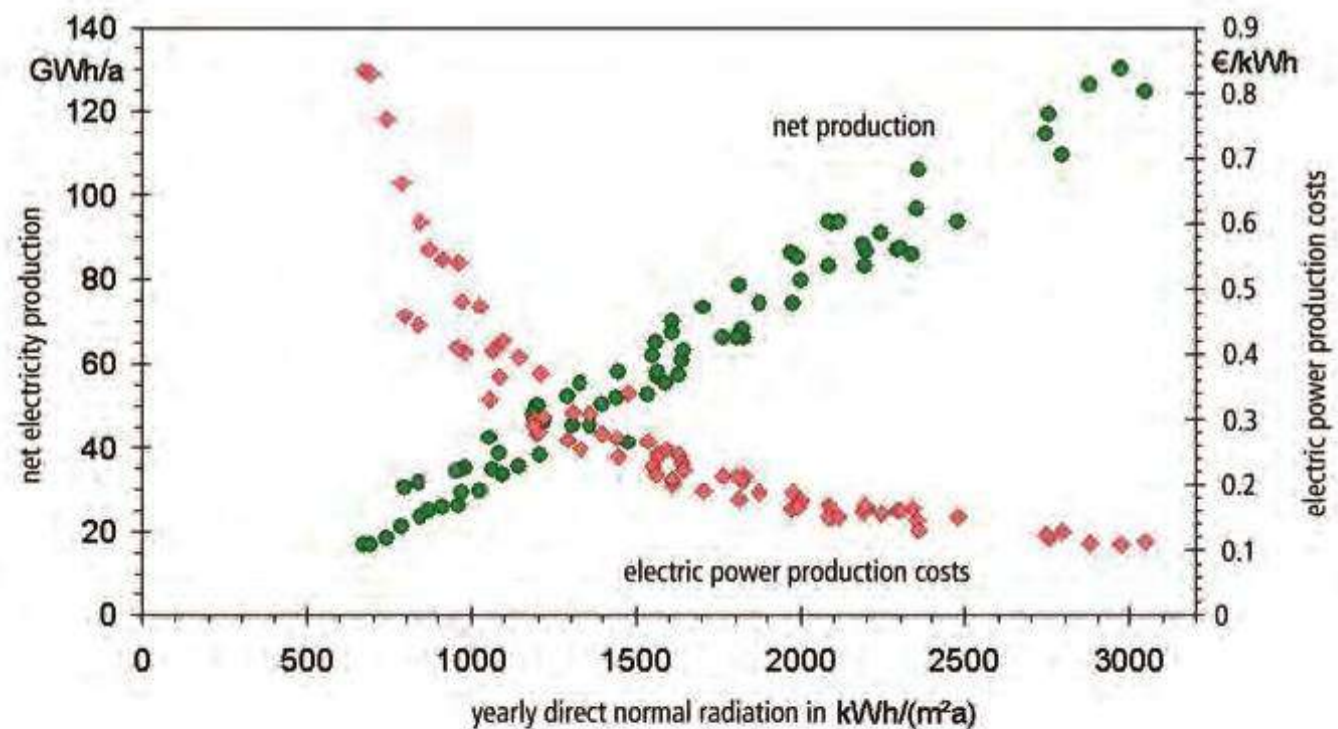

7 Solar heating of open-air swimming pools

7.1 Introduction

Solar heating of open-air swimming pool water has some decisive advantages over other methods of using solar energy thermally:

- *Temperature level.* The required temperature level is comparatively low, at 18–25°C (64.4–77°F). This permits the use of less expensive polypropylene absorbers.
- *Solar radiation and time of use.* The swimming season coincides with the time of the highest solar radiation. Commonly at latitudes in central Europe open-air pools are operated from the beginning or middle of May until the middle of September. During this period approximately 65–75% of the annual solar radiation occurs. At lower latitudes, the swimming season can be longer. Because of higher air temperatures the need for swimming pool heating may decrease, but with a smaller collector high efficiencies can be reached.
- *Simple system design.* The pool water flows directly through the absorber, powered by the filter pump. The storage tanks normally required for solar energy systems are not required, as the pool itself takes over this function.

Solar heating for open-air swimming pools has been used for several decades now, and is a well-established technology. However, this does not mean that this application of solar thermal energy has reached its limits yet.

According to statistics in *Sun in Action II*⁴³, the updated overview of European solar heating markets by the European Solar Trade Industry Federation (ESTIF), about 3000–4000 m² (32,292–43,056 ft²) of unglazed collectors were erected yearly in the 1990s. The estimated production and sales for 2000 and 2001 were 10,000 m² (107,639 ft²) yearly.

If we look at the developments over recent years, heating of the pool is too costly for most swimming pool owners. Existing older conventional heating systems are, however, often replaced either by absorber systems, or the owners do without heating altogether.

If conventional fuels are used for heating pools and spas they are most likely to use natural gas; however, some heat-pump pool heaters have emerged in the US markets.

This chapter describes in detail the components, planning, installation and economics of swimming pool absorber systems. The emphasis is on the solar heating of swimming pools (open-air pools in the private area with pool sizes of up to 250 m² (2691 ft²)) and public open-air pools (local authority or privately operated). We shall also discuss combination options with systems for domestic water heating and for room heating support. The various options for making use of solar thermal energy in the indoor pool area were described in more detail in Chapter 5.

7.2 Components

7.2.1 Absorbers

Solar open-air pool heating uses absorbers to collect the energy (Figures 7.1 and 7.2). The collector design is characterized by the lack of either a transparent cover and housing or thermal insulation. This simple construction is possible as the systems operate with low-temperature differences between the absorber and the surroundings and with relatively uniform return temperatures (10–18°C; 50–64.4°F).

The swimming pool absorber is generally made from plastic, utilizing a specially stabilized polypropylene polymer as the plastic extrusion. As an alternative, some



Figure 7.1.
Solar absorber in an open-air pool.
Source: Lange GmbH, Telgte



Figure 7.2.
Swimming pool absorber system for a private pool

manufacturers use EPDM extrusion, as it is more flexible and can be fixed directly to roof shingles. Pool absorbers are generally drained in the winter to prevent frost damage to the absorbers and piping.

Because of the risk of corrosion of thermal collectors with copper absorbers, these can be operated in solar systems for swimming pool heating only if a separate solar loop is installed (that is, an indirect system).

7.2.1.1 EFFICIENCY AND YIELD

The use of unglazed and uninsulated absorbers for solar open-air pool water heating has some advantages, owing to the special operating conditions.

In the typical operating range, with a temperature difference, $\Delta\theta$, between the outside temperature and the mean absorber temperature of 0–20 K, absorbers often operate with a higher efficiency than glazed collectors. This is because the optical losses (normally about 20% with respect to the amount of solar radiation) through a transparent cover do not arise, and the thermal losses are not so significant because of the low temperature difference. These thermal losses increase with operating temperatures, but this rarely occurs because of the moderate absorber temperatures found under normal operating conditions. The wind speed is the decisive factor that causes losses and hence has a negative effect on the efficiency of the absorber (Figure 7.3).

7.2.1.2 DESIGNS

Apart from a few special designs, plastic absorbers can be subdivided into two groups:

- tube absorbers (small tube absorbers)
- flat absorbers.

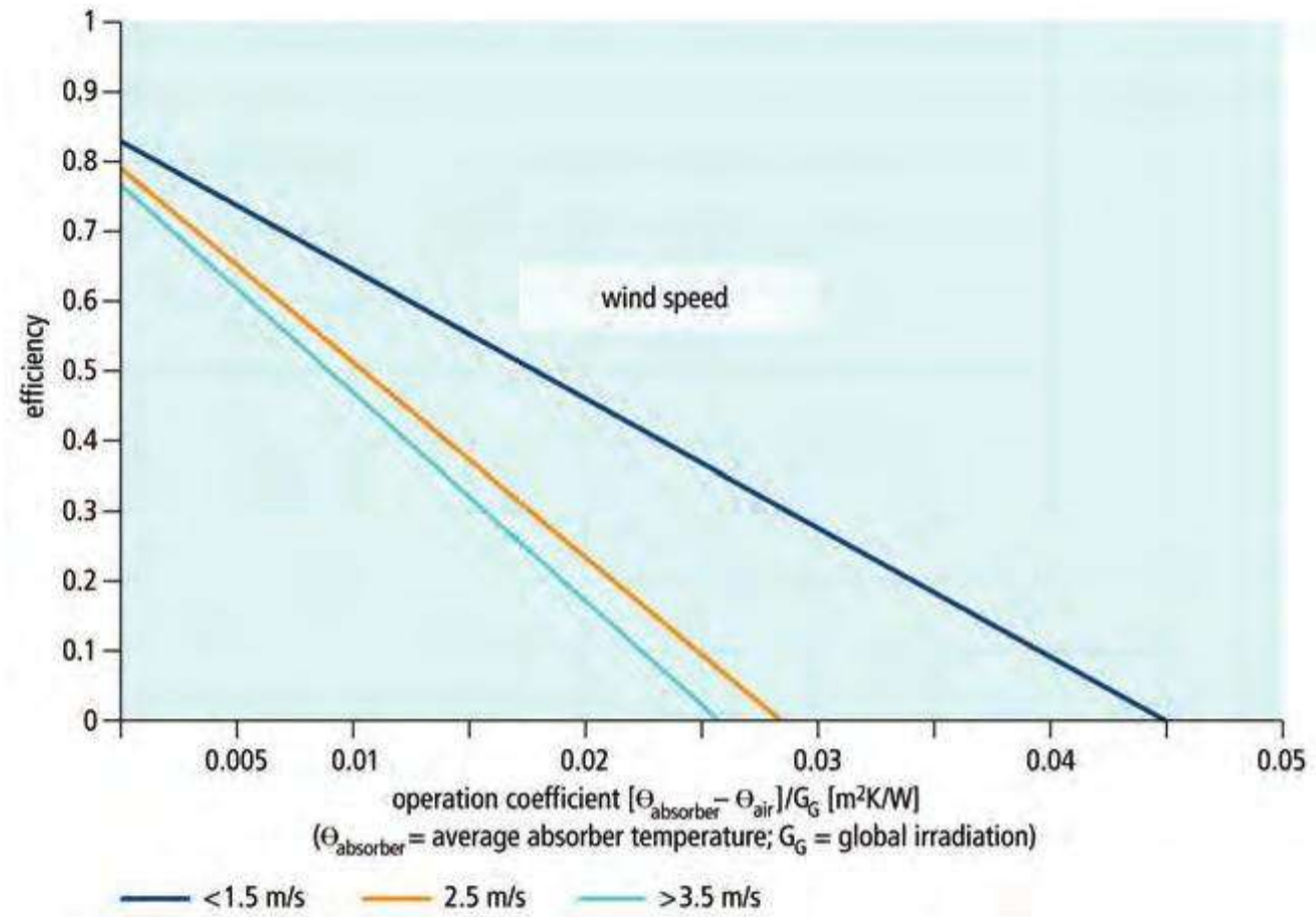

Figure 7.3.
Characteristic curve as a function of
wind speed

The *tube absorber* (Figure 7.4) is the simplest design. A number of smooth or ribbed tubes (small tubes) are arranged in parallel and, according to the design, are connected together either with intermediate webs or by retainers at a given spacing. Absorber lengths of up to 100 m (328 ft) can be achieved, and obstructions such as chimneys or rooflights can easily be circumvented.



Figure 7.4.
Chimney bypass with an EPDM tube
absorber. Source: DGS

In the case of *flat absorbers*, sometimes also called *plate* or *cushion absorbers*, the channels are linked together structurally. This produces plates of different dimensions with a smooth surface. This has the advantage that there are no grooves in which dirt or leaves can accumulate and solidify. The self-cleaning effect during rain is also better.

The influence of the design form on the conversion factor with different inclination angles can be measured, but it is minimal. Variations of the angle of incidence lead to only small differences in the conversion factor for flat collectors. They lead to larger variations with ribbed tube absorbers than with normal tube absorbers.

All absorbers are very easy to handle (see also Chapter 5 on installation): thus for example all common types can be walked on.

Figures 7.5 and 7.6 show respectively a summary of the absorbers available on the market, and the different methods of connecting the absorber to the collection and distribution pipes.

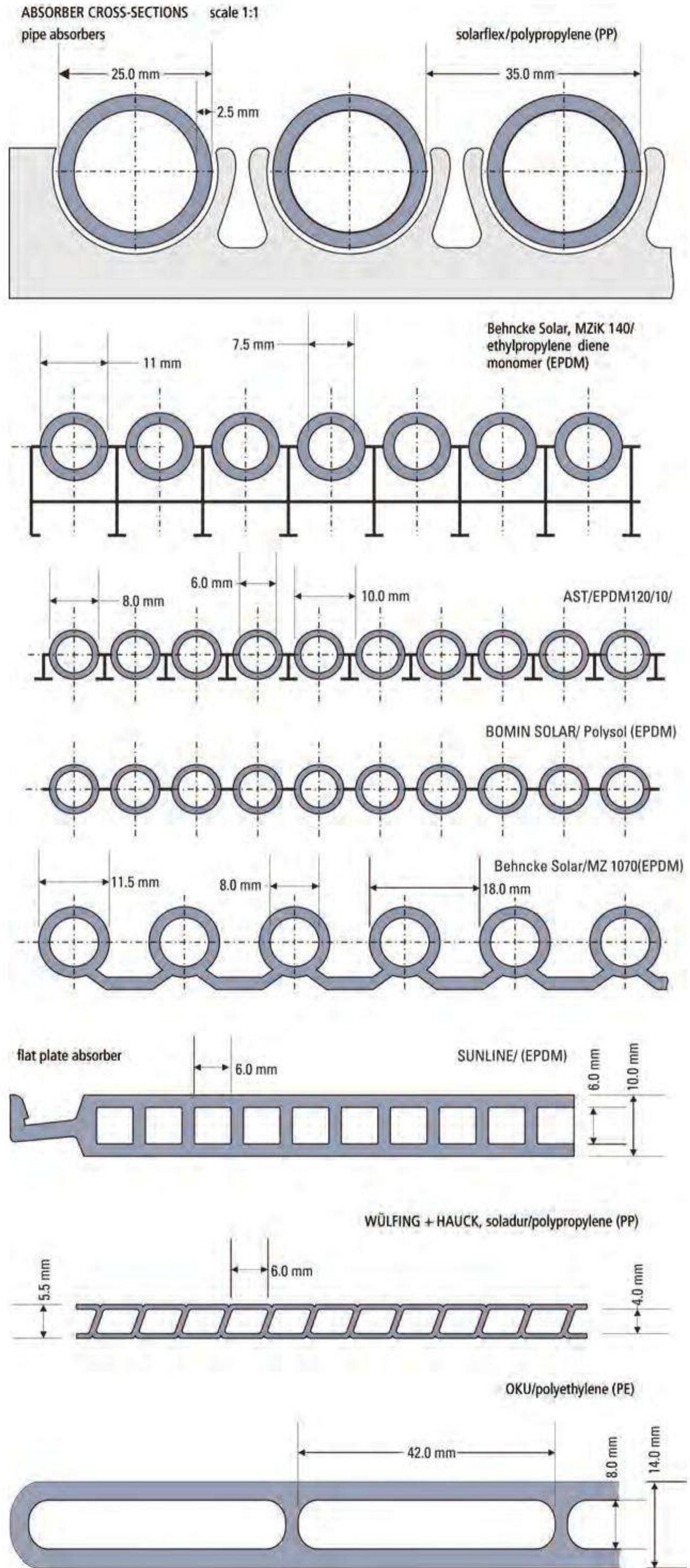

Figure 7.5. Different designs of absorber in cross-section

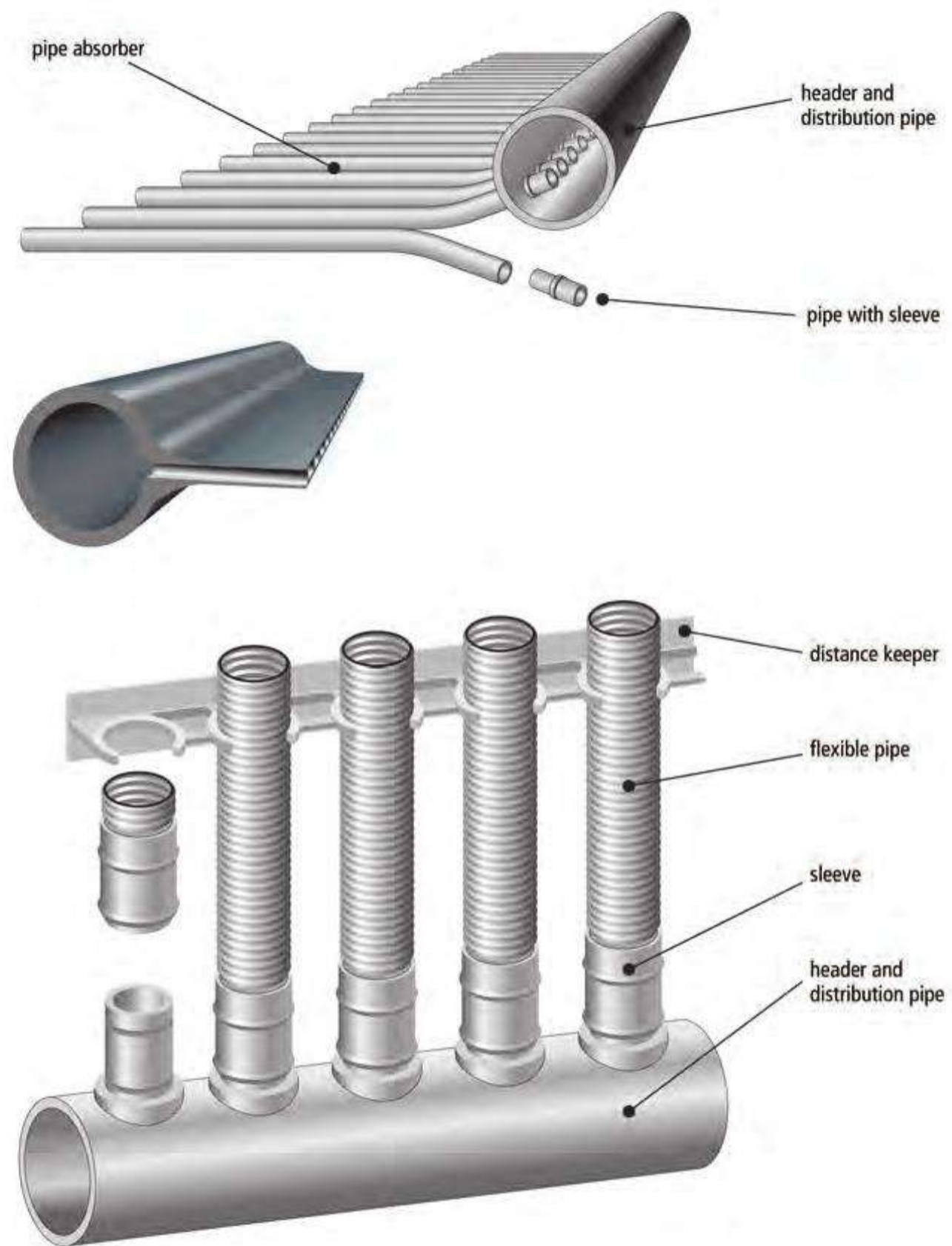

Figure 7.6.
Different methods of connecting the
absorber to the collecting/distributing
pipes

7.2.1.3 PRESSURE LOSS

It is important to consider the pressure loss of the absorber during planning. As the pressure loss for the whole system defines the pumping power, the objective of the designer here should be to achieve the lowest possible system power requirement with the highest possible thermal yield.

In the following we shall therefore discuss briefly the very different pressure losses of the individual absorbers. In general it is true that the maximum permissible excess operating pressure is quite low (0.5–1.5 bar; 7.3–21.7 psi). Only the finned tube absorber has a higher value (3.0 bar; 43.5 psi). The tube cross-section or diameter has the greatest influence on the pressure loss. When using absorbers with small tube diameters, lower maximum lengths are possible than for absorbers with large diameters. This must be taken into account during system planning.

7.2.2 Piping and header pipes

In principle the same components as used in the solar circuit for solar heating can be used for open-air swimming pool construction. Copper or steel pipes cannot be used here because of the risk of corrosion; plastic pipes are the only ones that can be used.

The header pipes are generally made especially for the particular absorber type and are offered by the manufacturer together with it. Sometimes they are actually integrated directly in the absorber.

According to the system, end-stoppers, sleeves, socket ends and pipe connections are usually offered together with the collector and distributor pipes, which can be fixed by gluing, by welding or – as shown in Figure 7.7 – with clamps. In the case of long straight pipelines very high temperature-related length changes must be taken

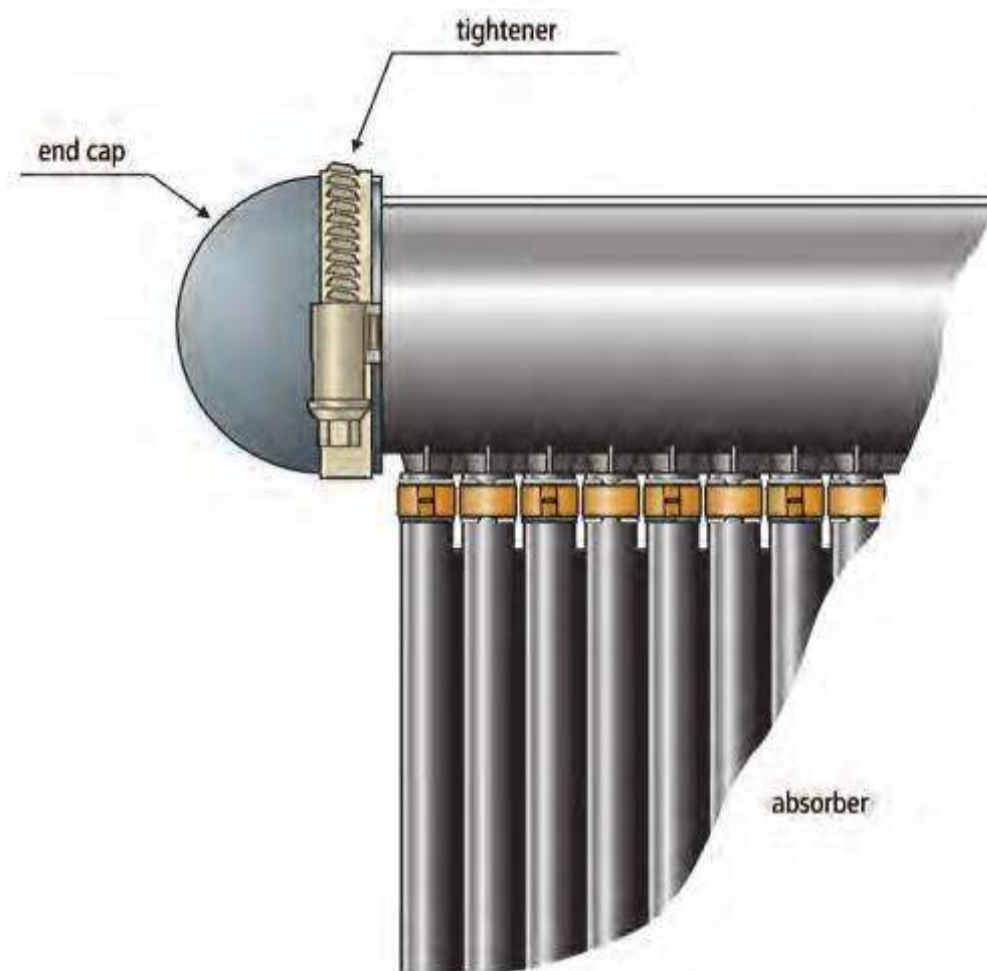

Figure 7.7.
End cap of a collector pipe fixed with
clamps

into account for plastics (coefficient of thermal expansion up to 0.2 mm/mK). Appropriate expansion bends must be installed with anchor clamps, which are fixed so that they can slide in the direction of the pipeline (see also section 7.5.2.2).

7.2.3 Materials

Solar absorbers are exclusively made from plastic. They can be hard and rigid or soft and flexible according to the plastic mixture. The use of plastic permits operation of the solar system with chlorinated swimming pool water. It is, however, necessary to consider the chlorine content. A high dose (from about 5 mg/l) can damage the absorber. The exact limits at which damage can occur depend on the composition of the plastic.

Plastics are also used for pipelines. These are made from rigid materials, however. The following plastics are primarily the ones that can be used:

- EPDM (ethyl propylene diene monomer)
- PP (polypropylene)
- PE (polyethylene)
- ABS (acrylnitrile butadiene styrene copolymer)
- PVC (polyvinyl chloride – hard or soft).

Because of their good properties, two absorber materials are market leaders in spite of their higher costs: EPDM and PP. Table 7.1 gives a summary of the typical properties of the designated materials for absorbers and pipelines. Both require specific formulations to avoid degradation in sunlight.

7.2.4 Pumps, heat exchangers and other components

7.2.4.1 PUMPS

The materials used for pumps also have to fulfil the requirements for corrosion protection. Because it is normally not possible to use pumps without metal, corrosion-resistant materials should be used. The impeller, for example, is usually made from cast bronze, and the shaft from chrome nickel steel. The housing usually consists of grey cast iron, but plastics may also be used. Some manufacturers offer swimming pool pumps made completely from plastic, such as glass-fibre-reinforced PP or POM (polyoxymethaline). Pumps can also be obtained on the market in which the pump shaft does not come into contact with the swimming pool water owing to the design. If the capacity of the existing filter pump is not sufficient to pump the swimming pool water through the additional absorber system, one or more supplementary pumps

Table 7.1.
Properties of plastics used as
absorber or pipe materials

Material	Properties	Deployment temperatures	Lifetime	Deployment
EPDM	<ul style="list-style-type: none"> - artificial rubber - Flexible, also frost resistant when filled with water 	- 50°C to 150°C	> 30 years, manufacturer's guarantee often 10 years	Absorber
PP	<ul style="list-style-type: none"> - Polyolefine - Polymer from Propylene - Pipes weldable - Frost resistant (when not filled with water) 	- 30°C to 120°C	> 20 to 30 years, manufacturer's guarantee often 10 years	Absorber, piping
HDPE	<ul style="list-style-type: none"> - High density polyethylene - Weldable - Mostly pipes, rigid - UV resistant through soot - Frost resistant (when not filled with water) 	- 30°C to 110°C	> 30 years	Piping, absorbers
Soft PVC	<ul style="list-style-type: none"> - Can be glued - Deteriorates when softeners escape 	- 20°C to 65°C	Strongly dependent on application	Piping
Hard PVC	<ul style="list-style-type: none"> - Can be glued, UV resistant 	- 5°C to 100°C	> 20 years	Piping
ABS	<ul style="list-style-type: none"> - Polymer 	- 10°C to 80°C	> 20 years	Piping, distribution piping

must be used. Owing to the large volumetric flow in comparison to domestic water solar systems, and the resulting pipe diameters, the pumps are correspondingly dimensioned and have power settings of several kW, or even more in the case of very large systems (see Figure 7.8).



Figure 7.8.
Standard as well as self-priming
pumps in plastic and bronze
(Manufacturer: (left) Herborner;
(middle and right) Büniger and Freese)

7.2.4.2 HEAT EXCHANGERS

Standard solar systems for open-air pool heating have a simple system construction, in which no heat exchanger is necessary. If, however, a second type of heating is required, heat exchangers are necessary. The heat exchanger must naturally meet the same material requirements as on the swimming pool water side. Stainless steel (V4A or St.1.4571) is generally used here. All sorts of heat source, such as heat pumps or gas heating boilers, can be connected and a temperature sensor positioned for control purposes. Certain system configurations (see section 7.3), however, require the use of heat exchangers, which are described in more detail in sections 2.4.4 and 5.4.



Figure 7.9.
Heat exchangers for swimming pool heating made from stainless steel (flat or upright) or titanium (Manufacturer: Büniger and Freese, Achim)

7.2.4.3 OTHER COMPONENTS

According to the system connection, pumps and/or partly motor-controlled valves (Figure 7.10) are necessary for the operation of the system. Plastics are also used here for the valves. Such commercially available fittings for swimming pool systems can be obtained in both PVC and PE or similar materials. As the flow is regulated by motor-controlled valves, some manufacturers of control equipment also offer such fittings for swimming pool system operation. In addition, non-return valves, shut-off valves or slide valves and ventilators are required. These fittings are also standard accessories for swimming pool technology, and are available in correspondingly appropriate materials.



Figure 7.10.
Motor-controlled two-way valve and hand-operated three-way valve manufactured from PVC (Manufacturer: Akatherm FIP GmbH, Mannheim)

7.2.5 Controllers

A swimming pool absorber system uses the well-known principle of *temperature difference control*. However, the temperature differences that lead to a switching procedure are significantly smaller than in the case of domestic water heating systems, for example. Thus the starting of the solar pump or the positioning of the three-way valve takes place at 2–4 K, whereas at 0.5–1 K the pump is switched off again, or the three-way valve is switched over.

When the pool temperature exceeds a given value the solar system is switched off again. This value can, for example, be approximately 28°C (82.4°F). The maximum temperature should be carefully selected. On the one hand a reduced refreshing effect for the swimmers at higher temperatures plays a role; on the other hand the selected maximum temperature should not be too low, as the pool can act as ‘buffer storage’ for less sunny days.

The important thing for any form of control is the correct positioning of the temperature sensors. For switching on the absorber circuit pump, the absorber temperature is compared with the pool temperature. However, the pool temperature is not acquired within the pool itself but in the filter circuit. For the most accurate control of the system the on and off signals for the solar systems are separated from one another. This means that the absorber temperature is not used for switching off; instead the feed temperature is compared with the pool temperature. Accurate sensor elements increase the thermal yield of the solar system. As a rule Pt1000 sensors are used. It is, however, also important that the sensors are compared in pairs. It is of secondary importance whether the absolute temperature is accurately displayed.

It has also been found to be useful, especially for large solar systems, to acquire the absorber temperature not by means of clip-on or immersed sensors, but rather by means of a separate non-filled reference absorber section. In this way the effect of the relevant variables of radiation, air temperature and wind is transferred to the output with a very low control delay time.

Controllers for large swimming pool absorber systems can usually also record other variables such as irradiated power and volumetric flow, so that balancing and determination of the efficiency of the solar system can take place. There are also controllers that can operate different pools with different temperature levels. A paddling pool for small children has a much higher set temperature than a swimming or diving pool. If there is low irradiated power and hence available heat from the absorber systems, this can be supplied for example directly to the children's pool, as the thermal output from the absorber is sufficient for this but not for the larger pools.

Figure 7.10 shows a standard control scheme for solar open-air pool heating. Correct positioning and suitable sensors play a decisive role here. Some controllers are also able to control the auxiliary heating. In order to use energy rationally it is particularly important to consider the desired maximum temperature in the case of auxiliary heating. If one chooses a high target temperature the losses increase and hence the energy consumption also increases. If the temperature is raised, for example, from 25°C (77°F) to 25.5°C (77.9°F) the energy consumption increases by up to 10%.

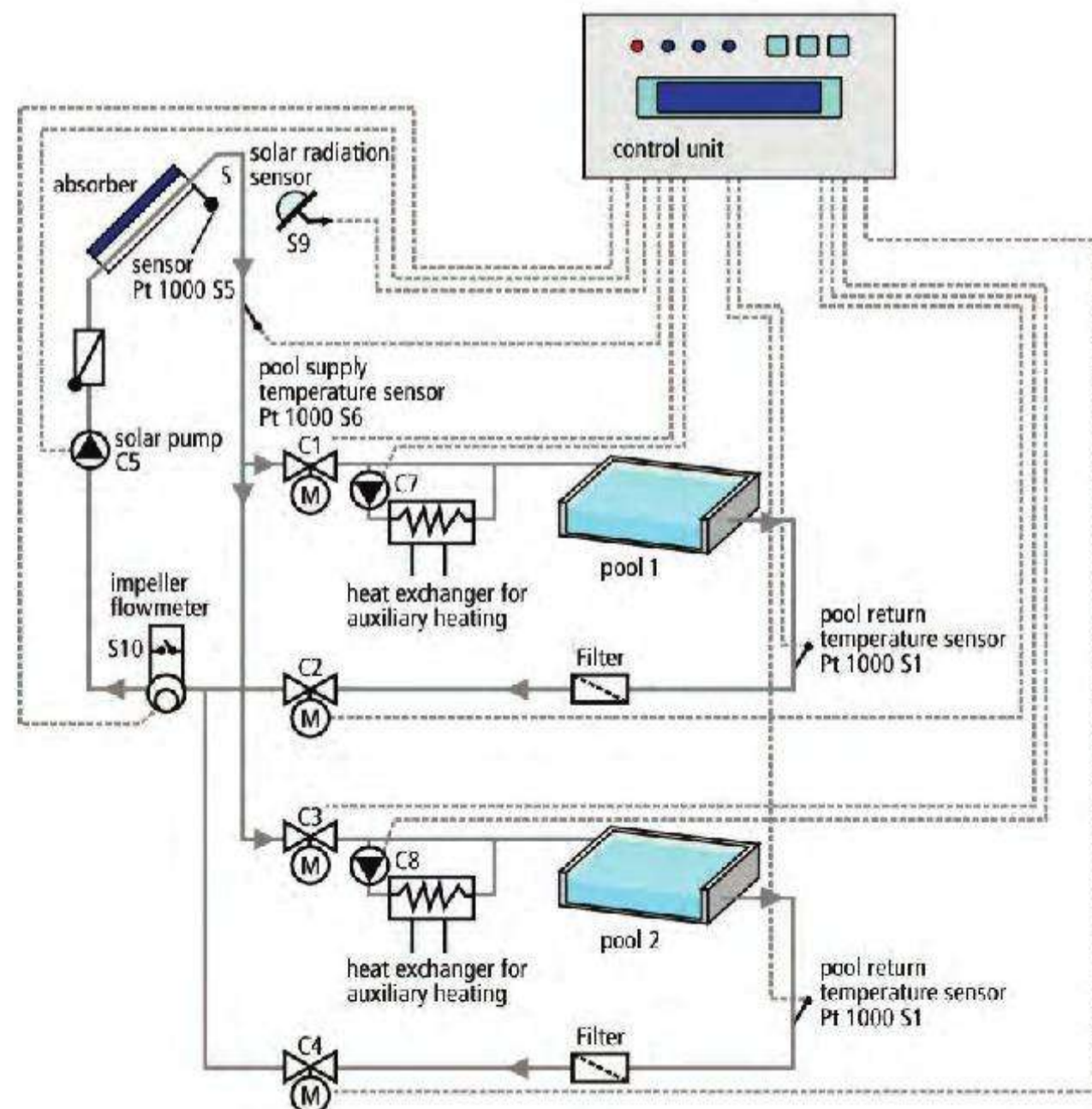

Figure 7.10.
Example of a control scheme for a solar
open-air pool heating system

NOCTURNAL COOLING

In hot and sunny weather, normal solar radiation striking the surface area of the pool may result in pool temperatures exceeding the point at which the pool is refreshing. A simple switch can be employed to simply reverse the sensors and trick the controller into engaging the pump and circulating pool water through the collectors. If a clear sky is present, thermal radiation from the pool water can effectively reduce water temperatures and ensure a refreshing pool. In large pools where swimming competition requires temperatures within a several degree threshold, this feature can be very useful for outdoor competition.

7.2.6 Covering of the swimming pool

The heat losses from a swimming pool occur mainly from the surface of the water through evaporation, but also through convection and radiation (see also Figure 7.16). To prevent overnight reductions in the pool temperature a cover over the water surface with a suitable thermal insulating effect is recommended. This prevents up to 100% of the overnight evaporation of the pool water from taking place, and the losses through radiation and convection are significantly reduced too.

A cover is particularly efficient in temperate climates, if the pool water is to be held at a high temperature ($> 25^{\circ}\text{C}$; 77°F) or if the pool is in an unprotected position. Here it is possible to save between 30% and 50% of the energy according to the location and position of the pool, or the temperature can be held at a higher level. Because of the considerable extra costs for covering the large pool surfaces in municipal open-air pools these covers are usually not installed.

In the case of private swimming pools, simple and cheap covers can always be installed. The absorber surface can be kept smaller because of the savings due to the covering, and the total investment costs can thus be reduced in spite of the extra costs for the cover. Just like the absorber, the covers should be UV- and temperature-resistant. They also are made of plastics such as, for example, closed cell PE foam, PE bubble-foils or PVC cellular profiles (Figure 7.11). The heat can be significantly better maintained in the pool with PE foam covers than with PVC profiles.

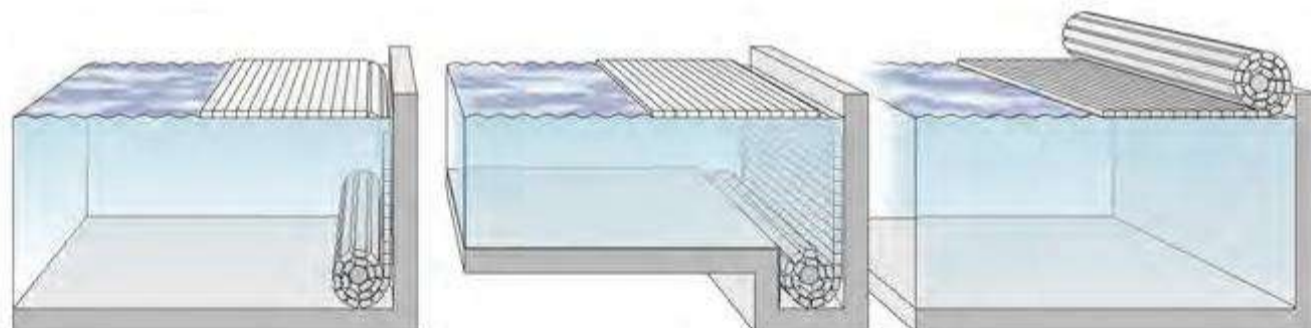

Figure 7.11.
Different covering variants for swimming
pools to reduce heat losses

7.3 Systems

7.3.1 Solar private open-air pool heating

In the case of private swimming pools the pool surface is seldom larger than 100 m^2 (1076 ft^2). Commonly only simple filter circuits are installed here. Conventional auxiliary heating systems are being installed less and less. As for domestic water heating systems, solar systems are now being offered as complete packages with all necessary components. The absorber surface area is dimensioned according to the size of the pool (see planning section) and is thereby offered in different sizes. There are several methods of implementing the hydraulic circuit and the operation of the absorber circuit. The two most sensible and most frequently used systems are described in detail in the following sections.

7.3.1.1 SYSTEMS WITH THREE-WAY VALVES

The absorber circuit is integrated into the existing filter circuit with a three-way valve (Figure 7.12). This means that the filter pump must be suitably dimensioned in order to overcome the additional pressure loss in the absorber circuit. As a rule this is the case in private swimming pools. It depends strongly on the height difference between the pool surface and the absorber. If this is greater than about 5 m (16.4 ft), an additional absorber circuit pump is normally required (see section 7.3.1.2).

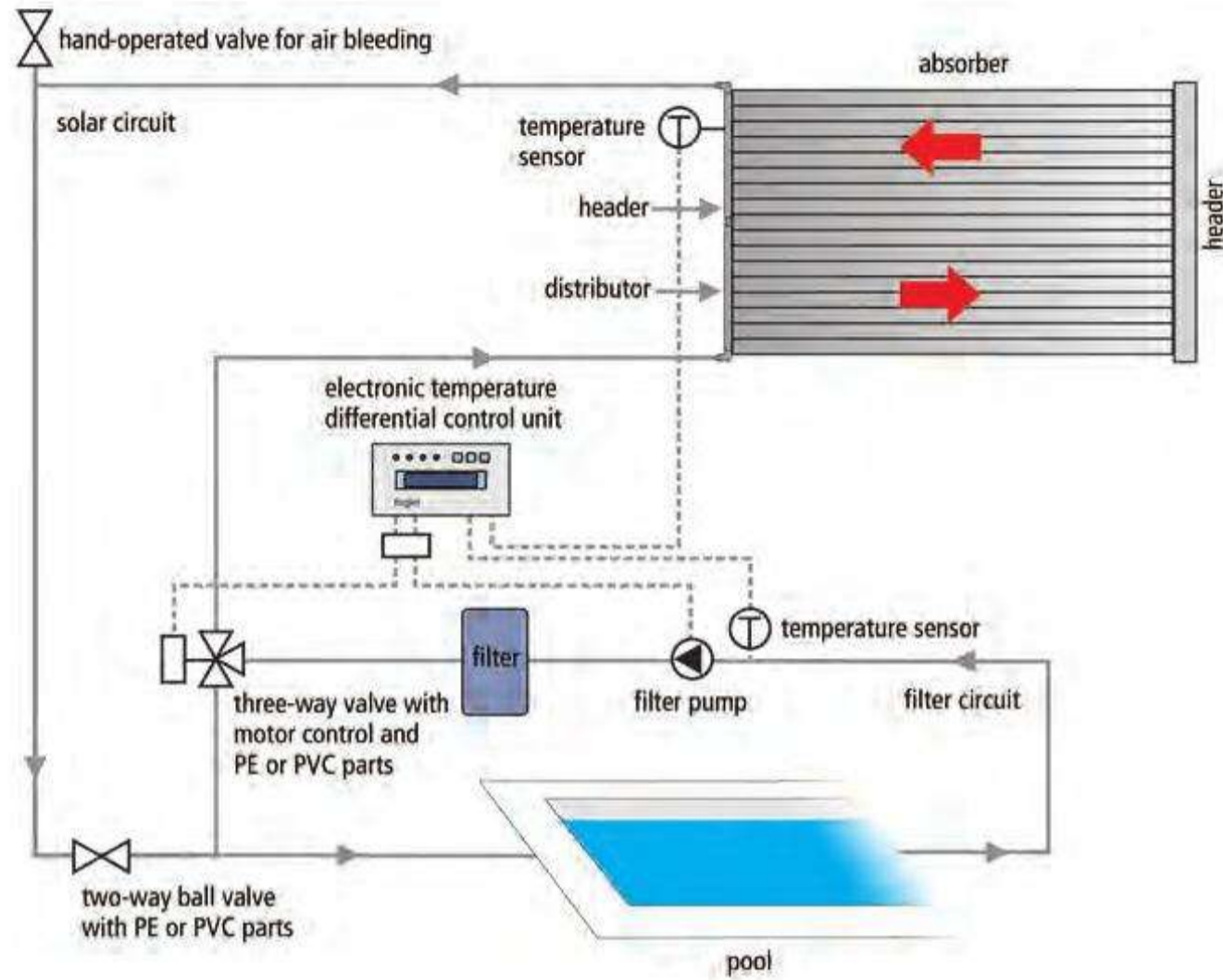

Figure 7.12. Circuit diagram of absorber system with three-way valve

If a suitable temperature difference (2–4 K) exists between the absorber and the pool water, the solar controller starts the pump operation. The motor-controlled three-way valve is set so that the water flows through the absorber, heats up, and is then led back to the pool.

There are even simpler solutions in which the three-way valve is operated manually instead of by the controller. However, these are rarely used.

7.3.1.2 SYSTEMS WITH ADDITIONAL ABSORBER CIRCUIT PUMP

In these systems an additional pump operates the absorber circuit. In the conditions described above, this is switched on in addition to the filter pump. A non-return valve should be installed in the feed to the absorber circuit to prevent the absorber field from running empty after switching off the pump. This can be operated electrically or pneumatically. In such a case a non-return valve should also be installed in the filter circuit to prevent incorrect flows (Figure 7.13).

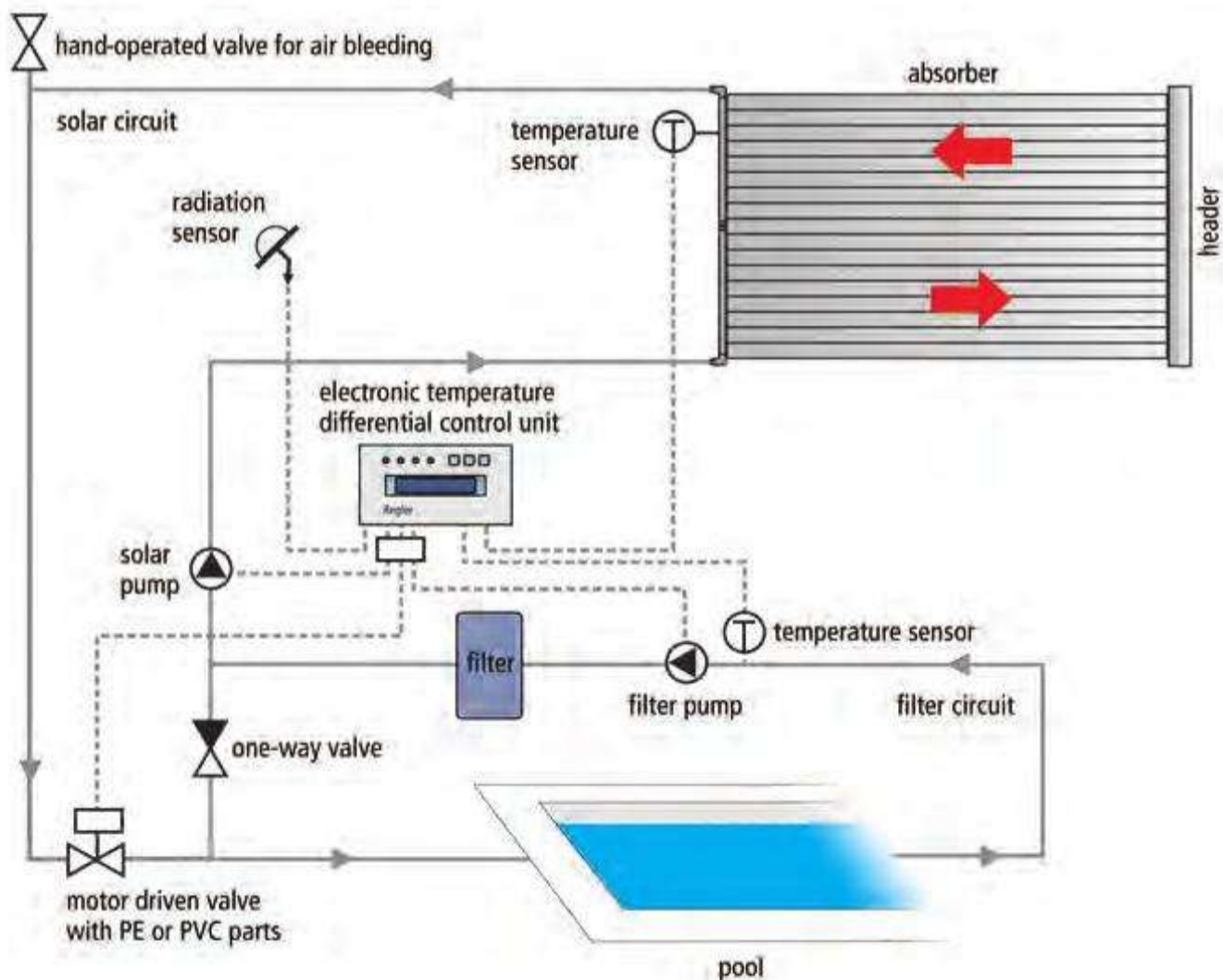

Figure 7.13. Circuit diagram of absorber system with additional solar pump

In a variant without a non-return valve, a set of fans or a ventilation fitting should be installed. If the absorber runs empty when the pump is stationary, a vacuum can occur, which would damage the absorber. A simple ventilating device allows air to flow into the absorber. When the pump is switched on, the air in the absorber is forced out through the absorber and filter circuit into the pool. A ventilating device ensures that the air can immediately escape again from the absorber when the pump is switched on.

In a system with an additional absorber circuit pump there is also an alternative operating mode. If the pool filter circuit is not permanently operated, the absorber circuit can be connected independently of the filter circuit. The pool water is removed in front of the filter system and pumped through the absorber by the absorber circuit pump. For this purpose the absorber circuit pump should have a fine filter connected upstream.

7.3.1.3 INTEGRATION OF AUXILIARY HEATING

Information on the integration of an auxiliary heating system can be found in the corresponding section for public open-air pools. This also applies to private swimming pools.

7.3.2 Solar heating of public open-air swimming pools

A further application for solar open-air pool heating is that of public pools, which are mostly operated by local authorities, although some are privately operated. Here, according to the type of pool complex, one or more pools are heated by the absorber system. How many, and which pools are supplied with solar heat, depends on the system configuration and the surface available for installation of the absorbers. In large open-air pools an absorber surface area of several hundred square metres can easily be required.

7.3.2.1 HYDRAULIC CIRCUIT

Solar circuits in public open-air pools are normally operated with a separate solar circuit or absorber circuit pump. The hydraulic construction is much more complex than for private swimming pools because of the hygiene requirements.

A system in a large open-air pool functions according to the following principle. The waste water is led from the pool into a central water storage tank. This tank acts as a 'water-level display' for the whole swimming pool water circuit. Evaporated water is replaced here by fresh water. The water is pumped through the filter from the water tank. One or (according to the design of the filter system) several parallel-connected filter pumps are used for this. After this the water is returned to the pool via the water treatment system.

In front of the water treatment system, the absorber field is connected to the circuit in a bypass system. The solar loop pump diverts part of the volumetric flow and pumps it through the absorber field. The size of the partial volumetric flow depends on the size of the absorber field. The solar-heated water is led to the main flow again after the diversion and finally arrives back in the pool.

A motorized valve should be installed in the absorber circuit feed line and a non-return valve after the solar pump. These two fittings prevent the absorber field from running empty when the system is not in operation.

Before the water reaches the pool the hygiene parameters are set. Chlorine and chemicals are introduced to regulate the pH value as necessary. The chlorine injection point should always be integrated behind the absorber field diverter, as the chlorine concentration in the absorber circuit must not exceed 0.6 mg/l. If there is a surge of chlorine (under certain circumstances up to 10 mg/l) the absorber may be damaged.

OTHER CIRCUIT VARIANTS

The hydraulic circuit described above is the most simple and economic. It does, however, mean that all pools must be operated via the same filter system.

If each pool of an open-air complex has its own filter circuit, the absorber system must be integrated in other ways. One option is to connect the absorber field hydraulically to several filter circuits. However, a partial flow must always be

diverted from one filter circuit and heated by the absorber system. In this way each pool can be solar-heated successively. For example, at first the swimming pool can be heated, and if additional solar heat is still available this can then be provided to the diving pool.

Other arrangements of the hydraulic circuit allow the supply of the solar-heated water to only one, several or all pools according to the current thermal output of the absorber unit.

When realizing such a circuit, the position of the pools and their filter circuits as well as their distance from the absorber field must be considered for both hydraulic and financial reasons.

7.3.2.2 CONNECTING THE ABSORBER FIELD

With solar-heated open-air pools there is often the difficulty that the absorber field has to be installed on several roof areas. In addition, it is rarely possible for each absorber field to be the same size, and also the pipeline lengths are all different. A circuit conforming to the Tichelmann connection (also called Z-connection) is worth striving for, but is usually not feasible. It is therefore even more important for all the absorber fields to have a uniform flow through them. This entails careful arrangement of the pipelines and absorber field pumps. Ball valves should be installed at suitable points to guarantee simple emptying and filling of the absorber fields.

7.3.2.3 HEAT RECOVERY FROM THE REVERSE FLOW FILTER WATER

The filter system must be cleaned at regular intervals, or the filter itself may have to be cleaned after contamination. This is done by a reverse flow of fresh water. The water flushed through the filter must be drained to the sewer, which means that heat is inevitably lost. The fresh water that replaces the water drained into the sewer can be preheated via a heat exchanger. Coaxial heat exchangers with automatically circulating cleaning pellets have proved themselves to be useful for this.

As for other applications, the economics of heat recovery from the reverse flow filter water must be carefully considered. As a rule this is worthwhile mainly for pool temperatures over 23°C (73.4°F). Installations carried out within the scope of a complete restoration of the pipeline system and a long swimming season can also improve the economic viability.

7.3.2.4 INTEGRATION OF AUXILIARY HEATING

Conventionally operated auxiliary heating is necessary if the pool water has to be maintained at a constant temperature. Some open-air pools like to offer their visitors warm swimming pool water independently of the sunshine, which requires auxiliary heating when the solar radiation is insufficient.

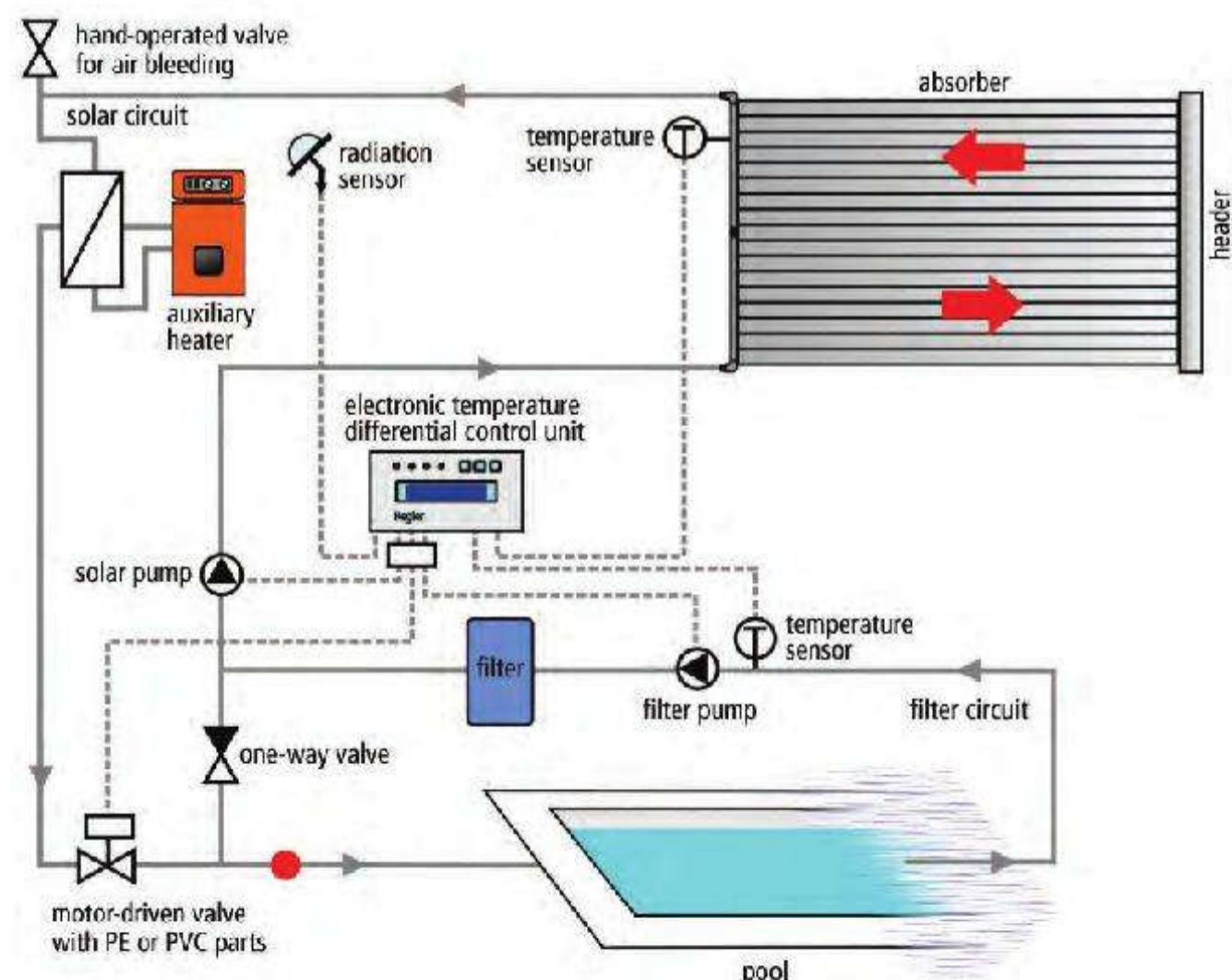

Figure 7.14.
Circuit diagram of large absorber system
with additional heating

Auxiliary heating is operated by means of a conventional system (preferably gas heating) and an additional heat exchanger. In a dual-heated system the auxiliary heating should always follow the solar heating. If the water is not of the required temperature after recirculation to the filter circuit, the auxiliary heating covers the residual heat requirement (Figure 7.14).

7.3.2.5 RATIONAL USE OF ENERGY IN PUBLIC OPEN-AIR BATHS

Much of the total heat requirement is basically determined by the level of fresh water required. The amount of fresh water is very high in most open-air pools: 10–20 m³ (353–706 ft³) per square metre of pool surface per season are typical figures.⁴⁴ Of course, these figures depend on the pool usage. This amount of water has to be heated from the cold water temperature to the pool temperature. In central Europe, this means that about 15–20 kWh of heat is required to heat 1 m³ (35.3 ft³) of fresh water to pool temperature. Whether the amount of fresh water added goes beyond the required level is easily established on the basis of the annual quantity of water consumed, if the water is taken from the public drinking water network.

With old filter technology the required quality can be achieved only by the addition of significantly more fresh water, which in turn must be brought up to the required pool temperature. Together with the increased energy requirement of old pumps and the greater flow resistance of older technology, this can represent half of the energy consumption of an open-air pool complex. So by replacing old equipment a significant part of the energy can also be saved.

7.3.2.6 INTEGRATION INTO EXISTING SWIMMING POOL TECHNOLOGY

The inclusion of a solar system into an existing open-air pool does not normally pose special problems. At a suitable point part of the volumetric flow of the pool water is led through the absorber. According to the design this might even be the whole volumetric flow. As the same technology is used for the pipelines in solar open-air pool heating, the connections do not represent any problems. The most favourable position for the connection of the absorber bypass is after the filter system and before the water treatment station.

The auxiliary heating should always be installed after the return flow of the absorber bypass into the filter circuit so that it can be simply controlled and operated effectively.

If such integration is not possible for structural reasons an alternative must be found. However, it is always necessary to consider the disadvantages, for example connection of the absorber bypass after the chlorine injection point (see section 7.3.2.1).

7.3.3 Combined solar domestic water heating, open-air pool heating and room heating support

A solar system for domestic water heating and for solar room heating support can be sensibly combined with solar open-air pool heating. These systems are designed for heating support in the transition months. In the summer, however, no room heating is required, and hence excess heat is available during this time that can be transferred to the swimming pool water. Additional heat exchangers are required for this, as such solar systems are not operated with plastic absorbers, but rather with glazed flat-plate collectors or evacuated tube collectors.

The system is similar to a solar system with two storage tanks and priority switching, whereby the first tank is a combined tank and the role of the second tank is taken on by the swimming pool (Figure 7.15). Charging of the storage tank has the priority. When this has reached its maximum temperature, or if there is insufficient solar radiation to heat the tank, the system is switched over to the swimming pool in the summer. In the winter the collector surface area, which has been increased for heating support, is completely available to the storage tank. This can both heat the domestic water and be used for room heating support (combined storage tank). With this system it is necessary to take account of the special material requirements for the solar loop/swimming pool water heat exchanger. This must be made from suitable materials (for example stainless steel or possibly special copper alloys) in order to prevent corrosion.

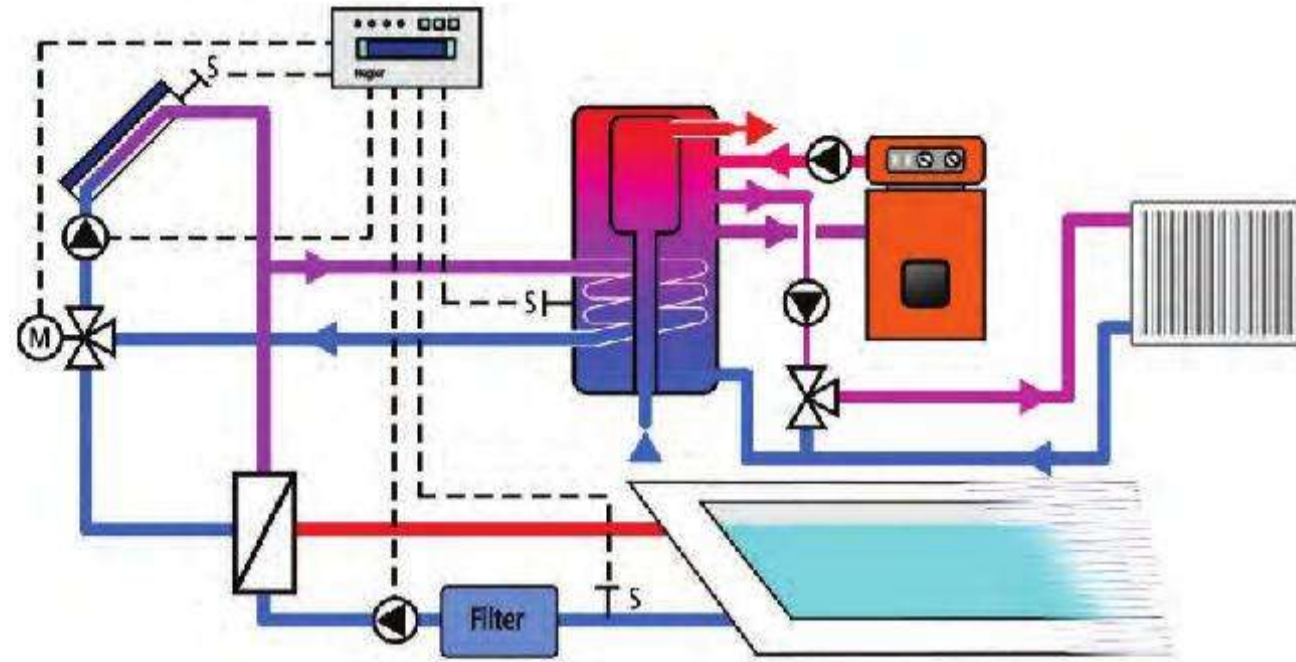

Figure 7.15. Control diagram for a solar system for domestic water heating, room heating support and open-air pool heating

7.4 Planning and dimensioning

7.4.1 Fundamental considerations

As for solar thermal systems for domestic water heating, the prevailing conditions of solar radiation and heat consumption are of great significance in the planning of solar swimming pool heating systems. The heat consumption of a swimming pool is in turn determined by the size of the pool surface area, the depth of the water and the colour of the pool, the desired water temperature, and the ambient meteorological conditions (air temperature and wind speed).

In open-air pools the pool water can be heated to a solar fraction of up to 100% with corresponding system dimensioning. The resulting slight temperature variations in the pool water do not normally affect the visitors' enjoyment, as more visitors come in sunny weather than in periods of poor weather. In such a single-source solar pool water heating system the water volume acts as the storage medium, which cushions the temperature variations. In lengthy periods of poor weather the few regular swimmers must, however, expect and accept a lower pool water temperature compared with a conventionally heated pool.

Table 7.2 gives a summary of the heat gains and losses arising in a swimming pool, together with the variables upon which these depend.

When planning a solar system for pool water heating, the aim must be to balance the thermal losses from the swimming pool against the solar gain as far as possible, so that there is little need for auxiliary heating. However, in the following section we shall also discuss the design of large open-air pools with conventional auxiliary heating.

Table 7.2. Heat gains and losses in a swimming pool, and the influencing variables

Heat gain	Heat loss	Influencing variable
Direct solar radiation into the pool	Evaporation	Pool surface area
Conversion of pump energy	Convection	Pool water temperature
Addition of heat (solar or conventional)	Radiation	Climatic conditions at site
	Surrounding earth	Wind conditions on the pool surface
	Exchange of filter flushing water for fresh water	Number of swimmers in pool
		Groundwater conditions

7.4.2 Approximation formulae for establishing absorber surface area, volumetric flow and pressure loss

7.4.2.1 PRIVATE OPEN-AIR POOLS

The size of the absorber field of the solar system is geared to the size of the pool surface. For private pools the range of possible designs – according to which the average temperature level is to be achieved – is very wide, as here, unlike public open-air pools (see section 7.4.2.2), economic aspects tend to be more in the background.

In principle, the design ratio between absorber surface and swimming pool surface area can be defined as follows:

- Temperate climates: absorber surface area = 0.5–1.0 × the pool surface area.
- Subtropical climates: absorber surface area = 0.3–0.7 × the pool surface area.

Because of the significantly smaller pool surface, private swimming pools should be equipped with relatively cheap covers. If a cover is used, a smaller design ratio can be selected.

For private swimming pools, unlike public open-air pools, the absorber field is often installed on the pitched roof of the house. With a roof pitch $>15^\circ$ the absorber should have an orientation between -45° and $+45^\circ$ to the equator. The less favourable the alignment of the absorber surface, the greater the design ratio that should be selected.

7.4.2.2 MUNICIPAL OPEN-AIR POOLS

Figure 7.16 shows the heat losses from an open-air pool. The evaporation losses on the pool surface represent more than 60% of the total losses. However, these figures depend strongly on the circumstances, such as solar irradiation, pool temperature, air temperature and wind speed.

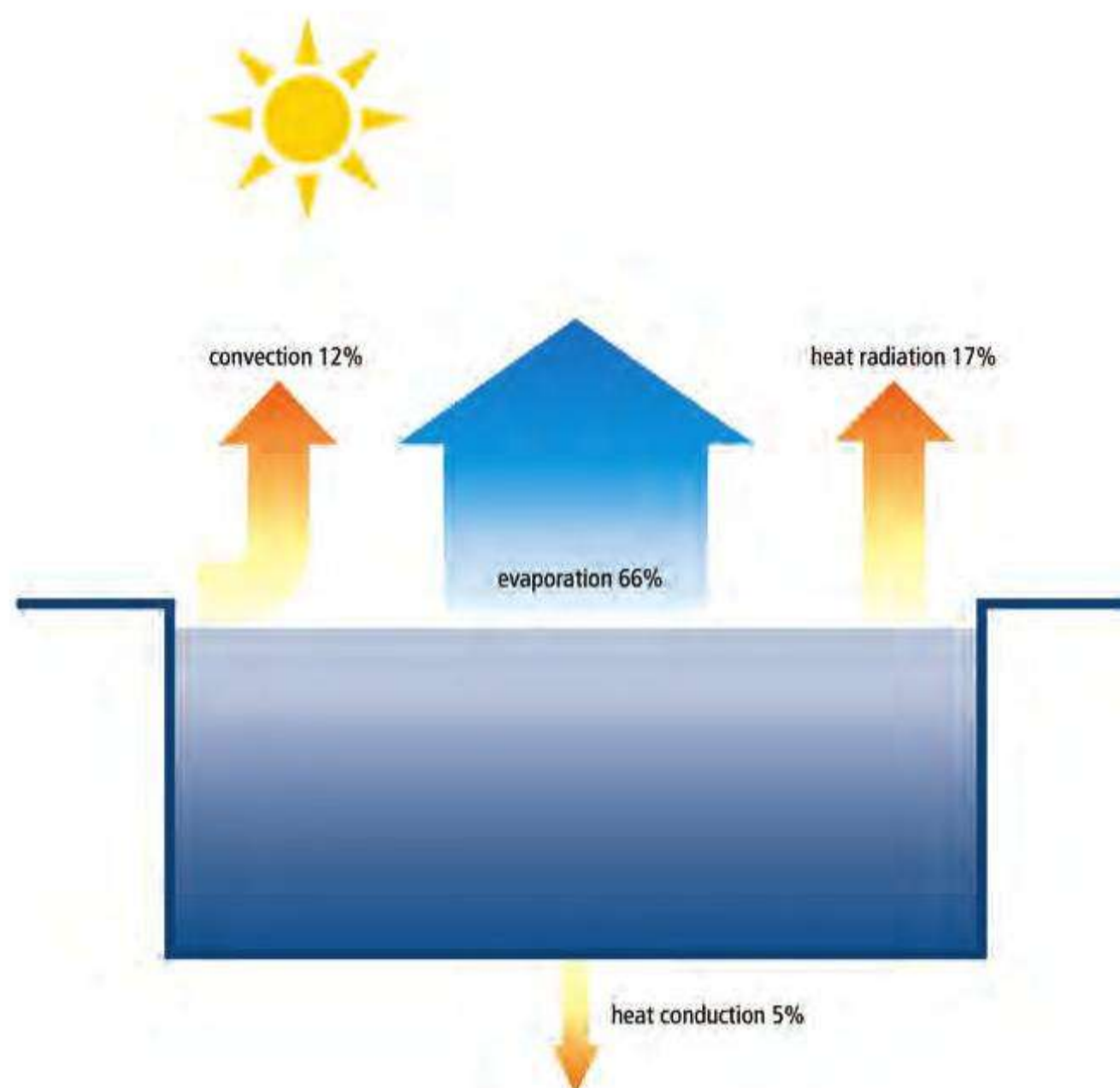

Figure 7.16.
Heat losses from an open-air pool¹⁵

A pool cover can significantly reduce the evaporation losses. However, for public open-air pools with large pool areas this requires very high investment costs, and so such covers are seldom found. In certain circumstances part of the evaporation losses can be compensated for at less expense by increasing the absorber surface area rather than by covering the pool.

Apart from the heat losses over the pool surface, the climatic conditions (radiation, temperature and wind speed) must be taken into account during dimensioning. Given the direct relationship between pool surface area and heat loss (and the heat required to compensate for this), the ratio between absorber surface and pool surface is the decisive criterion for the design of the absorber field.

SINGLE-SOURCE HEATING

Many years of experience of operating solar open-air pool heating have shown that this ratio should be in the following range for temperate climates:

Absorber surface area = 0.5–0.7 × Pool surface area

In subtropical climates, depending on the comfort requirements, 0.3–0.5 × Pool surface area may be used.

With this design, under standard conditions an average pool temperature of 22–23°C (71.6–73.4°F) is established.

The exact design depends on other general conditions. If a high pool temperature is desired, the absorber surface area and hence the design ratio must be increased. In practice it is often the available space for the absorber field that defines the ratio. The alignment of the absorber is not so important for the design. This is largely because the absorber system is normally installed on flat roofs for municipal open-air pools.

DUAL-SOURCE HEATING

If the pool water is maintained at a temp of 21–22°C (69.8–71.6°F) by conventional auxiliary heating, the design ratio of the absorber to the pool surface is selected in a similar way as for single-source heating. The average pool water temperature is significantly higher than for single-source heating. In spite of this, the energy used for auxiliary heating is not reduced to the same extent, as the solar yield increases with larger absorber surface areas. This is due to the increasing losses because of the higher average pool water temperature

Dual-source heating must always be examined critically from the ecological point of view. For a typical design ratio of 0.6, dual-source operation increases the average pool water temperature by 1 K compared with single-source operation. For this comparatively low increase in comfort, a relatively large amount of conventional energy has to be used, which leads to increased operating costs.

CONSIDERATION OF VISITOR BEHAVIOUR

Consideration of the behaviour of the swimmers can help in selecting the system (single-source, dual-source) for heating a pool. Investigations have shown that during periods of poor weather – for example when the air temperature falls below 17°C (62.6°F) – the number of swimmers falls for both types of heating. In a heated open-air pool the number of swimmers may well be several percentage points higher, but in considering the economics of the operation, the pool operator must understand that this high level of comfort involving constant pool water temperatures of, for example, 21°C (69.8°F) is used by only a few swimmers. High visitor numbers are generally achieved only on warm sunny days, on which single-source heating functions well through the solar system.

7.4.2.3 ABSORBER FLOW AND PRESSURE LOSS

Uniform flow through the absorber surface is the most important criterion for high yields, particularly for large absorber fields in public open-air pools.

Furthermore, surface-related volumetric flow is important for efficient heat transfer. The volumetric flow should lie in the range 80–110 l/h per m² of absorber surface. This is a generally recognized value, but the manufacturer's information should always be referred to. With this volumetric flow, and global solar irradiance of 800 W/m², a temperature difference of 6–8 K is established between the feed and return lines.

In principle, the thermal performance of an absorber field increases with increasing volumetric flow. However, from a specific volumetric flow of approximately 80 l/hm² the thermal performance approaches a limiting value. At the same time the required electrical auxiliary energy increases. In order to achieve uniform flow through the absorber surface, the following points should be taken into account:

- $\Delta p_{\text{absorberfield}} \geq 2 \Delta p_{\text{system}}$. The pressure loss along the absorber should be at least double the level of the sum of the pressure losses of the field pipework.
- In order to maintain this, long narrow absorber fields and large distributor pipes with a slow flow speed should be used.
- Pipework conforming to the Tichelmann principle should be striven for, but on its own is not sufficient.
- In the case of several individual fields the installation of throttle valves has proved worthwhile. With variable-area flowmeters the flow through the individual circuits can be monitored and matched.

As a rule, 0.2 bar (2.9 psi) is sufficient to cover pressure loss in the absorber lengths to ensure uniform flow, if the distributor is dimensioned correctly. If the collector mats are relatively short, the pressure loss can be correspondingly increased by series connection or by partial series connections in order to achieve uniform flow.

For good heat transfer between the absorber and pool water the speed should be designed sufficiently high so that the flow in the absorber channel is turbulent. The difference between the flow speeds in the distributor pipe and the absorber channel should, however, not be too great, or flow disturbances such as fringe eddies and suction effects can arise.

If the conditions described above are fulfilled, the optimum flow is achieved with minimum pump energy consumption. The consumption of electrical energy for the pumps should not be more than 2% of the available solar energy.

7.4.2.4 PUMP DESIGN

The design of the absorber circuit pump uses the same calculations as described in Chapter 3 for domestic water heating systems. The total volumetric flow of the system is obtained after determining the necessary absorber surface and taking account of the specific volumetric flow described in section 7.4.2.3. In addition, the pressure loss through the absorber, pipeline and all the fittings in the absorber circuit, and the height difference between the pool surface and the absorber field must be determined. Once the total volumetric flow and pressure loss are established, suitable pumps can be found in the manufacturer's literature for absorber pumps.

7.4.3 Computer-aided system dimensioning

Simulation with a suitable program is also possible for solar open-air pool heating, and in particular for estimating the yield. However, separate calculations have to be performed for the correct design of the absorber field with respect to uniform flow, as the common simulation programs cannot show the flow relationships in the different absorber fields.

Pure swimming pool heating systems (indoor and outdoor) can be simulated with several programs, including T*SOL and the Canadian EnerPool. See Chapter 10.

7.5 Installation

7.5.1 Absorbers

Absorbers can be installed on inclined or flat roofs with different designs. It is also possible to install them at ground level. As, even in temperate climates, the main times of use are in the warmest months where the elevation angles of the sun are greater than 50°, installation on rigging to optimize the yields is not necessary. If an inclined surface is to be used, then an alignment facing the equator in the range -45° to +45° is advantageous.

The installation of the absorber is strongly dependent on the type (tube or flat absorber) and the properties of the background. The structural strength of the roof plays only a minor role here. The absorber itself, when filled, has only a low surface weight of between 8 and 12 kg/m² (1.6 and 2.5 lb/ft²) according to the design. Concrete slabs are used to secure the absorber field against wind forces. For this the surface load can be considerably higher than the absorber field, so that in this case the structural strength of the roof should be checked.

Whenever roof penetrations are created, it is essential that they are closed again afterwards and made weatherproof. Fixings that do not require the roof skin to be penetrated are preferable, such as flat roof installation on concrete slabs as already mentioned.

7.5.1.1 MECHANICAL FIXING OF THE ABSORBER

In many applications the absorber is installed on a flat roof or a slightly inclined roof. Mechanical fixings for the absorber in the form of webbing or steel rails are suitable here (Figure 7.17). The key aspect here is to secure the absorber field against wind forces. In the case of public open-air pools, installation on flat roofs with wind security provided by concrete slabs has been found to be the simplest and cheapest solution.

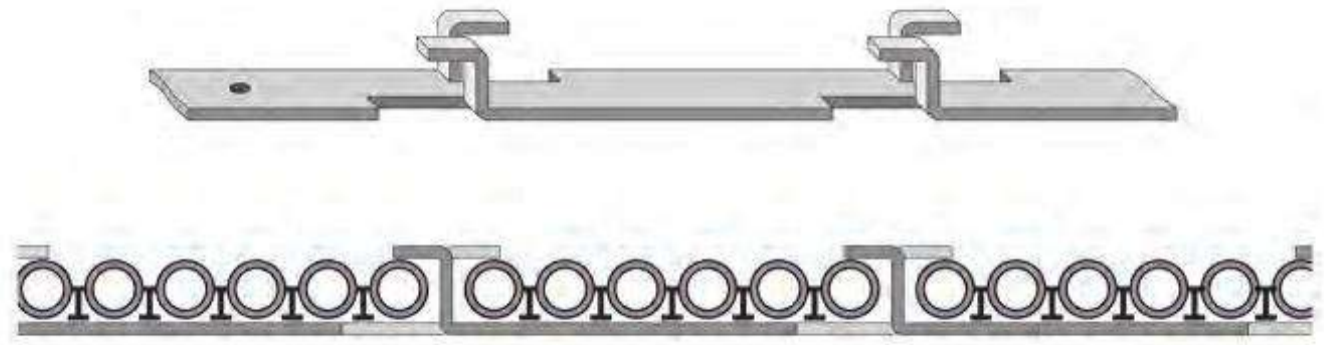

Figure 7.17.
Mounting rails: Behncke Solar System

The concrete slabs must have component protection mats underneath them to protect the roof skin. As shown in Figure 7.18 the installation system can be mounted on the concrete slabs. The absorbers are then fixed between two concrete slabs using aluminium rails or webbing. Webbing has been found to be the cheapest and most versatile system for this. The absorbers are clamped with one upper and one lower webbing belt perpendicular to the direction of flow. The distance from one belt to the next should be no greater than 1.5 m (4.9 ft). At regular intervals (also about 1.5 m) the upper and lower belts should be fixed with UV-resistant cable binders.

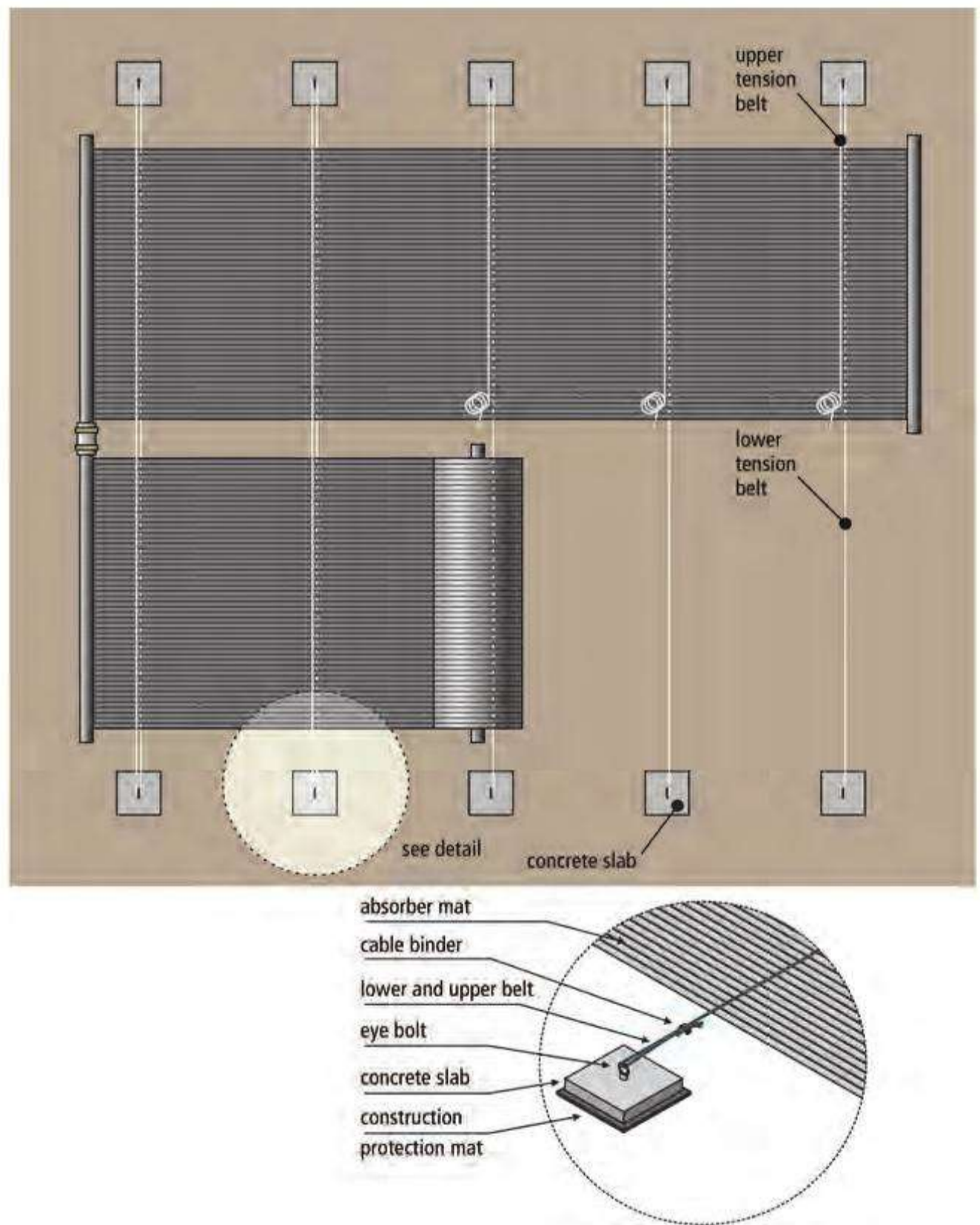

Figure 7.18.
Fixing the absorber with tension belts
and concrete slabs on a flat surface

The mounting of absorbers with tension belts is also suitable for pitched roofs (Figure 7.19). Here, however, another type of point fixing must be chosen, which will vary according to the type of roof. This is also true for steel rails, which are more frequently used for pitched roof installation. With tiled roofs this point fixing can be made, for example, with roof hooks, as used for on-roof collector installation.



Figure 7.19.
Clamping absorbers with belts on an inclined roof

7.5.1.2 FIXING THE ABSORBER BY BONDING

The surface area of the most common types of roof covering (tiles, sheet metal, bitumen etc.) is smooth enough for it to be possible to bond the absorber to the background with a special adhesive, which is usually available from the manufacturers. According to the manufacturer's system and the roof pitch, the adhesive layers should be applied at spacing between 30 and 100 cm (11.8 and 39.4 inches). Some types of absorber have crosspieces on the back (see Figure 7.5), which not only create an insulating air cushion but also provide an additional seating surface for bonding purposes. With inclinations greater than 30° it is necessary to ensure that the absorbers do not slip until the adhesive has hardened. For this purpose a double-sided adhesive absorber-mounting tape can be fitted close to the adhesive mass, for example. When bonding absorbers it must be ensured that the background is always dry, grease-free, and not contaminated (see Figure 7.20).

7.5.1.3 FURTHER ASPECTS OF ABSORBER INSTALLATION

For pitched roofs, the tube absorber should preferably be installed along the ridge/eave axis. In this way dirt that has gathered between the tubes can be flushed away by the rain. The absorber lengths can be very simply installed here by

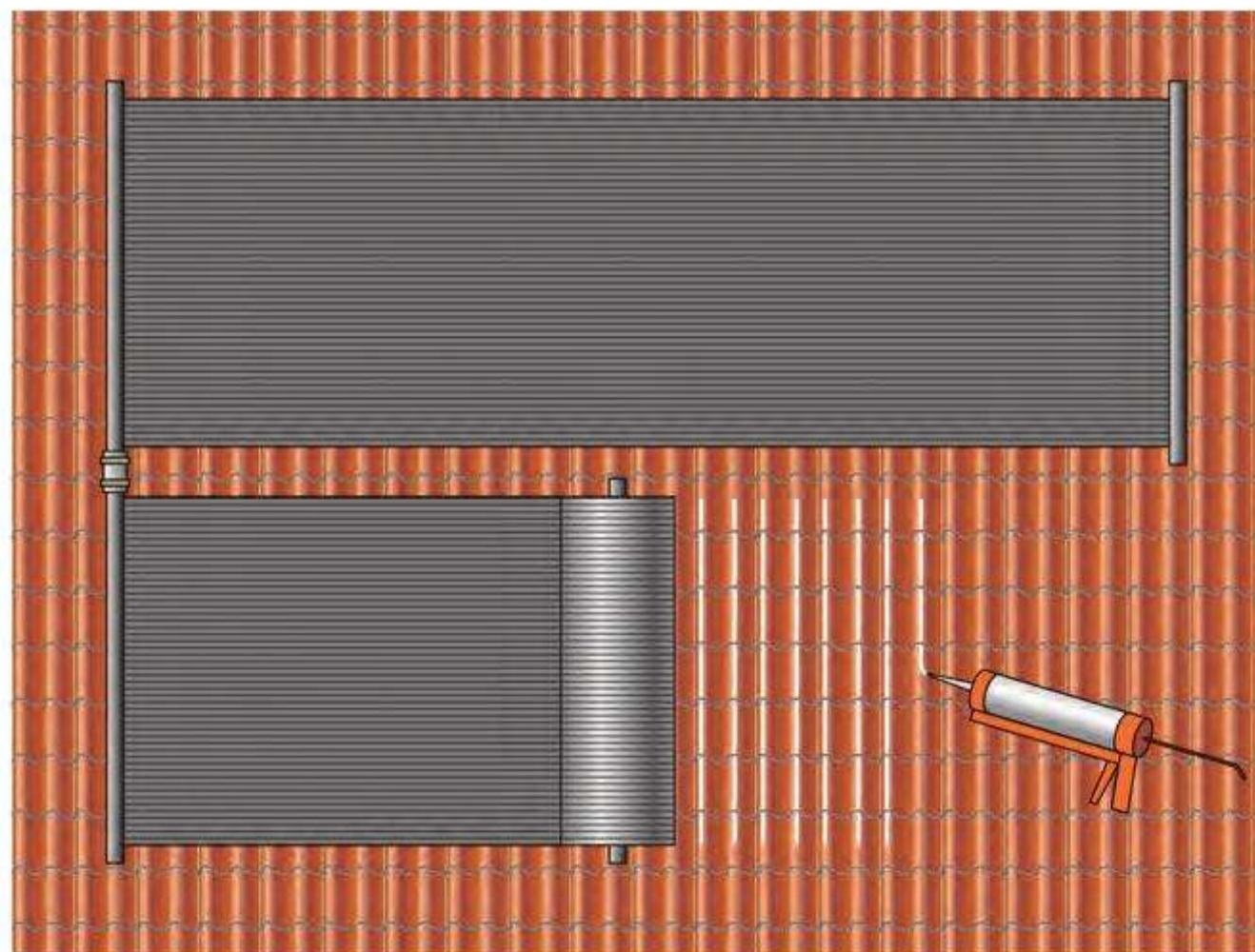

Figure 7.20.
Bonding of absorber lengths on a pitched tiled roof

'suspending' them from the collector and distributor pipes. They can again be prevented from slipping by means of belts. However, if transverse installation is selected for hydraulic reasons or because of the often-larger width of the roof surface, the absorber surface should be cleaned at least once per season (at the start of season) by spraying. This is also necessary for absorber fields mounted on flat roofs, as the dirt cannot be flushed away naturally by the rain.

If the roof has a pronounced profile (for example box section sheeting with large gaps at the top), a plastic pipe can be laid in the gap to prevent sagging of the absorber mats (see Figure 7.21).

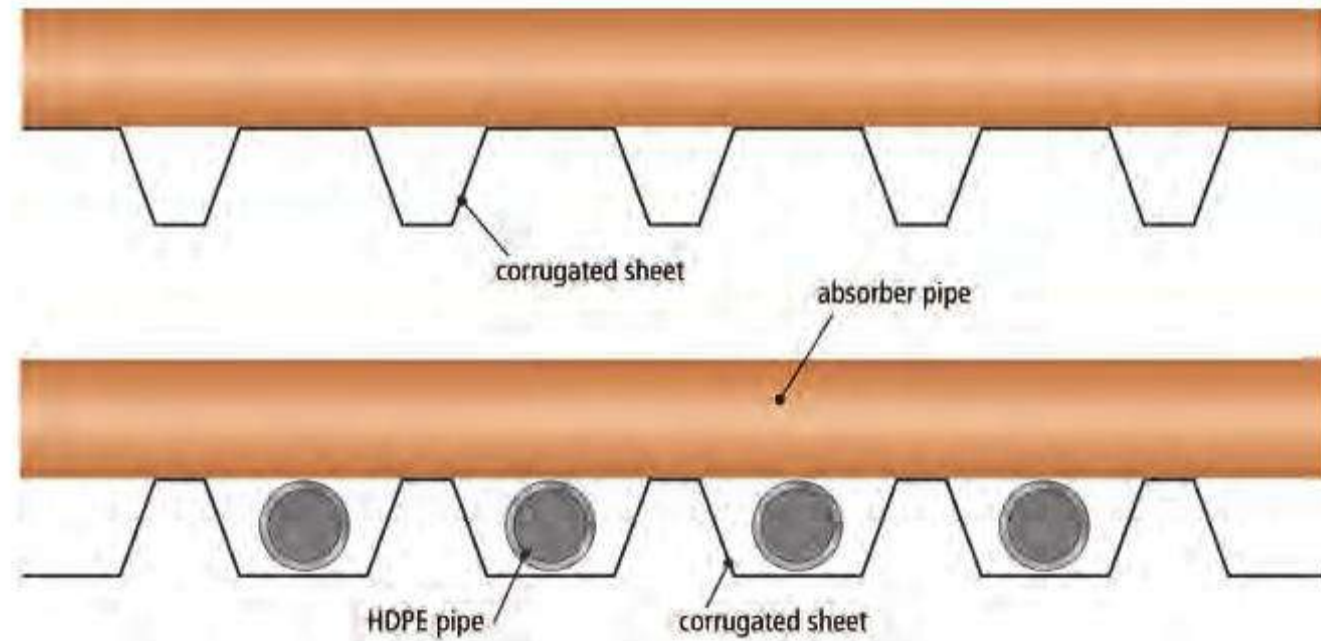

Figure 7.21.
Trapezoidal sheeting with plastic pipe
inserted to prevent sagging of the
absorber

7.5.1.4 GROUND LEVEL INSTALLATION

As has already been indicated in the design section of the chapter, it may be that insufficient roof surface is available – particularly for public swimming pools, where several 100 m² of absorber field are required. In this case, it may be possible to install the system at ground level. Security from wind forces can be provided in the same way as for flat roof installation. It is also essential that the absorber field is protected from plant or weed growth. To do this, the flattest possible surface should be prepared while still allowing rainwater to seep through easily and preventing plant growth over the long term.

For additional protection the absorber area can be fenced off. Low hedging at a suitable distance protects the absorber field from wind and hence reduces heat losses by convection.

7.5.2 Pipeline installation

The relevant technical regulations (such as EN 805 in Europe) should be used for installation work. In addition the pipe lengths between absorber field and swimming pool should always be chosen to be as short as possible. Because of the low operating temperatures, thermal insulation is not normally used for the pipes. Special attention should be paid to length expansion of the plastic pipes due to the varying temperatures. If pipes are not to be insulated they should be covered with a black protective coating, which will protect them from UV radiation and help them to absorb additional heat from the sun.

7.5.2.1 COLLECTION AND DISTRIBUTION PIPES

In general the type of fixing that is used depends very much on the absorber system and the type of roof skin. The collection and distribution pipes are fixed to the roof with either screw clamps or anchors similar to those used for the on-roof assembly of flat collectors.

Since the absorber collection and distribution pipes are usually made of HDPE or PVC, the temperature-related expansion must be taken into account here. Individual pipes can, for example, be linked by rubber sleeves (see Figure 7.22). If the pipes to be connected do not directly butt against one another the temperature-related expansion can be compensated for by the rubber sleeve.

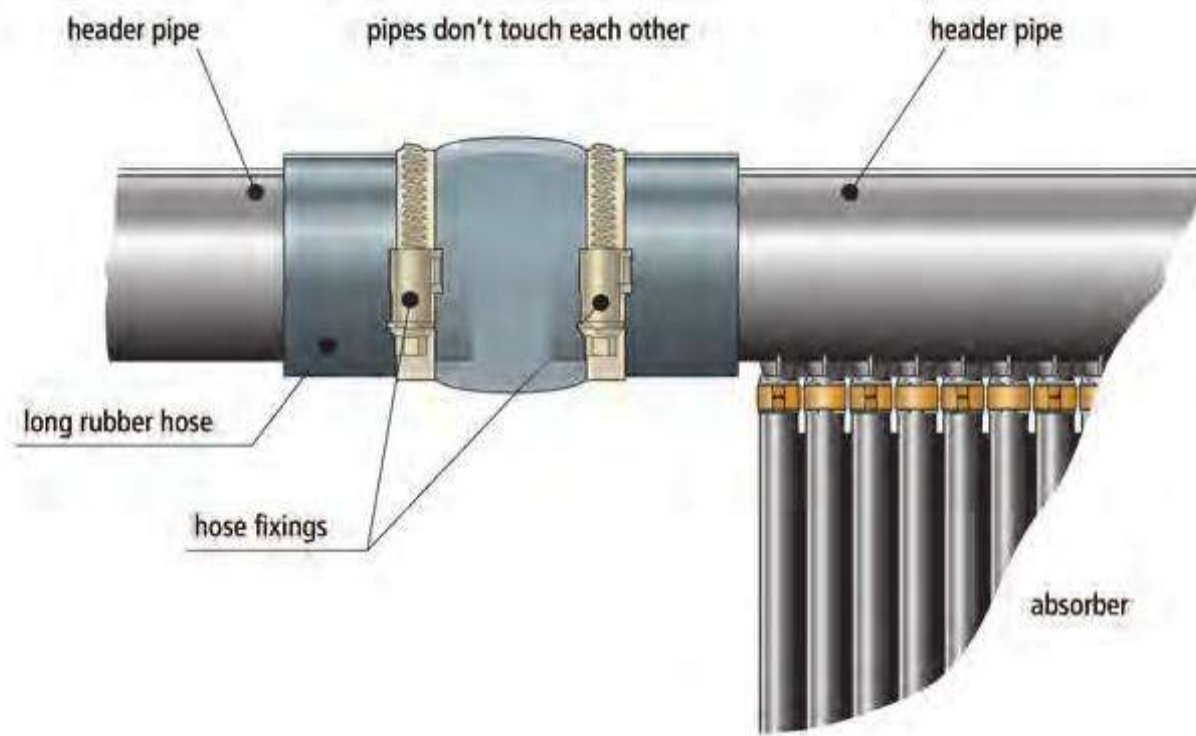

Figure 7.22.
Rubber sleeve connectors for collector
pipes to compensate for temperature-
related expansion

7.5.2.2 SOLAR CIRCUIT

The piping for the solar circuit consists of plastic pipes. PVC pipes are often used but, if possible, PE or PP pipes should be used for environmental reasons. The pipes are fitted to buildings with screw clamps, and between the building and the swimming pool the pipes should be laid underground if possible. PVC pipes are connected together with a suitable adhesive. The common grey PVC pipes must not be subject to UV radiation and should therefore be laid under the roof or underground, or be given a protective coating. Black PVC pipes and their corresponding fittings are, however, permanently UV-resistant.

PE and PP pipes can be connected together by heating element stub welding (previously called butt welding). As this method is significantly more expensive than gluing PVC pipes and requires the relevant specialist knowledge, it is used mainly in municipal swimming pools. The ends of the pipes must be smooth and perpendicular to the pipe axis, so that a permanent leak-proof connection can be achieved. The heating element, in the form of a thin disc, is guided between the pipes to be joined, where it heats the ends of the pipe. The pipes are in a retainer to ensure that the pipe axes match up with each other. The heating element is then removed, and the ends of the pipes are pushed together under pressure.

Long pipelines should be attached at one fixed point, in a floating arrangement, to allow for expansion along the length. The temperature range in which the pipe operates extends from -20°C (-4°F) in winter to $+70^{\circ}\text{C}$ (158°F) when the absorber pump is switched off (stagnation). With a heat expansion coefficient of 0.2 mm/mK (for comparison, copper is 0.016 mm/mK) and a 30 m (98.4 ft) pipeline this gives a length change of 540 mm (21.3 inches). The pipeline should be fitted on freely floating



Figure 7.23.
Example of sliding installation of pipe
with anchor clamps

loose seating (Figure 7.23). Furthermore, flexible sections and expansion bends should be installed at regular intervals from the fixed points (10–15 m; 32.8–49.2 ft).

7.6 Operation and maintenance

Solar systems in open-air pools normally operate fully automatically. The controller takes over the operation and switches the absorber pumps on and off. After a new installation, intervention may be necessary in the control strategy, but this should only be performed by an expert.

At the beginning of the season the absorber surface should be examined for contamination, and brushed or sprayed clean as necessary. The use of high-pressure cleaners is not recommended, because of the risk of damage. Also at the start of the season the system must be thoroughly bled, which for large and multiple absorber fields represents a significant cost, owing to the necessary manual work.

For public swimming pools in particular it is recommended that the personnel are given a basic knowledge of the function of the solar system. This means that they can check the operating parameters at regular intervals, and should be able to recognize errors. A control system that monitors the yields makes this work easier. These figures can then be used both for regular checks and to provide the swimmers with visual information at a suitable location.

Individual damage to absorbers can be rectified very simply. A damaged finned tube can either be completely or partially exchanged between collector and distributor. The damaged piece is cut out and repaired with a new absorber tube, sleeves and the necessary clamps.

At the end of the season the absorber field should be emptied. Even if EPDM absorbers have survived frost without damage, germs can form in water that is standing for a long period. PP absorbers, on the other hand, must be emptied as they are not frost resistant. Compressed air is normally used for the emptying process. The collector and distributor pipes and the solar loop are emptied via the discharge taps.

7.7 Costs and yields

In central Europe (solar irradiation about 1000 kWh/m²) the average solar energy yield of the system per swimming season (mid May to mid September) is approximately 250–350 kWh/m²; that is, the system operates with a solar radiation of approximately 650–700 kWh/m² per season with an average system utilization of about 40–50%. In tropical climates this may increase to 40–50% of the irradiation over the whole year.

Very favourable relationships thus arise for the economy of the system. The operating advantage of solar open-air pool heating arises mainly for single-source heating. Two heating methods are compared in Table 7.3: conventional heating and single-source solar heating. The assumed boundary conditions were central European climate, 1620 m² (17,438 ft²) pool surface, 900 m² (9688 ft²) absorber surface, period considered 15 years, interest 6% per annum, and standard assumptions for maintenance and operating costs. The comparison with conventional energy costs shows that, even without a grant, solar open-air pool heating is cheaper than conventional heating.

Table 7.3.
Comparison of total annual costs
(gross) for the single-source systems
solar and gas heating

	Conventional heating (gas)	Solar heating
Investment	€36,000/\$36,000/£25,200	€81,800/\$81,800/£57,260
Capital cost (per annum)	€3708/\$3708/£2596	€8425/\$8425/£5898
Usable energy (kWh/a)	325,000	276,000
Auxiliary energy (kWh/a)	1625	5520
Fuel consumption (kWh/a)	342,000	–
Gas and electricity costs (per annum)	€14,196/\$14,196/£9937	€705/\$705/£494
Maintenance cost (per annum)	€715/\$715/£501	€818/\$818/£573
Total annual costs (per annum)	€18,619/\$18,619/£13,033	€9948/\$9948/£6964
Heat price (per kWh)	€0.054/\$0.054/£0.039	€0.036/\$0.036/£0.025

In the case of dual-source heating the solar system can also provide cost advantages, as conventional fuel is saved. However, economic operation is possible only within a limited range of certain parameters. The most influential parameters here are conventional fuel costs and the set temperature of the pool water.

Contracting models can be of interest for local authorities in the event of a lack of finance. In this case an investor and operator of a solar system sells ‘warm swimming pool water’ to the local authority. This financially attractive alternative also minimizes the risk for the operator.

7.8 Examples

7.8.1 Solar heating of a private swimming pool

The owners of a solar system for open-air pool heating in Kettinger Str., Berlin Marienfelde, have had a swimming pool for many years. As business people with little free time for visiting an open-air pool or a lake they decided to invest in a leisure pool in their own garden. They had considered the possibility of solar heating for the pool over a long period, but it was several years before the family decided upon solar heating.

The solar system was installed in the spring of 2002. The pool size of over 50 m² (538 ft²) would require an absorber area of between 25 and 50 m² (269 and 538 ft²) according to section 7.4.2.1. As the family’s swimming pool has had a roll-up cover for many years, the absorber surface area of 25 m² (269 ft²) on the roof of the house was sufficient to achieve a pleasant pool water temperature (Figure 7.24).



Figure 7.24.
Private solar system for pool heating

The system is designed so that the pool temperature can be maintained at a particular value by means of a connection to the boiler. However, according to information from the family, this additional cost could have been saved, as during the first season with solar-heated pool water no conventional heating was required at all.

The EPDM absorber is aligned towards the west and installed on a tiled roof with an inclination of approximately 45°. The absorber lengths were secured against slipping by bonding the absorber to the curve of the roof tiles.

7.8.2 Solar heating of a municipal open-air pool complex

The summer pool at Mariendorf belongs to the Berlin swimming pool authority. It is situated in the Tempelhof area in the south of Berlin, in the suburb of Mariendorf.

The open-air complex has one swimming pool of about 1000 m² (10,764 ft²) and a learners’ pool with the same pool surface area. Previously the pool water was heated

to the required set temperature of 24°C (75.2°F) during the season with a gas boiler. The boiler had to be shut down in 1999, and the technical department of the Berlin swimming pool authority considered replacing the conventional heating with a solar system for heating the pool water. Because of the total pool surface area of about 2000 m² (21,528 ft²), an absorber surface of about 1400–1600 m² (15,069–17,222 ft²) was required, according to design guidelines. The flat roof surfaces of the shower and changing room buildings were available for the installation of the absorber. These have a gross roof area of approximately 1700 m² (18,299 ft²). With the corresponding circuit arrangements and pipeline installation it was possible to install an absorber surface area here of 1589 m² (17,104 ft²) (Figure 7.25).



Figure 7.25.
Solar system for heating open-air pool
water in the Mariendorf summer pool,
Berlin. Source: DGS

Because of the position and shape of the roof surfaces the absorber field was divided into two areas, which were each operated with their own pump:

Field 1: 1041 m ²	Pump 1	Field 1(a) 722 m ²
		Field 1(b) 319 m ²
Field 2: 548 m ²	Pump 2	Field 2(a) 422 m ²
		Field 2(b) 126 m ²

Fields 1(a) and 1(b), and 2(a) and 2(b) have parallel flow.

All the swimming pool water is conditioned by means of a central filter system and a pure water pool. From the pure water pool, both swimming pools are fed in parallel with filtered and solar-heated water. This arrangement therefore does not allow one of the pools to be supplied as a priority with solar-heated water.

The absorber fields are hydraulically separated from one another. A solar pump is installed for each field, which is started up in the event of sufficient solar radiation. Control of the solar system is carried out by the controller for the complete swimming pool water conditioning system. A radiation sensor determines whether sufficient solar radiation is available to start the solar pump. Then the absorber fields are fed with filtered water from the pure water pool. The fresh water feed to replace the evaporated surface water can take place directly via the solar circuit and therefore permits lower feed temperatures and high efficiencies.

The considerable experience of the absorber manufacturer (AST) was available during the planning of the system. The system was installed by a Berlin heating installation company. Because of the tight financial situation of the Berlin Senate an attempt was made to find a contracting partner for this system. The installation company took this on, with the following conditions:

- running time: 10 years
- heat price: with a minimum consumption of 500,000 kWh, €0.023/kWh; with a consumption of more than 500,000 kWh, €0.013–0.023/kWh.

In the season of 1999 the system had a solar yield of about 520,000 kWh. The system data can be called up by means of long-distance data transmission from the controller. The investment cost of the system was about €128,000 (€82.00/m² of absorber surface); the subsidy from the Investment Bank Berlin and the financial authorities was 43%.

Visitors to the pool are informed about the solar yield and the pool temperature by means of a large display in the entrance area.

Some system data:

- collector surface area: 1589 m² (17,104 ft²)
- pool surface area: 2000 m² (21,528 ft²)
- started up: 1999
- operator: Berlin swimming pool authority, contact partner, Mr Thoma
- installation: GSM Heizung Sanitär, Berlin
- planning: GSM and AST, Austria
- yield: Over 500 MWh/a
- degree of system utilization: approximately 50%.

8 Solar air systems

8.1 Introduction

Air-operated solar systems are comparable with solar systems in which the heat transfer medium is a liquid. However, air as the heat transfer medium in solar systems has very different physical properties from those of water (see Table 8.1), which has marked effects on solar air systems:

- Air heats up faster than water, owing to its much lower heat capacity. This means that in solar air collectors useful temperatures can be reached even at low irradiation levels.
- Energy storage in air systems is more expensive and can only be done indirectly, as the heat transfer medium – air – is itself unsuitable for energy storage.
- Heat transfer from the absorber to the heat transfer medium is worse for a solar air collector than for a similar-sized solar collector using a liquid medium, mainly because of the lower thermal conductivity of air.
- Energy transport by means of air requires higher mass or volumetric flows in comparison with energy transport in liquid heat transfer media. Air systems therefore always require thorough planning and installation to minimize the use of auxiliary energy.

Table 8.1.
Some material values for air and
water at 25°C and 1 bar

	Air	Water
Density (kg/m ³)	1.185	998,200
Specific heat capacity, <i>c</i> (mass) (Wh/kgK)	0.28	1.16
Specific heat capacity, <i>c</i> (volume) (Wh/m ³ K)	0.31	1158
Thermal conductivity (W/mK)	0.026	0.559

As a heat transfer medium, air offers the following advantages and disadvantages.

The simple system structure can be seen as an advantage. Unlike systems based on liquids, there are no problems with respect to system safety with air as the heat transfer medium, because of the properties of air. Air cannot freeze or boil: therefore no measures are necessary for frost protection, nor are precautions required for the stagnation situation. Moreover, air is significantly less corrosive than liquids. This also increases the service life of the collectors. A general advantage of using (solar) air collectors when heating habitable spaces is the lower temperature level of the feed air into the rooms, as compared with the necessary higher feed temperature of classical wet-based space heating. It is therefore possible to design for lower temperatures, which has a positive effect on the collector efficiency. In addition, some of the heat transfer losses involved in classical water heating are not incurred.

A disadvantage is that, because of the lower heat capacity and poorer heat conductivity compared with those of liquids, larger duct diameters and exchanger surfaces are required for the heat transfer to other media.

Overall these properties permit a very simple system design for the direct solar heating of buildings, as no separate circuit is required for this task. The air flowing through the collectors can be led directly to the building. Furthermore, the fresh make-up air for buildings can be solar heated, permitting greater volumes of fresh air and improving indoor air quality while reducing or eliminating additional energy needs.

For the sensible integration of a solar air system into a building it is advantageous if a system for controlled (mechanical) building ventilation is already installed; if not, then such a system should be installed. With the low energy requirements of new buildings, and the necessarily thick building skins, controlled ventilation is also installed more frequently in public-sector house building. The lower transmission

losses from the house, in connection with heat recovery, can lead to even lower energy consumption. By means of a sensible combination with solar air systems, it is also possible to input solar gain in addition to the energy savings. As both ventilation systems and solar air systems operate with the same medium, it is possible to integrate such a system without great expense. But even when no mechanical ventilation system is installed, it is possible to make use of a solar air heating system.

In passive houses, however, the use of solar air collectors is important for economic reasons, as the heat energy requirements in spring and autumn are mostly low, owing to the high passive gain. This leads to a requirement for thermal storage, for which the simple and inexpensive solar air systems are less suitable. See Figure 8.1 for an example of a solar air system.



Figure 8.1.
Example of a solar air system. Source:
Grammer, Amberg

8.2 Components

8.2.1 Collector types

Solar air collectors can be differentiated according to the type of absorber flow pattern, or the type of collector cover.

8.2.1.1 DIFFERENTIATION ACCORDING TO TYPE OF ABSORBER FLOW PATTERN

Solar air collectors can be classified into four types of construction, depending on the way in which the heat transfer medium (air) is brought into contact with the absorber (see Figure 8.2).

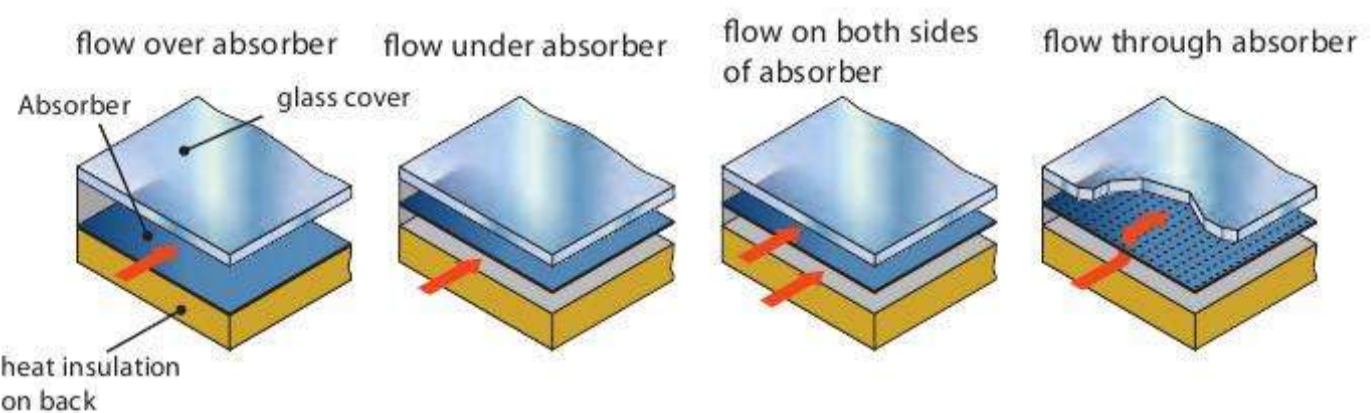

Figure 8.2
Designs of solar air collectors according
to absorber flow pattern

FLOW OVER ABSORBER

Here, the absorber lies directly on the thermal insulation and the air to be heated flows over the top.

FLOW UNDER ABSORBER

This type of absorber has an air channel between the absorber and the thermal insulation through which the air flows. This prevents the flowing warm air from coming into contact with the cover, which significantly reduces the convective heat losses from the front.

FLOW ON BOTH SIDES OF THE ABSORBER

In comparison to the flow under absorber, here the absorber has the airflow around both the upper and lower sides. The heat transfer from the absorber to the air is improved in this way, but heat losses can occur on the front side.

FLOW THROUGH THE ABSORBER (MATRIX COLLECTOR)

Here, the absorber consists of a porous plate (also called absorber matrix), which the air flows through. The absorber matrix can for example be made of fleece or fabrics (metallic or non-metallic). Here, unfavourable rising pressure losses can become apparent, if the flowed through fabric gradually clogs with dirt or dust. This type of absorber is often used in practice without thermal insulation, framework and transparent cover.

8.2.1.2 CLASSIFICATION ACCORDING TO COLLECTOR COVER

As for liquid-based collectors, solar air systems also have collector variations in which the most simple and hence inexpensive design is aimed for. A non-covered air collector has a greater heat loss compared with a glass-covered absorber owing to the lack of transparent cover, particularly with higher absorber temperatures. Its efficiency is thus lower. This design can, however, be of interest if working with lower absorber temperatures, such as the example of preheating surrounding air (see Figure 8.8). Because the material costs are reduced and the production is simplified, with this type of collector and with suitable boundary conditions very low heat-production costs can be obtained. For applications in which higher operating temperatures are needed in the solar air collector, insulated and glass covered solar air collectors are selected.

8.2.1.3 THE ABSORBER MATERIAL

For air collectors with plate-shaped absorbers, preferably, metallic absorber materials are used (such as steel, stainless steel, aluminium, or copper). For the above mentioned matrix collectors, fleeces and fabrics come from both metallic (e.g. steel wool, wire mesh from copper) and from non-metallic materials (e.g. cotton fabric, plant fibres, polyester fibre non-woven fabric).

8.2.1.4 THE ABSORBER COVER

Treatment of the absorber surfaces with metallic materials is common. Depending upon type of the treatment, the total costs of the collector will increase to varying degrees. Selective coatings, which are nowadays common for liquid-based collectors, entail a substantial increase in the price with small manufacturing runs. The bid price for absorbers can increase, for example, with a purchased quantity of 700 m² (7535 ft²) by a factor of three. Hence, for inexpensive air collectors, black and temperature-resistant lacquers are recommended.

8.2.1.5 PERFORMANCE AND EFFICIENCY FACTORS OF AIR COLLECTORS

There was for a long time no defined test procedure for air collectors which manufacturers and their products could undergo. In the context of the research programme 'Solar Heating and Cooling', IEA Task 19 'Solar Air Systems' of the International Energy Agency, benchmark/comparison tests have been conducted with the majority of the products present on the market. These tests provide reference points, in order to better estimate and to compare the efficiency of air collectors as well as significant influential variables. For the representation of air collector performance, two types of efficiency graphs are important:

For collectors, which are operated in a closed cycle (operation with circulating air), a diagram displaying the efficiency curve over the temperature difference is used (see Figure 8.3 left). However, with testing it was shown that the average collector or absorber temperature should not be used here, but instead the outlet temperature. For

this reason the efficiency curves from Figure 8.3 should not be compared to those of liquid-based collectors.

For collectors which operate exclusively with the intake of outside air, the representation of the efficiency is more suitable as a function of the mass flow (Figure 8.3 right).

For an absorber to be effective the type of absorber flow pattern and the heat transfer from the absorber to the airflow are crucial. Depending upon application, the correct balance must be found here. In building houses the target is, for example, specific temperatures with small mass flow. However, the effectiveness of the heat transfer of the absorber to the airflow is reduced. In contrast, the effectiveness of heat transfer increases with higher mass flow – however, the pressure loss in the collector and in the whole system increases.

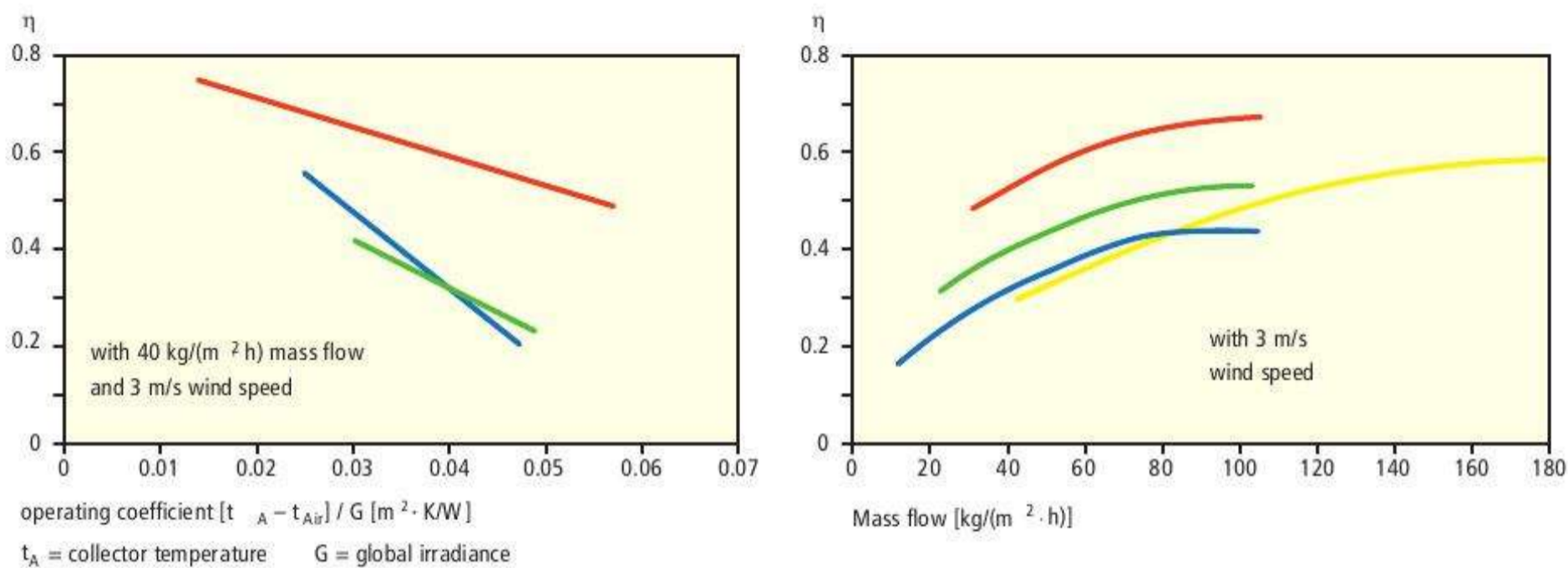

- Low iron, glazed collector with aluminium absorber designed as U-profile, selectively coated, flow under absorber (Manufacturer: Grammer, Schüco)
- unglazed collector, trapezoidal Aluminium absorber (Manufacturer: Solarwall)
- glazed absorber, varnished black, flow under absorber
- glazed absorber, varnished black, flow on both sides of the absorber

Figure 8.3. Efficiency curves of air collectors related to the outlet temperature (left) on the mass flow (right)

8.2.1.6 STANDARD AIR COLLECTORS

A standard collector corresponding to type (b) above is shown in Figure 8.4. It has a frame, thermal insulation on the back and sides, a transparent glass cover, and an absorber. The absorber consists of a coated aluminium sheet that is designed as a U-profile. Placed side by side, these profiles produce a ribbed profile for the transfer of the heat to the air that is flowing through.

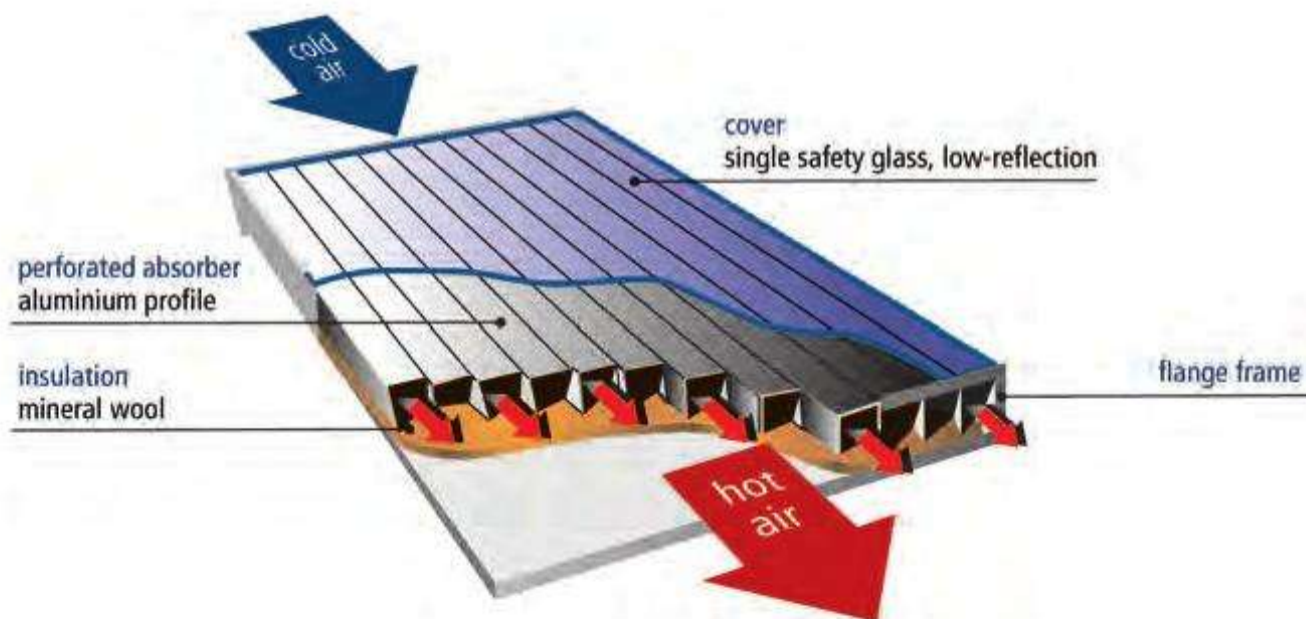

Figure 8.4. Schematic construction of an air collector with under-flow. Source: Grammer, Amberg

The collectors are available in different versions. For example, different depths are offered, depending on the system size. Increased airflow is permitted by the increased depth in larger systems.

In addition, because of the flow-specific series connection of the collectors, there are different modules available. The middle collector is connected on its narrow side to the end collectors by means of flanged connections. The end collectors have an

integrated air connection. This connection is either designed as a pipe connection, for example to lead the waste air from a building through the collectors, or it is fitted with an air filter integrated into the rear opening in order to lead fresh air directly through the collectors.

8.2.1.7 ROOF INTEGRATION

For new buildings, or during refurbishment, if it is planned to integrate the collector into the roof, the collector area is arranged and installed in modular form. Absorber troughs, whose height is derived from the required airflow (110–170 mm; 4.3–6.7 inches), without a transparent cover are used. They are offered in flexible dimensions of 400–1200 mm (15.8–47.2 inches) by 1000–2500 mm (39.4–98.4 inches). The collector surface is bordered by the roof-covering frame. For each row of collectors two air-connecting parts are required on the rear wall of the trough. A diverting module is used to provide a side airflow through two collectors. Finally a single pane of safety glass is placed on the absorber troughs. Collectors can also be mounted on flat roofs (see Figure 8.5).



Figure 8.5.
Air collectors placed on stands on the
roof of a factory building. Source:
Grammer, Amberg

8.2.1.8 PHOTOVOLTAICS-INTEGRATED AIR COLLECTORS GRID INDEPENDENT AIR COLLECTORS

To provide independent operation of the air ventilation in buildings without a separate power supply (allotments, mountain huts, holiday residences, etc.) collectors with an integrated PV module can be used. This supplies the electrical energy required to drive a d.c. fan when the sun shines.

The system is driven by the amount of available solar radiation and in most cases gets along without additional regulation. Besides the application in buildings without their own power supply, the system can also be operated in buildings with their own power supply. Here, it allows for the electricity supply to be switched off via main fuse during long operating breaks, while the solar air heating and ventilation system continues to operate. In infrequently used buildings, this grid independent and burglar proof ventilation system has the additional effect of heating up the air: it dehumidifies air and thereby contributes to the preservation of the building substance as well as its inventory.

The company Grammer offers different standard systems with collector surface areas between 2 and 10m² (21.5 and 107.6 ft²). Basically, the structure is similar to standard collectors. A part of the transparent cover is however replaced by a module surface, which serves to drive the fan. The size of the module surface area depends on the size of the solar air system. The larger systems are meant for applications in residential buildings. It offers a simple supply air system.

The new collector series with slightly modified collector measures and different direction change (deflected collector) has also been available as a grid-independent air collector since 2003.

The company Aidt Miljø from Denmark offers a so-called 'Summer house package' in order to ventilate and preheat weekend houses. They use flow-through absorbers, either a 2 mm (0.08 inches) thick special felt or perforated aluminium absorber.

HYBRID COLLECTOR

A further use of air collectors is for controlled rear-surface ventilation of PV modules in so-called hybrid collectors. Instead of solar protection glass, the air collector is partly or completely covered on the front with modules. The PV modules produce electricity, which is fed into the grid. They also produce waste heat, which is used to heat up air for ventilation or heating purposes. This synergy leads to a higher efficiency of the PV modules due to the lower module temperature.

Such systems usually have an installed performance of several kWp or some dozen square metres of collector surface area. The sizing complies with the desired PV performance and their grid supply, as well as the necessary amount of air required in the building on or at which the system is installed. The allocation of modules can take place in increments from 50 Wp (one fifth of the transparent cover) up to 250 Wp (complete substitution of the transparent cover).

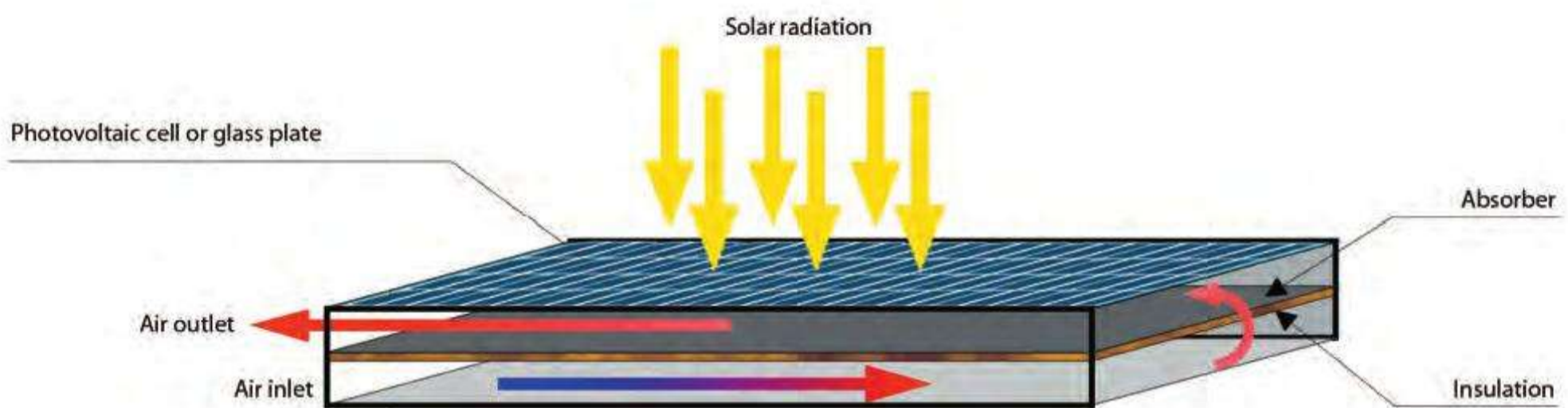

Figure 8.6.
Schematic design of a PV-integrated air collector (Manufacturer: Grammer Solar GmbH, Amberg)



Figure 8.7.
Hybrid collectors for solar air heating and generation of electricity for an automotive paint shop (Manufacturer: Grammer Solar+Bau GmbH, Amberg)

8.2.1.9 FAÇADE COLLECTORS

Another interesting application for air-operated solar systems is their integration into façades. Here the collectors can, for example, completely replace the façade in a stud-bolt design, or they can be placed on an existing façade.

As the heating of a building normally takes place in winter and in the transition periods – that is, with low solar elevation angles – vertical arrangement of the collectors has some advantages. For economic reasons, too, façade integration of solar air collectors can be of interest, as during the new building or restoration of a façade costs can be saved in the façade construction. These can then be set against the costs of the solar air collector façade. For the inexpensive integration of solar air collectors into a façade, as well as from the energy point of view, integral planning is of great significance.

8.2.1.10 THE SOLARWALL™ – SYSTEM, TRANSPIRED AIR COLLECTOR

Apart from the façade collector system with transparent glazing, the uncovered collector, which has already been mentioned, is the one that is mainly used (Solarwall system, see Figure 8.8). Here a perforated, dark-coated metal absorber sheet is used as the outside jacket for a façade. By means of regulated suction of the solar-heated air boundary layer on the outer side of the metal sheet, the heat is collected and led to the ventilation system for heating purposes. This simple, direct method can be configured to preheat fresh ventilation air for buildings, thus improving indoor air quality while reducing energy cost. In lower latitudes this same vertical wall can be applied above a roof to capture heat incident on the inclined surface equally well. Applications for drying agricultural crops such as coffee, cocoa and tea have yielded excellent results in many countries.

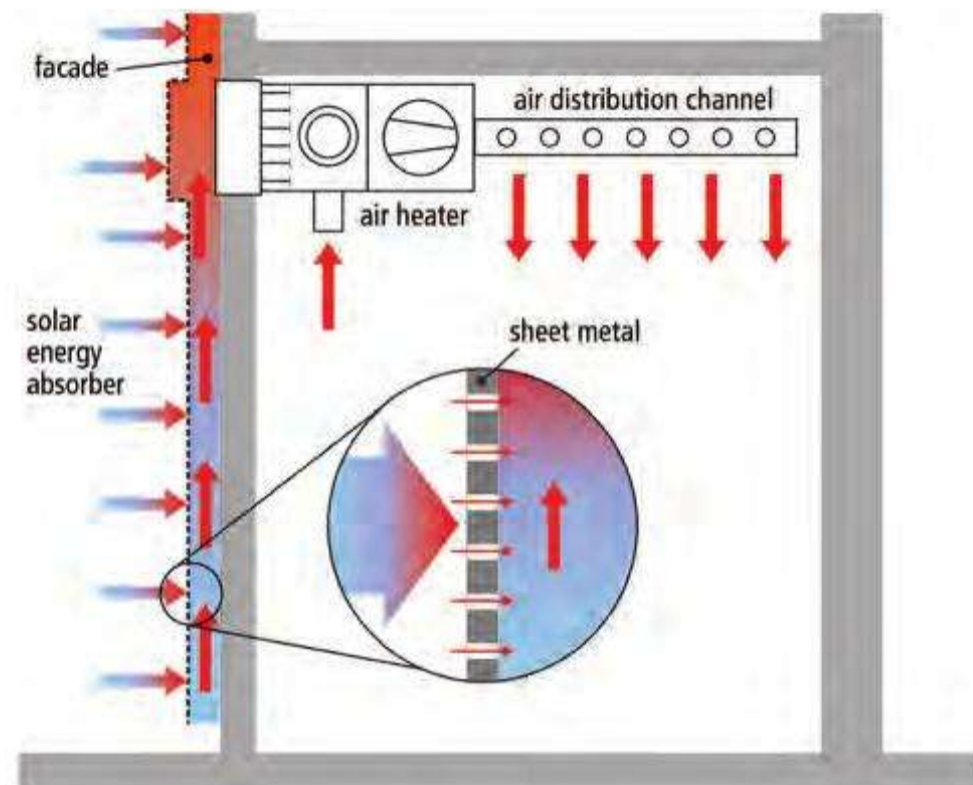

Figure 8.8.
Construction of a solar air system with
an unglazed aluminium absorber. Source:
Solarwall International Ltd, Göttingen

8.2.2 Fans, blowers

The fans that are normally used in solar air systems are standard trade components as used in normal ventilation systems. In addition to the radial fans that are most frequently used, there are also axial and cross-flow fans. Axial fans can best be used in round pipelines, but they are mainly used in exhaust air systems. Cross-flow fans operate particularly quietly, but have a low air delivery rate and are mostly used only in special cases. Because of its flexible connecting options and its higher delivery rate capacity, the radial fan is preferred (see Figure 8.9). By means of different designs of blade (curved, forward or backward), optimum adaptation to the existing volumetric flows and pressure differences can be achieved.

For solar air systems in factory buildings with very high flow rates, the fans must have power settings of several kilowatts. With an annual average of 2000–2500 operating hours the power consumption required here is significant. In evaluating the additional energy requirement, the pressure loss in the solar air collectors and in the



Figure 8.9.
Radial fan

necessary pipes is crucial because of the need to integrate the solar air collectors. With careful planning and design of the system it is possible to reduce the additional electrical energy required to approximately 2–5% of the thermal gain.

8.2.3 Piping

The piping of solar air systems corresponds with the requirements for a normal ventilation system. They must be made from non-combustible materials, and must also be corrosion resistant. The materials mostly used are steel and stainless steel plate. Under certain conditions aluminium is also used. For hypocaust systems (see section 8.3.3.3), apart from the normal wrapped spiral-seam tubes, plastic tubes made of PE or PP are also used for the air passages through the building parts.

Circular cross-sections are mostly used for smaller channels; the pipes are made in a wrapped spiral system. For large air channels square or rectangular sections are normal. The pipelines are mostly available in lengths up to 10 m (32.8 ft). They are connected together at the butt joints with gate valves or rebates and clamps; in individual cases they are also welded. Flexible tubes are used to cope with angles that circumvent inaccessible passages and deviations from standard values (connection of collector at inclinations $\neq 45^\circ$). Collector connections are additionally provided with thermal insulation. For pipes led outside the building, UV- and weather-resistant heat insulation is recommended. Inside the building this is not necessary.

In order to reduce noise, the use of sound-reducing components is recommended for solar air collector systems. This is particularly true for systems with high user requirements for comfort. High levels of noise occur particularly with high airflow speeds, and also at curvatures because of air friction and because of the use of low-friction wrapped spiral-seam tubes. Therefore, a silencer (see Figure 8.10) is usually installed in front of the room inlet vents in order to reduce the noise load.

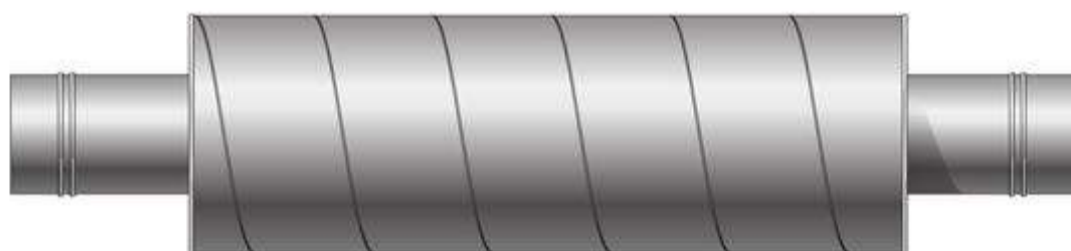

Figure 8.10.
Silencer

8.2.4 Heat exchanger and heat recovery units (air/water), recovery-solar-box

HEAT RECOVERY

The VDI 2071 distinguishes four categories of heat recovery systems, systems with:

- recuperators or plate heat exchangers
- circuit- or tube heat exchangers
- rotary heat exchangers with or without hygroscopic storage mass
- heat pumps.

In (solar) air systems mainly recuperators (recovery heat coefficient*), normally about 65% for large flow rates) or rotary heat exchangers are in use. These can achieve recovery heat coefficients of up to 90% and simultaneously permit moisture exchange, which can be used for air-conditioning. Overall, the range of heat recovery devices is very wide. Depending on the device, special designs can achieve greater heat recovery coefficients.

AIR-WATER HEAT TRANSFER UNIT

Solar air systems in residential buildings are usually conceived for the direct heating up of air and thus heating of buildings or spaces. Because in some climate zones in the summer no space heating is needed, the solar air system is not used in this period. By

* The recovery heat coefficient gives the temperature change that can be achieved by heat recovery with respect to the outer air or exhaust air side. In the case of devices with simultaneous moisture transfer, there is similarly also a moisture recovery coefficient.

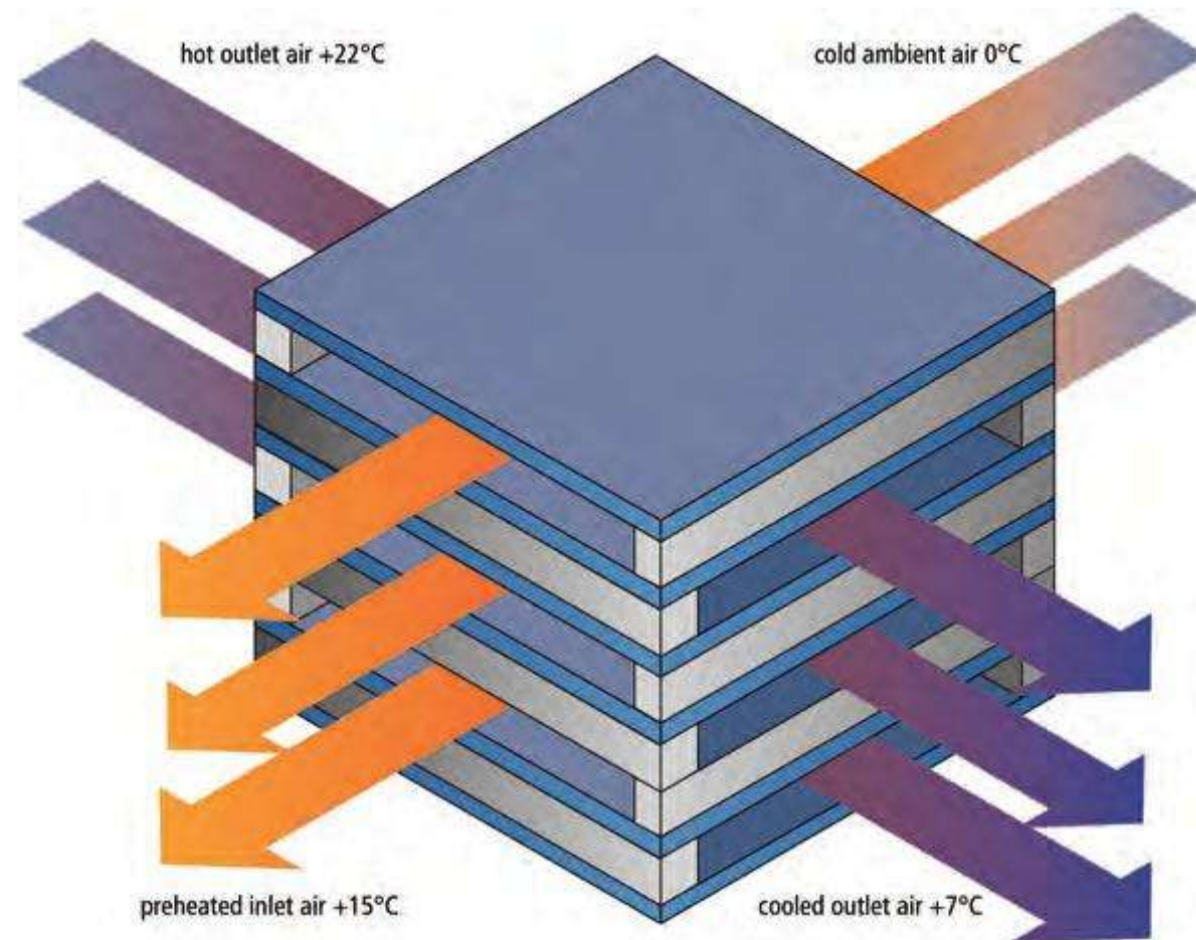

Figure 8.11.
Schematic outline of a recuperator with
example temperatures

integration of an air–water heat exchanger, excess heat can be transferred to the domestic water system in summer. The solar air system can thus be used more effectively and achieves higher efficiencies (see also section 8.7).

SOLAR BOX

The solar box enables additional use of the air collector systems for (solar) hot water generation. All necessary technological components are compact, easily accessible and readily preconfigured in the box. The water heating is carried out by an air–water heat exchanger. The six-tubes-to-a-row heat exchange surface, made from copper tubes and aluminium fins, ensures a highly efficient exchange of heat. The regulation or switching of the operating conditions is carried out by a standard 2-storage-solar control system. Here, according to temperature and requirement profiles it switches between heating/ventilation and domestic water heating. Depending on type series, the solar box is configured with an integrated or external fan.

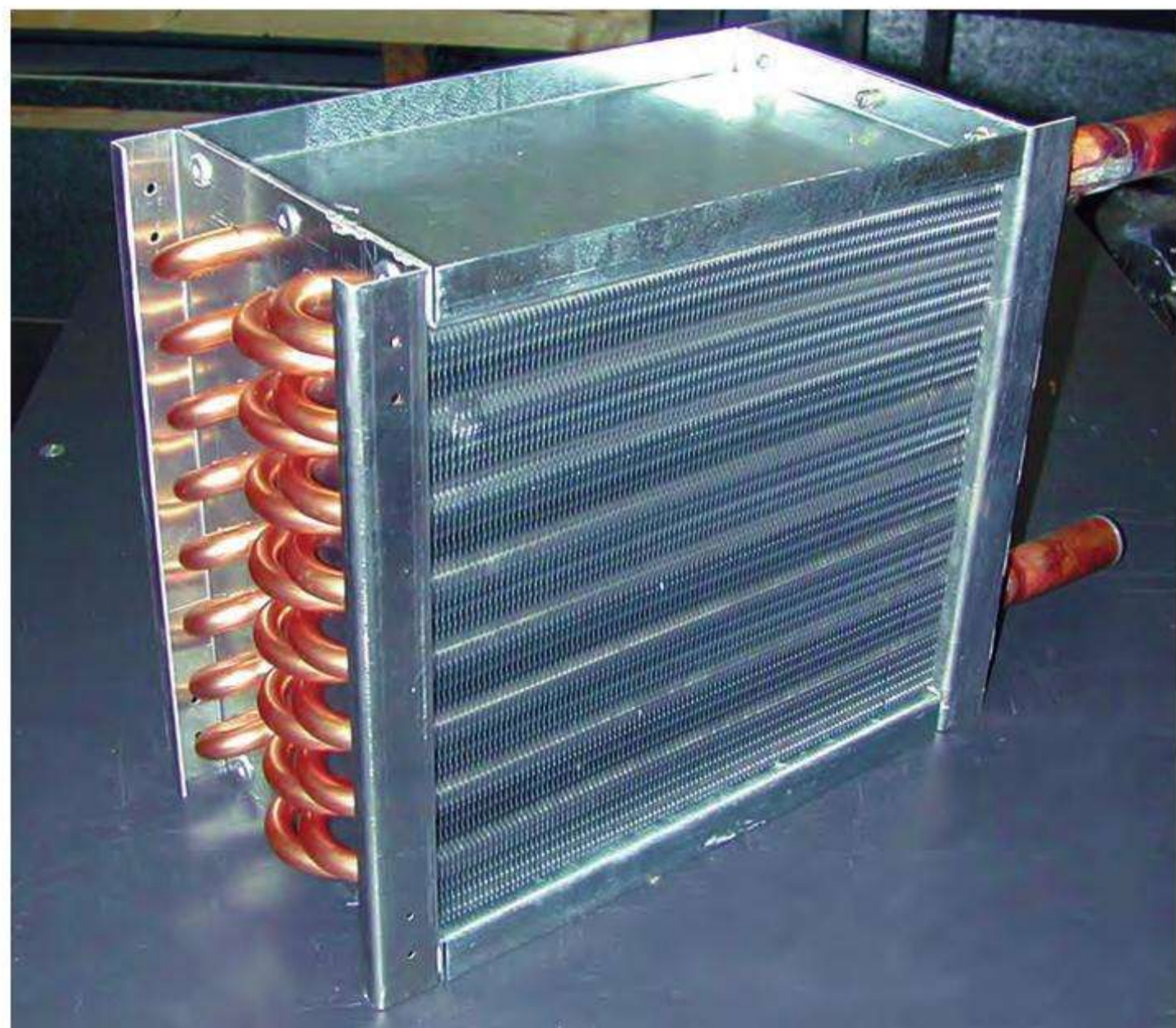

Figure 8.12.
Air–water heat exchanger (Manufacturer:
Grammer Solar GmbH, Amberg)

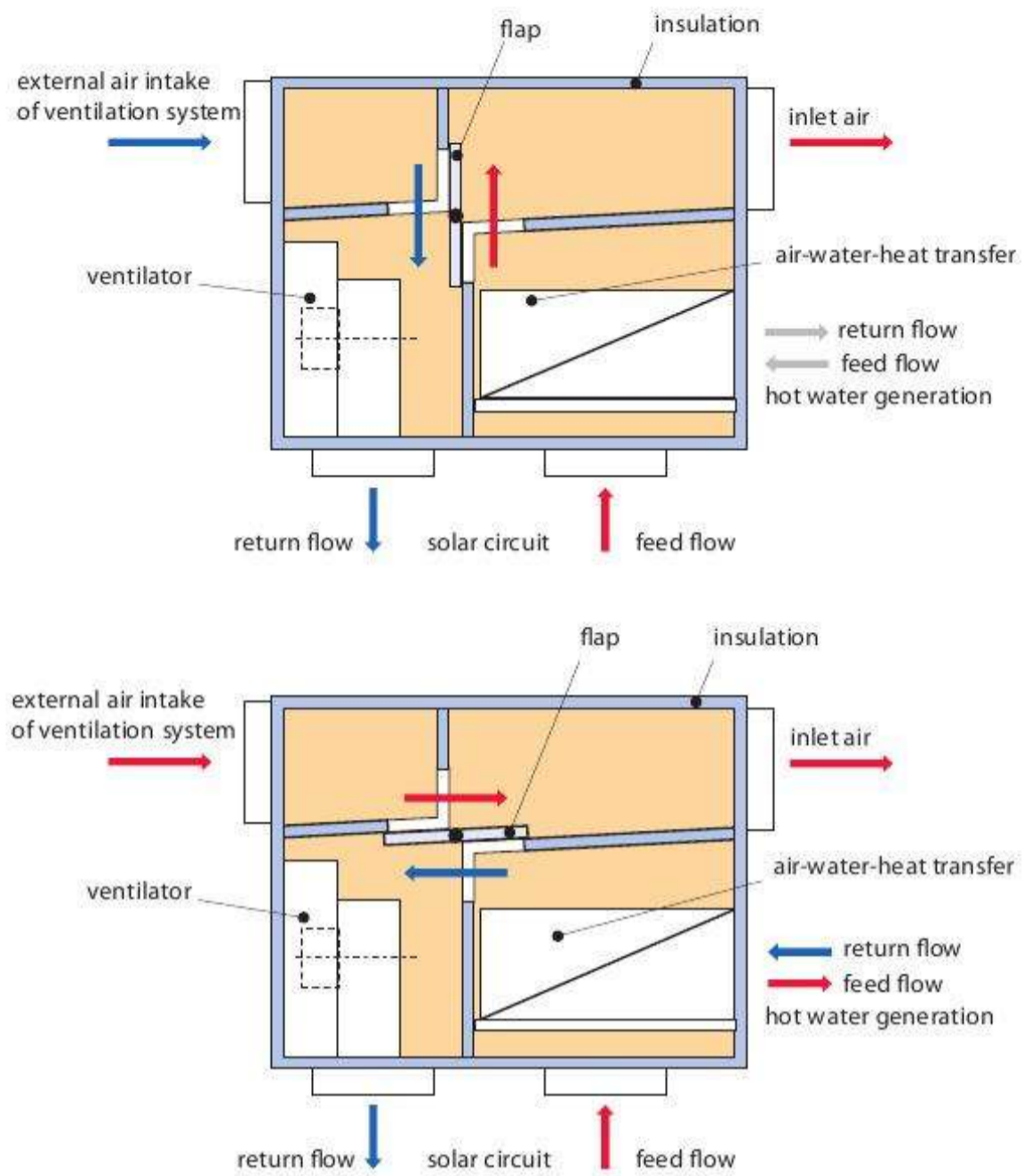

Figure 8.13. Structure and functioning of the recovery solar box, flap position heating and ventilating' (above) and 'water heating' (below)

8.2.5 Control

Standard temperature difference controllers can be used for the control of solar air heating systems. The controller compares the room air temperature and the collector temperature. If a given temperature difference (for example 5K between the collector (TKL) and room temperature(TSP)) is reached, the fan is started. If the temperature difference falls back between 2 to 4 K, the fan is switched off.

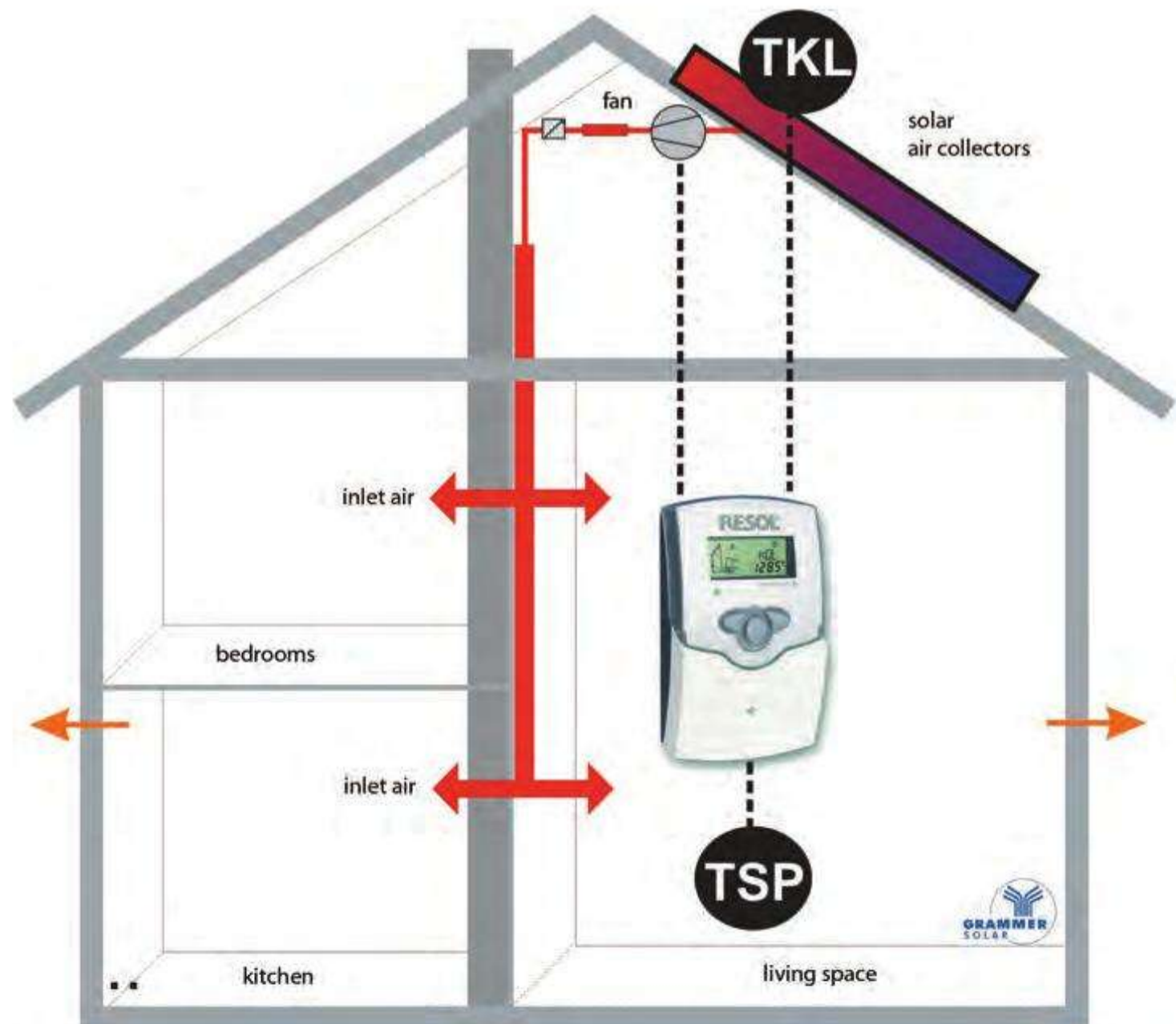

Figure 8.14. Simple control scheme of an air collector system

POSITIONING OF THE SENSORS

Solar air systems require that the temperature sensors must be positioned correctly, in order to ensure optimal operation. The collector sensor should be fitted inside the collector near the collector outlet, avoiding a thermal bridge.

The room temperature sensor should not be positioned in close proximity to supply air items and without direct sun exposure or other exposure to external heat sources. Usually, temperature sensors of the type KTY are sufficient, as solar air systems do not reach temperatures as high as liquid-based solar systems. In conjunction with data loggers and/or heat volume measurements, however, more precise sensors of the type PT 1000 should be used.

With Hypo- or Murocaust systems (see section 8.3.3.3) the reference temperature sensor is installed in the storage part of the building. Here, for example, a reasonable maximum temperature limit is situated at 35–40°C (95–104°F) for the storage part of the building.

CONTROL FOR ADDITIONAL DOMESTIC WATER HEATING

Solar air systems that transfer excess heat to the domestic water require a priority controller. Hot water preparation is then scheduled as a low priority. If the solar air system has reached the desired room temperature, the air stream is used for hot water heating (see section 8.3.3.4). At times when room heating is not required, the hot water is created exclusively by solar energy. Here, the system works in recirculation mode. A typical setting value for switching on the fan during water heating is $\Delta T = 10 \text{ K}$ (approximately). Achieving the maximum temperature of, for example, 65°C (149°F) in the domestic water store, the regulator switches off the fan.

FURTHER ASPECTS OF THE REGULATOR

A regulation of the number of revolutions per minute of the ventilators can be achieved in alternating-current motors up to a rated output of 0.5 kW by means of an electronic rotation speed controller. For higher performances three-phase-motors can be adapted to the operating point via a frequency inverter. For fans operating with direct current the number of revolutions can be controlled by electrical voltage, such as usually done with PV-operated air systems.

With large systems in buildings with complex ventilation and air-conditioning systems, the solar air system can be merged into the Direct Digital Control (DDC) used for ventilation/air conditioning.

For early detection of possible disturbances continuous monitoring of the system is recommended. The actual amount of produced solar energy can be significantly influenced in this way.

PV-OPERATED SYSTEMS

For solar air systems which are powered by a PV module, a temperature difference controller is not required for simple systems. The characteristic line of the fan and

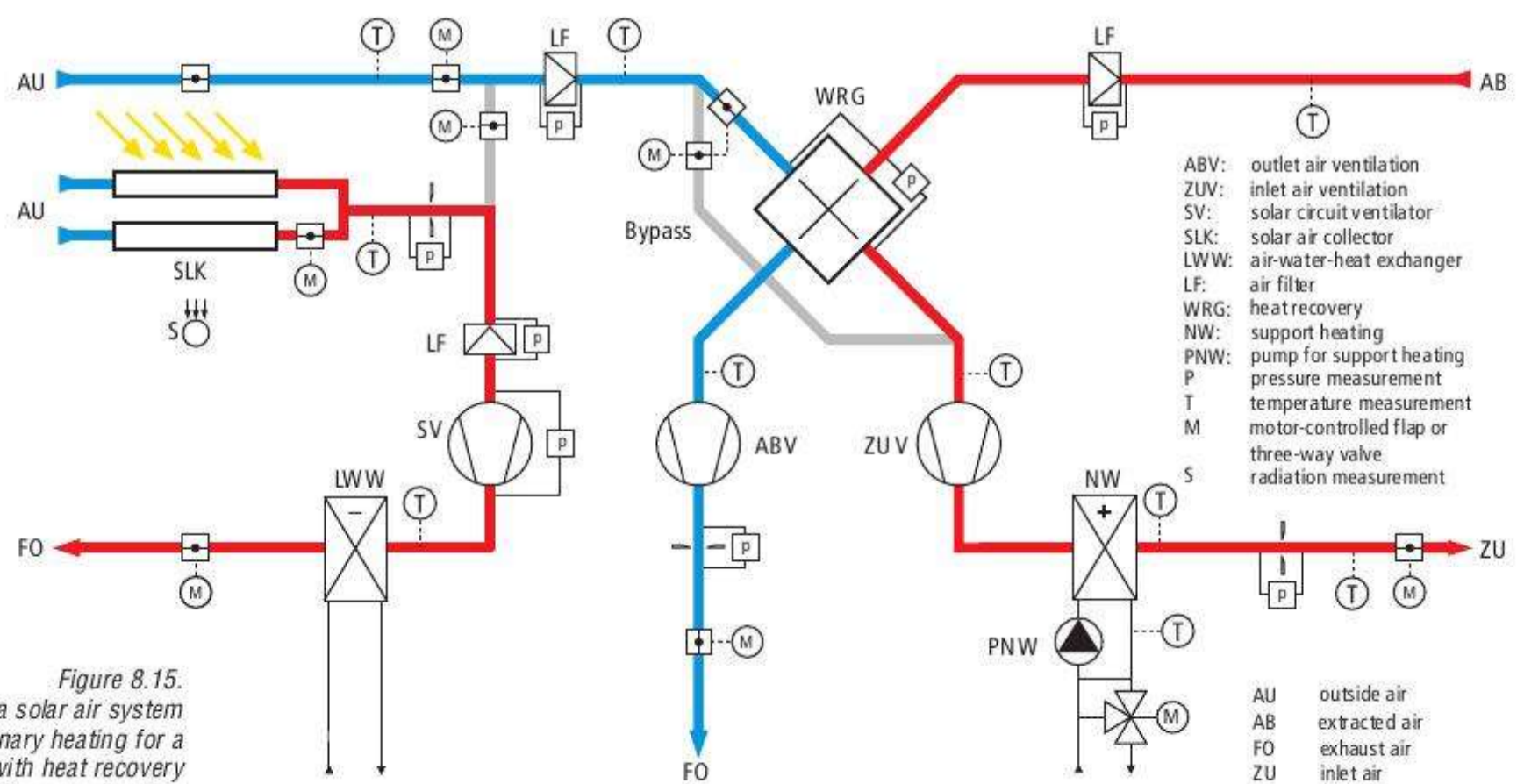

Figure 8.15. Control principal of a solar air system for solar preliminary heating for a ventilation system with heat recovery and for water heating.

module is adjusted by an adjustment transformer. The fan is switched on and off with a simple bimetal sensor (room thermostat). With PV operated solar air systems for heating support a temperature difference regulation is usually used. In order to realize a more accurate control of the installation, air and room temperatures are continuously compared to each other.

8.3 Systems

8.3.1 Central systems, decentralized systems and hybrid systems

8.3.1.1 CENTRAL SYSTEMS

Central systems essentially involve venting and air heating systems, where the technical solution is aimed at the building as a whole or at larger parts of the building.

VENTILATION SYSTEMS

Ventilation systems are systems aimed at facilitating the movement and exchange of air within a building without an implied heating function. It is important to note, however, that such systems may well contain heating elements aimed at ensuring the draught-free flow of ambient air into the building. For the space-heating requirement, additional systems are needed. The ventilation system generally pre-heats incoming air to the temperature of the rooms to be ventilated as required.

AIR HEATING SYSTEMS

Air heating systems add the additional task of compensating for the heat loss of the building to the ventilation system, covering the full heating demand of the building. Incoming air is therefore heated to the required (typically higher) temperature rather than the existent room temperature of ventilated spaces. Incoming air is therefore heated in relation to its temperature.

8.3.1.2 DECENTRALIZED SYSTEMS

Decentralized systems are ventilation systems in which each individual room or space has its own technical solution. In the simplest case it could be simple outside air intake elements. Usually, however, they use compact devices, which feature an intake of outside air and which can be further equipped with several other air conditioning components. Therefore, with decentralized systems there are also ventilation systems available which can be retrofitted to air heating systems by heat recovery and the reheating of air.

8.3.1.3 HYBRID SYSTEMS

With hybrid systems such system approaches cannot directly be classified as either one of the main groups mentioned above, such as residential heating systems with central air intake and ducting. The central element is, for example, the transportation of air into the residences. The residence's internal ventilation is the decentralized element. The exhaust air of the respective dwelling is led via a central exhaust line from the building usually across the roof. In these cases the heat recovery from that exhaust air takes place in each individual dwelling.

8.3.2 Further terms of ventilation technology

- ambient air systems
- air circulation systems
- hybrid air conditioning systems.

All forms of ventilation and air heating systems described in section 8.3 can, additionally to the systems mentioned above, be distinguished according to type and supply of air into the ventilation appliance or heater. One speaks of ambient air systems if the outside air flows directly into the devices; of air circulation systems, if air from the building only supplies the device; and of hybrid air conditioning systems if the device is served both with surrounding and circulating air. In addition to these

three types of ventilation, the air flows *exhaust air*, *outlet air* and *inlet air* must be defined, in order to achieve a definition of all air flows in a ventilation and air heating system.

Table 8.2.
Types of air flow according to DIN
1946 Part 1

Types of air flow	Abbreviation	Description
Ambient air	AU	Total air intake from outside
Waste air	FO	Total air discharged outside
Exhaust air	AB	Total air discharged outside
Circulating air	UM	The fraction of exhaust air which is used in the same system as supply air
Mixed air	MI	Mixture of air of different types or states (generally exhaust air and re-circulating air)
Inlet air	ZU	Total inflowing air

8.3.3 Air collector systems in housing construction

Air collector systems can be operated in different system configurations. The following can be used in housing construction.



Figure 8.16.
Solar air collector on the façade.
Source: Grammer, Amberg

8.3.3.1 SOLAR FRESH AIR SYSTEM (AIR HEATING WITH FRESH AIR)

This is the simplest sort of solar air system. The collectors have fresh air flowing through them, which is then blown into the building in heated form. There is no exhaust air system; the exhaust air leaves the building by leakage or through exhaust air flaps (Figure 8.17). The installation required for blowing solar-heated feed air into the building is minimal. All that is necessary is to conduct the air into the required rooms. This system is used mostly for retrofitting into existing buildings. If the required hygienic air change is brought into the building via the solar air collector system, every degree of temperature increase brings with it an energy saving. Thus, for example, with an outside temperature of -10°C (14°F) and a desired room temperature of $+20^{\circ}\text{C}$ (68°F), a temperature increase in the solar air collector of only 15 K reduces the ventilation-heat requirement by 50%.

8.3.3.2 SOLAR-SUPPORTED HOUSE VENTILATION

Because of the increasing improvements in the thermal insulation standards of new buildings, the sealing of the walls of buildings is constantly improving. This requires the use of a system for controlling the feed and exhaust airflows, into which the solar air system can be easily integrated. With corresponding solar radiation the fresh air is led through the collectors and heats the building (Figure 8.18). There it continues through the ventilation system, in which a heat recovery unit is usually also integrated.

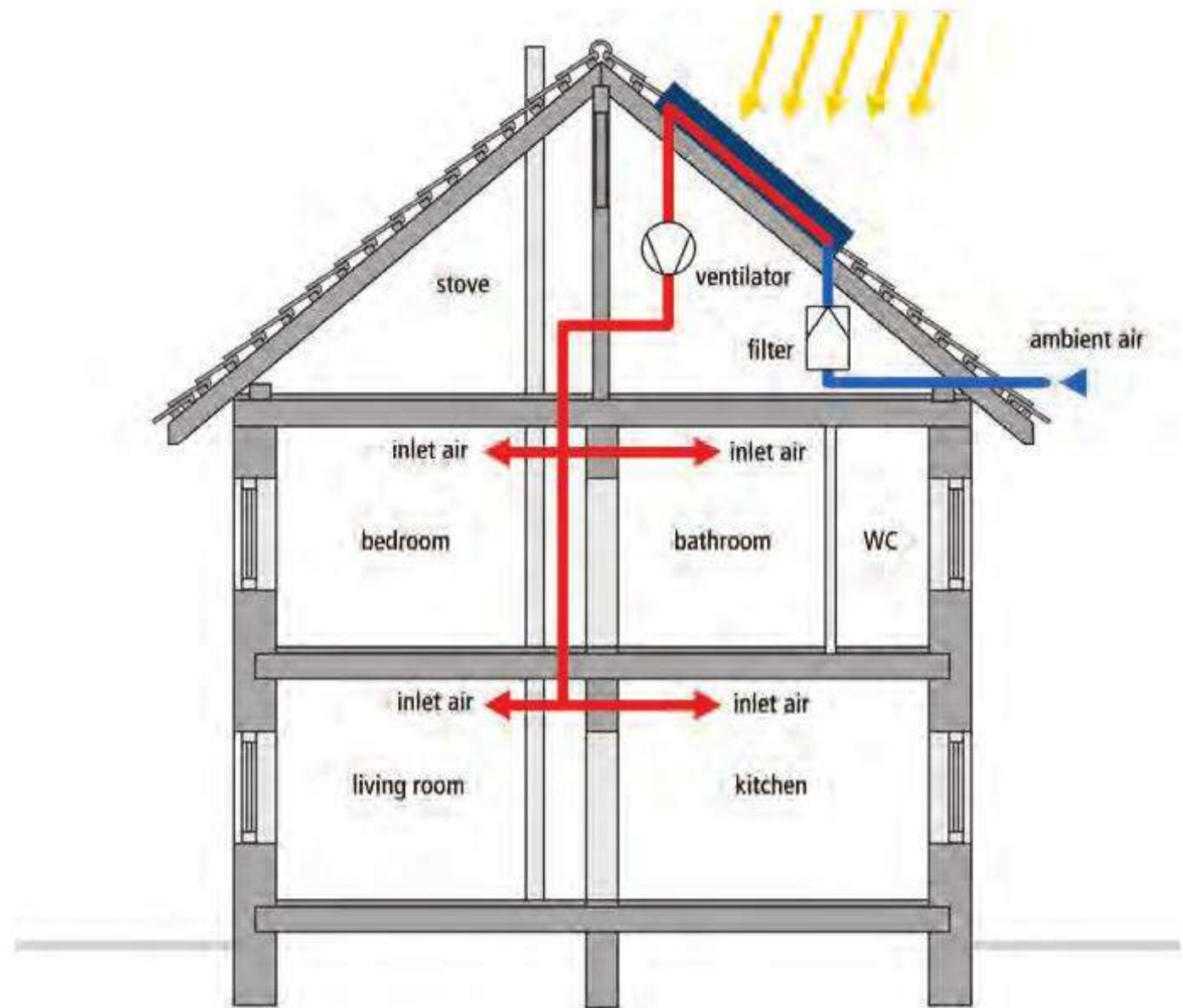

Figure 8.17. Elementary diagram of a solar air system with fresh air operation

In more complex systems a portion of circulated air can be returned to the collectors. Heat recovery and solar air systems, however, interact counterproductively. From an energy standpoint it is therefore advisable to connect the air collector system at the outlet side of the heat recovery unit. This reduces the yield of the solar air system; in reverse order, however, the heat recovery much less effectively transfers the excess heat from the building to the solar preheated air. Integrating domestic water heating makes sense too.

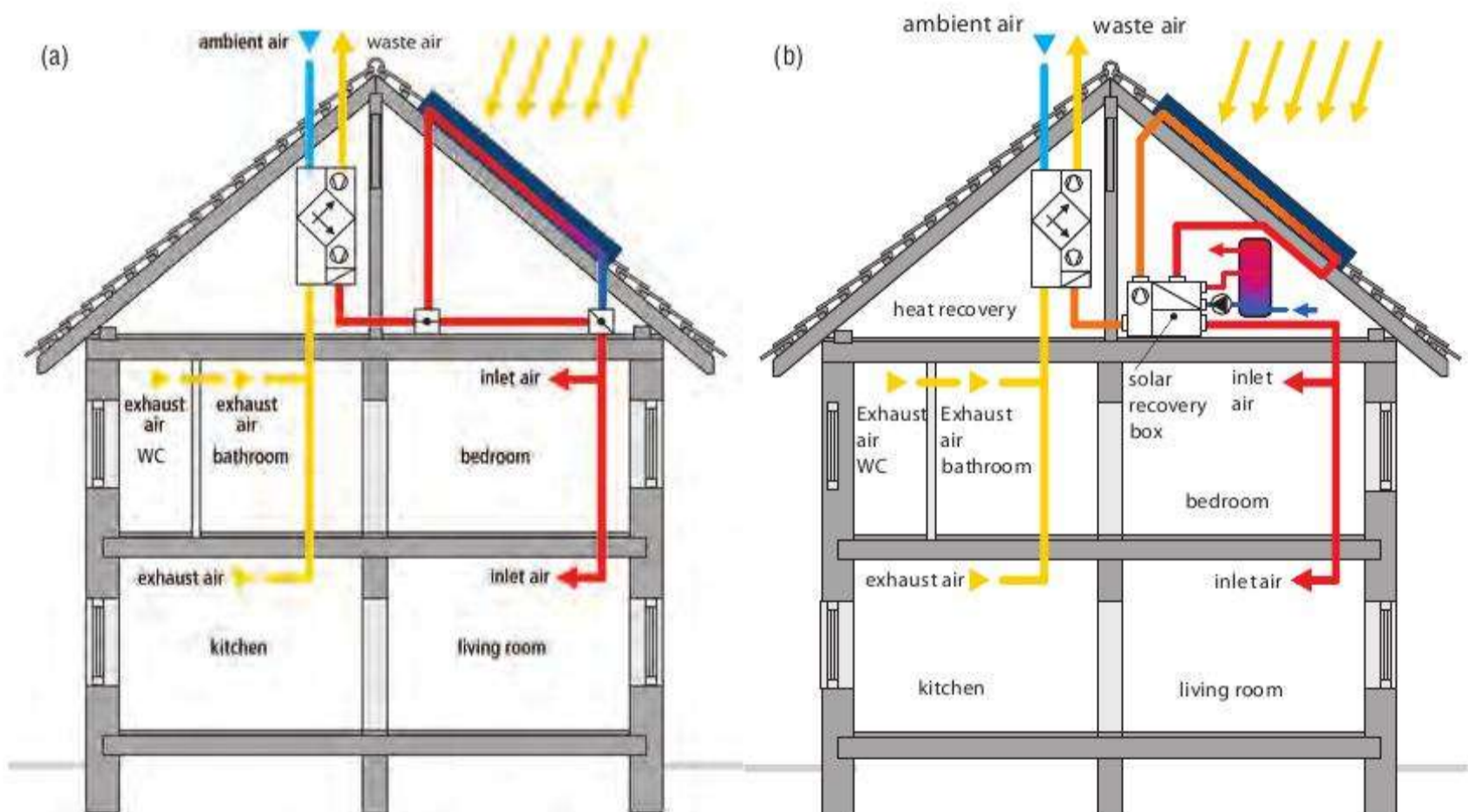

Figure 8.18. Elementary diagram of a solar air system with (a) heat recovery and (b) heat recovery and hot water generation

8.3.3.3 SOLAR AIR HEATING WITH STORAGE

In order to use solar air heating of a building at times that do not coincide with the solar radiation, the heat must then be stored. This plays a very important role, particularly in dwellings, as heat is required in the evening and at night.

To store the generated heat it must be transferred to a suitable medium. For this purpose gravel or stone storage vessels can be used, for example (see Figure 8.19), but these are usually linked to high costs.

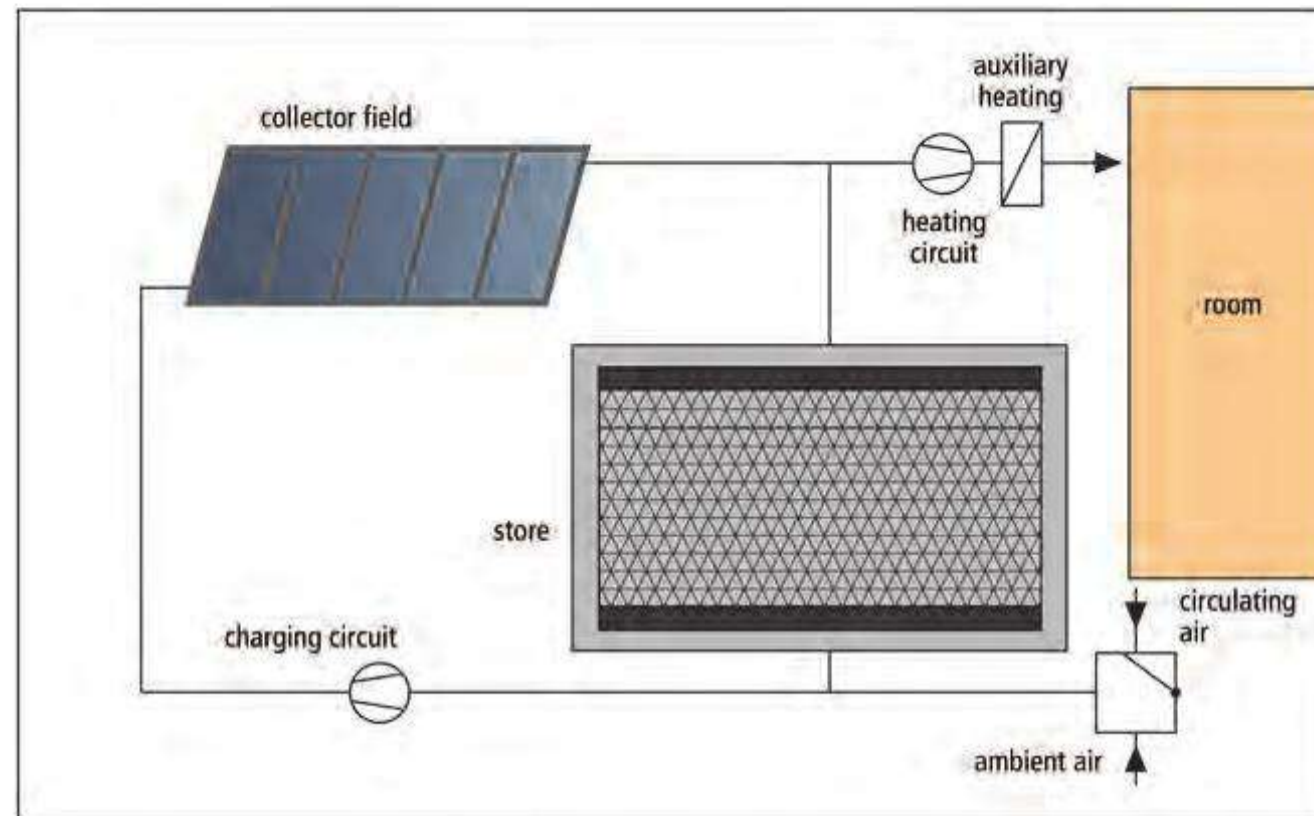

Figure 8.19.
Elementary diagram of a solar air system
with (stone) storage vessel

A comparatively cheap method of intermediately storing the solar heat is possible with *hypocaust systems* (see Figure 8.20), as long as a solar air system is planned for a building project from the very beginning. Here the warm air stream is led through parts of the building, such as walls or floors. The heat is transferred to the building component, and the component transfers this heat to the adjacent rooms with a time delay. Conventional heating can also be operated via this system in order to use it optimally.

In houses equipped with such a system, the collector surface area is often subdivided. One part feeds the hypocaust system; another feeds a controlled direct room heating system. In this case it is also sensible to incorporate optional switching of the hypocaust system to controlled ventilation, as the corresponding building component can only absorb a limited amount of heat.

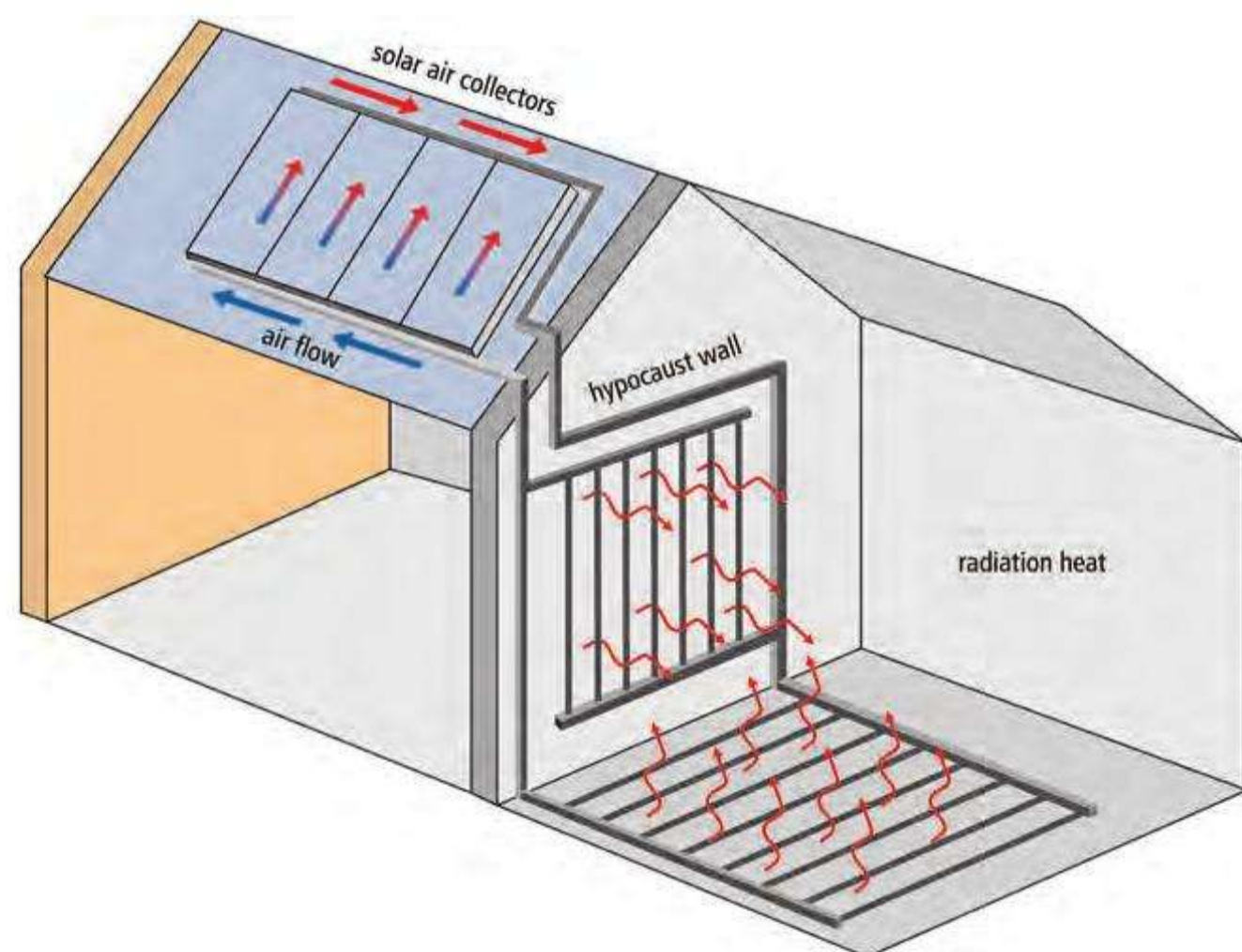

Figure 8.20.
Example of a building with hypocaust
wall and floor

8.3.3.4 SOLAR AIR HEATING AND DOMESTIC WATER HEATING

A sensible extension of the solar air system is the transfer of excess heat in the sunniest months to the domestic water. In the summer months room heating is normally not necessary, which means there is excess heat available. Between May and September (in temperate climates; November to March in the southern hemisphere) the solar-heated air can thus be used almost exclusively for domestic water heating, and the existing system can thus also be used sensibly within this period.

During the other months the domestic water heating is operated as a low priority, as the air collectors operate more effectively for room air heating and achieve greater solar yields. Once the set room air temperature is reached, a bypass valve is triggered. The system is now operated as a circuit in the same way as for water-based solar systems. The air–water heat transfer unit, which transfers the heat from the air to a separate liquid circuit with safety module and pump, is installed in the bypass circuit. This transfers the heat to the domestic water storage tank via an internal heat transfer unit (Figure 8.21). The liquid-based circuit is operated with frost protection as, otherwise, frost damage to the heat transfer unit could occur at air temperatures below 0°C (32°F).

A two-storage control system is necessary to control the system. The cost–benefit ratio for this additional investment for the heat transfer unit, domestic water circuit and safety module must be critically checked, but for most systems can be seen as being worthwhile.

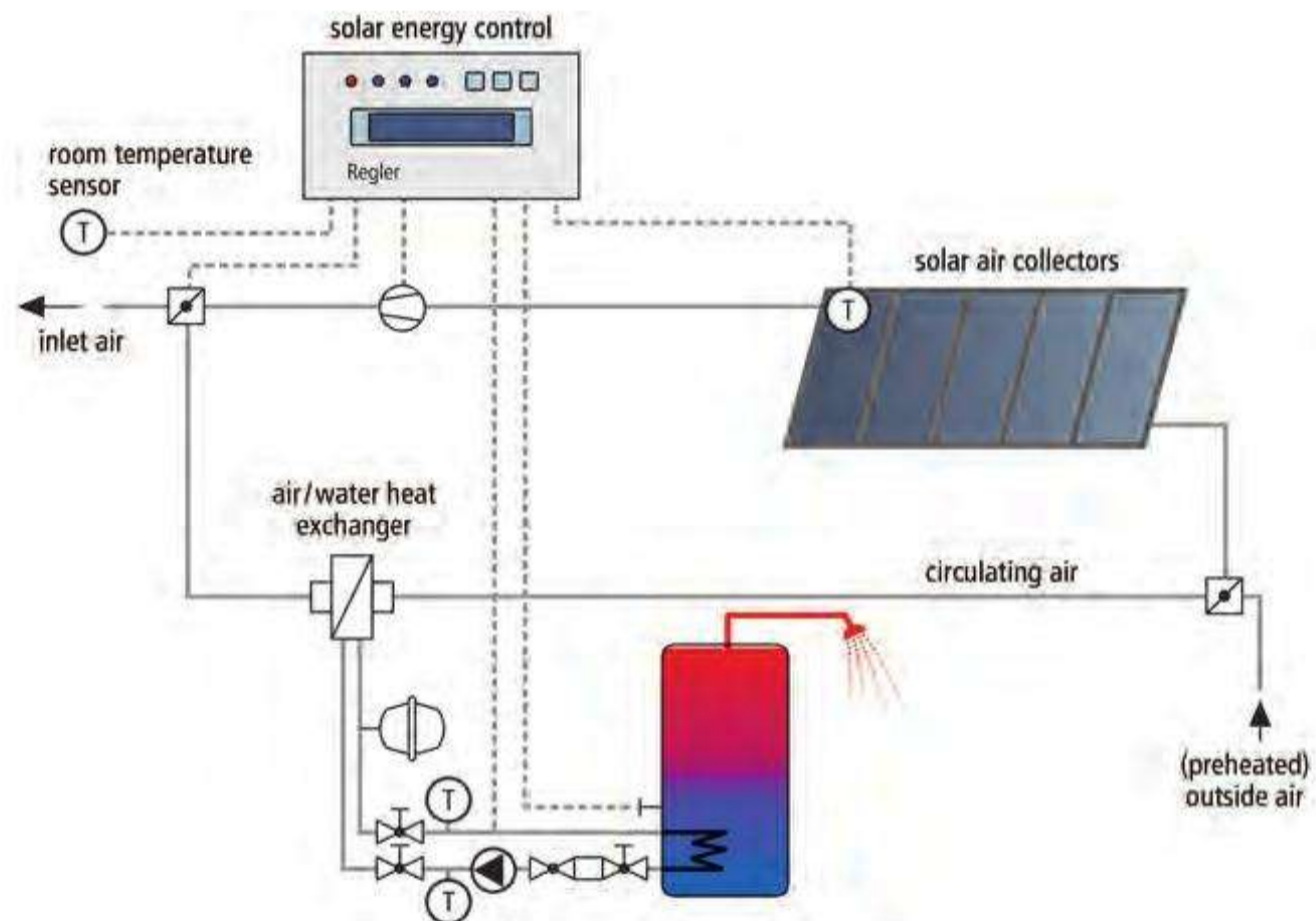

Figure 8.21.
Basic diagram of a solar air system
integrated into the domestic hot water
system

8.3.3.5 SOLAR AIR SYSTEMS IN LOW-ENERGY HOUSES

In new, very well-insulated buildings in temperate climates, it is almost possible to dispense with conventional room heating (combustion of fossil fuels) where a solar air system is installed. Because of the low heat requirement, the solar system can often supply the necessary heating energy in combination with a heat pump as a heat recovery system. However, it is necessary to consider here the primary energy balance in connection with the number of hours of operation of the heat pump over the year. For safety, low-temperature electrical convectors can be installed to cover the residual heat requirement on very cold days.

The system set-up is similar to that shown in Figure 8.22, but instead of the recuperator or rotary heat transfer units, the heat pump is used for heat recovery.

Because of the very low energy requirement of low-energy houses, it is still necessary to weigh up whether a solar air system should be installed. Because of the significantly higher proportion of hot water treatment in the total energy requirement, a solar thermal system for domestic water heating may well be more sensible under these circumstances.

For so-called passive houses (heat requirement ≤ 15 kWh/m²a) the use of solar air systems is often found not to be worthwhile, as their energy requirement is very low even during the transitional periods. The solar air system would only provide good yields in three or four months of the year.

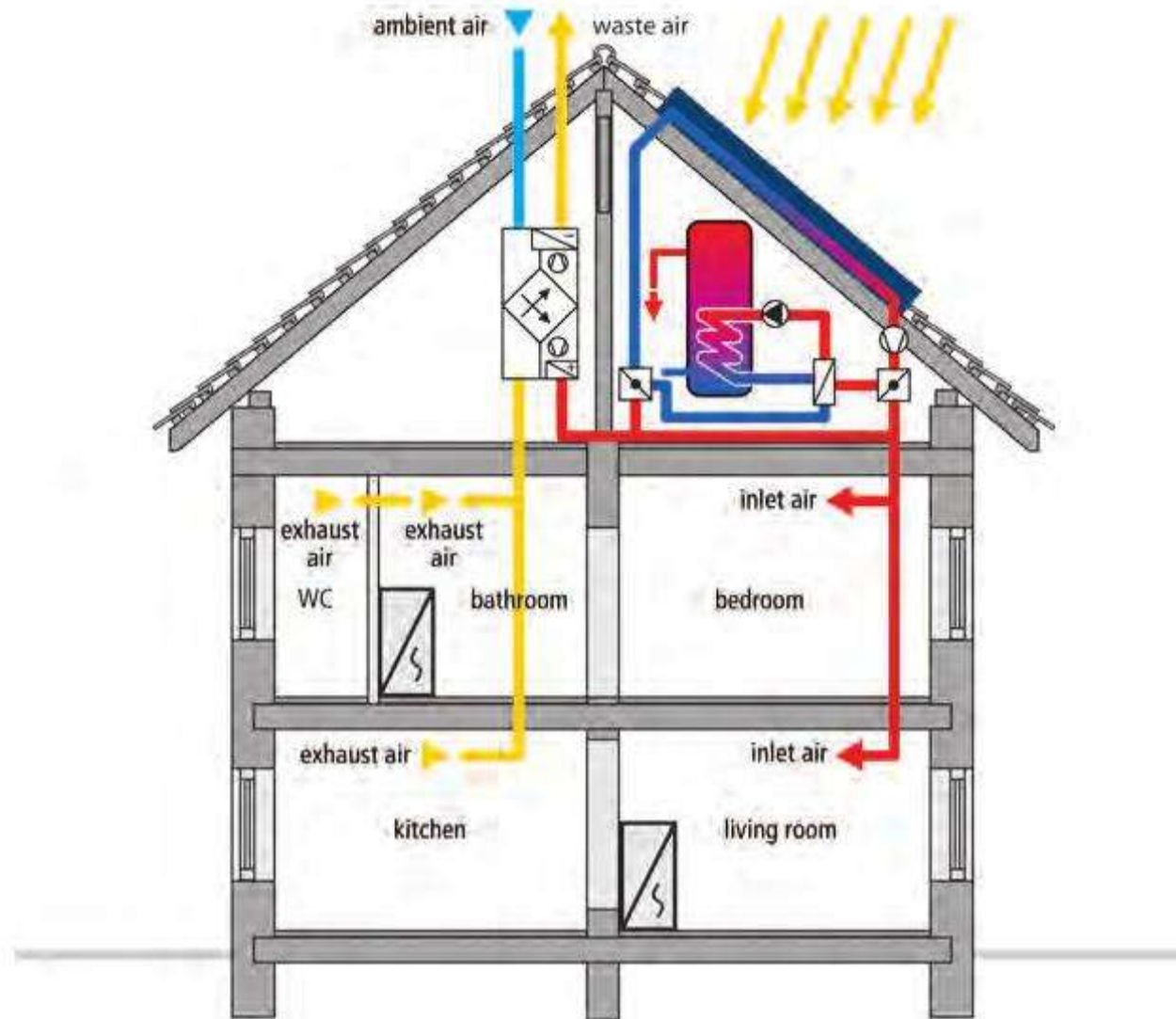

Figure 8.22. Basic diagram of a solar air system with heat recovery (heat pump) and domestic water heating

8.3.4 Solar drying

The intensified use of solar air systems in German-speaking countries began in the 1970s – not within the area of building space heating, but in the area of solar biomass drying. Here there are numerous application possibilities, of which some will be described here in brief.

The solar drying can for example be applied to fruits, vegetables and herbs; for the solar-air drying process of biofuels (e.g. woodchips) or for the drying process of sludge. Usually, the inlet air is heated up by solar radiation and delivered to the biomass as needed. The biomass is either stored in a fixed tank or is fed constantly (on conveyor belts or creepers for example) through the drying chamber. With biofuels or sludge it is crucial that sufficient hot air flows through the medium so that the moisture is effectively absorbed and removed by the air.

Within the area of solar drying processes there are pure supply air systems and combined supply/circulating air systems available. With drying processes, which have to maintain a specific dwell time of biomass inside the drying plant and thus cannot continuously support pure solar drying, appropriate conventional heating facilities need to be ensured. This can be waste heat from a CHP unit or other sources of air heating.

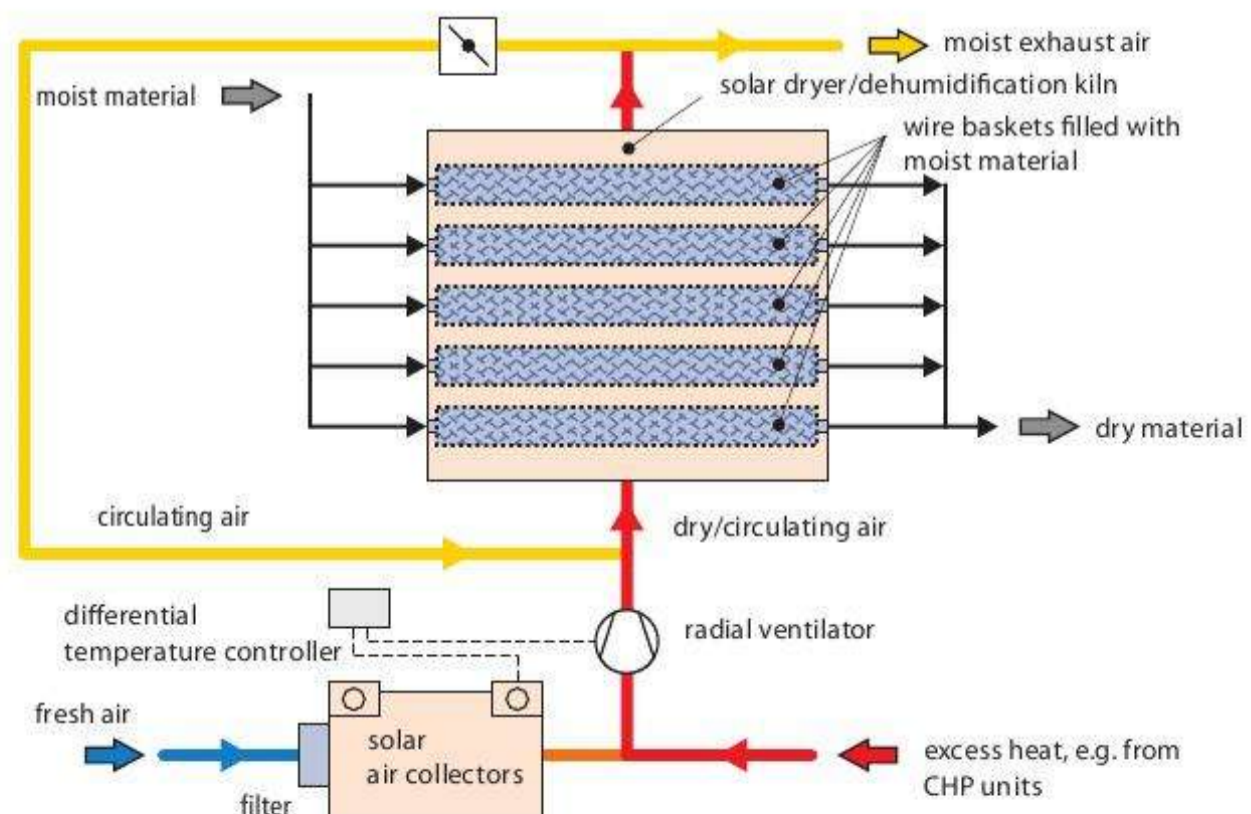

Figure 8.23. Solar drying of moist materials with the use of circulating air and bivalent heat source

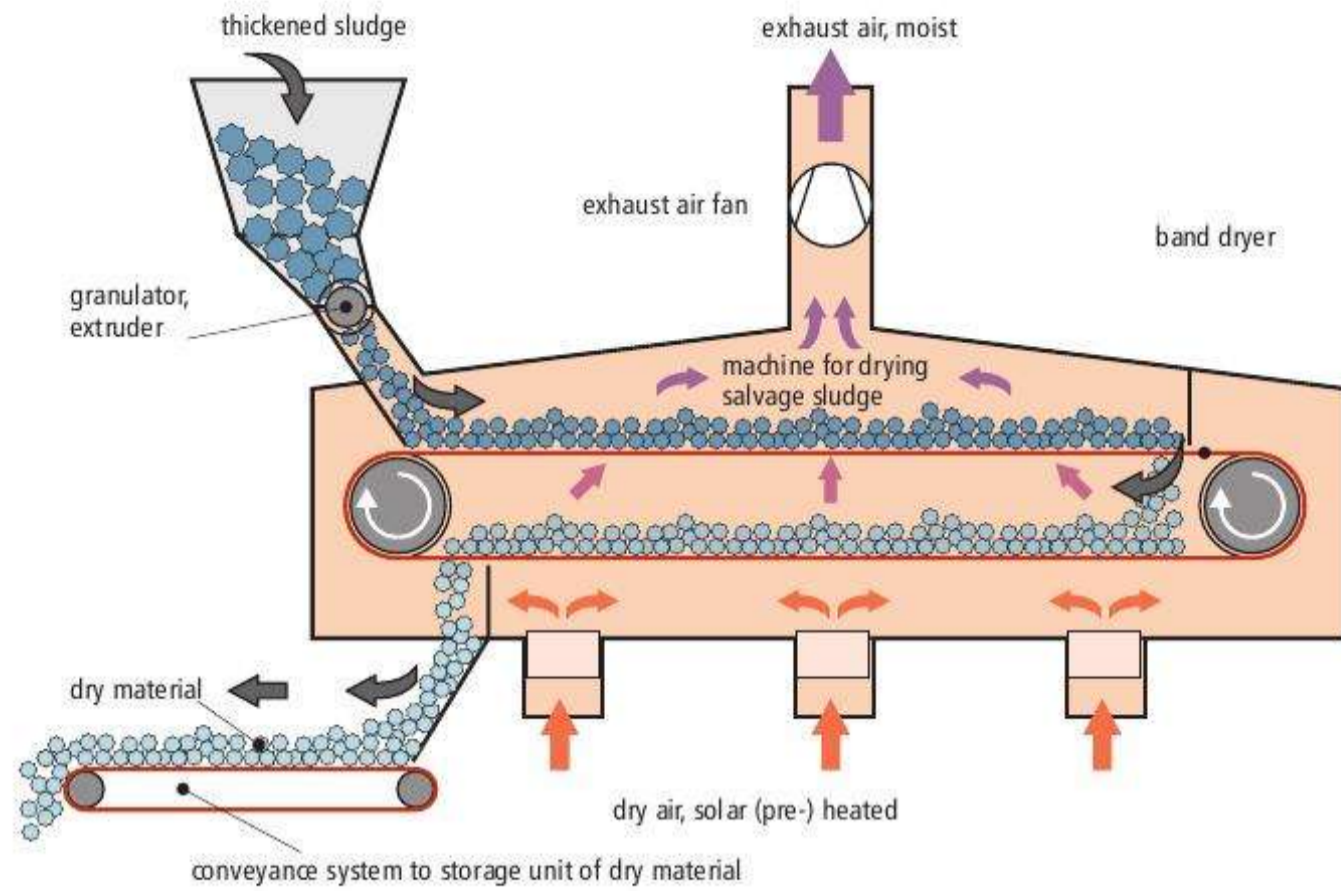

Figure 8.24. Solar drying of biomass with (pre-) heated air

The belt dryer is characterized by a gentle and continuous drying process of sludge throughput performance and operates according to the principle of convection drying

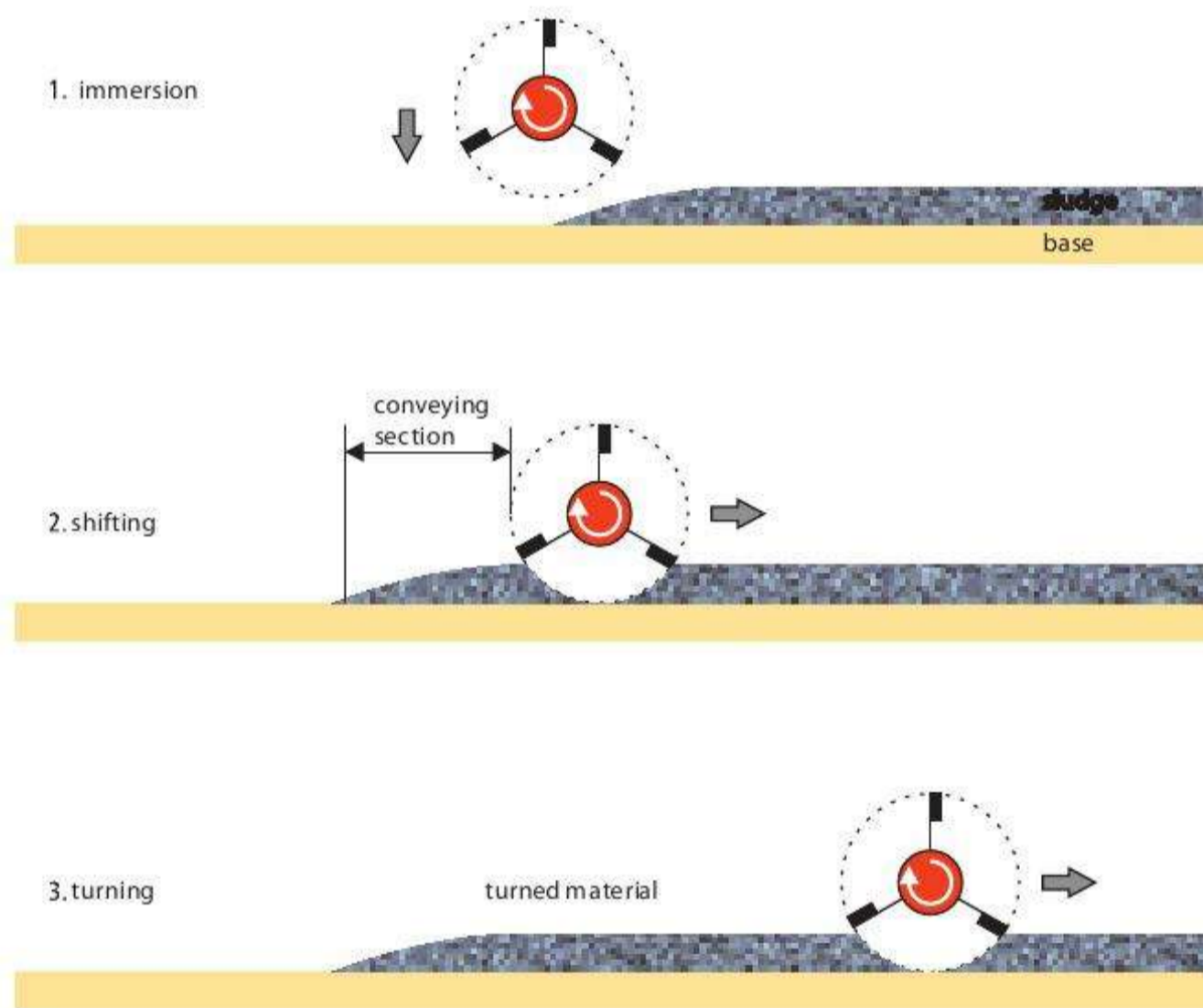

Figure 8.25. Solar radiation drying of biomass with shifting and turning

A further version of the solar drying process is the direct solar radiation dryer. Here, air heating takes place in an ordinary greenhouse, in which the air movement is supported by exhaust shafts and axial fans. Further, the biomass to be dried is continuously turned and conveyed at the same time. The turning supports the drying process, while the conveyance facilitates inserting and removing the biomass before and after the solar drying process.

8.3.5 Factories, halls and office buildings

For factory and office buildings the integration of solar air systems is an interesting and inexpensive application. Here controlled air feed and return lines are already available in many cases. In addition, the heat is required at the same time as the solar radiation is available, as the buildings are generally only used during the day. As a

result the solar air system can be easily installed. This is particularly true for new buildings, in which the large collector surface areas required can replace part of the building shell if integrated into the roof or façades. The additional costs for the solar system can be reduced by setting them against the savings.

Such systems can be used in numerous applications such as sports halls, indoor pools, warehouse and factory buildings, supermarkets, office buildings and schools; an example is shown in Figure 8.26. A particularly promising application for solar air collector technology is that of indoor swimming pools. Here there is an almost full-year requirement for heating energy, with a simultaneous need for large air exchange rates for hygiene reasons.

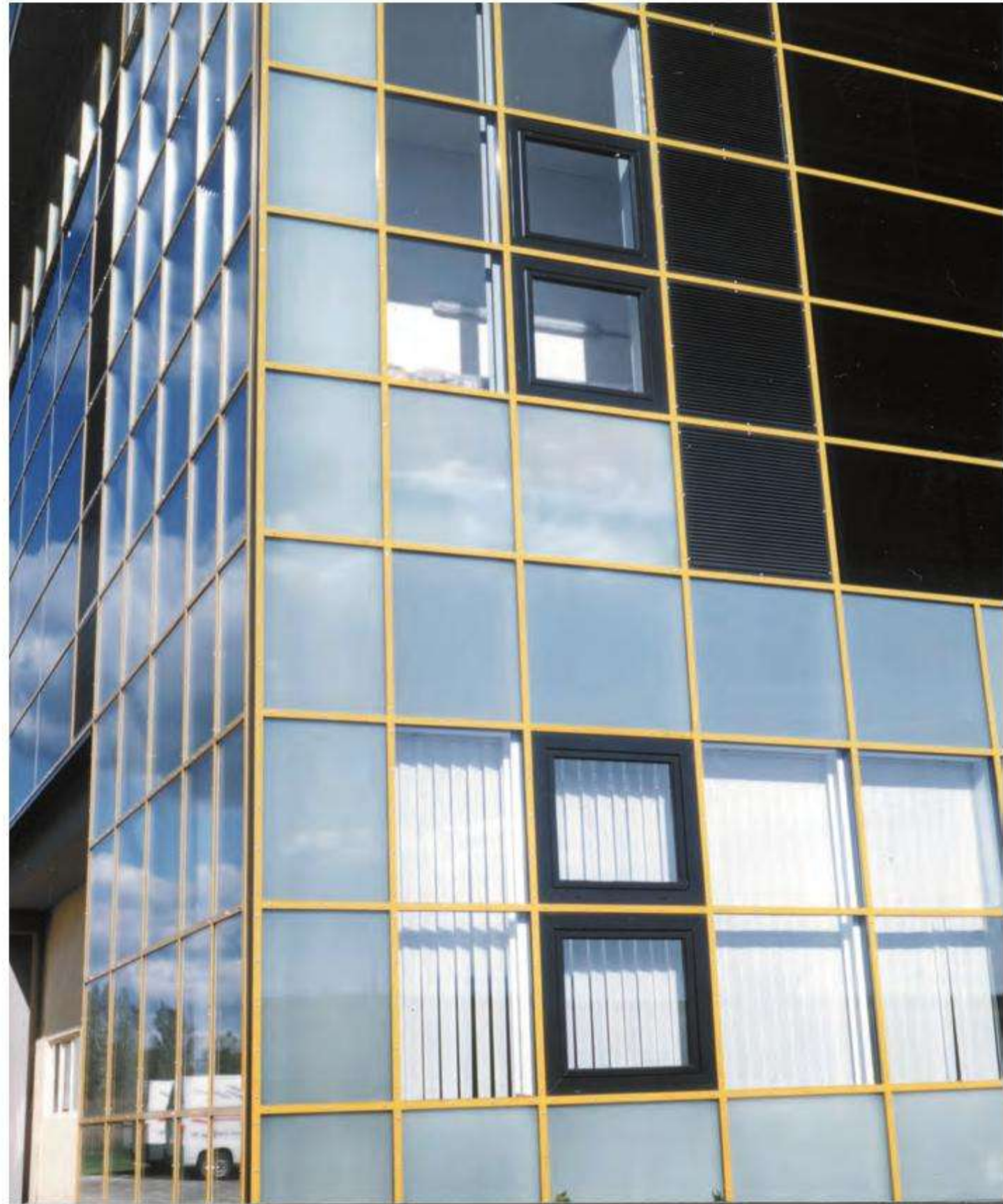

Figure 8.26.
Solar air system in the 'Märkischer
Polstermarkt' (furniture store) with
partial façade substitution (south and
west façades).
Source: Grammer, Amberg

The system construction is similar in principle to the small systems in dwelling houses. Because of the size of the collector surface area it is essential to ensure an adequate circuit arrangement for the collector and collector field circuits to maintain the optimum airflow through the collectors. Rows of collectors connected in parallel have been found to be advantageous. The shortest possible pipe routes should be aimed for between the rooms and the collector field.

The airflow and the size of the collector surface depend primarily on the requirements of the building (see section 8.4). Surface- or personnel-related air change rates are specified according to the type of use. With respect to the surface area (surface area = useful area) this can be between 3 and 20 m³/m²h (9.8 and 65.6 ft³/ft²/h).

8.4 Planning and dimensioning

8.4.1 Fundamental considerations

The design of solar air systems is heavily dependent on the type of application. For plain inlet air systems in holiday homes and also for a system integrated in a ventilation system, an approximate dimensioning for buildings can be carried out with simple rules of thumb: Indicate the amount of required collector area per heated living and building space as a function of low insulation (old building, plain holiday homes) and good insulation standard (low energy house):

1 m² Collector surface area per 10 m² → low insulation standard
 0.75 m² Collector surface area per 10 m² → good insulation

For the integration of the solar air system in the ventilation of dwellings, the area of the collector surface is determined by the airflow requirements of the ventilation, depending on where the air collectors will be installed. If the solar air system is connected upstream of the ventilation, the volumetric flow of ambient air should be considered, because this can alternatively be led through the solar air collectors. If the solar air system is connected downstream of the ventilation system and heat recovery is used, circulated air stream can be added to the ambient air flow rate, so that then the supply air stream (ambient air + circulated air) must be regarded as the relevant variable for the design of the solar air system.

The minimum flow rate of outside air can be obtained from DIN 1946 Part 2. It depends on the type and utilization of the building. For living spaces Part 6 of the rule applies. Laboratory spaces and indoor swimming pools are described in their own sections of the standard or in their own standards. The ventilation requirements can be determined according to person or surface. For dwellings it is always surface-related and is divided into three different groups, which are dependent on the dwelling size.

Table 8.3.
Person and surface-related outside
air flow rate according to DIN 1946
Part 2

	Examples	Ventilation requirement per person	Ventilation requirement per m ²	Comment
Work spaces	Single office	40 m ³ /h	4 m ³ /h	Compare with workplace guidelines
	Open plan office	60 m ³ /h	6 m ³ /h	
	Laboratory	–	–	Reference to DIN 1946 Part 7
Assembly places	Concert hall, theatre, conference room	20 m ³ /h	10-20 m ³ /h	
Living room	Group I, II, III	60-80 m ³ /h	–	Reference to DIN 1946 Part 6
Classrooms	Reading hall	20 m ³ /h	12 m ³ /h	
	Class- and seminar rooms	30 m ³ /h	15 m ³ /h	
Public spaces	Sales area	20 m ³ /h	3-12 m ³ /h	
	Restaurant	30 m ³ /h	8 m ³ /h	
Sports facilities	Sports hall	–	–	Reference to DIN 18032
	Swimming pool	–	–	Reference to VDI 2089

After the airflow rate which is to flow through the solar air system is defined, the sizing of the air collector surface area is the next step. Usually, the ambient airflow rate defines the air collector surface, when taken together with the flow rate suitable for the specific collector (dependent on the desired nominal temperature).

$$A_{\text{coll}} = V / v_{\text{coll}}$$

where A_{coll} is the collector surface area [m²], V the inlet/ambient air flow rate [m³/h], and v_{coll} the specific collector flow rate [m³/(m² · h)]

Section 8.2.1.5 illustrates the dependency of efficiency on the specific collector mass flow. For conversion to the flow rate, the mass flow is divided by the density $\rho = 1185 \text{ kg/m}^3$. In the following example a design is shown for a solar air collector system for an assembly hanger.

8.4.2 Calculation of the outside airflow rate, necessary collector surface and interconnecton of the collectors

Example:

The assembly hanger possesses a surface area of 1087 m² (27 m × 40.25 m) and a height of 4.2 m. The recommended change rate of air for an assembly hanger is 5-to-7-fold exchange of the entire air volume of the hanger every hour. In our example we want the air volume exchanged five times per hour. From these specifications the outside airflow rate is calculated as:

$$V_{\text{supply}} = V_{\text{space vol}} \cdot n$$

where V_{supply} is the outside airflow rate [m³/h], $V_{\text{space vol}}$ is the space volume [m³], and n is the number of air exchanges [h⁻¹]

$$V_{\text{supply}} = 4560 \text{ m}^3 \times 5 \text{ (h}^{-1}\text{)} = 22,800 \text{ m}^3/\text{h}$$

Furthermore, the manufacturer recommends a specific volumetric flow of 60 m³/h per square meter of collector surface. This results in a maximum temperature increase of about 35 K. The required air collector surface area we wish to calculate can now be obtained from the ventilation requirement and the specific volumetric flow:

$$A_{\text{coll}} = V_{\text{supply}} / v_{\text{coll}}$$

OR:

$$\text{Collector surface area (m}^2\text{)} = \text{Ventilation requirement (m}^3\text{/h)} / \text{Specific volumetric flow of collector (m}^3\text{/m}^2\text{h)}$$

From this we obtain a collector surface of:

$$A_{\text{coll}} = [22,800 \text{ m}^3/\text{h}] / [60 \text{ m}^3/(\text{m}^2 \cdot \text{h})] = \text{approx. } 380 \text{ m}^2$$

The flow speed across the free-flow cross-section of the absorber should be between 2 m/s (for thermal reasons) and a maximum of 7 m/s (for dynamic reasons). The free-flow cross-section can be found in the product literature of the collector manufacturer.

The minimum and maximum number of collectors connected in series is:

$$A_{\text{min}} = A_{\text{O}} \times v_{\text{min}} / v_{\text{tot}}$$

where A_{O} is the free-flow cross-section of the collector [m²], $v_{\text{min/max}}$ is minimum or maximum flow speed [m/s], and v_{tot} is the specific volumetric airflow of collector [m³/(m²h)].

The free-flow cross section is the product of the height and width of a flow channel in the absorber. In our example $A_{\text{O}} = 0.96 \text{ m} \times 0.095 \text{ m} = 0.0912 \text{ m}^2$. Thus the minimum area of collector surface connected in series can be calculated as:

$$A_{\text{min}} = [0.0912 \text{ m}^2 \cdot 2 \text{ m/s} \cdot 3600 \text{ s/h}] / [60 \text{ m}^3/(\text{m}^2 \cdot \text{h})] = 11 \text{ m}^2$$

For the highest permitted collector surface area connected in series, it is necessary to use the maximum flow speed v_{max} :

$$A_{\text{max}} = [0.0912 \text{ m}^2 \cdot 7 \text{ m/s} \cdot 3600 \text{ s/h}] / [60 \text{ m}^3/(\text{m}^2 \cdot \text{h})] = 38 \text{ m}^2$$

These results establish the arrangement of the collector modules within a collector field. The principle of uniform flow through individual legs by means of the circuit arrangement according to the Tichelmann principle must be observed (that is, the pressure loss of each collector or each row of collectors is the same).

Example:

In our example, for the required collector surface area of 380 m² at a module size of 2.4 m² about 160 collectors must be interconnected in rows of at least 5 (5 · 2.4 m² = 12 m²) and a maximum of 16 (16 · 2.4 m² = 38.4 m²) collectors. With the available roof surface area of 1000 m² and orientation of the short side to the south, a possible solution would be the installation of 16 parallel rows of 10 collectors, whereby mutual shading of the rows of collector must be taken into account.

8.4.3 Calculation of fan power

The calculation of the fan power takes place in accordance with calculations from conventional ventilation technology. In order to overcome the frictional losses that occur throughout the system, a particular *fan power* P_F [W] is required.

Similar to liquid-based systems, determination of fan power requires knowledge of the total pressure losses of the system. These are made up of the pipe friction losses in the absorber channels, the inlets and outlets to the rows of collectors, the pipe bends and the pipelines themselves. Values for the pressure losses, depending on the volumetric flow and the flow speed for the individual components, can be found from the manufacturer's nomographs.

In our example this results in a total pressure loss of 272 Pa (1 Pa = 1 Ws/m³).

Table 8.4.
Example of calculation of pressure loss in (solar) air system

Component	Individual pressure loss	Qty/piece quantity	Pressure loss (Pa)
Pipeline	1 Pa/m	~60 m	60
Inlets and outlets	9.5 Pa	2	19 Pa
Pipe bends	13 Pa/piece	6	78 Pa
Collector in series connected collectors	4.3 Pa/m	10 × 2.5 = 25 m	115 Pa
			Total 272 Pa

The fan power P_F (W) can then be calculated as follows:

$$P_V = v_V \times \Delta p_{\text{tot}} / \eta_{\text{fan}}$$

where v_V is the hourly ventilation requirement (m³/h), Δp_{tot} is the total pressure loss (Pa), and η_{fan} is the efficiency of the fan.

Dependent on the type of fan, the propulsion efficiency η_{prop} must be added to the fan power.

Example

By assuming a fan efficiency of 0.7 the fan power can then be calculated as:

$$P_F = [22,800 \text{ m}^3/\text{h} \cdot 272 \text{ Ws/m}^3] / [0.7 \cdot 3600 \text{ s/h}] = 2460 \text{ W}$$

8.4.4 Dimensioning of an air-to-water heat exchanger

The application of an air-to-water heat exchanger, for the use of the solar air systems also in summer, is a suitable solution that allows the solar air system to operate highly efficiently over the whole year. With the sizing of the heat exchanger it should be taken into account that the transfer of heat of the medium air to water or to a water-propylene-glycol mixture does not work as optimally as with air-to-air or water-to-water heat exchangers due to the specific thermodynamic parameters. Generally the heat exchanger should be dimensioned in such a way that the maximum amount of energy, which is available in summer, is transferred, but still allowing for preliminary heating of domestic water to take place during average solar radiation. In order to achieve this, the following calculation should be employed to determine the average output of the heat exchanger and the necessary volumetric flow in the solar circuit:

$$Q_{\text{WT L/W average}} = V_L \times c_L \times \Delta T_L$$

where $Q_{\text{WT L/W average}}$ is the average output of the heat exchanger [W], V_L is the hourly volumetric flow of air [m³/h], c_L is the specific heat capacity of air [0.293 Wh/m³ · K for 35°C], and ΔT_L is the temperature difference downstream [K].

The temperature difference in the solar air system can be assumed here, for example with 20K, resulting in approximately 55°C inlet temperature at the heat exchanger and 35°C outlet temperature. The volumetric airflow should be lowered to for example, 40 m³/m²h in relation to the heating operation, in order to achieve higher temperatures.

Hence, in the case of a typical system in a single-family house with 10m² collector surface area, there results a total volumetric flow of 400 m³/h, and so the average heat exchange performance is:

$$V_w = Q_{WT L/W \text{ average}} / (c_w \cdot \Delta T_w)$$

where $Q_{WT L/W \text{ average}}$ is the average output of the heat exchanger [W], V_w is the volumetric flow in the hydraulic system [m³/h], c_w is the specific heat capacity of water [1150 Wh/(m³ × K)], and ΔT_w is the water-side temperature difference [K].

$$V_w = 2344 \text{ W} / 1150 \text{ Wh}/(\text{m}^3 \cdot \text{K}) \cdot 10 \text{ K} = 200 \text{ l/h}$$

The max. heat exchanger performance can be calculated with the adjusted max. inlet temperature of approx. 80°C, thus a ΔT_L of approx. 35 K.

When planning a solar air system, and the possibility of domestic water heating is intended from the beginning, the collector surface should be approx. 15 to 25% larger laid out compared to an ordinary heating operation.

8.4.5 Computer-assisted system sizing

A simulation of air collector systems is possible with the programs Luftikuss, SWIFT and TRNSAIR.

LUFTIKUSS

In the Windows Program Luftikuss buildings are displayed with a static one-zone model. During the input of data the operating mode of the collector (outside-, mixed- and circulated air), the specific collector throughput, the outside air change rate, the lifespan of the ventilation system as well as the desired room temperature can be selected. As a result one receives the solar energy yields, the solar fraction, or for the specification of solar fraction the collector surface area, the annual power requirement of the building for heating and ventilation as well as the energy and CO₂ savings.

In the following a simulation of the preceding example of an air collector system for an assembly hangar is illustrated:

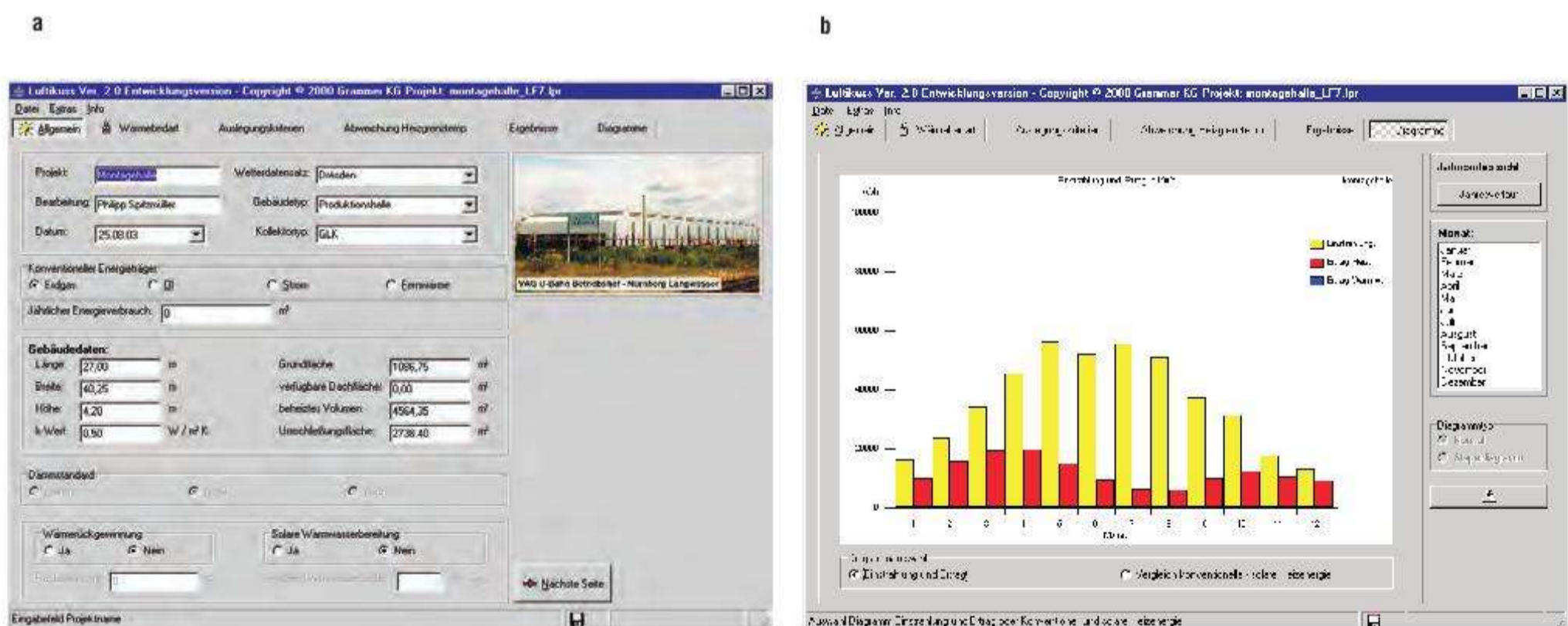

Figure 8.27.
Input form and result diagram of
the simulator routine Luftikuss
(Manufacturers: Grammer
Solar GmbH, Amberg)

The determined collector surface area of 380 m² achieves a heat performance of 311 kW_{peak} with an annual consumption index of approx. 30% and a solar fraction of likewise 30%.

SWIFT

For the façade-integrated collectors of the type Solarwall a proprietary program exists, with which the yield of the collectors and the calorific loss can be calculated for the Solarwall façade. It is called SWIFT, is available as a Windows version and came on the market in 1999.

TRNSAIR

The program TRNSAIR, which is based on the simulation environment TRNSYS, computes with a two-zone building model and the six types of solar air systems that were defined within the framework of the IEA-Task 19.

Further programs were investigated that exclusively carry out ventilation simulations for buildings and in which air collectors are not integrated. The physical characteristics of air collectors can, however, be fed into the programs.

8.5 Installation

8.5.1 Collector installation

In describing the different collectors and system variants we have already discussed the possible methods of installation. As for liquid-based solar systems, on-roof and in-roof installation is possible, as well as mounting on stands and integration into façades.

8.5.1.1 ON-ROOF INSTALLATION

PITCHED ROOF

Fixing of the collectors takes place in the same way as for other flat collectors. The collectors are mounted on the roof with roof hooks (rafter anchors), which are led for example through a tiled roof and fixed to the rafters. The collector is then screwed down using rails and fixing straps. Normally two fixing straps are required per collector, with two rafter anchors each. As the collectors are connected to one another directly by means of butt joints, a rigid unit is produced: therefore only one strap is required for a middle collector. Pitched roof installation is used mainly for domestic buildings.

FLAT ROOF

When using solar air systems on halls or factory buildings they are mounted either on the façade or on stands on the flat roof (Figure 8.28). Here too the installation is similar to that used for normal stand-mounted collectors. Some manufacturers offer a complete installation set of aluminium profiles. This consists of one bearing rail and two further supporting rails, which are screwed together to form a triangle on the bearing rail. If several rows are installed on a roof a grid structure is obtained, as the bearing rails of the different rows are connected together. The underside of the rails are coated with a closed-cell foam material, which prevents damage to the roof skin and simultaneously



Figure 8.28.
Stand-mounted solar air system on the roof of a hall. Source: Grammer, Amberg

ensures uniform load distribution. The collectors are mounted on the aluminium rails with screws, and hence take up the inclination angle of (normally) 45° . Between the collectors in the rows a silicon bead is applied for sealing purposes and to prevent the ingress of moisture. According to the manufacturer's information, an additional roof load from the collectors of about $13\text{--}15\text{ kg/m}^2$ ($3.7\text{--}3.1\text{ lb/ft}^2$) can be expected with this system, which should not lead to any structural problems on most roofs.

8.5.1.2 IN-ROOF INSTALLATION

Optimum roof integration can be achieved by means of the modular design of the collectors.

VARIANT 1

The collectors can be mounted on the roof boarding or lathing (Figure 8.29). The air collectors are screwed to the roof boards through the sheet metal trough. The collectors are connected to each other with sheet metal collars. A wooden frame is erected around the collector field. A sealing strip and a lead sheet apron create the sealed transition between collector and roof surface. The glazing bars are screwed to the surrounding wooden frame or to the butt joints between two collectors. Additional retaining brackets are installed at the bottom side, which should prevent slipping of the glass cover. The glazing bars are fitted with a rubber profile strip after the glass has been fitted.

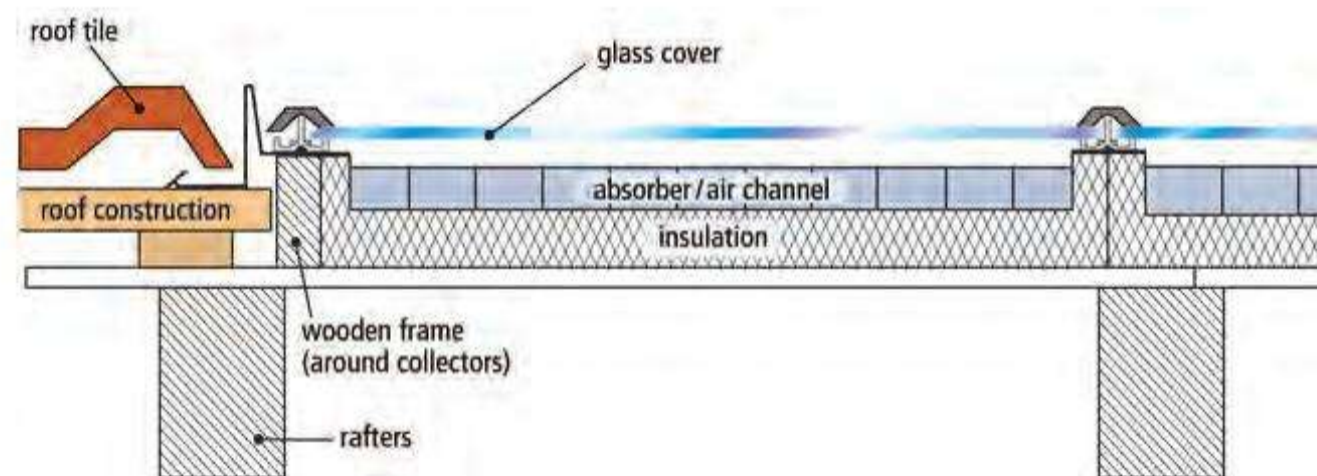

Figure 8.29.
In-roof collector installation on the roof rafters

VARIANT 2

The collector troughs can also be installed between the rafters (Figure 8.30). The wooden frame around the collector field can be dispensed with, and the glazing bars are mounted directly on the rafters. Around the edge of the collector field a rain-proof transition to the roof surface is still necessary. This variant has a much lower height.

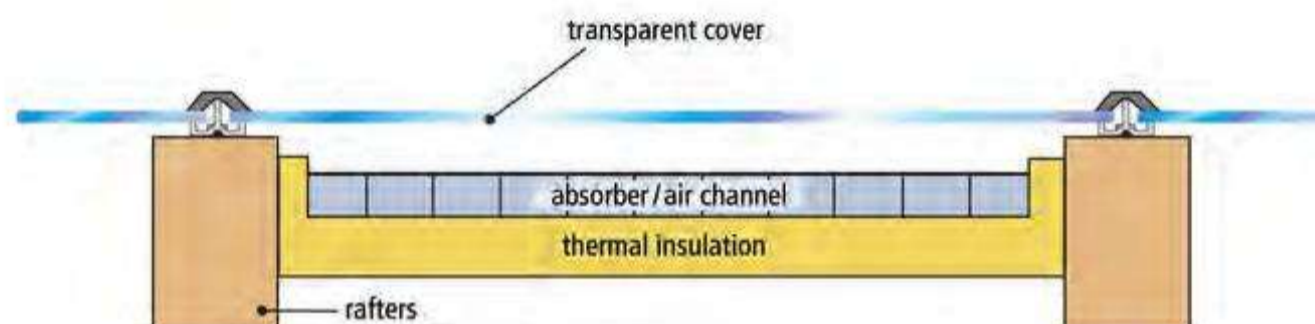

Figure 8.30.
In-roof collector installation between the rafters

8.5.1.3 FAÇADE INTEGRATION

The mounting of collectors within a façade-integrated solar system depends mainly on the solar air system being used, as well as on the degree of building shell substitution.

One example is the *Grammer system*, in which the collectors replace only part of the building shell and are placed, for example, on a concrete façade. In another possibility the collectors are integrated into the post-beam or steel frame construction of the façade, and the whole surface area is covered by glass. The collectors used here are not standard collectors, but are made according to the building requirements. The butt joints of the collectors are designed so that they can be optimally bedded into the post-beam construction. Owing to the good thermal properties of the collectors they simultaneously serve as thermal insulators for the building. In a market building a k -value of $0.5\text{ W/m}^2\text{K}$ was achieved for the collector.

The *façade absorber system* made by Solarwall is installed in mass-produced sizes onto existing building walls. In the case of larger systems the trapezoidal absorber sheeting is mounted on, for example, double T-sections. A back-ventilated absorber façade is thus created. The absorber sheet can be made and mounted in lengths of up

to 16 m (52.5 ft) without joints. On the upper side the collectors have an intake nozzle with a diameter of 100 mm (3.9 inches). The corresponding collector pipes or boxes, which distribute the solar-heated air into the building, are fitted to these nozzles. In the summer the absorber can be bypassed through an additional opening to avoid overheating in the ventilated rooms, and to maintain proper ventilation.

The Solarwall column collector can be used in dwellings and office buildings. It is a 1 m (3.3 ft) wide element with defined closures on the sides, which can be mounted in lengths of up to 16 m (52.5 ft) in façades between rows of windows, for example. It can also be integrated into a roof if it has a pitch of at least 20° (Figure 8.31).

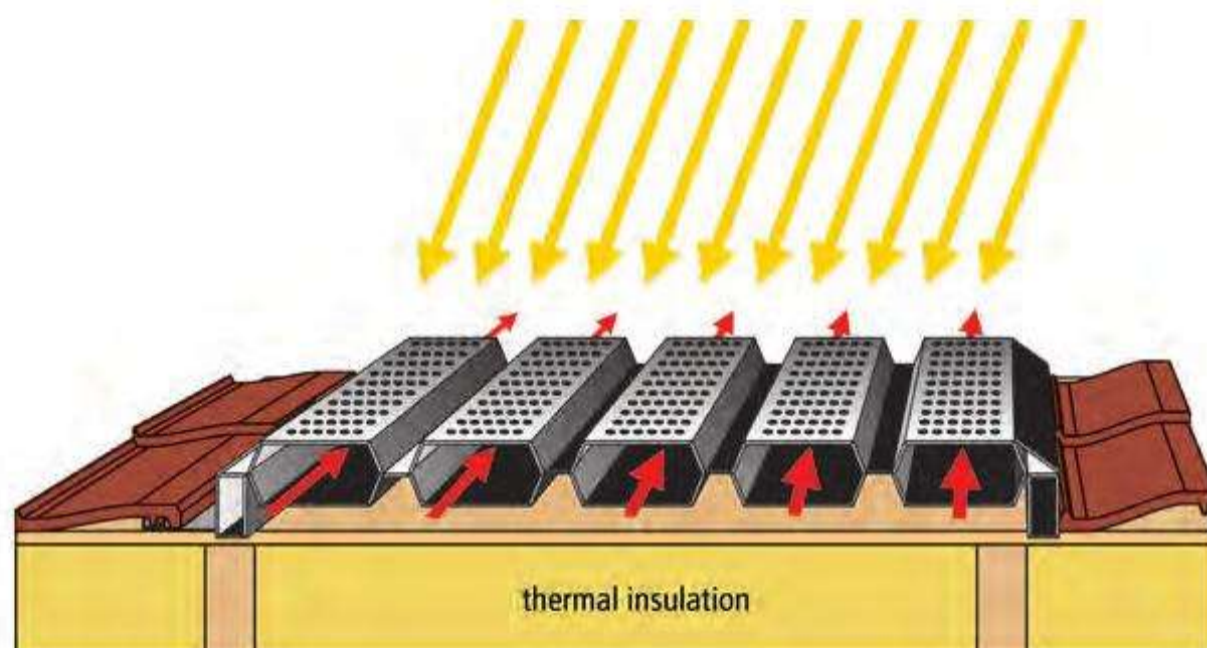

Figure 8.31.
Diagram of a roof-integrated Solarwall
column collector

8.5.2 Installation of pipelines

The main principle for the installation of the piping is to choose the shortest possible routes between the rooms to be heated and the collector field. Because of the large dimensions of the lines, careful planning is thus essential to achieve this aim. The wrapped spiral-seam tube and the necessary shaped parts are fixed together with nipples and sleeve connectors. Wall and ceiling breakthroughs are made with a plastic collar piece. Where necessary the lines are attached to the wall or ceiling with anchor clamps. In principle, for aesthetic reasons, it is preferable to integrate visible installation parts into walls or ceilings, though this is possible only in certain cases because of the large pipe cross-sections.

8.5.3 Positioning of the fan

When installing the fan, a suitable position should be chosen. To prevent energy losses from unavoidable leakage at the pipe connections, the solar air system should be operated at low pressure. At the same time the fan should be at a sufficient distance from the rooms to avoid noise disturbance.

If a heat recovery unit is used, this must be installed as centrally as possible and without vibration. Short connecting routes should also be used here.

8.6 Costs and yields

The average cost of an air collector without assembly, installation and VAT, with respect to the absorber surface area, is approximately €250–300/\$250–300/£175–210 per m². The average costs for façade air collectors or Solarwall façade collectors, depending on the wall/roof construction and the desired airflow rate, are about the same level as for comparable façade structures. Of course the complete installation may be much more expensive, depending on the complexity, heat exchangers etc.

Information on system efficiency is not meaningful collectively for air collector systems, as there are no average values for the thermal load that can be compared with the values for hot water consumption. The system efficiency and hence the specific yield of an air collector system are strongly dependent on the type of application:

- system efficiency up to about 30%: air collectors to supplement a ventilation system with heat recovery (priority switching for heat recovery)
- system efficiency > 30%: similar, but with use of excess energy for domestic water heating
- system efficiency up to 65%: fresh air preheating for an indoor swimming pool; drying of wood chippings.

8.7 Examples

8.7.1 Domestic building, Potsdam, Germany

This slim 16-storey block of flats in the centre of Potsdam was subjected to basic restoration in 2000. Thermal insulation was improved, and the sanitary installation was renewed. Controlled feed and return air ventilation with heat recovery was installed in the bathrooms of each of the 93 flats. The old windows were also replaced by modern well-insulated windows. The slim south façade, in which only the windows for the landings are installed, was partially equipped with air collectors (Figure 8.32).

To the left and right of the windows, two rows of 2×15 series-connected collectors of type G LK 3M from Grammer, Amberg have now been installed. The 60 collectors provide a total collector surface area of 150 m^2 (1615 ft^2). The air collectors transfer their heat to the ventilation system. In the summer months, or if for other reasons heating of the bathrooms is no longer necessary, the solar air system is switched over to domestic water heating.



Figure 8.32.
Solar air system at Breite Strasse,
Potsdam. Source: DGS

The solar air system preheats the room air in the bathrooms of the building. This is achieved by two central ventilation systems installed in the plinth. The collector system is also divided into two pieces; two parallel rows operate respectively on a central ventilation system. Two storage tanks of 1000 l (264 gallons) each are installed for domestic water support in the summer months. Conventional domestic water heating takes place in a through-flow system via the domestic substation, which supplies all the other rooms with heat.

Control of each of the two parallel collector fields takes place by means of a temperature difference controller for twin storage tank systems. Bathroom heating has the priority. When the maximum temperature is reached, the system switches over and charges the domestic water storage tank. A maximum temperature limit (80°C; 176°F) is also set here, at which the fans switch off.

Some system data:

- Location: Potsdam
- Collector surface area: 150 m²(1615 ft²)
- Alignment: Inclination 90°, azimuth 0°
- Commissioned: 2000
- Volumetric flow: 3400 m³/h (120,070 ft³/h)
- Power: 100 kW_{peak}
- Solar planning: PAi-PLAN GmbH, Potsdam; Grammer KG, Amberg
- Installation: Frohberg
- Yield: 65,076 kW/a
- Solar fraction: heating 56%; hot water: 37%
- CO₂ savings: 6749 kg/a (14,879 lb/a).

8.7.2 Solarwall on General Motors building in Ontario

Solarwall cladding was installed in 1991 at a General Motors lead–acid battery plant in Oshawa, Ontario (Figure 8.33). The product, trademarked Solarwall[®], performs like a solar panel, but looks like a conventional metal wall. The system provides heated ventilation air for the plant. It operates by drawing air through a large number of small holes that penetrate the cladding. Heat that is absorbed from the solar radiation falling on the surface is transferred to the air, which then moves upwards behind the wall to an overhanging, enclosed canopy. The system is driven by two ventilation fans installed inside the building, which use the canopy as a manifold, and which distribute the warmed air to the building via ducting.



Figure 8.33
Solar wall on General Motors building in
Ontario. Source: Conserval

The GM Solarwall installation incorporates modifications and improvements from several years of Solarwall testing and development. Total energy savings result from four different mechanisms:

- active solar heating of ventilation air
- recapture of heat flowing out through the south building wall
- reduction of conduction through the south wall due to increased local air temperature
- destratification of building interior air.

The solar collector consists of black aluminium wall cladding 6.25 m (20.5 ft) high. Holes 1.6 mm (0.06 inches) in diameter cover 2% of the surface. The collector is fastened vertically to the south building wall, leaving a 150 mm (5.9 inches) airspace behind. The enclosed canopy overhangs the top of the cladding by 0.9 m (2.95 ft). The effective collector area is 420 m² (4521 ft²).

The system uses two high-efficiency fans, designed to supply a total airflow of 20,750 l/s (5482 gallons/s). The solar-heated air is mixed with recirculated air, and distributed through 122 m (400 ft) of fabric duct. The mix of fresh and recirculated air is controlled automatically to provide a preset air temperature.

Based on 1993–94 monitoring results, the GM Solarwall delivers 455 kWh/m² of solar energy per year. Additional savings provided by the Solarwall amount to 300 kWh/m² annually, for a total annual contribution of 755 kWh/m². For the full 420 m² (4521 ft²) collector area, this represents a total contribution of 317 MWh annually.

The installed cost of this system is estimated at C\$92,400 or C\$220/m², including the cost of design modifications. Compared with alternative ventilation air systems, this represents a cost increment of between C\$15,500 and C\$23,200. Depending on the fuel displaced, energy cost savings would be between C\$4700 and C\$12,200 per year, and payback between 1.3 and 4.9 years.

The GM Solarwall installation is providing increased ventilation in the battery plant, resulting in improved indoor air quality. Additional environmental benefits derive from displacement of the conventional ventilation (make-up air) unit that would otherwise be required. This results in reduced emissions from combustion. In the case of a conventional natural gas unit, for instance, the reduction in carbon dioxide releases is estimated at 81 t annually, based on a seasonal efficiency figure of 70% for a gas-fired make-up air unit.

9 Solar cooling

9.1 Introduction

The growing desire for comfort has led in recent years to a considerable worldwide increase in the number of buildings with air-conditioning. This trend can be observed in Europe, and particularly in southern Europe. A similar development can be seen in the automobile industry, where a steadily growing number of cars now have air-conditioning. This is leading to a vast increase in the number of people who are used to living in a climatized environment, and such an environment is also desired and expected at work or at home. Moreover, the results of investigations show that the working capacity of human beings significantly decreases with room temperatures above 24°C (75.2°F).

As the energy consumption of air-conditioning systems is relatively high – and standard refrigeration-based compression systems use electricity – future-oriented solutions for a sustainable energy supply demand renewable energy systems.

Producing cooled air by making use of solar power may seem paradoxical at first sight. Generally, the sun tends to be viewed as a source of heat. However, there exist thermal processes to produce coldness, in which water is cooled or air-conditioning is driven directly by a heat input. These processes are generally suitable for using heat provided by solar thermal collectors as the principal source of energy. Of course, solar radiation can also be converted to solar electricity by photovoltaic systems to drive conventional refrigeration compression systems. However, the latter approach will not be dealt with in the following section, for several reasons:

- In the short term, generating solar electricity in northern and central Europe will be more costly than producing solar thermal heat (exceptions are very small-scale applications, in the range of a few watts up to several hundred watts).
- Although the commonly used refrigerants for compression refrigeration systems generally no longer harm the ozone layer of the atmosphere, they still intensify the greenhouse effect significantly. Compared with CO₂, today's refrigerants could



Figure 9.1.
100 m² collector system for a solar-powered air-conditioning system in Freiburg, Germany. Source: Fraunhofer ISE

potentially boost the greenhouse effect several thousand times over. Thus these refrigerants contribute considerably to the anthropogenic global warming of the atmosphere.

- The refrigerants used in commercially available thermal refrigeration systems contain only substances that do not influence the greenhouse effect. Adsorption- and sorption-based systems just use water as the only refrigerant.

To date, the traditional design of solar thermal collector systems for providing hot water in moderate climate zones such as central Europe has generally been based on the idea that excess heat in summer should be avoided, or at least kept to a minimum. With the systems increasingly deployed in recent years to support heating, a summer excess in principle cannot be avoided. For reasons of economy – the specific collector yield falls with the increasing degree of solar fraction – a larger collector surface is often also rejected, even if this would ultimately be associated with greater environmental relief.

The use of the summer excess heat for solar thermal cooling therefore offers the opportunity to improve the efficiency of solar thermal systems for providing hot water or heating support. Moreover, the new application largely eliminates system shutdowns with the high shutdown temperatures that are a stress on materials. In addition, a promising new application field results for the solar thermal industry. There are also corresponding export opportunities to countries where room air-conditioning is already standard today on account of the climatic conditions.

In this chapter, we repeatedly make a distinction between cooling and air-conditioning. By cooling we mean reducing the temperature, for example in a room or even the temperature of a machine in industrial processes. By air-conditioning, on the other hand, we mean the ‘conditioning’ of rooms in respect of their temperature and humidity properties, so that people in the room feel comfortable. Hence the term ‘air-conditioning’ is drawn wider and comprises, in addition to lowering or raising the room temperature in summer and winter, a reduction or increase in air humidity in the room to comfortable values. Despite this distinction, in industry circles the term *solar cooling* has become entrenched as the umbrella term for talking about solar-driven cooling and air-conditioning. Hence if we say ‘solar cooling’ in this chapter, we mean this general category.

Another argument for solar cooling – diametrically opposed to solar space heating – is the chronological coincidence, in principle, between demand (dissipating the cooling load) and energy supply in the form of solar irradiance. Figure 9.2 illustrates this relationship for central European conditions. It shows the seasonal correspondence between irradiance and cooling load to be dissipated for a seminar room in Perpignan (southern France). It is clear that there is a very good match with cooling requirements. The result is that no large seasonal heat storage facilities are required.

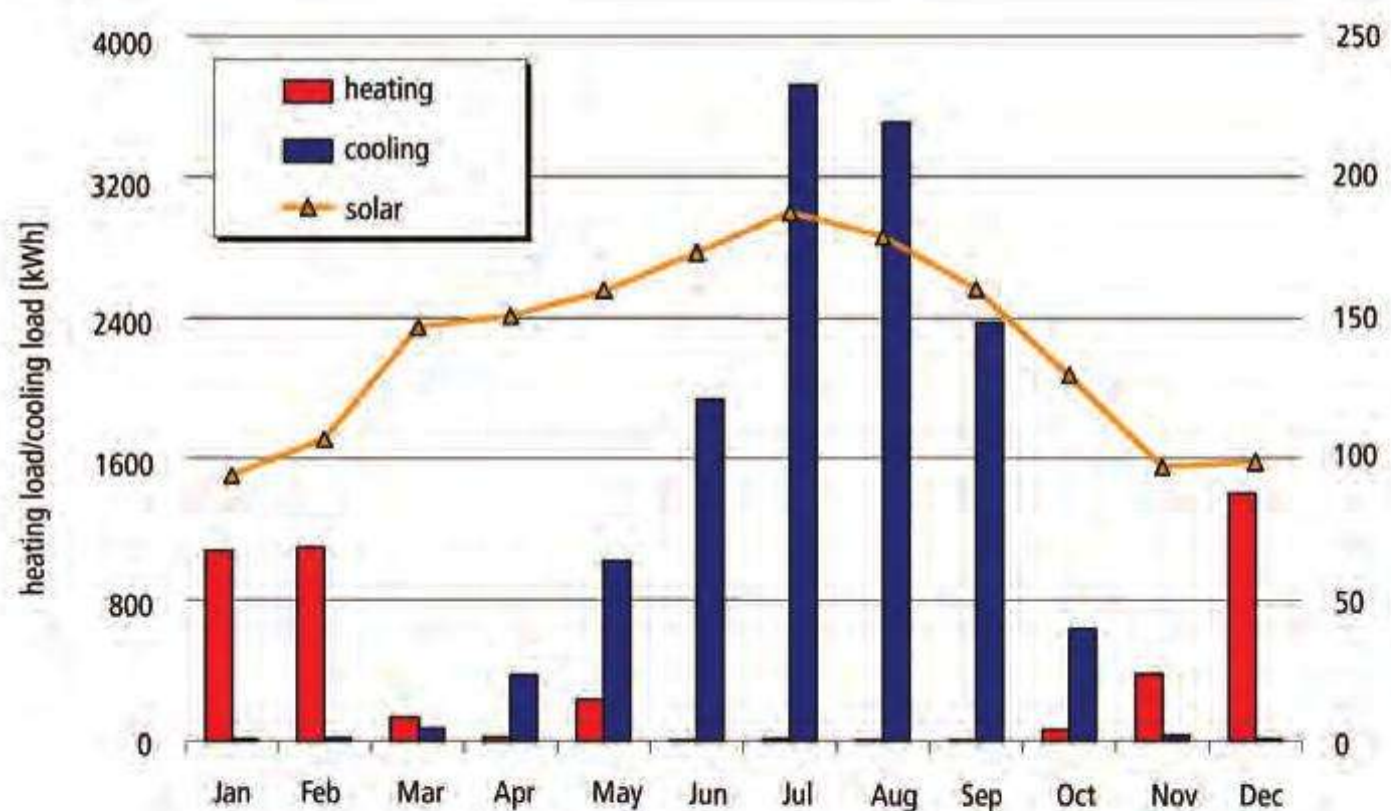

Figure 9.2. Correspondence between solar irradiance and cooling load/heating load for a seminar room in Perpignan (southern France). Source: Fraunhofer ISE

9.2 Theoretical bases

This chapter is intended to give an overview of the processes for solar thermal cooling. It will become apparent that the greatest challenges lie in the system integration of collector installation and cooling technology. As a result, so far there has been a real shortage of planners who are able to plan a solar cooling system from scratch. However, compared with designing a solar thermal system for domestic water heating, the planning task is also much more complicated. The task requires knowledge in very different areas, from building systems to collector technology to cooling systems. In addition, so far there has been very little practical experience with the technology. Some of these systems are presented in this chapter.

9.2.1 Overview of thermally driven cooling processes

Table 9.1 shows the various thermally driven cooling processes. Among the processes available on the market, it is possible to distinguish between the closed absorption and adsorption processes and the open process of desiccant cooling.

Table 9.1.
Overview of thermally driven
cooling technologies

Process	Absorption	Adsorption	Desiccant cooling system
Type of air-Conditioning	Chilled water (e.g. chilled ceilings)	Chilled water (e.g. chilled ceilings)	Air-conditioning (cooling, dehumidification)

In the closed processes, the cooling medium is not in direct contact with the environment. First of all, cold water is produced. This cold water can then be used in chilled ceilings, in concrete core conditioning, or also in the classical way in the air cooler of an air-conditioning system to reduce temperature and/or humidity.

By contrast, in the open process of desiccant cooling the cooling medium (water) comes into direct contact with the air being conditioned. The cooling and dehumidification functions are directly integrated into the air-conditioning system. This is why one frequently also encounters the term *air-conditioning without refrigeration*.

9.2.2 Absorption cooling

Absorption chillers (AbCh) differ from compression chillers in that they use a thermal compressor instead of a mechanical one. Figure 9.3 shows a schematic diagram of a system of this type.

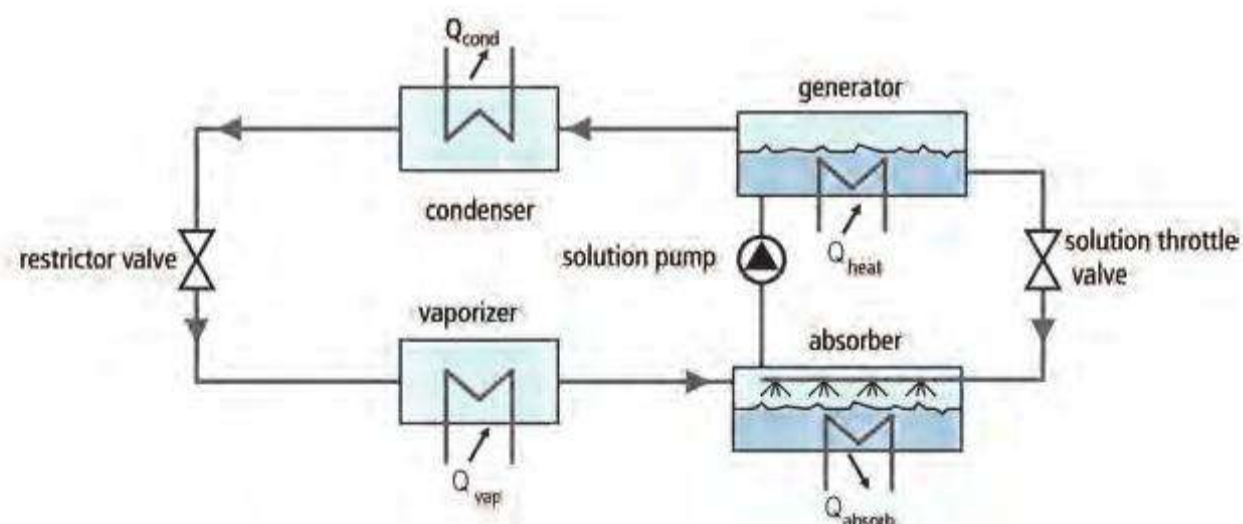

Figure 9.3.
Diagram of an absorption chiller¹⁶

The condenser, cooling medium restrictor valve and vaporizer form the cooling part of the system, through which only the cooling medium flows. The thermal compressor comprises absorber, solution pump, generator and solution throttle valve, constituting the driving part of the system.

The cooling part of the AbCh is no different from a conventional compression chiller. The necessary compression of the cooling medium to the condenser pressure is performed by the thermal compressor. The vaporized cooling medium flows into the absorber, where it is absorbed by the solvent. The released absorption enthalpy must be dissipated, as the absorption capacity of the solvent decreases as the temperature rises. The absorption process enriches the absorption medium with cooling medium. The rich solution is pumped using the solution pump to the generator (also known as a de-aerator or boiler). Here, by supplying thermal heat, the cooling medium is

separated from the solvent and the two-substance mixture becomes depleted of cooling medium. The depleted solvent is depressurized in the solution throttle valve to the absorber pressure, where it is once again atomized in order to absorb the cooling medium.

Apart from the electrical power requirements of the solution pump, the AbCh is driven only by thermal energy. However, the energy requirement of the solution pump is very low, with approximately 0.5–2% of the refrigerating capacity achieved in the vaporizer. The efficiency of the AbCh shown in Figure 9.3 is usually improved by installing a solvent heat exchanger. This is arranged so that the rich, cold solution after the absorber and the warm, depleted solution after the generator flow in opposite directions through the heat exchanger. This makes possible savings on thermal heat in the generator and on cooling water in the absorber.

9.2.3 Adsorption cooling

Currently only two Japanese manufacturers of adsorption chillers (AdCh) are known on the market. Their systems are very similar in design. The physical process is identical in both chillers. The description of the function and the design is taken from the technical documentation of GBU⁴⁷. Figure 9.4 shows the schematic structure of a low-temperature AdCh.

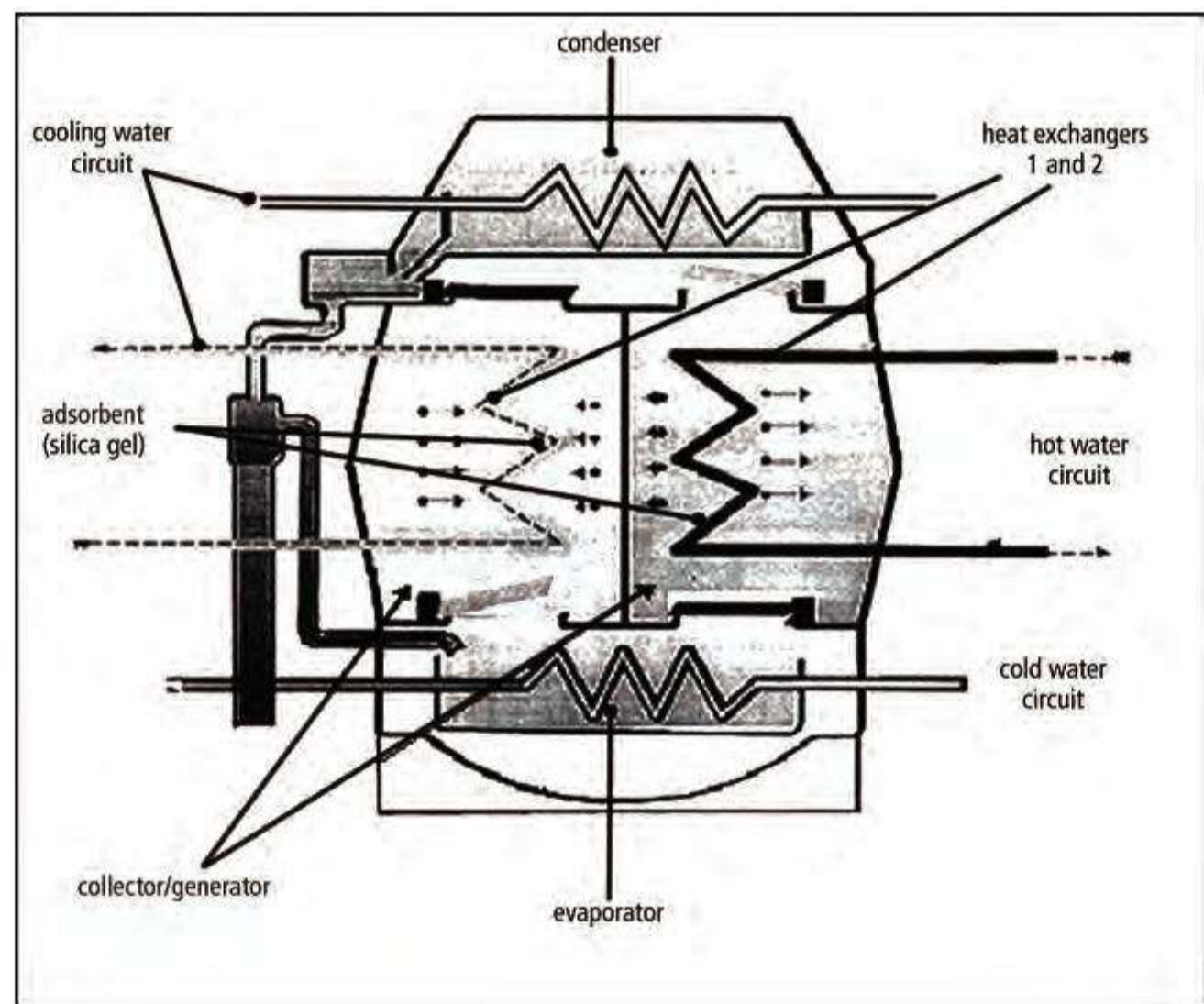

Figure 9.4.
Design for a low-temperature adsorption chiller⁴⁷

The AdCh essentially consists of a vacuum tank divided into four chambers. These are the evaporator (lower chamber), the generator and collector (middle chambers), and the condenser (top chamber). The generator and collector are each linked by flap valves, which open and close fully automatically as a result of the prevailing pressure differences in the chiller, to the condenser above them and to the evaporator below them. The AdCh uses water as the cooling medium and silica gel as the adsorbent. The physical properties of water and silica gel are used to produce refrigeration. At low pressures, water vaporizes at low temperatures and silica gel can bond large amounts of water without loss, reversibly and without increasing in volume, and release the water again when heat is applied.

The chiller is fully automatic in a working cycle of 5–7 min that essentially comprises the following four steps, which take place simultaneously. In the first step, water is injected into the evaporator, where it vaporizes. Heat is taken away from the cold water circuit. In the second step, the vaporized water is adsorbed in the collector. This process lasts until the silica gel is saturated. Then it is switched to the second adsorber chamber. In the following third step, the adsorbed water is desorbed after

the application of thermal energy. The collector becomes the generator. In the fourth and final step, the desorbed water is condensed in the condenser. The condensation heat is dissipated via a cooling water circuit (recooling system). The circuit is completed as the condensed water is fed back into the evaporator through a valve.

A central characteristic of the AdCh is that the collector and generator are alternately heated and cooled, with the chiller therefore working discontinuously. Thus, alternating periodically, one side is cooled by the flow of cooling water in order to dissipate the heat arising from the adsorption, while the generator is heated for desorption. The periodic change is controlled via pneumatic valves. The chiller is controlled by measuring the cold water exit temperature. An advantage of the AdCh process compared with the AbCh is that it is not limited by a crystallization limit of the solvent.

Adsorption chillers are a new technology, currently with only a few demonstration projects in operation, and in the first market introduction phase. In respect of the use of AdCh for solar cooling, it is of particular note that they can be used to produce cold with temperatures starting from 55°C (131°F). Hence both evacuated tube collectors and high-end flat-plate collectors are suitable as solar thermal energy converters.

9.2.4 Desiccant cooling system

In contrast to the absorption and adsorption processes, the desiccant cooling system is termed an open process, as here the air is conditioned by coming into direct contact with the cooling medium. Water is used as the cooling medium, which gives this technology excellent environmental characteristics. In addition, the sorbent – either solid or liquid – also comes into direct contact with the conditioned air. This achieves the required dehumidification of the air.

9.2.4.1 DESICCANT COOLING SYSTEM USING SOLID SORBENTS

Figure 9.5 shows a diagram of a desiccant cooling system (DCS). Compared to a conventional air-conditioning system, the additional components – the desiccant wheel, the regeneration air heater, and the humidifiers for the extracted air and the incoming air – are integrated. On the other hand, the supply air cooler is no longer needed if the necessary scope of dehumidification can be completely implemented by the sorption wheel. A chief characteristic of desiccant cooling systems is that the dehumidification and cooling stages, which in a conventional air-conditioning system take place in one step at the air cooler, are separated.

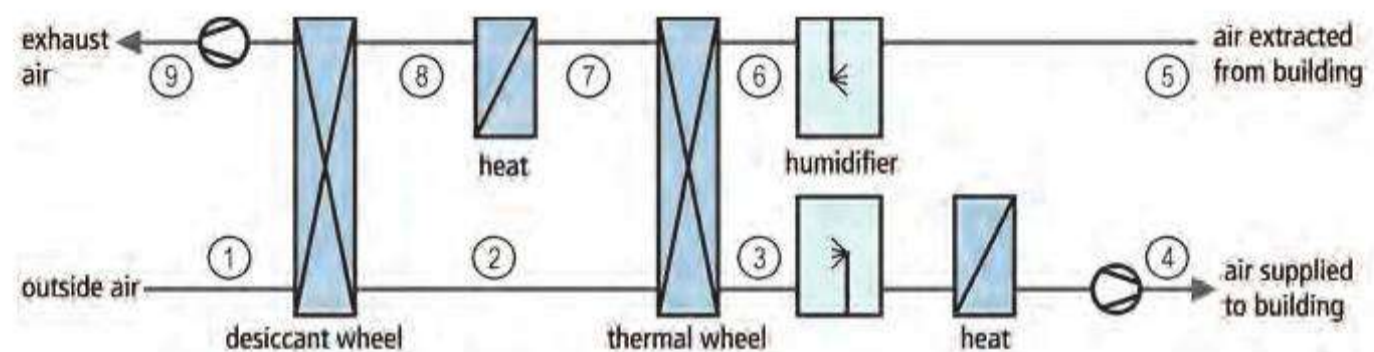

Figure 9.5.
Diagram of a DCS system with desiccant wheel⁶

Figure 9.6 shows the process (summer usage) of a desiccant cooling system in a temperature/humidity diagram. The isopleths (lines of the same relative air humidity) are shown as a set of curves.

First of all, outside air is sucked in and dried as it passes through the dehumidification wheel (1–2). The stream of air is warmed at the same time by the adsorption heat that is released. In the thermal wheel (2–3) that comes next, the heat is transferred to the exhaust air or cooling energy is recovered from the exhaust air, and hence the dried incoming air is pre-cooled. In the supply air humidifier (3–4), the air is humidified and cooled adiabatically. The additional heat exchanger before the supply air humidifier is provided only for the heating scenario. The dried, cooled air is supplied to the building and undergoes slight warming in the ventilator (usually 0.5–1 K). As a result of sensitive and latent cooling loads in the room, the room air becomes warmer and is extracted from the room as warm, moist air (4–5). The extracted air is then humidified in the exhaust air humidifier until it is close to the dew point, in order to utilize the cooling potential of the extracted air (5–6). This

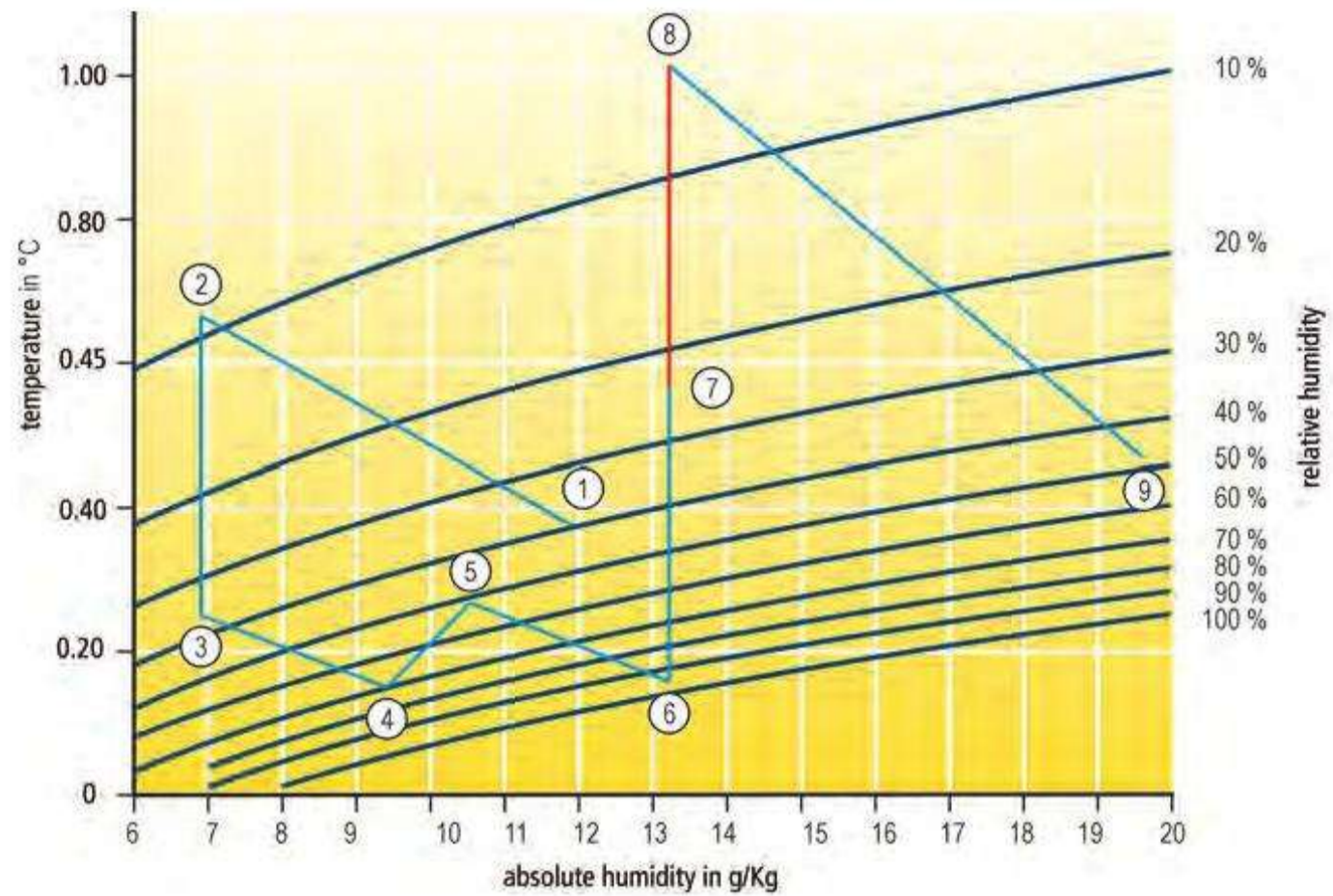

Figure 9.6. Process diagram (summer) of a DCS system with sorption rotor. Source: Fraunhofer ISE

cooling energy is then transferred to the supply air via the thermal wheel (6–7). In order to regenerate the desiccant wheel, the exhaust air has to be heated sufficiently so that it is able to strip the moisture from the wheel. An external heat source is required at this point in the process (7–8). The heated exhaust air flows through the regeneration side of the desiccant wheel as regeneration air, where it strips the moisture taken up from the outside air (8–9).

9.2.4.2 DESICCANT COOLING SYSTEM USING LIQUID SORBENTS

As well as the desiccant cooling system using solid sorbents, which has been established in the market for several years and for which there are already several hundred systems in operation in Europe, there is also a desiccant cooling system that uses liquid sorbents. This process is still under development, and the first pilot systems are currently being tested in Germany and in Israel^{48,49}. It is unlikely that a fully developed product will appear on the market before 2005.

As the name implies, the essential difference is in the physical state of the sorption material. In systems that use liquid sorbents, there is a preference for using water-based salt solutions (for example LiCl or CaCl₂). The results of various independent investigations have shown lithium chloride to have the greatest potential in respect of practicality. When selecting the optimum salt solution, as well as the purely thermodynamic properties, aspects such as corrosiveness and cost are of course also important.

Figure 9.7 shows a highly simplified diagram of the principle of a liquid sorption system. Only the two core components – the absorber and the regenerator – are shown in the figure. Looking at the basic principle, the open process of desiccant cooling using liquid sorbents has many parallels with the closed absorption refrigeration method.

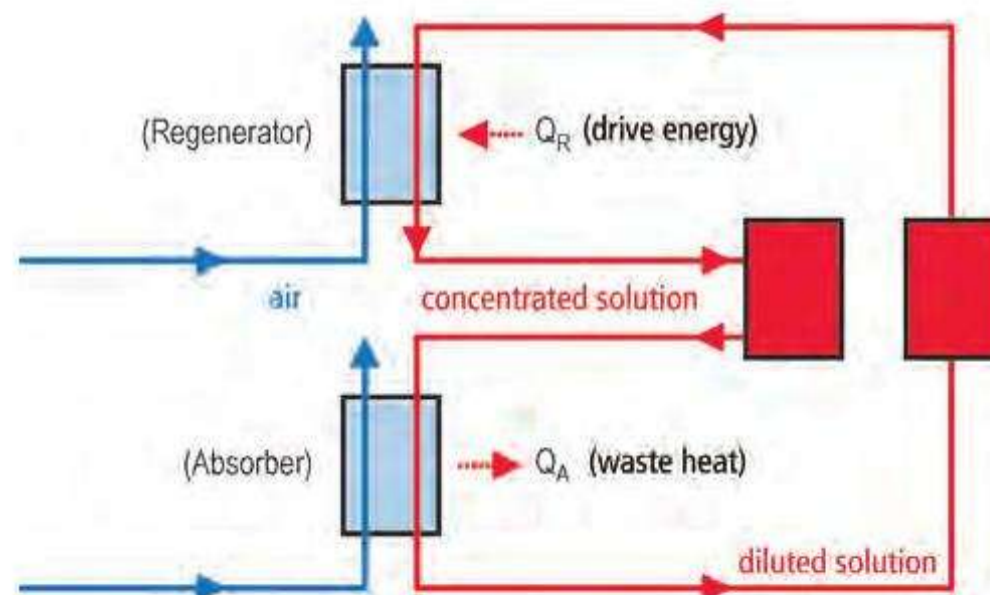

Figure 9.7. Operating principle of a DCS system with liquid sorbents

The conditioned air is dehumidified in the absorber. Here the air is brought into contact with the liquid sorbent. Because of its highly hygroscopic properties, the sorption medium absorbs the water vapour that the air contains, thus becoming diluted. In the absorber, the heat – referred to as *absorption enthalpy* – is released, and this has to be removed. If this heat were not carried off, there would be a sharp rise in the temperature of the solution, and the absorption process would gradually be disrupted. In practice, the released absorption heat can be removed either directly in the absorber or in a heat exchanger downstream of the absorber. Thus, in the *absorber*, with the removal of heat there is a *reduction in the concentration of the water-based salt solution*.

In the regenerator, the concentration of the diluted salt solution is increased. For this, the diluted salt solution is brought into contact with the air again. Outside air is generally used for this process. In the regenerator, heat must be supplied to the process. As the required driving heat needs to be available at temperatures of ‘only’ 60–80°C (140–176°F), the integration of solar thermal energy suggests itself strongly here. Thus, in the *regenerator*, with the application of heat there is an *increase in the concentration of the water-based salt solution*.

The water-based salt solution therefore travels round a circuit, in principle, but comes into contact with air in the absorber and regenerator. In order to prevent the loss of salt – but also the associated potential corrosion problems in air ducts – one of the most pressing tasks in the development of this technology is to prevent the discharge of salt in the absorber or regenerator (known as *carryover*). This has a marked influence on the design of the absorber and regenerator. Both are essentially very similar in structure. The main task consists of bringing the air and the salt solution into contact with each other, either in counter-flow or in cross-flow, in such a way as to ensure good mass and heat transfer properties and at the same time prevent droplet formation.

Apart from these development challenges, solar air-conditioning (SAC) technology using liquid sorbents does, however, have some significant advantages over SAC using solid sorbents:

- Isothermal dehumidification of outside air is possible. Because it is possible to remove released absorption heat directly in the absorber, it is therefore possible to dehumidify the air being conditioned without causing an increase in temperature. This is impossible, even in principle, with sorption wheels. As a result, significantly higher dehumidification ranges can be achieved with the same air temperatures, or, with the same dehumidification ranges, significantly lower supply air temperatures are possible.
- Heat recovery between the released absorption heat in the absorber and the required driving heat in the regenerator is possible in principle. This enables the thermodynamic efficiency of the process to be increased.
- Because the sorption material is liquid, it can be used at a later time in the absorber or regenerator if solution reservoirs are installed. This first allows dehumidification even if there is no solar energy available at the time. Second, solar energy can be stored in the form of concentrated salt solution (see Figure 9.7). This is particularly promising as *this type of solar energy storage is in principle free of losses*. Hence this technology offers the potential to significantly reduce the required collector surface while keeping the same high solar fraction and hence helping to improve the cost-effectiveness of the solar air-conditioning system.

9.3 Integrated planning of solar cooling/air-conditioning systems

In contrast to solar thermal domestic hot water supply, system planning and system design for solar air-conditioning systems is significantly more complicated. Figure 9.8 shows various subsystems, which are linked to each other in a concept for a facility’s solar air-conditioning system. The four subsystems are:

- building
- air-conditioning system
- heat supply
- cold supply.

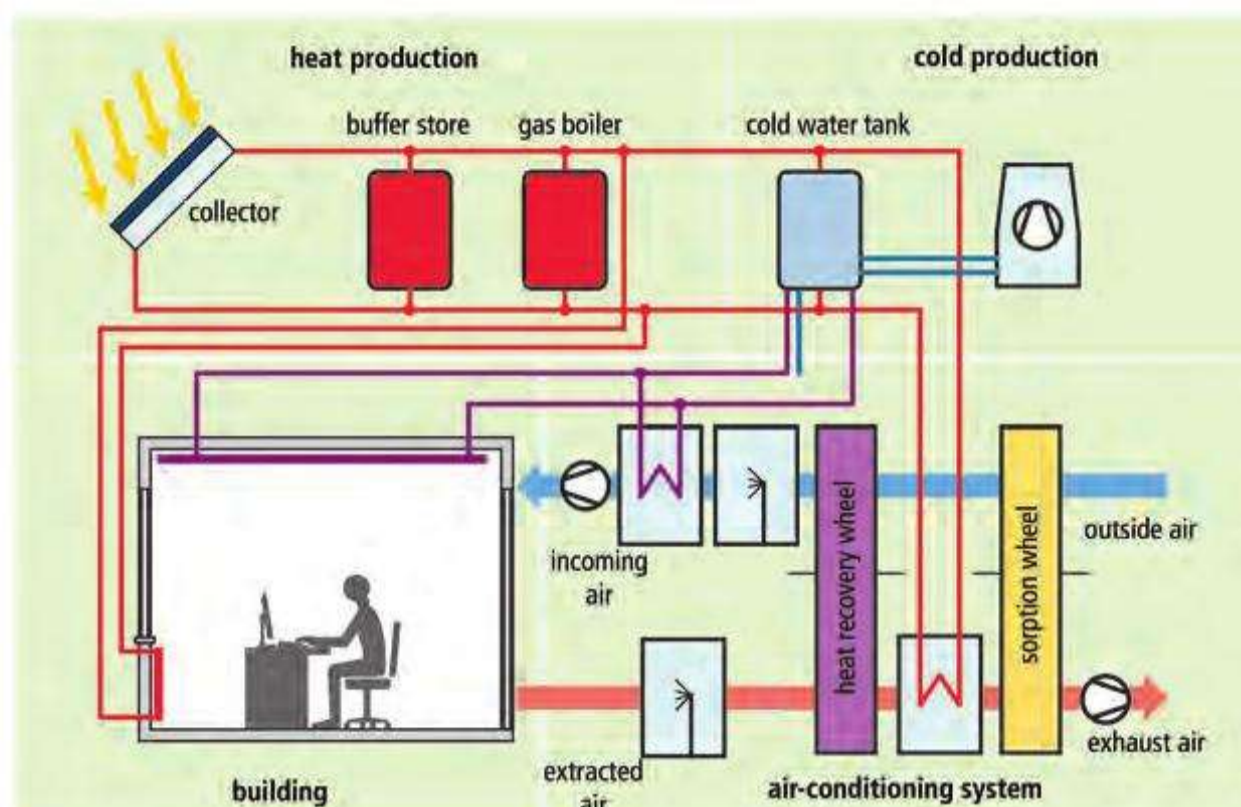

Figure 9.8.
Subsystems of solar air-conditioning.
Source: Fraunhofer ISE

Depending on the requirements of the air-conditioning task and on the climate zone, all four subsystems or only some of them will be in use. There is a distinction to be made between full air-conditioning with all four thermodynamic conditioning functions (heating, cooling, humidification and dehumidification) and partial air-conditioning (for example only heating and cooling).

The greatest challenge is to connect these systems together in an intelligent way. Hence, to achieve an overall concept optimized in terms of energy and economics, integrated planning with good communication between the various disciplines from the beginning is very important.

In air-conditioning for buildings there is no silver bullet – instead there is only the particular customized and optimized solution for each site. At the same time, climatic conditions are also very important, and there is a demand for set-up variants adapted to the climate. Designing a system using rules of thumb, as for solar thermal domestic hot water supply, entails a number of difficulties and at best only allows the basic variables to be determined.

For an economically rational solution it is always important to check first whether anything can be done to the building to reduce the cooling and heating loads. The main strategies are:

- thermal insulation of the building shell
- integration of the exterior sunshade systems
- reduction of the internal loads by using energy-saving appliances.

In addition, the possibility of night ventilation should be examined early on in the planning phase, as should the possibility of activating the thermal building mass (for example using concrete construction elements as active thermal components).

The most important steps in a good integrated planning concept are set out below. As planning should always be based around an actual project, we do not claim that this list is complete, nor that the order must necessarily be followed. This recommended method is merely intended as an aid for future planning.

- (a) Calculate the hygienically necessary rates of air change for the air-conditioned rooms. In this way, for example, it may be possible to do without mechanical ventilation completely for air-conditioning in an IT room in which people spend only short periods of time. This makes big reductions in investment costs, as in this case the air-conditioning subsystem can be completely eliminated. For rooms where only very low rates of air change are required, check whether these could be implemented via appropriate cross-flow openings from other rooms or possibly by window ventilation. In this context, check whether window ventilation, if it were possible in principle, would nevertheless result in unacceptable working conditions because of noise pollution (for example close to busy streets). Generally workplace guidelines should also be followed.

- (b) If mechanical ventilation as at (a) is deemed to be necessary, then see whether this can be implemented with a pure supply air system or with a pure air extraction system. In this case, include appropriate cross-flow openings in the façade and/or partition walls to corridors/adjacent rooms in plans. From the point of view of investment costs, these types of simplified system should be examined in every case and, if need be, should be compared with the resulting operating costs. This can lead to different system decisions, depending on the climate zone.
- (c) Check whether splitting the air-conditioning system into different zones would be a good idea. In some circumstances this can lead to large cost savings. In this context, examine in particular the possibility of bringing together locally those IT units that produce large quantities of waste heat.
- (d) Examine measures on and in the building to reduce the cooling and heating loads, and incorporate these in the planning. Generally, for buildings that have large areas of glazing, the possibility of an external sunshade system should always be investigated. This measure brings a very considerable reduction in cooling loads in the building, and it is cost-effective. Calculate the resulting cooling and heating loads for the building. It is highly recommended as well to take into account the partial load characteristics in respect of the heating and cooling load from the beginning, as the system operates with a partial load for the greater part of the year and hence this has the greatest influence on the energy consumption of the system as a whole. For more complex building structures, building simulation calculations are always a good idea.
- (e) Check what requirements exist for the building in respect of flexibility of the type of use in the expected lifetime of the air-conditioning system. This question can have a very strong influence on deciding the type of air-conditioning technology.
- (f) Check what temperature and humidity limit values will be desired and accepted in the building. Moreover, check whether it is acceptable to users and the technical process to exceed or fail to meet these temperature and humidity limit values for a particular number of hours per year. Checking this point can in some circumstances dramatically reduce the investment costs.
- (g) Select the air-conditioning technology that is right for the particular use of the building (here questions such as the presence of toxic exhaust air, for example, should be checked as well) and the climatic zone (here it is quite possible that, for large buildings, different solutions will be found for different zones).
- (h) Check whether, and which, thermally driven cooling systems come into consideration in principle. Check possible (partial) shading of the collector field.
- (i) Check whether cost-efficient waste heat is available at the required temperature level, and whether the heating energy available from the waste heat is sufficient.
- (j) Check to see which solar technology comes into consideration in principle for the appropriate cooling technology.
- (k) Produce a rough design of the solar system with annual simulation calculations. At this stage the various collector technologies and their specific system costs can and should be investigated. When estimating the solar system costs, always take the effect of scale into account.
- (l) Check whether the existing roof and/or façade surfaces are sufficient to implement a large part of the required driving heat with the solar thermal system. If it is possible and architectonically acceptable to integrate the collector system into the façade or on the façade, the collector system can serve a dual purpose – that is, for use to supply heat and as exterior shading. In this case, go back to point (d) and investigate its influence on the heating and cooling load.
- (m) Produce a first cost estimate. For this, take the following information into account:
- Prices for electrical power (kilowatt-hour and capacity price).
 - Prices for providing heat (kilowatt-hour and capacity price).
 - Prices for the relevant collector technology. (Here the influence of the collector field size must be taken into account, as this can in some cases lead to very big price reductions. Thus, by enlarging the collector system from 10 m² (107.6 ft²) to 100 m² (1076.4 ft²), in some circumstances it may be possible to reduce the specific system costs by around 30–50%.)
 - Possible subsidies for the solar technology.

- Prices for the air-conditioning technology and cooling technology being considered. (Here bear in mind that, because of the intense competition in the air-conditioning industry, there may well be considerable price differences between the cost estimate and the results of the tendering process. This should be taken into account in the planning process.)

In general, the influence of the electrical capacity charge has a considerable influence on the cost-effectiveness of a thermally driven cooling system compared with an electrically powered compression chiller. However, in this respect it is critical to check whether the capacity peaks for the electrical power consumption are actually brought about by the air-conditioning task. If this is not the case, then this potential saving cannot be included in the economic efficiency evaluation. For future economic efficiency evaluations it may also be of interest to cash in on the possible carbon dioxide saving through emission trading.

After steps (a) to (m), iteration steps may still be necessary if the basic conditions in the planning process change. At first sight the process appears to require a lot of work, but the planning effort will pay off for the customer by providing a solution that is optimized in terms of energy and economics.

9.4 System technology

This section provides an overview of the system technology for solar air-conditioning systems. It will explain the fundamentally different concepts of autonomous solar-powered systems and solar-assisted systems. It will consider which collector technologies can be best implemented for the various thermally driven cooling technologies. In addition, it will describe various switching variants for the solar connection.

9.4.1 Autonomous solar-powered systems versus solar-assisted systems

In central European climates, autonomous solar thermal systems (related to the thermal power) are not economically viable as solar heating systems, because of the seasonally very different solar irradiance conditions. For solar cooling systems, on the other hand, two concepts are possible that are different not just technically but also in economic terms (Figure 9.9):

- solar-assisted systems
- autonomous solar-powered systems.

In *solar-assisted systems*, the solar energy supplies only part of the driving heat required for the summer air-conditioning. Whenever the directly available and/or

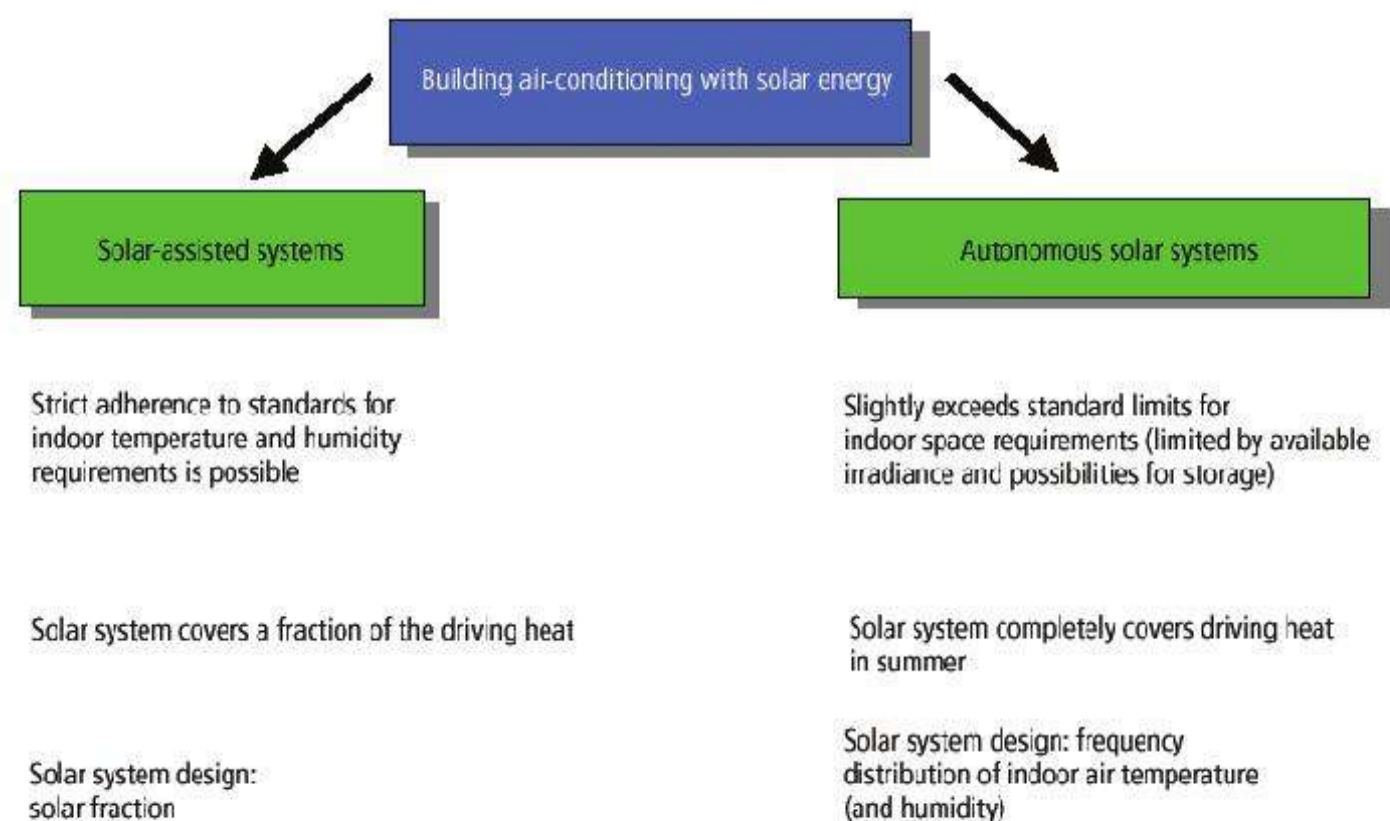

Figure 9.9.
System concepts for solar cooling systems. Source: Fraunhofer ISE

stored solar energy is insufficient, enough driving heat can be provided via the conventional auxiliary heating system. This enables the design requirements for indoor space always to be attained (if the cooling and air-conditioning systems are correctly designed). In these systems the attainable solar fraction is utilized for sizing the design. In this context, the solar fraction for cooling is used. This is always less than 100%. The solar fraction for heating can also be calculated based on the fraction of heat energy used for the heat supply and/or averaged for the heating and cooling season based on the entire energy used for the heat supply. The conventional auxiliary heating system is always necessary and is generally designed so that the complete driving heat can be provided via the auxiliary heating system. With detailed prior planning (simulation calculations of the entire plant are necessary), and depending on the building, climatic region and size of the selected heat storage tank, under certain circumstances it is possible to dispense with part of the thermal output from the conventional heating system. In this case, use of the solar system enables costs to be saved in terms of the auxiliary heating system. This can have a positive impact on the economic efficiency of the solar air-conditioning.

With *autonomous solar-powered systems*, the complete driving heat for the summer cooling and air-conditioning is provided by the solar collector field. In these systems, as much air-conditioning is achieved as possible with the available solar heat. An intelligent control strategy is very important in these systems. By their very definition, these systems dispense with an auxiliary heating system. The solar fraction for cooling is therefore always 100%. Thus it does not make any sense to design these systems using this parameter. As there is no auxiliary heating system in autonomous solar-powered systems, depending on the system design there may be hours with extreme external conditions when limit values for indoor temperatures and/or humidity are exceeded in the building. The number of these excess hours as well as the size of the deviations from the limit values can be determined through simulation calculations and utilized as design criteria. This is why, when designing autonomous solar-powered systems, it makes sense to use simulation calculations that consider the solar system *and* the building in *one* simulation. For buildings with a very large temporal correlation between the solar irradiance and the cooling load to be removed, self-contained solar systems are interesting not only technically but also economically. A typical example of such a building could be an office building used predominantly during the day with extensive glazed areas in the façades. The advantage of these systems lies in the simplified system technology. Costs can be saved by dispensing with the auxiliary heating system and the back-up heat exchangers. For autonomous solar-powered systems, integral planning is even more important, as changes in the building during the planning without a corresponding adaptation of the solar heating system can have an immediate impact on the later comfort conditions in the building.

9.4.2 Which collector technology for which cooling technology?

One of the most important questions concerning the system technology of solar air-conditioning systems is the choice of the correct solar collector technology. To answer this question it is important to compare the driving temperatures of the various thermally driven cooling technologies. These are depicted in Table 9.2. The driving temperatures for single-stage absorption chillers are between 85°C (185°F) and 110°C (230°F). For two-stage models they are even higher, at around 150°C (302°F). For adsorption technology the driving temperatures are somewhat lower at 55–90°C (131–194°F). The driving temperatures for desiccant cooling systems (DCS) are the lowest. This applies for desiccant cooling systems with both solid and liquid sorbents. With the latter, according to the current state of knowledge, the minimum driving temperatures are slightly higher (approximately 55°C; 131°F); however, there is potential for improvement here.

Table 9.2.
Overview of thermally driven
cooling technologies and driving
temperatures

Process	Absorption	Adsorption	Desiccant cooling system
Type of air-conditioning	Chilled water (e.g. chilled ceilings)	Chilled water (e.g. chilled ceilings)	Air-conditioning (cooling, dehumidification)
Driving temperature (°C)	85–110	55–90	45–90

When deciding which collector technology is best suited for a particular cooling technology, the efficiency curves play an important role for the various collectors. In Figure 9.10 the efficiency curves for the most widely used solar collectors are displayed as a function of the mean liquid temperature. If it is assumed that the collector efficiency for the respective application should amount to at least 50–60%, then this provides the following picture with regard to Table 9.2.

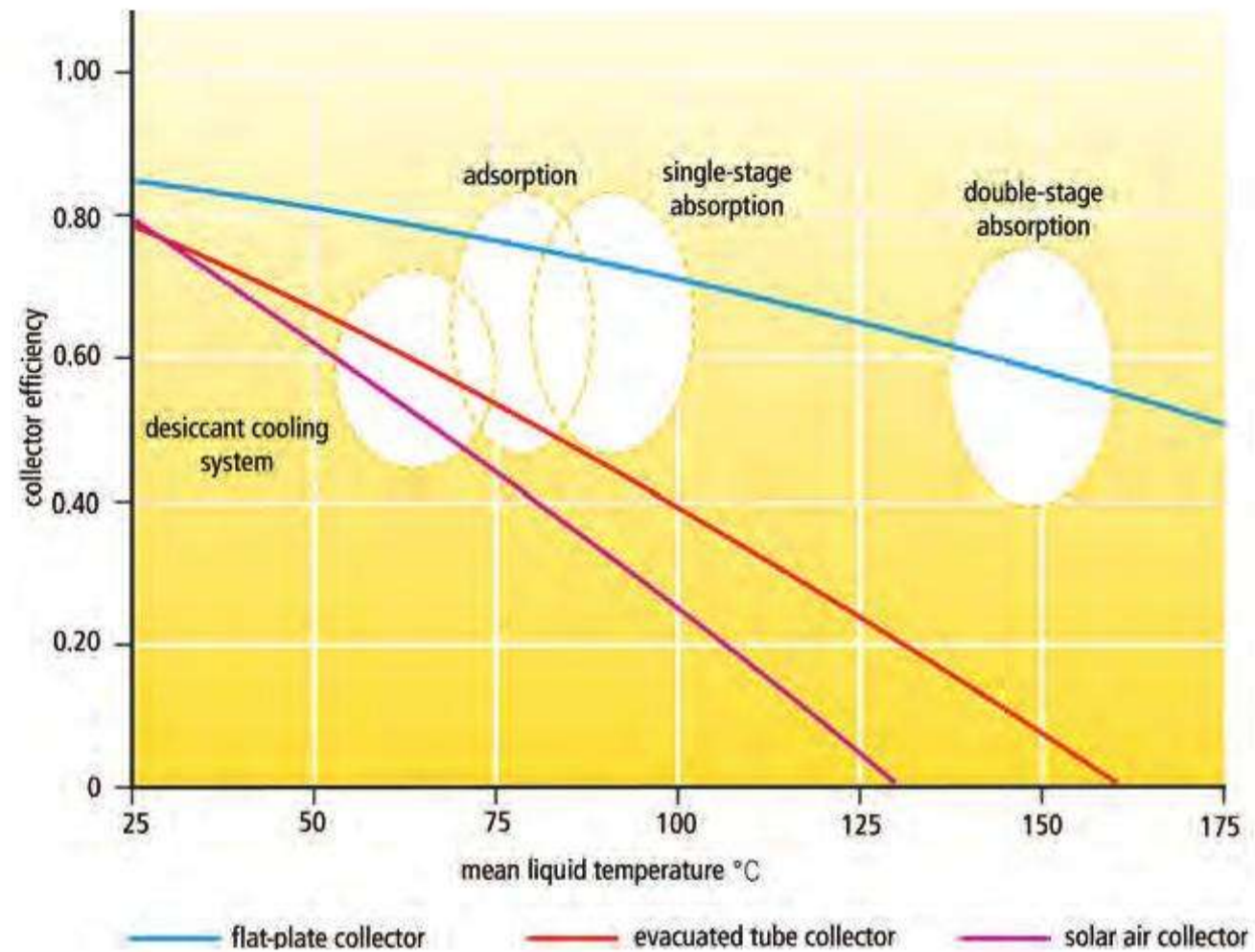

Figure 9.10. Collector efficiency for typical solar collectors. Source: Fraunhofer ISE

For desiccant cooling systems, both flat-plate collectors and solar air collectors can be considered. In principle, evacuated tube collectors are also highly suitable; however, their higher price counts against them. For adsorption chillers, very good flat-plate collectors or evacuated tube collectors can be considered. For single-stage absorption, evacuated tubes are more suitable. From the economic point of view, flat-plate collectors would probably not be considered for absorption applications, even if technically feasible. If they were used, then this would be only with very large collector areas. For two-stage absorption, only evacuated tubes come into consideration.

Apart from the efficiency curve aspect, the following factors play an important role when choosing suitable collectors:

- *Specific collector price.* Here you can compare both the price per installed square metre of collector field and the price per kW of thermal output at the desired target temperature. The latter figure enables better comparability; the resulting collector field size should also be considered, however, as this has an impact on the costs of the substructure.
- *Local shading situation.* It is important to analyse the local shading situation. This can also considerably influence the choice of the collector type if, for example, there is insufficient area for the flat collectors because the intended roof area is partly shaded.
- The possible *integration of solar collectors in the façade* can be tested in relation to the project. In this case structural aspects and, in particular, the appearance can be decisive in deciding for or against a specific collector technology. In such cases the possible substitution of façade components with the implementation of flat-plate or solar air collectors is an important factor. With many types of evacuated tube this is not possible.

9.4.3 Circuit variants

In terms of the system technology, the possibilities to connect the solar system to the entire solar cooling system are also very important.

In general we can differentiate between the following systems:

- systems with solar liquid collectors
- systems with solar air collectors
- systems with solar heat input only via the heat storage tank
- systems with direct input of the solar heat into the air-conditioning technology
- systems with auxiliary heating in the heat storage tank
- systems without auxiliary heating in the heat storage tank (only with solar heat storage tanks).

In turn, there are also hybrid versions based on these systems, and of course other systems are also feasible. The following illustrations are simply schematic diagrams to clarify the integration of the solar technology; they should not be understood as hydraulically complete circuit diagrams.

In terms of the cooling technology, all the relevant possibilities are illustrated; for investment reasons, however, it is very seldom that they are implemented at the same time. When using adsorption chillers, a cooling storage tank should definitely be integrated into the system in order to control the stability of the system. With absorption chillers, a cooling storage tank can also be advantageous. Which system is used in the end should always be decided in terms of the particular project.

Figure 9.11 shows a solar cooling system with solar liquid collectors whereby the solar heat input is only via the heat storage tank. There is also auxiliary heating in the heat storage tank. The system has the following features:

- It is suitable for absorption and adsorption chillers as well as desiccant cooling systems (solid and liquid).
- It is possible to integrate flat-plate collectors and evacuated tube collectors.
- There is dynamic decoupling of the solar system and cooling technology/air-conditioning through the heat storage tank.
- There is increased heat storage loss through auxiliary heating in the buffer storage tank.
- 'Traditional' control of the solar thermal system is generally possible.
- There is good control of the overall system through dynamic decoupling.

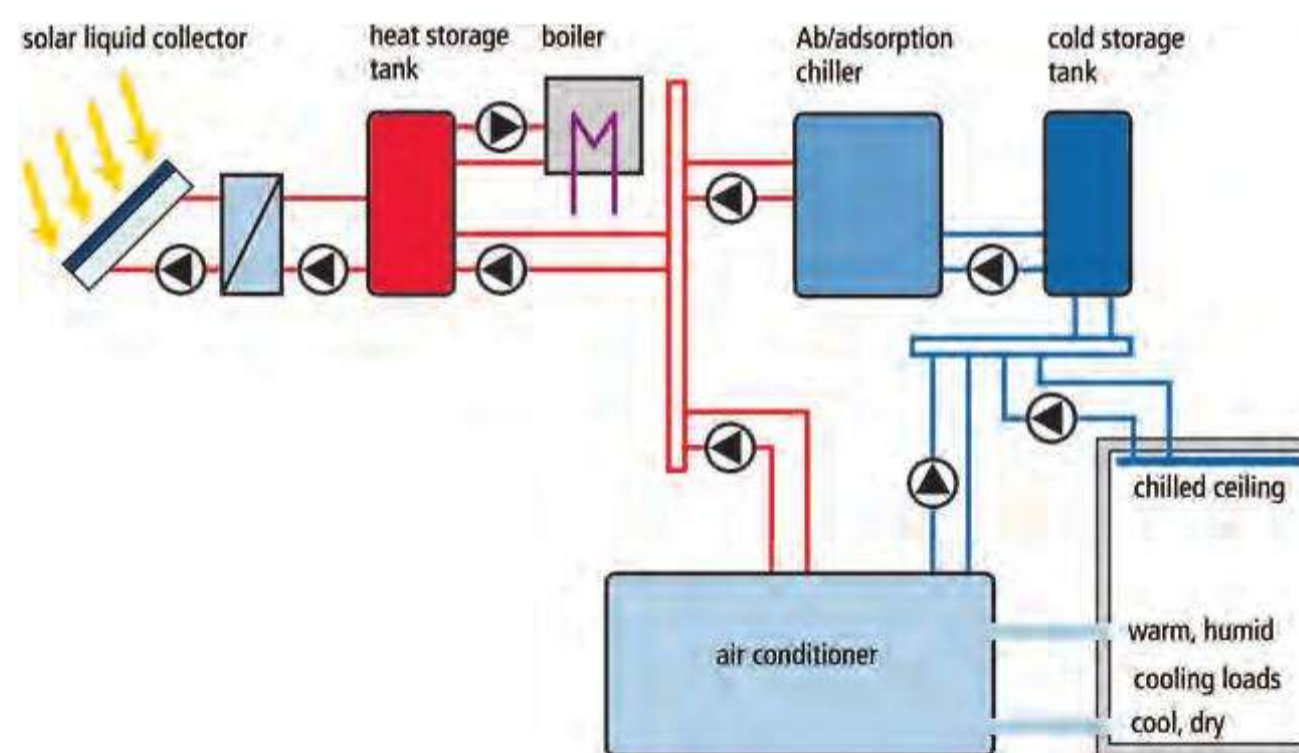

Figure 9.11.
Solar cooling system with solar liquid collectors (the solar heat input is only via the heat storage tank) and auxiliary heating in the heat storage tank

Figure 9.12 shows a solar cooling system with solar liquid collectors whereby the solar heat input is only via the heat storage tank but with no auxiliary heating in the heat storage tank. The system has the following features:

- It is suitable for absorption and adsorption chillers and desiccant cooling systems (solid and liquid).
- It is possible to integrate flat-plate collectors and evacuated tube collectors.
- There is dynamic decoupling of the solar system and cooling technology/air-conditioning through the heat storage tank.

- There is reduced heat storage loss through auxiliary heating outside the heat storage tank (it is best to connect the auxiliary heating in series).
- The storage tank contains only solar heat.
- 'Traditional' control of the solar thermal system is generally possible.
- There is good control of the overall system through dynamic decoupling.

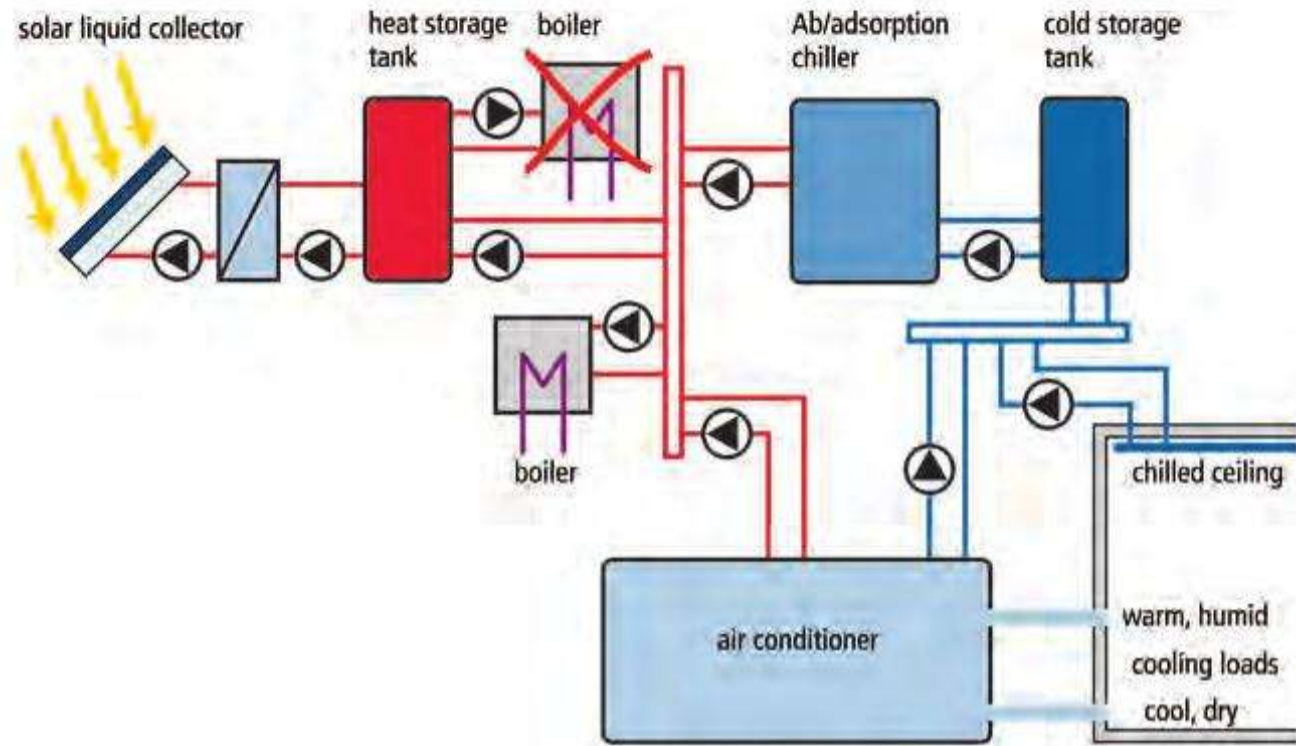

Figure 9.12.
Solar cooling system with solar liquid collectors whereby the solar heat input is only via the heat storage tank but with no auxiliary heating in the heat storage tank

Figure 9.13 shows a solar cooling system with solar liquid collectors whereby there is direct solar heat input and solar heat input via the heat storage tank, but without auxiliary heating in the heat storage tank. The system has the following features:

- It is suitable for absorption and adsorption chillers and desiccant cooling systems (solid and liquid).
- It is possible to integrate flat-plate collectors and evacuated tube collectors.
- There is dynamic decoupling of solar system and cooling technology/air-conditioning through the heat storage tank.
- There is reduced heat storage loss through auxiliary heating outside the heat storage tank (it is best to connect the auxiliary heating in series).
- The storage tank contains only solar heat.
- The collector yield is potentially higher, as the direct connection of solar heat is possible.
- The hydraulics and control are more complex owing to dynamic coupling.

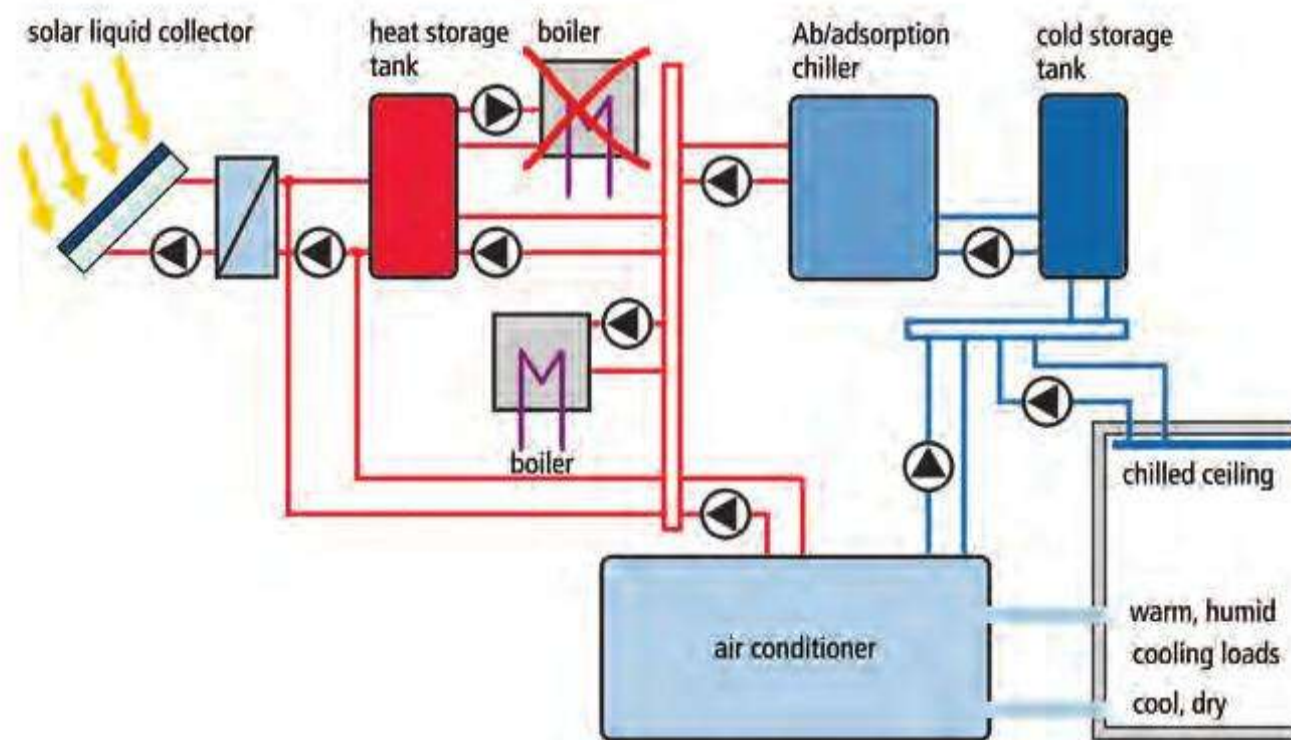

Figure 9.13.
Solar cooling system with solar liquid collectors whereby there is direct solar heat input and solar input via the heat storage tank, but without auxiliary heating in the heat storage tank

Figure 9.14 shows a solar cooling system with solar air collectors equipped with an ambient air intake. It has direct solar heat input but no heat storage tank. The system has the following features:

Figure 9.16 shows a solar cooling system with solar air collectors that have an ambient air intake. It has direct solar heat input and integration of a heat storage tank but no auxiliary heating in the storage tank. The system has the following features:

- It is only suitable for desiccant cooling systems (solid and liquid).
- It is possible to integrate solar air collectors.
- It is a solar air system with ambient air intake.
- There is direct dynamic coupling of the solar thermal system and air-conditioning system.
- It is possible to decouple excess solar heat to the buffer storage tank.
- The hydraulics and control are easier, thanks to the simplified system technology, but control must be well adapted to fluctuating irradiance.
- Low investment costs are possible.
- It also makes sense for buildings with an average temporal correlation between the irradiance and the cooling load.
- When heating, the direct solar heating of the ambient air means that diffuse irradiance is also usable in the system.

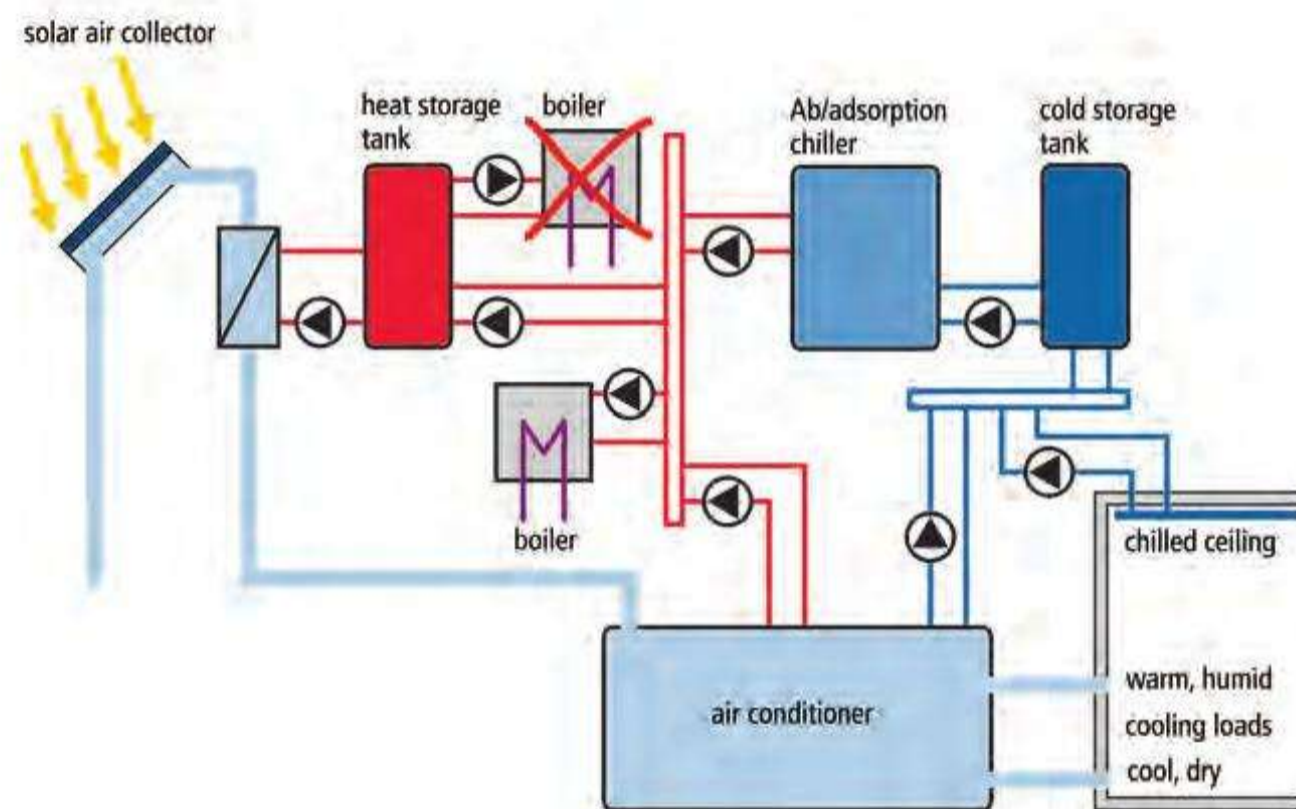

Figure 9.16.
Solar cooling system with solar air collectors that have an ambient air intake. It has direct solar heat input and an integrated heat storage tank but no auxiliary heating

9.5 System design

For air-conditioning systems, the question of the system design cannot be answered as easily as it can be, for instance, with solar domestic hot water heating. It depends substantially on two influencing factors:

- The required cooling and/or heating loads of a building or part of a building always depend on the project, and can *only* be precisely determined *in relation to the project*.

This is the largest and most significant difference from designing systems for solar water heating, where the number of persons and the resulting hot water consumption almost exclusively determine the heating load to be met by the system. Although in air-conditioning technology there are also empirical values for the specific internal cooling load (in watts per square metre) for typical uses (for example offices, seminar rooms), it is the *architecture and design of the building* and the *climatic zone* that substantially influence the resulting cooling and/or heat load to be met by the system. For example, the existence or non-existence of a good external shading device on an extensively glazed building can easily halve or double the required cooling load. The use of rules of thumb for the schematic design of solar air-conditioning systems is, as a matter of principle, more difficult, and these themselves can only be used as rough reference values. *Moreover, a substantially larger number of influencing factors must be determined first in order to determine the reference values.* It is precisely this last point that obliges the planner to plan carefully in advance.

- Until now there has been relatively little experience with operating systems.

Most installations currently in operation are part of demonstration projects. The systems were mostly conceived and planned by research institutes and then implemented in collaboration with a designer on site. Therefore there are still very few designers in planning offices who have experience of implementing several solar cooling systems. This is shown by the specific collector surfaces per kilowatt cooling capacity found in the pilot systems, which range widely from $0.8 \text{ m}^2_{\text{col}}/\text{kW}_{\text{cooling}}$ to $8 \text{ m}^2_{\text{col}}/\text{kW}_{\text{cooling}}$.⁵⁰ Although these differences are due partly to project-specific circumstances (for instance, the collector areas are not always determined by the solar cooling), it is also clear that in some cases the planners were uncertain as to the design.

9.5.1 General procedure when designing systems

Despite the complexity in individual cases, it is still possible to provide general guidance on the system design. The considerable advantages to be gained by integral planning also apply here. This particularly concerns the effect of the system design on the economic viability of the solar cooling. Here iterative steps and even compromises between energy-optimized and economically realistic system designs are often necessary.

The following steps for designing a solar cooling system should be carried out in every case:

- (1) Calculate the cooling/heating load of the building.
- (2) Optional: Calculate the cooling/heating load time series for every hour of the year based on a building simulation.
- (3) Design the air-conditioning and/or cooling technology. At this point check which air-conditioning and/or cooling technology can be utilized or is suitable for the particular building.
- (4) Optional: If step (2) has been carried out, decide whether the design of the air-conditioning and/or the cooling technology should be based on the peak load or whether a deviation during individual hours/days should be accepted. Quantify the potential effect of reducing the air-conditioning and/or cooling technology on the ventilation conditions, using a combined building and system simulation.
- (5) Calculate the driving heat capacity of the thermally driven cooling technology.
- (6) Optional: Calculate the driving heat time series for each hour of the year based on a system simulation.
- (7) Design the solar thermal system and, if intended, the heating storage tank to cover the driving heat capacity completely or partly. Design the auxiliary heating system if envisaged. In this step compare various system configurations using simulation calculations; this makes sense if (and only if) step (6) was carried out. If a façade-integrated solar system is planned or one that partly shades the façade, then at this point it can make sense to recalculate the heating/cooling load of the building according to step (1).
- (8) Calculate all the energy and water consumption in the entire system.
- (9) Calculate the costs of the solar system and the auxiliary heating system according to step (7). Take into consideration both the consumer price and the price per unit for the electricity and heat.
- (10) Calculate the costs of the entire system.
- (11) If the costs are not acceptable, iterative steps are recommended from step (3) or from step (7).

As well as the technical and economic design, both the realizable and the primary energy savings are also of interest when designing the system. This applies particularly for systems for solar cooling. This aspect will be considered in detail in subsection 9.5.5.

For a successful system design, it is always sensible to work with partners who already have practical experience in this area. The best results can be achieved through the use of simulation software that can depict both the building and the system technology, including the solar thermal system.

9.5.2 System design using empirical values

Based on experience from previously implemented pilot systems, the following provides a rough estimate in sizing the solar collector field in advance:

- For desiccant cooling systems with solid sorbents: approximately 5–10 m² (53.8–107.6 ft²) collector area per 1000m³/h (35,315 ft³/h).
- For ad/absorption chillers: approximately 1–3 m² (10.8–32.3 ft²) per kW cooling capacity.

The use of these values should mean that any excessive over- or under-dimensioning can be avoided. These reference values enable the general cost of the solar system to be estimated in the early stages of the project during the rough planning. Deviations from these reference values are nevertheless possible when there are special project conditions.

For adsorption and, in particular, absorption chillers that use flat-plate collectors the specific areas can lie above this in individual cases. The information for the desiccant cooling systems applies for both solar air collectors and liquid collectors. For desiccant cooling systems with liquid sorbents, it is expected that smaller specific collector areas will be possible, owing to the possibility of having loss-free storage. This still has to be confirmed by pilot systems monitored with measurement equipment.

It should be emphasized, however, that the reference values should not replace a detailed system design.

9.5.3 System design according to the peak load

Another design method consists of designing the solar system in a way that the nominal cooling load of the cooling and air-conditioning system, P_{cooling} , with maximum solar irradiance on the collector field (1000 W/m²) can only be provided by the driving heat of the solar system. The collector area, A_{col} , is calculated for this according to the following formula:

$$A_{\text{col}} = \frac{P_{\text{cooling}}}{COP_{\text{cooling,nom}} \eta_{\text{col,nom}}} \cdot 1$$

where P_{cooling} is the nominal cooling capacity of the cooling/air-conditioning system (kW), $COP_{\text{cooling,nom}}$ is the nominal COP (coefficient of performance) of the cooling/air-conditioning system, and $\eta_{\text{col,nom}}$ is the nominal efficiency of the solar collector at the necessary temperature for driving the cooling/air-conditioning system. In the case of heat transfer in heat exchangers, the temperature differences should be taken into consideration, too. This leads to increased temperatures in the solar collectors compared with the temperatures given as driving temperatures in the technical specifications of the cooling/air-conditioning systems. Table 9.3 shows the respective specific collector areas per kW of cooling capacity derived from the above equation.

Thus for a single-stage absorption chiller with a typical nominal COP of 0.7 and for an evacuated tube collector with a nominal efficiency of 71% (typical for mean collector temperatures of 100°C (212°F)), the resulting specific collector area is 2.01 m²_{col}/kW_{cooling}.

As can be seen in Table 9.3, the specific collector areas for adsorption and absorption chillers calculated according to the peak load method are also within the area covered by the reference values. Since with the desiccant cooling systems the rated cooling capacity of the air-conditioning system depends directly on the external conditions, the specific collector areas here are given with respect to a nominal flow rate of 1000 m³/h (35,315 ft³/h). It can be seen in Table 9.3 that the values calculated according to the peak load method lie clearly above the empirical values of 5–10 m²_{col} for a nominal flow rate of 1000 m³/h. Thus use of the peak load method with desiccant cooling systems will generally lead to over-dimensioned systems. Therefore for desiccant cooling systems it would appear sensible to reduce sizes calculated according to the peak load method by at least 30%.

The advantage of integrating solar air collectors is that no temperature differences occur at the heat exchangers. As the efficiency of 63% relates to the mean collector

Table 9.3
Collector areas per kW cooling
capacity (see text for explanation)

Cooling	COP	Collector	Temp- erature of conden- sor (°C)	Average temp- erature of collectors (°C)	Irradiance (kW)	η_{col}	$m^2_{col}/$ $kW_{cooling}$	$kW_{cooling}/$ $1000m^3$	$m^2_{col}/$ $1000m^3$
AbsCh	0.7	ETC	90	100	1.0	0.71	2.01	–	–
AbsCh	0.7	FPC	90	100	1.0	0.52	2.75	–	–
AdsCh	0.6	ETC	80	90	1.0	0.73	2.28	–	–
AdsCh	0.6	FPC	80	90	1.0	0.57	2.92	–	–
DCS: solid	0.8	FPC	70	85	1.0	0.59	2.12	6.00 ^a	12.71
DCS: solid	0.8	SAC	70	60	1.0	0.63	1.98	6.00 ^a	11.90

^aThis value depends substantially on the ambient climatic conditions.

temperature, and because there are temperature differences of approximately 35 K in solar air collectors, the necessary collector output temperature of 75°C (167°F) is achieved with a mean collector temperature of approximately 60°C (140°F). This approach already takes into consideration the temperature losses of approximately 5 K that occur between the collector output and the air-conditioning system.

As when designing according to empirical values, designing according to peak load methods only leads to points of departure – even if these values are more precise. Moreover, a precise analysis of the frequency with which the peak cooling load occurs is highly recommended to avoid over-dimensioning the system. This analysis can also contribute to the determination of a sensible storage size. It should also be considered, however, that the maximum irradiance of 1000 W/m²_{col} occurs only for a very short period each day. This particularly applies with moderate climates such as those found in central Europe. Building simulations with subsequent or coupled system simulations, in which design values according to the peak load method are used as starting values, generally lead to substantially more precise results and are therefore highly recommended.

If a solar air-conditioning system is to be used both in summer *and* in winter, a design produced according to the peak load should only ever relate to the summer peak *cooling* load and the simultaneously occurring maximum *summer* irradiance; otherwise the system will be too large and will also be definitely uneconomic.

9.5.4 Design of autonomous solar-powered systems

The detailed design of autonomous solar systems always requires a combined building and system simulation. The peak load method is well suited for providing an initial guidance value for the size of the collector field.

As has already been described in section 9.4.1, the quality of the design of autonomous solar systems can be assessed by the number of hours for which the limit values for the indoor temperature and humidity are exceeded. In a combined building and system simulation, the entire system is calculated and the dynamic building response is determined for the changes in the cooling/air-conditioning system's cooling capacity as the irradiance fluctuates. In this process, possible changes to the architectural design can be examined at the same time. This is a clear benefit of this procedure.

Based on the starting values, system variations can be made in terms of the collector and, if necessary, the heat storage tank. The results relating to the excess hours provide information on the possible acceptance by subsequent users of the building. Here it is particularly important that a possible later change in use of the building is already taken into consideration in advance.

Because of the generally good temporal conformance between the irradiance and the cooling load to be removed, autonomous solar systems – particularly with buildings used mainly during the day – can provide good solutions not just in terms of the comfort criteria indoors but also in terms of the energy performance and economic aspects.⁵¹

9.5.5 System design according to primary energy saving

The main motivation for deploying solar air-conditioning systems is to save energy. This in turn means a lowering of the running costs for the operator. Therefore solar

cooling systems will only have a chance in the industrial sector in the long term if the *energy saving* and *cost reduction* aspects can be reconciled with one other.

In addition to the cost reduction aspect, it is also critical to examine whether primary energy can also be saved with the solar thermal cooling system. The concept of *primary energy* will therefore be briefly explained here. Primary energy actually means the energy content of the original energy source before it is converted. It can be divided into *non-renewable energy sources* – frequently described as conventional sources (coal, oil, gas, uranium) – and *renewable energy sources* (sun, wind, water). The concept of primary energy consumption is, however, frequently used only for energy consumption from *non-renewable* energy sources. Thus, when primary energy saving is referred to in the context of using solar technology, it is assumed that the converted solar energy is *not* a primary energy use: that is, primary energy is *saved* when gas consumption is replaced by solar energy use. This is not strictly speaking correct, but it is the normal usage, and will be so used in the remaining text.

In order to compare the various energy sources such as gas, oil and electricity with one another, they can be converted into primary energy units. For instance, in Europe 3 kWh of primary energy are used on average to produce 1 kWh of electricity. As primary energy consumption (with the exception of uranium) is directly associated with the emission of carbon dioxide, the assessment of energy systems in terms of primary energy is of considerable importance as far as the impact on global climate change is concerned.

It can be assumed at this point that a good, thermally driven cooling system uses less electricity than a compression-based cooling system. If this is *not* the case, then it should not be deployed. For this reason, in order to verify this question of electricity use, all users (including the small parasite users such as pumps or auxiliary motors) should be recorded and assessed during the planning phase.

The decisive question, however, is: Does a good, thermally driven cooling system need less primary energy than a good reference system with an electrically powered compression chiller? This is an important question for designing a sustainable solar cooling system.

Because of the clearly higher COP of an electrical compression chiller (typically 3) relative to a thermal chiller (typically 0.7 for a single-stage absorption chiller), a thermal chiller supplied purely with gas uses more primary energy! Therefore from the ecological point of view it is very important to supply a thermal chiller at least partly with 'neutral' energy forms such as waste heat or solar energy. This relation is clarified in Figure 9.17.

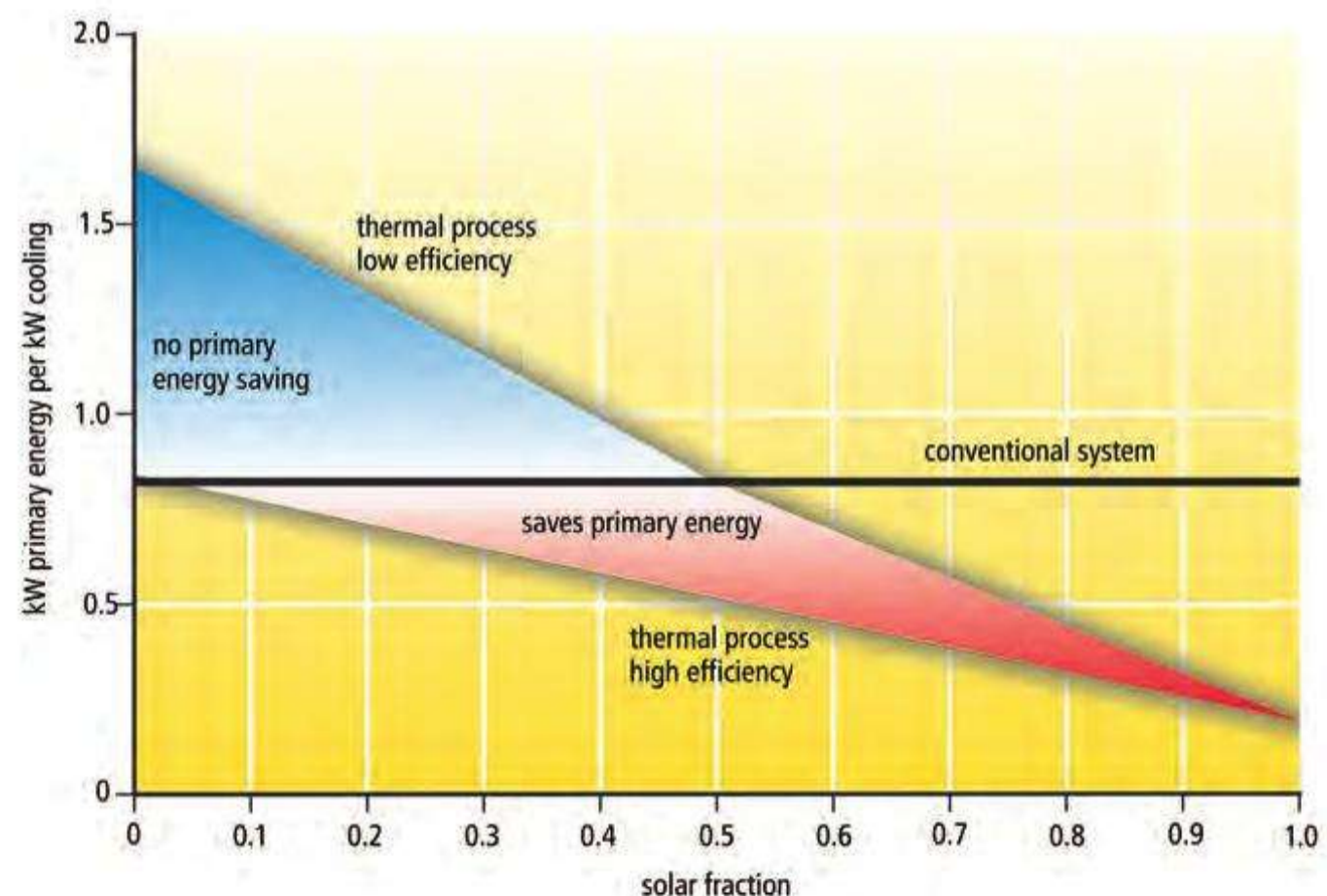

Figure 9.17.
Primary energy saving as a function of
the solar fraction. Source: Fraunhofer ISE

The higher the solar fraction used for cooling relative to the overall primary energy use, the more primary energy is saved. The minimum amount that has to be replaced by waste heat or solar energy to be equal to the primary energy is smaller or larger

depending on the efficiency of the thermal process. Therefore, in order to be able to save significant primary energy with a solar cooling system, the solar fraction relative to the driving energy when cooling should always be considerably greater than 50%. It is therefore recommended to design solar cooling systems for a solar fraction of at least 70–80%.

EXAMPLE: A SOLAR ABSORPTION SYSTEM IN SOUTHERN FRANCE FOR COOLING OF A WINE CELLAR

The solar cooling system was started up in August 1991 and has been working as planned ever since. The installation (Figure 9.18) consists of:

- 130 m² (1399.3 ft²) (solar aperture area) of Cortec vacuum tube solar collectors manufactured by Giordano. They were installed on the roof, oriented south-south-west with a 15° tilt angle.
- Technical premises on the second basement level containing:
 - flat plate stainless steel heat exchanger VICARB with a heat exchange area of 17 m² (183 ft²)
 - 1000 l (264 gallons) buffer tank
 - liquid absorption cooling machine Yazaki type WFC 15, with a nominal cooling output of 52 kW
 - the pumps needed for the different circuits
 - an electricity meter and control box.



Figure 9.18.
Solar absorption system for cooling of
wine cellar in France

- An open circuit cooling tower with an output of 180 kW, installed on the northern façade.
- Three central air-conditioning units (one on each floor) equipped with filters, a chilled water storage tank (plus a hot water storage tank for the ground floor), and a 25,000 m³/h (882,867 ft³/h) centrifugal ventilator.

9.6 More information

The International Energy Agency Solar Heating and Cooling Programme has a special task on development of solar cooling technology. More information and examples can be found at <http://www.iea-shc-task25.org/>

10 Electronic media and software within the area of solar thermal energy

10.1 Simulation programs for solar thermal systems

10.1.1 Utilization and possibilities of simulation programs

There are multiple applications within solar thermal energy for simulation programs. During planning, for example, simulation programs are used for dimensioning solar thermal systems and optimizing their yield. With the help of interpretation and simulation programs, it is possible to compare different results using different equipment variants, and to estimate operating conditions (such as collector or water storage temperatures) in detail. The use of simulation programs is also needed for accurate yield prognoses and assessments. Traditionally, simulation programs are applied both in the area of research and development as well as the area of development and optimization processes, both conducted by component manufacturers. Thus, mistakes can be avoided, and costly tests, both in terms of time and money, can be reduced. Apart from these applications, simulation programs are further used in the field of education, advanced education and continuing education.

Cost and time savings during planning and sizing have made simulation programs a popular software tool in planning offices. In addition, companies specializing in installations are increasingly using planning programs for planning purposes and for presentations to customers. Some programs are particularly suitable for this purpose, because of their appealing graphical user interfaces. Yield investigations, calculations of production costs and the specification of emission savings draw attention to the advantages of solar systems and reinforce sales arguments.



Figure 10.1.
Simulating does not replace planning,
Cartoon by Michael Hüter

Potential investors or operators of solar systems are frequently faced with questions regarding optimal system solutions, expected solar yield and the amount of energy savings. In order to answer these questions, simulation programs are mandatory. System planning should optimize the system while integrating energetic, economic and ecological criteria of different systems and system components. In the past, application

of previous experience in order to optimize the system was limited; however, nowadays this is facilitated or even made possible by retail simulation programs. Nevertheless, simulations neither replace good planning and yield estimations, nor do they always deliver reliable data, which are necessary for planning. In order to obtain realistic results, especially for larger or more complex systems, the additional engineering knowledge of a planner is essential. A plausibility check (see the line 'Input and operation' in Table 10.1) should be available in a good simulation program.

Checking is necessary in order to avoid dimensioning errors. In any case, it is recommended that planners critically evaluate the simulation results.

Some programs summarize the system design, the system data and the results in a printable report.

Several simulation programs are suitable for control calculations within existing systems, provided that they allow the import of, for example, measured radiation and consumption data. Suitability of programs for specific applications is evaluated in the program descriptions in this chapter.

If a planner regards solar thermal systems as integral components of an intelligent power supply for buildings, he/she will also inevitably need to include other programs such as energy counselling programs. Helpful examples of such programs are considered in this chapter.

Within the area of research and development, many different kinds of simulation programs have become indispensable. More and more manufacturers of solar plant components offer simulation programs that are adapted to their products.

10.1.2 Market overview, organization and selection of simulation programs

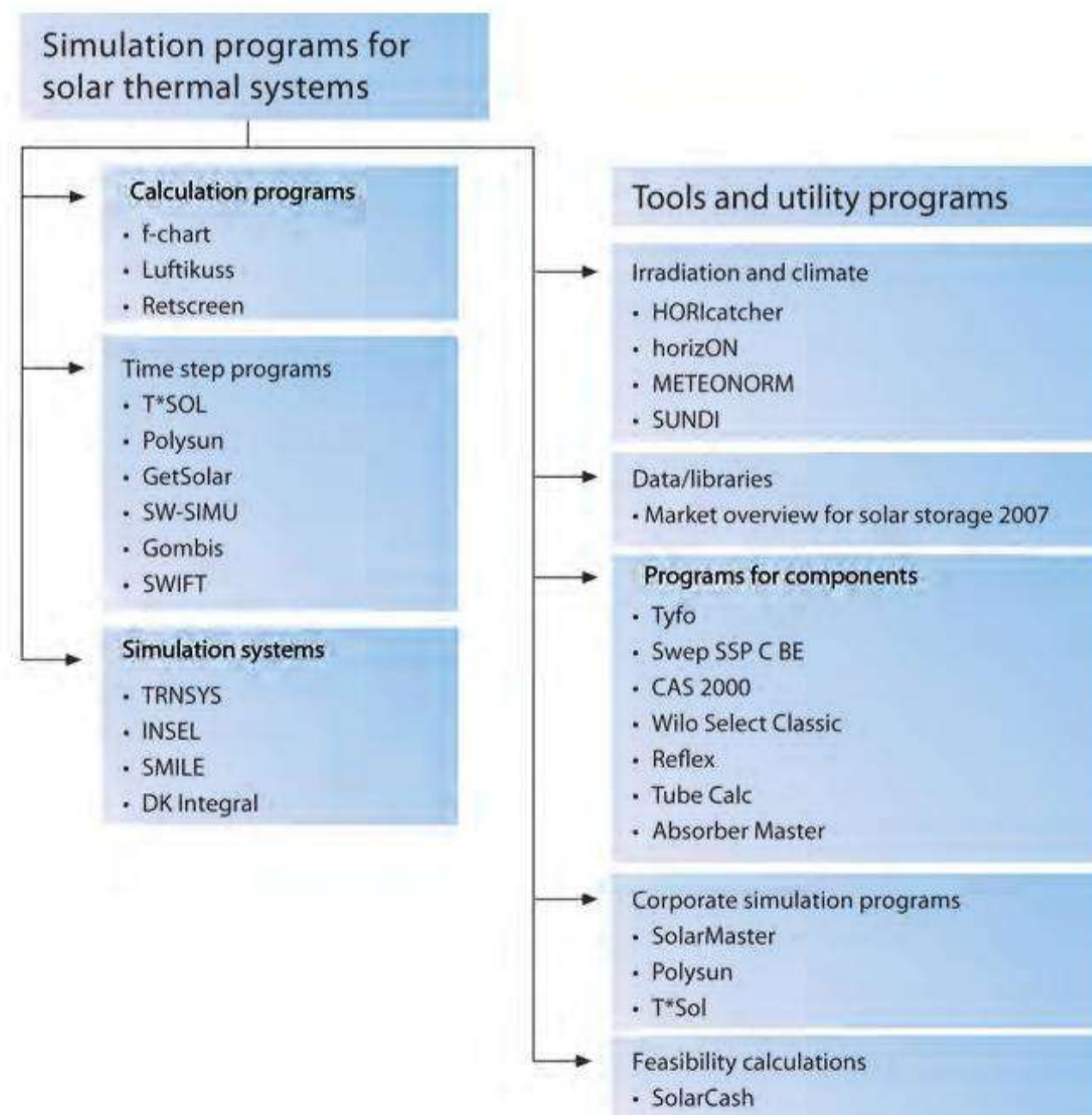

Figure 10.2.
Market survey and classification of simulation programs for solar thermal systems as well as auxiliary programs

There exist multiple applications for solar energy; therefore, there also exist multiple corresponding simulation programs. Irrespective of whether it is used for domestic water heating, support of space heating, swimming pool heating or solar air systems, any solar thermal system can be simulated on a computer. However, most programs are concerned with solar domestic water heating and space heating support. To

summarize the market, simulation programs can be classified according to their programming process into:

- calculation programs,
- time step programs,
- simulation systems and
- tools or auxiliary programs.

The system approach used in the program determines its accuracy, operating effort, flexibility, scope of application and calculating time. The price of a program is also an important consideration. However, the degree of flexibility within the use of a program is matched by the demand it places on the user.

The final category contains programs with sensible additions, or with specifications of detailed problems, or programs built for the design of the individual components of solar systems. Table 10.1 and 10.2 give an overview and comparison of the various programs.

10.1.3 Brief description of simulation programs

10.1.3.1 CALCULATION PROGRAMS

Calculation programs are simple programs based on static calculation processes. Usually only average monthly values are included for the individual locations (contrary to hourly values in programs within the other two categories). On the basis of alignment, collector type, size of collector surface area and amount of hot water consumption, they determine the yield for the whole system. The behaviour of the system under specific conditions and at shorter time intervals cannot be considered. Also, the various system configurations available on the market can only be reproduced in a very restricted way.

F-CHART

F-Charts offer a simple-to-operate user interface for dimensioning solar thermal systems with solar storage tanks for domestic water heating. The most recent version of the program is version 7.03 (9 March 2000). F-Chart will probably not be further developed.

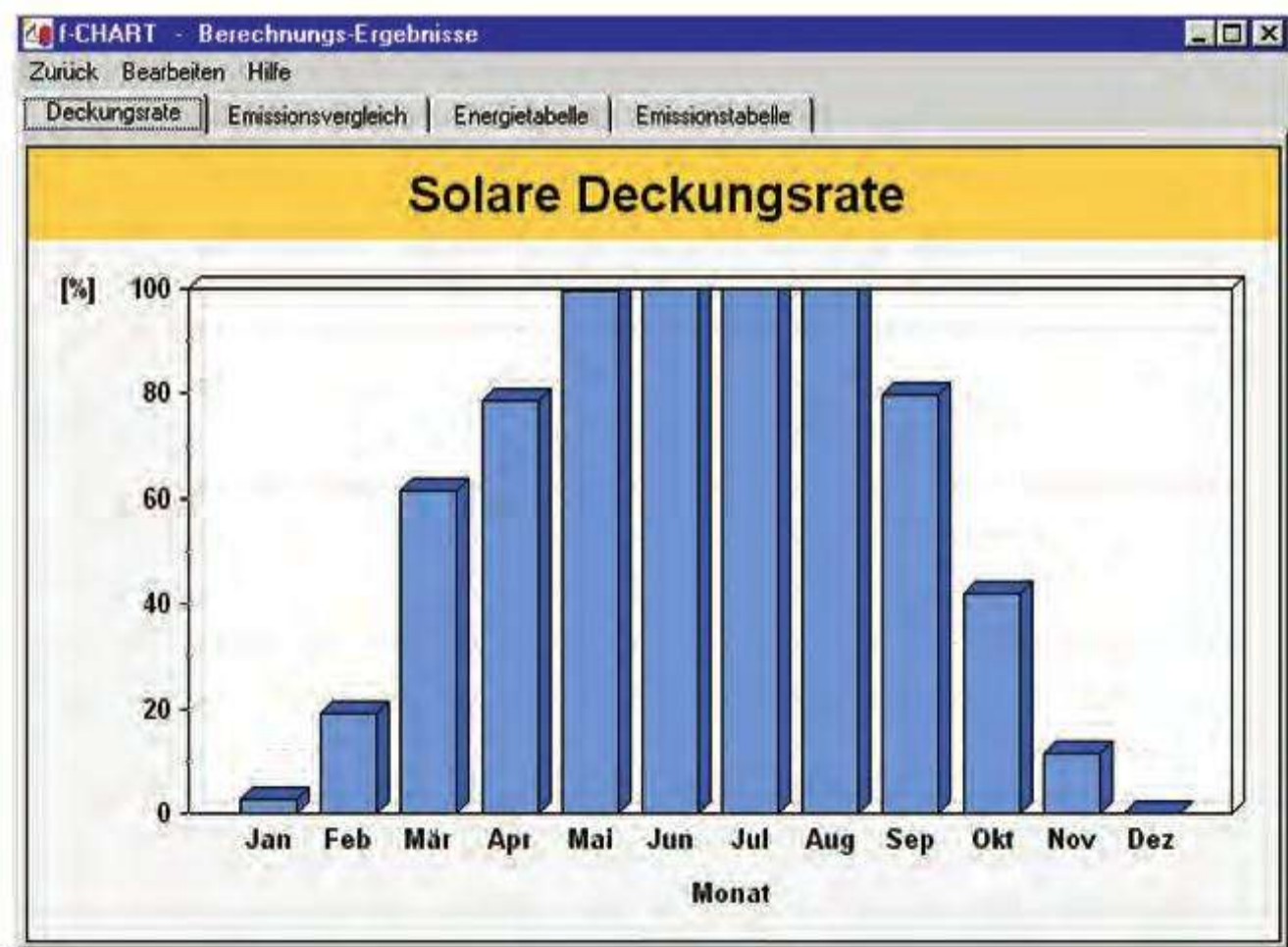

Figure 10.3.
Output diagram of an F-Chart

The entries are made on-screen; the screen is set out in such a way as to encourage meaningful entry values for the start of the simulation. The help function also includes advice on the limits and size of the parameters to be entered. About 100 European weather data records are integrated into the program (monthly averages) together with 141 collector data records. The present list of collectors was last updated in July 2002.

The accuracy of the F-Chart process – with respect to the results of annual simulation – is sufficient even in comparison with time step programs. The degree of solar coverage and the energy and emission savings are output as monthly averages over the year, in the form of graphics and tables in a three-page report.

LUFTIKUSS

This Windows program enables a quick dimensioning of air collector systems. The building is modelled by applying a one-zone model. Besides other functions, it is also possible to choose the operating mode of the collector (with fresh, mixed and circulating air), the specific collector throughput, the change of air rate, the running time of the ventilation system and the desired room temperature. It also allows for solar domestic water heating as well as heat recovery. The program output delivers the solar yield, the covering rate (or, if the covering rate is given, the surface area of the collector), the yearly energy demand of the building for heating and ventilation purposes, as well as energy and CO₂ savings. Version 2.1 can also run simulations using collectors other than those produced by the company Grammer; however, their specific values must be entered manually.

The program has improved its user-friendliness. In the case of extremely complex tasks, the TRNSYS simulation system can be used in tandem with the module TRNSAIR.

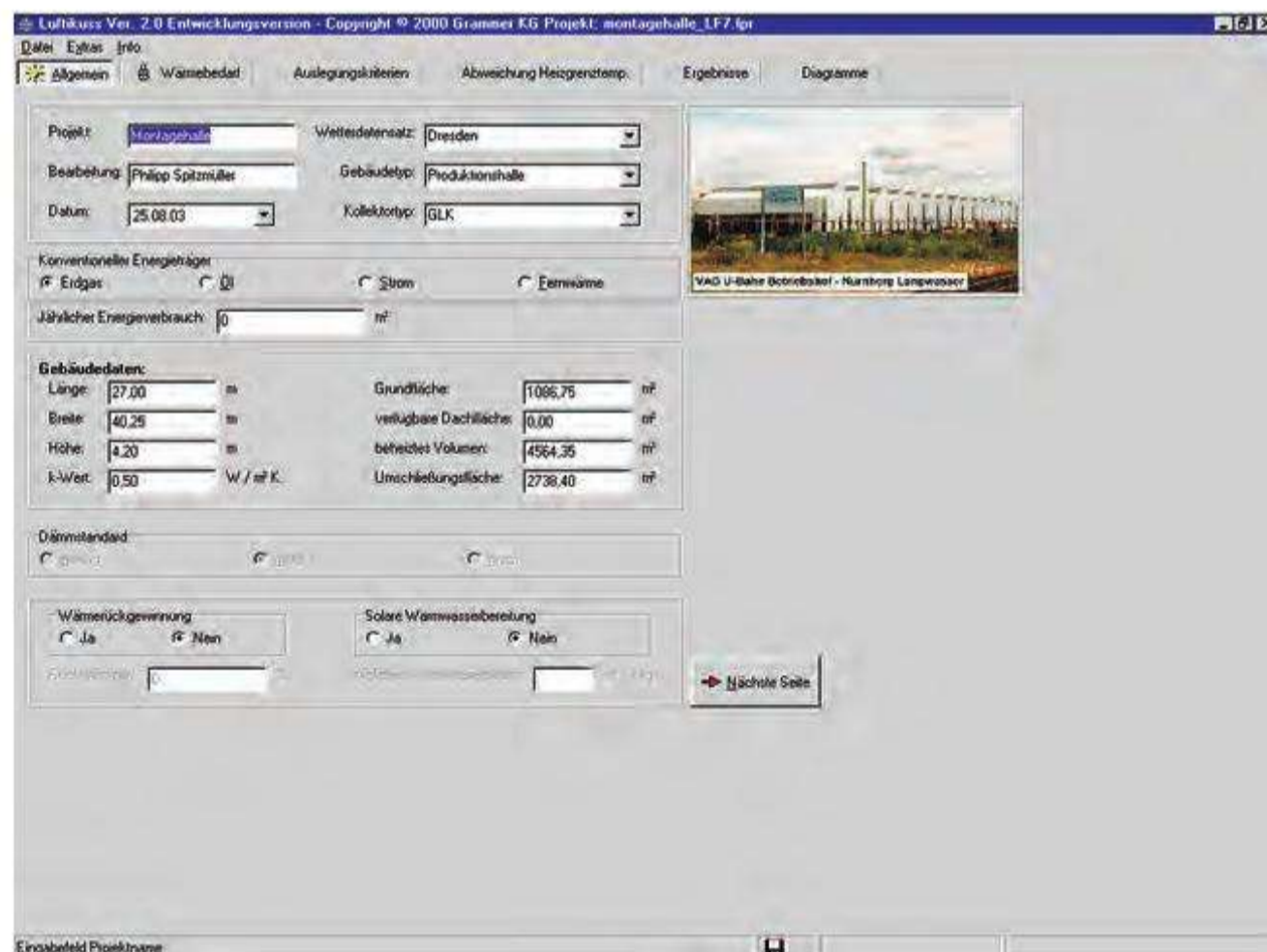

Figure 10.4.
Input screen for building values of
Luftikuss

RETSscreen

Commissioned by the Canadian government, RETScreen was developed with the help of numerous international experts from industry and universities. It is a standardized renewable energy project analysis program that uses MS Excel spreadsheets. It is available free of charge and can be used worldwide in order to assess energy production and savings, life cycle, emission reductions, financial and other risks of various energy efficiency and renewable energy technologies. The software contains product, cost and climate databases as well as a detailed online user guide. Other tools include: a middle school and high school level training course based on different case studies, an electronic technical textbook, as well as the internet website

www.retscreen.net. All of these applications are available free of charge either in English, in French or in several other languages.

Software and data requirements: Microsoft® Excel 2000 or higher; Windows 2000 or higher; Microsoft® .NET Framework 2.0 or higher. For the French Version of Windows XP or Excel XP, the latest updates from Microsoft (www.microsoft.com) are probably needed in order to use the new edition of REScreen Version 4.

RETScreen international's decision support centre for clean energy is actively working on extending the knowledge of planners, decision makers and industry, which serves as a basis for the realization of renewable energy and energy efficiency projects. This will be achieved through the development of decision support tools (e.g. RETScreen software), which reduce the costs of pre-feasibility studies; through the acceleration of the dissemination of knowledge among specialists, and through contribution to better analysis of technical and financial feasibility by running training courses.

Apart from the basic features which include renewable energy, cogeneration systems and long-distance heating, version 4 of the RETScreen software has extended its functions to incorporate the areas of profitable clean energies, heating and cooling technologies, and energy efficiency measures.

The worldwide application of the program was made possible by extending the climate database to cover areas across the globe, including the identification of areas with central or island electricity grids and areas with no grid at all. The translation of the software into 30 languages has also played a major role, as it is now accessible to two-thirds of the world's population.

The most significant results include:

- Developing a range of new models for the evaluation of energy saving measures in residential buildings, efficient use of space, institutions, communities, as well as industrial appliances and procedures.
- Extending the RETScreen climate database to 4700 worldwide tracking stations and integrating NASA data records on surface meteorology and solar energy for populated regions directly into the RETScreen software.
- Integrating existing RETScreen models for renewable energies (e.g. wind power) and cogeneration systems with new models for energy efficiency measures into one single file, and upgrading functions within existing models to evaluate innovative technologies, such as ocean current and wave power.
- Translating the integrated single-file software and databases into 30 languages (i.e. Chinese, French, German, Hindi, Italian, Japanese, Portuguese, Russian, Spanish, etc.).
- Distributing the tool via RETScreen's web page and CD-ROM, with local target groups for training and self-improvement, and by means of an international network of RETScreen trainers and development partners.

10.1.3.2 TIMESERIES DATA ANALYSIS PROGRAMS

Whereas calculation programs only carry out static simulations using monthly values, timeseries simulation programs permit a more dynamic evaluation within a particular time cycle. Simulation is made on the basis of weather data and consumption values, on an hourly or shorter resolution. Some programs permit instantaneous displays as well as for example the determination of storage temperature at a given time. The user selects the appropriate system type from preset types, and a corresponding collector from the collector library, and enters the parameters for the system location and further system components. The program user interfaces are designed to be user friendly. Experienced Windows users will not require a lengthy familiarization period. The costs for such programs range between 200 and 1500 Euro.

T*SOL

In the category of timeseries analysers, T*SOL is the most widely used program throughout German-speaking countries and in Europe. It is also popular due to its user-friendliness.

The program was brought onto the market in 1993, and in 2005 diversified its product range. It is now available in different program versions: T*SOL Express, T*SOL Professional (Pro) and T*SOL Expert. Within the framework of the EU-project Solcamp (www.solamp.eu), an ancillary version was developed, called T*SOL Camp.

The program versions integrate more than 150 climate datasets of locations in Germany, around 500 climatic data records for Europe and, additionally, 275 worldwide data records.

Around 3000 worldwide climate data points are available, and additional climate data sets can be inputted using the climatic data module MeteoSyn integrated within T*SOL Pro and T*SOL Expert. New program enhancements such as the swimming pool module and SysCat module are available, as is the supplementary module for T*SOL Expert that allows the calculation of local heat supply systems.

In addition, there is an online calculator available free of charge at www.valentin.de.

T*SOL Express version 1.0 (R2) is a quick design program for craftsmen and sales representatives, which determines the number of collectors and the yield of the solar thermal system. T*SOL is available in German and English and distinguishes between five types of systems and seven types of collectors.

T*SOL Camp is a design program specific to thermal solar plants used for domestic water heating on camping sites.

By simulating the solar thermal system during camping season, the system's yield, coverage ratio, and utilization ratio can be calculated, as well as the expected energy savings and environmental benefits.

Version 1.1 (R3) of T*SOL Camp is currently available in different languages (German, English, Spanish, Croatian, Italian, Polish, Portuguese, Slovenian) and contains four solar systems as well as seven product-neutral standard collector types.

The dynamic simulation programs T*SOL Pro and T*SOL Expert, both available in version 4.5, are available in German, English, French, Spanish and Italian, and contain over 54 different solar systems in the basic version as well as around 900 collector data sets.

Both programs can be extended by incorporating a swimming pool module with 17 solar systems and a large solar module (SysCat) with a further 14 system designs.

With the help of a shading editor, a detailed shading analysis is possible. Output values include temperatures, energies, efficiencies and the proportion of solar coverage, which can be output as tables and graphs on an hourly basis.

While T*SOL Pro is used primarily by engineers, planners and installers for the design and optimization of solar thermal systems, T*SOL Expert is suited to experts who are interested in detailed analysis of physical change of states or of the components of solar thermal systems. Profitability and emission calculations are integrated. In a clear overview, it is possible to compare different versions with each other.

Some manufacturers offer their associate partners company versions of T*SOL, with program functions identical to those of the Pro-Version, but with libraries exclusively confined to their own components (collectors, storage tanks, boilers).

Additionally, there are several manufacturers whose system components have been incorporated into the regular professional version. A third version of the program consists of special company versions, based on the modified design assistant available in the program since version 4.0, and containing the components of the company and a reduced number of locations.

As previously mentioned, the first version of T*SOL Expert 4.5 with the module 'solar local heating supply' appeared in 2008. This program module was developed with support from the BMU, within the framework of the project Solar Thermal Energy 2000plus, and in collaboration with ZfS Rational Energy Engineering GmbH. The program module contains the following capability characteristics:

- Up to six collector systems, connected with the energy source via a freely definable solar grid, are configurable.
- The energy source consists of a solar buffer tank and the boiler plant.

The program contains three versions:

- 1 Bivalent buffer storage with integrated support heating as solar buffer tank.
- 2 Monovalent buffer storage with a boiler connected in series.
- 3 Monovalent buffer storage with boiler buffer tank connected downstream.

The energy source can be connected using transmission stations to up to six different homes via a freely definable local heat grid.

For the transmission stations located at the homes, three versions are available:

- 1 Flow system for housing transfer stations.
- 2 Storage load system.
- 3 Storage load system with closed-circuit cooling and thermal disinfection.

All three versions contain a central heating supply.

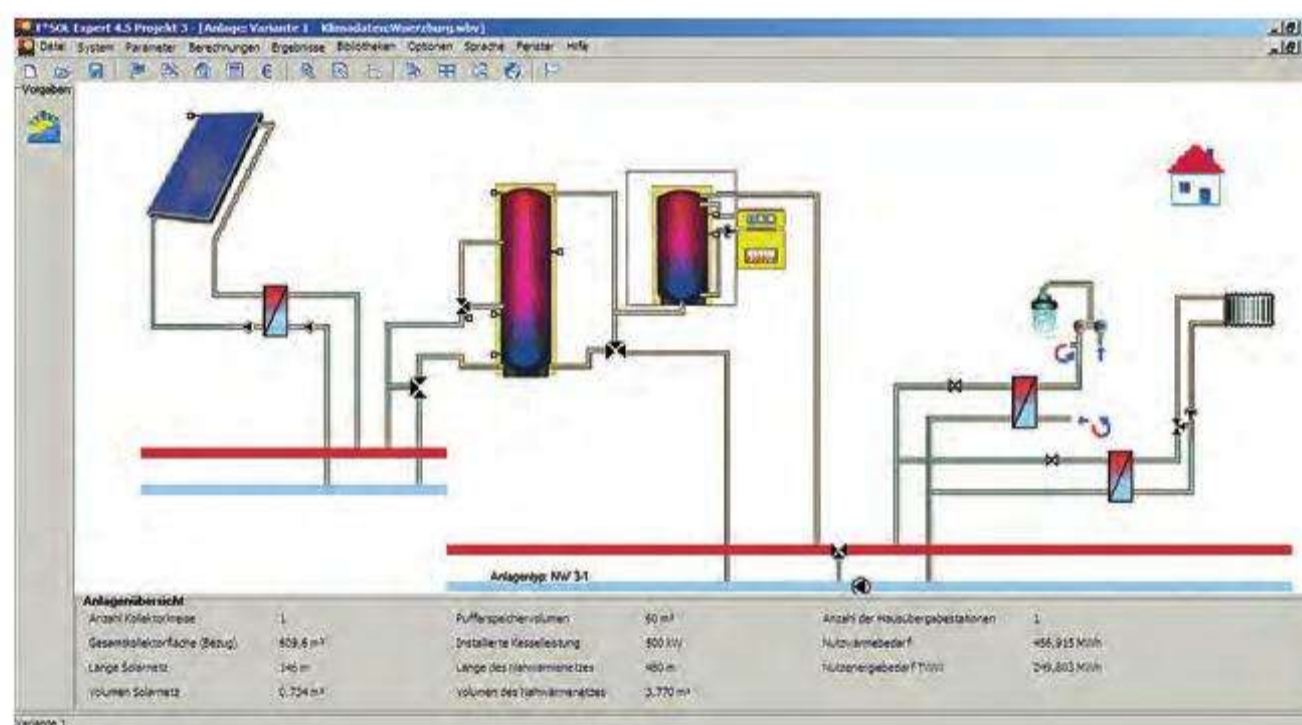

Figure 10.7.
Screenshot of T*SOL Expert 4.5

POLYSUN

The Swiss Windows program Polysun 5 has been developed and maintained by the company Vela Solaris since 2007. Vela Solaris is a spin-off of the SPF Institute for Solar Engineering at Rapperswil Technical University. The company was founded to market and develop commercially the Polysun software package. In close cooperation with the SPF, Vela Solaris conducts research in the area of solar simulation.

Polysun 5 is a software instrument used for simulating and optimizing solar thermal systems. It is available in the following versions: 'Light', 'Professional' and for 'Designers'.

The Light version is targeted to amateurs, architects, installers and those with an interest in solar energy; it enables the comparison of different system variants on the basis of simple parameters. The Professional version allows the variation of all system variables in order to optimize solar yield. The Designer version is aimed at solar system manufacturers and energy planners who are interested specific solutions.

The program integrates hydraulic systems from SPF with around 80 circuit variants, two country-specific systems for France, China, Spain and Sweden, three typical systems for the United States, as well as approximately 60 manufacturer-specific systems from the companies ProSolar, Rotex and Sonnenkraft. Using the designer version, these systems can be assembled according to the modular design principle: it is possible to select the desired components from a list of approximately 18 solar thermal parts, and then place and connect these on the construction surface.

By double clicking on a component, it becomes associated with a catalogue element and can be enhanced with other characteristics. Furthermore, SPF is developing supplement modules for new components which can be downloaded from the Internet and inserted in the system.

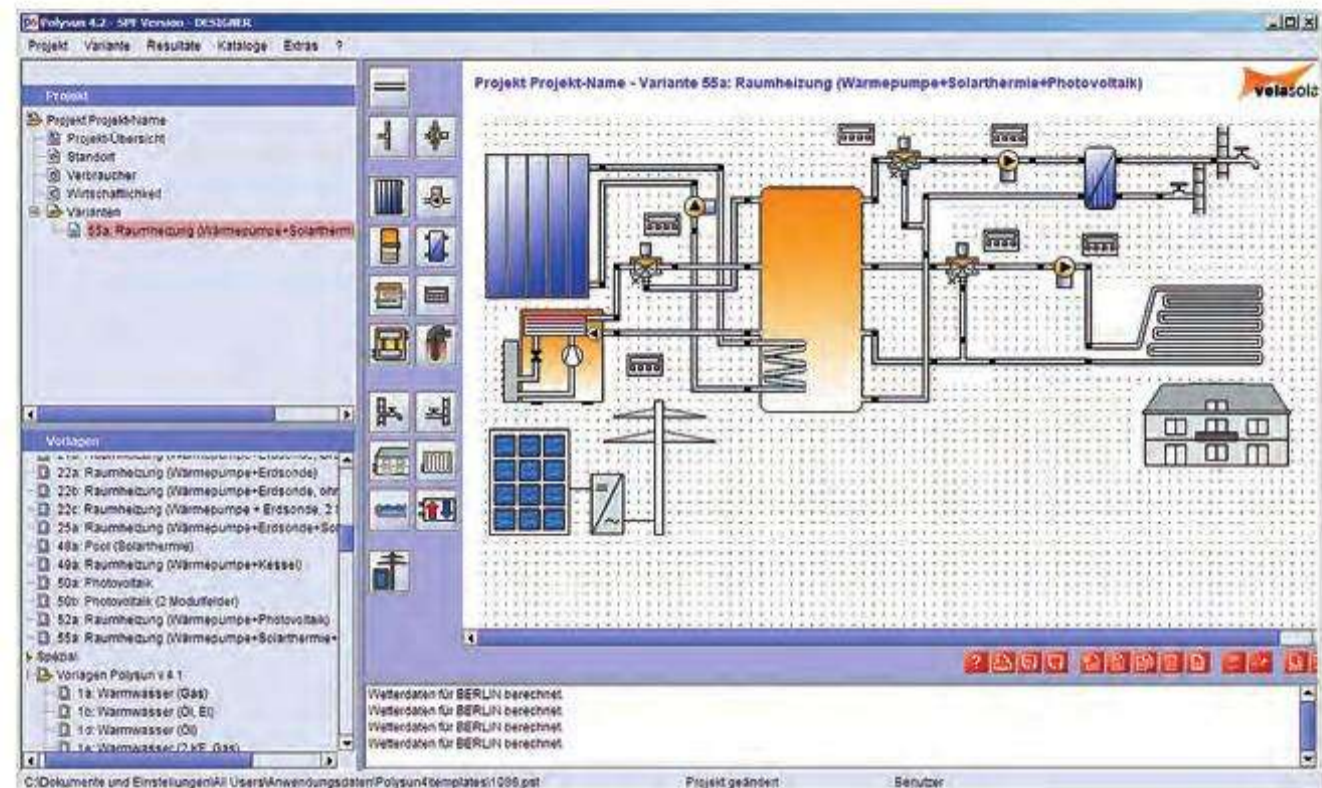

Figure 10.8.
Screenshot of Polysun 4.2 Designer

Polysun combines know-how from different well-known simulation programs such as Helios, which is run by the company EMPA and enables dynamic building simulation; TubeCalc, which is applied for calculating pressure losses in piping; and Meteonorm (by Meteotest), which consists of a climate database that incorporates around 6300 Meteorological locations, where new locations can be interpolated with the help of coordinates. Polysun 4 is available in several languages: German, English, French, Greek, Italian, Spanish, Portuguese, Czech and Chinese.

Starting with version 4.2, it has become possible to simulate photovoltaic systems, and also to do so in combination with hydraulic systems; thus, for example, it becomes possible to operate a heat pump using solar electricity.

Both solar thermal and photovoltaic systems can be simulated using a uniaxial or biaxial tracking device. It is therefore also possible to simulate several collectors or module fields of different orientation.

It is also possible to simulate brine/water heat pumps and water/water heat pumps with the sampling points determined in EN14511 or EN255. The simulation of geothermal probes is carried out according to a detailed model and by taking all significant influencing factors into consideration.

As a further feature, the designer version is used to simulate process heat and the heating grid component (thermal demand), which helps simulate freely definable loads.

By the end of 2008, Polysun 4.2 is to be extended to include chillers for solar cooling as well as process heat systems.

GETSOLAR

GetSolar is a scientifically approved, tried and tested PC program for the simulation of combined solar systems and solar thermal systems for domestic water heating. Version 9.1 is its most recent available version. The program currently contains eight system variants which can be further modified in detail (e.g. with/without swimming pool, low-flow solar circuit, anti-legionella controller).

The solar climate database incorporates over 250 locations in Germany and neighboring European countries and can be extended using the program WetSyn. WetSyn generates irradiation and temperature data for air temperature and for direct and diffuse solar radiation on an hourly basis.

GetSolar is used for the rapid simulation of solar collector systems, but can also be used for quantifying excess amounts of solar heat for room heating. Temperature profiles can be displayed in detail.

As well as containing weather data records (monthly average values), the program also integrates a library containing data for over 230 collectors. Additional program features include a shading editor and the possibility to work with collector arrays of varying orientation. GETSolar also integrates a function for calculating solar yields in accordance with EnEV and DIN 4701-10 with an interface to the software Energy

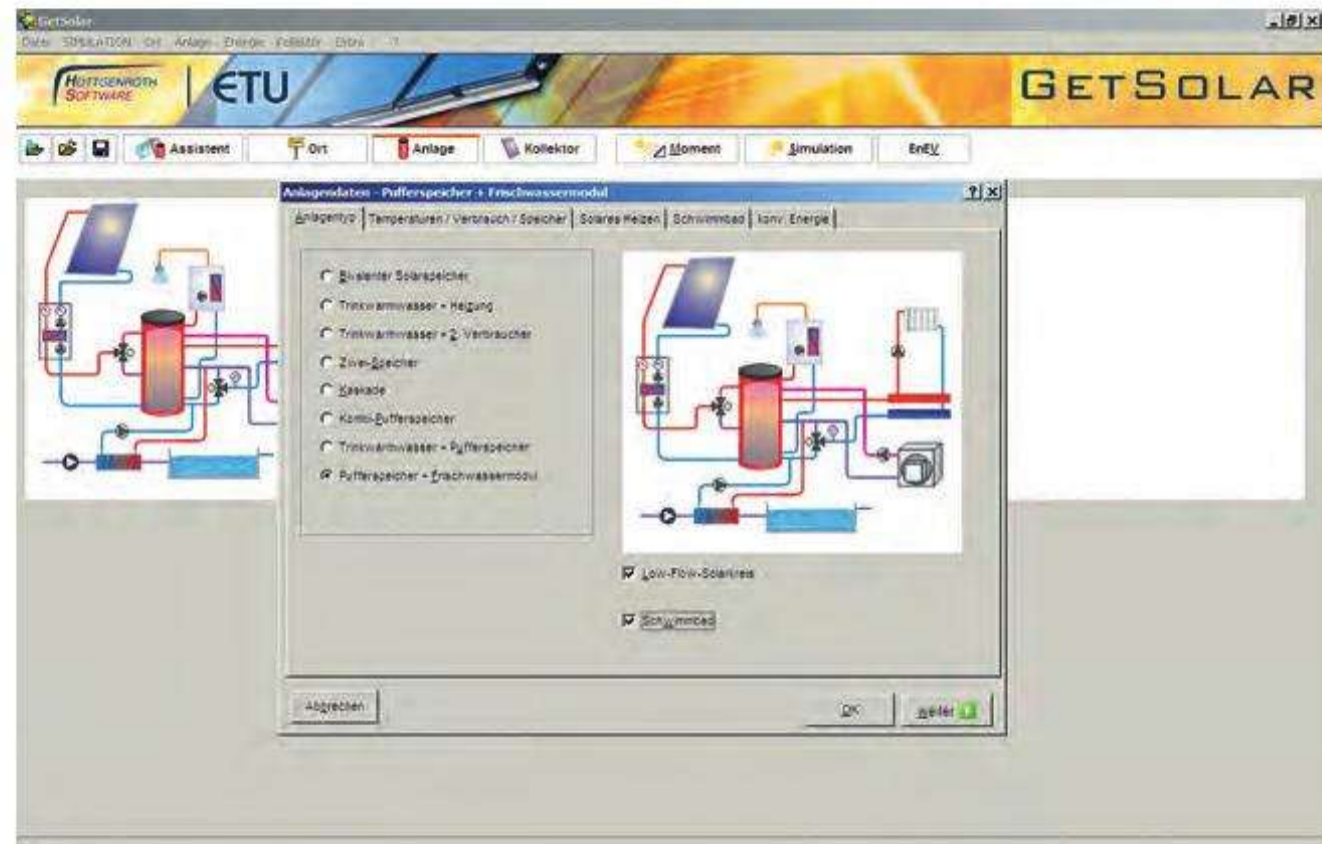

Figure 10.9.
system configurations of GetSolar 9.1

Consultants Professional (starting with version 5.09e), produced by the company Hottgenroth, who are largely responsible for the marketing of GetSolar.

Calculations of all relevant operating parameters such as solar altitude, insolation, ambient temperature, collector efficiency, losses within the solar circulation system, utilization, storage losses, and the resulting energy flux and system temperatures are possible up to 131,400 times per year. For this, the simulation program uses the real-time hourly values for direct and diffuse radiation generated by WetSyn, as well as data on air temperature.

The results can be copied onto the clipboard for further processing in other programs. Special features include design of the expansion vessel, calculation of the collector stagnation temperature, consideration of single or twin-axis tracking and various inclinations for absorbers in evacuated tube collectors. The consumption profile can be defined for a standard day. The program cannot carry out economic viability calculations. It requires a high level of computer knowledge from the user and has a good cost-performance ratio.

The work structure of GETSolar provides fast answers to issues regarding dimensioning, and offers on-line expertise to train solar beginners, as well as advisory services for professional customers.

10.1.3.3 SIMULATION SYSTEMS

If, for large systems with surface areas bigger than 100 square metres or particularly complex systems, one reaches the limits of timeseries analysis programs and their rather constrained interfaces, the use of dynamic simulation systems becomes necessary.

Their flexibility allows for the simulation of almost any system configuration and operating conditions. This versatility is however matched by increased requirements on the part of the user, resulting in longer familiarization periods (months).

The programs facilitate the solving of relevant differential equations, often contain a multi-zone building model and are appropriate for complex interactions of heating, active and passive ventilation or cooling.

TRNSYS

The Microsoft Windows program TRNSYS is certainly the most well-known tool and the market leader among simulation systems. The most varied thermal building and technical energy system simulations can be carried out with this program. The main features of the program are its flexibility and its numerous predefined systems and standard components. TRNSYS is a widely used simulation program that was developed in 1974 at the solar energy laboratory of the University of Wisconsin, Madison, USA. The program is available in English and French. Interfaces to other programs (CAD and various simulation programs) are also provided. For the experienced computer user, the source code (FORTRAN and C++) of the program

can be edited, and the mathematical descriptions are accessible. Apart from superior computing capabilities, the user should also be knowledgeable in the area of solar structures and systems technology, and have a profound understanding of simulation models. Its use within many completed buildings has proved the performance and accuracy of TRNSYS simulations. The target groups for the program are larger planning offices as well as firms specializing in building and system simulation. TRNSYS is also used extensively in universities and colleges and for research and development. In the area of solar thermal systems, the various types of collector are prefabricated and can then be parameterized. Certain solar system examples are also included in the standard package. Thus, thermosyphon systems, various heat exchangers (counter, parallel flow and cross-flow etc.), concentrating collectors, stratified and stone-filled storage tanks can for example all be simulated.

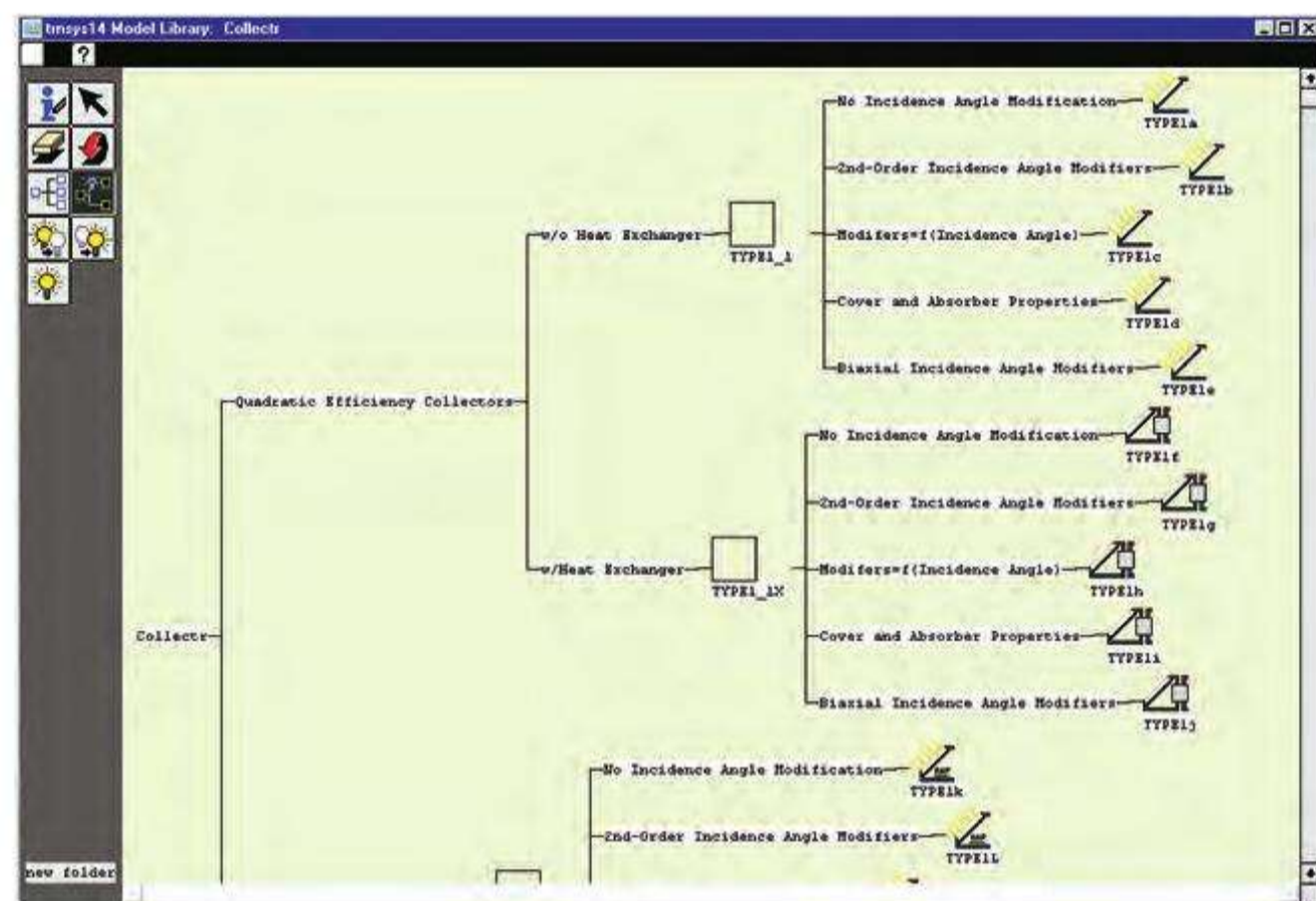

Figure 10.10.
Collector characteristics represented in a tree diagram in TRNSYS

The most significant innovation is the add-on product TRNSYSlite, which renders the complex program TRNSYS applicable for simpler simulations, without the complete input of all necessary parameters. This innovation is realized through pre-defined components and an intuitive user guide.

INSEL

The simulation program INSEL (engl. Island), developed at the University of Oldenburg, is a modular simulation environment which can simulate, visualize and monitor solar energy systems. The graphical user interface HP VEE facilitates graphically connecting different blocks. The user creates the installation configuration which can be simulated with the help of a graphic editor in the form of a block diagram. In doing so it employs available building-block libraries of radiation calculations as well as components for thermal and electrical energy systems.

More than 300 sets of parameters of the most standard flat-plate and vacuum tube collectors and six absorption refrigerators currently available on the market are calculated – the constant update of databases enables a precise simulation of solar thermal systems for heating and cooling.

Grid-connected photovoltaic systems, photovoltaic hybrid- or pumping systems equipped with batteries and auxiliary power units can also be simulated, as well as other electrical systems such as wind turbines, fuel cells, and solar thermal power stations.

INSEL also consists of a radiation database, which covers monthly average values of approximately 2000 world-wide locations over decades from which hourly time series can be generated for insolation, temperature, humidity, etc.

INSEL offers well-documented, flexible simulation building blocks with a vast number of applications, from solar heating and cooling, photovoltaics and other areas,

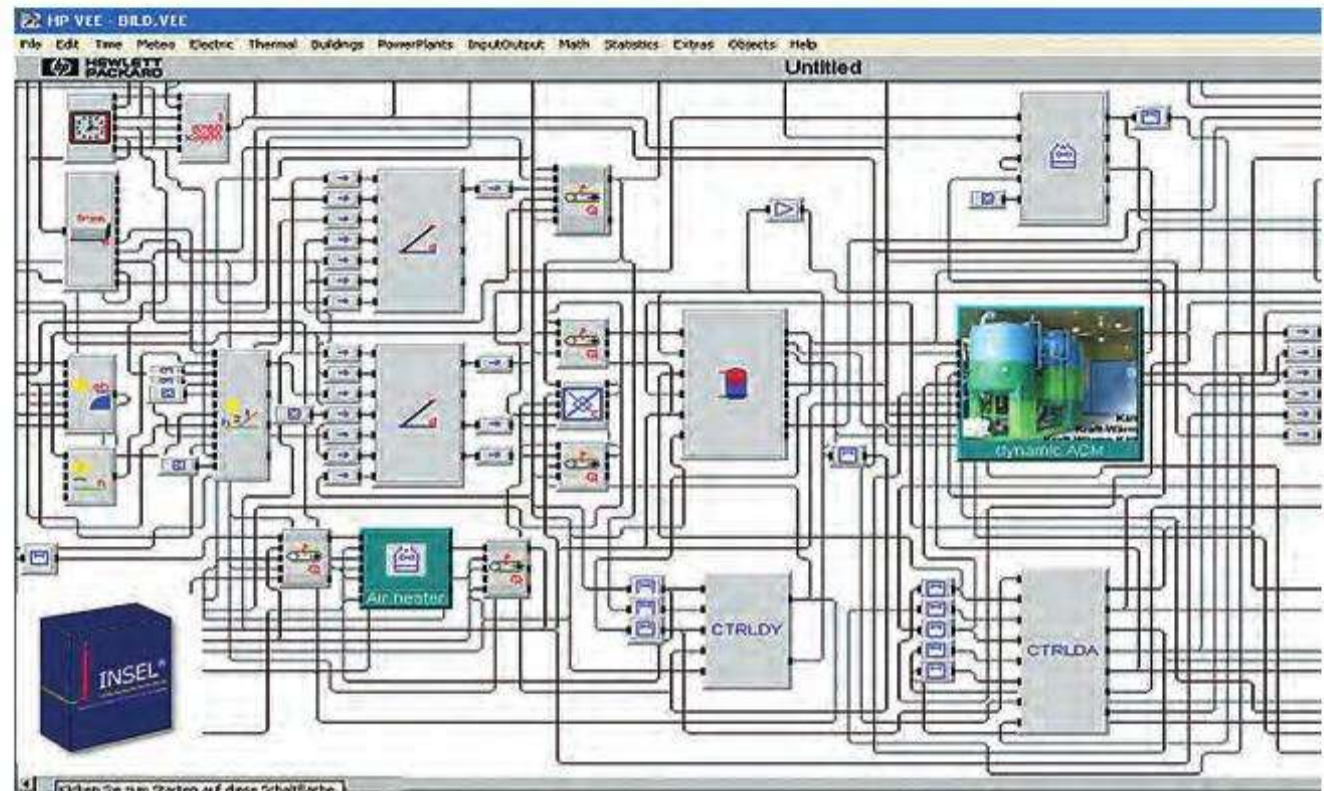

Figure 10.11.

which are used by planners, manufacturers and scientists. The completely revised version INSEL 7 is being further developed and distributed by the Stuttgart company doppelintegral.

INSEL is specifically intended for research purposes, for the simulation of special applications, for detailed yield analysis and for professionals who require a high level of flexibility.

DK-INTEGRAL

Using a derivation of the simulation tool DK solar, developed in the early 1980s, Delzer Cybernetics has designed a successor, DK-INTEGRAL, considered essential for holistic building and solar system planning.

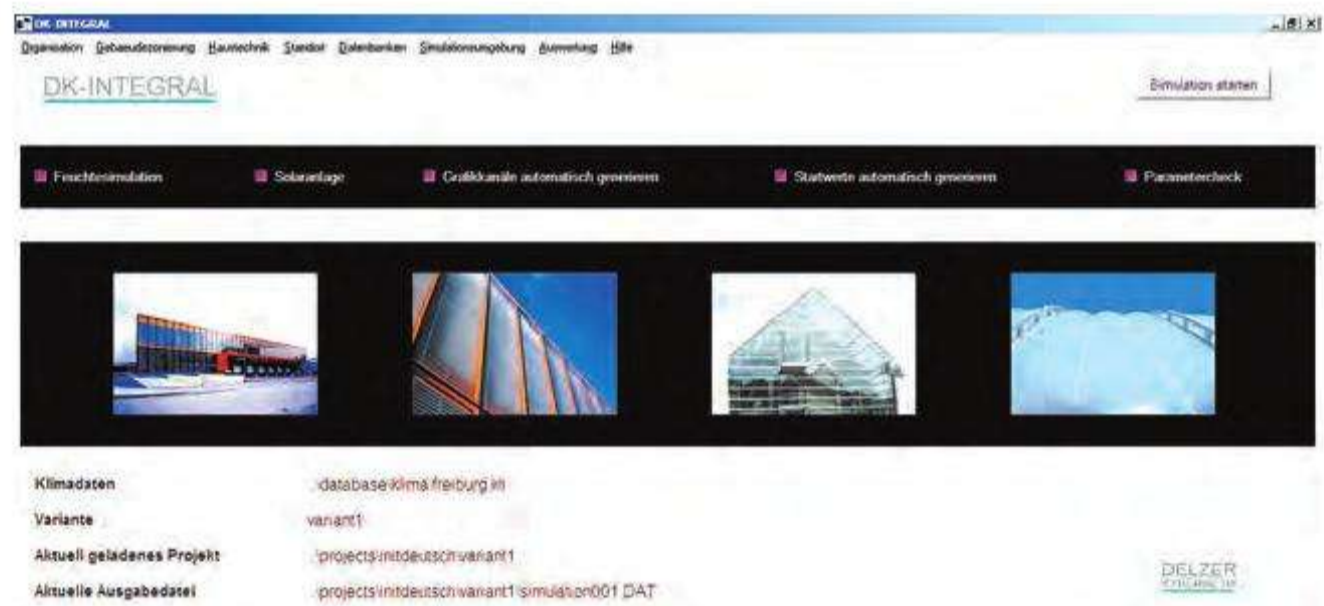

Figure 10.12.
User Interface of DK-INTEGRAL 0.1

Energy efficient buildings can be dynamically simulated while taking into account the integration of solar thermal systems. Coupled simulation of heat and moisture transport within building components is also possible.

With the help of DK-INTEGRAL it is possible, for example, to detect condensation and mould formations in double skin facades and wall claddings, and to develop preventative measures.

A dynamic simulation considers, in chronological sequence, all the parameter interactions that are of relevance for the energy efficiency of a building, such as system engineering, climate, building structure and user behaviour. Using these prerequisites, solar thermal systems are dimensioned in a meaningful manner and are integrated harmoniously into the building concept.

DK-INTEGRAL supports the sustainable planning of all system components.

To optimize the energy yield, solar thermal energy can be coupled with the following systems:

- heat pumps;
- geothermal energy;
- combined heat and power ;
- thermo-active building element systems.

In doing so, the individual systems are not only interconnected, but are also coordinated in their operation mode. In the dialogue box 'Storage Load' it is possible to determine with which priority the three storage systems – solar storage, building mass and geothermal – are heated. Furthermore, the operating mode of integrated CHPs (i.e. heat or electricity load) can be defined.

For the dimensioning of a solar thermal system, different types of collectors, tubes, heat exchangers and storage types are available or can be created by the user. The collectors can either be integrated into the building cladding surface or installed with rear ventilation. Additionally, the collectors can be elevated at any angle or even be equipped with a twin-axis tracking device.

Up to four solar storages can be integrated into a system. The clear input matrix allows the comparison of specific system parameters within different simulation models.

Table 10.1.
Characteristics, costs and reference
addresses of simulation programs

	GetSolar	F-Chart	Polysun 4	SW-Simu	T*SOL	TRNSYS	DK-Integral	Smile
Update Version	9.1	7.03	Light 4.1, Pro 4.1, Designer 4.1	3.03	Express 1.0, Pro 4.5, Expert 4.5	16.0	0.1	1.1
Market introduction year	1993	1988	1994	1988	1993	1974	1980	1997
Area of application	Simulation of solar thermal systems with/without back-up heating	Design of standard solar thermal systems without back-up heating in single and two family homes	Solar thermal domestic water systems for EFH/MFH with back-up heating and simulation for large solar systems, swimming pools and buildings	Design of solar thermal systems for open air swimming pools	Domestic water systems for EFH/MFH with back-up heating as well as large solar systems and swimming pools	Building simulation, solar thermal domestic water systems, seasonal heat storage, etc.	Manifold simulations of building and systems including solar thermal and photovoltaic systems, heat recovery, hygrocasts	Coupled building and system simulation, complex energy-technical systems
Characteristics/further applications	Timeseries simulation program for detailed analysis of solar thermal systems, simplified capture of parameters to ease handling	Well-laid out, fast and user-friendly program for the general analysis of small solar systems	Dynamic timeseries simulation program for detailed analysis of solar thermal systems, optimization of orientation of solar collector, optimization support for circulation pumps, and automatic calculation for land requirements through solar savings target setting	DOS-program, well-laid out and user-friendly timeseries simulation program for the dimensioning of larger open air swimming pools	Time step simulation program for detailed analysis of solar thermal systems, monitoring additional module swimming pool sizing; additional module for the calculation of large solar systems	Dynamic, modularly-constructed simulation system for buildings and solar systems, to analyse the behaviour of systems with respect to active and passive solar energy usage, or the behaviour of systems for the rational usage of energy, additional program TRNSYSite 5.0	Dynamic building and solar system simulation, complete climate generator	Operating software UNIX/LINUX, object-oriented model description, nearly optional complex simulation models
User support								
Hotline	Included in the program free of charge	Included in the program free of charge	Included in the program free of charge	Included in the program free of charge	Included in the program free of charge	Included in the program free of charge	Yes	Yes
Demonstration version	Internet	Internet	Internet	Internet	Internet	Internet	Yes (temporary)	Yes
Internet download	KU, PU	KU	KU, PU	–	KU, PU	KU, PU	Yes	Yes
E-mail newsletter	Yes	–	Yes	–	Yes	Yes	–	–
Internet user forum	–	–	Yes	–	–	Yes	–	Yes
Trainings/Seminar	–	–	Yes	–	Yes	Yes	Yes	Yes
Costs (single licence with VAT included in German speaking countries)	355.81 EUR	297.50 EUR with two additional weather regions, Austria, 46 locations, 29.75 EUR Europe, 62 locations, 29.75 EUR	Light Version * 99.00 EUR Professional Vers. * 499.00 EUR Designer Vers. * 1,499.00 EUR Educational Vers. ** 100.00 EUR * inclusive 1 year update subscription ** acquisition of at least 10 licences and 1 Designer version	595.00 EUR Other weather regions contain approx. 20 locations for 59.50 EUR, All regions contain approx. 90 locations, for 155.85 EUR. Export data as ASCII-files 234.95 EUR	Express 1.0, 160 EUR, Professional 4.4, Basic Version 580 EUR; Professional 4.4, Set*, 980 EUR; Expert Basic Vers. 580 EUR; Expert Set* 1,280 EUR * Additional modules: Swimming pool 245 EUR Large solar systems 290 EUR	5,070 EUR (Industry, research) or 4,400 EUR (10 licences for colleges); TRNSYSlite 1,260 EUR, (Industry, research) or 1,260 EUR (10 licence for colleges)	4,250 EUR including 1 training day, university and colleges pay 20% of the catalogue price 850 EUR	500 EUR, building model 500 EUR

Table 10.1. continued

User support								
Costs (single licence with VAT included in German speaking countries)	355.81 EUR	297.50 EUR with two additional weather regions. Austria, 46 locations, 29.75 EUR Europe, 62 locations, 29.75 EUR	Light Version * 99.00 EUR Professional Vers. * 499.00 EUR Designer Vers. * 1,499.00 EUR Educational Vers. ** 100.00 EUR * inclusive 1 year update subscription ** acquisition of at least 10 licences and 1 Designer version	595.00 EUR Other weather regions contain approx. 20 locations for 59.50 EUR, All regions contain approx. 90 locations, for 155.85 EUR. Export data as ASCII-files 234.95 EUR	Express 1.0, 160 EUR, Professional 4.A, Basic Version 580 EUR; Professional 4.A, Set*, 980 EUR; Expert Basic Vers. 580 EUR; Expert Set* 1,280 EUR * Additional modules: Swimming pool 245 EUR Large solar systems 290 EUR	5,070 EUR (Industry, research) or 4,400 EUR (10 licences for colleges); TRNSYSlite 1,260 EUR, (Industry, research) or 1,260 EUR (10 licence for colleges)	4,250 EUR including 1 training day, university and colleges pay 20% of the catalogue price 850 EUR	500 EUR, building model 500 EUR
Middle School/ High School Version	Yes (110 EUR)	Yes	Yes	Yes	Yes	Yes	Yes	Free of charge
Languages	G, E, F, I	G	G, E, F, I, S, Po, T, CH	G	G, E, F, I, S	E	G	E
Process water systems/1storage	Yes	Yes	Yes	–	Yes	Yes	Yes	Yes
Process water systems/2storages	Yes	–	Yes	–	Yes	Yes	Yes	Yes
Solar back-up heating	Yes	–	Yes	–	Yes	Yes	Yes	Yes
Stratified storage tank	–	–	Yes	–	Yes	Yes	Yes	Yes
Combined storage	Yes	–	Yes	–	Yes	Yes	Yes	Yes
Low-flow system	Yes	–	Yes	–	Yes	Yes	Yes	Yes
Heat-pump	–	–	Yes	Yes	–	Yes	–	Yes
Swimming pool	Yes	–	Yes	Yes	Yes (with additional module)	Yes	–	Yes
Thermal building simulation	–	–	Yes (Heios)	–	–	Yes	Yes	Yes
Local solar heat grid	–	–	Yes	–	Yes	Yes	–	Yes
Other technologies	–	–	Yes	–	–	PV	PV, CHP, GEO, EW, TWD, Hydro	PV, GEO, PV, GEO, EW
Radiation generator	Yes	–	Yes	–	–	Yes	Yes	Yes
Shading	Yes	–	Yes	–	Yes	Yes	–	Yes
Cost-effectiveness	–	–	Yes	–	Yes	–	Yes	Yes
Emission balance	Yes	Yes	Yes	–	Yes	Yes	–	Yes
Weather	250 DE, EU	100 DE 100 EU	Including all Swiss Townships, world-wide 6,300 meteorological stations	90 DE	150 DE 500 EU 275 Int	North America	100 (EU) monthly average values	–
Components (quantity)	230 C	141 C	259 C, 505 S, 21 B, 10 U 27, P, 97 Pip and many other catalogues	C 2 types	More than 600 C from different manufacturers for the storage tank, heat exchanger, boiler	Different 'decks', data sets are purchasable	Freely editable	Freely editable solar systems can be downloaded
Import of components	Yes	Yes	Yes	Yes	Yes	Yes	Yes	–
Weather data import	–	–	Yes	–	Yes	Yes	Yes	Yes
Plausibility check	Yes	Yes	Yes	Yes	Yes	Yes	Yes	–
Design support	Yes	Yes	Yes	Yes	Yes	Yes	–	–
Output of results (formats)	Clipboard, Printer	Clipboard, Printer	Textfile, Printer	Clipboard, Printer	Clipboard, Printer	optional	ASCII, Printer	ASCII, Printer
Temporal resolution of the results	Hours, month, year	month, year	Hours, month, year	Hours, month, year	Hours, month, year	optional	opt ion al	optional
Sales department/contact	ETU Software GmbH Von-Hünfeld-Str.3 Buchenstraße 38 D-50829 Köln Tel: 02 21-709 93 4000 Fax: 02 21-709 93 4001 service@etu.de www.etu.de	IST Datentechnik GmbH Ritterweg 1 D-79400 Kandem Tel: 0 76 26/91 54-0 Fax: 0 76 26/91 54-30 datentechnik@istnet.de	Vela Solaris AG, Herrenberg 35 CH-8640 Rapperswil Tel: +41 (0)55 220 7100 Fax: +41 (0)55 220 7109 info@velasolaris.com www.velasolaris.com	IST Datentechnik GmbH Ritterweg 1 D-79400 Kandem Tel: 0 76 26/91 54-0 Fax: 0 76 26/91 54-30 datentechnik@istnet.de	Dr. Valentin EnergieSoftware GmbH Stralauer Platz 34 D-10243 Berlin Tel: +49 30-588 439-0 Fax: +49 30-588 439-11 info@valentin.de www.valentin.de	Transsolar Energietechnik GmbH Curiestraße 2 D-70563 Stuttgart Tel: +49 711-67 97 6-0 Fax: +49 711-67 97 6-11 transsolar@transsolar.com www.transsolar.com	Delzer-Kybernetik GmbH Tüllinger Straße 90 D-79536 Lörrach Tel: +49 7621-9577-0 Fax: +49 7621-9577-20 info@delzer.de www.delzer.de www.dk-integrat.de	info@smilenet.de www.smilenet.de

Note:

Hotline: free of charge = signifies that only telephone costs arise.

Internet download: KU = Update data sets, PU = Program update (patches, new versions).

Costs: Costs include VAT, postal charges, and packaging.

Other technologies: WI = Wind, Photovoltaic, CHP = Combined Heat and Power Plant, GEO = Geothermal energy, EW = Heat Exchanger, TWD = Transparent, HY = Hypoc aust.

Languages: G = German, E = English, F = French, I = Italian, S = Spanish, Dk = Danish, P = Polish, Sl = Slovenian, Sr = Serbian, H = Hungarian, I.V. = underway.

Weather: DE = Germany, A = Austria, E = Europe, k.e. = Available for purchase.

Components: C = collectors, B = Building types, S = Storage, U = Usage profile, P = Pumps, Pip = Pipes.

10.1.4 Evaluation of simulation results

For solar thermal systems it is key to determine relevant planning criteria such as hot water and heating demand. If consumption or demand changes in reality, then the operation results inevitably deviate from the simulation results. The selection of applicable system circuits and their components is similarly important, but has a less significant influence on the solar yield for example.

The more complex a solar system, the more extensive the input masks in the program. Unfamiliar users in particular should understand the meaning of the parameters before entering them. Most programs offer suggestions and guidelines when opening the input mask; however, incorrect entries can never be excluded and might thus lead to false simulation results. Some programs give warnings for unusual entry data, but a simulation is often still possible. The difficulty for developers and programmers lies in the fact that the highest possible variety of choices is offered to the user, while at the same time endeavouring to keep the handling of the program as simple as possible. In general, the help function can provide assistance here. Some solar systems can only be meaningfully optimized through variations in simulation modelling, if the user understands what effect 'turning the knobs' might have on the final result. The result should always be rechecked with experiential data.

A solar system with a specific simulated yield of less than 200 kWh/m²a is usually incorrectly mounted, constructed or dimensioned. Also, when results are too good, for example a specific yield of above 600 kWh/m²a, they should be questioned critically.

10.1.5 Supplementary programs and data sources

This category includes programs for irradiation calculation and shading analysis, as well as component libraries and weather data. Programs that complete location data by determining the radiation data, by displaying diagrams of the sun's orbit or by facilitating shaded analysis include horizON, METEONORM and SUNDI.

Additional weather data are available online.

SIMULATION WITH SHADING

Many of the programs described in section 10.1.3 are presently working with shading editors. The T*SOL program generates easily interpreted graphic images, which show in the shaded and unshaded irradiation on collector surface areas. The shading can be entered either through the click of a mouse on a diagram including angles of the sun's height at different seasons, or via coordinates (distance, height from the collector, direction towards the collector). With the latter variant, the result will be more precise. Some developers are thinking about the possibility of using digital pictures by which the actual shading parameters could be imported into the program.

In contrast to photovoltaic systems, the impact of partial shade is less severe for the yield of solar thermal systems, depending on time of day and season. Collectors are also substantially more effective at converting diffuse radiation into energy. Moreover, shading does not jeopardize the reliability of solar thermal systems.

In most cases, shading losses can be compensated by expanding the collector surface area; although the efficiencies will be reduced, the desired coverage ratio will be achieved at relatively little extra cost.

Comparative calculations can for example illustrate the influence of a 20-year-old birch tree on a solar system's yield, and this can be shown to the consumer or client.

HORICATCHER

HORICatcher is a hardware and software package developed by the company Meteotest (Bern, Switzerland). Its aim is fast and efficient on-site horizon capture. Used in tandem with the evaluation program, it can identify and evaluate at the location obstacles that constrain sunshine hours and irradiation. The software facilitates the interpretation of pictures taken using the Nikon Coolpix 4100 digital camera. The hardware package includes the camera and the fixture with a horizon-mirror. HORICatcher's evaluation program serves to de-skew the picture and to calculate the sun's path. The program also features an interface with METEONORM to precisely calculate solar radiation.

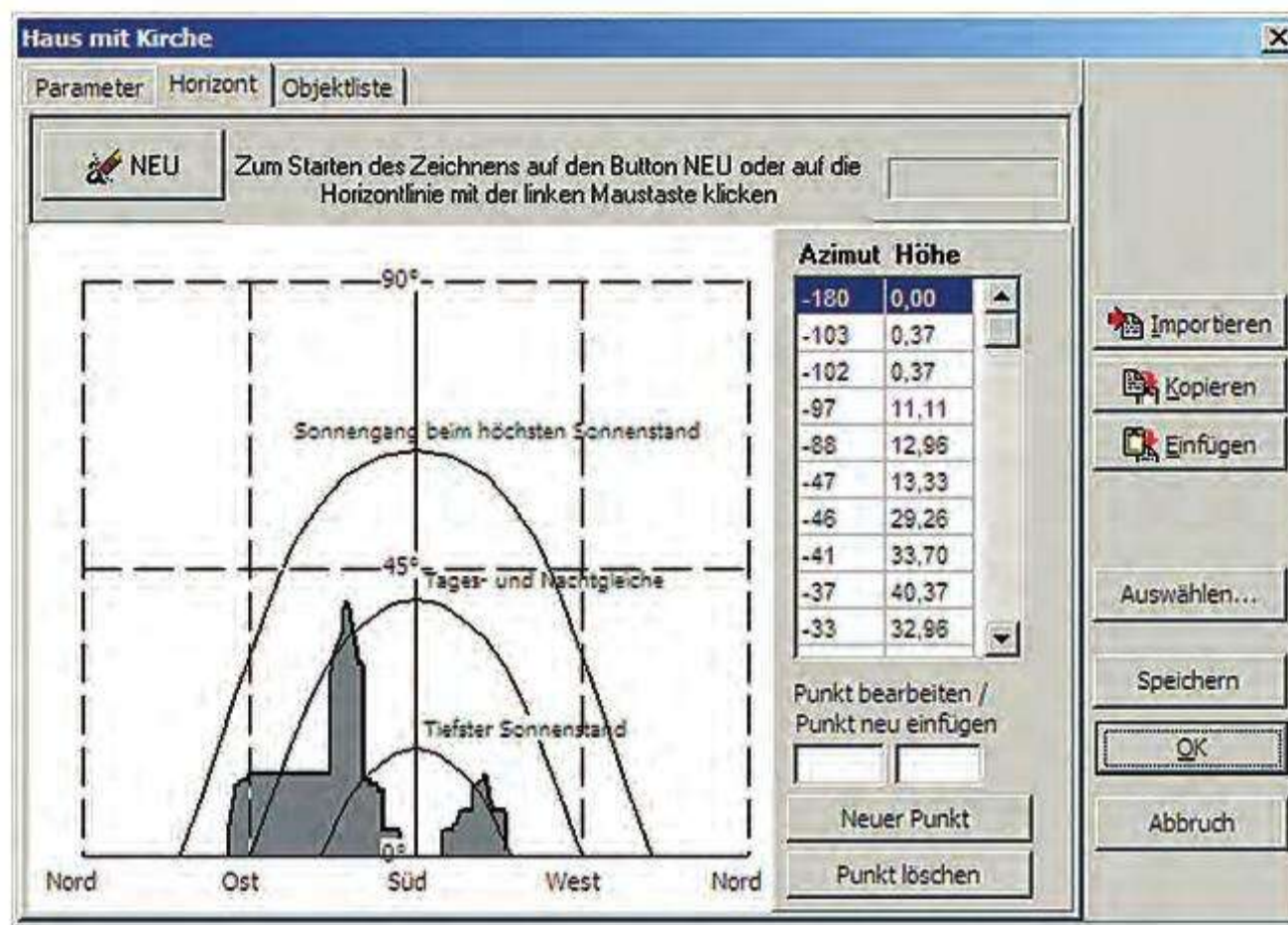

Figure 10.13. Shading editor of T*SOL



Figure 10.14. Shading capture using a horizon-mirror and HORIcatcher's user interface

HORIZON

The software horizon, latest version 2.0, is currently distributed by the Office of Energy in Zurich, Switzerland. The main focus of the program is the calculation of the horizon line as well as the solar path. Digital pictures are used as a basis. In addition, the Office of Energy offers the tripod attachment 'panorama master', in order to facilitate the process of taking 360° pictures of the horizon. The horizonON processing and calculation software assembles the digital photos in a precise and consistent panorama image, and then calculates the horizon line. This can then be printed using the printer function or exported into one of the following program formats: METEONORM, T*SOL, PV*SOL or PVSYST. The user interface is simple and clearly structured. The software is suited for anyone who is interested in defining the exact horizon line almost effortlessly.

METEONORM

This well-known Windows program, most recently available in version 6.1, exhibits a newly designed user interface and consists of a worldwide climate database with more than 7700 weather stations, combined with a weather generator.

Meteonorm computes multi-year and current monthly average values as well as hourly values of a typical year. The database consists of measured monthly values of

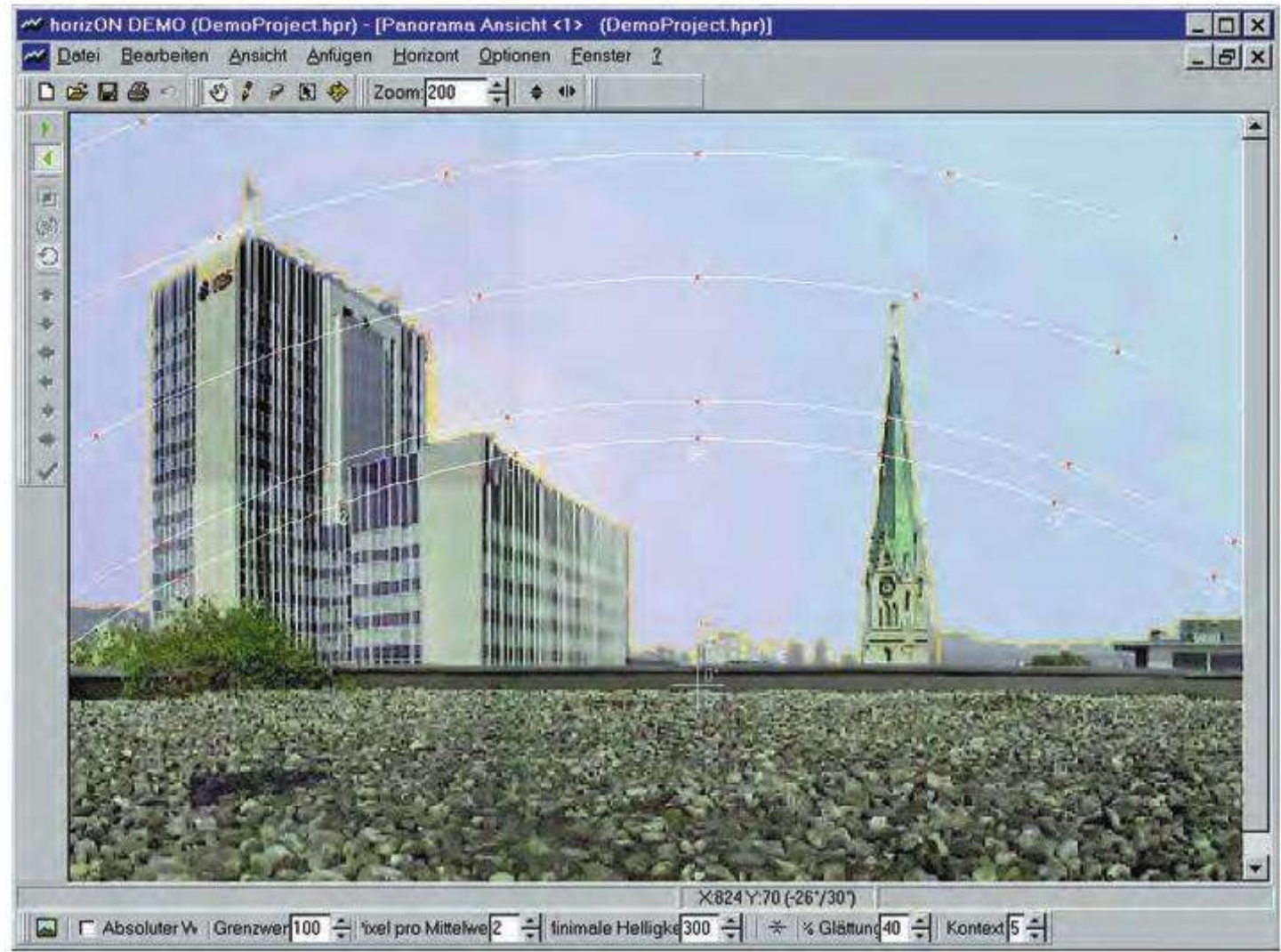

Figure 10.15. Defining the horizon line with the utility program horizon

global irradiation, air temperature, wind speed, wind direction, precipitation, sunshine hours, dew-point temperature and rainy days. A new feature is data in one minute resolution for radiation. In addition, with Version 6.1 the time period for temperature, humidity, rainfall and wind can be selected for the periods 1961–1990 and 1996–2005 and the data for global radiation has been updated for the timeframe 1981–2000.

For regions with lower densities of weather stations, satellite data can also be used.

Meteonorm contains worldwide diagrams of the sun’s path and can convert global direct irradiation to inclined surfaces. A shading editor helps consider the shading impact of the horizon. The results can be edited in 28 different predefined data formats or transferred to other programs as user-defined imports. Meteonorm is available in German, English, French, Italian and Spanish.

ONLINE WEATHER DATA

For research on weather data the following sites are recommended:



Figure 10.16. Choosing locations with the map contained in Meteonorm 6.1

METEOROLOGICAL SERVICES AND ORGANIZATIONSDeutscher Wetterdienst (DWD) www.dwd.de/World Meteorological Organization (WMO) www.wmo.ch/European Meteorological Society (EMS) www.emetsoc.org/**SOLAR RADIATION DATABASE AND INFORMATION**World Radiation Data Centre <http://wrdc-mgo.nrel.gov/>

NASA Langley Atmospheric Sciences Data Center

<http://eosweb.larc.nasa.gov/sse/>Solar Radiation Resource <http://rredc.nrel.gov/solar/>

European Database of Daylight and Solar Radiation

www.satellite.com/

Photovoltaic Geographical Information System (PVGIS)

<http://re.jrc.ec.europa.eu/pvgis/>**10.1.6 Tools and utility programs**

Besides various simulation programs, there are also many smaller utility programs and tools which can offer assistance to daily tasks related to the dimensioning of solar thermal systems. Table 10.2 gives an overview.

The company-specific component tool CAS 200 facilitates the dimensioning and optimization of heat exchangers from the company Alfa Laval using various functional principles. Something similar is offered by the company SWEP with its program for designing heat exchangers, SSP. The program TubeCalc works independently from manufacturers and is used to compute pressure losses in solar circuits or other piping systems. It is provided on the SPF-Info-CD from the Swiss SPF Institute and is integrated in the program Polysun.

Figure 10.17.
Input menu in TubeCalc

Table 10.2.
 Characteristics, costs and reference
 sources of utility programs

	Program	Sales and distribution	Brief description
Irradiation and climate	SUNDI Version 1.1 1999	Freeware, download at www.volker-quaschnig.de	Calculation and graphic display of worldwide sun orbit diagrams, including shading
	Meteonorm 6.0	METEOTEST Fabrikstrasse 14, CH-3012 Bern Tel. +41 (0)31-307 26 26 Fax +41 (0)31-307 26 10 e-mail: office@meteotest.ch www.meteotest.ch www.meteonorm.com Price 410 EUR	See p 290
	HORlcatcher	METEOTEST (see Meteonorm 6.0) Price 1.200 EUR incl. Digital camera (Sony DSC-W35), Camera fixture, horizon mirror and evaluation program for Windows-PC (image adjustment, sun path, Interface with METEONORM for exact calculations of solar irradiation)"	See p 289
	panoramamaster 2.0 horizon 2.0"	Package price 334 EUR energiebüro ag Hafnerstr. 60, CH 8005 Zürich Tel. +41 (0)43 444 69 10 Fax. +41 (0)43 444 69 19 Internet: www.energiebueero.ch Email: info@energiebueero.ch	Utility program for photographic transfer of shading in Horizon lines and import into simulation programs
	Meteosat and ConRad	University Siegen Meteosat: http://nesa1.uni-siegen.de (-Products) Price: Meteosat: Usage-dependent starting from 1 EUR; ConRad: free online download	Irradiation database of satellite data for Europe; ConRad: conversion of irradiation data for tilted surfaces
	Sombrero	University Siegen (see above) Price 220 EUR	PC program for time-dependent calculations of shading caused by objects for any oriented surface. It facilitates the quantitative determination of shading on collectors or windows caused by buildings, trees, bulges and horizon profiles.
	Meteosun 1.0	Institut für Solartechnik SPF Hochschule für Technik Rapperswil HSR Oberseestrasse 10 CH-8640 Rapperswil Tel.: +41-5522248-21 Fax: +41-5522248-44 Internet: www.solarenergy.ch Email: spf@solarenergy.ch Price: 131 EUR	With the help of Meteosun 1.0 it is possible to generate weather data for any location in the world, which can then be simulated in the program Polysun.

10.2 Material from manufacturers

10.2.1 CD-ROMs, documentation, product catalogues

Many manufacturers no longer produce paper catalogues that take up space, preferring to produce CD-ROMs. They contain complete data as text or HTML documents. Often, animated graphics are included, showing – for example – the heat transfer and distribution in solar systems in combination with wood pellet boiler units.

10.2.2 Simulation programs from manufacturers

A number of leading manufacturers have begun to make available functionally limited versions of popular timeseries analysis programs (like T*SOL and Polysun) at reduced prices. These then contain only the system components offered by the manufacturer in question; in some cases, they may also contain information on components not typically included in the full versions of the software.

10.3 Internet

10.3.1 Internet portals on the topic of solar energy

There are many internet portals on the topic of solar energy. Information they offer includes:

- Descriptions, explanations and a lexicon of solar energy terms.
- Databases or lists of companies, organizations and other useful addresses.
- Advice for potential purchasers on system sizes, support measures and related materials.
- Event and training calendars.
- News on new products.
- Online shops offering everything from books to components and complete systems.

In addition to 'solar' portals, a number of sites covering renewable energy and energy efficiency are available.

10.3.2 Manufacturer websites

Typically, information about products and services on offer from manufacturers is presented on the websites of the manufacturers in question. Planners and installers can usually find product catalogues, images, product descriptions, presentations, tenders, price lists and wiring/installation diagrams on these sites, either to download and print, or to order on CD-ROM. Information on new legislation and legal matters can also be found, as can articles on technical and market matters. Some offer planning support in password-protected areas.

Increasingly, tips and tricks are also offered, along with access to product support. These sites are easy to find, as the company name is typically part of the Internet address.

10.3.3 Internet-based simulation

Advances in the art of internet programming have made it possible to perform simulations online. Most of these applications have as a primary purpose either adding value to the web site of the service provider, or making it possible for potential clients to predict the required size of their installation. They are generally confined to making suggestions in terms of collector and storage size for predefined and relatively limited cases, or to calculating rough performance values. An example allowing calculation of irradiation, system yield, solar fraction, efficiency and CO₂ savings can be found at www.valentin.de/calculation/thermal/start/en.

11 Marketing and promotion

11.1 The fundamentals of solar marketing

11.1.1 Customer orientation: the central theme

What actually *is* marketing? We like this definition best:

Marketing is the totality of the measures that make it easy for your customer to choose you and your product.

We have divided the subject into three parts: the fundamentals, systematic marketing planning, and the sales discussion – the most direct form of contact with the customer.

Solar energy is an attractive energy. It represents the future and a respectful attitude to the natural and the human environment. In selling a collector you are partly selling this idea. Customer benefit should be the main theme of your marketing strategy.

As the reader you are our customer. What therefore is the benefit of this chapter to you? More enjoyment in sales and acquisition – and more success with less effort. The additional success you will have is shown in the following:

WHAT WILL YOU GET OUT OF SELLING SOLAR SYSTEMS?

You will be:

- Promoting something good (of benefit to the environment and society and of benefit to you as well).
- Advising your customers (your customers' benefit is your benefit).
- Strengthening customer relationships (paving the way for further sales, increasing the level of familiarity).
- Gaining in competence (practice makes perfect, technically and consultatively).
- Improving your image (at the very least showing the customer that you have their welfare at heart).
- Gaining personal satisfaction (emotional self-interest).
- Safeguarding workplaces (safeguarding your own workplace, future opportunities).
- Adding value.

11.1.2 The iceberg principle

Just as you only see one seventh of the volume of an iceberg, similarly only one seventh of our communication is conscious; by far the greater part is invisible (Figure 11.1). However, this part determines the behaviour and the decisions of the person to

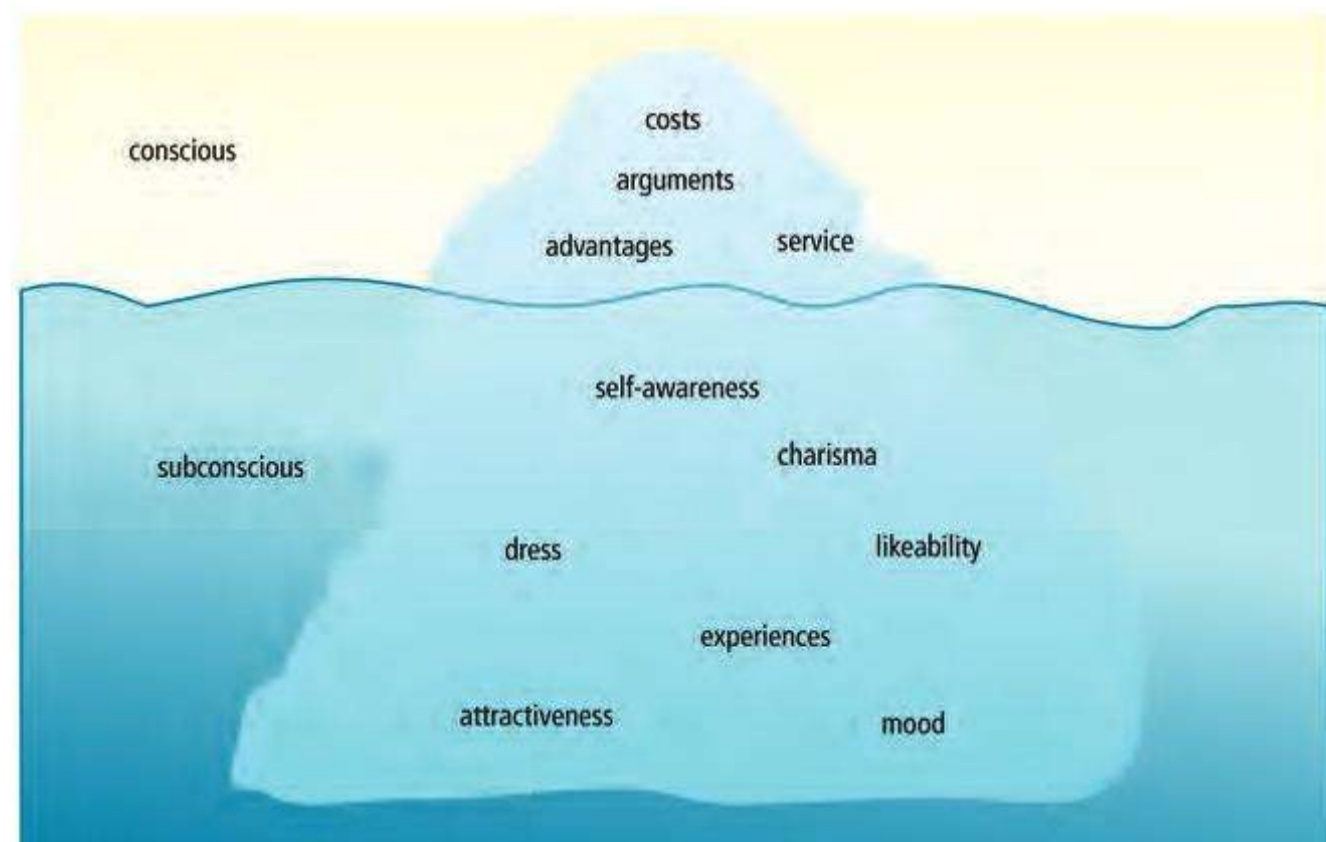

Figure 11.1.
Only one seventh of communication is conscious

whom you are talking. This is true even when trust and a long-term customer relationship with mutual benefit is involved.

This means that, to obtain new business, you must deliberately plan using your common sense. For continuing success, however, your attitude, your feelings and the feelings of your customer are important. It is also important how you dress, and how you behave. You are not only selling a product, you are also selling what you ‘represent’ as a person. Are you credible? Are you good company? Do you have a good rapport with the customers?

The iceberg principle also means that a customer notices very quickly whether you are genuine – for example whether you are really interested in what *they* want. It is therefore worth considering fundamental questions such as: What is the aim of your work? What impression do you want to leave with your customers?

11.1.3 The ‘pull’ concept

He or she who wishes to sell more, first feels a pressure to be rid of something. According to the iceberg principle this pressure is transferred to the customers. They react in the same way that you react to pressure – with resistance! It is much better if you can see yourself as the answer to your customer’s prayers. You read the desires of your customers and can provide all sorts of good products and services for their benefit. In this way you build up a ‘pull’, which attracts the person you are talking to.

Customers will buy something because they are convinced of its benefit. Attitudes and feelings play an especially important role in the pull concept. In addition to the factual information that you provide, they convey an image of your company and your product. You will acquire business if you can portray your product and company so attractively that your customers want to buy exclusively from you.

The most important differences between push and pull are listed in Table 11.1.

Table 11.1.
The difference between push and pull (according to Binder-Kisse⁶²)

Push	Pull
Use every discussion to ‘grab’ potential customers	First build up trust through general discussion, identifying the starting points for cooperation
Aggressive selling	Sale only if the customer really wants something
Sale at any price	Honest, serious advice
One discussion = one completion	Acceptance of a ‘no’
Company image, second priority	Image as significant factor → attractiveness for potential customer
Completion = success factor	Word-of-mouth recommendation
	A recommendation to somebody else is also a success
→ Critical customers, who were forced into buying	→ Satisfied customers, who come by free will
High complaints rate	Fewer complaints
Price sensitivity	Lower price sensitivity

Modern marketing operates according to the pull concept. As the differences between the products of competitors become smaller, so the significance of the relationship between company and customer becomes more important. Marketing therefore does not stop with the sale but sees it as the beginning of a new sale. That may be another product or another customer. What is most important is your behaviour when you create the pull. Is it enjoyable to work with you, to recommend you to others, to purchase something from you? If you make it easy for customers to see the benefits then they will also find their way to you.

11.2 More success through systematic marketing

11.2.1 In the beginning is the benefit

You know and respect your product from a salesman’s point of view. However, each customer sees it from a different point of view. It all depends on perspective! The following shows how important this is:

A novice said to an older monk: ‘I have noticed that you smoke during your prayers. The abbot has forbidden me from smoking during prayers.’ To this the

older man replied: 'It all depends how you approach the abbot: I asked if I could pray while I was smoking.'

The customer is not interested in the fact that a solar thermal system is 6.6 m² (71 ft²) in area and has a selective coating with an emission coefficient of 5%. What he or she wants to know is whether it will supply hot water between April and October. Craftsmen and engineers often concentrate on the technical data as the significant features of their product. Customers, however, are mainly interested in what they will get from it – this is often different for men and women, as it is for private individuals and industrial customers.

Take a look at your products and services and gather together the customer benefits (Table 11.2 shows some examples). Note that there are several benefits to each feature. Identify all the possible benefits from the customer's point of view. The following list of potential benefits will help you in your detective work:

- time saving
- solution to a problem
- cost saving
- environmental protection
- security
- prestige
- enjoyment
- comfort
- health
- information
- entertainment
- public relations (for business customers)
- motivation of staff (for business customers).

Table 11.2.
From features to benefits

Feature	Advantage	Benefit (for customer)
Tempered glass	Resistance to hail	Long service life, no troubles and no repair costs
In-roof installation of collector	Better thermal insulation	Fuel cost savings Visually attractive through harmonic integration into the roof skin
22 m ² collector system	Higher thermal yield	Low fuel costs Noticeable use of the sun even in winter Secure supply in emergencies Reduction in cost risk when energy prices rise
800 l storage tank	Large storage capacity	Hot water reserves in times of high consumption Better utilization of high irradiation Longer bridging of poor weather periods
Storage tank with flow heater principle	Hygiene	Fresh, healthy domestic hot water

11.2.2 The four pillars of the marketing concept

Tie your new business development and sales efforts into a marketing concept. Instead of random calls, cultivate the market systematically. Even two days spent on concentrated planning will save you lots of time, money and stress in the future. You will be able to target your efforts and fill the gaps in your sales cycle; turnover will increase and will continue to do so.

Such a marketing concept is supported by four pillars: analysis of your company, your products, the market and your marketing turnover. In this chapter we are concerned mainly with the last two points. However, it is worth examining the other two areas, and some suggestions in the form of questions are given below.

11.2.2.1 THE COMPANY

WHAT ARE YOUR OWN OBJECTIVES IN YOUR WORK? WHAT IS IMPORTANT TO YOU?

In marketing, your aim should be to acquire orders that serve your own objectives. Your concept of yourself is also important here: for example, do you want to sell as

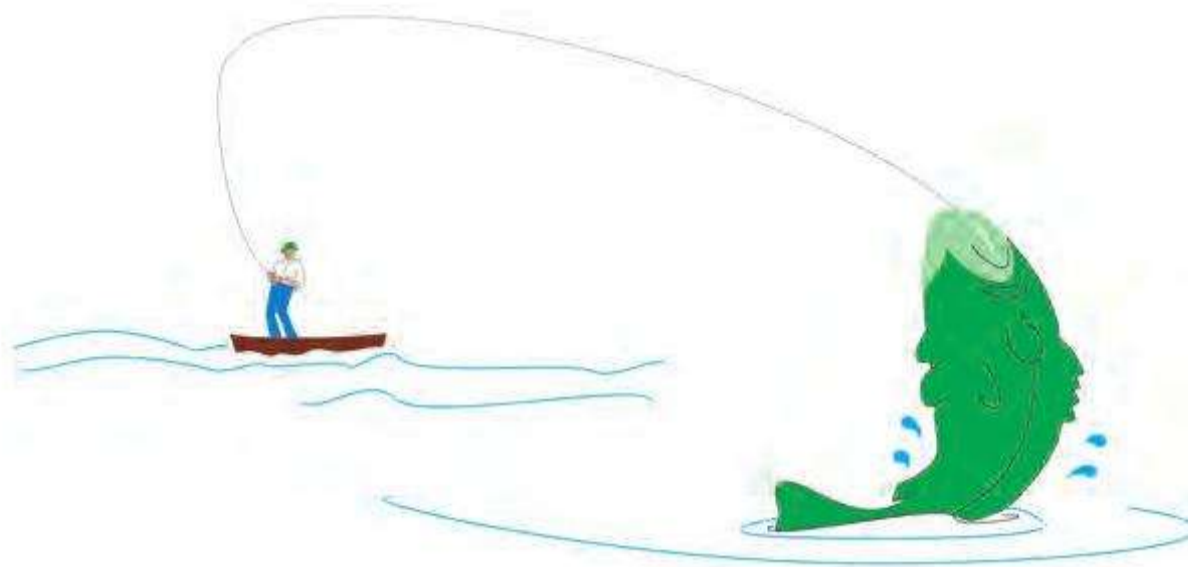

Figure 11.2.
The bait must be tasty for the fish, not
the fisherman!

cheaply as possible, or is quality the most important aspect? How important to you are ecological and social concerns? Are you happy with the external image of your company?

WHAT CAN YOU OR YOUR COMPANY DO PARTICULARLY WELL (STRENGTHS)?

Are you a person who likes fiddly jobs and enjoys designing complicated systems? Or can you handle large-scale standard projects particularly well? The more you concentrate on your core competences the more readily you will be recognizable externally. Customers can then classify you more easily: 'the specialist for heating support from the sun'.

WHAT ARE YOUR OR YOUR COMPANY'S WEAKNESSES?

How does your after-sales service system operate? How long does it take to answer a customer enquiry? Are your most important members of staff – those who are customer-facing – properly trained? You should also consider resources with respect to your marketing. If your efforts were to be successful, could you deal with all the orders and still meet customer expectations?

11.2.2.2 THE PRODUCTS

WHAT ARE THE MOST IMPORTANT BENEFITS THAT YOU OFFER YOUR CUSTOMERS (STRENGTHS)?

This includes both your services (quality, planning services) and equipment (collectors, boilers etc.). Are you up to date? Have you got suitable products for your target group?

WHAT WEAKNESSES DOES YOUR PRODUCT HAVE IN COMPARISON WITH THE COMPETITION?

What reasons do interested parties give for deciding against your offer? What complaints do you get from past customers? Perhaps in the medium term you could include an alternative product in your range, or you could balance, for example, a higher price with extra services such as a free check after one year.

FROM WHICH PRODUCT DO YOU EARN THE MOST? WHAT GIVES YOU THE MOST PLEASURE?

These questions can have consequences for your marketing, your calculations, or the general aims of your company.

11.2.2.3 THE MARKET

WHO ARE YOUR COMPETITORS?

In which area do you work and what are your target groups? What is your reputation, your price structure? How big, how aggressive are you? It is a good idea if now and again you can have exchanges with your competitors, perhaps even carry out common campaigns. If you select your target groups carefully you will generally get on well alongside each other.

WHAT IS SPECIAL ABOUT YOUR OFFER WHICH MARKS IT OUT FROM THE COMPETITION (POSITIONING)?

Formulate this in one or two sentences:

We are specialists for pellet heating with solar involvement. Our firm includes roofers and heating engineers.

You can use this both in printed leaflets and at exhibitions in order to introduce yourself to interested parties. In this way you will be better remembered. Pay particular attention to your positioning. Price, service, quality – all appear equal in one sense. However, customers may be persuaded to opt for your system if, for example, you have an attractive display that graphically shows the solar gain.

WHO ARE YOUR TARGET GROUPS?

Whose problems can you solve best? Who is most likely to be persuaded by the benefits you are offering? (See Figure 11.3.)

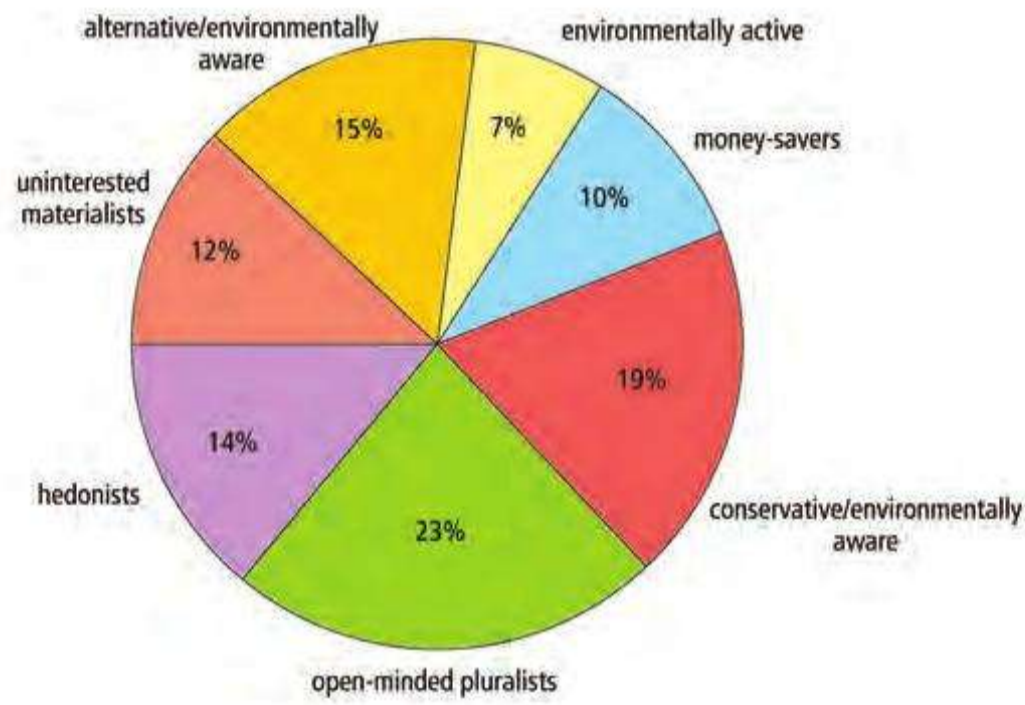

Figure 11.3. Values and consumption patterns of households asked about saving energy. Source: Prose & Wortmann (1991)⁵³

You can develop a separate acquisition strategy for each group. So, for example, alternative/environmentally aware, environmentally active, and conservative/environmentally aware can be targeted with ecological benefits – however, each of the three groups has a different attitude towards life. Correspondingly important are the peripheral elements of your marketing, such as your dress and appearance. This is particularly evident in personal discussions. It is sensible for each person to accurately seek out and talk to his or her target group(s).

MARKETING TIP

Working with schools, you could offer a day of orientation for school leavers. In this way you could ensure new 'solar recruits' and at the same time reach two multiplier groups: pupils and teachers.

With the watering can principle (Figure 11.4) you will never be able to penetrate through the general mass of advertising. It is only with a 'targeted stream' that you can achieve the necessary intensity. And with a targeted stream you can maintain this intensity, as you are only trying to reach a restricted group.

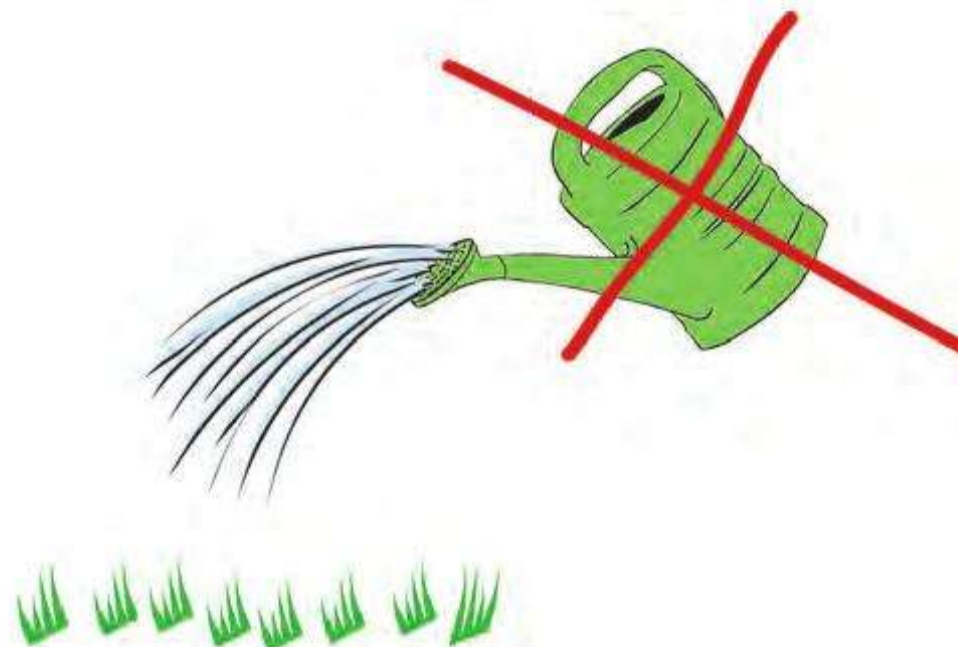

Figure 11.4. Target group derives from target. You won't get rich with the watering can

In your examination of target groups, start with your own experiences. What moves people? Which groups do you feel will be the ones that respond? They may expect that you too should 'take a risk'. Seek opinions from uninvolved people, laypersons, acquaintances; exchange thoughts with your colleagues; survey your customers; read specialist magazines and your local newspaper.

In this way you can keep your ear to the ground and stay aware of what is going on. Perhaps a new building area is being planned, or a solar initiative is being formed in your community.

MARKETING TIP

In a new building development you could make yourself known by direct mail or a mailshot. Those who build do not usually have the money for additional things such as solar systems. You could play along with this and say:

We can offer you non-binding advice as to how you can prepare now for the installation of a solar system at a later date at very little cost.

The threshold for such a customer to make contact with you is thus very low, as there is no need to invest anything at present. He or she will remember you, however, when the need for a solar system eventually arises. And you also offer services other than solar energy; perhaps the customer is unsatisfied with a sanitary installer, and if you are already known...

11.2.2.4 MARKETING TURNOVER

WHO DOES THE MARKETING IN YOUR COMPANY?

The best answer to this is – everybody! From the telephone operators to the customer service technicians, all employees should know how they can contribute to gaining and keeping customers. Are the external sales staff motivated? Is there a training need?

WHAT MARKETING RESOURCES DO YOU HAVE?

These resources extend from printed matter, brochures and sample letters up to standardized procedures. How do I carry out a complaints discussion? How do I behave on the telephone? How is an enquiry dealt with?

WHAT SORT OF MARKETING EXPERIENCES HAVE YOU HAD TO DATE?

Evaluate this in terms of time, money and enjoyment on the one hand and success on the other. Have there been unexpected effects that you can build on and use? What have you not tried yet?

Don't be satisfied with easy answers. If, for example, you were not satisfied with the results from an exhibition, ask yourself: 'Was this due to the exhibition itself or was this my fault?' Are there other exhibitions through which you could reach your target audience better? How can you prepare better? Did you do everything possible to interest the target group?

STRATEGIC CONSIDERATIONS: THE 7C STRATEGY

Before you study the range of marketing tools in more detail, we would like to introduce you to the 7C strategy (C = contacts). This is the basis for the targeted selection of marketing tools. The selection creates a marketing concept out of random marketing.

Figure 11.5 shows the phases involved in winning customers. Without regular reminders, customers will forget who you are – conduct regular campaigns to create interest and refresh their memories! This 'pre-sales' phase requires mental staying power; as soon as you detect some interest it becomes easier.

As a rule of thumb you need seven contacts to gain each new customer. This can extend over years. Do not be put off; the first contact hardly ever leads to success.

In the next section important marketing tools will be introduced. On the one hand the selection of an advertising medium depends on the target group and the message, but it also depends on the advertising budget. Be aware of the difference between fixed costs (for advertising) and variable costs (for example postage costs for mailshots), but also be aware that production costs can vary enormously. For example,

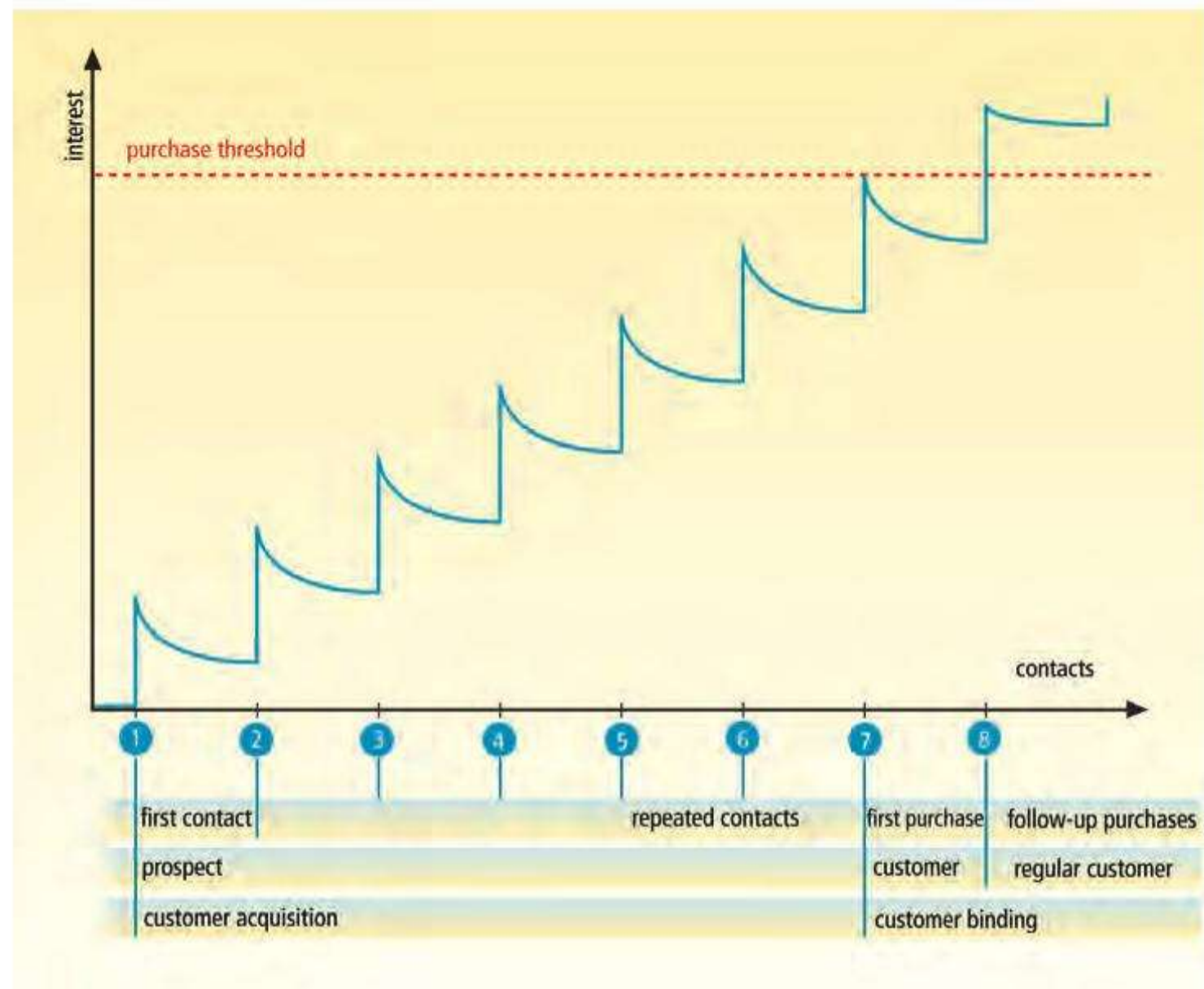

Figure 11.5. The phases of winning customers according to Wittbrodt⁶⁴

the production of printed advertising material is only a fraction of the total production cost for television advertising.

THE COVERAGE OF MARKETING

This list is ordered according to coverage achieved. At the same time, as you move down the list, the mode of address changes from the direct (personal) to the indirect (for example displays), and the absolute costs (not the cost per contact) increase.

- personal contact
- telephone
- event
- mailshot
- newspaper, TV, radio .

Rule of thumb: The smaller the target group the more direct the approach.

11.2.3 The range of marketing options

11.2.3.1 DIRECT MARKETING

PERSONAL CONTACT

The iceberg principle (section 11.1.2) becomes evident with personal contact. Here you can use your personality to build confidence and create a personal bond. Personal contact is mostly used to convey comprehensive advice to interested parties, and is the preparation for final agreement in a sales discussion. It is dealt with in detail in section 11.4.

TELEPHONE

The telephone is an intensive form of personal contact in which all components of the iceberg play a part. With the telephone you create a personal closeness to the customer. You can hear the ‘undertones’. How genuine is the interest? Is it an anxious customer who needs security? Or is the customer well informed, and just in need of clear facts? The telephone is ideal for helping hesitant interested parties over the contact threshold to the next stage.

As a rule, with the telephone you can pick up early expressions of interest which you can then supplement with a mailshot. Telephoning is an art that you and your staff can learn. Section 11.4 provides some suggestions; it is worthwhile pursuing this theme more intensively

MAILSHOTS

Mailshots are the most commonly used marketing tool, which is why they are given more space here. They are a good compromise between the direct and indirect approaches, and stay within reasonable financial boundaries. You can use mailshots for various purposes:

- to create interest – for example to create an initial contact
- to update wide target groups (offers, events, new products), for example within the scope of the 7C strategy (see section 11.2.2.4)
- as regular reminders in order to build customer relationships.

In general mailshots should trigger a reaction and the customer should then make contact with you.

THREE FINDINGS ABOUT MAILSHOTS

1. It becomes more and more difficult to get the required attention. Even response rates of 1–2% are comparatively good.
 2. A mailshot without a follow-up telephone call makes little sense.
 3. From 1. and 2. it follows that you should go to a lot of effort and use all your creative powers when creating and organizing a mailshot. It is better not to do a mailshot than to do a bad one!
-

DESIGN OF THE MAILSHOT

Have you heard of **AIDA**? This is what your mailshot should trigger in the customer:

- A Attention
- I Interest
- D Desire
- A Action

Attention

The first objective of a mailshot is that it should not be thrown away! This is the hardest part in the composition of a mailshot. Concentrate all your creativity on this. Here are some ideas:

- *Exciting title.* Create a vision in the mind of the reader. You could introduce a product in the form of a headline such as ‘Hot Winter 2003’, or you could announce an energy-saving week with a ‘Squirrel Campaign’.
- *Elegance.* The design will shape the reader’s first impression. Take time to arrange your text and any pictures so that they are pleasing to the eye. (See Figure 11.6.)
- *Picture.* If your product is visually interesting, use a good picture to catch the reader’s eye and to help them remember it.
- *Gimmick – something playful.* An unusual method of folding, punched envelopes, a gift, a folded paper sundial – these all increase the chance that the letter will not be immediately thrown away; however, the cost also increases. Product and gimmick must always be balanced. The content of your message must stand up to the expectations raised by the gimmick.

Interest

This means:

- understanding
- recognizing the benefits.

Put yourself into the shoes of your target group. Which benefits are they interested in? How can you put this across so that it is easily understood? Brevity is the soul of wit.



Figure 11.6.
Typical eye progression when reading a text. In general it is true that: we look in the same way that we read – from left to right; central elements are perceived with particular intensity; pictures are registered before text. Therefore clarifying text should come after the picture or to the right of it; otherwise the reading process stalls

A mailshot should be no more than one page. And it is not just the complete text that benefits from being brief – keep sentences and words concise and powerful. The optimum amount of text for someone to view is 12 syllables. Text that is important for the readers' understanding of your message should not be any longer.

Desire

In order for recognized benefits to be translated into desire, the customer must believe you. The less pressure you put on the reader the better your chance. You should therefore be restrained in your design. In a time when everything flashes and glitters, and mega and giga bargains are to be had, a more solid, self-aware modesty goes down very well.

Action

Your reader should now do something. Make this as easy as possible for him or her, for example by:

- *Tempo*. Have even shorter sentences at the end than at the beginning.
- *Concrete appeal* – what should be done now. 'Reply to this e-mail'; 'Register by 3 July'.
- *Testimonials*. Let satisfied customers say good things about your product. In this way third parties confirm your statements, which lowers the resistance threshold.
- *Gift*. If the cost is reasonable you could offer a gift: 'Wide-awake people who respond before 10 August will receive a solar alarm clock from us.' An early-booker discount is also a gift.
- *Preprinted reply*. A fax/e-mail/web form is standard these days. Just fill in the sender's details. It is often sufficient just to send back your mailshot. You will know from whom it comes by the personalized address.

CHECKLIST

If you think your draft mailshot is good, give it to someone who is not involved and ask him or her:

- Does the design appeal to you?
- Is the subject of the mailshot clear within five seconds?
- Have I formulated it clearly and positively?
- Does it have the desired effect on you?
- Is the message credible?
- How would you react to it?

Organization of the mailshot

Your well-formulated and well-designed mailshot will be put to best use through exceptional organization. Here are some tips:

- Who will phone to follow up the mailshot and when? You should give the recipient from one week to 10 days.
- How do you ensure that each customer has to deal with only one employee?
- How is customer interest logged?
- What happens if they are interested? The customer should get a reply from you within two days.
- Would you be able to deal with the orders if interest is very high? You may decide to send off the mailshot in stages.

MARKETING TIP

Use a current event for your mailshot that will have some personal meaning for the recipient. This enables you to build a bridge and create attention. Events can be anything from the weather to new laws, for example energy-saving regulations or a building restoration programme.

Brochures, sales documents

You need printed information for marketing. As the basis for this we recommend a leaflet that gives information about your company – a flyer. This should be professionally designed and printed. It is like a particularly attractive business card; it is a memory aid that you can give, for example, to interested parties on an exhibition stand.

In each case it is necessary to decide how much information is required (see Figure 11.7). You don't need an expensive, four-colour brochure for every purpose. What is important is that you have current information to hand for the most frequently asked questions. This can be information that you have put together in house, for example reference systems with a photo. A uniform appearance is worthwhile for those who require more information.



Figure 11.7.
The publication pyramid. The further down the pyramid you go, the more simply the information can be configured

11.2.3.2 EVENTS

Events have a particular attraction. You make contact with lots of people over a short period of time. Preparation for and execution of an event is a motivating experience for the whole company. In addition, you may be able to get free coverage in the local press. However, events also take a great deal of preparation and require intensive personnel involvement. During an exhibition it is often only possible to continue with normal business in a limited way. In addition to the costs therefore, you may also have a lower revenue.

Some ideas for events:

- participation in exhibitions and trade fairs
- in-house exhibitions, open days
- participation in local campaigns or events
- product presentations, for example in a hotel
- customer seminars
- presentations.

Events are a tremendous opportunity to obtain addresses of interested parties. Don't take all your informational material with you – instead, offer to send information to anyone interested and in this way you will build up contact addresses. You will also prevent your expensive brochures from becoming yet more waste paper at exhibitions.

MARKETING TIP

Try thinking indirectly: for example, invite a local school class to a solar morning. You will not only enjoy passing on information, but will also gain 20–30 assistant sales staff – no one influences adults as well as children influence their parents!

11.2.3.3 PUBLIC MEDIA

If you want to reach a lot of people you have to use public media. Some examples are:

- the Internet
- press
- cinema
- radio
- television.

Today the Internet is more or less taken for granted. A complete section is devoted to it in this chapter (section 11.2.3.4).

With the press there are many options:

- advertisements
- inserts
- press information
- editorial coverage (a journalist writes about a subject that you have proposed).

Even smaller companies can make good use of the press, at least in the local area. Editors are always interested in new things: if you have installed a solar system on an eye-catching house or if a school class has created and installed a system with your help, then call the local press.

Sometimes a good picture is also sufficient to give you coverage: for example a mobile crane with a large system on its hook, or a system that is particularly architecturally attractive. Ask the journalists what interests them. Give them background information that is of general interest to them. Keep PR and advertising well apart. If you want pure advertising then go straight to the advertising department.

11.2.3.4 THE HOMEPAGE FOR SMALL BUSINESSES*

As a contact and presentation medium the Internet has great significance for marketing. Virtually all large and many small companies have an on-line presence. The following sections show why this is a worthwhile venture, and how resources can be optimally used to set up the Internet presence.

THE AIM OF A COMPANY WEBSITE

According to a corny joke on the Internet, company websites are created either for the boss, the designer or the customers. The aim of a commercial website must always be to gain customers and strengthen customer relationships. Internet sites that are created for pure vanity are therefore not a subject of this contribution. The practical use of a company website is to increase sales, either because the Internet site leads to and accompanies company development, or because it acts directly as a platform for the sale of goods. In the solar area the latter goal is still not easily realized and therefore requires special efforts, which we shall discuss at the end of this section.

CONTENTS OF A SMALL COMPANY WEBSITE

Websites should be of practical use to the customer. Content should be determined by the three W's rule: Who? What? Where? The following questions have to be answered:

- Who is being presented on the website?

* Author: Dr Eduard Heindl, Heindl Internet AG, eduard@heindl.de

- What can I obtain from this company?
- Where do I find the company in the real world?

To enable the customer to easily relate to the Internet site, the complete company name and logo, and the location at which the company operates must be on every page. A search engine will not normally recognise the geographical location in which the company running the website is located. However, customers will be interested in finding a company in a particular area.

Detailed information about the company and the products should be presented on separate pages. A fundamental rule applies to the presentation of information, independently of the respective products; these pages may well be somewhat more extensive than the homepage as the visitor expects precise information on the Internet.

Text should be made more appealing by use of meaningful pictures and graphics. The interested visitor also expects to be able to print out these pages, so they should be configured in such a way that no important information is lost when they are printed.

Company sites should include an accurate description of how to reach the company. This should include a description of the route in text form, and also a map. It must always be easy to print this page.

CONTACT BY E-MAIL AND SPECIAL FORMS

The Internet is the only advertising medium that permits direct contact without a change of media – an opportunity not to be neglected. A contact form must therefore be included on every website, which the customer can easily fill in and then transmit directly to the company by e-mail.

Some simple rules apply to the design of a form. The user should have to fill in as few fields as possible, normally it is sufficient to just have the name and e-mail address or telephone number. It is also sensible to include a free text field, so that the customer can also place a special enquiry. A ‘call-back’ field is a nice gesture, and tells potential customers that you are prepared to cover the telephone costs. What is essential for the effectiveness of on-line forms is that enquiries are processed quickly. It is worth doing this as the user already has a real interest in the company’s services. Users generally expect a reaction on the same day or at the latest on the next working day. To succeed in this the company must clearly establish who reads and who responds to e-mails. Arrangements to cover holidays are essential, as a reply after several weeks is useless. As an alternative, the e-mail address of the company should also be published so that a customer can email the company. This also means that the customer can send photos, for example, at the same time



Figure 11.8. The homepage should look inviting and immediately impart the most important information
Source: www.absak.com

MEASURING SUCCESS

Another special aspect of the Internet is the possibility of determining the number of visitors to the website at little expense. Almost all providers offer a web statistics function for this purpose. The important characteristic variables here are the number of pages called up and the number of visitors. Other variables, such as hits and data transfer, are meaningful to computer professionals but are normally otherwise of little interest. A good website should have at least one visitor per day, otherwise the cost of appearing on the web is not justifiable.

The success of a website, however, is measured not only by the number of visitors, but also by the number of enquiries and finally the increase in sales. This variable is very difficult to establish, as an on-line sale rarely takes place; however, the purchasing support often takes place via the Internet.

A simple calculation should make this clear. For an economically justifiable website the extra revenue should be greater than the cost of setting up and running the site. The costs of an Internet website are made up as follows:

$$C = S + L \times O$$

where C is the cost of the website over the amortization period, S is the set-up cost (one-off), O is the operating costs per annum, and L is the length of time on the Internet until the next major revision (amortization period).

The Internet can lead to new customers, who bring additional net revenue and possibly additional profit:

$$P = L \times A \times T \times M$$

where P is the additional profit, A is the additional customers per annum gained via the Internet, T is the average turnover per new customer per year, and M is the profit margin.

For example, the following values could apply to a larger business:

New customers, $A = 5$

Average turnover, $T = \text{€}5000/\text{\$}5000/\text{£}3500$ per annum per new customer

Profit margin, $M = 10\%$

Cost of setting up Internet site, $S = \text{€}2500/\text{\$}2500/\text{£}1750$

Operating costs per annum, $O = \text{€}800/\text{\$}800/\text{£}560$

Amortization period, $L = 3$ years

In euros:

$$C = S + L \times O = \text{€}2500 + 3a \times \text{€}800/a = \text{€}4900$$

$$P = L \times A \times T \times M = 3a \times 5 \times \text{€}5000/a \times 0.1 = \text{€}7500$$

In US dollars:

$$C = S + L \times O = \text{\$}2500 + 3a \times \text{\$}800/a = \text{\$}4900$$

$$P = L \times A \times T \times M = 3a \times 5 \times \text{\$}5000/a \times 0.1 = \text{\$}7500$$

In pounds sterling:

$$C = S + L \times O = \text{£}1750 + 3a \times \text{£}560/a = \text{£}3430$$

$$P = L \times A \times T \times M = 3a \times 5 \times \text{£}3500/a \times 0.1 = \text{£}5250$$

The additional profit is given by

$$P - C = \text{€}2600/\text{\$}2600/\text{£}1820$$

This means that an Internet appearance that costs about $\text{€}2500/\text{\$}2500/\text{£}1750$ with annual running costs of about $\text{€}800/\text{\$}800/\text{£}560$ is worthwhile in this case, as over three years it generates additional profit of $\text{€}2600/\text{\$}2600/\text{£}1820$.

COST OF IMPLEMENTATION

The costs of an Internet website are made up of four cost factors:

- web design
- web server
- web directory
- Internet access.

Certain key values should therefore be used for the calculation, which naturally depend significantly on the individual wishes.

The web design should always be done by a professional agency, otherwise it cannot be guaranteed that operation of the pages will be technically trouble-free. A professional company can also advise on legal issues concerning the information displayed. Pages that do not function are effectively anti-advertising! A well-designed site with ten pages and a contact form will cost in the order of €2500/\$2500/£1750 (depending on country and level of sophistication).

The web server is not set up in the company but at a provider. A simple site does not require a high-performance server, and thus the costs are around €300/\$300/£210 per annum. A website must also be promoted within the Internet: the best way is to enter it in websites with specific themes and high visitor numbers. The Internet agency must also ensure that the site is easily found by search engines. Another €500/\$500/£350 must be allowed for this each year. Your own Internet access, necessary in order to be able to answer e-mails, does not have to be calculated separately, as it will be mostly used for other purposes, and the cost is negligible in comparison to other items.

SERVICING COST

Those who take Internet marketing seriously and wish to gain more than a handful of new customers each year must also service their Internet site. Servicing mainly consists of updating the contents without visual changes.

Updating means 'moderate but regular changes'. It cannot be said often enough that it is only continuous servicing of the content that leads to noticeable advertising success. No customer expects daily news from a workshop, and certainly not 'current' offers for Christmas or Easter. In most cases three to four hours per month are sufficient to add information such as completed projects to the reference list, to announce appointments, and to delete old information. This work can be done with inexpensive editing systems, which permit web pages to be changed without knowledge of HTML and without endangering the layout.

ACTIVE ADVERTISING ON THE INTERNET

Advertising on the Internet differs from classical print media because the potential customer first has to be made aware of your homepage. There are several ways of doing this, the best of which is offered by the Internet itself and which is described here.

Search engines

Anyone who has used the Internet to solve a problem goes first to a search engine such as Google and enters a keyword or keywords. Out of the first ten results a suitable site is visited, and if the site is good this can already be the start of a business relationship. It is therefore very important that your company appears high up the list. Internet sites should be optimized for search engines. For this to be successful the businessman must know by which search words he wishes to be found. There should also always be a regional reference, in which the place name appears on the Internet site. The site should then be submitted once to the search engines; repeated submission is unnecessary.

Portals

In the traditional media market, specialist magazines provide a service by attracting and retaining a target public. On the Internet this is done by subject-orientated

portals. These have very high visitor numbers, which an individual company could rarely reach. It therefore makes sense for a company to draw attention to their own homepage within a portal. This can be done by placing an entry in a classified directory or by means of banner advertising and links.

Classified directory

There are now a huge number of classified directories ('yellow pages') on the Internet (Google found 114,000), but only very few in which it is worthwhile being entered. A good reference number demonstrating the significance of a classified directory is the number of visitors to the directory per annum.

Banner advertising

The most established form of advertising on the Internet is banner advertising. With banners it is possible to attract the attention of a wide public to a company and to entice new visitors to your own website. A banner is a small picture integrated into another website (see Figure 11.9). This picture is linked to your own site by a hyperlink. The visual configuration of the banner should be restricted to what is most essential. A 468 × 60 pixel area offers little space for text. For a banner to work it is therefore sensible to commission an agency for the graphical work. Banner advertising has the greatest effect when the target public is searching for related products and services. Therefore solar companies should place their banner on websites to do with building, heating, solar energy and environment, as potential customers can be gained there.

The price for banner advertising is usually calculated according to the number of hits and the banner size. According to the situation, between €10 and €50 (\$10–50, £7–35) is charged per 1000 PV (page views).

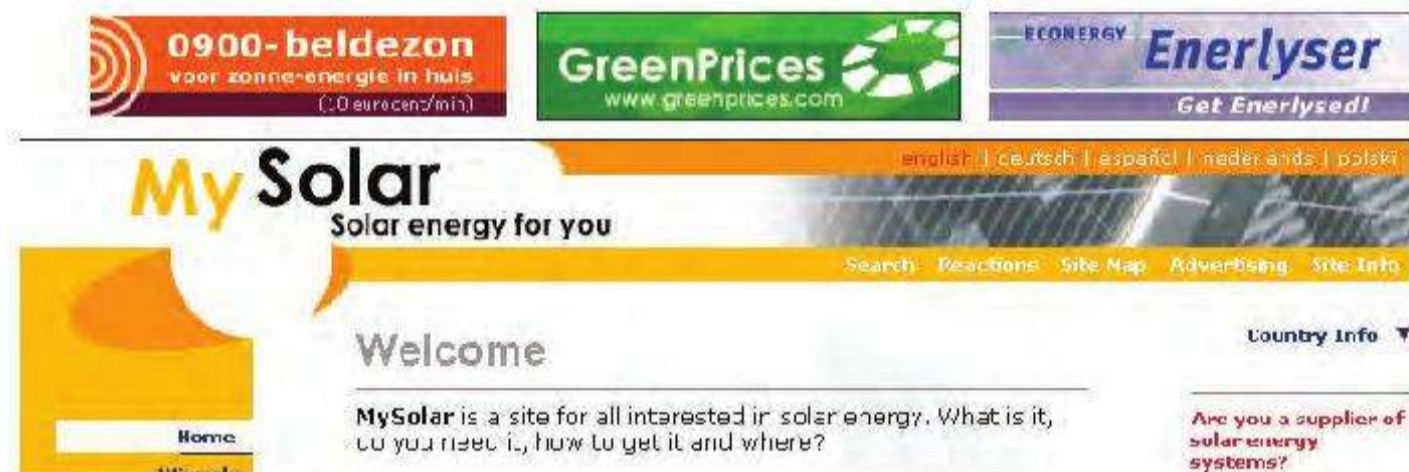

Figure 11.9.
Banner advertising should be placed
where the potential customer surfs.
Source: www.mysolar.com

Links

A website should always be well linked within the Internet. Apart from the options of the classified directory and banner advertising already described, you should try to be mentioned on suppliers' pages with a link. Satisfied customers may also be prepared to have a link from their homepage to yours. In return, you should also be ready to include a link back from your own pages to the respective company.

DIRECT SALES THROUGH THE INTERNET

The Internet is not just a large shop window, it is also developing more and more into a marketplace. However, changes in purchasing behaviour are much slower than the acceptance of the new medium. The opportunities that are now on offer will be introduced here.

Suitable products

Not all products are equally suitable for selling over the Internet. On the one hand the product must be in a price class that represents a justifiable risk in dispatch and payment. On the other hand the product should be capable of being used without further support from the vendor. This is not the case for solar thermal and photovoltaic systems today; however, many other products in the photovoltaic area are well suited to the mail order business. In a sales analysis by Solarserverstores (www.solarserver.org) an optimum price of about €100/\$100/£70 was established. Items that sell particularly well on the Internet are charging units and solar lamps, as well as solar-operated household articles and solar watches.

Click the 'info'-button if you need more information about this step

Step 5: Your Solar

US32

Supplier: Solar Electric Inc. **San Diego**

Specifications:

Manufacturer/producer:	UNI-SOLAR
Price excl. (Dutch) subsidies:	\$ 159
Warranty period:	Year(s)
Installation manual:	Yes
Do-it-yourself article:	No
Service contract:	No
Comments:	Inverter as per customer requirement and in addition to the cost described here
Power [W _p]:	32
Costs [\$/W _p]:	\$ 4.97
Roof Surface [m ²]:	0.52

Figure 11.10. Direct sales on the Internet can be completed with shop systems. The product prices must be accurately calculated.
Source: www.mysolar.com

Technical costs

An on-line shop requires very high investment, both for the software and the product entries as well as for the day-to-day operation. Today standardized program packages, the installation and operation of which require considerable experience, usually serve as shop software. This software must run on a powerful and very reliable computer, otherwise a high number of hits may cause delays or frequent server failures. It is therefore recommended that an experienced service provider, who can demonstrate comparable projects as reference, should carry out the implementation. The cost for technology and software in the first three years is at least €10,000/ \$10,000/£7,000. On top of this there is a cost of about €50/\$50/£35 for each product entered in the catalogue.

11.2.3.5 CUSTOMER RELATIONSHIPS

So far we have only discussed the winning of new customers. But what do you do with the customers that you have already gained? For most companies a large treasure chest remains buried in this area. It is seven times easier to reactivate an old customer than to gain a new one. Therefore customer focus as a theme is not only more enjoyable but is also the more successful approach.

Consistent customer focus in all customer relationships (Figure 11.11) is a culture in which the management must set an example and which they must also implement in all areas of the company. The installer should know exactly what was promised to the customer when the contract was awarded. Apart from neat craftsmanship he must also feel that he is responsible for cleanliness when working in the customer's house. He should also be aware how to professionally handle a special wish or a complaint by the customer. Some can do this naturally, but as a rule training is required.

MARKETING TIPS

- Carry out a mailshot campaign to your customers. Use a questionnaire to find out about customer satisfaction and offer a small gift for returning it.
- Variant: Ask for details of acquaintances who may be interested in solar systems and offer a gift for every address.
- Alternative: Send a questionnaire with the invoice, which can be returned anonymously.

Satisfied customers help you to sell. Ask whether they would be willing to give a reference. If they agree, show your appreciation. The opportunity to ask existing customers about their experiences is worth much more to a potential customer than anything you can promise. The offer alone strengthens credibility. At the same time you are displaying customer care: the existing customer feels honoured and will probably also enjoy passing on his or her knowledge.

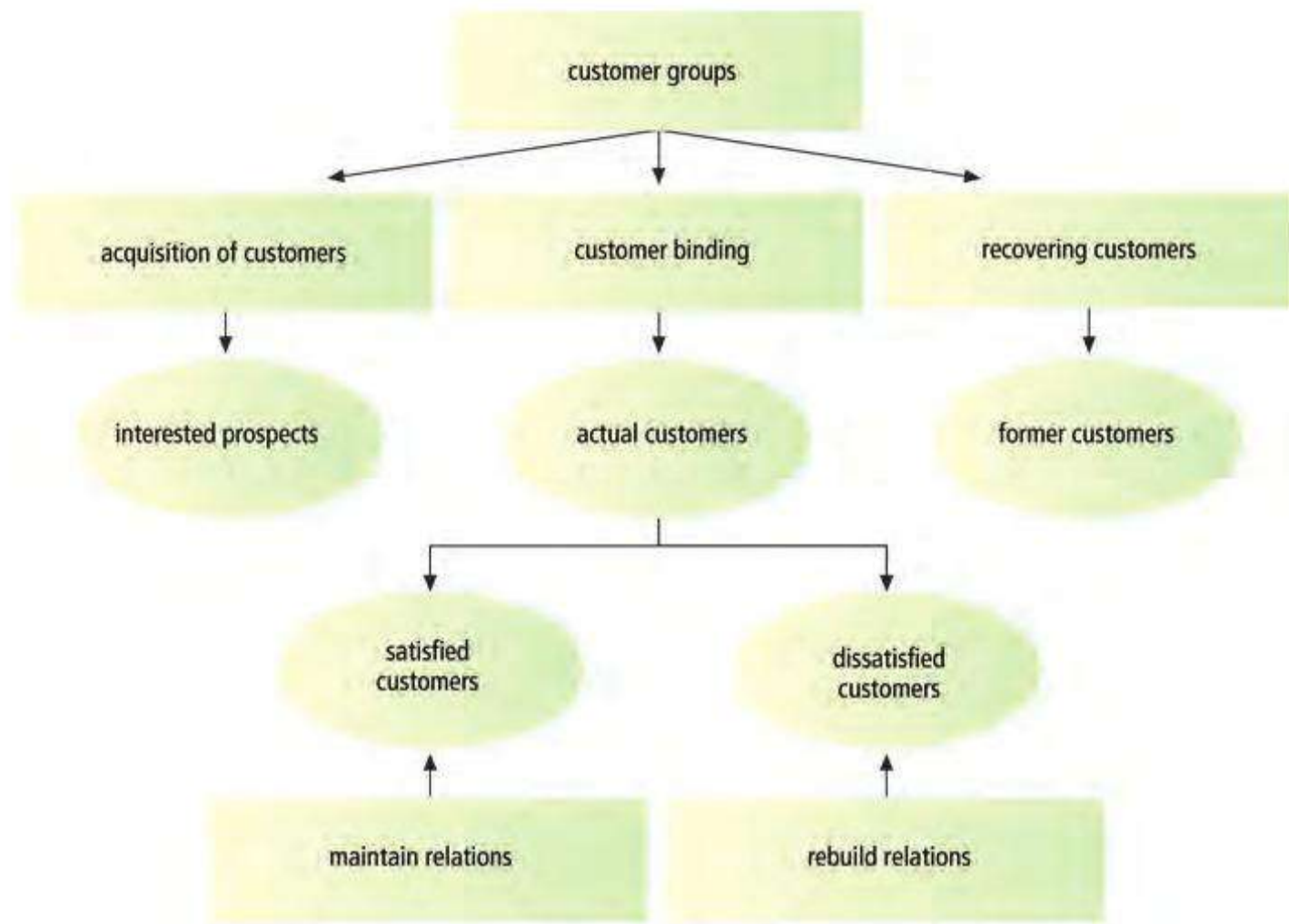

Figure 11.11. Customer relationships (according to Binder-Kisse⁶²)

11.2.4 To the goal in six steps

11.2.4.1 THE BASIC IDEA

To acquire customers for solar energy you need great staying power. So that you don't exhaust yourself, we recommend a systematic procedure in six steps: the *marketing cycle* (see Figure 11.12). For large campaigns it is best to work through this cycle twice. Start with a test run and just a few addressees. With the experience gained from this you can then improve the main campaign.

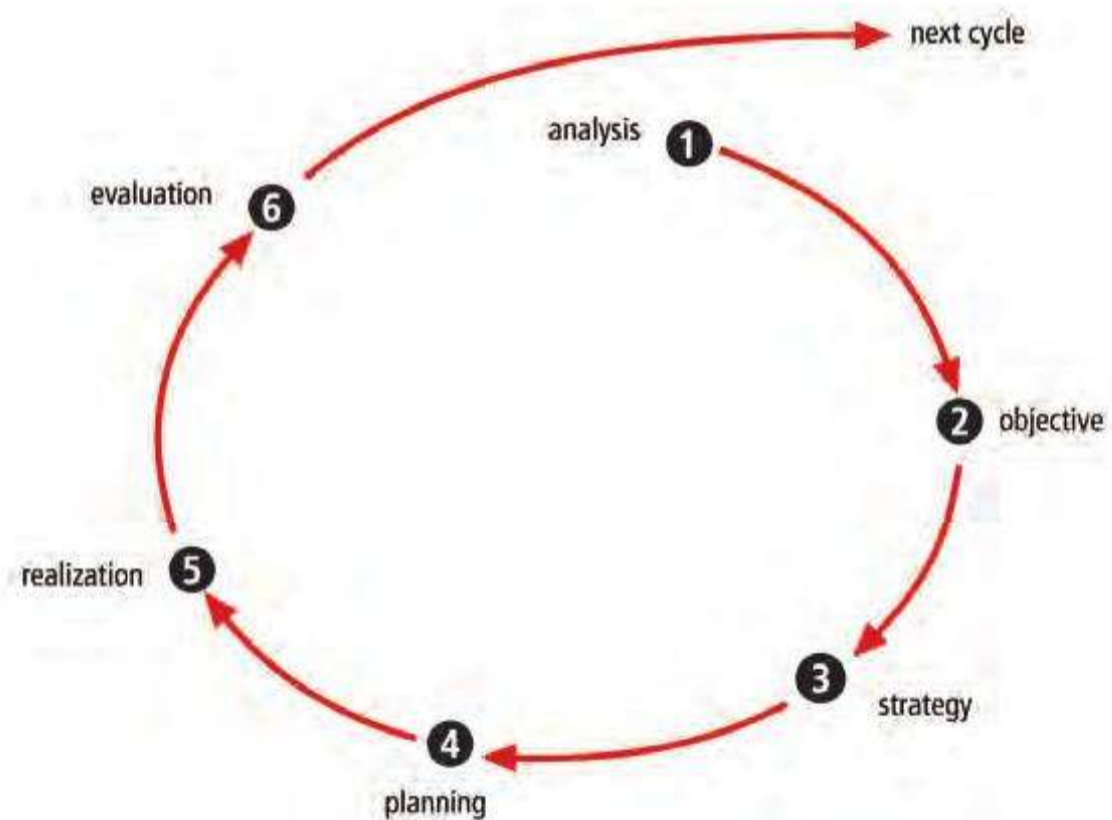

Figure 11.12. Marketing cycle in six steps: analysis; objective; strategy; planning; realization; evaluation

You may think you don't have time for all this. However, you need to find the time! Systematic marketing will ultimately take less time than random calls which don't produce the desired result.

For example, block out half a day each month for planning your marketing efforts. In addition, at a quiet time – such as between Christmas and New Year – take two days to consider the marketing concept for the next year. Of course, you will also need time for implementation, whether that is attendance at a trade fair or a mailshot. If you have planned well you can distribute the work for these campaigns over several shoulders. When everyone works on a joint campaign for a few days it strengthens the sense of belonging to the company. And the success of a well-planned campaign spurs everyone on!

In the following, the six steps of the marketing cycle are discussed both theoretically and in an example – a marketing concept by the company Heating and Sanitary.

11.2.4.2 STEP 1: ANALYSIS

You can find information on this in section 11.2.2. In addition you should:

- evaluate your previous marketing activities in terms of cost and benefit
- evaluate your business situation
- keep your eye on the future development of the company.

Company boss Mr Heating has found from discussions with competitors and association officials that he is profiting less from the solar boom than his competitors. His wife and sons, as well as a glance at the balance sheet, show him that he has done little in the area of marketing. His customers previously came to him if they wanted a new bath or had a broken heater. Mr Heating Senior recognizes that this is no longer sufficient.

11.2.4.3 STEP 2: OBJECTIVES

Objectives make it possible to set and specifically select priorities. They make it easier for you to retain an overview, even in hectic situations. Objectives free up additional energy, because they activate your subconscious and support you in concentrating on the essentials.

So that this isn't merely a declaration of intent, you must really work through your objectives. Write down the results, and make them 'SMART':

- Specific: what exactly?
- Measurable: how do you check your success?
- Achievable: can it be done?
- Relevant: is the result important to the business?
- Time plan: by when do you want to have achieved it?

What do you think of the following objective: 'Next year I want to have more time for the family'? Exactly – too vague. It is better to say: 'From 1 March I am going home at 5 p.m. on Tuesdays and Thursdays'.

Among other things Mr Heating Senior plans to do the following in the first days of the new year:

- By 9 January I shall prepare a marketing strategy for the current year.
- This year I shall actively gain 20 new customers for solar systems.

11.2.4.4 STEP 3: STRATEGY

Prepare a 7C strategy for your target group(s) (see section 11.2.2.4) and translate this into a rough time plan. In this you should mark the marketing activities month by month. Enter fixed dates such as trade fairs and holidays.

A few tips for this:

- As a general rule plan four to seven contacts per customer each year.
- Don't overload the contacts. Include some information but not a whole package.
- Change the medium. For example, use a Christmas greeting.
- The form of contact is not as relevant as its permanence.

Consider when the more favourable and less favourable times are. You must therefore consider the following dates in particular:

- mailshots: holiday dates, Christmas/New Year period
- telephone marketing: holiday dates, office hours
- daily rhythm: lunch breaks, meetings, Friday afternoon
- events: public holidays, trade fairs, parallel events, weather.

Reserve half a day in every month for updating your 7C strategy.

11.2.4.5 STEP 4: PLANNING

To obtain new business you are concerned mainly with operational planning. As a rule you prepare a marketing plan for one to two years. Do not give up if you don't have immediate success. Obtaining new customers requires persistence and long-term thinking.

The 7C strategy provides the rough timescale. For detailed planning you should set up a schedule of tasks for the individual campaigns (such as a mailshot). In this you must establish:

- Who? (responsibilities)
- What? (definition of tasks)
- By when? (time plan)

Plan the necessary initial and follow-up work, such as:

- Designing the advertising material, for example a circular.
- Obtaining the necessary details about the advertising medium, for example magazine deadlines.
- Gathering addresses (for example, from an address search in your own database).
- Allocate time for your own involvement. You control the campaigns. The success depends upon your availability. Do it in small morsels where possible. You don't have time to call 50 people on one day, but if you make two calls every day you can get through them easily in a month.
- Check availability of the necessary staff. Block out well in advance the time when you will need all the staff involved in the new business to get together. If you don't, no one will have time for it; it will also create a strong feeling of togetherness.
- Schedule follow-up work for those who are most interested. Good organization is worthwhile. You must know who gets what, who your A customers are, and when the next campaign is due. You must also know when to reduce your efforts, or when to reallocate addresses from category 'A' (very promising) to 'C' (less promising).

Mr Heating Senior has drafted the schedule of tasks shown in Figure 11.13 for the initial action in his 7C strategy (producing a flyer).

Who	What	When
Team	Brainstorm on content	10-1-04
Smith	Select marketing agency to take over text, graphics and production	10-1-04
Smith	Establish content and discuss with marketing agency ('briefing')	17-1-04
Jones	Clearance on rights of figures, deliver figures together with logo and other material to marketing agency	24-1-04
Marketing agency	Draft layout and text for proofreading	24-1-04
Smith, Marketing agency	First correction round	7-2-04
Smith, Marketing agency	Second correction round	14-2-04
Jones	Collect addresses for distribution of the flyer	19-2-04
Smith	Determine number of copies and give clearance to print	19-2-04
Smith	Check printed version	29-2-04
Jones	Distribute flyer to external addresses and internally to all colleagues; Secure documentation copies and spare copies; Reserve number of copies for trade fair and other events; Track distribution and signal timely (3 months in advance) when reprint is necessary	3-3-04
Smith	Collect suggestions for improvement in next version	From 29-2-04

Figure 11.13.
Planning for the flyer for Heating and Sanitary

11.2.4.6 STEP 5: REALIZATION

There is not much to say here, except – do it!

The greatest danger of marketing campaigns is that, just when they start, something else much more urgent arises. Stay with your 7C concept! Marketing is important. You as the boss must provide the urgency that it requires.

Mr Heating Senior takes on board this recommendation. He has agreed all the dates well in advance with his staff, and has assigned one person for emergency customer help during the campaign. In this way the remainder of the team can concentrate fully on marketing.

Addresses are of central importance for marketing realization. How do you obtain them?

OBTAINING ADDRESSES

A common source is the telephone or address book. Member or company directories are often helpful. You can very easily collect the addresses of interested parties yourself on the exhibition stand or at an information centre in the town. Make it a rule to obtain the requirements and address of every interested party. Don't overdo the amount of advertising material you take with you; send the selected information to those interested – for this you need the addresses.

You can use the Internet to obtain addresses in two ways:

- *Homepage.* A concise, informative homepage is sufficient; it doesn't have to be graphically sophisticated. What is more important is that the homepage is registered with the search engines; always check that you can be found. On your homepage offer interested parties the option of requesting material.
- *Portals.* A register of the most important portals on your subject. A basic entry is often free, and it is often worthwhile to pay for a link to your own homepage. In the solar area: register with www.top50-solar.de, www.top50solar.nl, www.top50solar-esp.com, www.ises.org, the correct sublistings in www.yahoo.com and similar site listings. In this way you can also see how often you are accessed in comparison with the competition (see also section 11.2.3.4).

There are many service companies that have specialized in the sale of customer addresses. Many address suppliers have concentrated their developments on regions or fields. It is often worthwhile comparing suppliers. Addresses can be searched for according to various criteria.

ADDRESS MANAGEMENT

A well-managed customer database is a valuable resource for a company. Give it the necessary attention. Table 11.3 shows a good general structure of an address sheet.

Table 11.3.
The three areas of an address sheet
according to Binder-Kisse^{F2}

Address data	Name of the company and legal form Address, telephone, fax, e-mail, customer no., field, company size and turnover if possible
Profile data	Name, first name, function, position, extension and mobile telephone no., possible other information: date of birth, hobbies etc.
Action data	Date of initial contact, contact history (meeting minutes), action history, products ordered, ordering media, order value, any reminders and open positions

The following procedures have proved to be worthwhile:

- The addresses should be able to be viewed and changed by all participants. A notebook computer is recommended for external sales staff so that reports can immediately be made after a discussion.
- Notebook and server database must be automatically compared.
- Include a contact history in which you record important discussions.
- Keep a history of actions taken, in which you note all marketing activities. What does the customer already possess in the way of documents? Which invitations or greeting cards has he received?
- Don't just record all the contacts but also all additional information that has been obtained during the acquisition of new business, for example customers' preferences.

- Using 'search terms' mark which product your customer is particularly interested in. In this way it is easier to put together the address lists for mailshots etc.
- Assign your customers into two or three categories. 'A' customers are the ones you must concentrate on; for 'C' customers the interest in your products is weaker.

11.2.4.7 STEP 6: EVALUATION

Immediately after a campaign evaluate the cost and benefit, for example in your monthly marketing planning. At the end of a year it is worthwhile carrying out an annual review. It is only after fundamental evaluation that you can really enjoy the fruits of your work. In this way you can plan the next phase more effectively and efficiently.

At the company of Heating and Sanitary, marketing has been well worthwhile. After one year they have gained 23 new customers with an order volume of around €320,000/\$320,000/£224,000. The cost was significant: €26,000/\$26,000/£18,200, plus 40 person-days from the staff. However, much of the work that was done can still be used during the following year, and the customers were so satisfied that the first contracts were surely not the last.

'Success is going from failure to failure without losing enthusiasm.'

(Sir Winston Churchill).

11.3 The Soltherm Europe Initiative: European network of solar thermal marketing campaigns

In Europe, the Soltherm Europe Initiative is a platform to bring together marketers and promoters in the field of solar thermal energy. The Soltherm Europe Initiative aims to create cooperation between sales and installation companies, and information centres and information campaigns.

The Soltherm Europe Initiative started its activities in the form of an EU Altener project that was initiated in 2002. The following key parties are included in this project:

- Europe: European Solar Thermal Industry Federation, Climate Alliance
- Austria: Arbeitsgemeinschaft Erneuerbare Energie, Ober-TMsterreichische Energiesparverein, Grazer Energie Agentur
- Belgium: 3E
- Denmark: Danish Technology Institute, Ellehauge
- France: Ademe, Rhone-Alpes Energie Environnement
- Germany: Bundesverband Solarindustrie, Berliner Energie Agentur, Door2Energy
- Greece: Centre for Renewable Energy Studies
- Italy: Ambiente Italia
- Netherlands: Ecofys, Novem
- Spain: ICAEN, Trama
- UK: Building Research Establishment.

The project provided a suitable start for the Initiative, but Soltherm Europe has the vision to become a long-lasting and strong action network, supporting market campaign organizers throughout Europe in the coming years.

11.3.1 Publications

At present the structure of the platform is being built up to inform and support new campaigns. The first publications for market developers are already available:

- A European market report together with in-depth market analyses for the ten countries and three regions represented in the project. What market stimulation actions worked in a specific case, why, why not, and under what conditions they would work again.
- Soltherm campaign guidelines that are based on the most striking campaigns throughout Europe and the combined experience within the Soltherm project team. The campaign guidelines contain a number of elaborate example campaign formats,

plus expert information on how and when these should best be used to design new campaigns. Success factors and common bottlenecks are analysed. The experience is condensed into a campaign checklist for organizers of market stimulation initiatives.

- A central Internet site, www.soltherm.org, serves as the central information vehicle, with entries for consumers, industry, installers, campaign organizers and various groups of consumers. The above reports as guidelines are available for download here.
- On the Internet site an expert campaign tools library is available, providing hundreds of tools and information sources, and thus serving as a library for the organizers of campaigns. The material includes campaign handbooks, promotion materials, model contracts, performance calculation tools, picture and photo collections, and much more. Each tool is presented with an expert comment sheet (in English and in the language of the tool) describing who should use the tool, when and how, and where and how to obtain it. The library has search and selection functions in a number of languages so as to be useful for local campaign organizers, installers and other parties.
- The Internet site is planned also to feature products and installers' databases, where both campaign organizers and consumers can find the available products and installers, together with basic information and objective quality indicators (such as local certificates, compliance with the European Standards and the European quality certificate the Solar Keymark).
- On www.soltherm.org an on-line overview of quality standards and certificates for products is available. These provide campaign organizers with clear criteria for distinguishing quality products and installers.

11.3.2 Partnership

The Soltherm Europe Initiative has over 50 partners including government departments, ISES Europe, the IEA, industries, installers and energy agencies, and it is still growing steadily.

News and project opportunities are exchanged within this partnership; it also provides a network that enables Soltherm partners to access each other's experiences and expertise more easily.

11.3.3 Campaigns and market activities

The exchange of experience and the Soltherm Europe partnership are also used to develop new initiatives and enhance existing campaigns. Some examples of such campaigns (at the end of 2003) are as follows:

- In Austria, a Soltherm working group is being set up: two workshops were held, presentations were given at workshops/conferences, and newsletters have been distributed.
- In Belgium, the Soltherm Walloon campaign is continuing, and a communication campaign is in preparation.
- In Denmark, a city campaign was started and a national workshop held. Another workshop is planned.
- In France, the Plan Soleil is continuing with publicity on TV, in national newspapers, brochures, a call centre and other measures. In the Rhône-Alpes region a campaign 'Coup de Soleil' is in preparation, a Soltherm workgroup is discussing an ambitious action plan, and newsletters have been distributed.
- In Germany, a campaign aimed at the housing associations is in progress: three workshops, an Internet platform (www.soltherm.info), a conference, other presentations, a brochure and consultancy.
- In Greece, a national workshop was held discussing barriers to further market penetration and how to overcome these.
- The Italian 'Paese del Sole' initiative is supporting local promoters of solar thermal energy, with the first seven municipalities across the country starting this summer. In March 2003 a workshop was held in Verona.
- In the Netherlands, three solar water heater campaigns were started after a mailing to municipalities. A corporation is offering solar energy systems to its tenants, and has over 250 customers so far. A national workshop is in preparation.
- In the UK, a campaign was held in the East-Cambridgeshire region.

- Cape Town in South Africa finalized a mandate for solar thermal systems on all new buildings.
- Syria has mandated building designs suitable for solar hot water systems.
- New Delhi has mandated solar hot water for a selection of new building types.
- The German state of Baden-Württemberg has enacted a law requiring 20% of water and space heating requirements to come from renewable sources, while existing buildings have a two-year window to reach 10%.
- Norway now requires renewable hot water heating in all public buildings larger than 500 square metres.
- Hawaii now requires solar hot water systems on all new residential building construction from 2010.
- Canada has adopted a 25% investment subsidy on solar hot water systems.
- Luxembourg is now providing subsidies as high as 45% for solar heating.
- Mexico has established a 'Green Mortgage' programme to help finance solar hot water systems.
- Morocco has lowered VAT on solar hot water systems.
- The United States has extended a Federal Tax Credit of 30% on solar hot water through to 2016.

11.3.4 Cooperation

The Soltherm Europe Initiative is also integrating with existing initiatives to obtain maximal synergy. For example:

- integration with and promotion of the ESIF/ASTIG Altener Solar Keymark project: linking this EU quality label to information campaigns will speed up the acceptance of EU quality standards
- cooperation with ISES Europe to combine the knowledge collected in the WIRE facility with the experience of the project parties.
- integration of the Altener Qualisol project, aiming at an improved and broadly disseminated solar installer qualification.
- cooperation with the German BSi, for example on the follow-up of the Solarwaerme Plus campaign.
- cooperation with the French Plan Soleil, managed by Ademe (see above).
- cooperation with the government of the Wallonian parts of Belgium in the framework of their Soltherm programme, in which many elements of the Soltherm Europe Initiative are already incorporated.
- integration of the Altener SOLHAS project aiming at developing a market development approach for housing associations in Europe.
- integration of the Dutch Space for Solar Initiative, a foundation of about 60 housing associations and other organizations that collectively purchase and install collective water heating systems.
- cooperation with the Mediterra Solar Campaign, which is embarking on an action plan to stimulate the market for domestic solar thermal applications in France, Spain and Italy.

The Soltherm Initiative is geared to become a major support structure for European market actions and campaigns, and all organizations that want to participate are invited to join the initiative. More information can be found on www.soltherm.org.

11.4 A good sales discussion can be enjoyable

11.4.1 What does 'successful selling' mean?

A good sale does not mean 'completion at any price'. The focus of attention is customer satisfaction. If you advise them well your customers will recommend you, even if they themselves do not purchase anything else. Customer satisfaction is not everything, however; you also need to feel satisfied, and for example should not invest too much time unnecessarily. Successful selling therefore means striking a good balance between the cost and benefit of the sale.

Purchasing – and therefore also selling – is a matter of trust. This involves mainly honesty and respect. Good salespeople take their customers seriously, even if at first glance their interest seems strange or they give an awkward impression. Most products in one category differ only slightly. *You* as the seller make the difference. That is a demanding task – and one that can be fun, because here you can be creative!

This section offers you tools and a tailor-made conversation guide with which you can sell efficiently: from finding out the need up to conclusion. Your personal style is important, because a salesperson must be authentic; a customer can immediately see through hollow words.

11.4.1.1 PERSONAL REQUIREMENTS

Selling means handling people well. There are two observations to make on this:

- *The unconscious level will assert itself!* Remember the iceberg principle: only one seventh of communication is visible on the surface; the rest is invisible, but still very effective. This is especially shown by your gestures and facial expressions – body language does not lie. Therefore use ‘tricks’ only in a limited way; it is important that they are consistent. Only if you yourself are deeply convinced about yourself and your product, can you convince your customer.



Figure 11.14.
Smiling (even if only internally) is a good sales aid

- *The quickest thing you can change is yourself!* You can't change difficult customers, but you can protect yourself from them by well-managed conversations.

Good salespeople build up a close personal relationship with their customers. They show interest in the customer even beyond the immediate order. They make it easy for the customer to make contact – through friendliness and accessibility. They are of benefit to the customer, and will even tighten up the union nut on a dripping tap while they are checking the pre-requirements for a solar connection in the cellar.

During the sales discussion the central arguments are the benefits. However, for the discussion to be successful the secondary, emotional components are just as important. Arguments without the secondary components are like an apple without its flesh: the core is nourishing but doesn't taste very good.

THE FOUR PHASES OF A SALES DISCUSSION

In the following, the four phases of a typical sales discussion are discussed in more detail:

- Build a bridge.
- Establish need.
- Offer a solution.
- Achieve a result.

These phases can take place at several levels, and may partially be repeated. After the successful completion and installation of a solar system, the task of the salesperson is not complete. He or she remains the customer's partner and should offer customer care, so that the customer will help the salesperson by enthusiastic further recommendation.

11.4.2 Build a bridge

11.4.2.1 INNER ATTITUDE

Here the iceberg comes into play again. If you want to conduct a customer discussion you need to have a positive attitude to your task and to the customer. A good exercise for this is to consider: *What pleases me?* Pause for a moment before a contact. Consider

what will please you in the coming meeting. You can also think about the nice evening you had yesterday, or what plans you have for the weekend. You should also fill yourself with inner sunshine.

11.4.2.2 MAKING CONTACT

Whether it be on the telephone or in a personal discussion, whenever you make contact the person you are talking to needs to know to whom he or she is speaking. Here it is particularly helpful if you can refer to mutual acquaintances or activities. You have surely already noticed how a reserved voice on the telephone relaxes when you name a mutual acquaintance. This is called a *bridge*.

CHECKLIST FOR MAKING CONTACT

Note the name of your contact and use his or her name a number of times when you speak.

Tell your contact:

- who you are, and which company you come from
- why you have made contact.



Figure 11.15.
Build a stable bridge to your customer

Find a positive approach. It is best to find things that relate to the customer, such as:

- 'I recently passed your house and was very struck by it.'*
- 'I know of you from your activities in the horticultural association.'*
- 'I got your address from Mr Green.'*

During the follow-up contact:

- 'How are you?'*
- 'Nice to see you/speak to you on the telephone.'*
- Other options: 'small talk' as a starting point (weather, travel route etc.).

Tell the customer why you are here:

- 'I am interested in finding out what you think about solar energy.'*
- 'We are contacting our customers about solar energy, and would like to hear your opinion on the subject.'*

Do not assume that your discussion partner has the time to speak to you. With one question you can show that you are not going to push too hard, and give him the choice:

- 'Do you have a couple of minutes?'*
- 'How much time have you got?'*

In this phase do not talk about the details of your services. If you make a presentation too soon, the customer will begin to ask questions – particularly questions about the price!

It is now the customer's turn: clarification of need.

11.4.3 Establish need

This is the most important phase of a sales discussion. Here you must identify the needs of the person you are talking to.

11.4.3.1 QUESTIONING TECHNIQUE

If you are able to ask good questions you already have the best prerequisites for leading a good discussion: 'He who asks, leads.' But here too the iceberg principle applies: only if you feel that the other party has a genuine interest will he or she not find your questions too 'pushy'.



Figure 11.16.
With the sharp eyes of a detective you
should establish the needs of your
customer

CLOSED QUESTIONS

Closed questions, to which the only answers are 'yes' or 'no', are the most frequently used form of questioning. Such questions permit you to come to clear agreements:

'Can we meet on Friday?'

'Is the 5th OK for you for the installation of the solar system?'

With semi-closed questions (to which the answer is usually one word or a fact) you can get specific information at the start of a discussion. These can also be called 'W' questions: Who, When, Where?

'How many people live in your house?'

'When will the roof be covered?'

This type of question is ideal to get to the point where your customer has to make a statement. You should ensure that the closed question is always linked to a buying argument, which makes it more difficult for the customer to say 'no':

'Would you like the anodized surrounds so that the collectors match your roof better?'

'Would you like two further modules so that you can fully utilize the subsidy?'

OPEN QUESTIONS

Open questions are designed much more to encourage your contact partner towards consideration. In this way you can tie him or her into the discussion and obtain the maximum information – occasionally also unexpected information. In the heat of the moment you may see this unexpected information as unwelcome because it needs

consideration and flexibility. However, it can also be a real gold mine. It is well worthwhile following it up. Perhaps you won't sell any solar collectors, but instead a water treatment system for the swimming pool.

While you are in the 'Establish need' phase you should ask mainly open questions. In this way you can move a faltering discussion along and open up quiet people:

'How do you see the energy supplies to your home in the medium term?'

'What is of particular value to you?'

'What difficulties did you have in that?'

Throw pebbles!

Imagine you are walking along by a high wall and want to know where on the other side a pond is. How do you find that out? You keep throwing pebbles over the wall – until you hear that you have found it by the splash. Use this detective's intuition to find out important information for yourself.

Rucksack technique

You should always keep your full range with you – in a rucksack, in a manner of speaking. If you are attending to a dripping tap at a customer's house, keep your eyes and ears open for other opportunities of working for the customer. Make it a habit always to glance at the roof and ask every customer, 'You have such a nice south-facing roof; what do you think about solar technology?'

Coffee filter

Let your discussion partner finish talking. Give him or her time to formulate complex thoughts or to become aware of something – just like a coffee filter that you don't throw away until the last drop has passed through it.

You can guide the conversation with open questions and still remain with the central theme. Open questions appear easy, but you need good preparation and some practice. Even experienced salesmen tend to ask more closed questions than open ones. Under pressure, closed questions are more spontaneous than open ones. It is therefore worth preparing and rehearsing open questions until they are almost automatic.

11.4.4 Offer a solution

Now you can prepare the completion: you propose a solution and make an offer. You should do this only when you know the customer's needs exactly, because as soon as you offer solutions the needs of the customer stop growing.

11.4.4.1 BENEFIT

At the start of the solution path lies the benefit mentioned in section 11.2.1. You have researched the customer's needs, and now you can establish the benefit of your product that matches that need.

11.4.4.2 CUSTOMER-ORIENTED FORMULATION

Speak to your discussion partner. Say 'you' instead of 'I' or 'we' at least five times once in a while. If you then combine this with the customer's name you will get his or her full attention.

Use the customer's formulations: for example, if he or she speaks of 'sun collectors' you should not then speak of 'solar collectors'.

Pay attention to *how* you speak (formulate a checklist).

11.4.4.3 PRESENTATION

Nothing is as convincing as a practical example. Take your customer to see a sample system. If that isn't possible, show him or her some (good!) photos, or take models or components with you. The more sensory channels you appeal to, the better you can anchor the product in your customer's imagination. What functions for advertising can also support you: show letters from satisfied customers or testimonials from customers whose enthusiasm has already been raised as part of your advertising. When arranging your reference folder consider the current benefit arguments. Calculate an example system, and emphasize for example the monthly payments for feeding power into the grid or the monthly savings.

The iceberg is also relevant to the presentation: feel how much you enjoy your work before you ring the customer's doorbell. Then you will be able to fire a salvo of good ideas!

11.4.5 Achieve a result

Now comes the transition from the non-binding discussion to the binding deed. Do not let the right moment pass by; frequently the concluding discussions are 'talked to death'!

11.4.5.1 THE TRANSITION

CHECKLIST OF BUYING SIGNALS

- Approving comments:
 - 'That sounds good.'*
 - 'That would mean that, in future, I...'*
- Detailed questions:
 - 'Should I then have a vacuum tube collector or a flat collector?'*
- Purchase-related questions:
 - 'What would the complete system cost?'*
 - 'When could you do that?'*
- Non-verbal signals:
 - The customer moves towards you.
 - The customer goes to the product and touches it.
 - Approving nods.

The checklist of buying signals helps you to recognize that you have reached this phase in the discussion. Now you can deliberately take over the lead:

FINAL CLARIFICATION OF BUYING OBSTACLES:

- 'Can I do anything else for you?'*
- 'Who makes the decision?'*
- 'What is your time schedule?'*

Don't forget the iceberg. Assume the successful conclusion of the discussion within your own mind in advance. If you are completely convinced that you are making a good offer this will also transfer itself to the customer.

If you would like the customer to say 'yes', then you should set up a 'yes street' for him or her. Do this by using closed questions which can be answered with 'yes':

- 'Have you spoken to Mr Green about his system?'*
- 'Did he confirm my information?'*
- 'Have you looked at the promotional material?'*
- 'Does the covering frame appeal to you?'*

You must always remain confident of success. The purchase is a difficult decision for the customer, for he or she has to say goodbye to using the money for many other things. Remember the saying 'A trouble shared is a trouble halved': it helps the customer if he or she knows that it is also not easy for you. You should therefore understand the customer if he or she still has a query that takes time and trouble to sort out, or if he or she tries to extract another concession from you.

11.4.5.2 HANDLING OBJECTIONS

Objections are normal. You too would consider carefully the pros and cons of an approaching decision. It is natural to try to counter objections spontaneously, so as to be 'proved right' but this can degenerate into a fruitless battle. It is better to take seriously the thoughts of the person you are talking to and put forward alternative points of view:

'That's true: the larger tank is more expensive. But with it you will be able to store more solar energy on good days and hence bridge over longer periods of bad weather.'

It is important that the customer retains the choice, whether he or she is eventually convinced or not.

PRACTICAL TIPS

- **Echo technique.** This technique is ideal when you are surprised by sudden objections and counter-arguments from your discussion partner. You repeat what has been said in your own words and put a counter question:

'You are concerned about your roof not being leak-proof? What do you mean by that?'

In this way you gain time to 'digest' the question. The customer feels that he or she is being taken seriously and confirmed. The customer will substantiate his or her statement. You can then either dispel the worries, or you will realize that the customer really would like something else.

- **Let the garbage float past.** When you find that your customer is grumbling about really trivial things – perhaps because he or she is having a bad day – then leave it at that. Just as twigs and leaves chase about in a swollen river, you should initially not take any notice of them. If there is a genuine interest hidden among them then it will turn up again. In this way you will avoid pointless arguments.
- **Support positive statements.** If you find that the customer is more pleased about the sophisticated solar station in the cellar than the collectors on the roof, then bring it up again as a reminder during the final discussion. Perhaps you will even be able to sell him a sophisticated measured-data acquisition unit.
- **The power of silence.** When everything has been said, help the customer to clear his or her thoughts by keeping quiet.
- **Stay positive.** It doesn't always lead to an immediate signature! An agreement about the next step is also a positive outcome of a discussion.

11.4.5.3 THE QUESTION OF PRICE

It is not the price that is being sold, but the offer. If you help the customer to realize his or her desires, then the price is not the main thing.

If possible, don't mention the price until the conclusion of the discussion, when it is clear what is on offer and how it can be reduced by grants or savings. If the customer asks about the price too soon, you should respond with:

'Would you mind waiting a moment? The price depends on various options and I first want to show them to you.'

If the customer still keeps on asking about the price then tell him or her, otherwise he or she may feel that you are procrastinating.

A solar system is a long-term investment. Make the purchasing period really clear by, for example, giving the price per annum or month over the service life of the system. Alternatively, calculate in the grant and payback period immediately:

'After deducting the grant, this system will cost you €4000/\$4000/£2800 and will save you about €200/\$200/£140 per annum. In view of increasing energy prices the system will be amortized over 15 years, and over the remaining time of the 25-year service life you will earn money with it!'

A solar energy system differs from other energy converters in that it does not give rise to continuing fuel costs. Make this advantage clear:

'With a solar system you get the added bonus of free fuel for its full service life. That is the same as buying a car and at the same time 20,000 litres of petrol.'

If the customer fixes too firmly onto the price and says it is too expensive, you may be able to find out more about his or her reasons when you respond with:

'You think that this is too expensive: too expensive in relation to what?'

Do not offer any discount. Once a customer feels that it is easy to play at price negotiations with you then he or she will get you to reduce prices time and again. If



Figure 11.17.
Let the garbage float past

you *do* want to make concessions then offer more equivalent value for the same price: for example a better heat quantity meter, or an interface that enables the customer to see the yields on his or her PC.

If the customer insists on a price deduction you can ask:

'Which aspects of the performance would you then like to do without?'

'Assuming we agree on the price what is still important to you?'

'A discount is possible if you accept a larger surface area.'

Perhaps there are still options in the fine tuning: adapting the methods of payment or the payment deadline, reducing the options, or reducing risk surcharges.

The main principle should remain: *No discount without something in return.*

You must be fully confident in your prices so that during price negotiations you can remain self-assured. The customer will immediately notice if you believe your prices to be high and are unsure. Therefore calculate everything well in advance.

So now we wish you lots of success during your next sales discussion!

11.5 Subsidies

11.5.1 General information on financial support

Subsidies are important in selling solar water heaters. It is sometimes possible to add several subsidies together and make a very attractive offer to the customer. However, the acquisition of funding from third parties, such as public institutions or electric utilities, is sometimes an art in itself. Commonly, institutions giving subsidies can be classified into five groups:

- Ministries and related institutions
 - Ministry for economic affairs
 - Ministry of agriculture and/or forestry
 - Ministry for environment
 - Ministry for research and development (for innovative projects)
- Regional institutions
 - Ministries or institutions of federal states or regions
- Municipal institutions
- Independent organizations
 - e.g. environmentally focused foundations
- Energy utilities.

Usually, financial support from different state, regional or municipal support programmes can be combined in order to increase the level of support on a project. However, many support programmes limit the total rate of subsidy on a project.

Because of the frequent changes of operation of support programmes, the issuing of new programmes or the abolition of programmes, we do not give details of support programmes here but instead provide the reader with a detailed list of sources of information where overviews of support programmes and their actual conditions can be obtained for several English-speaking countries – the UK, the USA, Canada and the EU. These links will also help in acquiring information on regional programmes.

11.5.2 Sources of information in the UK

11.5.2.1 GOVERNMENT

DEPARTMENT OF TRADE AND INDUSTRY (DTI)

www.dti.gov.uk

Latest information on DTI-funded programmes for renewable energy (calls for proposals etc.).

ENERGY SAVINGS TRUST (EST)

www.est.org.uk

Information on energy efficiency and climate change; programmes for local authorities, consulting to small business.

UK GOVERNMENT NON-FOOD USE OF CROPS RESEARCH DATABASE

aims.defra.gov.uk

Lists all government-funded R&D projects on non-food crops.

OFFICE OF GAS AND ELECTRICITY MARKETS (OFGEM)

www.ofgem.gov.uk

Regulating organization for the gas and the electricity market; administers the Renewable Obligation (RO). Information on practical RO issues.

THE CARBON TRUST

www.thecarbontrust.co.uk

The Carbon Trust is developing and implementing programmes to support low carbon emitting technologies.

ENHANCED CAPITAL ALLOWANCE SCHEME (ECA)

www.eca.gov.uk

Website managed by the Carbon Trust in collaboration with DEFRA and the Inland Revenue, to provide information about the Enhanced Capital Allowance Scheme.

PRASEG

www.praseg.org.uk/

Parliamentary Renewable and Sustainable Energy Group. News on the practical implementation of support measures such as the Renewable Obligation.

11.5.2.2 FUNDING

DTI SUPPORT PROGRAMME

www.dti.gov.uk/renewable/geninfo.html

Information on UK government programmes supporting RES.

CLEAR SKIES RENEWABLE ENERGY GRANTS

www.clear-skies.org

Information on the DTI's grant scheme for renewable energy systems. The £10 million Clear Skies Initiative aims to give homeowners and communities a chance to become more familiar with renewable energy by providing grants and advice. Homeowners can obtain grants between £500 and £5000, and community organizations can receive up to £100,000 for grants and feasibility studies. Additional support on the technologies and grant applications are available through the Community Renewables Initiative or Renewable Energy Advice Centres.

Clear Skies supports projects in England, Wales and Northern Ireland. Homeowners and community groups in Scotland can apply for support under the Scottish Community Renewables Initiative.

The technologies supported are:

- solar water heating
- wind
- hydro
- ground source heat pumps
- automated wood pellet stoves
- wood fuel boilers.

Grants for photovoltaics (solar electricity) are available through the £20 million Major Demonstration Programme.

Grants will only be awarded to homeowners where an accredited installer is to be used. These installers will work to a code of practice and be vetted beforehand to ensure that the customer gets the most appropriate system for his or her needs, correctly installed at the right price.

SCOTTISH COMMUNITY AND HOUSEHOLDER RENEWABLES INITIATIVE (SCHRI)

<http://www.est.org.uk/schri/>

SCHRI offers grants, advice and project support to develop and manage new renewables schemes.

COMMUNITY RENEWABLES INITIATIVE (CRI)

www.countryside.gov.uk/communityrenewables/

Providing advice on how to set up RES projects, financing & funding, technology etc.

11.5.2.3 ASSOCIATIONS AND ORGANIZATIONS

SOLAR TRADE ASSOCIATION

www.solartradeassociation.org.uk

The Solar Trade Association Ltd (STA) serves as a focal point for organizations with business interests in the solar energy industry.

NATIONAL ASSEMBLY SUSTAINABLE ENERGY GROUP

www.naseg.org

Organization to promote sustainable development and renewable energy in Wales; special information on support programmes in Wales.

WESTERN REGIONAL ENERGY AGENCY & NETWORK

www.wrean.co.uk

Energy Agency in Northern Ireland promoting RES.

BRITISH ASSOCIATION FOR BIOFUELS AND OILS (BABFO)

<http://www.biodiesel.co.uk/>

Organization dedicated to the promotion of transport fuels and oils from renewable sources.

11.5.3 Sources of information in the USA

11.5.3.1 GOVERNMENT

DEPARTMENT OF ENERGY (DOE)

www.doe.gov

Energy policy, support programmes, links to further sources of information

11.5.3.2 FUNDING

www.science.doe.gov/grants/

Grants available through the US Department of Energy.

THE ENERGY FOUNDATION

www.energyfoundation.org

Independent foundation supported by several foundations to foster energy efficiency and clean energy; several support programmes for RES.

DATABASE ON STATE INCENTIVES FOR RES

www.dsireusa.org

Project managed by the Interstate Renewable Energy Council (IREC), funded by the DOE; information on support measures in the different states of the USA.

11.5.3.3 ASSOCIATIONS AND ORGANIZATIONS**ASES**

www.ases.org

The American Solar Energy Society (ASES) is a national organization dedicated to advancing the use of solar energy for the benefit of US citizens and the global environment. ASES promotes the widespread near-term and long-term use of solar energy.

RENEWABLE ENERGY POLICY PROJECT

solstice.crest.org

Information, insightful policy analysis and news on RES; funded by DOE, EPA and several foundations.

THE CLIMATE ARK

www.climateark.org

Portal on climate change and renewable energy; extensive information and links.

SUSTAINABLE ENERGY COALITION

www.sustainableenergy.org

Lead organization of more than 30 associations active in the field of RES; provides news on RES.

11.5.3.4 R&D AND OTHER SOURCES OF INFORMATION**NATIONAL RENEWABLE ENERGY LABORATORIES**

www.nrel.gov

Information on RES.

11.5.4 Sources of information in Canada

Links to governmental institutions, support programmes, associations and other sources of information.

11.5.4.1 GOVERNMENT**CANMET**

www.nrcan.gc.ca

Performs and sponsors energy research, technology development and demonstration within Natural Resources Canada, a department within the Canadian federal government; information on funding.

NRCAN

www.nrcan.gc.ca

Federal government department specializing in the sustainable development and use of natural resources.

CANADIAN RENEWABLE ENERGY NETWORK (CANREN)

Created through the efforts of Natural Resources Canada (NRCan); information on all renewable energy technologies.

OFFICE OF ENERGY EFFICIENCY (OEE)

oee.nrcan.gc.ca

Centre of excellence for energy efficiency and alternative fuels information.

11.5.4.2 FUNDING

RENEWABLE ENERGY DEPLOYMENT INITIATIVE (REDI)

www.nrcan.gc.ca

Support programme for RES, among them specifically for highly efficient and low-emitting biomass combustion systems.

11.5.5 EU sources

EUROPA WEBSITE

www.europa.eu.int

European Union website with general info on policies.

CORDIS

www.cordis.lu

Information on European support programmes.

SOLTHERM EUROPE INITIATIVE

www.soltherm.org

Overview of European and local markets, grants, standards and certificates.

Appendix A: Glossary

- absorber** The part of the solar collector that absorbs the incoming solar radiation, converts it to thermal energy, and feeds it into the heat transfer fluid. For an optimal conversion process at higher temperatures, the absorber is selectively coated (high absorption, low emission) and provided with a pipework system (heat transportation) through which the fluid flows (normally water or a water/antifreeze mix).
- absorption coefficient, α** The ratio of radiation absorbed by a surface to that of the incident radiation.
- albedo (or reflectance)** The ratio of solar radiation reflected by a surface to that incident on it. Examples: snow 0.8–0.9; woods 0.05–0.18.
- annuity** Describes the annual cost in terms of interest and repayments, starting with investment costs, the total period of repayments and an effective interest rate so that at the end of the period the debt has been repaid.
- aperture area** For flat collectors, the surface area of the collector opening through which unconcentrated solar radiation can enter the inside of the collector housing. For tube collectors the aperture surface of the product is calculated from the length and width of the absorber strips and the number of strips. If the gaps between the absorbers are closed with a reflector, the aperture surface increases correspondingly.
- aquifer storage** An underground, natural storage system, which serves as a seasonal store and utilizes the water-filled, porous earth layers: that is, the groundwater. Apart from water, rocks or boulders can also serve as a storage medium. Thus gravel–water storage systems are also described as aquifers.
- azimuth** The angular deviation of the collector surface with respect to the direction due south. In solar technology the azimuth angle is defined for south as $\alpha = 0^\circ$: deviation to the west is positive, to the east it is negative.
- back-up energy** The energy that the consumer uses to supplement solar energy. Examples: oil, gas or electricity.
- bleeders (air vents)** In solar loops, air gathers in the highest positions and can interrupt the circulation of the fluid. To remove this air, bleeder valves (air vents) are installed at the critical points (highest points) of the solar loop. There are manual and automatic bleeders. The bleeders must be suitable for the transfer fluid type and the maximum temperature in the solar loop.
- bypass** If the solar loop consists of long pipe runs, the installation of a short-circuit to initially circumvent the heat exchanger is recommended. During short-circuit operation the medium is heated first in the collector circuit. The pipe to the heat exchanger is only opened via a pump or motor-operated valve if the fluid has a higher temperature than the store.
- check valve** Prevents undesirable fluid movement. Check valves are installed in pipeline systems if an unwanted reversal in the normal fluid direction can take place under certain operating conditions. There are non-return flaps or valves and gravity brakes. In solar systems this type of device is used to prevent the store heat from thermosyphoning up to the collectors if the circulating pump is switched off. In the cold water feed pipe, a check valve is installed so that heated water cannot be forced out of the store back into the rising main as a result of thermal expansion.
- collector** For domestic water heating, absorbers are housed in a box or an evacuated glass tube and then covered with a highly transparent cover with thermal insulation behind. This is in order to keep the heat losses as low as possible at the higher operating temperatures. The collector is then the absorber plus these other items. If a collector is only an absorber, it may only be suitable for low-temperature applications such as swimming pools. In the case of a glazed collector a differentiation is made between the absorber surface, the aperture surface and the

gross surface. The *absorber surface* is the surface area of the absorber on which radiation is converted to heat and from which the heat is taken. The *aperture surface* is the collector opening for the solar radiation, which can then reach inside the collector housing. The *gross surface* is the total surface area of the collector (important for installation).

collector efficiency, η Gives the proportion of radiation striking the absorber surface that is converted to useful heat. It is dependent on the temperature difference between the absorber and the surroundings, and on the global solar irradiance. If the collector efficiency is represented on a diagram by means of the temperature difference between absorber and surroundings, the collector characteristic curves for a specific collector are obtained in terms of the irradiance.

convection Warm liquids or gases are lighter than cold ones and ascend. They thus carry the heat upwards. Examples: convection flows in the store (heated storage water moves upwards and cold water descends); convection losses in the collector (cooler air draws out the absorber heat and climbs upwards).

corrosion The decomposition of metallic materials. Corrosion is caused mainly by the different electrochemical potentials of two metals that are connected together so that they are electrically conducting and are wetted by an electrically conductive liquid. If corrosion is expected, suitable measures, such as the addition of inhibitors to the solar fluid or coating of system parts that are subject to weathering, should be taken to protect them from corrosion damage. In enamelled containers (solar stores) sacrificial or auxiliary current anodes are used to protect against corrosion at potential weak points. This generates a protective current in the store by means of a 'potentiostat', which prevents the precipitation of copper ions on the container wall.

CPC Compound parabolic concentrator; used in evacuated tube collectors to increase the aperture surface area by means of mirror reflectors in a geometrically optimized form as parabolic channels.

degree of efficiency, η Whenever energy is converted (such as when converting solar radiation into heat in the collector), losses occur (for example heat radiation). The degree of efficiency describes the ratio of useful energy (heat) to the energy used (solar radiation). The lower the degree of efficiency, the higher the losses. If a collector has a degree of efficiency of $\eta = 0.6$ it means that, of the radiation received, 60% is converted into useful heat, and 40% is lost in the form of optical and thermal losses.

degree of transmission, τ Part of the incoming radiation does not reach the absorber owing to reflection from the glass cover and absorption as it passes through the glass material. The degree of transmission describes the transparency of the glass pane.

degree of utilization Relates to a specific period of time – normally a year – and refers to the ratio of benefit (for example useful generated heat energy) to expenditure (energy used in the form of unburnt fuel, electrical energy or solar energy). The degree of utilization is normally lower than the degree of efficiency at the normal design point (nominal load) – that is, the utilization of a boiler, where the periods in which the boiler operates under partial load or start-up are also taken into account.

drainback system In these systems the heat transfer medium (water) is only in the collector during the pump running time, as it self-drains after the pump is switched off. On the one hand this prevents evaporation; on the other hand it means that frost protection agents are not required. Advantage: in comparison with a water/antifreeze mixture, water possesses a higher heat capacity and, as a result of its lower viscosity, causes lower pressure losses.

emission coefficient, ϵ Gives the amount of irradiated solar energy incident on the absorber (wavelengths 0.3–3.0 μm) that is radiated back again as infrared radiation (wavelengths 3.0–30 μm). An emission coefficient of 0.12 indicates that 12% of the solar energy converted to heat is radiated back.

energy Arises in different forms: thermal energy (heat), mechanical energy or electromagnetic energy (radiation). Energy is given in different units, for example as watt-hours (Wh), kilowatt-hours (kWh) or joules (J). One joule is one watt-second (Ws). 1 kWh = 1000 Wh = 3,600,000 J (= 3.6 MJ).

- expansion bellows** An intermediate piece made of corrugated copper tube. The expansion bellows compensate for temperature-related length changes to avoid cracks and leaks in the solar loop.
- expansion vessel** Part of the safety equipment for some solar hot water systems. It is a closed container with a nitrogen cushion separated by a membrane. In the event of expansion of the volume of the heat transfer liquid (water or water/antifreeze mix) caused by heating, it takes up this expansion. For a stagnation situation it also takes up the liquid content of the collector field.
- getter** To maintain a vacuum, various manufacturers integrate so-called 'getters' into the vacuum tubes. These can have either a barium sulphite coating that is vapour-deposited on the glass (that is, 'Thermomax') or copper cushions that are filled with a special granulate and fixed onto the absorber. In both cases the gas molecules are absorbed and the vacuum therefore remains stable over a long period. In the case of barium sulphite getters this process is visible by a colour change in the coating (the mirror surface becomes powdery white).
- global solar radiation** The atmosphere of the earth reduces the radiated power of the sun through absorption and scattering (= loss) by molecules, dust and clouds. The energy therefore changes direction and reaches the earth's surface partly as diffuse radiation. Without clouds, the solar energy can reach the surface directly. The term *global solar radiation* can be described as the full radiation impacting on a horizontal surface. It therefore consists of direct and diffuse radiation. With a clear sky, global solar irradiance consists only of direct radiation and with a cloudy sky only of diffuse radiation. As an annual average in northern Europe, diffuse radiation is between 50% and 60% of the global solar radiation. Diffuse radiation also heats up solar collectors.
- gross heat yield, Q_{BWE}** Corresponds to the heat discharge at the collector flow or at the inlet to the store. Measured in kWh/m². The pipe losses are included. The gross heat yields of different solar collectors can be compared only under the same temperature conditions (average absorber temperature and ambient temperature) and with the same irradiation conditions. It is also necessary to know whether it refers to the absorber, the aperture or gross surface area of the collector.
- heat loss rate, kA** The product of the heat loss coefficient, k , of the store and its surface area, A . Measured in W/K. If the kA value is multiplied by the temperature difference between the inside of the tank and its surroundings, the heat loss of the hot store is obtained. The kA value already includes the heat losses through heat leakage at the connections etc. Highly thermally insulated solar stores have kA values between 1.5 and 2 W/K, depending on size.
- heat production costs** Describes the economic viability of solar systems and gives the cost of a kilowatt-hour generated or saved with the help of the solar system. The investment and operating costs are taken into account, together with the energy savings.
- heat pipe** Vacuum tube of glass in which the absorber heat is extracted from within the glass via a closed pipe containing evaporative fluid and is then transferred to the main heat transfer fluid by means of a wet or dry manifold.
- hysteresis** The difference between the switch-on and switch-off temperatures of a relay; often found in a temperature difference controller.
- inhibitor** If different metallic materials are used in the solar loop, there is a risk of electrochemical corrosion. This can be eliminated by the addition of a suitable corrosion protection agent (inhibitor) to the heat transfer fluid. In closed systems, where the fluid contains an inhibitor, all the permitted metallic materials can be used in any combination. The inhibitor should have a certificate, which has to include details of the effective life.
- intrinsic safety** According to the Pressure Equipment Directive solar systems must be designed to be 'intrinsically safe'. Continuous heat take-up without heat consumption must not lead to a severe fault. A severe fault exists, for example, if fluid is blown out of the safety valve or vent and the solar loop has to be refilled before it is started up again. Intrinsic safety can be achieved by suitable dimensioning of all the safety devices in the solar loop.
- irradiance, G** The area-related irradiated power density of the solar radiation; measured in W/m².

***k*-value** of the collector The heat loss factor, k (unit $\text{W}/\text{m}^2\text{K}$), gives the design-specific heat loss of a collector. It describes, among other things, the insulating status of the collector. The smaller the k -value, the smaller the heat loss.

Legionella The rod-shaped bacteria that lead to Legionnaire's disease. Legionella cause two different diseases: the potentially fatal type of pneumonia, and a feverish, influenza-like illness that is not fatal. Legionella can be found in all waters except sea water. For multiplication they require, among other things, water temperatures between 30°C (86°F) and 45°C (113°F), a pH value of 6–9, and iron in dissolved or undissolved form. At temperatures above 50°C (122°F) they are destroyed. Infection takes place exclusively by breathing-in finely distributed water drops (aerosol): that is, under the shower or in 'spa baths'.

lightning protection If lightning protection is provided on the building then a solar system must also be integrated into the lightning protection system. In this case the collectors should be provided with lightning protection corresponding to the BS 6651 guidelines and installed by specialist personnel qualified for the purpose. Earth cables with a cross-section of at least 10 mm^2 (0.02 inches) and suitable tube clips are necessary.

low-flow operation Significantly reduced flow rate through a collector circuit with stronger heating of the heat transfer medium (water or antifreeze fluid) compared with normal flow (volumetric flow rate $10\text{--}15\text{ l}/\text{m}^2\text{h}$ ($0.25\text{--}0.37$ gallons ft^2/h)). Advantages: higher collector flow temperature, and hence faster availability of hot water; smaller pipeline cross-sections; lower pump power.

optical degree of efficiency (also conversion factor), η_0 The proportion of the radiation falling onto the collector that can be converted to heat in the absorber. It is the product of the degree of transmission of the transparent cover and the absorption coefficient of the absorber surface: $\eta_0 = \tau \times \alpha$. The optical degree of efficiency corresponds exactly with the collector degree of efficiency if the temperature of the absorber is equal to the temperature of the surrounding air and no thermal losses occur.

overheating protection If, during a long period of sunny weather, no energy is removed from the solar store, the temperature can climb to a maximum limit. In such a case the solar loop circulating pump must be switched off. As a result, the absorber temperature climbs to the stagnation temperature and part of the transfer fluid evaporates. To avoid this undesirable state as far as possible, it is recommended that an additional overheating protection device is used to ensure that the maximum temperature is not reached in the solar storage tank even under such conditions. For example, during critical operating phases excess energy can be fed via the auxiliary heating circuit. Glazed flat-plate collectors and vacuum tubes are designed to withstand the stagnation temperatures for a long time.

payback time The economical meaning is the amortization period of the solar system (capital repayment time). It also means the time after which the solar system has gained the exact amount of energy that was required for its production (ecological amortization time).

pellets Made from dry, unrefined scrap wood (sawdust and wood shavings). They ideally have a diameter of 6 mm (0.24 inches) and are $10\text{--}13\text{ mm}$ ($0.39\text{--}0.51$ inches) long. One kilogram of wooden pellets has a calorific value of about 5 kWh . They require only half the storage volume of bulk wood. Wooden pellet burners can be used as combination systems in connection with a solar thermal system for domestic water heating as well as for room heating support.

potential, electrochemical (electrochemical series of metals) The greater the electric potential of a metal, the more precious the metal. As the base metals are dissolved by the more precious metals, it is necessary to consider this electrochemical series when using different metals to avoid corrosion damage. In the flow direction the more base metals must follow the more precious metals.

<i>Element</i>	Lead	Tin	Copper	Zinc	Aluminium
<i>Potential</i>	0.13	0.14	0.34	0.76	1.66

power The energy consumed or provided over a given time. Its unit is the watt (W), kilowatt (kW), joule per second (J/s) or kilocalorie per hour (kcal/h). $1\text{ kW} = 1000$

$W = 1000 \text{ J/s} = 860 \text{ kcal/h}$. Example of calculating power: if a boiler provides 1500 operating hours of heat in a year and thereby generates 30,000 kWh it has an average power of 20 kW.

primary energy The energy originally provided by nature in the form of crude oil, coal, natural gas or radiation from the sun. Primary energies are partly used directly by the end user. For the most part, however, primary energy is first converted to secondary energy and then to end energy.

priority switching Pump controllers for conventional heating systems are usually designed so that the connected domestic water heating is prioritised. If the hot water temperature in the standby store falls below a set value and the store-charging pump is switched on, the heating circuit is not supplied and rapid heating of the hot water can take place. Priority switching is also effective if a solar store is connected to the storage charging circuit of a boiler that can be conventionally charged as necessary.

secondary circulation system To increase convenience, especially in the case of long domestic water pipelines, a secondary circulation system is installed that leads domestic water by means of a circulation circuit pump past the taps to the store. In this way, hot water is directly available when necessary at the taps. The circulation system can cause considerable heat losses. The important things here are the running time of the circulating pump and the quality of the thermal insulation on the circulation lines. Pressure switches and pulse-controlled or timer-controlled pumps can be installed to reduce circulation losses.

secondary energy Arises by converting primary energy: for example, coal is processed into coke or briquettes, crude oil into petrol, diesel fuel or heating oil.

selective coating On the surface of every body the heat radiation increases significantly with increase in temperature. To reduce radiation losses due to emittance (= emission) of long-wave heat radiation, the absorbers can be coated selectively in a special process. In contrast to normal black paints, this has an alternative layer structure that optimizes the conversion from short-wave to long-wave heat radiation and keeps its radiation as low as possible.

solar degree of utilization The ratio of the solar radiation striking the collector over a given time period, which has been converted into useful heat.

system efficiency Describes the efficiency of the whole solar system (collectors, pipelines, heat exchanger and storage tank). It shows how much of the solar energy irradiated to the collector can be used as hot water. It is true that over-sized systems possess a high solar fraction but, because of the non-usable excess heat in summer, they have a low degree of system efficiency.

solar fraction Also called the solar coverage rate. Indicates the ratio of the energy used for domestic water heating that can be covered by the solar system as an annual average. It corresponds with the ratio of the solar energy yield to the total energy requirement for domestic water heating, for the coverage of the solar store losses and any other losses in the circulation system.

solar constant Gives the irradiance at the upper edge of the atmosphere. It is on average 1367 W/m^2 (variations are caused by variable distances between the earth and the sun and variations of the solar activity).

stagnation temperature If the solar loop does not transmit the energy from the collector during high radiation, the absorber heats up to very high temperatures. If then the heat losses to the surroundings are just as great as the solar gain, the absorber will reach its maximum temperature. The value of the stagnation temperature is strongly dependent on the type of collector.

stratification index Represents the retention of temperature layers of fluid during draw-off. High stratification indexes mean good retention of temperature layers. The influence of the stratification index on the solar fraction is low: an increase from 30 to 100 leads to an increase in the solar fraction of about 1%.

system performance figure The ratio between the useful solar energy gained and the non-useful, parasitic electrical energy consumption of the pump and the control system.

thermosyphon principle Because of the difference in densities between warmer and cooler water, the warm water becomes more buoyant and rises upwards. This effect

is supported in good solar stores by means of internal fittings so that, even after a short solar system operating time, sufficient domestic hot water is available at the top of the tank. In gravity systems this effect is used as the only means of operating the solar loop.

thermostatic mixing valve If there is a high maximum temperature of the store, a mixing valve is required to prevent scalding when a tap is turned on. This is installed between the cold water supply pipe and the hot water take-off pipe. By means of the thermostatically controlled mixing in of cold water the maximum temperature of the water at the tap can be controlled within adjustable limits.

Tichelmann principle A collector field (array) can operate at its maximum performance only if the heat transfer medium (water or antifreeze fluid) cools the whole absorber surface area uniformly. It is thus necessary to ensure that, when the collectors are connected together, no areas are created through which the heat transfer medium either does not flow or does not flow through sufficiently. This is achieved by ensuring that all flow paths through the collector field have the same flow resistance; in other words they have the same length and cross-section. If the collectors are arranged according to the Tichelmann principle these conditions are fulfilled.

thermal conductivity, λ Characteristic value for the quality of the thermal conductance in solid bodies. The unit is W/mK. Thermal insulation has λ values between 0.035 and 0.045 W/mK.

thermal conductivity, effective vertical, λ_{eff} Gives information to show how a temperature stratification stage breaks down in a static storage tank. The effective vertical thermal conductivity should be as low as possible. Good stores without internal fittings (for example without an immersed heat exchanger) have values that are in the range of the thermal conductivity of the water itself (approximately 0.6 W/mK). For stores with internal heat exchangers, the effective vertical thermal conductivity is about 1–1.5 W/mK. Simulation calculations have shown that, by halving the effective vertical thermal conductivity from 2.2 to 1.1 W/mK, the annual solar fraction can be increased by 5%.

usable energy High-grade energy that, after conversion from low grade (that is, perhaps in a boiler), is then available in a more useful form of hot water under the shower or in the form of heat in the living areas.

viscosity The viscosity of fluids depends strongly on the temperature. The viscosity of the transfer fluid (water or antifreeze fluid) is also dependent on the concentration of any additives such as antifreeze.

Appendix B: Relevant UK solar regulations and technical standards

Note: For regulations in other countries, see also section 4.5.

Although starting from an initially simple premise of taking the sun's energy to heat water, there eventually builds a body of experience and knowledge that can be passed down through the generations. Often this is based on health and safety of workers and end-users but also it can be to improve cross-border trade or provide performance specifications. This information is predominantly found in regulations and standards, as these are the published end results of expert committees across the world.

As shown below, a regulation is an Act of Parliament, enforced as law in England and Wales. Sometimes there are variants for Northern Ireland and Scotland, but these are mainly found in the building regulations. A standard is mainly a British Standards Institution publication, but could be a code of practice published by a trade organization. Sometimes regulations refer to standards, and hence they also become enforceable in law. The enforcement is normally by the Health and Safety Executive, but building control officers and water utilities also have a role.

B.1 General construction regulations

Water Supply (Water Fittings) Regulations 1999
 The Building Regulations 2001
 The Pressure Equipment Regulations 1999
 Control of Substances Hazardous to Health Regulations 1999
 Gas Safety (Installation and Use) Regulations 1998

B.2 General construction standards

BS 6700: 1997 Design, installation, testing and maintenance of services supplying water for domestic use within buildings and their curtilages
 BS 5449: 1990 Specification for forced circulation hot water central heating systems for domestic premises
 BS 7671: 2001 16th Edition IEE Wiring Regulations
 BS 6651: 1992 Code of practice for protection of structures against lightning

B.3 Solar standards

BS 6785: 1986 Solar heating systems for swimming pools
 BS 5918: 1989 British Standard Code of Practice for solar water heating systems for domestic hot water
 BS EN 12975 2001: Thermal solar systems and components – Solar collectors
 BE EN 12976 2001: Thermal solar systems and components – Factory made systems
 DD ENV 12977: Thermal solar systems and components – Custom made systems
 BS EN ISO 9488: 2000 Solar energy vocabulary

B.4 Roof standards

General and pitched roofs: BS 8000, BS 6399, BS 5534, NFRC
 Flat supported (felt, asphalt, liquid): BS 6229, BS 8217, BS 8218, FRCAB, NFRC, ELRA
 Flat self-supporting (metal profile, fibre-cement): BS 5427, CP143, MCRMA, NFRC
 Metal supported (copper, zinc, lead, aluminium): BS 6915, CP143, LSA, MCRMA

B.4.1 ACRONYMS FOR ROOF STANDARDS

BS: British Standard
CP: Code of Practice (BS)
CITB: Construction Industry Training Board
ELRA: European Liquid Roofing Association
FRCAB: Flat Roofing Contractors Advisory Board
LSA: Lead Sheet Association
MCRMA: Metal Cladding and Roofing Manufacturers Association Limited
NFRC: National Federation Roofing Contractor
NVQ: National Vocational Qualification
RIA: Roofing Industry Alliance

B.5 Working on site, height and lifting regulations

HEALTH & SAFETY AT WORK ACT (HSW) 1974

Applies to all employers, employees, self-employed.

MANAGEMENT OF HEALTH AND SAFETY AT WORK REGULATIONS (MHSWR) 1999

Apply to all employers, employees, self-employed. Assess and reduce risks.

CONSTRUCTION (HEALTH, SAFETY & WELFARE) REGULATIONS 1996

Apply to all construction work employers, employees, self-employed and all those who can contribute to the health and safety of a construction project.

Note: Regulation 6 covered under 'Work at height' legislation.

CONSTRUCTION REGULATIONS (HEAD PROTECTION) 1989

Apply to all requiring head protection.

CONSTRUCTION (DESIGN AND MANAGEMENT) REGULATIONS (CDM) 1994

Apply to all large-scale, non-domestic work.

LIFTING OPERATIONS AND LIFTING EQUIPMENT REGULATIONS (LOLER) 1998

Apply to all lifting equipment.

MANUAL HANDLING OPERATIONS REGULATIONS 1992

Apply to employers and the moving of objects by hand or bodily force.

PROVISION AND USE OF WORK EQUIPMENT REGULATIONS (PUWER) 1998

Apply to all equipment providers, including machinery that should be safe for work.

THE WORKPLACE (HEALTH, SAFETY AND WELFARE) REGULATIONS 1992

Apply to employers regarding ventilation, heating, lighting, workstations, seating and welfare facilities.

HEALTH AND SAFETY (FIRST AID) REGULATIONS 1981

Provision of suitable first aid facilities and at least one trained first aider.

REPORTING OF INJURIES, DISEASES AND DANGEROUS OCCURRENCES REGULATIONS (RIDDOR) 1995

Require employers to notify certain occupational injuries, diseases and dangerous events.

NOISE AT WORK REGULATIONS 1989

Require employers to take action to protect employees from hearing damage.

ELECTRICITY AT WORK REGULATIONS 1989

Require people in control of electrical systems to ensure they are safe to use and maintained in a safe condition.

PERSONAL PROTECTIVE EQUIPMENT AT WORK REGULATIONS 1992

Apply to employers for the provision, use and storage of appropriate protective clothing and equipment.

Appendix C: Nomenclature

C.1 Radiation

ϕ	(W)	Irradiated power
G	(W/m ²)	Irradiance, power density of radiation incident on a surface
I_0	(W/m ²)	Solar constant (1.367 ± 7 W/m ²)
G_U	(W/m ²)	Useful radiation
G_G	(Wh/m ² , kWh/m ²)	Global solar irradiance
G_{dif}	(Wh/m ² , kWh/m ²)	Diffuse radiation
G_{dir}	(Wh/m ² , kWh/m ²)	Direct radiation
G_{col}	(Wh/m ² , kWh/m ²)	Radiation on collector surface
E_G	(kWh/m ² a)	Yearly solar irradiance

C.2 Heat

\dot{Q}	(W/m ²)	Thermal output
\dot{Q}_L	(W/m ²)	Thermal loss
Q	(Wh, kWh)	Heat quantity
Q_N	(Wh, kWh)	Useful heat quantity
\dot{Q}_N	(W, kW)	Useful thermal output
Q_S	(Wh, kWh)	Solar heat yield, gain
Q_{aux}	(Wh, kWh)	Auxiliary heat
Q_{MW}	(Wh, kWh)	Domestic water heat requirement
Q_{BWE}	(kWh/m ² a)	Gross thermal yield

C.3 Thermal losses

k	(W/m ² K)	Thermal loss coefficient
k_1	(W/m ² K)	Linear thermal loss coefficient
k_2	(W/m ² K)	Quadratic thermal loss coefficient
k_{eff}	(W/m ² K)	Effective thermal loss coefficient
kA	(W/K)	Thermal loss rate
λ_{ev}	(W/m ² K)	Effective vertical thermal conductivity

C.4 Temperature

θ	(°C)	Temperature
θ_E	(°C)	Entry temperature into the heat exchanger
θ_A	(°C)	Exit temperature from the heat exchanger
$\theta_{absorber}$	(°C)	Average absorber temperature
θ_{air}	(°C)	Air temperature
$\Delta\theta$	(K)	Temperature difference
$\Delta\theta_{off}$	(K)	Switch-off temperature difference of controller
$\Delta\theta_{on}$	(K)	Switch-on temperature difference of controller
T	(K)	Absolute temperature

C.5 Efficiency

η	(%)	Degree of efficiency
η_o	(%)	Degree of optical efficiency

η_{sys}	(%)	Degree of system efficiency
η_{vent}	(%)	Degree of fan efficiency

C.6 Pressure

p	(bar)	Pressure
p_{in}	(bar)	Initial pressure
p_{max}	(bar)	Max. permissible pressure
p_{Bmax}	(bar)	Max. permissible operating pressure
$p_{\text{max,SV}}$	(bar)	Response pressure of safety valve
Δp	(mbar)	Pressure loss
Δp_{tot}	(bar)	Total pressure loss in solar loop
Δp_{col}	(bar)	Pressure loss in collector
$\Delta p_{\text{heat exch}}$	(bar)	Pressure loss in heat exchanger
Δp_{piping}	(bar)	Pressure loss in pipelines
$\Delta p_{\text{fittings}}$	(bar)	Pressure loss in fittings

C.7 Material-specific variables

α	(mm/mK)	Expansion coefficient
λ	(W/mK)	Thermal conductivity
α	(%)	Absorption coefficient
ϵ	(%)	Coefficient of emission
τ	(%)	Coefficient of transmission
ρ	(%)	Coefficient of reflection
c_{W}	(Wh/kgK)	Specific heat capacity of water (1.16 Wh/kgK)
$c_{\text{G,W}}$	(Wh/kgK)	Specific heat capacity of solar liquid (antifreeze fluid: 1.03 Wh/kgK)
c_{L}	(Wh/kgK)	Specific heat capacity of air (0.28 Wh/kgK)

C.8 Volume, volumetric flow rate and flow speed

V	(l)	Volume
V_{MEVmin}	(l)	Minimum size of expansion vessel
V_{D}	(l)	Expansion volume
V_{HW}	(l)	Daily hot water consumption
V_{tot}	(m ³ /m ² h)	Specific volumetric flow rate of air
V_{min}	(m/s)	Minimum flow speed
V_{L}	(m ³ /h)	Hourly airflow rate requirement

C.9 Angles

α_{S}	(°)	Azimuth angle of sun
γ_{S}	(°)	Angular height of sun
α	(°)	Azimuth angle of surface
β	(°)	Inclination angle of surface

C.10 Surfaces and lengths

A	(m ²)	Absorber surface area
A_{min}	(m ²)	Minimum absorber surface area
A_{max}	(m ²)	Maximum absorber surface area
A_{O}	(m ²)	Free-flow cross-section of absorber
h_{sys}	(m)	System height (height of expansion vessel to top edge of collector)
Δl	(mm)	Temperature-related length change

l_0	(m)	Original length
h	(m)	Collector height
X	(m)	Space between collector rows
AM	(-)	Air mass factor

C.11 System variables

SF	(%)	Solar fraction
SE	(%)	System efficiency
P_F	(W, kW)	Fan power

C.12 Financing

a	(-)	Annuity factor
A_0	(£/\$/£)	Procurement cost of system
T	(a)	Time period considered in years
q	(-)	Interest factor = $1 + (p/100)$
p	(%)	Interest
f_k	(%,a)	Factor for acquiring the servicing (costs)
AN_o	(-)	Annuity for operation-related costs
AN_i	(-)	Annuity for investment-related costs
AN_s	(-)	Annuity for servicing-related costs
AN_c	(-)	Annuity for capital-related costs

C.13 Constants

σ	(W/m ² K ⁴)	Stefan–Boltzmann constant (5.67×10^{-8} W/m ² K ⁴)
----------	------------------------------------	---

References and further information

References

- 1 Möller F, *Einführung in die Meteorologie*, Band 2, BI Hochschultaschenbücher, 1984
- 2 *Das Sonnenenergieangebot und dessen Nutzung in Berlin*, DGS Landesverband Berlin Brandenburg, 1995
- 3 Scheer H, *Solare Weltwirtschaft*, Verlag Antje Kunstmann, 1999
- 4 Schindler J and Zittel W, Public hearing of experts of the Enquiry commission of the German parliament *Nachhaltige Energieversorgung unter den Bedingungen der Globalisierung und der Liberalisierung* on the theme of worldwide development of the energy demand and the availability of resources, 2000
- 5 *IEA World Energy Outlook*, 1998
- 6 Graßl H and Klingholz R, *Wir Klimamacher*, S. Fischer-Verlag, 1990
- 7 Stryi-Hipp G, *Der europäische Solarthermie-Markt*, DFS, 2001
- 8 *Selektive Absorberbeschichtungen in Solarkollektoren*, BINE Projektinfo 5/99
- 9 Ladener H and Späte F, *Solaranlagen*, 6th Edition 1999, page 78
- 10 *Sanitär- und Heizungstechnik*, 1–2000, page 38
- 11 *Technische Information Tyfocor L 4.80*, Solvis Energiesysteme
- 12 Ladener H and Späte F, *Solaranlagen*, 6th Edition 1999, page 99
- 13 Schmidt H, *Umsetzung der Funktionskontrolle des FUKS-Projektes in marktfähige Regler*, 10. Symposium Thermische Solarenergie, 2000
- 14 *Sonne, Wind und Wärme*, Heft 2, 2000, page 22
- 15 Jahn K and Schwenk C, *Thermische Solaranlagen für Mehrfamilienhäuser*, Bremer Energieinstitut, 1999
- 16 Hessisches Ministerium für Umwelt, Energie, Jugend, Familie und Gesundheit und HessenEnergie GmbH: *Leitfaden Solarthermische Anlagen*, 1993
- 17 Ladener H and Späte F, *Solaranlagen*, 6th edition, 1999, page 165
- 18 After Recknagel and Sprenger, *Taschenbuch für Heizung und Klimatechnik*, 2000, page 1736
- 19 Morsch R, TU Berlin, Seminarunterlagen
- 20 Schreier N, Wagner A, Orths R and Rotarius T, *So baue ich eine Solaranlage*, Wagner & Co Solartechnik GmbH, Cölbe 1999, page 100
- 21 Schreier N, Wagner A, Orths R and Rotarius T, *So baue ich eine Solaranlage*, Wagner & Co Solartechnik GmbH, Cölbe 1999, page 66
- 22 Schreier N, Wagner A, Orths R and Rotarius T, *So baue ich eine Solaranlage*, Wagner & Co Solartechnik GmbH, Cölbe 1999, page 118
- 23 Schreier N, Wagner A, Orths R and Rotarius T, *So baue ich eine Solaranlage*, Wagner & Co Solartechnik GmbH, Cölbe 1999, page 120
- 24 Ladener H and Späte F, *Solaranlagen*, 6. edition 1999, page 186
- 25 Lambrecht K et al., *EUPOS-Handbuch Solarthermie*, DGS München, 1999
- 26 Batran B et al., *Fachwissen Bau, Zimmerer, Handwerk und Technik*, Hamburg, 1998
- 27 Arbeitsgemeinschaft Ziegeldach e.V., Bonn
- 28 A.W. Andernach GmbH & Co. KG, Bonn
- 29 Saar-Gummiwerk GmbH, Wadern-Büschfeld
- 30 Holzapfel W, *Werkstoffkunde für Dach-, Wand- und Abdichtungstechnik*, Rudolf Muller, Köln, 1999
- 31 Recknagel and Sprenger: *Taschenbuch für Heizung und Klimatechnik*, 2000, page 377
- 32 Delzer T and Remmers K-H, *Solardachfibel*, Solarpraxis 1998, page 4
- 33 *Dacharbeiten*, BG der Bauwirtschaft
- 34 Delzer T and Remmers K-H: *Solardachfibel*, Solarpraxis 1998, page 130 ff
- 35 Rockendorf G, *Fassadenintegration von thermischen Sonnenkollektoren*, ISFH, 2000

- 36 *Wärmedämmwerte verschiedener Materialien*, 10th Symposium Thermische Solarenergie, 2000, S. 74
- 37 Ladener H and Späte F, *Solaranlagen*, 6. edition 1999, page 216
- 38 von Braunmühl, W, *Handbuch Contracting*, Krammer Verlag, Dusseldorf, 2000
- 39 Verband für Wärmelieferung e.V.: *Energieförderung*, VfW Jahrbuch 2000, Hannover
- 40 Bremer Energy Institute
- 41 FHH Umweltbehörde: Hamburg setzt auf Sonnenwärme, 2000
- 42 Professional experience with solar district heating in the German project Friedrichshafen/Wiggenhausen-Süd
- 43 *Sun in Action II: A Solar Thermal Strategy for Europe*, European Solar Thermal Industry federation, April 2003, downloadable from www.estif.org
- 44 Landesgewerbeamt Baden-Württemberg, Informationszentrum Energie: *Rationelle Energieverwendung in kommunalen Freibädern*, 1995
- 45 Schreier N, Wagner A, Orths R and Rotarius T, *So baue ich eine Solaranlage*, Wagner & Co Solartechnik GmbH, Cölbe 1999
- 46 Hindenburg C, Henning H-M and Schmitz G, *Einsatz von Solarluftkollektoren in Sorptiongestützten Klimatisierungssystemen*, Achtes Symposium Thermische Solarenergie, OTTI, Staffelstein, May 1998
- 47 GBU mbH, Bensheim, Germany, www.gbunet.de
- 48 Bine ProjektInfo 08/2002: <http://194.175.173.199>
- 49 ZAE Bayern: <http://www.zae-bayern.de>
- 50 Henning H-M, *Auslegung von Solaren Klimatisierungssystemen*, Achtes Symposium Thermische Solarenergie, OTTI, Staffelstein, 2000
- 51 Hindenburg C and Dotzler W, *Neuentwicklung eines Solarluftkollektors in Modulbauweise*, Achtes Symposium Thermische Solarenergie, OTTI, Staffelstein, 2002
- 52 Binder-Kissel-Beratung und Training, Freiburg, Germany. www.binder-kissel.de
- 53 Prose F and Wortmann K, *Konsumentenanalyse und Marktsegmentierung der Kunden der Stadtwerke Kiel*, Universität Kiel, 1991
- 54 Wittbrodt E, *Kunden binden mit Kundenkarten*, Luchterhand Verlag, 1995

For further information

ISES, the International Solar Energy Society, has a large on-line library of documents called WIRE available on <http://wire.ises.org>.

More information is given on different countries in Section 4.5.

Index

- absorbers
 - advantages/disadvantages 22
 - air-operated solar systems 224–5, 247–8
 - bonding 216
 - characteristic curves 198, 199
 - clamping 215–16
 - coatings 22
 - collectors 18–22, 24, 31
 - cushion absorbers 22, 24
 - design 198–200
 - efficiency 198, 199
 - evacuated tube collectors 31
 - flat absorbers 198–200
 - flow 213–14, 224–5
 - glazed flat-plate collectors 22, 24
 - ground level installation 217
 - heat transfer 17–18
 - materials 202, 203
 - mechanical fixings 214–16
 - mounting rails 215
 - operating principles 17–18
 - pressure loss 201
 - surface area 78, 211–14
 - swimming pool heating 197–201, 207–9, 211–17
 - tension belts 215–16
 - tube absorbers 198–200
 - unglazed collectors 19, 21
 - wind speed 198, 199
 - yields 198, 199
- absorption
 - matter interactions 23
 - solar radiation 4–5, 23
- access safety 108–10
- ad/absorption chillers 255–7, 259, 263–4, 270, 273
- air bleed 52–4, 141–2
- air circulation systems 234–5
- air collectors 19, 265, 266–8
- air-conditioning systems 253–73
 - air-operated solar systems 234–5
 - system design 268–73
 - system technology 262–8
- air flow rates 242–3
- air heating systems 234–41
- air mass factor (AM) 4–5
- air-operated solar systems 223–51
 - absorbers 224–5, 247–8
 - airflow rates 242–3
 - air heating systems 234–41
 - air-to-water heat exchangers 244–5
 - air-water heat transfer units 230–1
 - ambient air 234–5, 242
 - blowers 229–30
 - central systems 234
 - collectors 224–9, 235–9, 246–8
 - components 224–34
 - controllers 233–4
 - cooling systems 265, 266–8
 - costs 248–9
 - covers 225
 - decentralized systems 234
 - dimensioning 242–6
 - domestic water heating 233, 237–9
 - drying 239–40
 - efficiency factors 225–6, 242, 248–9
 - examples 249–51
 - facade collectors 228
 - facade integration 247–8
 - factories 240–1
 - fan power 244
 - fans 229–30, 244, 248
 - fresh air systems 235, 236
 - halls 240–1
 - heat exchangers 230–2, 244–5
 - heat recovery 230–2, 238–9
 - heat stores 236–7, 238–9
 - housing construction 235–9
 - hybrid systems 228, 234–5
 - hypocaust systems 237
 - installation 246–8
 - low-energy houses 238–9
 - materials 225
 - office buildings 240–1
 - performance 225–6
 - photovoltaics 227–8, 233–4
 - pipng 230, 248
 - planning 242–6
 - recovery-solar boxes 231–2
 - regulators 233
 - roofs and roofing 227, 246–8
 - sensor positioning 233
 - solar boxes 231–2
 - solar drying 239–40
 - standard air collectors 224, 225, 226–7
 - surface areas 242–3
 - systems 234–41
 - system sizing 245–6
 - temperature difference controllers 233–4
 - ventilation 234–41
 - volumetric flow 244–5
 - water heating 233, 237–9
 - yields 248–9
 - see also* air-conditioning systems
- air separators 135
- air-to-water heat exchangers 244–5
- air-water heat transfer units 230–1
- AM *see* air mass factor
- ambient air 234–5, 242
- anchoring fittings 118–21, 218
- angle of inclination 8–10, 328
- angular angles 328
- annuity method 94–5, 172–4, 329
- anode storage tanks 139

- aperture areas 18
- appendices 319–32
- approximation formulation
 - collectors 152–3
 - size determinations 81–3
 - storage tanks 152–3
 - swimming pool heating 211–14
 - water heating dimensioning 81–3, 90
- aquifer storage 180
- assembly errors 139–46
- astronomical bases 1–8
- atmospheric absorption 4–5
- atmospheric reflection 4
- Australia 3, 6, 18, 37, 67, 146–7
- Austria 45, 305, 306
- automatic controllers 56
- autonomous solar-powered systems 262–3, 271
- auxiliary heating 67, 69, 93, 208–10, 265–8
- azimuth angles 4–5, 9–11, 328

- baffle plates 39
- batch collector systems 29
- Belgium 34, 305, 306, 307
- belt dryers 239–40
- Berlin 282–3
- biomass 192, 239–40
- bitumen 100, 101
- blending valves 46
- blowers 229–30
- boilers
 - heat stores 40–5
 - operating principles 17
- boiling temperatures 49
- bonding methods 107, 216
- breakage, ice formation 140
- buffer stores 40
 - circuit discharging 161–2, 165–8
 - heat exchangers 69–70, 71, 73
 - large-scale systems 153–62
 - safety 170–1
- bypass circuits 158–9

- calculation methods
 - shading 10
 - simulation programs 277–293
 - temperatures 90
 - volumetric flow 83–4
 - water heating components 83–9, 90
- Campbell–Stokes sunshine recorders 8
- Canada 17, 147, 250–1, 307, 315, 317–18
- capillary effect 106–7
- capillary soldering 110
- capital-related costs 172–4
- carbon dioxide 13–15
- carry over 259
- Central Europe
 - cooling systems 253, 254, 262, 267, 271
 - domestic systems 73, 77, 78, 83, 89–91
 - installation methods 107, 122
 - large-scale systems 165, 196
 - solar radiation 2, 5, 9, 10
 - swimming pools 197, 210, 219
 - system components 27, 33
 - see also individual countries*
- characteristic curves 26–7, 35, 198, 199
- charging/discharging 68–70, 154–5, 157–62, 165–8
- check valves 134
- chillers 255–7, 259, 263–4, 270, 273
- chimneys 121
- chlorine 106
- circuit discharging 157, 161–2, 165–8
- circuit pumps 207–8
- circulating pumps 82–3, 85–7, 134
- circulation lines 80–1
- circulation system integration 156
- clamps 127, 222
- classification, simulation programs 276
- cleaning requirements 10–11
- climate change 13–15
 - carbon dioxide 13–15
 - consequences 14–15
 - global warming 14–15
 - greenhouse gases 13–15
 - methane 13
 - nitrous oxides 13
 - non-renewable energy sources 15
 - sulphur dioxide 13
- closed volumetric receivers 194–5
- closed water heating systems 67
- cloud cover 4–5
- cold water connection 130–2
- collar beams 98
- collection pipes 217–18
- collectors
 - absorbers 18–22, 24, 31
 - accessories 34
 - advantages/disadvantages 22, 27, 35
 - air collectors 19, 227–8
 - air-operated solar systems 224–9, 235–9, 246–8
 - aperture areas 18
 - approximation formula 152–3
 - assembly errors 142–3
 - azimuth 9–10
 - characteristic curve equation 26–7, 35
 - collector circuits 157–9, 164–5, 169–70
 - collector fields 124–6, 152–3, 168–9
 - cooling systems 263–4, 265–8, 270–1
 - curve equation 26–7, 35
 - direct flow-through evacuated tubes 31–2
 - double evacuated tubes 20
 - efficiency 24–7, 33, 35, 185–6, 225–6
 - energy balance 92–4
 - energy yields 21, 185–6
 - evacuated tubes 20, 30–5, 50, 185, 186, 188
 - evaporation 168–9
 - facade installation 122–4
 - fault detection/rectification 145
 - flat-plate 19–30, 92–4, 185, 186, 188
 - flow on both sides of absorber 224, 225
 - flow over absorber 224
 - flow through absorber 224, 225
 - flow under absorber 224, 225, 226–7
 - glazed flat-plate 21–30, 185, 186, 188
 - heat exchangers 164–5
 - heat insulation 19
 - heat-pipe evacuated tubes 20, 32–3
 - heat stores 157–9
 - hybrids 29–30, 228
 - inclination angles 9–10
 - installation 112–26
 - insulation 19, 23–4, 30–1
 - interconnections 242–3
 - irradiance 24–5, 26
 - irradiation 122
 - k*-values 26–7, 33
 - limited convection 19
 - maintenance 136
 - matrix collectors 224, 225
 - operating principles 18–35
 - optical efficiency 26–7, 33

- optical losses 26–7
- parabolic trough 185, 188, 189–93
- performance 225–6
- photovoltaics-integrated air 227–8
- pressure losses 83–7
- radiation sensors 159
- reference areas 21
- roofs and roofing installation 112–26
- safety 168–70
- seals 24
- sensors 159
- shading 122
- shielding angles 122
- skylights 28–30
- solar concentrating systems 184–93
- solar liquids 50
- special designs 27–30
- stagnation temperatures 35
- standard flat 19
- steam generation 35
- surface areas 18, 20–1, 81–3, 152–3, 242–3, 270–1
- surface orientation 90
- Sydney tubes 20, 32
- temperature difference 145
- temperature sensors 159
- thermal losses 26–7
- tilted roof mounting 103, 104
- transparent heat insulation collectors 19
- transpired air 229
- unglazed 19, 21
- vacuum collectors 19, 20, 30–5, 50, 185, 186, 188
- yields 21, 185–6
- combination/combined heat stores 40–5, 73
- commissioning 136–8
 - assembly errors 143
 - controllers 138
 - heat transfer 137–8
 - leak testing 137
 - pumps 138
 - solar circuit 136–7
 - solar liquid 137–8
 - water heating 91, 93
- component calculations 83–9
- compression 36, 110, 253, 255–6, 272
- computer-aided methods 10–11, 90, 214, 245–6
 - see also* simulation programs
- concentrating systems *see* solar concentrating systems
- concrete slab fixings 215
- conductivity 48, 223
- connections
 - assembly errors 141–2
 - cold water connection 130–2
 - collector field construction 125–6
 - controllers 65
 - heat stores 129, 130–2
 - hot water connections 131–2
 - pipe installation 110–11
 - solar circuits 130
 - Tichelmann connections 125, 209, 213
 - water heating 91, 93
 - wet connections 33
 - Z-connections 125, 209, 213
- consumption determination 78–9
- consumption profiles 150, 151
- consumption-related costs 172, 174
- continuous analysis 59
- contracting 174–7
- controllers
 - air-operated solar systems 233–4
 - assembly errors 143
 - commissioning 138
 - connecting cables 65
 - control unit installation 136
 - data transmission 59–60
 - digital 55–6
 - error signals 59–60, 63–4
 - function 59–60
 - heating support systems 57, 58
 - heat meters 59, 60–2, 63
 - heat stores 156–62
 - hot water installations 57
 - installation, roofs and roofing 136
 - multi-function controllers 58
 - operating principles 17–18, 55–66
 - overheating protection 49, 65–6
 - radiation measurements 65
 - sensor housing 65
 - swimming pool heating 204–6
 - temperature difference 59
 - temperature sensors 60, 62–5
 - water heating 91, 93
 - yield control 59, 60–2, 63
- convection 19
- convection brakes 132, 133
- cooling systems 253–73
 - ad/absorption chillers 255–7, 259, 263–4, 270, 273
 - air collectors 265, 266–8
 - air-conditioning systems 253–73
 - autonomous solar-powered systems 262–3, 271
 - auxiliary heating 265–8
 - chillers 255–7, 259, 263–4, 270, 273
 - circuit variants 264–8
 - collectors 263–4, 265–8, 270–1
 - compression refrigeration systems 253, 255–6, 272
 - cooling loads/capacity 254, 257, 261, 263, 267–71
 - costs 261–2, 269, 272
 - desiccant air-conditioning 255, 257–9, 263–4, 270
 - energy savings 271–3
 - facade integration 264
 - heat capacity 269
 - heating loads 254, 261, 269
 - heat recovery 259
 - heat stores 265–8, 269
 - humidity 257–8, 259, 261
 - liquid sorbents 258–9
 - peak loads 270–1
 - planning 259–62
 - prices 261, 264
 - primary energy savings 271–3
 - refrigeration systems 253–4, 255–6
 - shading 260, 264
 - solar air collectors 265, 266–8
 - solar-assisted systems 262–3
 - solar fractions 272–3
 - solar liquid 265–6
 - solid sorbents 257–9
 - sorbents 257–9
 - storage tanks 146, 265–8, 269
 - swimming pool heating 206
 - system design 268–73
 - system technology 262–8
 - temperature levels 257–8, 261

- theoretical bases 255–9
- thermally driven processes 255–9, 263–4
- corrosion/corrosion protection 48, 106–7, 138–9
- costs
 - air-operated solar systems 248–9
 - concentrating systems 188, 196
 - cooling systems 261–2, 269, 272
 - domestic water heating 90–5
 - large-scale systems 172–7
 - nomenclature 329
 - swimming pool heating 219–20
 - water heating 90–5
- counterweights 117
- coverings
 - air-operated solar systems 225
 - roofs and roofing 98–103, 113–14
 - swimming pool heating 206
- cranes 110
- creep 48
- crimped pipe connections 110
- curve equation 26–7, 35, 198, 199
- cushion absorbers 22, 24
- damage
 - propylene glycol 141
 - thermal insulation 140
- data transmission 59–60
- decentralized systems 234
- defects and faults 139–46
- dehumidification 259
- delivery correctness/completeness 111
- Denmark 89, 178, 228, 305, 306
- density
 - air and water 223
 - heat stores 45–6
 - operating principles 17
 - solar liquids 49
- desiccant air-conditioning 255, 257–9, 263–4, 270
- diffuse radiation 2, 3, 6
- digital controllers 55–6
- dimensioning
 - air-operated solar systems 242–6
 - large-scale systems 152–3
 - simulation programs 275–293
 - swimming pool heating 211–14
 - water heating systems 74–90
- direct flow-through evacuated tube collectors 31–2
- direct irradiation 196
- direct radiation 2, 3, 6
- dirt filters 135, 136
- discharging 68–70, 154–5, 157–62, 165–8
- dish/Stirling systems 195–6
- dishwashers 46
- disinfection 153–4
- display instruments 135
- distribution pipes 217–18
- district heating 177–82
- domestic hot water systems 37–40, 135–6
- domestic water heating systems 67–95
 - air-operated solar systems 233, 237–9
 - charging/discharging 68–70
 - costs 90–5
 - planning and dimensioning 74–90
 - space heating 72–4
 - standard system 70–1
 - swimming pool heating 210–11
- domestic water stores 37–40, 135–6, 153–6
- double evacuated tube collectors 20
- drainback systems 17, 67, 72, 169
- draining valves 131
- drain taps 135
- drying systems 239–40
- dual-source heating 213
- dust 10–11
- earthing/earth reservoirs 91, 93, 179–80
- earth probe systems 180
- economic considerations 172–7, 188, 196, 329
 - see also* costs
- effective collector area 18, 20–1
- efficiency
 - absorbers 198, 199
 - air-operated solar systems 225–6, 242, 248–9
 - collectors 24–7, 33, 35, 185–6, 225–6
 - nomenclature 327–8
 - water heating 78, 94
- electricity generation 189–96
- elevation angles 4–5, 10–11
- emissivity 23
- energy
 - balance 92–4
 - contents 36
 - cubes 11–12
 - density 45–6
 - resource finiteness 11–12
 - savings 271–3
 - yields 21, 185–6
- enthalpy 259
- errors, servicing 139–46
- error signals 59–60, 63–4
- Europe
 - information sources 318
 - marketing and promotion 318
 - networks 305–7
 - Northern Europe 17, 67, 77
 - Southern Europe 67, 122, 186, 253
 - Standard EN 12976 47, 54, 65
 - water heating dimensioning 89–91
 - see also* Central Europe; *individual countries*
- evacuated tube collectors 20, 30–5, 50, 185, 186, 188
- evaporation 168–9
- expansion coefficients 105
- expansion vessels
 - false connections 141–2
 - safety 171
 - solar circuits 47, 55, 134
 - water heating 82–3, 87–9
- external heat exchangers 51–2, 68, 71, 130, 163–4
- facade collectors 228
- facade installation 122–4
- facade integration 247–8, 264
- factories, air-operated solar systems 240–1
- false connections, expansion vessels 141–2
- fans, air-operated solar systems 229–30, 244, 248
- faults and defects 139–46
 - detection/rectification 143–6
- f*-charts 277–8
- feed temperatures 90
- filled systems, water heating 67
- financing nomenclature 329
- finned tube heat exchangers 51, 130
- fittings installation 110, 118–21, 127, 133–6, 218
- fixings
 - absorbers 214–16

- concrete slab fixings 215
- pipe installations 111
- flat absorbers 198–200
- flat collectors 19
- flat-plate collectors 19–30, 92–4, 185, 186, 188
- flat roofs 34, 97–8, 101, 103–4, 117–22, 246–7
- flow on both sides of absorber collectors 224, 225
- flow gauges 145
- flow meters 54, 60, 135, 145
- flow over absorber collectors 224
- flow rates 145, 242–3
- flow-through absorber collectors 224, 225
- flow-through evacuated tube collectors 35
- flow-through principle 71
- flow under absorber collectors 224, 225, 226–7
- flushing out solar circuits 136–7
- forced circulation systems 67
- fossil fuels 11–12
- four-wire circuits 64
- France 254, 273, 315, 316, 317
- fresh air systems 235, 236
- Fresnel principle 190–1
- frost protection 49, 136
- full-usage hours 89–90

- gas combination storage systems 42, 43
- gas reserves 12
- GasSolar combination storage systems 42, 43
- General Motors, Ontario 250–1
- Germany
 - air systems 249–50
 - Berlin 282–3
 - concentrating systems 193–4
 - cooling systems 253, 258
 - domestic systems 89
 - heat stores 170
 - large-scale systems 179, 186
 - marketing and promotion 315, 316
 - pressure vessel regulations 170
 - roofs and roofing 109
 - safety 168
 - solar radiation 6
 - system components 29, 34, 37, 46
- GetSolar program 283–4
- glazed flat-plate collectors 21–30, 92–4, 185, 186, 188
- global solar irradiance 2, 3, 5–7, 9
- global warming 14–15
- glossary 319–24
- glycol 48–50, 141
- Grammer system 247
- graphical methods 10, 89
- grass root roofs and roofing 101
- Greece 196, 305, 306
- greenhouse gases 13–15
- grid independent air collectors 227–8
- gross surface areas 18
- ground level installation 217
- guy ropes 117

- halls 240–1
- harnesses 109
- header pipes 201–3
- health and safety 107–8, 336
 - see also* safety
- heat capacity 223, 269
- heat exchangers
 - advantages/disadvantages 163–4
 - air-operated solar systems 230–2, 244–5
 - buffer stores 69–70, 71, 73
 - collector circuits 164–5
 - heat stores 39, 69–70, 71, 73, 158–9, 162–8
 - large-scale systems 158–9, 162–8
 - limescale 51
 - operating principles 17–18
 - solar circuits 47, 51–2, 130
 - solar energy chargers 68
 - storage tank charging 154–5, 159–62, 165–6
 - swimming pool heating 203–4
 - thermal stores 69–70, 71, 73
 - water heating 68, 69–70, 71
- heating loads 89–90, 254, 261, 269
- heating support systems 57, 58, 76
- heat insulation collectors 19
- heat losses 26–7, 80–1, 206, 211–13, 327
- heat meters 59, 60–2, 63
- heat-pipe evacuated tube collectors 20, 32–3
- heat pumps 41, 47, 50
- heat quantity 2–8, 36, 79–81, 89–90, 327
- heat recovery 209, 230–2, 238–9, 259
- heat removal 67
- heat stores
 - advantages/disadvantages 154–6, 163–4, 167–8
 - air-operated solar systems 236–7, 238–9
 - assembly errors 142
 - baffle plates 39
 - buffer stores 40, 69–71, 73, 153–62, 165–8, 170–1
 - bypass circuits 158–9
 - charging/discharging 68–70, 154–5, 157–62, 165–8
 - circulation system integration 156
 - classification 36
 - cold water connection 130–2
 - collector circuits 157–9
 - combination/combined stores 40–5, 73
 - connections 129, 130–2
 - control 156–62
 - cooling systems 265–8, 269
 - dishwashers 46
 - domestic hot water stores 37–40
 - earth reservoirs 179–80
 - energy contents 36
 - energy density 45–6
 - external heat exchangers 163–4
 - heat exchangers 39, 69–70, 71, 73, 158–9, 162–8
 - heat losses 39
 - heat quantity 36
 - heat removal 67
 - hot water extraction 39
 - immersed heat exchangers 158, 162–4
 - installation 128–33
 - insulation 39–40, 128–33
 - large-scale systems 152–62, 165–6, 170–1, 178–80
 - latent heat 42, 44–6
 - Legionella 46–7
 - materials 36
 - narrowness of hot water store 37–8
 - once-through-flow principle 155–6, 161, 166–8
 - principles 36–47
 - pumps 41, 158–9
 - safety 170–1
 - sensible heat 42, 44–6
 - sensors 40
 - solar circuits 40

- solar district heating 178–9
- storage charging 154–5, 157, 159–62, 165–8
- storage materials 36
- storage tank charging 154–5, 159–62, 165–8
- store volumes 37
- stratified systems 38, 73
- system control 156–62
- temperature 36, 40
- thermal stores 40, 69–71, 73, 153–62, 165–8, 170–1
- thermo chemical storage units 42, 44–6
- thermostatic mixing valves 46
- valve controls 46
- washing machines 46
- water heating 69–74, 80–1, 91, 93
- heat times, cooling systems 269
- heat transfer
 - absorbers 17–18
 - commissioning 137–8
 - concentrating systems 186–7, 190–1
 - solar circuits 47, 48–50, 51–2
 - water 48–50
- height angles 9–10
- height safety 108–10, 336
- heliostats 193–4
- hoist transport methods 110
- Holland 46, 315, 316
- Holland *see* Netherlands
- hooks 102, 109, 112
- hot water
 - connections 131–2
 - consumption determination 78–9
 - controllers 57
 - domestic stores 37–40
 - fittings installation 135–6
 - heat requirement 79–81
 - large-scale systems 149–82
 - roofs and roofing 131–2
 - storage operating principles 17–18
 - temperature requirements 150
 - see also* water heating
- house connecting stations 181
- housing construction 235–9
- humidity 257–8, 259, 261
- hybrid air-operated solar systems 228, 234–5
- hybrid collectors 29–30, 228
- hydraulic circuits 208–9
- hydrogen 192
- hygiene issues 153–4
- hypocaust systems 237
- ice formation 140
- immersed heat exchangers 158, 162–4
- inclination
 - collector angles 9–10
 - roofs and roofing 97
- inclined surface transport method 110
- indirect systems 17
- information sources 146–7
- input/output-controllers (IOC) 61–2, 63
- in-roof installation 34, 116–17, 247
- installation 97–136
 - air-operated solar systems 246–8
 - collector field construction 124–6
 - collectors 112–26
 - controllers 57, 136
 - costs 91, 93
 - deliveries 111
 - facades 122–4
 - fittings 110, 118–21, 127, 133–6, 218
 - heat store 128–33
 - in-roof 34, 116–17, 247
 - insulation 127–8, 129
 - materials 103–7, 111
 - on-roof 34, 112–16, 246–7
 - pipes 110–11, 127–8, 129, 135–6
 - roofs and roofing 27–8, 34, 97–126, 246–7
 - safety 107–11, 134
 - secondary circulation 131–2
 - sensors 136
 - solar circuits 106, 126–9, 130, 133–5
 - storage tanks 106, 128–33
 - swimming pool heating 214–19
 - tanks 106, 128–33
- insulation
 - air-conditioning systems 260
 - assembly errors 140, 143
 - collectors 19, 23–4, 30–1
 - damage 140
 - heat stores 39–40, 128–33
 - installation 127–8, 129
 - pipes 47–8, 80–1, 127–8, 129
 - roofs and roofing 34, 103, 104, 121–2
- integral collector systems 29
- interaction with matter, solar radiation 23
- internal heat exchangers 51, 68, 130
- investment 188
- irradiance 2–8, 9–10, 24–5, 26, 254
- irradiation 2–8, 122, 196
- isopleths 257, 258
- Israel 18, 67, 188, 193, 258
- Italy 34, 196, 315, 317
- kinematic viscosity 50
- k*-values, collectors 26–7, 33
- ladders 108–10
- large-scale systems 149–82
 - annuity method 172–4
 - buffer stores 153–62
 - capital-related costs 172–4
 - charging 154–5, 157–62, 165–8
 - collector circuits 157–9, 164–5, 169–70
 - consumption profiles 150, 151
 - consumption-related costs 172, 174
 - contracting 174–7
 - costs 172–7
 - data requirements 149–50
 - dimensioning 152–3
 - district heating 177–82
 - domestic water stores 153–6
 - economic considerations 172–7
 - energy substitution 152
 - external heat exchangers 163–4
 - heat exchangers 158–9, 162–8
 - heat stores 152–62, 165–6, 170–1, 178–80
 - hot water temperature requirements 150
 - immersed heat exchangers 158, 162–4
 - initial data requirements 149–50
 - planning 149–53
 - safety 168–71
 - solar contracting 174–7
 - solar district heating 177–82
 - storage charging principle 154–5, 159–62, 165–8
 - storage tanks 152–5, 159–62, 165–6, 179–80
 - thermal buffer stores 153–62
 - valves 168–71
- latent heat 42, 44–6
- law of communicating pipes 106

- leak testing 137
- Legionella 46–7
- lifting regulations 326
- lifts, roofs and roofing 110
- limescale 51
- limited convection collectors 19
- liquid plastic 101
- liquid sorbents 258–9
- long-term heat storage 178–9
- low-energy houses 238–9
- low-flow systems 68–9
- Luftikuss program 245–6, 278

- MacSolar meter 8
- maintenance 136, 138–9, 143, 188, 219
- man-made greenhouse effect 13
- marketing and promotion 295–328
 - addresses 314–15
 - AIDA 302–4
 - associations 326, 327
 - banner advertising 309
 - benefits 296–7
 - bridge building 318–19
 - brochures 304
 - classified directories 309
 - closed questions 320
 - coffee filter technique 321
 - the company 297–8, 305–6
 - competitors 298–9
 - contact forms 306
 - cooperation 317
 - costs 307–8
 - coverage 301–4
 - customer orientation 295, 321
 - customer relationships 310–15
 - databases 314–15
 - direct marketing 301–4
 - directories 309
 - discussions 317–24
 - echo technique 323
 - email 306
 - European networks 315–17
 - evaluation 315
 - events 304–5
 - experience 300
 - financial support 324–5
 - four pillars concept 297–301
 - fundamentals 295–6
 - funding 325–7
 - government information sources 325, 326, 327
 - homepage 305–310, 314
 - iceberg principle 295–6, 301, 318–20, 322
 - implementation costs 308
 - information sources 325
 - inner attitude 318–19
 - Internet 305–310, 316
 - mailshots 302–4
 - marketing concept 297–301
 - marketing cycles 311–15
 - marketing options 301–14
 - marketing tools 300–1
 - media 305
 - need establishment 320–1
 - objection handling 322–3
 - objectives 287–8, 302
 - open questions 310–11
 - organizations 316, 317
 - personal contact 301–2, 317–24
 - planning 313
 - portals 308–9, 314
 - presentation 321–2
 - press 305
 - price considerations 323–4
 - the product 298
 - product suitability 309–10
 - publications 304, 315–16
 - public media 305
 - pull concept 306
 - push concept 306
 - questioning techniques 320–1
 - R&D 327
 - realization 314
 - resources 300
 - result achievement 322
 - rucksack technique 321
 - sales discussions 317–24
 - sales documents 304
 - search engines 308
 - servicing costs 308
 - 7C strategy 300–1, 312–14
 - simulation programs 287–8
 - SMART technique 312
 - Soltherm Europe Initiative 315–17
 - subsidies 324–8
 - success measurement 307
 - surveys 287–8
 - systematic marketing 296–315
 - target groups 299–301
 - technical costs 310
 - telephone contact 301–2
 - transition phase 322
 - turnover 300–1
 - watering can principle 299–300
 - websites 305–310
- matched-flow systems 68–9
- materials
 - absorbers 202, 203
 - air-operated solar systems 225
 - heat stores 36
 - installation 103–7, 111
 - material-specific variables 338
 - roofs and roofing 103–7, 111
 - swimming pool heating 202, 203
- matrix collectors 224, 225
- measuring solar radiation 8, 65
- mechanical fixings, absorbers 214–16
- membrane expansion vessels (MEV) 55, 87–9, 134
- memory springs 33
- metal roofs and roofing 100, 101
- METEONORM program 290–1
- meteorological bases 1–8
- methane 13
- MEV see membrane expansion vessels
- Mie scattering 4–5
- mixing valves 135
- mobile aluminium access towers 108
- mountings 103–5, 117–22, 215
- multi-function controllers 58
- municipal pool heating 208–10, 212–13, 220–2
- mutual shading 122

- nail plate trusses 99
- natural gas reserves 12
- natural greenhouse effect 13
- The Netherlands 46, 315, 316
- networks, district heating 180–1
- nitrous oxides, climate change 13
- nocturnal cooling 206

- non-insulated pipe heat losses 80–1
- non-renewable energy sources 15
- normalised solar heat costs 94–5
- Northern Europe 17, 67, 77
 - see also individual countries*
- office buildings 240–1
- oil lifetimes 12
- once-through-flow principle 73, 155–6, 161, 166–8
- on-roof installation 34, 112–16, 246–7
- open systems, water heating 67
- open volumetric receivers 193–4
- operating principles
 - absorbers 17–18
 - collectors 18–35
 - controllers 17–18, 55–66
 - glazed flat-plate collectors 24–7
 - heat stores 36–47
 - solar circuits 17, 47–55
 - swimming pool heating 219
- operation-related costs 172, 174, 188
- optical efficiency 26–7, 33, 337
- organic roofs and roofing 101
- organization 143
- orientation issues 8–10, 90
- overheating protection 49, 65–6

- paired sensors 64
- pantiles 99
- parabolic trough collectors 185, 188, 189–93
- parallel connections 125–6
- peak loads 270–1
- pellet-burners 42, 45
- PE pipes 140–1
- performance issues 90–4, 225–6
- personal safety equipment 108–10
- photographic methods 10
- photo-thermal hybrid collectors 29–30
- photovoltaics (PV)
 - air hybrid collectors 29
 - air-operated solar systems 227–8, 233–4
 - radiation measurements 65
- pipes
 - air-operated solar systems 230, 248
 - connections 110–11
 - dimensions 82–4, 86
 - fixings 111
 - heat losses 80–1
 - hot water fittings 135–6
 - installation 110–11, 127–8, 129, 135–6
 - insulation 47–8, 80–1, 127–8, 129
 - PE pipes 140–1
 - pressure losses 83–4
 - roofs and roofing 110–11
 - size determinations 83–4
 - solar circuits 47–8, 82–4, 86
 - swimming pool heating 201–3, 217–19
- pitched roofs 97, 103, 112–17, 216–17, 246
- plain tube heat exchangers 51, 130
- planning
 - air-operated solar systems 242–6
 - cooling systems 259–62
 - large-scale systems 149–53
 - simulation programs 275–293
 - swimming pool heating 211–14
 - water heating 74–90
- plastic sheeting 100, 101
- plate heat exchangers 51, 52
- Polysun program 279–80
- positioning errors 141–2
- Potsdam, Germany 249–50
- power plants 189–95
- press fittings 110, 127
- pressure
 - drops 143–4
 - factor 88
 - gauges 135
 - losses 83–7, 201, 211, 213–14
 - nomenclature 328
 - vessel regulations 170
- prices 90–4, 152, 261, 264
- primary energy savings 271–3
- private pool heating 206–8, 211–12, 220
- process heat 184–8
- process monitoring controllers 59
- promotion *see* marketing and promotion
- propylene glycol 48–50, 141
- protecting against corrosion 48, 106–7, 138–9
- PT100, PT1000 temperature sensors 64–5
- public pool heating 208–10, 212–13, 220–2
- pull concept 306
- pumps
 - circuit pumps 207–8
 - circulating pumps 82–3, 85–7, 134
 - commissioning 138
 - fault detection/rectification 144, 145
 - heat stores 41, 158–9
 - solar circuits 47, 50, 134
 - swimming pool heating 202–3, 207–8, 214
 - taco-setters 145
- purlins 98
- push concept 306
- PV *see* photovoltaics
- pyranometers 8

- quotations 74–6, 93

- radiation
 - matter interactions 23
 - measurements 8, 65
 - nomenclature 337
 - sensors 159
 - solar irradiance 2–8, 9–10
 - see also* solar radiation
- rafters 98, 99
- rapid air bleeders 52–4
- Rayleigh scattering 4–5
- recovery heat coefficients 230
- recovery-solar boxes 231–2
- reference areas 21
- reference values 268
- reflection/reflectors 4–5, 23, 183–4
- refrigerant cooling systems 253–4, 255–6
- regulations 107–8, 170–1, 335–6
- regulators 233
- remote displays 59
- RESOL monitors 61–2, 63
- RETScreen program 280–1
- return-flow prevention 52, 53, 134
- return temperatures 90
- reverse flow filter water 209
- roofs and roofing
 - absorber installation 216–17
 - access safety 108–10
 - air-operated solar systems 227, 246–8
 - anchoring 118–21
 - bonding methods 107
 - chimneys 121
 - clamps 127, 222

- cold roofs 103, 104
- cold water connection 130–2
- collar beams 98
- collector field construction 124–6
- collector installation 112–26
- components 98–103
- convection brakes 132, 133
- cooling systems 261
- corrosion 106–7
- counterweights 117
- coverings 98–103, 113–14
- delivery correctness/completeness 111
- equipment 108–11
- expansion coefficients 105
- flat roofs 34, 97–8, 101, 103–4, 117–22, 246–7
- guy ropes 117
- health and safety 107–8
- heat store 128–33
- height safety 108–10
- hooks 102, 109, 112
- inclination 97
- in-roof installation 34, 116–17, 247
- installation 27–8, 34, 97–126, 246–7
- insulation 34, 103, 104, 121–2
- ladders 108–10
- materials 103–7, 111
- mountings 103–5, 117–22
- mutual shading 122
- on-roof installation 34, 112–16, 246–7
- personal safety equipment 108–10
- pipe installation 110–11
- pitched roofs 97, 103, 112–17, 216–17, 246
- press fittings 110, 127
- purlins 98
- purpose of 97, 98
- rafters 98, 99
- safety 107–11
- scaffolding 108, 109
- seals 98–103, 111
- shading 122
- sheet metal work 111
- site preparation 111–12
- skins 98–103
- standards 335–6
- steep roofs 97
- stools 109
- thermal expansion 105
- thermal insulation 103, 104, 121–2
- tiles 100, 101, 102, 113–14, 116–17
- transport damage 111
- transport techniques 110
- trusses 98, 99
- UK regulations/standards 107–8, 335–6
- United Kingdom standards 335–6
- working safety 108–10
- room heating support 210–11
- Rotex combination storage systems 42, 43
- safety
 - buffer stores 170–1
 - collector circuits 169–70
 - collector field 168–9
 - equipment/devices 47, 52–5
 - expansion vessels 171
 - fences 109
 - heat stores 170–1
 - installation 107–11, 134
 - large-scale systems 168–71
 - regulations 336
 - roofs and roofing 107–11
 - temperature limits 170
 - valves 47, 54–5, 87–9, 134, 168–71, 205–7
- salt solutions 259
- scaffolding 108, 109
- scattering 4–5
- screwed pipe connections 111
- seals 24, 98–103, 111
- secondary circulation 131–2
- SEGS *see* solar electric generation systems
- sensible heat 42, 44–6
- sensors
 - collector circuit control 159
 - housing 65
 - positioning 141–2, 233
 - roofs and roofing 136
 - swimming pool heating 205–6
 - temperature sensors 40, 60, 62–5, 159, 205–6
- series connections 125–6
- servicing 139–46
- shading
 - collectors 122
 - cooling systems 260, 264
 - roofs and roofing 122
 - simulation programs 289
 - solar radiation 10–11
- sheeting 100, 101
- sheet metal work 111
- shielding angles 122
- shingles 99
- short-term heat stores 178
- shut-off fittings 135
- simulation programs 275–293
 - f*-charts 277–278
 - GetSolar program 283–284
 - METEONORM program 290–1
 - planning 275
 - Polysun program 282–3
 - RETScreen program 278–9
 - selection 276–7
 - shading 10–11, 284–8
 - simulation systems 284–8
 - SUNDI program 293
 - swimming pool heating 211–14
 - T*SOL program 279–82
 - time-step analysis 279–84
 - tools and help programs 292–3
 - TRNSYS program 284–5
 - water heating dimensioning 89, 90, 214
 - yields 275
- single-family house systems *see* domestic water heating systems
- single-pass systems 68–9
- single-source heating 212–13
- site preparation 111–12
- site regulations 336
- size determinations 81–3
- skins 98–103
- sky conditions/state 4–5
- skylights 28–30
- slates 101
- small-scale systems 67–95
- snowguards 103
- solar air systems *see* air-operated solar systems
- solar altitude 9–11
- solar-assisted cooling systems 262–3
- solar azimuth 4–5, 9–11
- solar balance 92–4
- solar boxes 231–2
- solar circuits
 - air bleeders 52–4

- air separators 135
- assembly errors 142
- check valves 134
- commissioning 136–7
- connection 130
- corrosion 48, 106, 138
- dirt filters 135
- display instruments 135
- equipment 47, 52–5
- expansion vessels 47, 55, 134
- fittings 47, 133–5
- flow meters 54
- flushing out 136–7
- heat exchangers 47, 51–2, 130
- heat stores 40
- heat transfer 47, 48–50, 51–2
- installation 106, 126–9, 130, 133–5
- maintenance 136
- membrane expansion vessels 55, 134
- operating principles 17, 47–55
- pipes 47–8, 82–4, 86
- pressure losses 83–7
- pumps 47, 50, 134
- rapid air bleeders 52–4
- return-flow prevention 52, 53, 134
- safety equipment/devices 47, 52–5, 134
- shut-off fittings 135
- solar liquid 47, 48–50
- solar stations 55
- swimming pool heating 208–9, 218–19
- valves 47, 54–5, 134
- vents 134–5
- volumetric flow 83–4
- water heating 82–7, 91, 93
- solar concentrating systems 183–96
 - closed volumetric receivers 194–5
 - collectors 184–93
 - costs 188, 196
 - direct irradiation 196
 - dish/Stirling systems 195–6
 - economic considerations 188, 196
 - electricity generation 189–96
 - evacuated tube collectors 185, 186, 188
 - flat-plate collectors 185, 186, 188
 - Fresnel principle 190–1
 - glazed flat-plate collectors 185, 186, 188
 - heat transfer fluids 186–7
 - heliostats 193–4
 - irradiation 196
 - open volumetric receivers 193–4
 - parabolic trough collectors 185, 188, 189–93
 - power plants 189–95
 - process heat 184–8
 - reflectors 183–4
 - solar tower plants 193–5
 - Stirling systems 195–6
 - system integration 186–8
 - tracking devices 185
 - vacuum tube collectors 185, 186, 188
 - volumetric receivers 193–5
- solar constant 1
- solar contracting 174–7
- solar cooling *see* cooling systems
- solar district heating 177–82
 - aquifer storage system 180
 - components 179–81
 - design 179
 - heat stores 178–9
 - house connecting stations 181
 - long-term heat storage 178–9
 - networks 180–1
 - practical experience 181–2
 - short-term heat stores 178
 - storage tanks 179–80
- solar drying 239–40
- solar electric generation systems (SEGS) 189–90
- solar energy
 - charging 68–9
 - feed 67
 - solar radiation 1
- solar fraction 73, 77–8, 89, 90, 94, 272–3
- solar irradiance 2–8, 9–10, 254
- solar liquids 47, 48–50, 137–8, 265–6
- solar pumps 47, 50, 134
- solar radiation 1–11
 - absorption 4–5, 23
 - air mass factor 4–5
 - angle of inclination 8–10
 - astronomical bases 1–8
 - atmospheric absorption 4–5
 - atmospheric reflection 4
 - azimuth angles 4–5, 9–11
 - cleaning requirements 10–11
 - cloud cover 4–5
 - collector inclination angles 9–10
 - concentration 183–4
 - diffuse radiation 2, 3, 6
 - direct radiation 2, 3, 6
 - dust 10–11
 - elevation angles 4–5, 10–11
 - global solar irradiance 2, 3, 5–7, 9
 - heat quantity 2–8
 - height angles 9–10
 - irradiance 2–8, 9–10
 - matter interactions 23
 - measurements 8, 65
 - meteorological bases 1–8
 - orientation 8–10
 - power 2–8
 - reflection 4–5
 - scattering 4–5
 - shading 10–11
 - simulation programs 275–293
 - sky conditions/state 4–5
 - solar altitude 9–11
 - solar azimuth 4–5, 9–11
 - solar constant 1
 - solar energy 1
 - solar irradiance 2–8, 9–10
 - spectrum air mass factor 4–5
 - surface inclination angles 9–10
 - tilt angles 8–10
- solar stations 55
- solar store 91
- solar tower plants 193–5
- Solarwall system 229, 247–8, 250–1
- solar yield 275
- soldering 110, 126–7
- solid sorbents 257–9
- Soltherm Europe Initiative 315–17
- Soltherm Europe Market Reports* 90
- SolvisMax 40–1, 43
- sorbents 257–9
- Southern Europe 67, 122, 186, 253
- space heating 72–4
- Spain 189, 192–6, 315, 317
- specifications lists 92
- specific heat capacity 223
- spectral-selective coatings 22

- spectrum air mass factor 4–5
- stagnation temperatures 35, 83
- standard air collectors 224, 225, 226–7
- standard flat collectors 19
- standards 47, 54, 65, 335–6
- steam generation/generators 35, 192
- steam laws and regulation 170–1
- steel scaffolding 108
- Stefan–Boltzmann law 23, 339
- steps 102
- Stern, Nicholas 14, 15
- Stirling systems 195–6
- stools 109
- storage charging 154–5, 157, 159–62, 165–8, 210
- storage materials 36
- storage tanks
 - approximation formula 152–3
 - assembly errors 142
 - charging 154–5, 157, 159–62, 165–8, 210
 - cooling 146, 265–8, 269
 - corrosion 106, 139
 - fault detection/rectification 145, 146
 - large-scale systems 152–5, 159–62, 165–6, 179–80
 - loading 160–1
 - maintenance 136
 - roofs and roofing 106, 128–33
 - solar district heating 179–80
 - temperature 145, 159–60
- store-in-store systems 73
- stratified systems
 - charging 68–9, 160–1
 - operating principles 17–18
 - water heating 71, 73, 74
- sulphur dioxide 13
- SUNDI program 293
- sunshine duration 5
- sunshine recorders 8
- surface areas 328–9
 - absorbers 78, 211–14
 - collectors 18, 20–1, 81–3, 152–3, 242–3, 270–1
- surface inclination angles 9–10
- SWIFT program 246
- swimming pool heating 197–222
 - absorbers 197–201, 207–9, 211–17
 - approximation formula 211–14
 - auxiliary heating 208, 209–10
 - circuit pumps 207–8
 - collection pipes 217–18
 - combined with other systems 210–11
 - components 197–206
 - connections 209, 213
 - controllers 204–6
 - cooling 206
 - corrosion 106
 - costs 219–20
 - coverings 206
 - dimensioning 211–14
 - distribution pipes 217–18
 - domestic water heating 210–11
 - dual-source heating 213
 - examples 220–2
 - flat absorbers 198–200
 - header pipes 201–3
 - heat exchangers 203–4
 - heat loss 206
 - heat recovery 209
 - hydraulic circuits 208–9
 - installation 214–19
 - maintenance 219
 - materials 202, 203
 - municipal pool heating 208–10, 212–13, 220–2
 - nocturnal cooling 206
 - operation 219
 - pipng 201–3, 217–19
 - planning 211–14
 - pressure loss 201, 211, 213–14
 - private pool heating 206–8, 211–12, 220
 - public pool heating 208–10, 212–13, 220–2
 - pumps 202–3, 207–8, 214
 - quotation preparation 76
 - reverse flow filter water 209
 - room heating support 210–11
 - safety valves 205, 206–7
 - sensors 205–6
 - simulation programs 211–14
 - single-source heating 212–13
 - solar circuits 208–9, 218–19
 - storage tank charging 210
 - systems 206–11
 - temperature 197, 204–6, 207
 - three-way valves 206–7
 - tube absorbers 198–200
 - valves 205, 206–7
 - visitor behaviour considerations 213, 222
 - volumetric flow 211, 213–14
 - yields 198, 199, 219–20
- Sydney tube collectors 20, 32
- systematic marketing 296–315
- system control 156–62
- system efficiency 78, 338
- system integration 186–8
- system parameter monitoring 139
- system pressure drops 143–4
- system variable nomenclature 339
- T*SOL program 279–82
- taco-setters 54, 145
- tank installation 128–33
- tank-in-tank stores 71
- taps 134, 135
- temperature
 - air-operated solar systems 233–4
 - collectors 145
 - cooling systems 257–8, 261
 - difference 59, 145, 204, 207, 233–4
 - fault detection/rectification 145
 - heat stores 36, 156
 - nomenclature 337
 - operating principles 17
 - sensors 40, 60, 62–5, 159, 205–6
 - storage tanks 145, 159–60
 - swimming pool heating 197, 204–6, 207, 212–13
 - water heating 90
- tension belts 215–16
- testing for leaks 137
- thatched roofs and roofing 101
- thermal capacity 48
- thermal conductivity 48, 223
- thermal disinfection 153–4
- thermal expansion 105
- thermal insulation 103–4, 121–2, 127–9, 140, 143, 260
- thermal losses 26–7, 80–1, 206, 211–13, 337
- thermally driven processes 255–9, 263–4
- thermal stores 40
 - chemical storage 42, 44–6
 - circuit discharging 161–2, 165–8

- heat exchangers 69–70, 71, 73
- large-scale systems 153–62
- safety 170–1
- thermistors 64
- thermo chemical storage units 42, 44–6
- thermometers 135
- thermostatic mixing valves 46, 135
- thermosyphon systems 18, 67
- three-way valves 158, 206–7
- Tichelmann connections 125, 209, 213
- tiles 100, 101, 102, 113–14, 116–17
- tilt angles 8–10
- time-step analysis 279–84
- tracking devices 185
- transmission 23
- transparent heat insulation collectors 19
- transpired air collectors 229
- transport damage 111
- transport techniques 110
- TRNSAIR program 246
- TRNSYS program 284–5
- trusses 98, 99
- tube absorbers 198–200
- tubular heat exchangers 51, 52, 130
- twin-store systems 73–4

- UK *see* United Kingdom
- unglazed collectors 19, 21
- United Kingdom (UK)
 - domestic systems 79, 89
 - heat stores 36–7
 - information sources 325–6
 - marketing and promotion 315, 316, 325–6
 - regulations 107–8, 335–6
 - roofs and roofing 109
 - safety regulations 107–8
 - solar radiation 5, 6
 - standards 107–8, 335–6
 - system components 33
- United States of America (USA)
 - concentrating systems 188, 189, 192–3, 195, 196
 - information sources 146, 326–7
 - marketing and promotion 325, 326–7
 - simulation programs 281–2
 - solar radiation 6, 7
 - system components 17, 37

- vacuum collectors 19, 20, 30–5, 50, 185, 186, 188
- valves
 - blending 46
 - controls 46
 - draining 131
 - mixing valves 46, 135
 - safety 47, 54–5, 87–9, 134, 168–71, 205–7
 - solar circuits 47, 54–5, 134
 - swimming pool heating 205, 206–7
 - three-way valves 158, 206–7
- vapour escape pipes 102
- ventilation 234–41, 260–1
- vents 134–5
- viscosity 48, 50
- visual inspections 136
- voltage protection 91, 93, 179–80
- volumetric flow 83–4, 211, 213–14, 244–5, 338
- volumetric receivers 193–5

- walk-on gratings, roofs and roofing 102
- warm roofs 103, 104, 121–2
- washing machines 46

- water
 - heat transfer 48–50
 - propylene glycol mixtures 48–50
- water heating systems
 - air-operated solar systems 233, 237–9
 - auxiliary heating 67, 69, 93
 - buffer stores 69–70, 71, 73
 - charging/discharging stores 68–70
 - circulating pumps 82–3, 85–7, 134
 - circulation lines 80–1
 - closed systems 67
 - collector surface area 81–2, 83
 - combined store systems 73
 - commissioning 91, 93
 - connection installations 91, 93
 - consumption determination 78–9
 - controllers 91, 93
 - costs 90–5
 - dimensioning 74–90
 - dishwashers 46–7
 - drainback systems 67, 72
 - efficiency 78, 94
 - energy balance 92–4
 - error signals 63–4
 - expansion vessels 82–3, 87–9
 - external heat exchangers 68, 71
 - filled systems 67
 - fittings installation 135–6
 - flow-through principle 71
 - forced circulation systems 67
 - heat exchangers 68, 69–70, 71
 - heat losses 80–1
 - heat removal 67
 - heat requirement 79–81, 89–90
 - heat stores 69–74, 80–1, 91, 93
 - individual component calculations 83–9
 - installation costs 91, 93
 - internal heat exchangers 68
 - large-scale systems 149–82
 - Legionella 46–7
 - low-flow systems 68–9
 - matched-flow systems 68–9
 - normalised solar heat costs 94–5
 - once-through flow 73, 155–6, 161, 166–8
 - open systems 67
 - operating principles 17–18
 - performance 90–4
 - planning and dimensioning 74–90
 - pressure losses 83–7
 - prices 90–4
 - quotations 74–6, 93
 - safety valves 47, 54–5, 87–9, 134, 168–71, 205–7
 - single-family house systems 67–95
 - single-pass (low-flow) systems 68–9
 - size determinations 81–3
 - small-scale systems 67–95
 - solar circuits 82–7, 91, 93
 - solar fraction 73, 77–8, 89, 90, 94
 - space heating 72–4
 - specifications lists 92
 - stagnation temperatures 83
 - standard system 70–1
 - store-in-store systems 73
 - stratified stores 71, 73, 74
 - system efficiency 78
 - tank-in-tank stores 71
 - temperature calculations 90
 - thermal losses 80–1
 - thermosyphon systems 67

- twin-store systems 73–4
- valves 47, 54–5, 87–9, 134, 168–71, 205–7
- washing machines 46–7
- yields 92–4, 198–9, 219–20
 - see also* hot water; swimming pool heating
- watering can principle 299–300
- websites 305–310
- welded sheeting 100, 101
- wet connections 33
- wind speed 198, 199
- wine cellar cooling systems 273
- wood holders 103
- working at heights safety 108–10
- Xenon combination storage systems 41, 43
- yields 21, 185–6
 - air-operated systems 248–9
 - controllers 59–63
 - simulation programs 275–293
 - swimming pool heating 198–9, 219–20
 - water heating 92–4, 198–9, 219–20
- Z-connections 125, 209, 213

