

[bookboon.com](http://bookboon.com)

# A First Course in Fluid Mechanics for Engineers

Buddhi N. Hewakandamby



Download free books at

[bookboon.com](http://bookboon.com)

Buddhi N. Hewakandamby

# A first course in Fluid Mechanics for Engineers

---

A first course in Fluid Mechanics for Engineers  
© 2012 Buddhi N. Hewakandamby & Ventus Publishing ApS  
ISBN 978-87-403-0069-7

# Contents

	<b>A Word ...</b>	<b>8</b>
<b>1</b>	<b>Physics of Fluids</b>	<b>9</b>
	Introduction	9
1.1	Nature of fluids	9
1.2	Fluid as a continuum	10
1.3	Properties of fluids	11
1.4	Fluid Mechanics	21
	References	22
<b>2</b>	<b>Fluid Statics</b>	<b>23</b>
	Introduction	23
2.1	Pressure	23
2.2	Pressure at a point	24
2.3	Pressure variation in a static fluid	26
2.4	Pressure and head	29
2.6	Use of hydraulic pressure	35



2.7	Buoyancy	36
2.8	Force on immersed plates	38
	References	45
<b>3</b>	<b>Dimensional analysis</b>	<b>46</b>
	Introduction	46
3.1	Dimensional homogeneity	47
3.3	Buckingham' Pi theorem	48
3.2	Uses of dimensional analysis	53
<b>4</b>	<b>Basics of Fluid Flow</b>	<b>54</b>
	Introduction	54
4.1	Velocity field	55
4.2	Control volume and system representation	58
4.3	Continuity of flow	60
4.4	Types of flow	63
4.5	Bernoulli equation	64
4.6	Physical meaning of the Bernoulli equation	66
4.7	Applications of Bernoulli equation	67
4.8	Linear Momentum	81
	References	87

<b>5</b>	<b>Laminar and Turbulent Flow</b>	<b>88</b>
	Introduction	88
5.1	Laminar Flow	90
5.2	Turbulent flows	96
	References	102
<b>6</b>	<b>Viscous Flow in Pipes</b>	<b>103</b>
	Introduction	103
6.1	Laminar flow in a circular pipe	103
6.2	Turbulent flow in a pipe	107
6.3	Bernoulli Equation revisited	109
6.4	Losses in pipes	112
6.5	Other head losses in pipes	117
	References	119
<b>7</b>	<b>Pumping of liquids</b>	<b>120</b>
	Introduction	120
7.1	Pump classification	121
7.2	Centrifugal pumps	123
7.3	Bernoulli's equation and system head	127
7.4	System curve	133

7.5	Net Positive Suction Head (NPSH)	136
7.6	Flow Control	138
7.7	Some remarks on practical issues	142
	References	143

# A Word ...

When students start an undergraduate course in engineering, they experience a step change in the level of complexity of the materials that had to be learned. Fluid Mechanics is one such module taught in the first year of the engineering undergraduate courses. It is a core module for Chemical, Mechanical and Civil engineers. The concepts may seem difficult and hard to grasp at the first instance but as the knowledge broadens, one may find it fascinating. This book is a collection of lecture notes developed from a series of lectures delivered to first year Chemical Engineers.

The target readership is the first year engineering undergraduates but it could be used by anybody who wants to find the joy in learning fluid mechanics.

Some of the figures in this document are taken from the World Wide Web.

-B

# 1 Physics of Fluids

## Introduction

Transport phenomena are one of the cornerstones *Chemical Engineering* is built upon. The three components that comes under transport phenomena are

1. Heat transfer
2. Mass transfer
3. Momentum transfer.

Other than conduction and diffusion in solid materials, both heat and mass transfer are influenced by the motion of the medium. In most chemical engineering applications the heat and mass transfer involve fluids. For example, reactors are continuously stirred to induce flow to improve heat transfer as well as mixing. In a heat exchanger, two fluids flow on either side of tubes transferring heat from the process fluid to a service fluid (in cooling). The task chemical engineers are expected to perform is to design, and operate a process that produces a commercially valuable product from the raw materials. In most cases, they are to ensure process fluids be transported from the storage tanks through the process equipment to the product storage in a controlled manner. For these tasks and many other, chemical engineers *must* have an understanding of Fluid Mechanics.

In this section, we briefly discuss the nature of fluids. Basic concepts such as density, viscosity, surface tension and pressure are introduced and discussed in detail. We will examine the cause of these properties using a description at molecular level and further investigate how they would behave at macroscopic scales.

### 1.1 Nature of fluids

The greatest scientist ever, Sir Isaac Newton, provided a definition for fluids based on the observation. In Book II, Section V of the *Principia* the definition is given as

*“A fluid is any body whose parts yield to any force impressed on it, by yielding, are easily moved among themselves.”*

With a modest change to the above, describing the nature of the force, we still use this simple definition. A fluid can be defined as

*“a substance that deforms continuously under the application of a shear (tangential) stress no matter how small the shear stress may be.”*

From this definition, it is clear that two states of matter, Liquid and gas, are fluids. Even though solids yield under shear stress, the deformation it undergoes is finite and once the force is released, unlike fluids, it tends to assume its initial shape.

## 1.2 Fluid as a continuum

Fluids, like any other substance, are made of molecules. Weak cohesive forces keep molecules attracted to each other. However, the molecules are in constant motion. Distance a molecule travel before hitting another is called the mean free path  $\lambda$ . This mean free path is directly proportional to the temperature and inversely proportional to the pressure.

If we look at a liquid at microscopic length scale, we would be able to see molecules of the liquid moving in the space bouncing off each other and the container wall. At this length scale, fluids are discontinuous spatially. However, we very seldom work at this length scale when handling fluids. At a larger length scale, for instance when we consider a tiny liquid droplet of about 1 mm radius, it appears as a continuous phase. In this example, the diameter of the droplet is called the characteristic length: the length scale at which we observe the droplet. Assume the characteristic length scale to be  $L$ . The ratio between the mean free path and the characteristic length gives a nondimensional quantity called Knudsen number.

$$Kn = \frac{\lambda}{L} \quad (1.1)$$

Knudsen number gives a feeling about the continuity of a fluid at the length scale of observation.

$Kn \leq 0.001 \Rightarrow L \geq 1000\lambda$ , fluid can be considered as a continuum.

$0.001 \leq Kn \leq 0.1 \Rightarrow 100\lambda \leq L \leq 10\lambda$ , rarefaction effects start to influence the properties.

Around  $Kn = 0.1$ , the assumption that a liquid is a continuum starts to break down.

$Kn > 10$  we are looking at molecules at a length scale smaller than their mean free path; the continuum approach breaks down completely.

Figure 1.1 shows the variation of mass to volume ratio of a fluid across several orders of magnitude in length scale. Consider a miniscule volume  $\Delta V$ , say a volume with few angstroms in diameter, that can hold few molecules initially. If we increase this  $\Delta V$  volume in size (across length scales), the number of molecules it can hold increases. Molecules move in and out of this hypothetical volume element constantly. At the molecular length scale, the rate of molecular movement has an effect on the density making the value to fluctuate. However, at a rather large length scale, say around  $Kn = 0.001$ , oscillations start to converge to a constant value. Above this length scale, the fluid can be treated as a continuous medium showing constant bulk properties. It is this approximation that makes us to treat fluids in the way we present in this book.



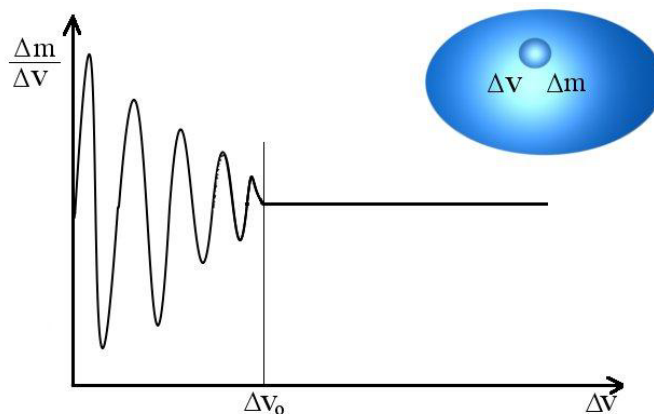

**Figure 1.1** Variation of the ratio  $\Delta m/\Delta V$  against increasing length scale.

### 1.3 Properties of fluids

A bottle would weigh more when filled with water than olive oil. Again, you might have observed that honey flows slower than water. Fluids differ from one another due to the differences of the inherent properties. Important properties to consider when learning mechanics of fluids are

1. Density
2. Viscosity and
3. Surface tension

There are other properties such as boiling point, freezing point that are not considered here.

#### 1.3.1 Density

Density of any substance (i.e. fluids and solids) is defined as the mass of a unit volume of that substance. It is often expressed in  $\text{kg}/\text{m}^3$  and usually designated by the Greek symbol  $\rho$  (rho). Therefore, the density,

$$\rho = \frac{m}{V} \quad (1.2)$$

where  $m$  and  $V$  represent the mass and the volume respectively. On the other hand, the specific volume is the volume per unit mass. It is given by the reciprocal of the density –that is

$$V = \frac{1}{\rho} \quad (1.3)$$

Units of specific volume are  $\text{m}^3/\text{kg}$ .

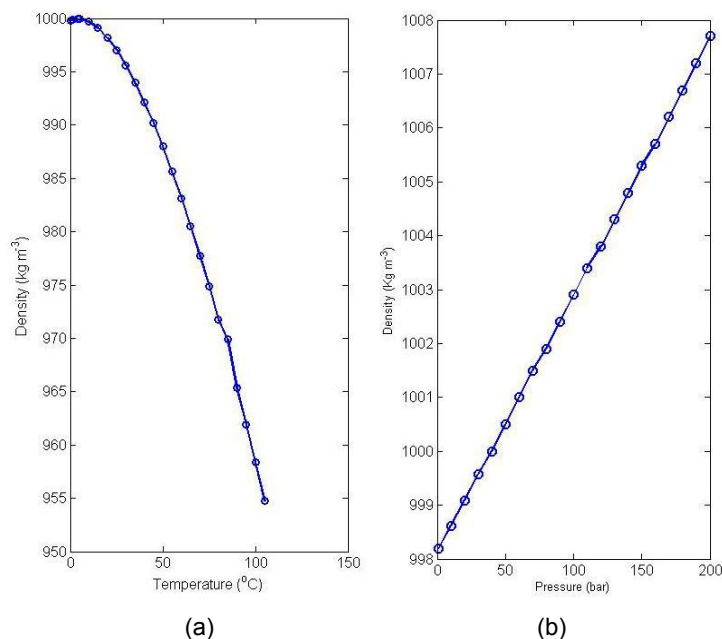

**Figure 1.2.** Variation of density with temperature and pressure

Density varies widely between different fluids. Densities of some common fluids are given in Table 1.1. Usually, density varies with temperature and pressure. Figure 1.2 (a) shows the variation of density of water with temperature at atmospheric pressure. It shows that the density of water decreases with increasing temperature. It should be noted that for water at 1 atm, density increases to a maximum 1000 kg/m<sup>3</sup> at 4 °C before starting to decrease. Figure 1.2 (b) shows the influence of pressure on density at 20 °C. The density increases with increasing pressure. Since the compressibility (a concept discussed in section 1.3.4) of water is very small, the density variation is small for a wide range of pressures. It can be seen from Figure 1.2 (b) that the density increased only by 1% over 200 fold increase in pressure. Therefore variation of density with press is often assumed negligible for liquids. For gases however, this variation is considerably large as the compressibility of gasses is rather high.

The reason for increase of the density with increasing pressure is the compressibility of fluids. Neglecting this leads to the assumption that the liquids are *incompressible* –which is not far from the truth. For engineering calculations this assumption works well providing realistic solutions.

Specific gravity, usually denoted by SG, is a concept associated with density. Specific gravity of a substance gives the density of that substance relative to the density of water.

$$SG = \left[ \frac{\rho}{\rho_{water}} \right]_{T=4^{\circ}\text{C}} \quad (1.4)$$

Density of liquids is measured using gravity bottles.

Fluid	Density/(Kg m <sup>-3</sup> )	Viscosity/(Pa s)
<b>Gases</b>		
Air	1.205	1.8×10 <sup>-5</sup>
Ammonia	0.717	9.8×10 <sup>-6</sup>
Carbon dioxide	1.842	1.4×10 <sup>-5</sup>
Chlorine	2.994	1.29×10 <sup>-5</sup>
Oxygen	1.331	1.92×10 <sup>-5</sup>
<b>Liquids</b>		
Water	998	0.001
Olive oil	800	0.081
Castor oil	955	0.985
Glycerol	1260	1.495
Kerosene	820	0.0025

**Table 1.1** Properties of common gases and liquids at 20 C and 1 atm pressure.

### 1.3.2 Viscosity

As already pointed out, different liquids flow at different rates given all other conditions remains same. This means there is some property that affects the way fluids flow. This property is called *viscosity*.

Viscosity of a fluid originates from the nature of molecular interactions. Liquids, unlike gasses, have restricted molecular

Please click the advert

## DESTINATIONS

	GATE	ARRIVAL
INDUSTRY IMPACT	OW	FASTER
GLOBAL ASSIGNMENTS	OW	FASTER
SENIOR CLIENT CONTACT	OW	FASTER
CAREER DEVELOPMENT	OW	FASTER
MAKE PARTNER	OW	FASTER





DISCOVER OUR WORLD

**GET THERE FASTER**

Some people know precisely where they want to go. Others seek the adventure of discovering uncharted territory. Whatever you want your professional journey to be, you'll find what you're looking for at Oliver Wyman.

Discover the world of Oliver Wyman at [oliverwyman.com/careers](https://oliverwyman.com/careers)



motion: more or less a vibration with smaller amplitude than that for gas but higher than that of solids. When liquids flow under applied shear, molecules are in motion and continuously dislocating from its molecular arrangement with respect to other molecules. To dislocate a molecule, a certain amount of energy is required. Viscosity is the energy that needs to dislocate a mole of a fluid<sup>1</sup>.

$$\mu = \frac{\tilde{N}h}{\tilde{V}} e^{(3.8T_b/T)} \quad (1.5)$$

$\mu$  = Viscosity  
 $\tilde{N}$  = Avogadro number  
 $h$  = Plank's constant  
 $\tilde{V}$  = Volume of a mole of liquid  
 $T_b$  = Boiling point of the liquid  
 $T$  = Temperature

Viscosity characterises the flow of fluids. Newton, studying the flow realised that the applied shear force and the amount of deformation relate to one another. For example consider a rectangular fluid packet as shown in figure 1.3. A shear force  $F$  is applied to the upper surface at time  $t=0$ . During a small period of  $\delta t$ , upper surface moves a small distance  $\delta x$  deforming the rectangle to its new position shown in (b).

For the proof and an informative discussion see Bird, R.B., Stewart, W.E. and Lightfoot, E.N., Transport Phenomena, 2 Edition, John Wiley, 2002

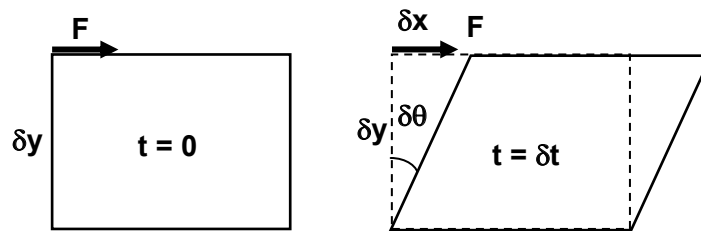

**Figure 1.3.** Deformation of a rectangular fluid element under applied shear stress

As long as the force  $F$  is applied, the fluid element will continue to deform. The rate of deformation is given by the rate at which the angle  $\delta\theta$  changes. The rate of deformation is proportional to the shear stress applied. Shear stress is normally designated by the Greek letter  $\tau$  (tau).

$$\tau = \frac{F}{A} \quad (1.6)$$

The rate of deformation is given by the rate at which the angle  $\delta\theta$  increases with applied shear force  $\tau$ . Considering the proportionality

<sup>1</sup> On the other hand this can be seen as an energy dissipation mechanism. An agitated liquid will eventually come to rest (once the agitation mechanism is removed) due to the dissipation of the energy.

$$\tau \propto \frac{\delta\theta}{\delta t}$$

The angle  $\delta\theta$  is given by

$$\tan\delta\theta = \frac{\delta x}{\delta y}$$

For small angles  $\tan\delta\theta \approx \delta\theta$

Therefore,

$$\tau \propto \frac{\delta x}{\delta y \delta t}$$

Since  $\lim_{\delta t \rightarrow 0} \frac{\delta x}{\delta t} \rightarrow du$ , where  $du$  is the velocity induced by the applied force.

$$\tau \propto \frac{du}{dy}$$

Newton postulated that proportionality constant is the viscosity. This gives

$$\tau = \mu \frac{du}{dy} \tag{1.7}$$

This equation achieves dimensional homogeneity only if  $\mu$  has units Pa s (Pascal seconds). However, it is common practice to give the viscosity in *Poise* (P) or *centipoises* (cP), a unit named after French physicist Jean Marie Poiseuille.

$$1\text{P} = 1 \text{ g cm}^{-1} \text{ s}^{-1}$$

The term  $\frac{du}{dy}$  is called the *velocity gradient*.

Above equation shows that the shear stress is linearly proportional to the velocity gradient. Fluids that show this linear relationship is called *Newtonian fluids*. Water, air, and crude oil are some examples of Newtonian fluids. However, there are fluids that do not show the linear relationship. They are called non-Newtonian fluids. Polymer melts, xanthan gum and resins are some examples for non-Newtonian fluids. In non-Newtonian fluids the viscosity often depends on the shear rate and also the duration of shearing. We will discuss non Newtonian fluids later in the lecture series.

The viscosity  $\mu$  is called the absolute or dynamic viscosity. There is another related measure of viscosity called kinematic viscosity often designated by the Greek letter  $\nu$  (nu).

$$\nu = \frac{\mu}{\rho} \tag{1.8}$$

Kinematic viscosity has the units  $\text{m}^2\text{s}^{-1}$ . Units of kinematic viscosity in cgs system,  $\text{cm}^2\text{s}^{-1}$  is called Stokes. It is so named

in honour of the Irish mathematician and physicist George Gabriel Stokes. Kinematic viscosity could be understood as the area a fluid can cover during a unit period of time under the influence of gravity (during a second).

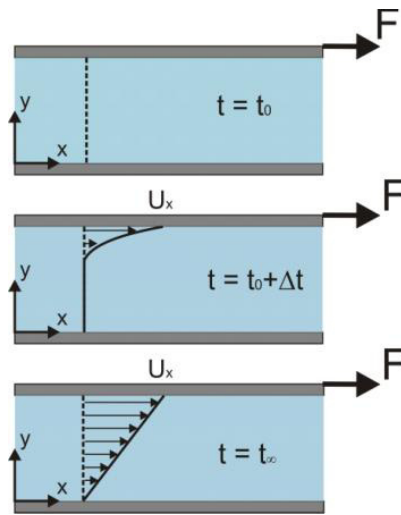

Figure 1.4. Development of velocity over time for a suddenly accelerated plate

As mentioned before, viscosity affects the fluid flow by setting a velocity gradient proportional to the shear stress applied on the fluid. For example consider a fluid trapped between two plates. If one plate, say the top one, is pushed forward at the constant velocity  $U$  while holding the bottom plate stationary all the time, the fluid start to move slowly. With time

Please click the advert

# Day one

## and you're ready

Day one. It's the moment you've been waiting for. When you prove your worth, meet new challenges, and go looking for the next one. It's when your dreams take shape. And your expectations can be exceeded. From the day you join us, we're committed to helping you achieve your potential. So, whether your career lies in assurance, tax, transaction, advisory or core business services, shouldn't your day one be at Ernst & Young?

What's next for your future?

[ey.com/careers](http://ey.com/careers)

© 2010 EYGM Limited. All Rights Reserved.



the velocity will penetrate down to the bottom plate generating a velocity profile along the depth as shown in Figure 1.4. The fluid elements at the top plate are being dragged at the same velocity as the plate. Fluid elements slightly below is dragged along by the first layer. All subsequent layers are dragged by the one above. On the other hand you can view that as the layer below slowing down the one above by offering some friction; hence the energy dissipation.

Viscosity is measured using a wide range of viscometers that measures the time taken to flow a known amount of the liquid or measuring the shear rate indirectly measuring the torque of a shaft rotating in the liquid. Ostwalt, Cannon-Fenske and Saybolt viscometers measures the flow time and cone and plate type viscometers use the torque measurements.

### 1.3.3 Surface Tension

Consider a liquid at rest in an open vessel. The liquid surface is in contact with the air at the room temperature. Consider a molecule of the liquid in the bulk surrounded by other molecules as shown by A in Figure 1.5. As we have discussed in section 1.2, this molecule is attracted to the neighbouring molecules making it to move. If the time averaged distance is considered, the molecule will be in the close vicinity of its initial location as the force exerted by the neighbouring molecules acts on all directions.

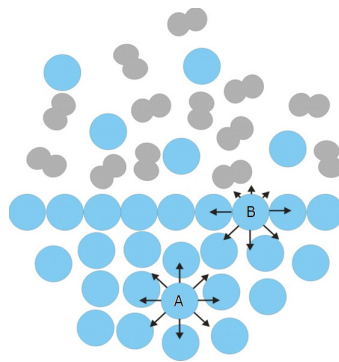
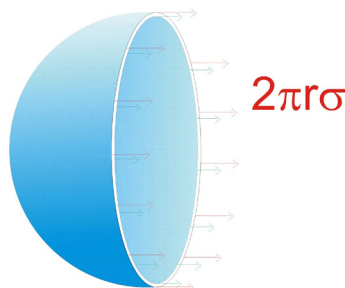

**Figure 1.5.** Intermolecular forces acting on liquid molecules.

Consider a molecule sitting at the air/liquid interface (B in Figure 1.5). It is surrounded by liquid molecules below the interface and liquid vapour molecules in the air above the interface. The liquid molecules, larger in number and in the close vicinity, attract the molecule inward while a weaker attractive force outward. The net force acts into the fluid which makes the molecule to move inwards. However, the adjacent molecules at the surface exert a higher force to keep the molecule in place. This gives the liquid surface a flexible membrane like property which we call the “*surface tension*”. It is defined as the extra amount of energy available per unit area of the surface. This extra energy is the *Gibb’s free energy*. Therefore, the surface tension can be described as the Gibb’s free energy per unit area.

Units of the surface tension are  $\text{J/m}^2$  or  $\text{N/m}$ .

Surface tension can be defined as the force act normal to a meter long hypothetical line drawn on the fluid surface. Surface tension is the reason for capillary rise and capillary depression, soap bubbles, allowing small insects to sit on the liquid surface, etc.



**Figure 1.6.** Forces acting on a soap bubble. To show the forces only one half of the bubble is considered.

Consider a spherical soap bubble with radius  $r$ . It has two surfaces, one inside and the other outside as shown in Figure 1.6. Assume the surface tension of the soap solution is  $\sigma$ . Pressure inside has to be higher than the outside. The force applied on the projected area is  $\Delta p \times \pi r^2$ . This force is balanced by the surface tension. The force exerted by the surface tension is  $2\pi r\sigma$ .

Considering the force balance,

$$\Delta p \times \pi r^2 = 2 \times 2\pi r\sigma$$

$$\Delta p = 4\sigma \left( \frac{1}{r} \right)$$

For a surface with difference curvatures in the two mutually perpendicular directions (like that of an ellipsoid) the above equation can be written as

$$\Delta p = \sigma \left( \frac{1}{r_1} + \frac{1}{r_2} \right) \quad (1.9)$$

This equation is known as the Young-Laplace equation.

Another interesting concept associated with surface tension is the wetting property. A liquid drop, when deposited on a solid substrate, will spread until it reaches the equilibrium. The line at which the liquid, air and the solid substrate meet is known as the contact line. Equilibrium is achieved when the forces acting at the contact line balances each other. A liquid film forming a contact line at equilibrium would form an angle with a surface as shown in Figure 1.7. Angle between the tangent to the liquid surface drawn at the contact point and the substrate on which the liquid is resting *measured through the liquid* is known as the *contact angle*. In Figure 1.7, the contact angle is given as  $\theta$ .

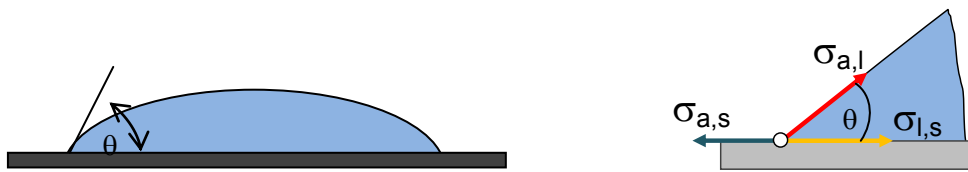

**Figure 1.7.** Contact angle and the forces acting at the contact line of a liquid drop sitting on a horizontal plate.

Figure 1.7 shows the forces acting at the contact line.

$\sigma_{l,a}$  : liquid-air interfacial energy (surface tension)

$\sigma_{l,s}$  : liquid-solid interfacial energy

$\sigma_{s,a}$  : solid-air interfacial energy

Like surface tension the other two are also defined as energies per unit area or forces acting on a unit length of the contact line. The force balance gives

$$\sigma_{a,s} = \sigma_{l,s} + \sigma_{a,l} \cos \theta.$$

Therefore, the contact angle is given by

$$\cos\theta = \frac{\sigma_{a,s} - \sigma_{l,s}}{\sigma_{a,l}} \quad (1.10)$$

When the contact angle  $\theta < \pi/2$ , the liquid is wetting the surface and when  $\theta > \pi/2$ , the liquid does not wet the substrate. Water usually has a small contact angle and mercury has a large contact angles. Figure 8 shows three different wetting conditions. Figure 1.8 (a) shows a water drop on a hydrophobic surface. The droplet does not spread. Instead it forms a large contact angle. Figure 1.8 (b) shows a water droplet on normal glass. Water wets the glass forming a contact angle less than  $\pi/2$ . The last image shows a droplet sitting on a strongly hydrophilic surface.

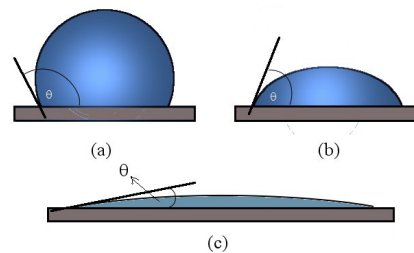

**Figure 1.8.** Contact angles representing three different wetting conditions.

A liquid will spread on any surface until the free energy assumes the minimum possible value. Liquids rise up in capillaries against gravity due to the same reason.

### 1.3.4 Compressibility

Seventeenth century British philosopher/physicist Robert Boyle published his observations on the influence of pressure on a fixed volume of gas in the second edition of his book<sup>2</sup> “*New Experiments Physico-Mechanicall, Touching the Spring of the Air,.....*” published in 1662. He observed that for a fixed amount of an ideal gas maintained at a constant temperature, the volume ( $V$ ) is inversely proportional to the pressure ( $P$ ).

$$V \propto \frac{1}{P}$$

Change of volume in a unit volume per unit change of pressure is defined as the compressibility. If the change of a unit volume is  $\delta v$  for an increase of pressure by a  $\delta p$  amount, the compressibility can be defined as

$$K = \frac{\delta V}{V\delta P} \quad (1.11)$$

$1/K$  is called the bulk modulus and is a measure of resistance to the change of volume under pressure.  $K$  itself is a function of pressure.

2 Boyle, R., 1662, “*New Experiments Physico-Mechanicall, Touching the Spring of the Air and its Effects (Made, for the Most Part, in a New Pneumatical Engine) Written by Way of Letter to the Right Honorable Charles Lord Vicount of Dungarvan, Eldest Son to the Earl of Corke*”. 2nd Ed., Oxford

The decrease in volume at higher pressure results in increasing the density. For gasses where the volume change is significant the change in density becomes considerably large. For fluids, since the molecules are closely packed than that of gasses, the volume change is small. Increase of pressure has very little effect on the volume of solids.

Value of  $K$  for air at STP is  $0.99 \text{ Pa}^{-1}$ . This value for water at STP is  $4.6 \times 10^{-10} \text{ Pa}^{-1}$ . For solids the value of  $K$  is in the order of  $10^{11} \text{ Pa}$ . This means that the relative change of volume is negligibly small for liquids and solids.

### 1.3.5 Other properties of fluids

Boiling point of a liquid at 1 atm is a characteristic property. For example, boiling point of water at 1 atm is  $100^\circ\text{C}$ . Similarly, vapour pressure of a fluid is an important property. This becomes an issue when engineers select centrifugal pumps. However, these properties are not considered in this extensively in this text.

## 1.4 Fluid Mechanics

Fluid mechanics is the discipline where we analyse the behaviour of fluids. Figure 1.9 given below shows a broad classification of fluid mechanics. Under fluid mechanics we learn fluids at rest (hydrostatics) and motion of fluids (dynamics). Dynamics divides into two branches depending on the consideration of the viscosity to describe the flow. Inviscid flow is where the influence of viscosity is neglected. Viscous flow considers the viscosity as a dominant parameter that influences the flow.

Heat, mass and momentum transport together with reaction kinetics forms the core of Chemical Engineering. Most of the chemical engineering problems are about transporting one or more fluids from the start of a process to the end while making them to mix, react and separate. Heat and mass transport in process vessels are greatly influenced by the momentum transport. Fluid mechanics explains the basics of momentum transport. A good understanding of fluid mechanics will be beneficial to all engineers.

This book considers incompressible fluids unless stated otherwise.

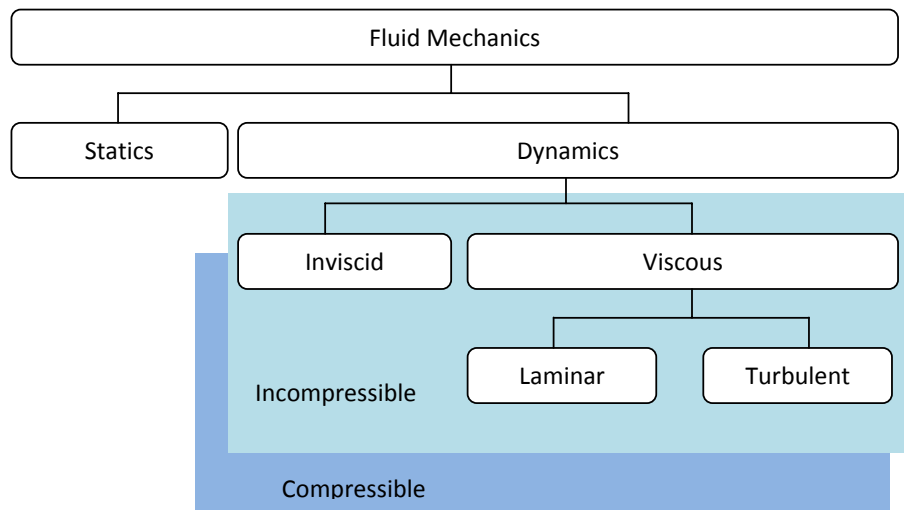

Figure 1.9. A broad classification of fluid mechanics

Please click the advert



Hellmann's is one of Unilever's oldest brands having been popular for over 100 years. If you too share a passion for discovery and innovation we will give you the tools and opportunities to provide you with a challenging career. Are you a great scientist who would like to be at the forefront of scientific innovations and developments? Then you will enjoy a career within Unilever Research & Development. For challenging job opportunities, please visit [www.unilever.com/rdjobs](http://www.unilever.com/rdjobs).

Could it be   
Unilever





## References

- 1) Bird, R.B., Stewart, W.E., and Lightfoot E.N., Transport Phenomena, 2 Ed., John Wiley & Sons, 2002.
- 2) Fay J.A., Introduction to Fluid Mechanics, MIT Press, 1994.
- 3) Fox R.W., McDonald, A.T., Pritchard, P.J., Introduction to Fluid Mechanics, 6th Ed., John Wiley & Sons, 2003.
- 4) Perry, R.H. and Green, D.W., Perry's Chemical Engineers' Handbook, 7th Ed., McGraw-Hill, 1997

Please click the advert



Discover the truth at [www.deloitte.ca/careers](http://www.deloitte.ca/careers)

**Deloitte.**

© Deloitte & Touche LLP and affiliated entities.

Download free ebooks at [bookboon.com](http://bookboon.com)

# 2 Fluid Statics

## Introduction

Statics is the area of fluid mechanics that studies fluids at rest. It also extends to fluids in motion when there is no relative motion between adjacent fluid particles (e.g. rigid body motion). In Chemical engineering context, fluid statics provide an essential body of knowledge to design liquid storage tanks considering forces acting on viewing glasses, sluice gates, required wall thicknesses etc.

Imagine a small fluid element surrounded by the rest of the fluid. The boundary of this fluid particle experience shear stress due to intermolecular forces. The fluid element experiences the gravitational force irrespective to its motion or the position. The force acting on the fluid element due to the gravity is given by the product  $m\mathbf{g}$  where  $m$  and  $\mathbf{g}$  are the mass of the element and the acceleration due to gravity respectively. Such forces appear in fluids due to external fields such as gravity or electromagnetic fields are called the body forces. Body forces acts on the whole volume of the fluid particle: hence the name.

The stresses appearing at the boundary could be divided into two categories; (1) pressure and (2) viscous stresses. The viscous stresses arise due to the relative motion of neighbouring fluid molecules. Viscous stresses on this fluid particle change locally depending on the relative velocity of the surrounding fluid. Therefore, for fluids at rest it is important to understand the role of the pressure.

## 2.1 Pressure

In weather reports, you might have heard of “high pressure” or “low pressure” regions that make clouds to move. This refers to the force air mass above the ground applying on a unit area on the ground.

Pressure is defined as the total force applied normal (perpendicular) to a unit surface area.

$$\text{Pressure} = \frac{\text{Total static force exerted normal to the area}}{\text{Area on which the force is applied}}$$

Consider a force  $F$  applied on an area  $A$  as shown in Figure 2.1.

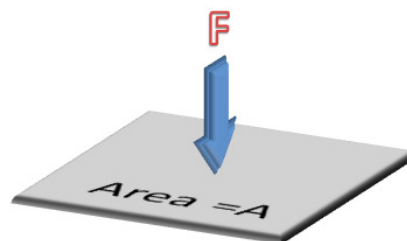

**Figure 2.1.** Definition of pressure. Force  $F$  acting on an area of  $A \text{ m}^2$ .

$$\text{Pressure} = \frac{F}{A} \tag{2.1}$$

Force is a vector. It has a magnitude and a direction of action. Area is a scalar as only a magnitude is needed to define it sufficiently. It should be noted that pressure is a scalar.

Pressure has the units  $\text{N/m}^2$ .  $\text{N/m}^2$  is called a Pascal (P) in honour of *Blaise Pascal*, a French mathematician and a physicist whose work on static fluids lead to understand the concept of pressure. The other most widely used unit is mercury millimetres (Hg mm).

## 2.2 Pressure at a point

As mentioned before, pressure is a scalar. To understand how the pressure act at a point consider a small prism of fluid at equilibrium. Figure 2.2 shows the details of the fluid prism under consideration. Prism is given by the three rectangular faces *ABCD*, *ABFE*, and *CDEF*. The prism is selected such a manner that it has two right triangles *ADE* and *BCF* sealing the prism. Assume the fluid exert different pressures on each face (as shown in the table below).

Face	Pressure
ABFE	PA
ABCD	PB
CDEF	PC

# Grant Thornton—<sup>REALLY</sup> a great place to work.

We're proud to have been recognized as one of Canada's Best Workplaces by the Great Place to Work Institute™ for the last four years. In 2011 Grant Thornton LLP was ranked as the fifth Best Workplace in Canada, for companies with more than 1,000 employees. We are also very proud to be recognized as one of Canada's top 25 Best Workplaces for Women and as one of Canada's Top Campus Employers.



**Priyanka Sawant**  
Manager





Audit • Tax • Advisory  
[www.GrantThornton.ca/Careers](http://www.GrantThornton.ca/Careers)



**Grant Thornton**  
An instinct for growth™

© Grant Thornton LLP. A Canadian Member of Grant Thornton International Ltd

Please click the advert

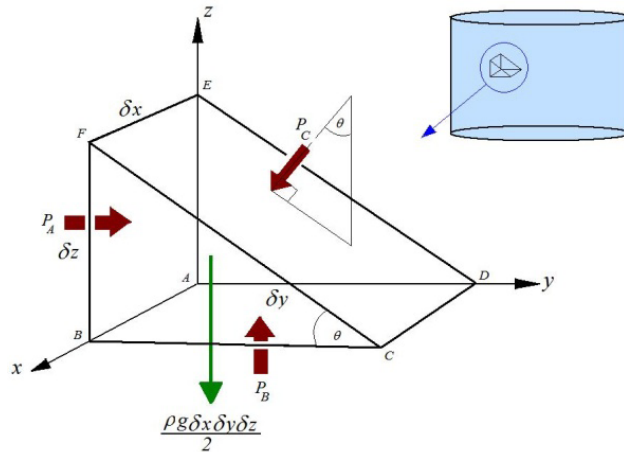

Figure 2.2. Pressure acting on a fluid prism at rest.

The width and the length of the base of the prism are  $\delta x$  and  $\delta y$  respectively. Height of the prism is  $\delta z$ .

We assumed that the fluid is at equilibrium. Therefore, the forces acting on the prism must be at equilibrium.

Considering the force balance in  $y$  direction,

$$P_A \delta x \delta z = P_C \delta x \cdot FC \cdot \sin \theta$$

$$FC \cdot \sin \theta = \delta z$$

Therefore,  $P_A = P_C$  (2.2)

Similarly, the force balance in  $z$  direction gives

$$P_B \delta x \delta y - P_C \delta x FC \cos \theta = \frac{\rho g}{2} \delta x \delta y \delta z$$
(2.3)

where the term on the right hand side gives the weight of the fluid element. Furthermore,

$$FC \cdot \cos \theta = \delta y$$

This allows us to simplify Eq. (2.3).

$$P_B - P_C = \frac{\rho g}{2} \delta z$$
(2.4)

As we are interested about the pressure at a point, assume the element to be shrinking to a minute volume. This is similar to taking the limit  $\delta z \rightarrow 0$ . At that limit, the weight of the element becomes vanishingly small resulting

$$P_B = P_C \tag{2.5}$$

Equations 2.2 and 2.5 show that  $P_A = P_B = P_C$  (2.6)

This leads to the conclusion that *the pressure at a point in a fluid at rest is independent of direction as long as there are no shearing stresses present*. This is called Pascal’s Law.

### 2.3 Pressure variation in a static fluid

Consider a static fluid at equilibrium. Pressure at any arbitrary point is indicated by P. Assume an infinitesimal fluid element with sides  $\delta x$ ,  $\delta y$ , and  $\delta z$  having the arbitrary point at the centre. The weight of the fluid element acts in the direction of gravity only. This is shown in the Figure 2.3.

Pressure at a point  $\delta y$  distance to the right of the initially selected point is  $P + \delta p$ . Therefore, the variation of pressure in  $y$  direction per unit distance can be defined as  $\delta P / \delta y$ . Therefore, pressure at the centre of the surface  $\frac{\delta y}{2}$  distance to the right of the selected point can be written as  $P + \frac{\delta P}{\delta y} \frac{\delta y}{2}$ . Similarly, pressure at a point  $\frac{\delta y}{2}$  to the left of the selected point will be  $P - \frac{\delta P}{\delta y} \frac{\delta y}{2}$ . The sign convention assumed that the pressure increases in the positive directions of the Cartesian coordinates. Figure 2.3 shows the pressures at the surfaces of the fluid element (values for the x-direction is not shown).

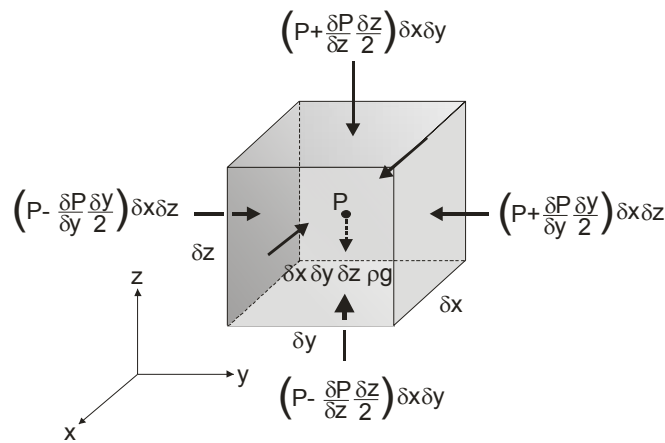

**Figure 2.3.** Pressure variation around a point

The total force in  $y$  direction  $F_y$  is then given by

$$F_y = \left( P - \frac{\delta P}{\delta y} \frac{\delta y}{2} \right) \delta x \delta z - \left( P + \frac{\delta P}{\delta y} \frac{\delta y}{2} \right) \delta x \delta z = -\frac{\delta P}{\delta y} \delta y \delta x \delta z$$

Since the fluid is at rest,  $F_y = 0$ . Therefore,

$$\frac{\delta P}{\delta y} = 0 \quad (2.7)$$

Similarly, it can be shown that

$$\frac{\delta P}{\delta x} = 0 \quad (2.8)$$

Force balance in z direction gives

$$F_z = -\frac{\delta P}{\delta z} \delta y \delta x \delta z - \rho g \delta y \delta x \delta z = 0$$

This gives

$$\frac{\delta P}{\delta z} = -\rho g \quad (2.9)$$

Equation 2.9 suggests that the pressure gradient in the direction of gravity is equal to the weight of unit volume of the fluid.

By taking the limit  $\delta z \rightarrow 0$ , Equation 2.9 reduces to

$$\frac{dP}{dz} = -\rho g \quad (2.10)$$

Please click the advert

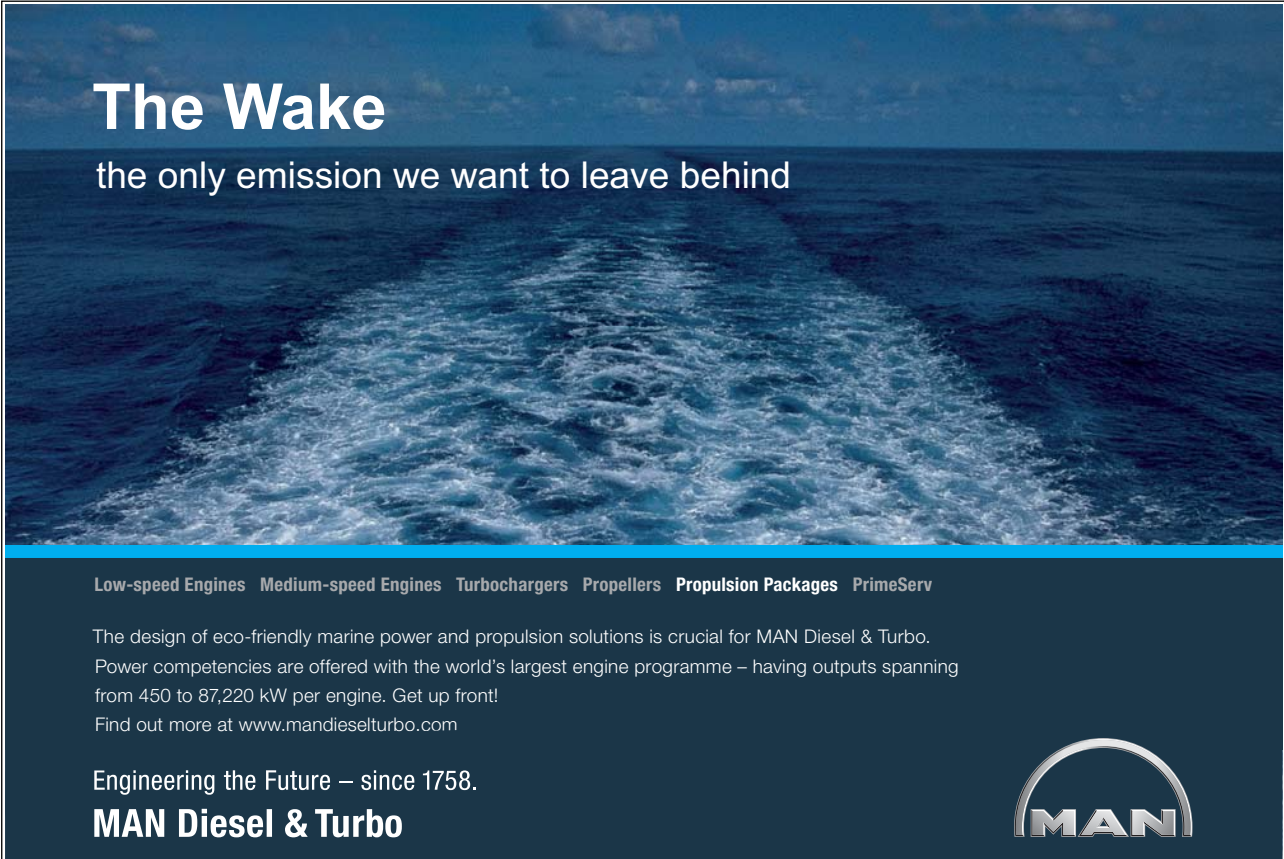

**The Wake**  
the only emission we want to leave behind

Low-speed Engines Medium-speed Engines Turbochargers Propellers Propulsion Packages PrimeServ

The design of eco-friendly marine power and propulsion solutions is crucial for MAN Diesel & Turbo. Power competencies are offered with the world's largest engine programme – having outputs spanning from 450 to 87,220 kW per engine. Get up front! Find out more at [www.mandieselturbo.com](http://www.mandieselturbo.com)

Engineering the Future – since 1758.  
**MAN Diesel & Turbo**





Taking the limit  $\delta z \rightarrow 0$  suggests that we have shrunk the volume to an infinitesimally small region. This emphasizes the spatial continuity of the property.

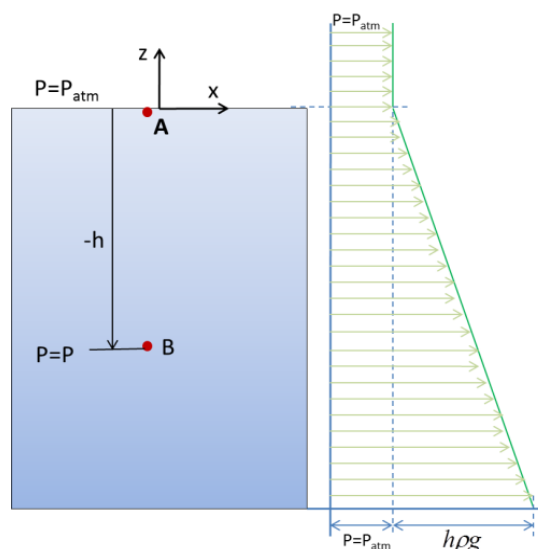

Figure 2.4. Pressure variation in the direction of gravity

Equation 2.10 gives an important relationship between the pressure and the height of the fluid. Integrating equation 2.10 from 0 to a depth of  $h$  gives

$$\int_{P_{atm}}^P dp = \int_0^{-h} -\rho g dz$$

$$\int_{P_{atm}}^P dp = \int_0^{-h} -\rho g dz \quad (2.11)$$

Equation 2.11 applies when

1. Fluid is static
2. Gravity is the only body force
3.  $z$  axis is vertical and upward

Equation 2.11 suggests that the pressure at any point of a fluid at rest is given by the sum of  $\rho gh$  and the pressure above the body of fluid. For example, if it is a tank full of water open to atmosphere, then the pressure at the bottom of the tank is given by  $\rho gh$  + atmospheric pressure. Would it not be surprising to realise that the force acting on a dam holding a massive body of water only depend on the depth of the water not the volume held by it?

Equations 2.7 and 2.8 suggest that for fluids at rest, there are no pressure gradients in the plane normal to the direction of the gravitational force. This leads to the conclusion that *the pressure at any two points at the same level in a body of fluid at rest will be the same.*

## 2.4 Pressure and head

Pressure has the units  $\text{N/m}^2$ . This could be written as  $\text{J/m}^3$  and pressure could be defined as the energy per unit volume of the fluid. The  $h\rho g$  in equation 2.11 gives the same units indicating that it is a form of energy. In fluid mechanics a common term used to indicate pressure is the *head*. *Head is defined as the energy per unit weight of fluid.*

Dividing equation 2.11 by  $\rho g$ , we get the head due to the height of a liquid column as

$$\frac{P - P_{atm}}{\rho g} = \frac{h\rho g}{\rho g} = h \quad (2.12)$$

Energy per unit weight or the head at a point within a static fluid is simply given by the height of the fluid above the point. Head is a concept we will encounter again when we discuss dynamics in chapter 4 and pumping of fluids in chapter 7.

## 2.5 Measurement of pressure

Pressure is a very important characteristic of fluids. As a result there are many measuring techniques used to measure pressure. As shown in equation 2.11, height of a liquid column could be used to measure pressure.

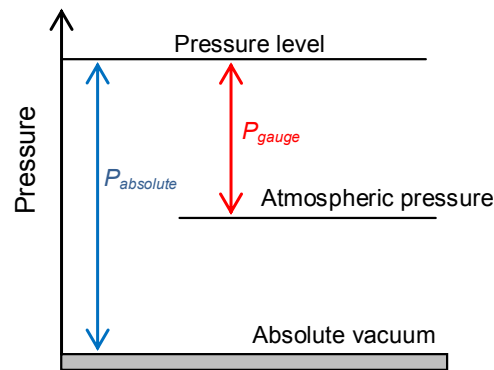

**Figure 2.5.** Relationship between gauge, absolute and atmospheric pressures.

It is essential to understand that the pressure is measured relative to the atmospheric pressure. In other words, some measuring techniques measure the pressure difference between the fluid and the atmosphere. This is called the *gauge pressure*. For instance,  $P - P_{atm}$  gives the gauge pressure. To obtain the *absolute pressure* one has to add the atmospheric pressure to the gauge pressure. Absolute pressure is measured relative to an absolute vacuum (zero pressure).

$$P_{gauge} = P_{absolute} - P_{atm \text{ here}}$$

Figure 2.5 shows a graphical representation of this equation.

The absolute value of the atmospheric pressure is 101325 Pa. In most cases  $1.01 \times 10^5$  Pa (101kPa) is used for simplicity.

## 2.5.1 Barometer

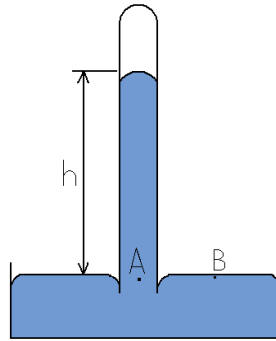

Figure 2.6 Torricelli's barometer

*Evangelista Torricelli* (1608-47 AD) studied a theory formulated by Aristotle (384-22 BC) stating that nature abhors a vacuum. This theory is known as “*horror vacui*”. This suggests that nature does not favour absolute emptiness and therefore, draws in matter (gas or liquid) to fill the void. Torricelli's study led to the discovery of the manometer.

Manometer is a straight tube sealed at one end filled with mercury and the open end immersed in a container of mercury as shown in Figure 2.6. Mercury drains out of the tube creating a vacuum until the pressure at point A equals the pressure at point B which is just below the free mercury surface in the container. Pressure at points on the same plane within a fluid remains equal. Therefore, Pressure at point A,  $P_A$ , is equal to Pressure at point B,  $P_B$ . Pressure at point B is as same as the atmospheric pressure.

Please click the advert

**I WANT TO CHANGE DIRECTION,  
AND THE WORLD.**

[GOT-THE-ENERGY-TO-LEAD.COM](http://GOT-THE-ENERGY-TO-LEAD.COM)

We believe that energy suppliers should be renewable, too. We are therefore looking for enthusiastic new colleagues with plenty of ideas who want to join RWE in changing the world. Visit us online to find out what we are offering and how we are working together to ensure the energy of the future.

**RWE**  
The energy to lead

Download free ebooks at [bookboon.com](http://bookboon.com)

$$P_A = P_B$$

Pressure at point A is given by

$$P_A = h\rho g$$

Therefore, the atmospheric pressure  $P_{atm} = P_B = h\rho g$  (2.13)

Since  $\rho g$  is a constant, height of the mercury column could be used as a measure of the pressure. This is how mercury millimetre (Hg mm) became a unit of pressure. In honour of Torricelli, 1/760 of the standard atmospheric pressure is called a Torr.

Manometer of this type is called the “barometer” and is used to measure atmospheric pressure.

*Exercise*

Considering the fact that the  $1 \text{ atm} = 101325 \text{ Pa}$ , calculate the corresponding height of the mercury column in a barometer. Density of mercury is  $13590 \text{ kg/m}^3$ .

### 2.5.2 U-tube manometer

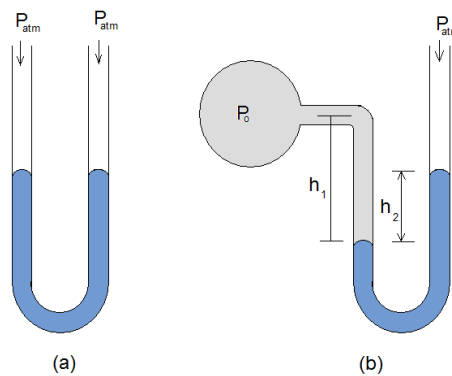

**Figure 2.7** U-Tube manometer

Barometer has limited applications. It is widely used to measure atmospheric pressure. However, the principle could be used to measure pressure relative to the atmospheric pressure or pressure difference between two points. For this purpose, a U-tube partially filled with mercury is used. When the both ends of the U-tube are open to the atmosphere, the mercury column balances giving the same height in both arms of the U tube (see Figure 2.7(a)). When one end is open to the atmosphere and the other end to a vessel with a pressure different from the atmosphere, the mercury column moves to a new equilibrium position giving a height difference in the U-tube as shown in Figure 2.7 (b).

Suppose the fluid in the bulb has a density  $\rho_1$  and the density of mercury to be  $\rho_M$ . Furthermore, assume the pressure inside the bulb to be  $P_0$ . Once the mercury column attains equilibrium, a simple force balance at a point just inside the static mercury meniscus will give

$$P_0 + h_1\rho_1\mathbf{g} = P_{atm} + h_2\rho_M\mathbf{g}$$

Rearranging terms gives

$$P_0 - P_{atm} = h_2\rho_M\mathbf{g} - h_1\rho_1\mathbf{g} \quad (2.14)$$

Manometers could be used to measure the pressure difference between two points. Consider an arrangement as shown in Figure 2.8. A U-tube partially filled with a heavier liquid, mercury in most cases, connected to a pipe across a restriction in the pipe. Density of the fluid in the pipe is  $\rho_L$  and the density of the heavy liquid is  $\rho_M$ . Pressure at two tapings to which the manometer arms are connected are  $P_1$  and  $P_2$  ( $P_1 > P_2$ ).

The space in the tube above the heavy fluid in the manometer is filled with the same fluid that flows in the pipe. This type of setting, when the pipe contains water and the heavy fluid is the mercury, is called “water over mercury” manometer. Heavy liquid attains equilibrium forming a height difference  $\Delta h$ . The line A-A marks the level of the heavy liquid (mercury). Pressure at this level in both arms should be equal.

Therefore, the pressure difference is given by

$$P_1 + h_1\rho_L\mathbf{g} = P_2 + h_2\rho_L\mathbf{g} + \Delta h\rho_M\mathbf{g} \quad (2.14)$$

$$P_1 - P_2 = \Delta h\rho_L\mathbf{g} \left( \frac{\rho_M}{\rho_L} - 1 \right)$$

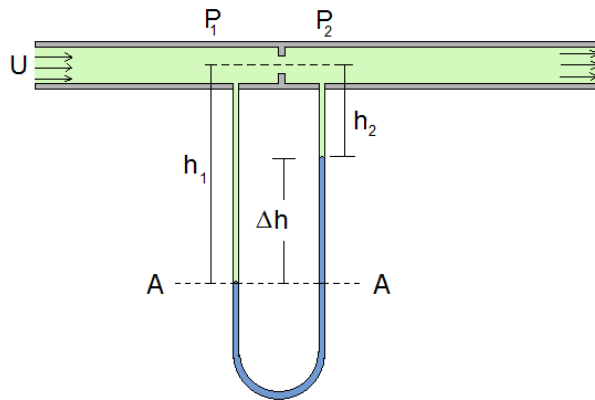

Figure 2.8 use of manometer to measure differential pressure

### 2.5.3 Inclined-tube manometer

Manometers shown in Figure 2.7 and 2.8 are easy to use with pressure differences that would give considerable height differences. To measure small pressure differences the sensitivity of the manometer has to be increased. This is achieved by inclining one arm of the U-tube as shown in Figure 2.9.



You're full of *energy*  
and *ideas*. And that's  
just what we are looking for.

Looking for a career where your ideas could really make a difference? UBS's Graduate Programme and internships are a chance for you to experience for yourself what it's like to be part of a global team that rewards your input and believes in succeeding together.

Wherever you are in your academic career, make your future a part of ours by visiting [www.ubs.com/graduates](http://www.ubs.com/graduates).

[www.ubs.com/graduates](http://www.ubs.com/graduates)



© UBS 2010. All rights reserved.

Please click the advert

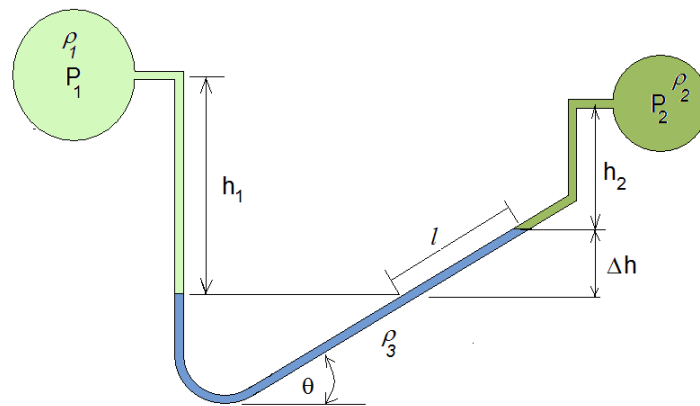

Figure 2.9 Inclined tube manometer

Once again by equating the pressure at equal levels, one can write

$$P_1 + h_1 \rho_1 \mathbf{g} = P_2 + h_2 \rho_2 \mathbf{g} + l \sin \theta \rho_3 \mathbf{g}$$

Rearranging terms gives

$$P_1 - P_2 = -(h_1 \rho_1 - h_2 \rho_2) \mathbf{g} + l \sin \theta \rho_3 \mathbf{g}$$

If the pipes contain the same fluid (i.e.  $\rho_1 = \rho_2$ ) then above equation reduces to

$$P_1 - P_2 = l \sin \theta \rho_3 \mathbf{g} - \Delta h \rho_1 \mathbf{g}$$

Further simplification gives

$$P_1 - P_2 = l \sin \theta \mathbf{g} (\rho_3 - \rho_1) \tag{2.15}$$

This result is obtained using the relationship  $l \sin \theta = \Delta h$ . By selecting an appropriate inclination angle  $\theta$ , one can increase  $l$  to be a measurable length.

#### 2.5.4 Bourdon gauge

Manometers are somewhat difficult to use. As a result more compact, liquid free measuring techniques are invented. Of these, the Bourdon gauge is a widely used measuring technique. Bourdon gauge measures the pressure relative to the atmospheric pressure. It contains a coiled tube connected to an indicator. The metal tube (made of copper in most cases), when expand under higher pressure, moves the indicator on a dial. The dial is calibrated so that the pressure could be read directly. The mechanism is shown in Figure 2.10.

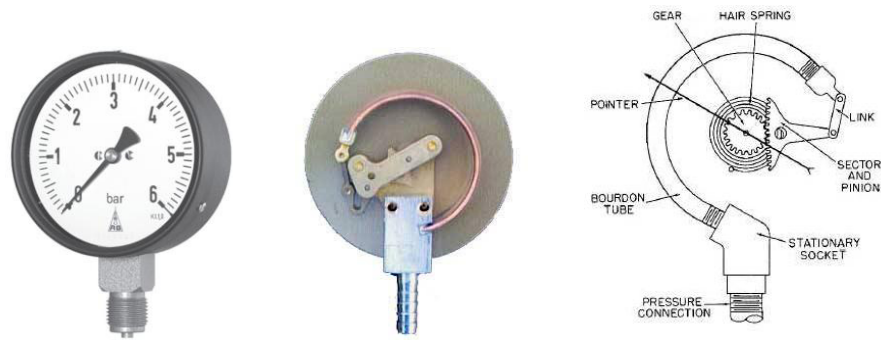

Figure 2.10. Bourdon gauge

Transducers that generate an electrical signal proportional to the applied pressure are widely used in chemical industries where process control is carried out remotely. These transducers use electric properties such as capacitance or piezoelectric voltage induction to infer pressure. These transducers, though expensive compared to traditional gauges, provide high accuracy and has small footprint on the system.

#### Exercise

*Barometric condensers not only condense the water vapour but also to create a low pressure inside process evaporators. It consists of a condensing chamber and a barometric leg similar to that of a mercury manometer. What is the height of the barometric leg required to generate a 1atm vacuum?*

## 2.6 Use of hydraulic pressure

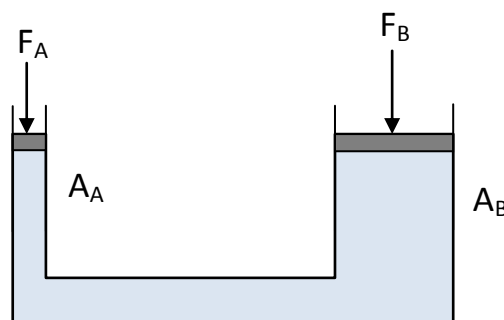

Figure 2.11. Hydraulic jack

In section 2.2 we have discussed an important characteristic of pressure in a fluid: pressure at a point is same in all directions. The proof given in 2.2 is first provided by Blaise Pascal (1623-1662 AD). He also observed that *a pressure change in one part of a fluid at rest in a closed container is transmitted without a loss to all parts of the fluid and the walls of the container.* This is known as the Pascal's law in hydraulics. This leads to an interesting engineering application.



Consider two pistons with different surface areas confining a fluid in a u-shaped cavity as shown in Figure 2.11. Suppose the area  $A_A \ll A_B$ . Consider the pistons are at the same level.

Piston A exerts a pressure  $F_A/A_A$  on the fluid and piston B exerts a pressure  $F_B/A_B$ . Since both pistons are at the same height,

$$\frac{F_A}{A_A} = \frac{F_B}{A_B}$$

Therefore,  $F_B = \frac{A_B}{A_A} F_A$  (2.16)

By selecting the areas, one can balance a large force on  $A_B$  by applying a small force on  $A_A$ . For example, consider a small car that weighs 1200kg. Assume it is parked on a platform that connected to the piston B which has an area  $A_B = 0.125 \text{ m}^2$  (0.4 m diameter). Suppose the area of the small piston  $A_A = 0.008 \text{ m}^2$  (0.1m diameter). The required force on piston  $A_A$  to balance the car is given by

$$F_A = \frac{A_A}{A_B} F_B$$

$$F_A = \frac{0.008}{0.125} \times 1200 \times 9.81 = 753 \text{ N}$$

This means that by placing a mass of 77kg on piston  $A_A$ , one can balance a mass of 1200 kg on the larger piston. This principle is used in many hydraulic applications including jacks, presses, and hoists.

Please click the advert



## CAREER KICKSTART

An app to keep you in the know

Whether you're a graduate, school leaver or student, it's a difficult time to start your career. So here at RBS, we're providing a helping hand with our new Facebook app. Bringing together the most relevant and useful careers information, we've created a one-stop shop designed to help you get on the career ladder – whatever your level of education, degree subject or work experience.

And it's not just finance-focused either. That's because it's not about us. It's about you. So download the app and you'll get everything you need to know to kickstart your career.

So what are you waiting for?

Click [here](#) to get started.

## 2.7 Buoyancy

In a fluid, the pressure increases linearly with the depth. As a result, any submerged body feels an upward force due to the difference of pressure acting on it. To illustrate this point consider a cylindrical object immersed in a liquid as shown in Figure 2.12.

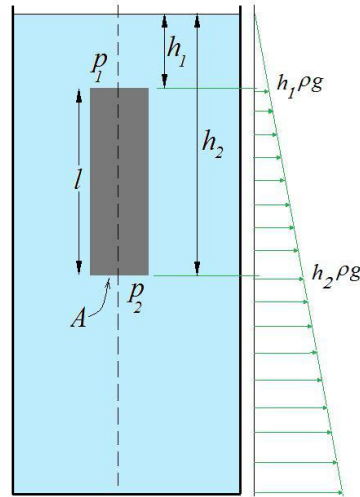

Figure 2.12.

The cylinder experiences a range of pressure values on its sides. The upper surface experiences a pressure  $p_1$  and the lower surface experiences a pressure  $p_2$ . The cylindrical surface experiences an equal pressure at any cross horizontal cross section. Therefore, there is no resultant force acting on the cylindrical surface. However, the pressure exerted by the fluid is different at the top and the bottom surfaces. Upward force due to the hydrostatic pressure is given by

$$F_B = p_2 A - p_1 A$$

Using the fact that  $p_1 = h_1 \rho g$  and  $p_2 = h_2 \rho g$

$$F_B = A(h_2 - h_1) \rho g$$

Therefore,  $F_B = A l \rho g = V \rho g$  (2.17)

This equation does not depend on the geometric shape of the object immersed in the fluid but only the volume. *Therefore, the upward force (buoyancy) acting on a body immersed in a fluid is equal to the weight of an equivalent volume of the fluid.* This law is first discovered by the Greek philosopher, who anecdotally ran nakedly through the city when he discovered it, Archimedes.

Law of buoyancy suggests that despite the material the bodies were made of, equal volumes experience the same buoyancy force. For example, the buoyancy acting on  $10 \text{ cm}^3$  of wood immersed in water is as same as the buoyancy acting on  $10 \text{ cm}^3$  of lead.

Let the mass of the body be  $m$ . Then

- a) if  $F_B < mg$  the body sinks to the bottom
- b) if  $F_B = mg$  the body floats and
- c) if  $F_B > mg$  the body rises to the surface.

The buoyancy acting on partially immersed bodies like floating buoys and ships is equal to the weight of the fluid of the partial volume immersed in the fluid.

#### Exercise

A hot air balloon is attached to a basket that weighs 125kgs. The deflated balloon weighs 75 kg. The balloon is filled with hot air at 120 °C. Assuming the shape of the balloon to be spherical, calculate the diameter of the balloon just as it lifts off the ground. The density of air at 120 °C is  $0.8\text{kg/m}^3$

## 2.8 Force on immersed plates

### 2.8.1 Centroid of a lamina

Before moving on to forces acting on immersed plates, few basic concepts in mechanics have to be discussed. For any solid shape the mass is distributed throughout the body. If the density is constant and the material of the solid body is uniformly distributed then so is the mass. However, any solid body can be balanced around at least three axes. The point at which these three axes intersect is known as the *centre of mass of the body*. Hypothetically, the mass can be considered as acting at this point. The location of this point can be calculated by taking the moment of mass around an arbitrarily selected reference axis.

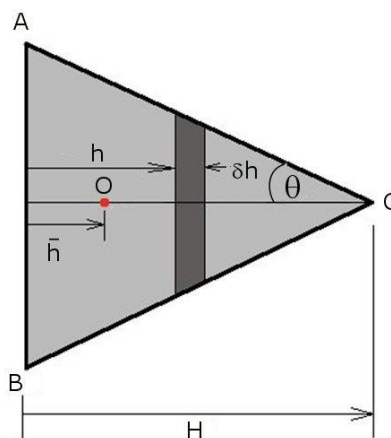

Figure 2.13. Centroid of an isosceles triangle

When a thin plate like body is considered, the centre of mass is referred to as the *centroid*. The best example for such a body is a metal plate of any shape with uniform thickness. Even though the mass is evenly distributed, one can treat it as a lamina with its mass concentrated at centroid. We can easily calculate the position of the centroid for basic shapes by taking the moment around a reference axis.

For example, consider an isosceles triangle ABC made of a thin plate as shown in Figure 2.13. AB is taken as the reference axis. We adopt a sign convention such that all the distances measured upwards from AB are positive. Assume a point O, distance from AB as the centroid of ABC. The overall weight of the triangle can be considered as acting downwards at this point. Taking the moment of this force around AB gives

$$M_o = \frac{1}{2} \rho g a H \bar{h} \quad (2.18)$$

$a$  is the length of AB.

If the moment of the weight a differential are element is taken around AB, we can write

$$M = \int_0^H \rho g \delta A h$$

When the density is constant and the mass is uniformly distributed,

$$M = \rho g \int_0^H h \delta A \quad (2.19)$$

The quantity  $\int_0^H h \delta A$  is the first moment of area of the triangle around AB. Since both  $M$  and  $M_o$  are the same quantity, from equations (2.18) and (2.19),

$$\frac{1}{2} \rho g a H \bar{h} = \rho g \int_0^H h \delta A \quad (2.20)$$

$$\frac{1}{2} a H \bar{h} = \int_0^H h \delta A \quad (2.21)$$

$$\delta A = 2(H - h) \tan \theta \delta h$$

where  $\theta$  is the angle as shown in figure 2.13. Substituting for  $\delta A$  from equation (2.21) in equation (2.20)

$$\frac{1}{2} a H \bar{h} = \int_0^H 2h(H - h) \tan \theta dh$$

$$\frac{1}{2} a \bar{h} = \frac{2}{6} H^2 \tan \theta$$

$$a = 2H \tan \theta$$

Therefore,  $\bar{h} = \frac{1}{3}H$

This shows that the centroid of an isosceles triangle is located  $\frac{1}{3}$  of the height of the triangle away from the base. Furthermore, the equation (2.20) shows that

$$\int_0^H h \delta A = A \bar{h} \quad (2.22)$$

### 2.8.2 Force acting on an immersed plate

A similar approach as above can be used to analyse the force acting on an immersed plate. Consider a rectangular plate immersed in a body of water forming an inclination angle  $\theta$  with the unperturbed liquid surface as shown in Figure 2.14. Since the pressure varies with the depth of the liquid, the force at different levels varies. The hydrostatic pressure  $h\rho g$  at any depth  $h$  acts normal to the surface. For example, the force acting on a narrow area on the plate  $h_1$  below the surface,  $p_1 \delta A$ , is smaller than the force experienced by a similar area  $h_2$  below the surface,  $p_2 \delta A$ . To calculate the force on the surface, one can subdivide the plate to small areas as shown in Figure 2.14 and add up all the forces acting on those area elements.

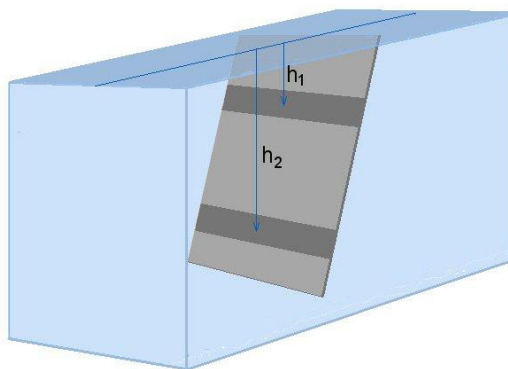

**Figure 2.14.** Immersed rectangular plate

The resultant force acting on the plate is then can be written as

$$F_R = p_1 \delta A + p_2 \delta A + \dots + p_n \delta A = \sum_{i=1}^n p_i \delta A = \int_0^A p dA$$

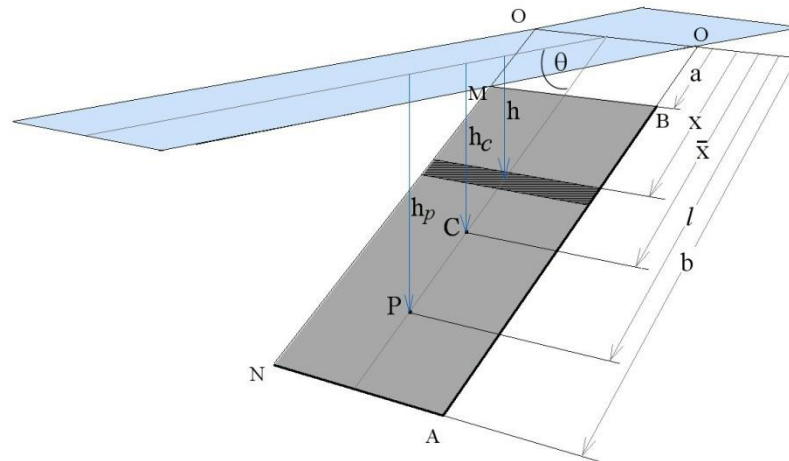

Figure 2.15. Centre of pressure of an immersed plate

Even though the pressure is distributed on the plate, the total pressure can be considered as acting at a one point on the plate, just like the mass of the plate is considered acting at the centroid. This point, at which the resultant hydrostatic force is acting on the plate, is called the *centre of pressure*. To find the centre of pressure, an approach similar to the one we used to determine the centroid can be employed. For this, consider a rectangular plate ABMN totally immersed in a liquid of density  $\rho$  as shown in Figure 15. The plate is inclined to the free surface of the liquid by an angle  $\theta$ . The centroid C of the plate is  $h_c$  below the liquid surface. OO is the line that marks the intersection of the plate and the free surface

Please click the advert

**ORACLE®**

**Be BRAVE**  
**enough to reach for the sky**

Oracle's business is information - how to manage it, use it, share it, protect it. Oracle is the name behind most of today's most innovative and successful organisations.

Oracle continuously offers international opportunities to top-level graduates, mainly in our Sales, Consulting and Support teams.

If you want to join a company that will invest in your future, Oracle is the company for you to drive your career!

<https://campus.oracle.com>



**ORACLE®**

**ORACLE IS THE INFORMATION COMPANY**

had the plate ABMN extended to intersect the free surface. The distances are measured along the plane of the immersed plate taking OO as the reference axis as shown in the Figure 2.15. For example the centroid C is distance away from OO

Consider a small area  $\delta A$  on one side of the plate  $x$  distance away from OO. The pressure acting on this element depends on the vertical depth  $h$ .

Force acting on this area element  $\delta F = p\delta A = \rho g h \delta A$

The total force acting on the rectangular plate is given by the sum of all  $\delta F$  forces.

$$F_R = \sum \delta F = \rho g \sum h \delta A = \rho g \int_{h_{MB}}^{h_{NA}} h dA \quad (2.23)$$

From equation (2.22),  $\int h \delta A = A\bar{h}$ . Therefore,

$$F_R = \rho g A \bar{h} \quad (2.24)$$

Suppose the location of the *centre of pressure* is at point P on the plate  $l$  distance away from OO. The resultant force  $F_R$  acts at this point normal to the plane. The moment of this resultant force about the axis OO should be equal to the sum of moment of the forces acting on all  $\delta A$  area elements about the same axis.

Taking the moment of the resultant force about OO gives

$$M_{F_R} = \rho g A h_c l \quad (2.25)$$

Sum of the moments of the forces acting on each area element about OO give

$$M_{\delta F} = \rho g \int_a^b h x dA \quad (2.26)$$

$$h = x \sin \theta \quad (2.27)$$

$$\text{Therefore, } M_{\delta F} = \rho g \sin \theta \int_a^b x^2 dA \quad (2.28)$$

The integral  $\int_a^b x^2 dA$  gives the second moment of area (indicated by) of the surface about the reference axis OO.

Since the moments given in equations (2.25) and (2.28) are equal,

$$\rho g A h_c l = \rho g \sin \theta \int_a^b x^2 dA \quad (2.29)$$

$$l = h_p / \sin \theta \quad (2.30)$$

$$A h_c l = \sin \theta \int_a^b x^2 dA \quad (2.31)$$

$$l = \frac{\sin\theta \int_a^b x^2 dA}{Ah_c} \quad (2.32)$$

$l$  is the distance to the centre of pressure from the reference axis OO measured along the plane of the immersed surface. The vertical depth . Therefore,

$$h_p = \frac{\sin^2\theta \int_a^b x^2 dA}{Ah_c} \quad (2.33)$$

Since the second moment of area is given by

$$I_{OO} = \int_a^b x^2 dA \quad (2.34)$$

Substituting equation (2.34) in equation (2.33)

$$h_p = \frac{I_{OO} \sin^2\theta}{Ah_c} \quad (2.35)$$

$h_p$  given in equation (2.33) can be determined by carrying out the integral easily for regular shapes. For example, considering the rectangular plate ABMN, assuming the breadth of the plate to be  $s$ , one can carry out the integration.

$$dA = s dx$$

$$A = s(b - a)$$

Substituting for  $da$  and  $A$  in equation (2.33)

$$\begin{aligned} h_p &= \frac{\sin^2\theta \int_a^b x^2 dx}{(b - a)h_c} \\ &= \frac{\sin^2\theta}{(b - a)h_c} \left( \frac{b^3 - a^3}{3} \right) \\ h_p &= \frac{\sin^2\theta}{3h_c} (b^2 + ab + a^2) \end{aligned} \quad (2.36)$$

If the plate is normal to the free surface, then

$$h_p = \frac{(b^2 + ab + a^2)}{3h_c} \quad (2.37)$$

If the plate is positioned horizontally then the hydrostatic force on each area element is equal. As a result the resultant force acts at the centroid normal to the surface.

Even though we considered a rectangular geometry for the derivation presented here, the equation (2.35) holds for a lamina of any shape.



2.8.3 Force acting on an immersed curved plate

Curved surfaces are used to hold liquid masses, most commonly in civil engineering applications. Thames barrier is one of the examples for this type of applications. Depending on the application, the liquid may be held above (Figure 2.16 (a)) or below (figure 2.16 (b)).

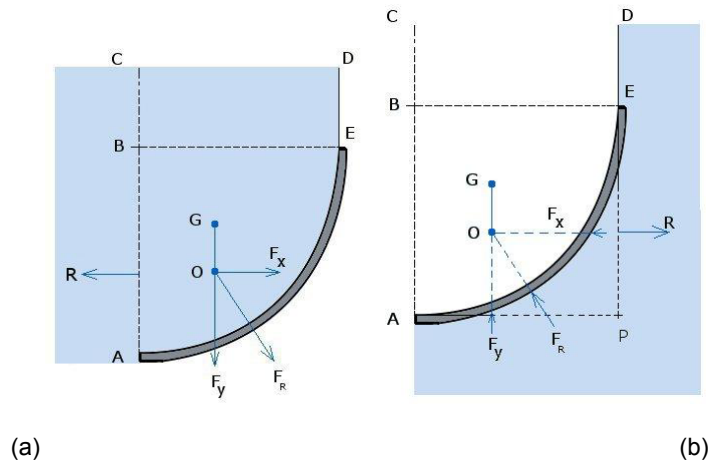
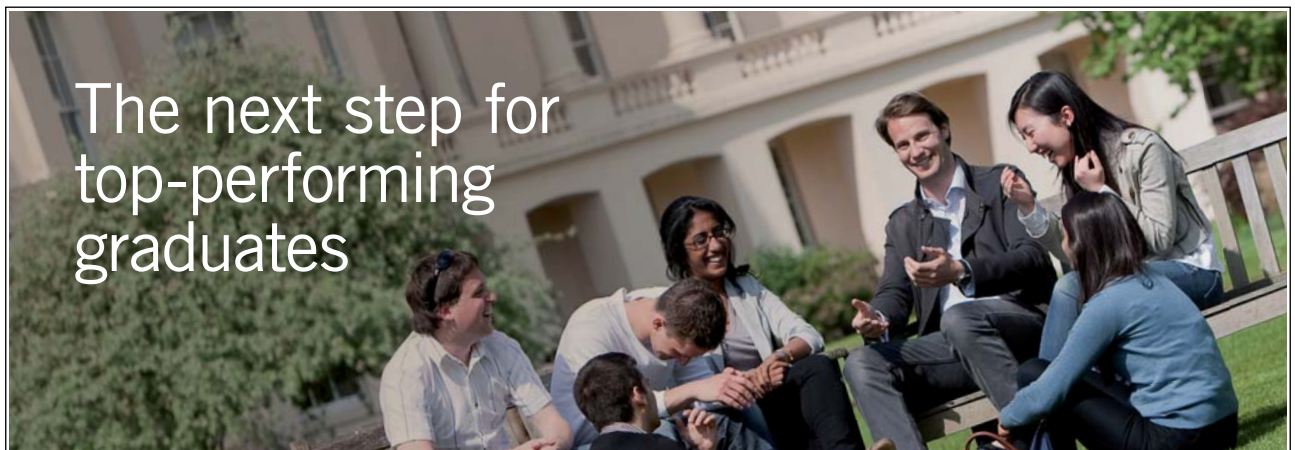

Figure 2.16. Hydrostatic forces acting on curved surfaces



Please click the advert

The next step for top-performing graduates

**Masters in Management**

Designed for high-achieving graduates across all disciplines, London Business School's Masters in Management provides specific and tangible foundations for a successful career in business.

This 12-month, full-time programme is a business qualification with impact. In 2010, our MiM employment rate was 95% within 3 months of graduation\*; the majority of graduates choosing to work in consulting or financial services.

As well as a renowned qualification from a world-class business school, you also gain access to the School's network of more than 34,000 global alumni – a community that offers support and opportunities throughout your career.

For more information visit [www.london.edu/mm](http://www.london.edu/mm), email [mim@london.edu](mailto:mim@london.edu) or give us a call on **+44 (0)20 7000 7573**.

\* Figures taken from London Business School's Masters in Management 2010 employment report



In figure 2.16 the resultant force acting on the curved surface is given by  $F_R$ . This force acts through the centre of pressure. The horizontal and vertical components of the resultant force are given by  $F_x$  and  $F_y$  respectively. The fluid volumes contained in the areas represented by ABE and APE in above figures are at rest. Therefore, the horizontal force acting normal to AB should be equal and opposite to  $F_x$ . Furthermore, the two forces must act along the same line to preserve the equilibrium. R is the resultant force due to the liquid volume acting on the projection of AE on the vertical plane. From equation 2.24, the force acting on the vertical area A formed by the projection of AE is given by

$$F_y = R = \text{Resultant hydrostatic force acting on the projected area of AE} \quad (2.38)$$

From equation (2.24)  $F_y = R = \rho g A \bar{h}$

where  $\bar{h}$  is the depth of the centroid of the projected area A from the free surface of the liquid. This force acts at the pressure centre of the projected area.

For the situation shown in the figure 2.16 (a), the vertical component  $F_y$  is due to the weight of the fluid held by the curved surface AE. This is the weight of the fluid volume held in AEDC. The weight of the fluid acts vertically down through the centre of gravity of AEDC.

$$F_y = \text{Weight of the liquid vertically above AE} \quad (2.39)$$

In the case of Figure 2.16 (b), the force acting vertically upward is due to the liquid held by the curved surface. Should the area vertically above AE is filled with the same liquid after removing the curved surface it should be in equilibrium when the fluid is at rest. If we assume a hypothetical curved surface equivalent to AE, the force  $F_y$  should be balanced by the weight of the liquid held above that surface. Therefore, the vertical component will be as same as given by the equation (2.39).

The resultant force  $F_R$  is given by

$$F_R = \sqrt{F_x^2 + F_y^2} \quad (2.40)$$

In chemical engineering context, this applies to pressure vessels with curved end caps. In these situations, a free surface may not exist. In such cases, a hypothetical free surface can be assumed at a height if the pressure  $p$  at a given point is known.

## References

1. Douglas, J.F., Gasiorek, J., Swaffield, J., and Jack, L., Fluid Mechanics 6<sup>th</sup> Ed., Prentice Hall, 2011.
2. White, F.M., Fluid Mechanics, 7<sup>th</sup> Ed. McGraw-Hill, 2011.
3. Robert W. Fox, R.W., McDonald, A.T. and Pritchard P.J., Introduction to Fluid Mechanics, 7<sup>th</sup> Ed, 2005.

# 3 Dimensional analysis

## Introduction

Dimensional analysis is a vastly important yet a simple tool in an engineer's toolbox that allows quick analysis of physical systems (such as turbulent flows) by reducing the number of variables. Dimensional analysis leads to deriving dimensionless numbers such as Reynolds number, Prandtl number and many more. These dimensionless numbers are formed clustering several variables together. This reduces the number of variables making complex problems somewhat easy to analyse. Furthermore, these numbers provide a basis for scaling up/down of process equipment while retaining a similarity between the process conditions.

In day to day applications we measure, lengths, rates, time, force etc. to quantify physical observations. These have units of measurements. For example length can be measured in feet or meters. For historic reasons same measurement can have different units. One unit can be converted to another using conversion factors. To remove the ambiguity of various unit systems most of the countries now have adopted the *International System of Units* or SI system (the term SI originate from the French *Système international d'unités*). The SI system defines units for 7 primary physical quantities. It also uses the base of ten in measurements rather than odd numbers relating larger measuring unit to smaller units.

The 7 primary quantities and their units are given in the Table 3.1. These quantities are called dimensions and have assigned symbols (given in brackets in Table 3.1). Most commonly used dimensions are length [L], Mass [M], and time [T] and is referred to as MKS (meter-kilogram-seconds) system. All other physical quantities can be expressed using these basic dimensions. For example, pressure as you learned in chapter 2 is measured using a unit called Pascal. Pressure is force per unit area and force is given by the rate of change of momentum. Momentum involves mass and time rate of changing distance (length). Area is given by length squared. Therefore, pressure has the dimensions  $[ML^{-1}T^{-2}]$ . Any unit of measure can be broken down into basic dimensions in this manner. Table 3.2 shows some of the units that can be expressed in terms of primary quantities.

In fluid mechanics the basic measurements are made on amount of flow [M], distances [L], time [T] and temperature  $[\Theta]$  or  $[MLT\Theta]$  in short. In this system, velocity and force have dimensions  $[LT^{-1}]$  and  $[MLT^{-2}]$  respectively. Even though Force is a derived quantity sometimes it is considered as a dimension of its own right and indicated by [F].

Quantity (Dimension)	Unit	Unit symbol
Mass [M]	Kilogram	kg
Length [L]	meter	m
Temperature $[\Theta]$	Kelvin	K
Time [T]	Second	s
Electric Current [I]	Ampere	A
Amount of substance [N]	Mole	mol
Luminous intensity $[I_v]$	Candela	cd

**Table 3.1** Basic quantities measurement and their SI units

Quantity	Unit	Unit symbol	Primary units	Dimensions
Force	Newton	N	kg m s <sup>-2</sup>	MLT <sup>-2</sup>
Energy	Joule	J (Nm)	Kg m <sup>2</sup> s <sup>-2</sup>	ML <sup>2</sup> T <sup>-2</sup>
Work	Watt	W (J s <sup>-1</sup> )	Kg m <sup>2</sup> s <sup>-3</sup>	ML <sup>2</sup> T <sup>-3</sup>
Voltage	Volt	V (W A <sup>-1</sup> )	Kg m <sup>2</sup> s <sup>-3</sup> A <sup>-1</sup>	ML <sup>2</sup> T <sup>-3</sup> I <sup>-1</sup>
Dynamic viscosity	Poise	P	(0.1) kg m <sup>-1</sup> s <sup>-1</sup>	ML <sup>-1</sup> T <sup>-1</sup>
Kinematic viscosity	Stokes	St	(10 <sup>-6</sup> ) m <sup>2</sup> s <sup>-1</sup>	L <sup>2</sup> T <sup>-1</sup>
Frequency	Hertz	Hz	s <sup>-1</sup>	T <sup>-1</sup>

**Table 3.2.** Some quantities expressed in derived units

### 3.1 Dimensional homogeneity

All the quantities measured have units associated with them. In mathematically treating the behaviour of natural systems it is customary to express one property such as force acting on a body in terms of other variables. For instance the force acting on a moving body is expressed in terms of the rate of change of momentum which is simply the multiplication of mass of the body and the acceleration it undergoes. This is the famous Newton's second law of motion.

$$Force = \frac{d}{dt}(\text{Momentum})$$

$$F = \frac{d}{dt}(mv) = m \frac{dv}{dt} = ma$$

# Destination MMU



Manchester  
Metropolitan  
University

MMU is proud to be one of the most popular universities in the UK. Some 34,000 students from all parts of the globe select from its curricula of over 1,000 courses and qualifications.

We are based in the dynamic yet conveniently compact city of Manchester, located at the heart of a sophisticated transport network including a major international airport on the outskirts. Parts of the campus are acclaimed for their architectural style and date back over 150 years, in direct contrast to our teaching style which is thoroughly modern, innovative and forward-thinking.

MMU offers undergraduate and postgraduate courses in the following subject areas:

- Art, Design & Performance
- Computing, Engineering & Technology
- Business & Management
- Science, Environmental Studies & Geography
- Law, Education & Psychology
- Food, Hospitality, Tourism & Leisure Studies
- Humanities & Social Science



For more details or an application form please contact MMU International.  
email: [international@mmu.ac.uk](mailto:international@mmu.ac.uk)  
telephone: +44 (0)161 247 1022  
[www.mmu.ac.uk/international](http://www.mmu.ac.uk/international)

Please click the advert

The dimensions of the left hand side are  $MLT^{-2}$ . The right hand side terms should give the same dimensions since the multiplication of the mass and the acceleration give the unbalanced force acting on the body. It can be seen that right hand side produces the same dimensions. Mass having the dimension  $M$  and the acceleration  $LT^{-2}$ , the product gives  $MLT^{-2}$  the units as same as the left hand side. This balance of dimensions in derived equations is known as the *principle of dimensional homogeneity*.

All the equations derived using first principles of physics and mechanics have this agreement in dimensions. If the equations have additive terms all the terms must have same dimensions. For example consider simple equation of motion that gives the distance a body would travel in time  $t$  starting at a distance  $s_0$  and travelling at a velocity  $v$  with an acceleration  $a$ .

$$s = s_0 + vt + \frac{1}{2}at^2$$

According to the principle of dimensional homogeneity, each term in this equation should bear the dimension of the length.

$$\begin{aligned} \text{Dimension of } s \text{ and } s_0 &= [L] \\ vt &= [LT^{-1} T] = [L] \\ at &= [LT^{-2} T^2] = [L] \end{aligned}$$

This can be used in general to test the accuracy of derived equations. However, it should be noted that in engineering there are equations that does not follow this rule. This is due to the fact that the relationships between quantities expressed in those equations are established empirically. Despite the imbalance in dimensions those equations are phenomenologically correct and can be used with confidence as they have proven to be acceptable. One such equation in fluid flow applications is Hazen-Williams formula that gives the volumetric flowrate of water,  $Q$ , in a smooth straight pipe with diameter  $D$ .

$$Q = 61.9D^{2.63} \left( \frac{dp}{dl} \right)^{0.54}$$

where  $\frac{dp}{dl}$  is the pressure drop per unit length. The flowrate  $Q$  has dimensions  $[L^3T^{-1}]$ . With the odd exponents on right hand side of the equation, it is evident that the dimensions are inhomogeneous in this equation. Nevertheless, Hazen-Williams equation is widely used in engineering to calculate the pressure drop (head loss) in pipes (for water).

The dimensional homogeneity in equations allows collecting physical parameters together to define nondimensional numbers such as Reynolds number. To deduce nondimensional groups associate with a physical system, a set of rules are to be followed these rules are given in *Buckingham's Pi theorem*.

## 3.2 Buckingham's Pi theorem

Lord Rayleigh has used nondimensional groups even though a formal method of deducing them was not presented. US physicist Edgar Buckingham put forward a formal methodology to deduce all nondimensional parameters associated with a problem in 1914. It has become widely known as the Buckingham's pi theorem since. It is called "pi" theorem after the mathematical notation  $\pi$  used to indicate the product of variables. In Buckingham's pi theorem,  $\Pi$  is used to indicate each independent grouping of physical parameters that forms a nondimensional group.

Buckingham's pi theorem states that *for a dimensionally homogeneous system with  $n$  variables (such as velocities  $u$  and  $v$ , pressure,  $p$  and time,  $t$ ) with  $m$  primary dimensions ( $M$ ,  $L$ , and  $T$ ), the number of independent nondimensional groups is equal to  $n-m$ .*

To form nondimensional groups

1. Identify and list all the physically independent variables associate with the phenomenon under investigation.

This gives the number of the total variables  $n$ . For example, assume the dependant variable is  $Q_0$  and the independent variables that describes it is  $Q_1, Q_2, \dots, Q_5$ . The functional relationship can be written as

$$Q_0 = f(Q_1, Q_2, Q_3, Q_4, Q_5)$$

Note that there are 6 variables altogether.

2. Analyse each variable to identify the total number of primary dimensions  $m$ .
3. Identify a subset of dimensionally independent variables from the full set listed in 1 above. The number of dimensionally independent variables cannot be greater than the number of the primary dimensions. For example, if  $M, L$  and  $T$  are the only primary dimensions, the number of nondimensional numbers to expect is  $6-3=3$  and the number of dimensionally independent variables is 3 or less. Suppose the dimensionally independent variables are  $Q_1, Q_2$  and  $Q_4$ . Each contains at least one primary dimension so that one cannot establish a pi group using this subset alone.
4. To form the pi groups, the dimensionally independent set is used. The dimensions of a physical quantity appear as a product of few primary dimensions raised to various powers. Keeping this as a general rule, pi groups can be formed by multiplying each of the remaining variables by the product of the dimensionally independent variables raised to various powers. Following above example, the three pi groups could be defined as

$$\Pi_1 = Q_1^a Q_2^b Q_4^c Q_0 \quad \Pi_2 = Q_1^a Q_2^b Q_4^c Q_3 \quad \Pi_3 = Q_1^a Q_2^b Q_4^c Q_5$$

The power of each primary dimension should vanish as pi groups are dimensionless.

5. Write the final dimensionless function.

To demonstrate the implementation of the pi theorem, consider pressure drop in a pipe. Following the steps described above, the variables that describe the pressure drop have to be established.

1. Pressure drop  $\Delta P$  depend on the viscosity  $\mu$ , density  $\rho$ , and mean velocity  $v$ , length of the pipe  $L$  and the diameter of the pipe  $D$ . Further, the wall roughness  $e$  has to be considered as the wall shear is dependent on it. Therefore,

$$\Delta P = f(\mu, \rho, v, L, D, e) \quad (3.1)$$

There are 7 variables altogether in this analysis.



2. Find the primary dimensions of each variable

$$\Delta P \approx [ML^{-1}T^{-2}]$$

$$\mu \approx [ML^{-1}T^{-1}]$$

$$\rho \approx [ML^{-3}]$$

$$v \approx [LT^{-1}]$$

$$L \approx [L]$$

$$D \approx [L]$$

$$e \approx [L]$$

The primary dimensions are M,L and T.

3. The number of variables is 7 and the number of primary dimensions is 3. Therefore the number of nondimensional groups would be 4.
4. Inspect the variables to select a subset of dimensionally independent variables. Mass is associated with three of the variables  $\Delta P$ ,  $\mu$  and  $\rho$ . The sub set is to be selected from the independent variables,  $\Delta P$  should not be considered. From the remaining two, density is to be selected as it offers the simplicity. For time, velocity can be used and for the length, diameter D is used as it remains the characteristic length for the geometry. The length of the pipe could vary and could specify in terms of the diameter.
5. Forming the four pi groups

$$\Pi_1 = \rho^a D^b v^c \Delta P$$

$$\Pi_2 = \rho^a D^b v^c \mu$$

$$\Pi_3 = \rho^a D^b v^c L$$

$$\Pi_4 = \rho^a D^b v^c e$$

Please click the advert



## Get Internationally Connected at the University of Surrey

MA Intercultural Communication with International Business  
MA Communication and International Marketing



### MA Intercultural Communication with International Business

Provides you with a critical understanding of communication in contemporary socio-cultural contexts by combining linguistic, cultural/media studies and international business and will prepare you for a wide range of careers.

### MA Communication and International Marketing

Equips you with a detailed understanding of communication in contemporary international marketing contexts to enable you to address the market needs of the international business environment.

For further information contact:

T: +44 (0)1483 681681

E: [pg-enquiries@surrey.ac.uk](mailto:pg-enquiries@surrey.ac.uk)

[www.surrey.ac.uk/downloads](http://www.surrey.ac.uk/downloads)

Consider  $\Pi_1$

$$\rho^a D^b v^c \Delta P \approx [ML^{-3}]^a [L]^b [LT^{-1}]^c [ML^{-1}T^{-2}] = [M]^0 [L]^0 [T]^0$$

Equating the powers of each dimension, three equations can be obtained for  $a$ ,  $b$  and  $c$ .

$$\begin{aligned} a + 1 &= 0 \\ -3a + b + c - 1 &= 0 \\ -c - 2 &= 0 \end{aligned}$$

Solving the three equations, values of  $a$ ,  $b$ , and  $c$  can be found.

$$a = -1, b = 0 \text{ and } c = -2$$

Therefore,

$$\Pi_1 = \rho^{-1} D^0 v^{-2} \Delta P = \frac{\Delta P}{\rho v^2}$$

Consider  $\Pi_2$

$$\rho^a D^b v^c \mu \approx [ML^{-3}]^a [L]^b [LT^{-1}]^c [ML^{-1}T^{-1}] = [M]^0 [L]^0 [T]^0$$

This gives following 3 equations

$$\begin{aligned} a + 1 &= 0 \\ -3a + b + c - 1 &= 0 \\ -c - 1 &= 0 \end{aligned}$$

Solving for  $a$ ,  $b$  and  $c$  gives

$$a = -1, b = -1 \text{ and } c = -1$$

$$\Pi_2 = \rho^{-1} D^{-1} v^{-1} \mu = \frac{\mu}{\rho v D} = \frac{1}{Re}$$

Consider  $\Pi_3$

$$\rho^a D^b v^c \mu \approx [ML^{-3}]^a [L]^b [LT^{-1}]^c [L] = [M]^0 [L]^0 [T]^0$$



$$\begin{aligned} a &= 0 \\ -3a + b + c + 1 &= 0 \\ c &= 0 \end{aligned}$$

Therefore  $b = -1$

$$\Pi_3 = \rho^0 D^{-1} v^0 L = \frac{L}{D}$$

Similarly, by considering one can show that

$$\Pi_4 = \rho^0 D^{-1} v^0 e = \frac{e}{D}$$

Therefore, the functional relationship can be written as

$$\frac{\Delta P}{\rho v^2} = f\left(\frac{\mu}{\rho v D}, \frac{L}{D}, \frac{e}{D}\right) = f\left(\frac{1}{Re}, \frac{L}{D}, \frac{e}{D}\right) \quad (3.2)$$

The Darcy-Weisbach equation is generally used in fluid mechanics to estimate the pressure loss. It shows that the pressure loss is of the form given by equation (3.2) above.

Please click the advert



Darcy-Weisbach equation written using the same notation as in above example is shown below.

$$\Delta P = f \frac{L}{D} \frac{\rho v^2}{2} \quad (3.3)$$

The nondimensional form of this equation is as follows.

$$\frac{\Delta P}{\rho v^2} = \frac{f L}{2 D} \quad (3.4)$$

The friction factor is denoted by  $f$ .

For Laminar regime  $f = \frac{64}{Re}$  (3.5)

For the turbulent flow regime the friction factor  $f$  is given by Colebrook-White equation.

$$\frac{1}{\sqrt{f}} = 1.14 - 2 \log_{10} \left( \frac{e}{D} + \frac{9.35}{Re \sqrt{f}} \right) \quad (3.6)$$

Inspection of both expressions for  $f$  shows that the inverse proportionality of the Reynolds number is in fact true. This shows how powerful the dimensional analysis is in relating the physical parameters through nondimensional numbers. However, it should be noted that the selection of the base set of dimensionally independent variables. This has to be done considering the dominant physics associated with the phenomenon under consideration.

### 3.3 Uses of dimensional analysis

Dimensional analysis is used to compare physical phenomena in various geometries. The comparison (used loosely in here) gives an indication how a system would behave. This is possible because dimensional analysis leads to similarity laws for the systems under consideration. This reduces the number of variables to consider in a given problem.

# 4 Basics of Fluid Flow

## Introduction

In the previous lecture on fluid statics we have discussed the fluid at rest. In this section we discuss about fluid flow and some concepts associated with flowing fluids. Given that the gasses are incompressible, the concepts discussed here apply to both liquids and gasses.

Characteristics of flowing fluid have generated lot of interest over time. There are evidences that some of the ancient civilizations have running water and drainage systems in place. Much later, Romans built aqueducts to supply water to cities from where the sources were found. These magnificent engineering achievements were made simply making use of the observation that water runs down an elevation spontaneously. The explanation to why it happens came much later when the knowledge about fluid flow gathered over time. For instance, Leonardo da Vinci has drawn sketches of turbulent flows well before a proper description came into existence (see figure 4.1). Structured presentation of the knowledge gathered over last two millennia on the behaviour of fluid flow is called fluid dynamics.



**Figure 4.1** Turbulence

Kinematics explains the flow disregarding the forces that causes the flow and dynamics address the flow together with the forces that makes fluid to flow.

Fluids usually flow down an elevation or in the direction of the pressure drop. For example water from a tank placed above the ground will provide a constant flow at ground level until the tank empties. This is due the conversion of potential energy stored at the higher elevation into kinetic energy. However, if a pressure is applied (as in using a pump) water can be pumped up into the tank against the gravity.

In such flows two different flow regimes can be observed. The violently mixing flow is aptly named as “turbulent flow” and gentle, layer like flow is called “laminar flow”. In following sections we discuss the ideas that explain flow in general and how to quantify the flow rates.

### 4.1 Velocity field

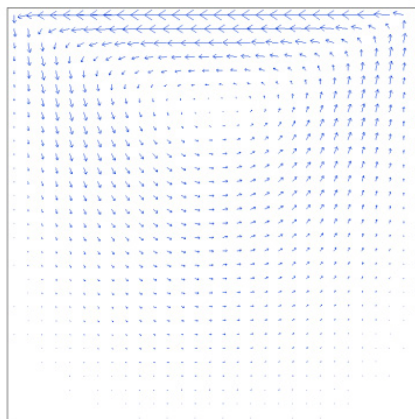

**Figure 4.2.** Velocity vectors

As we discussed earlier, a fluid is a continuous medium. Consider a fluid flowing in a pipe. If you trace the path a small fluid element would take during a period of time you can calculate the average velocity of that particle. If the period of observation is very small, then it gives the instantaneous velocity of the fluid element. Velocity is a vector quantity that has a magnitude and a direction. It could be represented by an arrow pointing towards the direction of the action and a length that corresponds to the magnitude.

Please click the advert

As a leading technology company in the field of geophysical science, PGS can offer exciting opportunities in offshore seismic exploration.

We are looking for new BSc, MSc and PhD graduates with Geoscience, engineering and other numerate backgrounds to join us.

To learn more our career opportunities, please visit [www.pgs.com/careers](http://www.pgs.com/careers)

**A Clearer Image**  
www.pgs.com



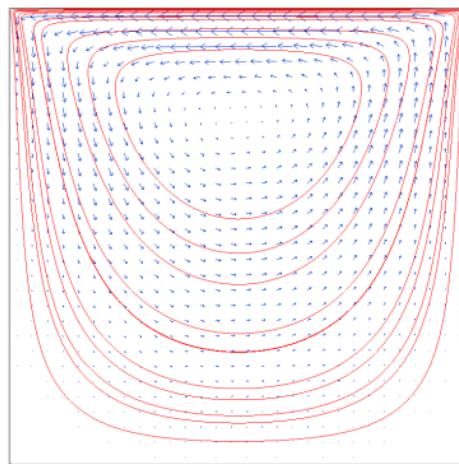

**Figure 4.3** Streamlines with velocity vectors

Fluid that flows consist of a large number of fluid elements that has various velocities. If all the vectors are mapped at a particular moment, it gives a snapshot of the velocity distribution within the flow domain. This velocity vector distribution is called the velocity field.

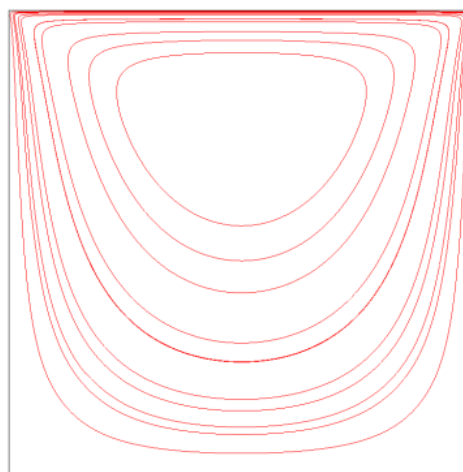

**Figure 4.4.** Streamlines

Figure 4.2 gives an example of such velocity field. It is a flow within a cavity driven by the moving lid at the top. As it can be seen from the figure, the velocity is higher near the moving lid (moving from right to left). The viscosity dissipates the velocity and the corresponding velocity vectors at the bottom, therefore, is represented by smaller arrows.

Velocity field maps provide a method to visualise the flow within any domain.

### 4.1.1 Streamlines

Another important concept in visualising fluid flow is the *streamline*. As discussed above, at any instance a flow field can be represented by the velocity vectors. A line drawn in such a way that it is tangent everywhere to velocity vectors at a given instance is called the streamline. Figure 4.3 shows the family of streamlines for the lid driven cavity discussed in the previous section.

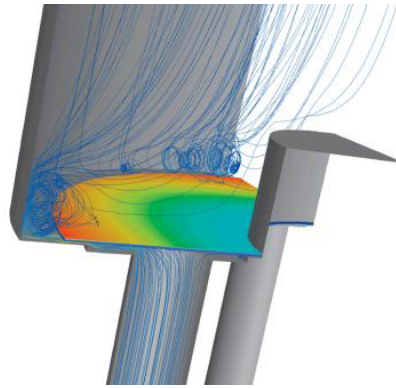

**Figure 4.5.** Pathlines

It is not customary to plot both velocity vectors and the streamlines as they are complimentary. If the flow patterns are the focus then a plot of streamline as shown in figure 4.4 is sufficient. However, if the velocity distribution is the feature one is interested in, then a velocity field map is more relevant.

### 4.1.2 Pathline

*Pathline* is the trajectory of any given fluid particle. It shows the actual path taken by a fluid particle during a given period of time.

Figure 4.5 shows the pathlines of many fluid elements within a shock absorber.



4.1.3 Streakline

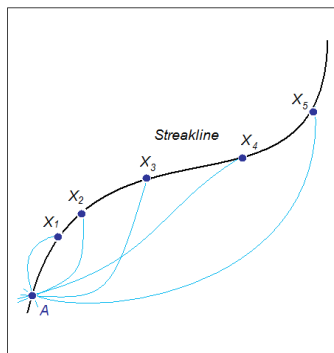

Figure 4.6. Streaklines

Line formed by fluid particles that have earlier passed through a prescribed point is called the *streakline*. For example consider an arbitrary point A in a flow field as shown in Figure 4.6. Particles  $X_1, \dots, X_5$  have passed through the point A at an earlier time. If one take a snapshot at any given moment, and connect all those particles it forms a line. This hypothetical line is called the streakline. Actual paths of the particles can be different from the streakline.

Please click the advert



## Going up in the world...

You'll be going up in the world after graduating from Nottingham Trent University. We are one of the best universities in England for graduate employment with over 97% of our students employed or in further study within six months of graduating.\*

- Consistently ranked as one of the leading modern universities in *The Independent Good University Guide*.
- Courses informed by businesses and industry – strong commercial partnerships with over 6,000 companies globally.
- Many courses include professional accreditation and / or the opportunity to undertake a work placement. This gives our graduates a competitive edge when entering the job market.
- An exciting student city in the middle of England. Ideally located for travel across the UK and with direct flights to destinations across Europe from East Midlands Airport.
- Investing £130 million across our three campuses to create an inspiring learning environment.
- In the most recent QAA institutional review, the University received the highest commendation for its consistent commitment to supporting students and their learning.

If you would like any guidance on applying to Nottingham Trent University please contact Laura Vella, our International Officer for Europe, on

Tel: +44 (0)115 848 8180

Email: [laura.vella@ntu.ac.uk](mailto:laura.vella@ntu.ac.uk)

[www.ntu.ac.uk/book](http://www.ntu.ac.uk/book)

**NOTTINGHAM**  
TRENT UNIVERSITY

5365/07/09

\* HESA DHLE 2006-07

## 4.2 Control volume and system representation

Fluid is a form of matter that is free to “flow”. Fluids as discussed in the first lecture, deforms continuously under applied stress. This flexibility to move around gives rise to various flow patterns that could be visualised using the streamlines, pathlines and streaklines.

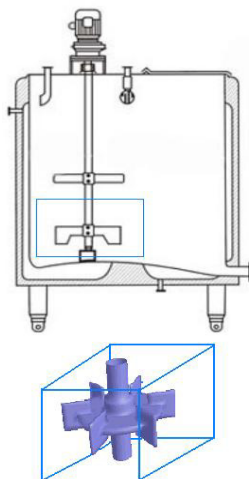

**Figure 4.7(a)** Selection of control volume

Since fluids can flow in space and time, to examine how it behaves, we have to define a specific area in space or a given amount of matter which we would follow. Historically, in analysing the behaviour of fluids, there are two such entities are defined namely *system* and the *control volume*. A system contains a specific, identifiable amount of matter. In most cases, a system might have either a physical or hypothetical boundary containing a mass of matter through which energy and work may transfer. As a system evolve in time the shape and size may change continually but will contain the same mass defined at the beginning. For example, consider a blown up balloon. The air/helium mass inside the balloon remain constant all the time but heat and work can transfer across the rubber membrane which is the boundary of the system.

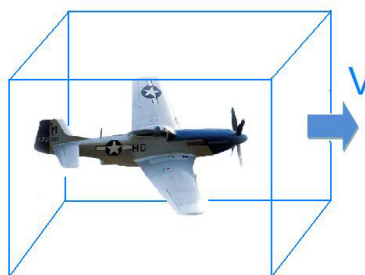

**Figure 4.7(b)** Moving control volume



When analysing fluid flow, we are more concerned about the flow around certain geometries, forces a flow would exert on an object, mixing in a certain region, etc. For such analysis tracing a constant mass of fluid or a system is not practical. Therefore, a specific volume in space can be defined through which fluid can flow. Such a volume defined in space through which fluid may flow with varying mass and volume is called a control volume. Boundary of the control volume is called control surface.

Control volumes could be (a) fixed in space, (b) moving volumes or (c) deforming volumes. For instance in a mixing tank, we can define a fixed control volume encompassing the impeller as shown in Figure 4.7a. If we are to observe the flow distribution around a small aeroplane, as shown in Figure 4.7b, a moving control volume can be defined around the aeroplane. To examine the flow patterns in an engine cylinder one can define a deforming control volume. Figure 4.7c shows the deforming control volume considered in a cylinder.

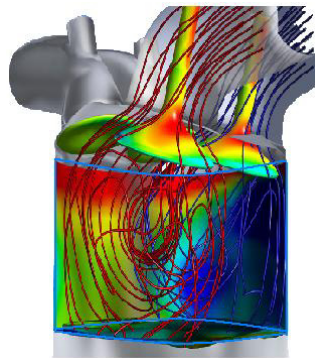

Figure 4.7(c) Deforming Control volume

This lecture series consider fixed control volumes in analysing fluid flow.

### 4.3 Continuity of flow

Consider a pipe with a cross section area  $A$ . A fluid flows through this pipe at a rate  $Q$   $\text{m}^3/\text{s}$ . Suppose the velocity of the fluid across the cross section is  $U$   $\text{m/s}$ . Later we will see that there is a parabolic velocity profile developed in pipes. However  $U$  can be thought of as a mean (or bulk) velocity within the pipe.

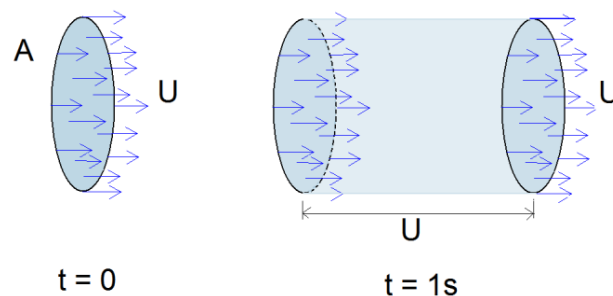

Figure 4.8 Volumetric flowrate

A fluid flowing with the mean velocity  $U$  would extend  $U$  metres during a period of one second. The volume of liquid that has flown through the cross section  $A$  is therefore given by the volume of the cylinder shown in Figure 4.8.

Therefore,

$$Q = UA \quad (4.1a)$$

or 
$$U = Q/A \quad (4.1b)$$

In most chemical engineering applications, volumetric flow rates are specified. Therefore, one can use this simple but useful equation calculate the mean pipe flow velocity.

Einstein's famous equation  $E=mc^2$  suggests that mass can be converted to energy. However, for smaller velocities we are working with, the mass remains constant. In other words it is a conserved quantity. This implies that if accumulation does not happen inside a pipe, the mass that goes in to the pipe should come out of it.

Please click the advert

**STUDY.**  
The stuff you'll need to make a good living

**PLAY.**  
The stuff that makes life worth living

**NORWAY.**  
**YOUR IDEAL STUDY DESTINATION.**

**WWW.STUDYINNORWAY.NO**  
**FACEBOOK.COM/STUDYINNORWAY**

LOOK UP  
STUDY IN  
NORWAY.

Download free ebooks at [bookboon.com](http://bookboon.com)

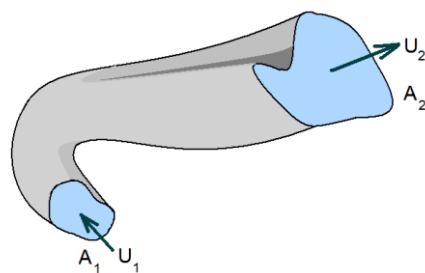

Figure 4.9 Continuity of fluid flow

Consider the flow in a duct shown in Figure 4.9

Mass flow at  $A_1 = \rho A_1 U_1$

Mass flow at  $A_2 = \rho A_2 U_2$

Since the mass is conserved

$$\frac{U_1}{U_2} = \frac{A_2}{A_1} \tag{4.2}$$

**Example**

A pipe A with ID 100mm is connected to a pipe B with ID 65 mm through a converging cone (see figure Q41). Kerosene ( $\rho=800\text{kg/m}^3$ ) is pumped through the pipe. If the average velocity in pipe A is 0.75 m/s, calculate

- a) Velocity in pipe B
- b) Mass flow rate in A
- c) Mass flow rate in B

**Answer**

Concept tested: Continuity of mass flow.

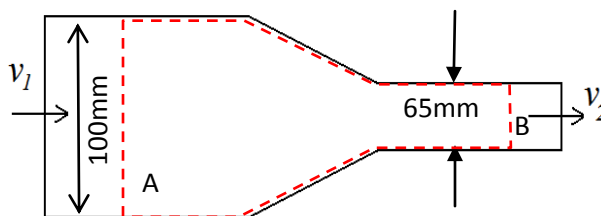

Figure Q4.1 control volume on a converging pipe section

Data given

$$V_1 = 0.75 \text{ m/s}$$

$$\text{Density of kerosene } \rho = 800 \text{ kg/m}^3$$

$$\text{Diameter of pipe A } D = 0.1 \text{ m}$$

$$\text{Diameter of pipe B } d = 0.065 \text{ m}$$

a) Velocity in pipe B

From continuity of mass flow suggest that in the absence of accumulation

$$\text{Mass flow in A} = \text{mass flow in B} \quad (1)$$

Mass flow in A = density  $\times$  volumetric flowrate

$$= \rho \times v_1 \times \frac{\pi D^2}{4} \quad (2)$$

Similarly mass flow in B

$$= \rho \times v_2 \times \frac{\pi d^2}{4} \quad (3)$$

Substituting (2) and (3) in (1)

$$\rho \times v_1 \times \frac{\pi D^2}{4} = \rho \times v_2 \times \frac{\pi d^2}{4}$$

$$v_1 \times D^2 = v_2 \times d^2$$

$$\therefore v_2 = v_1 \times \frac{D^2}{d^2}$$

$$v_2 = 0.75 \times \left[ \frac{0.1}{0.065} \right]^2 = 1.775 \text{ m/s}$$

b) Mass flow rate in A

From equation 3 the mass flowrate in A =

$$\begin{aligned} A &= \rho \times v_1 \times \frac{\pi D^2}{4} \\ &= 800 \times 0.75 \times \frac{\pi (0.1)^2}{4} \\ &= 4.71 \text{ kg/s} \end{aligned}$$

c) Mass flowrate in B = mass flow in A

## 4.4 Types of flow

Observing the general characteristics of fluid flow, several flow types can be identified.

### 4.4.1 Steady flow

Flow velocity at any given point does not change with time. However, velocity can vary in space. For example, consider a pipe with increasing diameter (expansion). Flow within the pipe can be steady with velocity constantly varying along the pipe. Figure 4.10 shows the velocity distribution at several cross sections and the velocity profile along the pipe. The velocity drops due to the increase of the flow area along the axis of the pipe but velocity at each point along the axis does not change with time.

Please click the advert

# Are you considering a European business degree?

**LEARN BUSINESS** at university level. We mix cases with cutting edge research working individually or in teams and everyone speaks English. Bring back valuable knowledge and experience to boost your career.

**MEET** a culture of new foods, music and traditions and a new way of studying business in a safe, clean environment – in the middle of Copenhagen, Denmark.

**ENGAGE** in extra-curricular activities such as case competitions, sports, etc. – make new friends among CBS' 18,000 students from more than 80 countries.

Copenhagen Business School  
HÅNDELSHØJSKOLEN

See what we look like and how we work on [cbs.dk](http://cbs.dk)

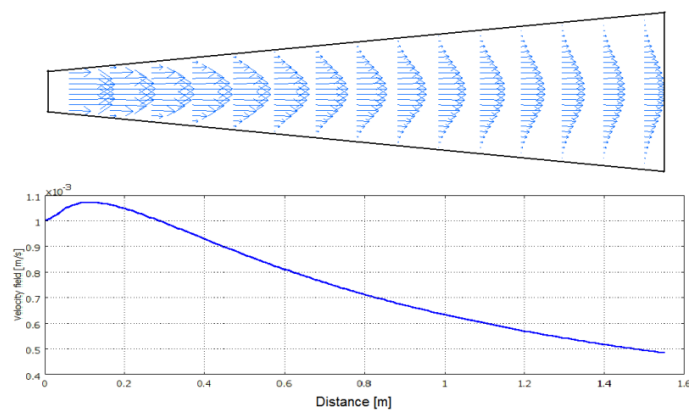

**Figure 4.10.** Velocity variation along a diverging pipe.

#### 4.4.2 Unsteady flow

Velocity of the fluid at any point within the flow domain changes with time. Example of this is the flow in a tea cup just after stirring to dissolve sugar or milk. The flow slows down and eventually come to rest if not disturbed.

#### 4.4.3 Laminar flow

When fluid flows as if they move in parallel layers, it is called a laminar flow. For example, flow in viscous fluid like honey shows laminar flow behaviour. Laminar flow also takes place for less viscous liquids when flow through capillaries or flowing down an inclined plane as a thin film.

#### 4.4.4 Turbulent flow

The most common form of flow is the turbulent flow. The fluid flows while mixing vigorously. Most of the open channel flows, rivers, large diameter pipe flows, blowing wind are common examples for turbulent flows.

### 4.5 Bernoulli equation

We have discussed streamlines in section 3.1.2. Any fluid particle on a streamline will move along the streamline as the velocity of that fluid particle is tangent to the streamline at all points. Fluid particle moving along the stream line may experience acceleration or deceleration due to the forces acting on the particle. If we consider an inviscid fluid at steady state (i.e. velocity at any point does not change with time), there are no shear stresses acting on the particle. Therefore, Newton's second law of motion can be applied to the fluid particle without much difficulty.

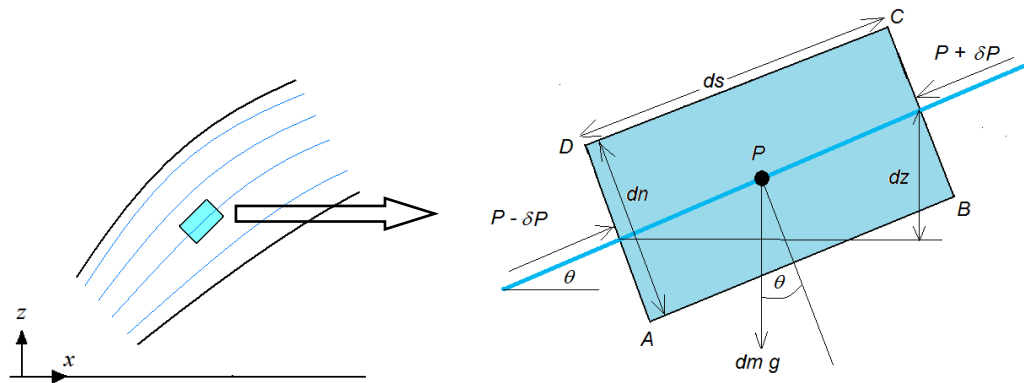

Figure 4.11. Fluid element in a flow

Consider the fluid particle shown in Figure 4.11. The streamline along which the fluid particle moves has an inclination angle  $\theta$ . Length and the width of the fluid particle are  $ds$  and  $dn$  respectively. Pressure at the centre of the element is  $P$ .

Newton's second law of motion states that the force is equal to the rate of change of momentum.

$$\mathbf{F} = \frac{d(mv_2 - mv_1)}{dt} = m\mathbf{a}$$

Where  $\mathbf{a}$  is the acceleration. Consider the forces acting along the streamline on the fluid element. Force due to the pressure  $F_p$

$$\mathbf{F}_p = (P - \delta P)dndy - (P + \delta P)dndy \tag{4.3}$$

$$\delta P = \frac{dP}{ds} \frac{ds}{2} \tag{4.4}$$

Therefore,  $\mathbf{F}_p = -\frac{dP}{ds} dndy ds$  (4.5)

Gravitational force  $F_G$

$$\mathbf{F}_G = -mg \sin \theta = -\rho dndy ds g \sin \theta \tag{4.6}$$

$$\sin \theta = \frac{dz}{ds} \tag{4.7}$$

$$\mathbf{F}_G = -\rho g dndy ds \frac{dz}{ds} \tag{4.8}$$

Therefore, the total force acting on the fluid element  $F_T$  is given by the sum of equations (4.5) and (4.8).

$$\mathbf{F}_T = \mathbf{F}_p + \mathbf{F}_G = -\left(\frac{dP}{ds} + \rho g \frac{dz}{ds}\right) dndy ds \tag{4.9}$$



By applying Newton's second law

$$-\left(\frac{dP}{ds} + \rho g \frac{dz}{ds}\right) dndsdy = \rho(dndsdy) a \tag{4.10}$$

Acceleration  $a$  can be written as  $\frac{dv}{dt}$

$$\frac{dv}{dt} = \frac{dv}{ds} \frac{ds}{dt} = v \frac{dv}{ds} = \frac{1}{2} \frac{dv^2}{ds} \tag{4.11}$$

Therefore, from (d) and (e)

$$-\left(\frac{dP}{ds} + \rho g \frac{dz}{ds}\right) = \rho \frac{1}{2} \frac{dv^2}{ds} \tag{4.12}$$

Integration gives

$$P + \frac{\rho v^2}{2} + \rho g z = E \tag{4.13a}$$

This is known as the *Bernoulli equation* after famous Dutch-Swiss mathematician Daniel Bernoulli.  $E$  on the right hand side of the equation is a constant arising from the indefinite integration.

Rearranging terms to get the traditional form of the equation gives

Please click the advert



## Technical training on *WHAT* you need, *WHEN* you need it

**At IDC Technologies we can tailor our technical and engineering training workshops to suit your needs. We have extensive experience in training technical and engineering staff and have trained people in organisations such as General Motors, Shell, Siemens, BHP and Honeywell to name a few.**

Our onsite training is cost effective, convenient and completely customisable to the technical and engineering areas you want covered. Our workshops are all comprehensive hands-on learning experiences with ample time given to practical sessions and demonstrations. We communicate well to ensure that workshop content and timing match the knowledge, skills, and abilities of the participants.

We run onsite training all year round and hold the workshops on your premises or a venue of your choice for your convenience.

**For a no obligation proposal, contact us today at [training@idc-online.com](mailto:training@idc-online.com) or visit our website for more information: [www.idc-online.com/onsite/](http://www.idc-online.com/onsite/)**

OIL & GAS  
ENGINEERING

ELECTRONICS

AUTOMATION &  
PROCESS CONTROL

MECHANICAL  
ENGINEERING

INDUSTRIAL  
DATA COMMS

ELECTRICAL  
POWER

Phone: +61 8 9321 1702  
 Email: [training@idc-online.com](mailto:training@idc-online.com)  
 Website: [www.idc-online.com](http://www.idc-online.com)





$$\frac{P}{\rho g} + \frac{v^2}{2g} + z = E \quad (4.13b)$$

## 4.6 Physical meaning of the Bernoulli equation

Each term in the l.h.s of the equation (4.13b) is called a “head”.

$$\frac{P}{\rho g} = \text{Pressure head}$$

$$\frac{v^2}{2g} = \text{Velocity head}$$

$$z = \text{Elevation head}$$

Consider the elevation head. It has the dimensions of length: meters. Since the equation (4.13b) obeys dimensional homogeneity, other two terms too have dimensions of length.

Head is a measure of energy per unit weight of the fluid. For example, a fluid volume with mass  $m$  elevated to a height of  $h$  above the ground has a potential energy  $mgh$  (units: Joules). In this case, ground is considered as the reference level with zero potential energy. If we compute the energy per unit weight, it gives  $h$ . The elevation head in equation (4.13b) can be considered as the height above some reference level which is often called the “Datum level”.

Similarly pressure head gives the energy due to pressure force and velocity head gives the kinetic energy of a unit weight of the fluid. In this sense, Bernoulli equation gives a simpler form of energy conservation. Inviscid fluids are absent of energy dissipating mechanism called viscous dissipation. Since there is no energy dissipation, equation (4.13b) suggests that the total head of a fluid element remains a constant as it flows along the streamline.

Consider a fluid element initially at location 1,  $z_1$  above the datum flow along the streamline to location 2 gaining a height  $z_2$  above the datum as shown in Figure 4.12. Consider the total head at 1 to be  $E_1$  and at 2 to be  $E_2$ .

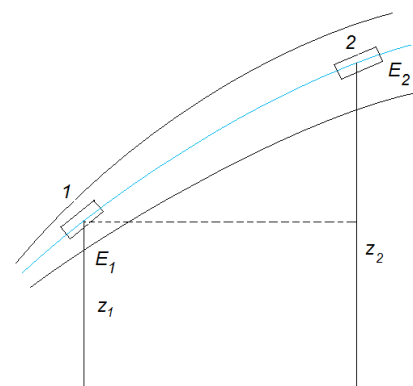

**Figure 4.12.** Application of Bernoulli equation

Since  $E_1 = E_2$

$$\frac{P_1}{\rho g} + \frac{v_1^2}{2g} + z_1 = \frac{P_2}{\rho g} + \frac{v_2^2}{2g} + z_2 = E \quad (4.14)$$

## 4.7 Applications of Bernoulli equation

Even though Bernoulli equation is derived for inviscid fluids, it provides a good estimation for real fluids when the viscosity is small. This flexibility gives a wide variety of applications especially in flow velocity measurements. Equation (4.14) can be applied to two locations within the flow. If five of the six variables are known, then the unknown could easily be determined.

Here we consider several applications of the Bernoulli equation.

### 4.7.1 Free jets

A free jet forms when a liquid accelerates through a nozzle. Consider a nozzle at the bottom of a reservoir as shown in Figure 4.13. The smooth and well contoured nozzle has a diameter  $d$ .

Consider a fluid element moving from (1) at the surface to (2) at the nozzle exit along the streamline. The free surface of the liquid is  $h$  distance above the nozzle.

Assuming the datum is at the nozzle, applying Bernoulli equation between (1) and (2) gives

$$\frac{P_1}{\rho g} + \frac{v_1^2}{2g} + h = \frac{P_2}{\rho g} + \frac{v_2^2}{2g}$$

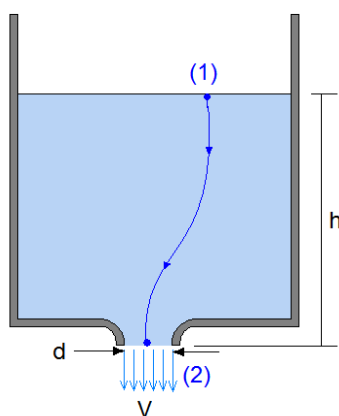

Figure 4.13 Free jet

Both (1) and (2) are at atmospheric pressure. Therefore,  $P_1 = P_2$ . If the gage pressure is used, this assumes the value zero.

Furthermore, compared to the nozzle diameter, the diameter of the reservoir is large. As a result the velocity at (1) is insignificant compared to the velocity at the nozzle. These assumptions further simplify the Bernoulli equation.

$$h = \frac{V^2}{2g}$$

Therefore the velocity at the nozzle is given by

$$V = \sqrt{2hg} \quad (4.15)$$

This means that given the liquid level in the reservoir, the exit velocity at the nozzle can be determined. This equation holds when the nozzle is smooth and properly contoured.

It is common to have orifices on the vertical side walls of tanks as outlets. Most of these are not well contoured smooth nozzles. Consider a nozzle as shown in Figure 4.14. It is a hole on a flat plate with diameter  $d_o$ . Static pressure varies across the orifice as the depth changes. However, the velocity at the centre line can be considered as the average velocity if  $d_o \ll h$  where  $h$  is the liquid height above the centreline of the orifice.

Please click the advert

[www.studyat.tudelft.nl](http://www.studyat.tudelft.nl)

- Ranked #15th in the world (THES Technology ranking 2009)
- Almost 170 years of problem solving experience
- Excellent Sports&Culture facilities
- Check out what and how we teach at [www.ocw.tudelft.nl](http://www.ocw.tudelft.nl) !

**TU Delft** Delft University of Technology  
Challenge the future

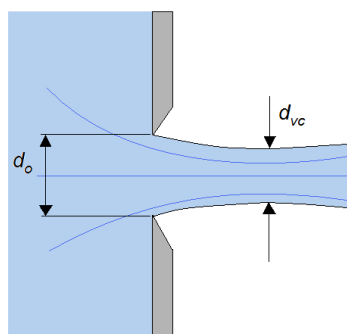

Figure 4.14. Vena Contracta

Fluid streamlines cannot change direction abruptly. When the fluid elements takes the 90 degree angle passing through the orifice follows a path that creates a jet diameter less than the orifice diameter. This thinning that occurs downstream just outside the orifice is called *Vena Contracta*.

Applying Bernoulli equation between two points at the surface ( $p_1, v_1, h_1$ ) and the *vena contracta* ( $p_2, v_2, h_2$ )

$$\frac{P_1}{\rho g} + \frac{v_1^2}{2g} + h_1 = \frac{P_2}{\rho g} + \frac{v_2^2}{2g} + h_2$$

Velocity  $v_1$  at the surface far away from the orifice is negligible. Both  $P_1$  and  $P_2$  are equal to the atmospheric pressure. By selecting the datum along the centreline of the orifice  $h_2$  can be eliminated from the equation. Suppose the liquid height  $h_1 = h$ .

This gives the velocity at the vena contracta as

$$v_2 = \sqrt{2hg} \quad (4.16)$$

In this argument, we consider the fluid to be ideal; i.e. frictionless. But in reality the liquid has a viscosity dissipating energy. Furthermore, the surface tension effects are also neglected. Both these concepts result in reducing the velocity. As a result the actual velocity at the vena contracta is less than  $\sqrt{2gh}$ . To correct this over prediction a correction factor,  $C_v$  called *coefficient of velocity* is used.

$$\text{Coefficient of velocity } C_v = \frac{\text{Actual velocity at the orifice}}{\text{Ideal velocity}} \quad (4.17)$$

$$\text{Therefore actual velocity} = C_v \sqrt{2hg} \quad (4.18)$$

As we discussed above, vena contracta is the thinnest diameter of the liquid jet. This is often given as a function of the orifice diameter by defining another coefficient called *coefficient of contraction*,  $C_c$

$$C_c = \frac{\text{Area of the Vena Contracta } , A_{vc}}{\text{Area of the orifice } , A_o} \quad (4.19)$$

Both, friction and the formation of the vena contracta affect the discharge through the orifice. The estimate using the Bernoulli equation based on ideal fluid disregarding the contraction gives a rather higher value than the actual discharge. As before, to correct this over estimation, a correction factor is introduced. *Coefficient of discharge*,  $C_d$  is defined as the ratio between the actual and ideal discharges.

$$C_d = C_c \times C_v \quad (4.20)$$

Assume the discharge at the vena contracta to be  $Q$ .

$$\begin{aligned} Q &= A_{vc} \times v_2 = C_c A_o \times C_v \sqrt{2gh} \\ &= C_c C_v A_o \sqrt{2gh} = C_d A_o \sqrt{2gh} \end{aligned}$$

Therefore the actual discharge through the orifice is given by

$$Q = C_d A_o \sqrt{2gh} \quad (4.21)$$

Coefficient of discharge for some nozzle types is shown in Figure 4.15.  $C_c$ ,  $C_v$ , and  $C_d$  are determined experimentally.

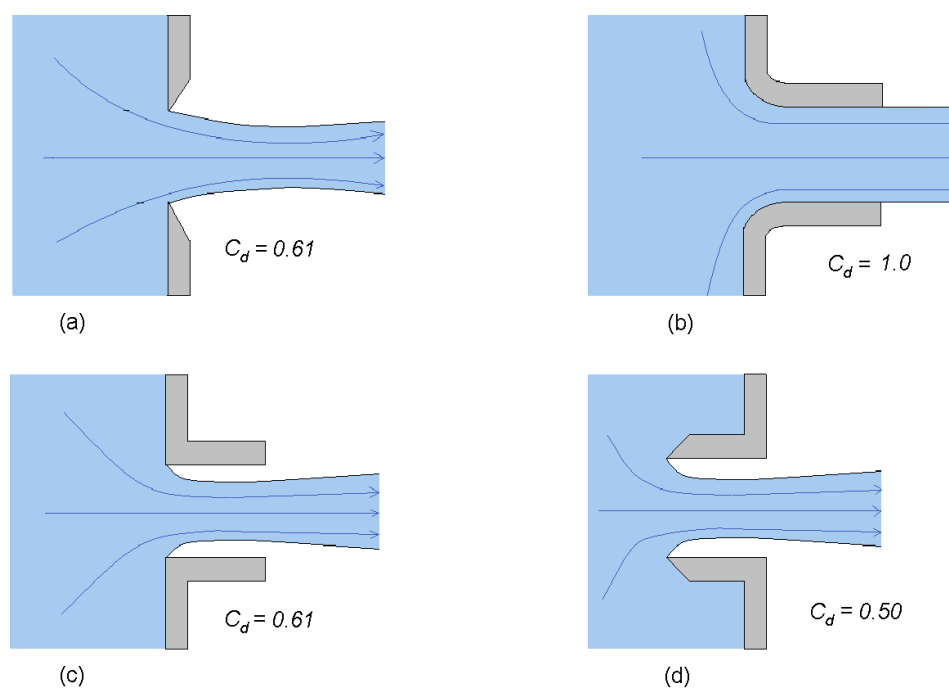

**Figure 4.15** Discharge coefficients for some nozzle types

*Exercise**Starting from the definition, prove  $C_d = C_c \times C_v$* 

## 4.7.2 Flowrate measurements

Controlling flowrates is the key to optimise a chemical plant. Therefore, measuring flowrates is an important. There are several types of flow meters. Some are based on travel of an acoustic wave in a flowing fluid; some are using force exerted on an immersed body. There is another category that uses Bernoulli principle to measure flow rates within pipes. They are

## Study at one of Europe's leading universities



Please click the advert

DTU, Technical University of Denmark, is ranked as one of the best technical universities in Europe, and offers internationally recognised Master of Science degrees in 39 English-taught programmes.

DTU offers a unique environment where students have hands-on access to cutting edge facilities and work

closely under the expert supervision of top international researchers.

DTU's central campus is located just north of Copenhagen and life at the University is engaging and vibrant. At DTU, we ensure that your goals and ambitions are met. Tuition is free for EU/EEA citizens.

Visit us at [www.dtu.dk](http://www.dtu.dk)



Download free ebooks at [bookboon.com](http://bookboon.com)

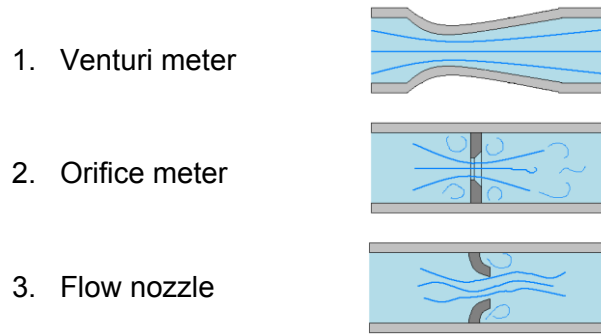

Venturi meter

When a fluid flow through a constriction, as the Bernoulli equation implies, velocity increases at the expense of pressure. This is known as the venturi effect (named after the Italian physicist Giovanni Battista Venturi). By measuring the pressure drop, the flow velocity can be determined. Since the pipe diameter is known, the flowrate can easily be deduced. Venturi meters could easily be integrated into any piping system. It has a pipe section that matches the diameter of the piping system and a shorter contraction and a longer expansion as shown in Figure 4.16. A manometer is fitted to two tapings, one before the contraction and the other at the point where the pipe produces the smallest diameter. Suppose the manometer fluid density is  $\rho_{man}$ . Other parameters are shown in Figure 4.16.

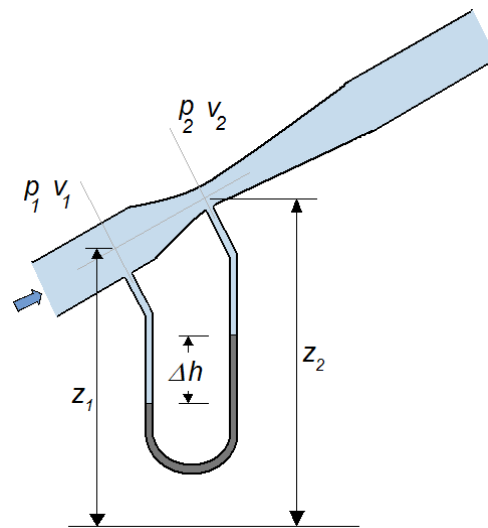

Figure 4.16. Venturi meter

Applying the Bernoulli equation between the two points

$$\frac{P_1}{\rho g} + \frac{v_1^2}{2g} + z_1 = \frac{P_2}{\rho g} + \frac{v_2^2}{2g} + z_2 \tag{a}$$

Considering the continuity of flow,

$$v_1 A_1 = v_2 A_2 \quad (b)$$

where  $A_1$  and  $A_2$  are the cross sectional area of the pipe and the venture respectively. By substituting (b) in (a) and rearranging, an expression for the velocity at the throat of the venture meter can be obtained.

$$v_2 = \sqrt{\frac{2A_1^2[(P_1 - P_2) + \rho g(z_1 - z_2)]}{\rho(A_1^2 - A_2^2)}} \quad (c)$$

Flowrate  $Q$  is given by

$$Q = v_2 A_2 \quad (d)$$

Therefore, by substituting (c) in (d)

$$Q = A_1 A_2 \sqrt{\frac{2[(P_1 - P_2) + \rho g(z_1 - z_2)]}{\rho(A_1^2 - A_2^2)}} \quad (e)$$

In reality, there will be friction losses and the velocity  $v_2$  is less than the theoretical value given by equation (c). To correct this over estimation, a correction factor is introduced. This is similar to the discharge coefficient in the previous section. Therefore,

$$Q = C_d A_1 A_2 \sqrt{\frac{2[(P_1 - P_2) + \rho g(z_1 - z_2)]}{\rho(A_1^2 - A_2^2)}} \quad (4.22)$$

where  $C_d$  is a discharge coefficient. Typically  $C_d = 0.98$ .

Suppose the difference of heights in the manometer columns is  $\Delta h$ .

$$P_1 - P_2 = \Delta h \rho_{man} g$$

Substituting  $\Delta h \rho_{man} g$  for  $(P_1 - P_2)$  the flowrate can easily be measured.  $\rho_{man}$  is the density of the manometer fluid.

### Orifice meter and flow nozzle

Venturi meter is designed to create a measureable pressure drop so that the flow rate could be measured. Similar result can be achieved by inserting an orifice plate. Orifice plate has a sharp edged opening smaller than the internal diameter of the pipe at the centre. This is a cheaper application than the venture meter but dissipate a larger amount of energy giving a larger pressure drop. Flow nozzle is similar to the orifice plate but designed to reduce the energy dissipation.

Equation (4.22) is applicable to both, orifice meter and flow nozzle. However, they have different discharge coefficients. For the orifice meter where the losses are high,  $C_d = 0.65$  is widely used. For flow nozzles, on average  $C_d = 0.95$  seems to be appropriate.



### 4.7.3 Static, Dynamic, and Stagnation Pressure

In previous section, we used Bernoulli equation to determine the flowrate in pipes. We achieved this by creating a measurable pressure difference between two points in the pipe. Similarly, as Bernoulli equation relates pressure head and velocity head, if the velocity head can be measured then the pressure in a pipeline can be determined. Pressure is a quantity defined according to the force exerted by a liquid on surfaces. As a result there are several types of pressure defined in flow fields. This could be understood easily by considering pressure as a form of energy. Pressure is measured in Pascal. Units suggest that pressure is indeed the energy of the fluid per unit volume.

$$Pa = \frac{N}{m^2} = \frac{Nm}{m^3} = \frac{J}{m^3}$$

This is consistent with the other terms in the Bernoulli equation

$$P + \frac{\rho v^2}{2} + \rho g z = E$$

Please click the advert



## MSM

### Maastricht School of Management

Increase your impact with MSM Executive Education





For almost 60 years Maastricht School of Management has been enhancing the management capacity of professionals and organizations around the world through state-of-the-art management education.

Our broad range of Open Enrollment Executive Programs offers you a unique interactive, stimulating and multicultural learning experience.

**Be prepared for tomorrow's management challenges and apply today.**

For more information, visit [www.msm.nl](http://www.msm.nl) or contact us at +31 43 38 70 808 or via [admissions@msm.nl](mailto:admissions@msm.nl)

the globally networked management school

As fluid flows the energy could transform to various forms that contribute to pressure.  $P$  in above equation is the actual thermodynamic pressure as it flows. It is the pressure exerted by the molecules on the surrounding due to the molecular motion. To measure this pressure, the observer has to move at the velocity of the bulk flow. Hence it is called the *static pressure*. Alternatively, one can measure static pressure by connecting a pressure gauge (or a manometer) to a tapping normal to the flow.

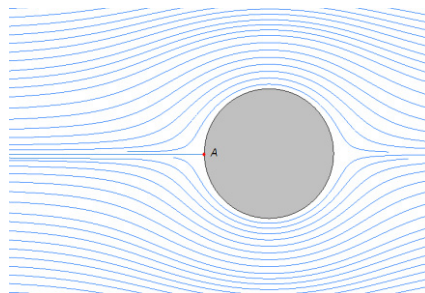

**Figure 4.17.** stagnation point on a sphere immersed in a stream

Consider a flow around a body immersed in the fluid as shown in Figure 4.17. Fluid that flows from left to right go around the Sphere. Since fluid flow past around the body there is a point where velocity becomes zero. The stream line that reaches this point terminates there. It is shown as the point A in Figure 4.17. Such points where fluid velocity becomes zero are called stagnation points. Consider the stream line that ends at A. A fluid element far away from A has a total energy  $P + \frac{1}{2}\rho v^2$ . At point A,  $v=0$ , therefore the kinetic energy disappears. Since the total energy has to remain constant (as Bernoulli equation suggests), pressure at A has to gain  $\frac{1}{2}\rho v^2$  giving pressure at A,  $P_A = P + \frac{1}{2}\rho v^2$ . This is known as the *stagnation pressure* of that stream line. The streamline ending at A is called the stagnation streamline.

The term  $\frac{1}{2}\rho v^2$ , which gives the pressure due to fluid motion is called the *dynamic pressure*.

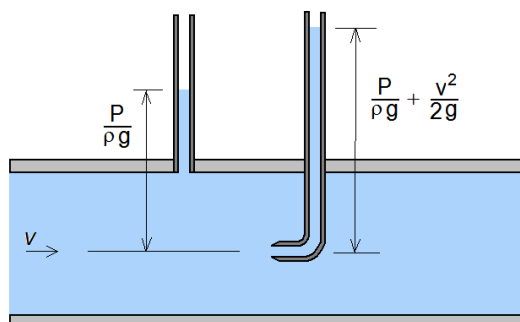

**Figure 4.18** static and dynamic pressures

Figure 4.18 shows the static and stagnation pressure as liquid heights. The tapping at the boundary (wall of the pipe in this case) is normal to the flow. Therefore, it does not “feel” the kinetic energy. As a result, it reads only the static pressure. In the second case where a bent tube is inserted in to the pipe with the opening facing the flow, formation of a stagnation point can be observed at the nozzle. As a result the liquid column gives the stagnation pressure. This phenomenon is used to measure the flow velocity.

#### 4.7.4 Pitot tube

Pitot tube, named after the inventor -French hydraulics engineer Henry Pitot, is used to measure the flow velocity using the stagnation pressure. This is widely used in aeroplanes to measure air speed.

Consider Figure 4.19. Assume a fluid particle that moves along the stream line that forms a stagnation point at the impact hole of the second tube. Velocity at the upstream is  $v$ .

Then from the Bernoulli equation

$$\frac{P_1}{\rho g} + \frac{v^2}{2g} = \frac{P_2}{\rho g} \quad (a)$$

$$v = \sqrt{2 \left( \frac{P_2 - P_1}{\rho} \right)} \quad (b)$$

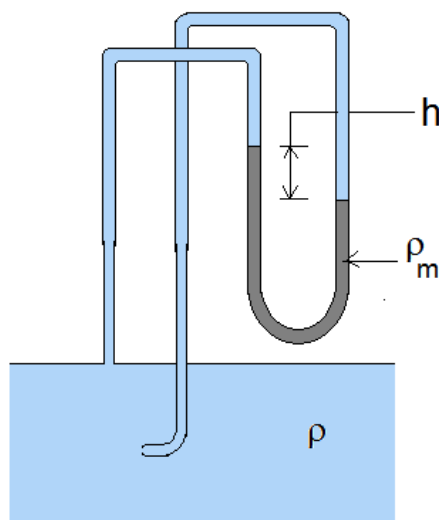

Figure 1.19 Pitot tube

Consider a manometer connected to the two ends of the tubes. Assume the density of the manometer fluid as  $\rho_m$ . The height difference between the manometer liquid levels is  $h$ .

$$P_1 - P_2 = h\rho_m g \quad (c)$$

By substituting (c) in (b)

$$v = \sqrt{2 \left( \frac{hg(\rho_m - \rho)}{\rho} \right)} \quad (4.23)$$

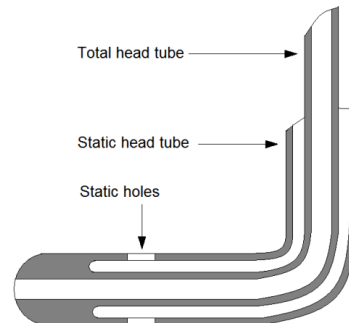

Figure 4.20. Details of the Pitot tube probe

In actual design, instead of two separate tubes that needs two tapings on the pipe, a single coaxial pipe arrangement is used. Figure 4.20 shows a typical Pitot tube used to measure flow velocity.

Please click the advert

What do the telephone handset and  
the refrigerator have in common with  
the pacemaker and the computer mouse?

They are all  
Swedish inventions  
used every day worldwide.

Challenge Yourself – Study in Sweden

[www.studyinsweden.se](http://www.studyinsweden.se)

## Example

Consider a fluid with density  $800 \text{ kgm}^{-3}$ .

1. This fluid is placed in a 5 mm gap between two parallel plates. Top plate is moved with a constant velocity  $0.25 \text{ ms}^{-1}$  over the fixed bottom plate. It is found that the top plate experience a force  $0.125 \text{ Nm}^{-2}$ . Determine the kinematic viscosity of the fluid.
2. Same fluid is flowing in a pipe. The pipe diameter is 200 mm. A Pitot tube with an external manometer is connected to the pipe. The manometer fluid is water. The height difference between the water levels in the two legs is 33 mm.
  - a) Calculate the volumetric flowrate in the pipe.
  - b) Calculate the Reynolds number of the pipe flow.

## Answer

Determining the kinematic viscosity

Flow configuration described in the question is shown in figure Q4.2.

According to the Newton's law on fluid shear stress,

$$\tau = \frac{F}{A} = \mu \frac{du}{dy} \text{----- (1)}$$

where  $\mu$  is the viscosity and  $\frac{du}{dy}$  is the velocity gradient.

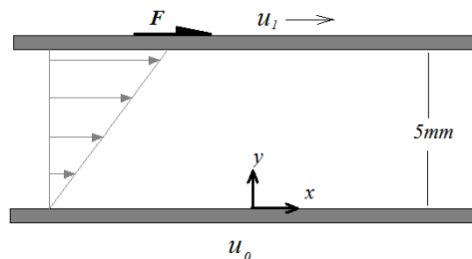

Figure Q4.21

Velocity gradient can be written as

$$\frac{du}{dy} = \frac{\Delta u}{\Delta y} = \frac{u_1 - u_0}{\Delta y} \quad (2)$$

$$\text{Therefore } \tau = \frac{F}{A} = \mu \left( \frac{u_1 - u_0}{\Delta y} \right) \quad (3)$$

It is given that

$$\frac{F}{A} = 0.125 \text{ N/m}^2$$

$$u_1 = 0.25 \text{ m/s}$$

$$u_0 = 0$$

$$\Delta y = 5 \text{ mm}$$

Rearranging equation (3)

$$\mu = \left(\frac{F}{A}\right) \left(\frac{\Delta y}{u_1}\right) \text{----- (4)}$$

Substituting values given  $\mu = 0.125 \times \left(\frac{5}{0.25}\right) = 2.5 \times 10^{-3} \text{ Pa} \cdot \text{s}$

Kinematic viscosity  $\nu = \frac{\mu}{\rho} = \frac{2.5 \times 10^{-3}}{800} = 3.125 \times 10^{-6} \text{ m}^2/\text{s}$

2. (a) Calculating the volumetric flow rate

Diameter of the pipe  $D = 200 \text{ mm}$

The flow rate  $Q = \frac{\pi D^2}{4} U \text{----- (5)}$

where  $U$  is the average velocity.  $U$  has to be determined using the Pitot tube information given.

Applying the Bernoulli equation at planes defined by the Pitot tube openings

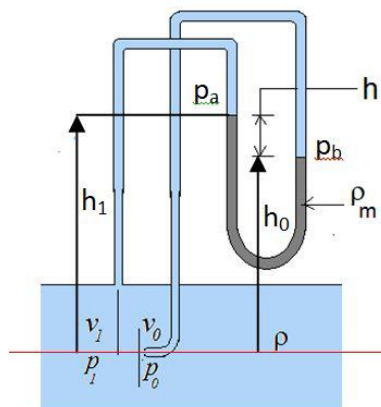

Figure Q4.3

$$\frac{p_1}{\rho g} + \frac{v_1^2}{2g} = \frac{p_0}{\rho g} \text{----- (6)}$$

$$v_1^2 = \frac{2(p_0 - p_1)}{\rho} \text{----- (7)}$$

Using the diagram

$$p_b = p_0 - h_0 \rho g \text{-----(a)}$$

$$p_a = p_1 - h_1 \rho g \text{-----(b)}$$

From (a)-(b)

$$p_b - p_a = p_0 - p_1 + h_1 \rho g - h_0 \rho g$$

$$h \rho_w g = p_0 - p_1 + h \rho g$$

$$p_0 - p_1 = h \rho_w g \left[ 1 - \frac{\rho}{\rho_w} \right] \text{-----(8)}$$

Therefore,

$$v_1 = \sqrt{2hg \left( \frac{\rho_w}{\rho} - 1 \right)} \text{----- (9)}$$

Using equation (9)

$$v_1 = \sqrt{2 \times 0.033 \times 9.81 \left( \frac{1000}{800} - 1 \right)} = 0.40 \text{ m/s}$$

Please click the advert

DESTINATIONS		GATE	ARRIVAL
INDUSTRY	IMPACT	OW	FASTER
GLOBAL	ASSIGNMENTS	OW	FASTER
SENIOR	CLIENT CONTACT	OW	FASTER
CAREER	DEVELOPMENT	OW	FASTER
MAKE	PARTNER	OW	FASTER

 **OLIVER WYMAN**



Oliver Wyman is a leading global management consulting firm that combines deep industry knowledge with specialized expertise in strategy, operations, risk management, organizational transformation, and leadership development. With offices in 50+ cities across 25 countries, Oliver Wyman works with the CEOs and executive teams of Global 1000 companies.  
An equal opportunity employer.

**GET THERE FASTER**

Some people know precisely where they want to go. Others seek the adventure of discovering uncharted territory. Whatever you want your professional journey to be, you'll find what you're looking for at Oliver Wyman.

Discover the world of Oliver Wyman at [oliverwyman.com/careers](https://oliverwyman.com/careers)



From (5) the volumetric flow rate

$$Q = \frac{\pi D^2}{4} U = \frac{\pi \times 0.2^2}{4} \times 0.4 = 0.0126 \text{ m}^3/\text{s}$$

## 4.8 Linear Momentum

When a given mass  $m$  moves at a velocity  $v$ , the momentum of the moving mass is given by the product between mass and the velocity  $mv$ . Momentum is a vector quantity that has a magnitude and a direction. Flow moves mass fluid at a given velocity. Therefore, fluids on motion carry the momentum with it. According to Newton's second law, rate of change of momentum gives the force applied on the mass.

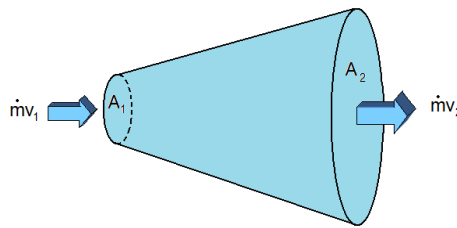

**Figure 4.21.** Momentum transfer in a control volume

Consider a control volume shown in Figure 4.21. At the inlet the momentum is  $\dot{m}v_1$  and at the outlet the momentum is  $\dot{m}v_2$ . Since the two velocities are different, the momentum values are different. Therefore, the force applied by the fluid on the control volume is given by the difference.

$$F = \dot{m}v_2 - \dot{m}v_1 \quad (4.24)$$

The mass flowrate can be calculated by multiplying the volumetric flowrate by the density of the fluid. Since the momentum is a vector quantity it could be resolved into perpendicular directions. This provides a means to account for all forces applied by a fluid on bends of pipes.

### 4.8.1 Force applied by a liquid jet impinging on a flat plate

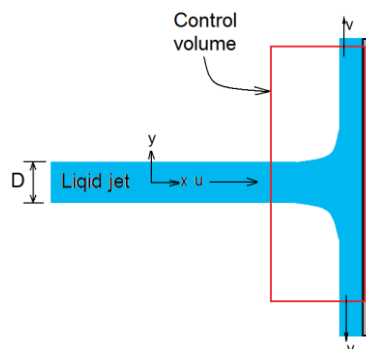

**Figure 4.22.** Jet impinging on a wall



Consider a horizontal liquid jet impinging on a vertical wall as shown in Figure 4.22. The jet velocity is  $u$  and the diameter of the jet is  $D$ . The mass flowrate of the jet is

$$\dot{m} = \rho \frac{\pi D^2}{4} u \quad (4.25)$$

Consider a control volume that contains the impingement point as shown in Figure 4.22.

The momentum of the jet that enters the control volume in  $x$  direction is given by

$$\dot{m}u = \rho \frac{\pi D^2}{4} u^2 \quad (4.26)$$

The liquid spreads as it impinge on the plate. The velocity in  $x$  direction at the wall is zero and the velocity in  $+y$  and  $-y$  direction are equal and has a magnitude  $v$ . Therefore, the momentum leaving the control volume in  $x$  direction is zero. The net change of momentum across the control volume in  $x$  direction gives the force acting on the flow direction.

$$F_x = 0 - \dot{m}u = 0 - \rho \frac{\pi D^2}{4} u^2 = -\rho \frac{\pi D^2}{4} u^2 \quad (4.27)$$

The force act on the control volume is in  $-x$  direction. An equal and opposite force is applied on the wall by the jet. Therefore, the force on the wall in positive  $x$  direction is

$$F_x = \rho \frac{\pi D^2}{4} u^2 \quad (4.28)$$

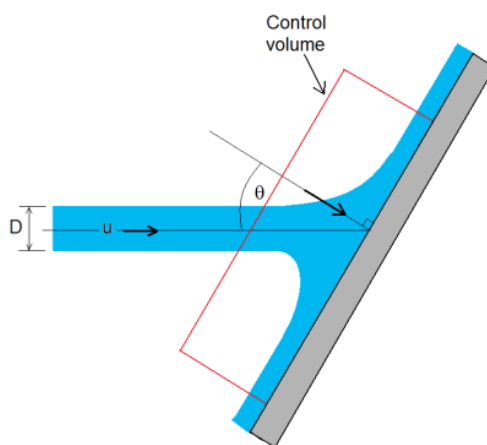

**Figure 4.23.** Jet impinging at an angle on a plate

Consider the plate inclining at an angle  $\theta$  to the jet. The force on the plate can be resolved to two components along the plate and normal to the plate. The velocity normal to the plate is  $u \cos\theta$ . Therefore, the magnitude of the force the jet exerts normal to the plate is

$$F = \rho \frac{\pi D^2}{4} u^2 \cos\theta \quad (4.29)$$

### 4.8.2 Force on a pipe bend

A more important application the linear momentum is the force acting on a bend of a pipe. Consider a converging bend with an angle  $\theta$  as shown in Figure 4.24. Pressure and velocity at the inlet is  $p_1$  and  $u_1$  respectively. Diameter of the inlet is  $d_1$  and the cross sectional area is  $A_1$ . The same parameters at the outlet are given with the subscript 2. The mass entering the system is  $\dot{m}$ . The control volume is marked by the inside of the pipe and the inlet and outlet. The force acting on the fluid is due to many factors. The pressure at the inlet and outlet apply forces on the fluid within the control volume. The pipe wall applies a force on the fluid and the gravity acts on the fluid mass.

Pressure at the inlet applies a force normal to the surface in the direction of the flow. Similarly pressure at the outlet applies a force normal to the outlet surface in the opposite direction to the flow. The force due to the wall arise from the momentum change

Please click the advert

**Day one**  
and you're ready

Day one. It's the moment you've been waiting for. When you prove your worth, meet new challenges, and go looking for the next one. It's when your dreams take shape. And your expectations can be exceeded. From the day you join us, we're committed to helping you achieve your potential. So, whether your career lies in assurance, tax, transaction, advisory or core business services, shouldn't your day one be at Ernst & Young?

**What's next for your future?**  
[ey.com/careers](http://ey.com/careers)

**ERNST & YOUNG**  
Quality In Everything We Do

© 2010 EYGM Limited. All Rights Reserved.

Download free ebooks at [bookboon.com](http://bookboon.com)

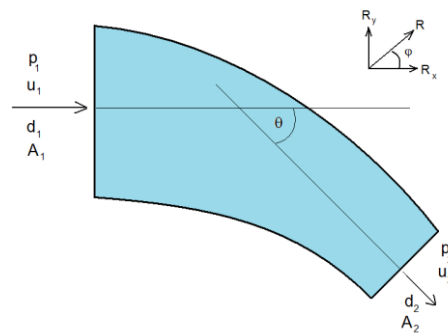

**Figure 4.24.** Force at a bend

Let the total force acting in the x direction is  $R_x$ .

$$R_x = p_1 A_1 - p_2 A_2 \cos \theta - \dot{m}(u_2 \cos \theta - u_1) \quad (4.30)$$

The total force in y direction is  $R_y$ . Then,

$$R_y = p_2 A_2 \sin \theta - \dot{m}g + \dot{m}(u_2 \sin \theta) \quad (4.31)$$

The resultant force is given by

$$R = \sqrt{R_x^2 + R_y^2} \quad (4.32)$$

And the inclination angle of R to the x axis is given by

$$\varphi = \tan^{-1} \left( \frac{R_y}{R_x} \right) \quad (4.33)$$

### Example

A water jet is used at a carwash is created by connecting a nozzle to a hose as shown in figure 3. The pressure at the entry section is 250kPa and the flowrate is 1liter/s. The entry section diameter is 25mm and the exit section diameter is 10mm. Determine the anchoring force required to hold the nozzle.

### Answer

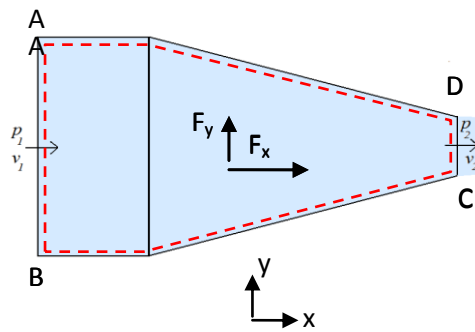

Figure Q4.4

This question tests the ability to apply the rate of change of momentum to a flow nozzle. The velocity changes inside the converging nozzle. As a result the momentum changes continuously. Therefore, the walls appear to apply a force on the fluid defined within the control volume. Unless there is an equal and opposite force to anchor the nozzle, it would move. This is what happens when a tap connected to a freely lying garden hose opens.

Define a control volume as shown in the figure.

Data given

Pressure of water at the entry plane	$p_1 = 250\text{kPa}$
Pressure at the exit plane	$p_2 = 1 \text{ atm}$
Flowrate in the hose	$q = 1\text{litre/s}$
Entry section diameter	$d_1 = 25 \text{ mm}$
Exit nozzle diameter	$d_2 = 10 \text{ mm}$

We are to determine the anchoring force.

In x direction

Pressure force acting on the cross section AB =  $p_1 A_1$

Since the atmospheric pressure is the reference there is no force on DC

Assume the force acting on the control volume in x direction is  $F_x$

Momentum change in x direction =  $mv_2 - mv_1$

Therefore, the total momentum change in x direction should be equal to all the forces acting on the control volume in the same direction.

$$mv_2 - mv_1 = F_x + p_1 A_1 \quad (1)$$

In y direction there are no forces appearing due to momentum change or pressure.

$$F_y = 0 \quad (2)$$

Velocity at AB  $v_1 = \text{flowrate}/\text{Cross sectional area}$  1 litre water =  $0.001\text{m}^3$

$$= 0.001 / (0.25 \times \pi \times 0.025^2)$$

$$= 2.04 \text{ m/s}$$

Velocity at CD  $v_2 = 0.001 / (0.25 \times \pi \times 0.01^2)$

$$= 12.73 \text{ m/s}$$

Mass flow rate  $m = 1 \text{ kg/s}$       1 litre water = 1 kg

From equation (1),

$$m(v_2 - v_1) = F_x + p_1 A_1$$

$$1 \times (12.73 - 2.04) = F_x + 250 \times 1000 \times (0.25 \times \pi \times 0.025^2)$$

$$F_x = -122.72 \text{ N}$$

The negative sign indicates that the force is opposite to the flow direction (positive x).

Therefore the anchoring force required is 122.72N in the positive x direction

## References

1. Douglas, J.F., Gasiorek, J., Swaffield, J., and Jack, L., Fluid Mechanics 6<sup>th</sup> Ed., Prentice Hall, 2011.
2. White, F.M., Fluid Mechanics, 7<sup>th</sup> Ed. McGraw-Hill, 2011.
3. Robert W. Fox, R.W., McDonald, A.T. and Pritchard P.J., Introduction to Fluid Mechanics, 7th Ed, 2005.

Please click the advert



Hellmann's is one of Unilever's oldest brands having been popular for over 100 years. If you too share a passion for discovery and innovation we will give you the tools and opportunities to provide you with a challenging career. Are you a great scientist who would like to be at the forefront of scientific innovations and developments? Then you will enjoy a career within Unilever Research & Development. For challenging job opportunities, please visit [www.unilever.com/rdjobs](http://www.unilever.com/rdjobs).

Could it be   
Unilever



# 5 Laminar and Turbulent Flow

## Introduction

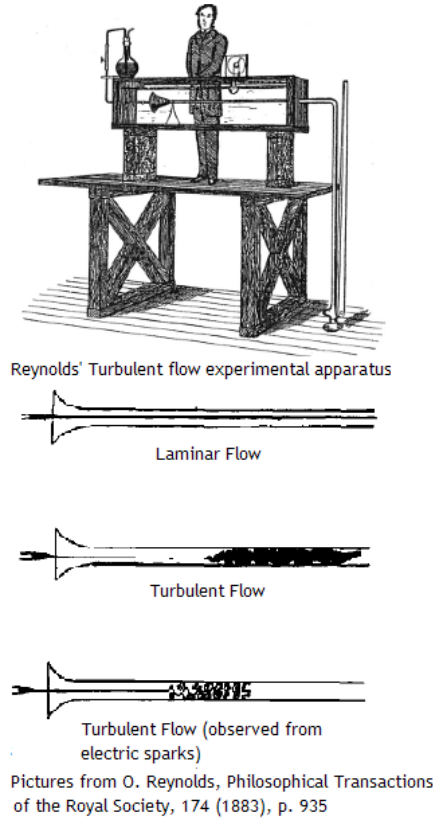

**Figure 5.1.** Osborne Reynolds demonstrating the transition between laminar and turbulent flow

One can observe fluid flows under different conditions. Some examples are fluid flow in open channels under the influence of gravity, pipe flow under imposed pressure drop, environmental flows such as wind, tornados etc. Just by observing one can get a feeling whether it is a “gentle” or “rough” flow. For instance, honey flowing down a plate is slow and gentle. It has a laminar nature meaning that it flows in layers. However, if you observe white water rafting the stream is “rough”. This mixing flow is usually named “turbulent” in fluid mechanics. Therefore, there are two basic types of flows:

1. Laminar and
2. Turbulent

In a series of experiments carried out at Owens Collage, Manchester (which has become the University of Manchester in 1880), Osborne Reynolds has shown the intermittent occurrence of turbulent flow within a pipe (Figure 5.1 shows the experiment).

Transformation of a fluid from laminar to turbulent flow is an interesting phenomenon. It is essential to know the difference between the two as their implications on applications are wide –especially in engineering context.

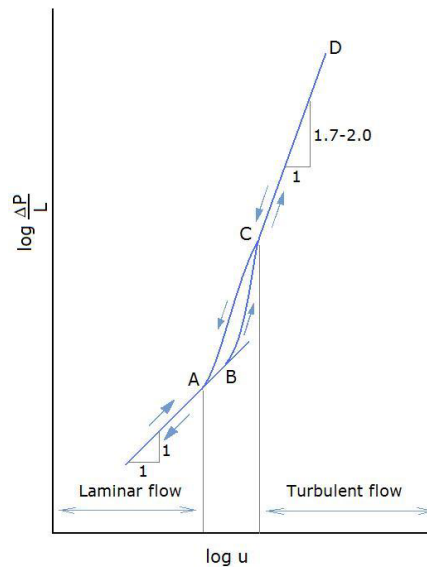

**Figure 5.2.** Pressure drop against the velocity.

Osborn Reynolds carried out a wide range of experiments to characterise this transition in pipe flow. He has plotted the pressure drop against the velocity. This graph is shown in Figure 5.2. A clear change of gradient above certain velocity could be observed. When measurements were made gradually increasing the velocity, at low velocities the curve is linear with a gradient of 1. At point B the curve becomes irregular until point C. From point C onwards, the curve is again becomes linear with a gradient in the range 1.7 to 12.0. This second section represents the turbulent flow regime. The pressure drop is greater than that for the laminar flow in the pipe. This is due to the higher energy dissipation. When the measurements were made starting from a higher flow velocity and decreasing it in small steps, the same curve is followed until point C. Then the data again become scattered and roughly follow a line that connects to the laminar flow section at A. This region where the data point become scattered is the shows the transition between laminar and turbulent flow regimes.

Osborne Reynolds' work on flow in pipes has given a characteristic parameter that defines the flow regime. As seen in Chapter 3, it is a dimensionless number giving the ratio between the inertial forces and the viscous force. This dimensionless number is called the Reynolds number.



$$\text{Reynolds number} = \frac{\rho UL}{\mu}$$

$\rho$ : Density

$\mu$ : Viscosity

$U$ : Velocity

$L$ : Characteristic length

The characteristic length defines flow geometry. For instance, if a liquid flow through a pipe, then pipe diameter is the characteristic length; if it is a flow past a sphere or a pipe, then the diameter of the sphere or the pipe can be taken as the characteristic length.

If the Reynolds number is small, then the flow is said to be laminar and if it is high then the flow is turbulent.

For pipe flow:

$0 < Re < 2300$       *Laminar flow*

$2300 < Re < 5000$       *Transition flow*

$Re > 5000$       *Turbulent flow*

Please click the advert



Discover the truth at [www.deloitte.ca/careers](http://www.deloitte.ca/careers)

**Deloitte.**

© Deloitte & Touche LLP and affiliated entities.

These values arise from experiments provide a rough guide only. The onset of turbulence in flows and characterisation is still a hot topic in fluids research.

In this lecture we explore the properties of laminar and turbulent flows in detail.

## 5.1 Laminar Flow

At low velocities fluid appears to flow in layers with varying velocity. For instance, when a viscous fluid flows down an inclined plane, the velocity increases from 0 at the planar surface to a maximum at the free surface. It appears that the velocity increases in layers and the liquid film does not show any internal mixing. Such flows are known as laminar flows. Laminar flow occur

1. when the liquid viscosity is high (honey flowing on a plate)
2. Liquid velocity is below a certain value
3. When the characteristic length is significantly small (flow in capillaries or in thin films where the diameter or the depth of the film is only few mm).

### 5.1.1 Laminar Flow between two semi infinite planes

Consider a fluid flowing between two inclined parallel plates placed  $h$  distance apart as shown in Figure 5.3. The inclination angle is  $\theta$ . Assume the flow to be steady and laminar. In reality, if the separation between the plates is small then this assumption is true.

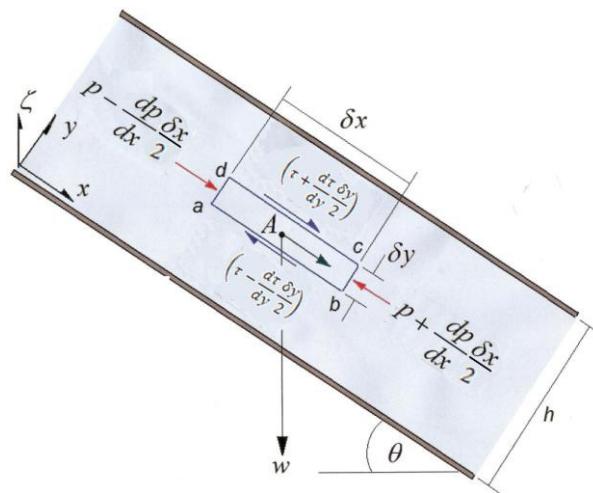

**Figure 5.3.** Laminar flow between two infinitely long plates. Fluid element shows all the forces working on it.

Consider a fluid element in this flow as shown in the figure 5.3. Since the flow is steady, fluid particle does not experience any acceleration. Therefore the resultant force acting on the fluid element has to be zero. This fact can be used to derive the velocity distribution of the fluid.

Assume  $p$  and  $\tau$  to be the pressure and the shear stress at the centre A of the element. The length and the width of the

element are  $\delta x$  and  $\delta y$  respectively. The Cartesian coordinate axis  $x$  and  $y$  are defined along and normal to the bottom plate.

If the pressure at the centre of the element is  $p$  then the pressure at  $ad$  can be written as  $p - \frac{dp}{dx} \frac{\delta x}{2}$  and the pressure at  $bc$  as  $p + \frac{dp}{dx} \frac{\delta x}{2}$ .

Therefore the total force exerted by pressure in  $x$  direction is

$$F_p = \left(p - \frac{dp}{dx} \frac{\delta x}{2}\right) \delta y - \left(p + \frac{dp}{dx} \frac{\delta x}{2}\right) \delta y = -\frac{dp}{dx} \delta x \delta y \quad (a)$$

Similarly the total pressure exerted by the shear stress is

$$F_\tau = \left(\tau + \frac{d\tau}{dy} \frac{\delta y}{2}\right) \delta x - \left(\tau - \frac{d\tau}{dy} \frac{\delta y}{2}\right) \delta x = \frac{d\tau}{dy} \delta x \delta y \quad (b)$$

The weight of the fluid element in the flow direction is

$$F_g = w \sin\theta = \rho g \delta x \delta y \sin\theta \quad (c)$$

Since the flow is steady,

$$F_p + F_\tau + F_g = 0 \quad (d)$$

Substituting (a), (b), and (c) in (d)

$$-\frac{dp}{dx} + \frac{d\tau}{dy} + \rho g \sin\theta = 0 \quad (5.1)$$

If  $\zeta$  is the elevation above some horizontal datum plane, then

$$-\frac{d\zeta}{dx} = \sin\theta \quad (e)$$

By substituting (e) in (1) we can obtain

$$\frac{d\tau}{dy} = \frac{d}{dx} (p + \rho g \zeta) \quad (5.2)$$

From the definition,

$$\tau = \mu \frac{du}{dy} \quad (5.3)$$

Therefore equation (2) can be written as

$$\mu \frac{d^2 u}{dy^2} = \frac{d}{dx} (p + \rho g \zeta) \quad (5.4)$$

This is a second order ordinary differential equation. Functional form of  $u$  can be found by integrating equation (5.4) twice.

Integrating once with respect to  $y$

$$\mu \frac{du}{dy} = \left[ \frac{d}{dx}(p + \rho g \zeta) \right] y + C_1 \quad (5.5)$$

Integrating twice w.r.t  $y$  we get

$$\mu u = \left[ \frac{d}{dx}(p + \rho g \zeta) \right] \frac{y^2}{2} + C_1 y + C_2 \quad (5.6)$$

$C_1$  and  $C_2$  are arbitrary constants arising from the indefinite integration and have to be determined using available information. The fluid that flows is bounded by two *boundaries* namely top and the bottom plates. The conditions that apply at these boundaries define the flow and are very important in fluid mechanics. These are called *boundary conditions*. Later in your course, you will find that fluid flow in flow geometries can be explained by a couple of equations and it is the boundary conditions and the initial conditions that defined the flow.

For this particular case, velocity at both plates is zero as plates remain still at all times. This is called “*no slip*” boundary. At the same time, there is no flow through the plates and therefore no penetration. Therefore, the *boundary conditions* that applies in this case are,

$$u = 0 \text{ at } y = 0 \quad (5.7)$$

and

Please click the advert

## Grant Thornton—<sup>REALLY</sup> a great place to work.

We're proud to have been recognized as one of Canada's Best Workplaces by the Great Place to Work Institute™ for the last four years. In 2011 Grant Thornton LLP was ranked as the fifth Best Workplace in Canada, for companies with more than 1,000 employees. We are also very proud to be recognized as one of Canada's top 25 Best Workplaces for Women and as one of Canada's Top Campus Employers.



**Priyanka Sawant**  
Manager



Audit • Tax • Advisory  
[www.GrantThornton.ca/Careers](http://www.GrantThornton.ca/Careers)



© Grant Thornton LLP. A Canadian Member of Grant Thornton International Ltd

Download free ebooks at [bookboon.com](http://bookboon.com)

$$u = 0 \text{ at } y = h \quad (5.8)$$

Applying the condition given in equation (5.7) on (5.6) one can find

Applying the condition described by equation (5.8) on (5.6)

$$C_1 = - \left[ \frac{d}{dx} (p + \rho g \zeta) \right] \frac{h}{2} \quad (5.9)$$

By substituting values of the constants into equation (5.6) we can derive an equation that represents the velocity profile across the gap between the plates.

$$u = \frac{1}{2\mu} \left[ \frac{d}{dx} (p + \rho g \zeta) \right] (y^2 - hy) \quad (5.10a)$$

Note that Equation (5.10a) gives a negative value for velocity except at  $y=0$  and  $y=h$ . This indicates the sign of the pressure gradient  $\frac{dp}{dx}$ . Fluid flow is in the direction of the negative gradient or towards low pressure. The pressure gradient term remains constant. Therefore the velocity takes a parabolic shape. One can easily find that the maximum velocity occurs at  $h/2$ .

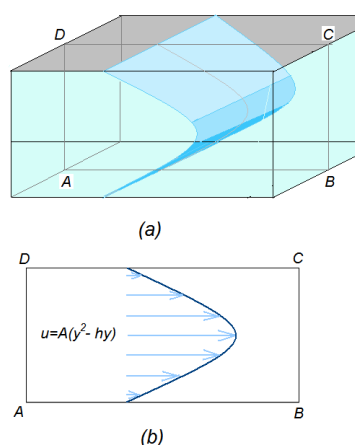

**Figure 5.4.** Velocity profile for laminar flow between two plates

Flow profile between the parallel plates is a parabolic shell as shown in Figure 5.4. There is no velocity gradient in the transverse direction.

If the plates are horizontal, the weight of the fluid is normal to the flow direction ( $\theta = 0$ ). As a result equation (5.10a) reduces to a simpler form indicating that the flow takes place under imposed pressure gradient.

$$u = \frac{1}{2\mu} \left[ \frac{dp}{dx} \right] (y^2 - hy) \quad (5.10b)$$

### 5.1.2 Laminar flow of falling film

If the top plate is removed in the previous case, then it becomes a falling film with a free surface. It is only the ambient air that shears the liquid surface and often considered as stress free when the air is quiescent. This now forms a new boundary condition at  $y=h$ .

$$\text{At } y = h, \quad \tau = 0$$

This leads to  $\frac{du}{dy} = 0$  at  $y = h$  (5.11)

However, the no slip condition holds for the bottom boundary.

$$\text{At } y = 0, \quad u = 0$$
 (5.12)

Flow is down a plane similar to shown in Figure 3 except that there is no plate at the top of the liquid layer.

Boundary conditions have no influence on deriving equation (5.1) and hence equation (5.4). We assumed the flow to be laminar and steady. Therefore, for a steady laminar flow film we can use equation (5.4) as the starting point. There is no pressure gradient as the flow is not confined. The flow takes place due to the gravity acting on the fluid. Therefore,  $\frac{dp}{dx} = 0$ . This reduces the equation one to give

$$\frac{d\tau}{dy} = -\rho g \sin\theta$$
 (5.13)

Substituting  $\tau = \mu \frac{du}{dy}$  in equation (5.13)

$$\mu \frac{d^2u}{dy^2} = -\rho g \sin\theta$$
 (5.14)

Upon integrating twice, we get equation (5.6).

$$\mu u = -\rho g \sin\theta \frac{y^2}{2} + C_1 y + C_2$$
 (5.15)

Applying boundary condition (5.12) on equation (5.15) one can show that

$$C_2 = 0$$
 (5.16)

The upper boundary condition is stress free as long as there are no waves appear at the surface. Applying this condition as defined in the equation (5.11) on (5.6)

$$C_1 = \rho g \sin\theta h$$
 (5.17)

Using the values of  $C_1$  and  $C_2$  in equation (5.15) expression for the velocity distribution becomes

$$u = \frac{\rho g \sin \theta}{\mu} \left( hy - \frac{y^2}{2} \right) \tag{5.18}$$

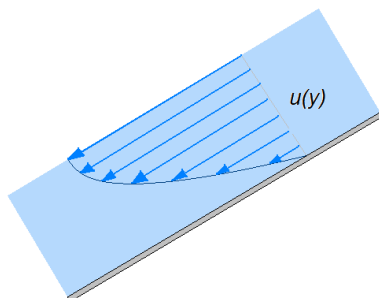

Figure 5.5. Falling film

Equation (18) describes the velocity profile along the depth of the film. The maximum velocity occurs at the surface ( $y = h$ ). Unlike for the flow between two plates, the velocity is positive for all  $y$  values. The velocity profile is half parabolic with maximum velocity at the free surface.

## 5.2 Turbulent flows

Most flows occurring in nature and in industrial applications are said to be turbulent. Unlike in laminar flow, where velocity at a given point remains a smooth function of time, velocity at a point in a turbulent flow shows random fluctuations. Figure 5.6 shows the velocity against time curves for these two situations.

# The Wake

the only emission we want to leave behind

[Low-speed Engines](#) [Medium-speed Engines](#) [Turbochargers](#) [Propellers](#) [Propulsion Packages](#) [PrimeServ](#)

The design of eco-friendly marine power and propulsion solutions is crucial for MAN Diesel & Turbo. Power competencies are offered with the world's largest engine programme – having outputs spanning from 450 to 87,220 kW per engine. Get up front! Find out more at [www.mandieselturbo.com](http://www.mandieselturbo.com)

**Engineering the Future – since 1758.**  
**MAN Diesel & Turbo**



Please click the advert

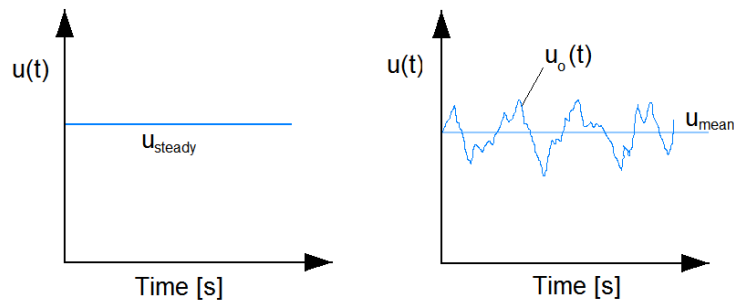

**Figure 5.6.** Velocity against time curves for steady and turbulent flows.

It should be noted that even though the velocity fluctuates in turbulent flows, the mean velocity remains constant. Even though the mean velocity remains constant a slight change to the system will produce a large change to the subsequent motion of the fluid.

As described in the introduction, the parameter used in fluid mechanics to classify flow regimes is the Reynolds number ( $Re$ ).

$$\text{Reynolds number} = \frac{\rho UL}{\mu} = \frac{\text{inertial force}}{\text{viscous force}}$$

The Reynolds number can be written as  $Re = \frac{UL}{\nu}$  where  $\nu = \frac{\mu}{\rho}$  is the kinematic viscosity. Onset of turbulence in pipes could be observed around  $Re = 2300$ . We can simply expect a fluid to be turbulent when  $\nu$  is very small.

It is difficult to provide a formal definition for turbulence. Statistical analysis of velocity fluctuations provide information about the structures that evolve within a turbulent flow. These small structures are called “eddies”. They behave like localised sub-flow within a larger flow that has a definite flow direction. Velocity within eddies may not have the same flow direction as that of the bulk flow. Eddies are formed due to the instabilities in the mean flow. These instabilities could be small mechanical vibrations, irregularities in the boundaries etc. Larger eddies rapidly break into smaller eddies due to inertial instabilities within them. The small eddies breaks down to even smaller vortices. It is important to note that the viscosity plays no part in this breaking down in size. It happens due to the inertial instabilities at each length scale (size of the eddy).

The eddy breakdown is a rapid process. The energy in the large eddies passes down to the next generation without much loss.

This means that the Reynolds number for the eddy calculated using the length scale of that eddy is still large. In an evolving turbulent flow a wide spectrum of eddy sizes could be observed. In other words, there exists an energy cascading within the flow. Highest energy density would be in the smallest eddies. This cascading stop when the  $Re$  calculated using the eddy size reaches a small number letting the viscosity to dissipate the energy in the molecular process.

Turbulence in fluid flows can be thought of as velocity fluctuations ( $u'$ ) around a mean velocity. Therefore the velocity can be written as



$$u = \bar{u} + u' \tag{5.19}$$

The mean kinetic energy  $E$  of the flow described by the equation (19) is given by

$$\begin{aligned} E &= \frac{1}{2} \rho \overline{u^2} = \frac{1}{2} \rho \overline{(\bar{u} + u')^2} \\ &= \frac{1}{2} \rho [\overline{(\bar{u})^2} + 2\overline{\bar{u}u'} + \overline{(u')^2}] \end{aligned} \tag{5.20}$$

The overbar is used to indicate the mean values of the variables. Consider the first term of the equation (5.20). Mean of the square of mean velocity is as same as the square of the mean value. Furthermore, the mean value of the velocity fluctuation is zero as the values can be both positive and negative. Therefore,

$$\begin{aligned} \overline{(\bar{u})^2} &= (\bar{u})^2 \\ \overline{u'} &= 0 \end{aligned}$$

Therefore, the mean kinetic energy of the turbulent flow is given by

$$E = \frac{1}{2} \rho [(\bar{u})^2 + \overline{(u')^2}] \tag{5.21}$$

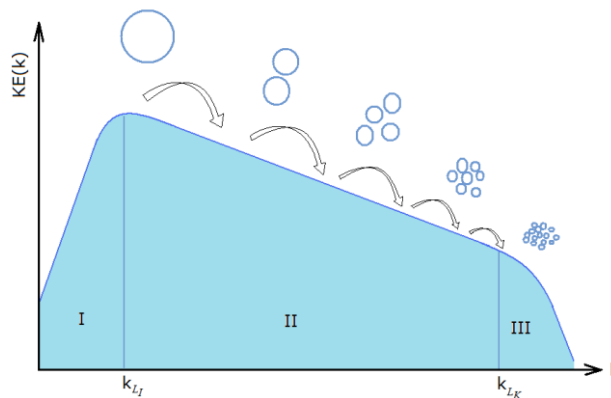

Figure 5.7. Kinetic energy against the wave number. Axes are in log scale

The mean of the  $(u')^2$  does not vanish as squaring generates all positive number series to average. From above derivation it is evident that  $\overline{u^2} = (\bar{u})^2 + \overline{(u')^2}$ .

Equation (5.21) shows that the kinetic energy of a turbulent flow consist of two parts: the kinetic energy of the mean velocity  $(\frac{1}{2} \rho (\bar{u})^2)$  and the kinetic energy of the turbulence  $(\frac{1}{2} \rho \overline{(u')^2})$ . The kinetic energy due to the turbulence,  $\frac{1}{2} \rho \overline{(u')^2}$ , is made of large variation of velocity fluctuations. The velocity fluctuations are due to the eddies in the flow field. These eddies are of different sizes. The large eddies contain higher energies and are unstable. Hence they breakdown into smaller eddies as mentioned at the beginning of this section. The kinetic energy corresponding to different length scales (roughly

the size of the eddies) can be estimated using Fourier analysis. The kinetic energy spectrum can be plotted against the length scale as shown in Figure 5.7. It is customary to plot the kinetic energy against the wave number,  $k$ . Wave number is defined as  $k = \frac{\pi}{l}$  where  $l$  is the length scale of the eddy. Larger eddies have a small wave number while smaller eddies have larger wave number according to this definition.

The energy cascade showed in figure 5.7 shows three regions.

I Energy containing range

II Inertial subrange

III dissipation range

The region I represents the largest eddies where turbulence is generated. The rate at which the energy enters the cascade is usually given by

$$\epsilon_I = \frac{d(KE)}{dt} \sim \frac{du'^2}{dt} \sim \frac{u_0'^2}{L/u'} \sim \frac{u_0'^3}{L}$$

Therefore, the energy enters at a rate of  $\epsilon_I = \frac{u_0'^3}{L}$ . The turn over time of large eddies is given by  $L/u'$ .  $L$  is the inertial length scale. is the velocity associated with the large eddies. The effects of the viscosity are insignificant in this region.

Please click the advert

**I WANT TO CHANGE DIRECTION,  
AND THE WORLD.**

[GOT-THE-ENERGY-TO-LEAD.COM](http://GOT-THE-ENERGY-TO-LEAD.COM)

We believe that energy suppliers should be renewable, too. We are therefore looking for enthusiastic new colleagues with plenty of ideas who want to join RWE in changing the world. Visit us online to find out what we are offering and how we are working together to ensure the energy of the future.

**RWE**  
The energy to lead

The second region (marked II) represent the range of length scales larger eddies breaking down due to nonlinear interactions. This breaking down is not affected by the viscosity. As a result, the energy of the larger eddies is passed down the cascade to smaller eddies. If the energy in this region is denoted by  $\varepsilon_{II}$  then,

$$\varepsilon_I = \varepsilon_{II}$$

The spectrum in the inertial subrange is given by the *Kolmogorov spectrum law* and is given by

$$E(k) = K_0 \varepsilon^{2/3} k^{-5/3}$$

$K_0$  is the Kolmogorov constant. The typical values lie in the range of  $1.4 \leq K_0 \leq 1.7$

The third region contains the smallest length scales (eddies) that feels the influence of the viscosity. As a result the kinetic energy is dissipated into heat. The energy dissipation is given by  $\frac{\nu u_k^2}{L_k^2}$ . The total amount of the energy fed into the flow to generate the turbulence in region I has to be dissipated in the region III. This suggests

$$\frac{u_0'^3}{L} \approx \frac{\nu u_k'^2}{L_k^2}$$

The momentum transfer under turbulent flow has similar implications due to the velocity fluctuations. Consider a small fluid element of volume  $\delta x \delta y \delta z$  as shown in Figure 5.8. In this section for clarity the directions of the velocity vectors are shown as subscripts. For example velocity in x direction is  $u_x$ . Consider the surface perpendicular to x axis. The area is  $\delta y \delta z$ . Mass flowrate across this surface can be calculated by multiplying the area by the velocity in x direction and the density. The momentum in x direction is given by the product of mass with the velocity component in x direction. Let the momentum transport in x direction  $M_{xx}$ .

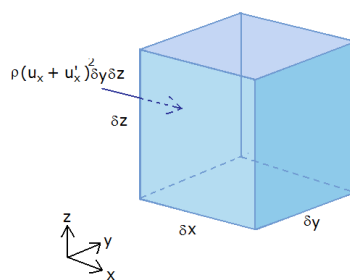

**Figure 5.8.** Momentum of a fluid element

$$\begin{aligned} M_{xx} &= \text{mass flow rate} \times \text{velocity} \\ &= (\rho u_x \delta y \delta z) u_x \\ &= \rho u_x^2 \delta y \delta z \end{aligned}$$

The mean momentum transport across a unit surface area, or the mean momentum flux is then can be written as

$$\bar{M}_{xx} = \rho(\overline{u_x^2} + \overline{u_x'^2}) \quad (5.22)$$

Consider the mass flowrate normal to the face perpendicular to  $y$  axis. There is a component of momentum in  $x$  direction associated with the mass flux due to  $v$  velocity in  $y$  direction. Let the momentum in  $x$  direction on the surface normal to  $y$  axis be  $M_{xy}$ ,

$$\begin{aligned} M_{xy} &= (\rho u_y \delta x \delta z) u_x \\ &= \rho \delta x \delta z u_y u_x \\ &= \rho \delta x \delta z (\overline{u_y} + u_y') (\overline{u_x} + u_x') \\ &= \rho \delta x \delta z (\overline{u_y} \overline{u_x} + \overline{u_y} u_x' + \overline{u_x} u_y' + u_y' u_x') \end{aligned}$$

The mean  $x$  momentum flux on the surface normal to  $y$  axis is

$$\overline{M_{yx}} = \rho(\overline{u_x} \overline{u_y} + \overline{u_x' u_y'}) \quad (5.23)$$

The mean values of the fluctuations vanish but the product  $u_y' u_x'$  would not as they are correlated.

Similarly, the mean  $x$  momentum flux on the surface normal to  $z$  axis could be written as

$$\overline{M_{zx}} = \rho(\overline{u_x} \overline{u_z} + \overline{u_x' u_z'}) \quad (5.24)$$

Consider equation (5.22). The first term on r.h.s,  $\rho(\overline{u_x^2})$ , even though a momentum flux in reality, it appears to act like a normal stress on the surface normal to the  $x$  axis. It can be considered as the apparent normal stress due to the mean velocity gradient. The second term  $\rho(\overline{u_x'^2})$  shows an apparent normal stress due to the velocity fluctuations. Equations (5.23) and (5.24) give the shear stresses on the surfaces normal to  $y$  and  $z$  axes. These apparent stresses due to the velocity fluctuations are called *Reynolds stresses*.

In turbulence modelling, the mean flow equation describes the motion of fluid in terms of mean velocity. This equation shows that the mean field cannot be determined without knowing the Reynolds stresses. This is a closure problem as an extra expression is needed to describe the Reynolds stresses. The crudest method to overcome this problem is to augment the viscosity term to reflect its physical behaviour. To this end the Reynolds stresses is expressed in terms of the mean field.

$$\overline{u_x' u_y'} = \overline{u_x' u_x'} - \nu_T \left( \frac{\partial \overline{u_x}}{\partial y} + \frac{\partial \overline{u_y}}{\partial x} \right) \quad (5.25)$$

More generally

$$\overline{u_i' u_j'} = \overline{u_i' u_i'} - \nu_T \left( \frac{\partial \overline{u_i}}{\partial x_j} + \frac{\partial \overline{u_j}}{\partial x_i} \right) \quad (5.26)$$

The coefficient  $\nu_T$  which is similar to kinematic viscosity is called the *turbulent eddy viscosity*.

Without delving into the complex mathematics associated with turbulence flow analysis, we would address the turbulence in pipe flow. It is essential you understand the impact of turbulence on fluid flows in pipes as chemical engineers are expected to design piping systems to connect process equipment.

Those who are interested in learning more on turbulence are referred to references 4-6 which were used in developing the section presented here.

## References

1. Bird, R.B, Stewart, W.E and Lightfoot, E.N., Transport Phenomena, 2<sup>nd</sup> Ed, Wiley & Sons, 2002.
2. Douglas, J.F., Gasiorek, J.M., and Swaffield, J.A., Fluid Mechanics, 4<sup>th</sup> Ed, Prntice Hall, 2001
3. Holland, F.A. and Bragg, R., Fluid Flow for Chemical Engineers, 2<sup>nd</sup> Ed, Edward Arnold, 1995.
4. Mathieu, J. and Scott, J., An Introduction to Turbulent flow, Cambridge University Press, 2000.
5. Sagaut, P, Deck, S. and Terracol, M., Multiscale and Multiresolution Approaches in Turbulence, Imperial Collage Press, 2006.
6. Davidson, P.A., Turbulence: An introduction for scientists and engineers, Oxford University Press, 2004.

Please click the advert



You're full of *energy*  
and *ideas*. And that's  
just what we are looking for.

Looking for a career where your ideas could really make a difference? UBS's Graduate Programme and internships are a chance for you to experience for yourself what it's like to be part of a global team that rewards your input and believes in succeeding together.

Wherever you are in your academic career, make your future a part of ours by visiting [www.ubs.com/graduates](http://www.ubs.com/graduates).

[www.ubs.com/graduates](http://www.ubs.com/graduates)



© UBS 2010. All rights reserved.

# 6 Viscous Flow in Pipes

## Introduction

In most chemical plants, one or more fluids are transported between vessels such as storage, reactors and separation columns. This is done by pumping the fluids through pipes. The flows in most of the cases are turbulent. However, there are many occasions where laminar flow occurs. For instance in food industry, thicker fluids like chocolate are pumped through pipes at relatively low velocities.

In this section, laminar and turbulent flow in side circular pipes are discussed in detail.

### 6.1 Laminar flow in a circular pipe

As mentioned in the introduction, pipe flow is very common. However, it is difficult to have laminar flow in pipes unless flow velocity is very small (or the fluid has rather large viscosity). If the pipe internal diameter is small, then laminar flow is possible. In fact, flow in capillaries is laminar for a wide range of pressure drops.

An analysis similar to that of section 4.2 can be carried out for steady laminar flow in circular pipe. Consider a pipe with internal diameter  $R$  in which a fluid flow at a constant flow rate giving a velocity  $u$ .

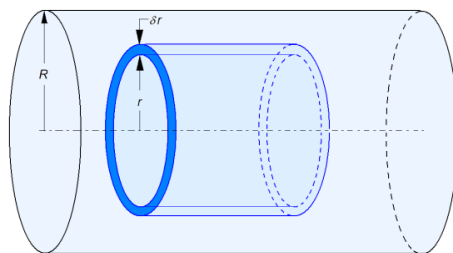

**Figure 6.1.** An annular fluid element in a pipe

Consider an annular fluid element in a pipe. Assume this annular shell has an internal radius  $r$  and a radial thickness  $\delta r$  as shown in the Figure 6.1.

As the fluid element flow down the pipe, the inner wall and the outer wall experience different shear stresses. Assume the static pressure to be  $p$  and the shear stress to be  $\tau$ . The forces acting on the annular fluid element are shown in figure 6.2.

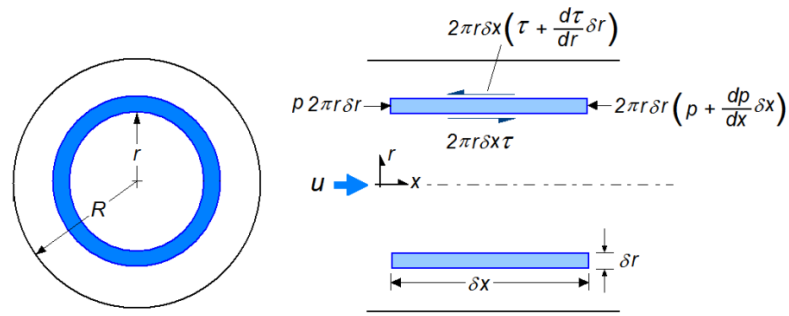

Figure 6.2. Forces acting on the annular fluid element

As the flow is steady the acceleration of the element as it flows down the pipe. Therefore, the net force it experience should be zero. Considering the force exerted on the  $\delta r$  thick ring,

$$F_p = \left[ p - \left( p + \frac{dp}{dx} \delta x \right) \right] 2\pi r \delta r = -2\pi r \delta r \delta x \frac{dp}{dx} \quad (6.1)$$

Now consider the shear stress. With the increase of the radius, the shear stress increases. This has to be taken into consideration when the force balance is carried out on the annular shell.

$$F_t = 2\pi r \delta x \tau - \left( 2\pi r \delta x \tau + \frac{d(2\pi r \delta x \tau)}{dr} \delta r \right) = -2\pi \delta x \delta r \frac{d(r\tau)}{dr} \quad (6.2)$$

Since the flow is steady, there is no net force acting on the fluid element. Therefore,

$$F_p + F_t = 0 \quad (6.3)$$

Substituting for  $F_p$  and  $F_t$  from equations (6.1) and (6.2) in equation (6.3) gives an equation that describes the variation of the stress in radial direction.

$$\frac{d(r\tau)}{dr} = -r \frac{dp}{dx} \quad (6.4)$$

Integrating this equation gives

$$r\tau = -\frac{r^2}{2} \frac{dp}{dx} + C_1 \quad (6.5)$$

At this stage, it can be seen that  $C_1 = 0$  along the centre line of the pipe where  $r = 0$ .

Using the definition of the shear stress, a second order differential equation for the velocity can be derived. At this point we have to consider the direction of the measurement. The velocity increases in the opposite direction to the distance measurement. As a result the shear stress is proportional to the negative of the velocity gradient.

$$\tau = -\mu \frac{du}{dr} \quad (6.6)$$

Substituting equation (6.6) in equation (6.5)

$$\frac{du}{dr} = \frac{r}{2\mu} \frac{dp}{dx} \quad (6.7)$$

Integrating the equation once again with respect to  $r$ ,

$$u = \frac{r^2}{4\mu} \frac{dp}{dx} + C_2 \quad (6.8)$$

Considering the boundary condition that

$$u = 0 \text{ at } r = R \quad (6.9)$$

The constant  $C_2$  can be determined. Applying the condition (6.9) in (6.8),

$$C_2 = -\frac{R^2}{4\mu} \frac{dp}{dx} \quad (6.10)$$

Therefore, the final form of the equation (6.8) that describes the radial velocity profile becomes

$$u = -\frac{(R^2 - r^2)}{4\mu} \frac{dp}{dx} \quad (6.11)$$

Again, the negative sign indicates that the pressure gradient is negative. Equation (6.11) shows that the velocity profile is

Please click the advert



## CAREER KICKSTART

An app to keep you in the know

Whether you're a graduate, school leaver or student, it's a difficult time to start your career. So here at RBS, we're providing a helping hand with our new Facebook app. Bringing together the most relevant and useful careers information, we've created a one-stop shop designed to help you get on the career ladder – whatever your level of education, degree subject or work experience.

And it's not just finance-focused either. That's because it's not about us. It's about you. So download the app and you'll get everything you need to know to kickstart your career.

So what are you waiting for?

Click [here](#) to get started.



parabolic. The maximum velocity occur at the centre of the pipe (according to the equation (6.7), the first derivative of  $u$  w.r.t.  $r$  vanishes only at  $r = 0$ ). Maximum velocity can be derived by setting  $r = 0$  in the equation (6.11).

$$u_{max} = -\frac{R^2}{4\mu} \frac{dp}{dx} \quad (6.12)$$

Radial velocity given by equation (6.11) could be written using the maximum velocity within the pipe.

$$\frac{u}{u_{max}} = \left(1 - \frac{r^2}{R^2}\right) \quad (6.13)$$

Knowing the velocity profile at the steady state in a pipe, the flow rate can be calculated easily.

Consider an annulus with an inner diameter  $r$  and a  $\delta r$  thickness inside the pipe as before. The flow through this annular area is  $\delta Q$ .

$$\delta Q = 2\pi r \delta r \cdot u \quad (6.14)$$

Integrating above equation between 0 and  $R$  the total flow rate can be calculated.

$$Q = \int_0^R 2\pi r u dr = -2\pi \int_0^R \frac{(R^2 - r^2)}{4\mu} \frac{dp}{dx} r dr \quad (6.15)$$

$$Q = -\frac{\pi}{2\mu} \frac{dp}{dx} \int_0^R (R^2 - r^2) r dr$$

$$Q = -\frac{\pi}{2\mu} \frac{dp}{dx} \left[ \frac{R r^2}{2} - \frac{r^4}{4} \right]_0^R$$

$$Q = -\frac{\pi R^4}{8\mu} \frac{dp}{dx} \quad (6.16)$$

The mean flow velocity through the pipe is given by the flowrate divide by the cross sectional area,  $Q/A$ , Therefore,

$$\bar{u} = \frac{Q}{A} = \frac{R^2}{8\mu} \frac{dp}{dx} = \frac{1}{2} u_{max} \quad (6.17)$$

This allows expressing the velocity distribution in terms of the mean velocity.

$$\frac{u}{\bar{u}} = 2 \left(1 - \frac{r^2}{R^2}\right) \quad (6.18)$$

If the inner diameter of the pipe is  $D (=2R)$  and the length is  $L$  with the pressure drop along the length of the pipe is  $\Delta P$  then equation (6.16) can be written as

$$Q = \frac{\pi D^4 \Delta P}{128\mu L} \quad (6.19)$$

By rearranging equation (19) an equation for the pressure drop can be obtained.

$$\Delta P = \frac{128\mu L Q}{\pi D^4} \quad (6.20)$$

Above equation is the well-known *Hagen-Poiseuille* equation. It provides an alternative method to determine the viscosity of a liquid.

## 6.2 Turbulent flow in a pipe

We discussed in laminar flow that the velocity profile within a pipe takes a parabolic shape. This is due to the effects of the viscosity. For turbulent flows the influence of the viscosity is less. Presence of eddies change the local flow continuously. Flow has low velocities only near the walls. Elsewhere the flow is well mixed. As a result, velocity deviates from the parabolic shape. Despite the large volume of research, theoretical and experimental, there is no general accurate expression for the velocity profile. However, an empirical power law velocity profile is often used.

$$\text{For } 0 \leq r \leq R \quad \frac{u}{u_c} = \left(1 - \frac{r}{R}\right)^{\frac{1}{n}} \quad (6.21a)$$

In above equation  $R$  is the radius of the pipe and  $u_c$  is the velocity at the centre line (which is expected to be the maximum velocity). The value of  $n$  is a function of the Reynolds number. The typical values used are between  $n = 6$  and  $n = 10$ . In most cases  $n = 7$  is preferred. This number is suggested by a well known German physicist Ludwig Prandtl. Resulting equation is called the *Prandtl's 1/7 power law* (Equation (6.21b)).

$$\frac{u}{u_c} = \left(1 - \frac{r}{R}\right)^{\frac{1}{7}} \quad (6.21b)$$

Since an analytical equation that approximate the velocity profile within a pipe for turbulent flow is available, the mean flowrate can be calculated. The approach is similar to the one used in laminar flow in a pipe.

Consider an annular disk with radius  $r$  and width  $dr$ . Assume the flow across this disk to be  $dQ$ .

$$dQ = 2\pi r dr \cdot u \quad (6.22)$$

Substituting equation (6.21) in (6.22) and integrating between  $r=0$  and  $r=R$

$$Q = 2\pi u_c \int_0^R r \left(1 - \frac{r}{R}\right)^{\frac{1}{7}} dr \quad (6.23)$$

Integration w.r.t.  $r$  gives the flowrate inside the pipe.

$$Q = \frac{49}{60} \pi R^2 u_c \quad (6.24)$$

Carry out the integration to check equation (6.24). Hint: use the method of substitution

Considering the fact that the mean flow is given by  $Q/A$ ,

$$\bar{u} = \frac{49}{60}u_c = 0.82u_c \tag{6.25}$$

Equation (6.21) can be written in terms of mean flow.

$$\frac{u}{\bar{u}} = \frac{60}{49} \left(1 - \frac{r}{R}\right)^{\frac{1}{7}} = 1.22 \left(1 - \frac{r}{R}\right)^{\frac{1}{7}} \tag{6.26}$$

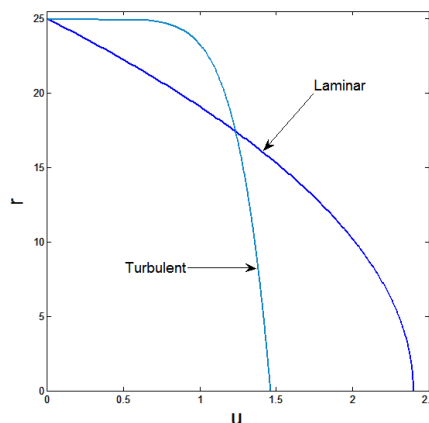

Figure 6.3 Laminar and turbulent velocity profiles

Velocity profile given by equation (6.26) is shown in Figure 6.3 below together with the laminar flow profile for comparison. The profiles are calculated for a flow with a mean velocity of 1.5 m/s in a 50mm diameter pipe.

Please click the advert

**ORACLE®**

**Be BRAVE**  
**enough to reach for the sky**

Oracle's business is information - how to manage it, use it, share it, protect it. Oracle is the name behind most of today's most innovative and successful organisations.

Oracle continuously offers international opportunities to top-level graduates, mainly in our Sales, Consulting and Support teams.

If you want to join a company that will invest in your future, Oracle is the company for you to drive your career!

<https://campus.oracle.com>



**ORACLE®**

**ORACLE IS THE INFORMATION COMPANY**

In turbulent flow, the velocity reaches a higher value nearer to the wall. Then the velocity follows a “nearly flat” profile towards the centre line reaching a maximum at the centre. In laminar flow the velocity increases gradually towards the centre line.

### 6.3 Bernoulli Equation revisited

In a previous lecture, we have derived the Bernoulli equation.

$$\frac{P_1}{\rho g} + \frac{v_1^2}{2g} + z_1 = \frac{P_2}{\rho g} + \frac{v_2^2}{2g} + z_2 = E \quad (6.27)$$

This equation describes conservation of the mechanical energy in a fluid flow. The major assumption during the derivation is that the fluid is inviscid. In the case of ideal fluid flow in a pipe there will be no velocity gradient across a pipe cross section. However, for viscous fluids (real fluids) depending on the flow regime, velocity varies differently as shown in Figure 6.4.

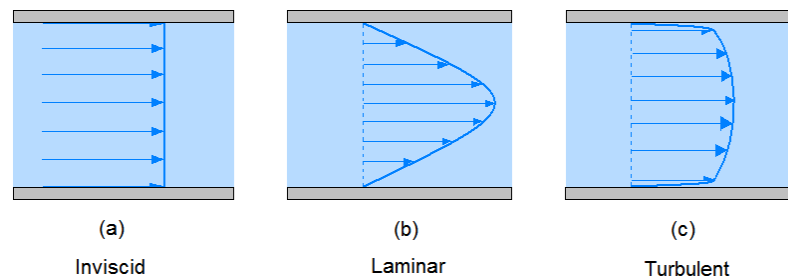

Figure 6.4. Influence of the viscosity on the velocity profiles

For inviscid fluids, the mean flow velocity is exactly as same as the velocity at any point on the cross section considered. Therefore, in calculating the kinetic energy at any cross section, using the mean flow is as same as using the actual velocity. However, this is not true for viscous fluids. Real flows develop velocity gradients. As a result the kinetic energy computed at a cross section using the mean flow is not accurate. To correct this discrepancy, a correction has to be made. In following two sections we estimate the correction factor for the laminar and turbulent flows in a pipe.

#### 6.3.1 Kinetic energy correction factor -Laminar flow in a pipe

Consider a laminar pipe flow. Assume the volumetric flowrate to be  $Q$  and the radius of the pipe to be  $R$ . The mean flow is given by

$$\bar{u} = \frac{Q}{A} \quad (6.28)$$

Using the mean flow calculate the kinetic energy.

$$KE_{\bar{u}} = \text{mass flowrate} \times \frac{\bar{u}^2}{2} \quad (6.29)$$

$$KE_{\bar{u}} = \pi R^2 \rho u \times \frac{\bar{u}^2}{2} = \frac{1}{2} \pi \rho R^2 \bar{u}^3 \quad (6.30)$$

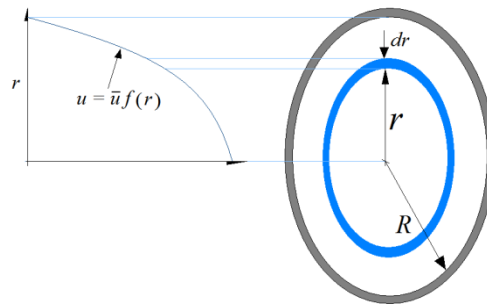

Figure 6.5 velocity profile in a circular pipe

We can calculate the kinetic energy for the same flow taking the dependency of the velocity on the radial position into account. This would give a more accurate estimation of the kinetic energy. The velocity profile is given in the equation (6.18). Consider an annulus with a radius  $r$  as shown in Figure 6.5.

Kinetic energy of the fluid passing the annulus is  $d(KE_u)$

$$d(KE_u) = 2\pi r dr \cdot \rho u \cdot \frac{u^2}{2} \quad (6.31)$$

Using the laminar velocity profile as in equation (6.18) the kinetic energy can be estimated.

$$KE_u = 8\rho\pi\bar{u}^3 \int_0^R r \left(1 - \frac{r^2}{R^2}\right)^3 dr \quad (6.32)$$

$$KE_u = \rho\pi\bar{u}^3 R^2 \quad (6.33)$$

Comparing equations (6.29) and (6.32) shows that

$$KE_u = 2KE_{\bar{u}} \quad (6.34)$$

Actual kinetic energy calculated using the laminar flow velocity is twice the value of the kinetic energy calculated using the mean flow. Therefore the kinetic energy correction factor in Bernoulli equation is 2.

### 6.3.2 Kinetic energy correction factor -Turbulent flow in a pipe

You might have realised that the equation (6.29) applies to turbulent flow in a pipe too as it is based on the mean flow. To calculate the kinetic energy for turbulent flow in a pipe, a procedure similar to the one used in the previous section is used with one exception: analytical function for velocity. Prandtl's 1/7 law is used. We are using it in the form given by equation (6.26).

Considering an annulus with the radius  $r$ , the kinetic energy can be calculated.

$$KE_u = \left(\frac{60}{49}\right)^3 \rho \pi \bar{u}^3 \int_0^R r \left(1 - \frac{r}{R}\right)^7 dr \quad (6.35)$$

$$KE_u = 0.53 \rho \pi \bar{u}^3 R^2 \quad (6.36)$$

Comparing with equation (6.29) shows that

$$KE_u = 1.06 KE_{\bar{u}} \quad (6.37)$$

Therefore the correction factor is 1.06.

### 6.3.3 Bernoulli Equation for viscous pipe flow

It is always easier to measure the mean flowrate. As a result, it is the quantity used in computing the kinetic energy component in the Bernoulli equation. However, as shown in previous two sub sections (6.3.1 and 6.3.2), a correction has to be made to compensate for the variation in the velocity in viscous flows.

Therefore, for viscous flows the Bernoulli equation can be written as

$$\frac{P_1}{\rho g} + \alpha \frac{v_1^2}{2g} + z_1 = \frac{P_2}{\rho g} + \alpha \frac{v_2^2}{2g} + z_2 = E \quad (6.38)$$

For laminar flow  $\alpha = 2$

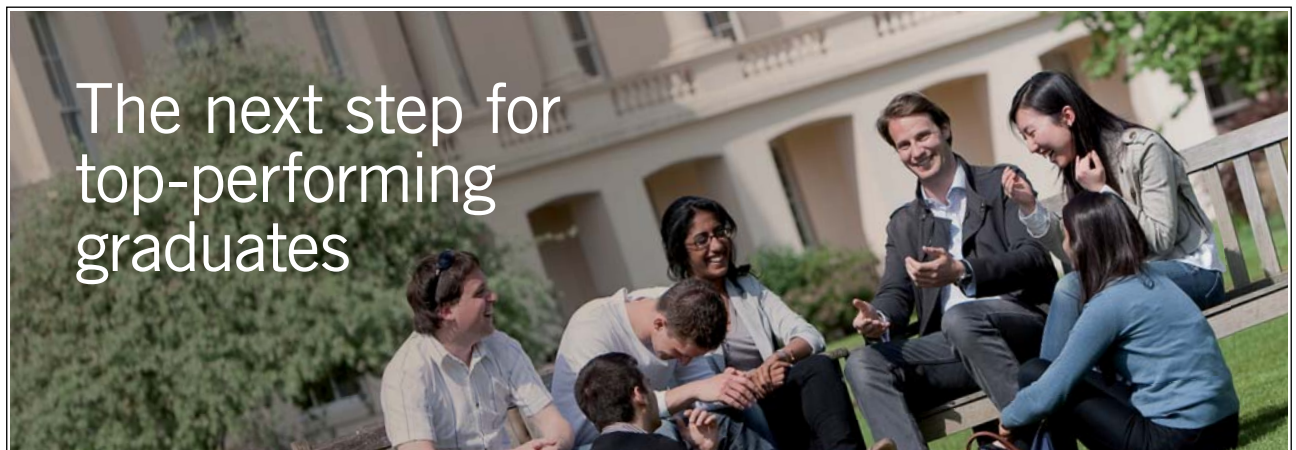

Please click the advert

#### Masters in Management

Designed for high-achieving graduates across all disciplines, London Business School's Masters in Management provides specific and tangible foundations for a successful career in business.

This 12-month, full-time programme is a business qualification with impact. In 2010, our MiM employment rate was 95% within 3 months of graduation\*; the majority of graduates choosing to work in consulting or financial services.

As well as a renowned qualification from a world-class business school, you also gain access to the School's network of more than 34,000 global alumni – a community that offers support and opportunities throughout your career.

For more information visit [www.london.edu/mm](http://www.london.edu/mm), email [mim@london.edu](mailto:mim@london.edu) or give us a call on **+44 (0)20 7000 7573**.

\* Figures taken from London Business School's Masters in Management 2010 employment report



For turbulent flow  $\alpha = 1.06$

Considering the values of the correction factors it can be seen that it is essential to apply it to the laminar flow. However, the correction factor for the turbulent flow in a pipe the correction factor can be neglected as it is almost unity (like that of inviscid flow). This is due to the fact that the viscous effects are dominant only within a narrow layer near the wall. For the rest of the region, velocity varies very little as shown in Figure 6.3.

## 6.4 Losses in pipes

Now that we have introduced the correction factors to the Bernoulli equation, it is applicable to viscous fluid flow in pipes. Therefore,  $\frac{P_1 - P_2}{\rho g} + \alpha \frac{v_1^2 - v_2^2}{2g} + (z_1 - z_2)$  should vanish. In reality, for pipes with bends and valves, this produces a considerable value. Usually the total energy at point 2 (depicted in the equation by subscript 2) is less than that of at point 1 in the pipe. This suggests that some of the energy is lost between the two points. Therefore

$$\frac{P_1 - P_2}{\rho g} + \alpha \frac{v_1^2 - v_2^2}{2g} + (z_1 - z_2) = H_f \quad (6.39)$$

$H_L$  is the amount of head loss within the pipe section L. If the pipe has a constant diameter, then  $v_1 = v_2$ . Furthermore, if the pipe is horizontal, then  $z_1 = z_2$ . Therefore equation (6.38) reduces to

$$\frac{P_1 - P_2}{\rho g} = H_f \quad (6.40)$$

Dimensional homogeneity shows that the dimension of  $H_L$  is that of length [L]. Multiplying both sides by g, we get the energy loss per unit mass with the correct units (J/kg).

$$\frac{P_1 - P_2}{\rho} = h_f \quad (6.41)$$

This suggests that the major contributor to the energy loss in fully developed pipe flow is the pressure loss. The mechanical energy of the flow is converted into thermal energy due to the frictional effects. For a pipe with constant diameter, the head loss is independent of the pipe orientation.

Head loss varies with the flowrate. Therefore, it has to be estimated taking into account the flow velocity. As flows in pipes are either laminar or turbulent, we can use equation (6.41) to derive functional forms for the head loss.

### 6.4.1 Pressure loss in laminar pipe flow

Energy loss in a pipe for a fully developed flow is given by the equation (6.41).

$$P_1 - P_2 = \Delta P = \rho h_f \quad (6.41a)$$

Poiseuille equation (Eq (6.20)) gives the pressure drop as a function of the flow rate. Substituting equation (6.20) in the equation (6.41a)

$$h_f = \frac{128\mu L Q}{\pi\rho D^4} \quad (6.42)$$

$$Q = A\bar{u} = \frac{\pi D^2}{4} \bar{u} \tag{6.43}$$

Substituting equation (6.43) in (6.42)

$$\begin{aligned} h_f &= \frac{128\mu L}{\pi\rho D^4} \frac{\pi D^2 \bar{u}}{4} = 64 \left[ \frac{L}{D} \right] \left[ \frac{\mu \bar{u}}{2\rho D} \right] \\ &= 64 \left[ \frac{L}{D} \right] \left[ \frac{\mu \bar{u}}{2\rho D} \right] \\ h_f &= \left[ \frac{64}{Re} \right] \left[ \frac{L}{D} \right] \left[ \frac{\bar{u}^2}{2} \right] \end{aligned} \tag{6.44}$$

Therefore, from the equation (6.41a),

$$\Delta P = \left[ \frac{64}{Re} \right] \left[ \frac{L}{D} \right] \left[ \frac{\rho \bar{u}^2}{2} \right] \tag{6.45}$$

### 6.4.2 Pressure loss in turbulent pipe flows

For the fully developed turbulent flow in a pipe, the cause of the pressure loss is the fluid friction mainly at the pipe walls. Using a semi-empirical approach, we can derive an equation that relates the pressure drop to other physical and geometrical parameters. Consider a small length of a pipe as shown in Figure 6.6.

Simply balancing the forces acting on the pipe

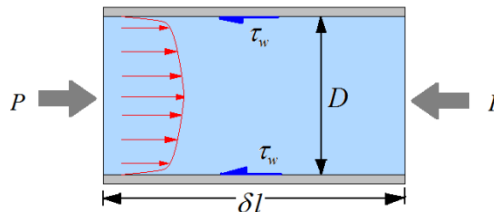

Figure 6.6. Turbulent flow in a pipe

$$\begin{aligned} \left[ P - \left( P + \frac{dP}{dl} \delta l \right) \right] A - D\pi \delta l \tau_w &= 0 \\ -\frac{dP}{dl} A - D\pi \tau_w &= 0 \end{aligned} \tag{6.46}$$

Considering the fact that the pressure gradient is negative

$$\begin{aligned} \frac{dp}{dl} &= \frac{4\tau_w}{D} \\ \frac{\Delta P}{\delta l} &= \frac{8}{D} \left[ \frac{\tau_w}{\rho \bar{u}^2} \right] \left[ \frac{\rho \bar{u}^2}{2} \right] \end{aligned} \tag{6.47}$$



The dimensionless group  $\frac{\tau_w}{\rho \bar{u}^2}$  is known as the friction factor  $\phi$ .

Equation (6.47) can be rearranged as

$$\Delta P = 8\phi \left[ \frac{L}{D} \right] \left[ \frac{\rho \bar{u}^2}{2} \right] \quad (6.48)$$

Equation (6.48) is known as the Darcy's equation. Comparison between equations (6.45) and (6.48) shows that for laminar flow,  $\left[ \frac{64}{Re} \right]$  provides the friction factor equivalent to  $8\phi$ .

Both equations (6.45) and (6.48) give the pressure loss. In order to convert the pressure loss to head loss the equations must be divided by  $\rho g$ . Therefore

The friction factor  $\phi$  depends on the shear stress develop at the wall. Shear stress at the wall depends on the nature of the wall. The shear stress will be higher if the wall is rough. Therefore, we can simply deduce that the friction factor is a function of the wall roughness usually denoted by  $e$ .

Furthermore, the shear stress at the wall depends on the flowrate and the viscosity of the fluid. Since the friction factor is a nondimensional quantity, we can express it as a function of nondimensional roughness and the Reynolds number.

$$\phi = f\left(Re, \frac{e}{D}\right) \quad (6.49)$$

In designing piping systems in the industry, to calculate the head loss due to pipe friction, a chart is used. This is called the Moody diagram (figure 7) or the pipe friction chart. Moody diagram is a plot of friction factor  $\phi$  against the Reynolds number. It contains a family of curves representing various relative roughness values  $\frac{e}{D}$ .

### 6.4.3 Pipe roughness

Microscopic analysis shows that the solid surfaces are not smooth. Instead they have small cavities and other irregularities. The roughness  $e$  is the mean depth of the unevenness of the surface. Pipes made out of different materials, depending on the fabrication techniques, have different surface roughness. Furthermore, as the pipes age this roughness could increase due to corrosion or scaling. Following table (Table 6.1) gives the absolute roughness  $e$  for common piping materials used. Note that the values given are for new surfaces.

Material	$e$ (mm)
Drawn tubing	0.0015
Commercial steel	0.046
Wrought iron	0.046
Cast iron	0.026
Concrete	0.3 - 3.0

**Table 6.1.** Wall roughness for different materials

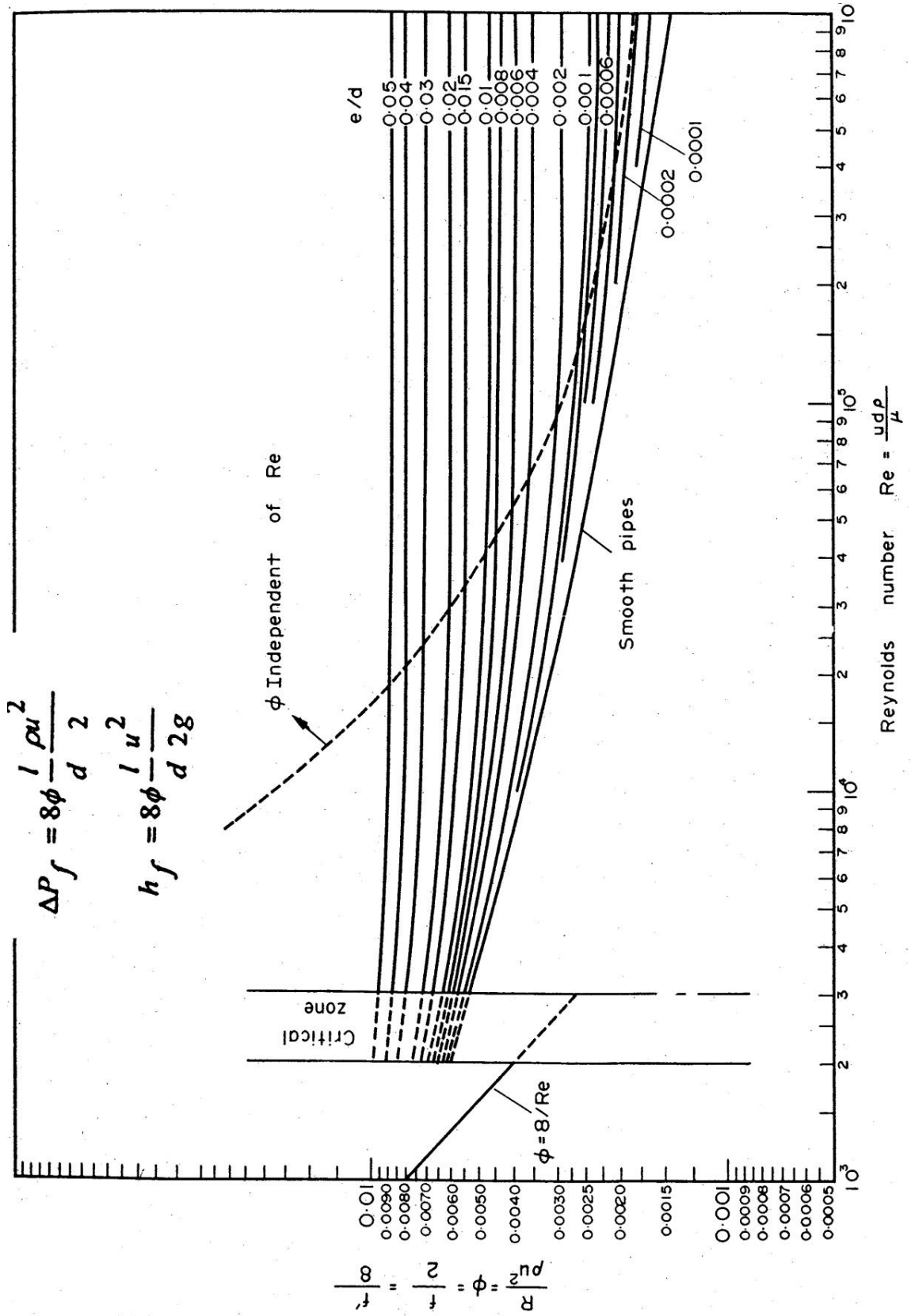

Figure 7. Moody diagram

## 6.5 Other head losses in pipes

We have identified that the major contribution to head loss is the pipe friction. However, other fittings such as bends and valves contribute to the head loss as they induce secondary flow patterns. For long pipe lines these secondary losses can be neglected in comparison to the friction losses. However, it should be noted that the total of these minor losses can easily add up to a considerable head loss. Therefore we usually take these into account in designing piping systems.

The head loss due to fittings is expressed in two different ways. One method is to express the pressure loss in terms of an equivalent pipe length. For instance, suppose a 90° elbow bend in a pipe line induces a head loss  $h$ . This can be expressed as the length of the pipe required to replace the bend (thus straightening the pipe line) keeping the head loss at  $h$ . General practice is to state the length in terms of diameters of the pipe.

The other method is to express the head loss due to fittings in terms of velocity heads  $\left(\frac{\bar{u}^2}{2g}\right)$ . Therefore, the head loss due to fittings can be expressed as  $(L/D)$  or  $K\left(\frac{\bar{u}^2}{2g}\right)$ . Table 6.2 lists head losses due to some frequently used fittings.

Fitting		L/D	K
45° standard elbow		15	0.35
45° long radius elbow		10	0.2
90 standard radius elbow		30 – 40	0.6 – 0.8
90 standard long elbow		23	0.45
90 square elbow		75	1.5
Gate valve	Fully open	0.15	7.5
	¾ open	40	1
	½ open	200	4
	¼ open	800	16

**Table 6.2.** Head losses due to some frequently used fittings

There are two more situations to consider: (a) sudden expansions and (b) sudden contractions as in entry of a pipe to a tank and exit pipe from a tank.

### (a) Sudden expansion

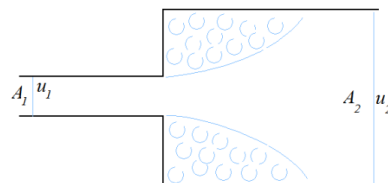

In the case of sudden expansion, Bernoulli equation can be applied to find the head loss  $H$  across the expansion.

$$H = \left[ \frac{\bar{u}_1^2}{2g} \right] \left[ 1 - \frac{A_1}{A_2} \right]^2$$

If the expansion is considerably large,  $\frac{A_1}{A_2} \ll 1$ , giving the head loss to be one velocity head ( $L/D=50$ ) calculated using the mean velocity in the pipe.

(b) Sudden contraction

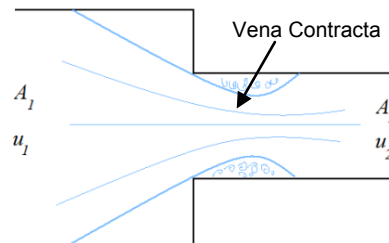

Using a similar approach as for the sudden expansion, an expression for the head loss across a sudden contraction can be derived. However, it should be noted that the formation of the *vena contracta* has to be taken into account in deducing the equation.

$$H = \left[ \frac{\bar{u}_2^2}{2g} \right] \left[ \frac{A_1}{A_c} - 1 \right]^2 = \left[ \frac{\bar{u}_2^2}{2g} \right] \left[ \frac{1}{C_c} - 1 \right]^2$$

If  $A_1 \gg A_2$ , then the head loss becomes half a velocity head computed using the average velocity in the smaller pipe. Therefore, when outlet from a tank is considered, using  $K=0.5$  is acceptable. For different ratios of diameters of the expansion sections,  $K$  takes values between 1 and 0. There is no head loss when the ratio between the diameters is 1. Table 6.3 shows some of the measured values.

$D_2/D_1$	0	0.2	0.4	0.6	0.8	1.0
$(1/C_c - 1)^2$	0.5	0.45	0.38	0.28	0.1	0.0

**Table 6.3** Head loss values for  $D_2/D_1$  ratios

References

1. Bird, R.B., Stewart, W.E., and Lightfoot E.N., Transport Phenomena, 2 Ed., John Wiley & Sons, 2002.
2. Fay J.A., Introduction to Fluid Mechanics, MIT Press, 1994.
3. Fox R.W., McDonald, A.T., Pritchard, P.J., Introduction to Fluid Mechanics, 6th Ed., John Wiley & Sons, 2003.

# 7 Pumping of liquids

## Introduction

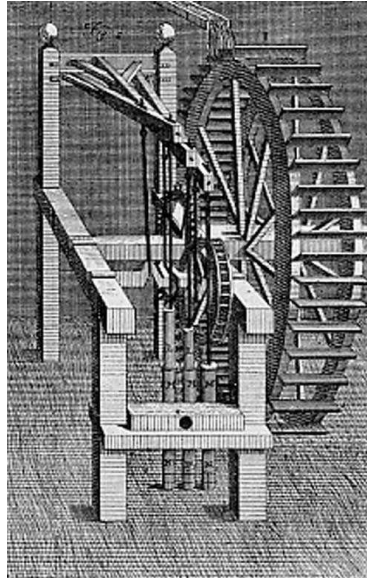

**Figure 7.1.** Sorocold's water pumping machine

Pumping of liquid arguably is the earliest use of machinery in human endeavour to build civilisation. Running water is recorded in few ancient civilisations. Harrappans in Mohenjo Daro civilization which vanished around 1900 BC, had water running in brick walled pipes. Even though the mechanism they used is unknown to us, the water wheel seems to be as ancient as known civilisations. Water wheel is a partially submerged wooden structure with buckets at the brim of the wheel. Buckets collect water as they submerged and poured them into a channel as the wheel rotated due to the force exerted by the stream. The same mechanism provided the early form of the rotary motor. Pumps and motors are the most widely used machines today.

Another form of the water pumping device is the Archimedes's screw. It is a wooden screw placed in a cylindrical shell. As the screw rotates the water rises up the cylinder to a higher level. The next technology jump in pumps came in 1692 when a Derbyshire engineer called George Sorocold built a water pumping machine (Figure 7.1) based on the water wheel to provide running water to Macclesfield (Cheshire, UK). He used bored elm trunks as pipes.

Since these early machines, pumps have evolved to what they are today. There are many different types of pumps are in use depending on the flow properties of the fluid as well as the required pressure. They form an integral part of chemical process plants, water works, and nuclear industry. Pumping requires energy and the wrong selection may leads to higher costs and poor performance. Therefore it is essential to use the correct pump that meets the system requirement.

## 7.1 Pump classification

As mentioned in the previous section, pumps evolved through time. Many inventors developed various types for a range of applications. As a result there are a number of different types of pumps. Pumps move liquid from one point to the other by adding energy to the liquid it pumps. This energy converts into a higher pressure generating a flow. A closer look shows that, even though there are many different types, there are only two forms of energy addition to the fluids: (1) continuously working on the fluid generating higher kinetic energy that converts into pressure (2) increasing pressure by displacing the liquid. Pumps that use the first mechanism are called the dynamic pumps. Positive displacement pumps use the second mechanism to generate the flow. There is a third category that uses special effects such as Venturi suction and hydraulic ram to pump liquids. A broad classification of the pumps is given in Figure 7.2.

Please click the advert

# Destination MMU



Manchester  
Metropolitan  
University

MMU is proud to be one of the most popular universities in the UK. Some 34,000 students from all parts of the globe select from its curricula of over 1,000 courses and qualifications.

We are based in the dynamic yet conveniently compact city of Manchester, located at the heart of a sophisticated transport network including a major international airport on the outskirts. Parts of the campus are acclaimed for their architectural style and date back over 150 years, in direct contrast to our teaching style which is thoroughly modern, innovative and forward-thinking.

MMU offers undergraduate and postgraduate courses in the following subject areas:

- Art, Design & Performance
- Computing, Engineering & Technology
- Business & Management
- Science, Environmental Studies & Geography
- Law, Education & Psychology
- Food, Hospitality, Tourism & Leisure Studies
- Humanities & Social Science



For more details or an application form please contact MMU International.  
email: [international@mmu.ac.uk](mailto:international@mmu.ac.uk)  
telephone: +44 (0)161 247 1022  
[www.mmu.ac.uk/international](http://www.mmu.ac.uk/international)

Download free ebooks at [bookboon.com](http://bookboon.com)

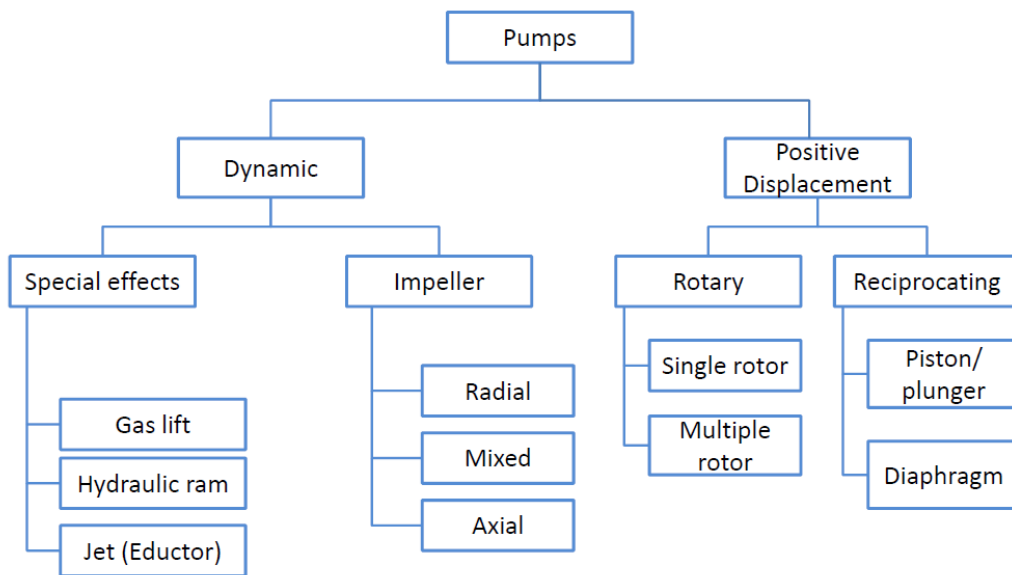

**Figure 7.2.** Classification of pumps

The dynamic pumps mostly have Impellers that rotate around its centre axis at a high frequency. Some pumps have inlet feeding liquid to the centre of the fast rotating impeller. The liquid is forced radially outward due to the centrifugal force. The discharge flow direction is usually normal to the inlet flow direction in these pumps. These are called radial or centrifugal pumps. Figure 7.3(a) shows a typical centrifugal pump. In another type of pumps, the impeller is placed in concentric with the conduit as shown in Figure 7.3(b). A propeller is used as the impeller that induces axial flow when rotating. They are called axial pumps.

The special effects are used in various industrial settings to generate fluid flow. The gas lift is used in the oil industry to lift crude oil from wells with insufficient reservoir pressure. Gas is bubbled into the crude oil using specially designed spargers. The mixture density is lower than the crude oil itself and hence rises up the riser. The venturi eductors work on the venturi effect discussed earlier. A motive fluid is used to generate a low pressure at the throat which is connected to an inlet through which the low pressure stream could be drawn in. They are commonly used with a barometric column to generate low pressure in industrial evaporators.



Figure 7.3. Different types of impeller pumps

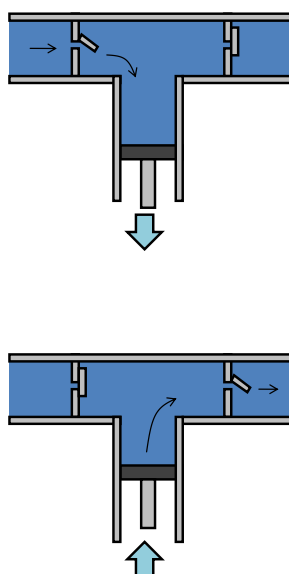

Figure 7.4. The working principle of reciprocating pump

Positive displacement pumps effectively push the liquid creating higher pressure. The periodic operation of a piston (reciprocating pumps) or a diaphragm displaces the liquid continuously. Figure 7.4 shows the concept of the reciprocating pump. Consider a pipe section with a Tee. The two ends on the straight section are fitted with non-return valves and the side third is fitted with a piston. The non-return valves are fitted in a way that flow would occur only in one direction; left to right in this example. When piston withdraws, the non-return valve on the left hand side opens allowing liquid to fill the cavity. The non-return valve on the right remains closed preventing the back flow. On the compression stroke, the left valve closes and the valve on the right will open allowing liquid to flow out under the pressure generated by the piston. Diaphragm pumps works on the same principle but instead of a piston a flexible diaphragm is used.



The rotary pumps are also positive displacement pumps. They use lobes or screws to direct the flow with increasing pressure. Figure 7.5 shows few commonly used rotary and reciprocating pumps.



Lobe pump

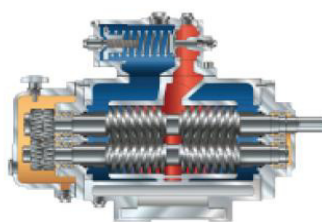

Screw pump

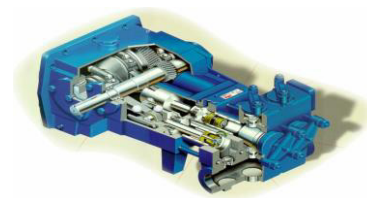

Piston pump

**Figure 7.5.** Positive displacement pumps

## 7.2 Centrifugal pumps

Centrifugal pumps are the most widely used. Therefore the focus of this chapter is to outline how to select the correct centrifugal pump by analysing the piping system requirements. Before moving into the requirements analysis, the head generation mechanism of the centrifugal pump is discussed.



# Get Internationally Connected at the University of Surrey

**MA Intercultural Communication with International Business**  
**MA Communication and International Marketing**

Please click the advert



### **MA Intercultural Communication with International Business**

Provides you with a critical understanding of communication in contemporary socio-cultural contexts by combining linguistic, cultural/media studies and international business and will prepare you for a wide range of careers.

### **MA Communication and International Marketing**

Equips you with a detailed understanding of communication in contemporary international marketing contexts to enable you to address the market needs of the international business environment.

For further information contact:

T: +44 (0)1483 681681

E: [pg-enquiries@surrey.ac.uk](mailto:pg-enquiries@surrey.ac.uk)

[www.surrey.ac.uk/downloads](http://www.surrey.ac.uk/downloads)

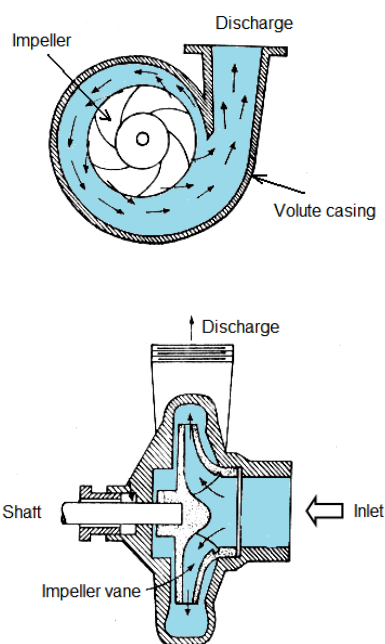

**Figure 7.6.** working principle of the centrifugal pump

Centrifugal pumps basically have a fast rotating impeller encased in a volute casing. The space between the impeller and the casing increases towards the outlet as shown in Figure 7.6(a). Inlet opening of the casing is concentric with the impeller. Impeller is a disc fitted with vanes. The first straight vane impeller centrifugal pump was designed by Denis Pepin (1647 – 1712). This basic design was improved by John Appold in 1851 by introducing the curved vanes. This type of vanes is still in use. The gap between the vanes increases progressively towards the circumference of the impeller disk.

Liquid is introduced at the centre of the fast rotating impeller (eye of the impeller). The centrifugal force acting on the liquid enforces radial flow. The fluid gains velocity increasing the kinetic energy. The curved vanes minimize the energy losses. As the liquid leaves the impeller it follows the channel with gradually increasing flow area between the impeller and the volute casing. As the cross sectional area increases pressure is gained at the expense of the kinetic energy. As a result a higher pressure is realised at the outlet. The pressure it generated is called the pressure head or simply the *head*. The meaning of the term head has been discussed in detail in Chapter 4 section 4.7 under Bernoulli equation.

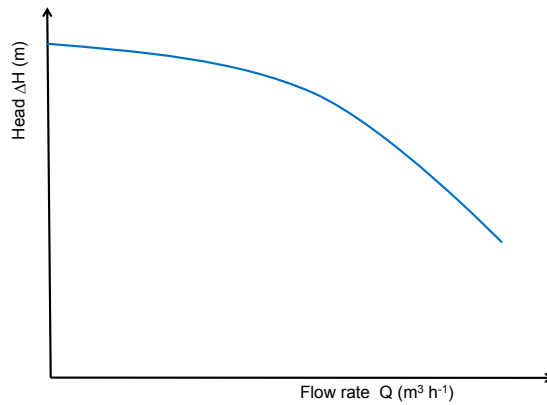

**Figure 7.7.** Pump characteristic curve for a centrifugal pump

There is a direct relationship between the head that a pump can generate and the through put of the pump. The head a pump can generate depends on the impeller diameter and the rotational speed (rpm). For a fixed impeller speed, the total head against the capacity curve is shown in Figure 7.7.

The head at zero flowrate is the shut valve head which is the maximum head a pump can produce. As the flow rate increases the total head decreases along the curve. Pump can operate at any point on this curve. Pump manufacturers usually produce the characteristic curve (Pump curve) using water. It should be noted that the curve become steeper as the viscosity increases.

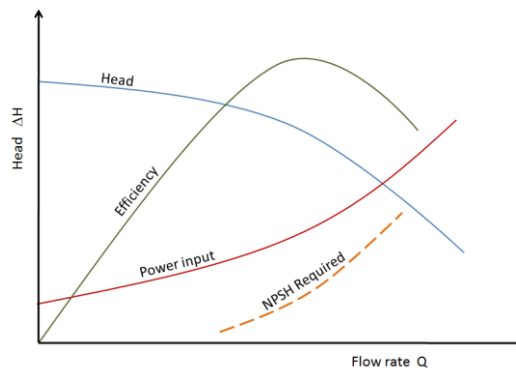

**Figure 7.8.** Typical pump characteristic curves for a centrifugal pump

The total head against the capacity is not enough to characterise the performance of a centrifugal pump. Family of curves are plotted against the capacity to describe the performance of a centrifugal pump. They are the power, required Net Positive Suction Head and the efficiency against the capacity. NPSH will be discussed in detail at a later stage. These characteristic curves are shown in Figure 7.8.

With increasing impeller speed the head increases. This appears as a shift of the curve as a whole. Similar effect can be seen on the power requirement curves. The efficiency curves spread more with increasing impeller speed. Figure 7.9 shows the influence of impeller speed on total head, power and efficiency.

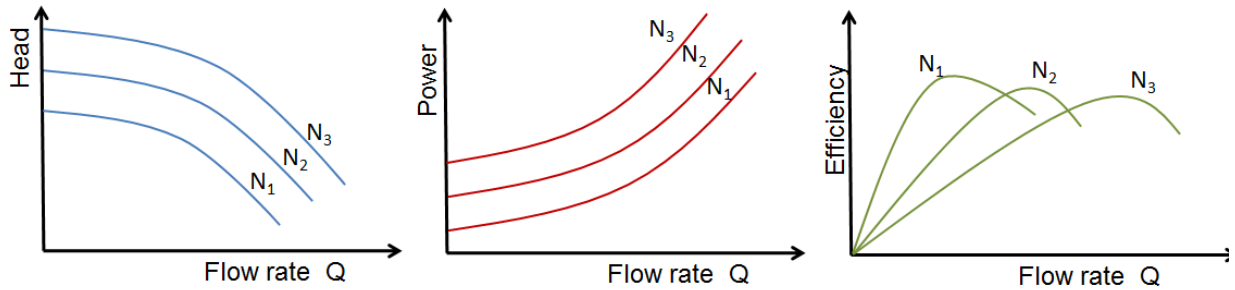

Figure 7.9. Influence of impeller speed on characteristic curves. The impeller speeds  $N_1 < N_2 < N_3$ .

Increasing the impeller diameter has a similar influence on the characteristic curves. Pump characteristic curves are usually available in manufacturer’s literature.

Before selecting a pump, the required capacity and the head has to be calculated by analysing the flow line. Following section explain how to analyse the pipe layout to calculate the system head requirement.

STEP INTO A WORLD OF OPPORTUNITY

[www.ecco.com/trainees](http://www.ecco.com/trainees)  
[trainees@ecco.com](mailto:trainees@ecco.com)





Please click the advert

Download free ebooks at [bookboon.com](http://bookboon.com)

### 7.3 Bernoulli's equation and system head

The conservation of the mechanical energy was discussed in chapter 4. The Bernoulli equation provides means to calculate pressure, velocity and datum heads. The influence of the viscous fluids on the kinetic energy was discussed in Chapter 6. The modified Bernoulli equation that accounts the viscous effects is given below.

$$\frac{P_1}{\rho g} + \alpha \frac{v_1^2}{2g} + z_1 = \frac{P_2}{\rho g} + \alpha \frac{v_2^2}{2g} + z_2 = E \quad (4.13b)$$

#### 7.3.1 Pump head requirements

Consider a typical pumping system that contains a reservoir from which the liquid is pumped from and a discharge reservoir in to which the liquid is pumped into with a pump placed in between as shown in Figure 7.10. All three are linearly connected using appropriate pipes and other fittings. Usually there should be two valves that isolate the two reservoirs from the rest

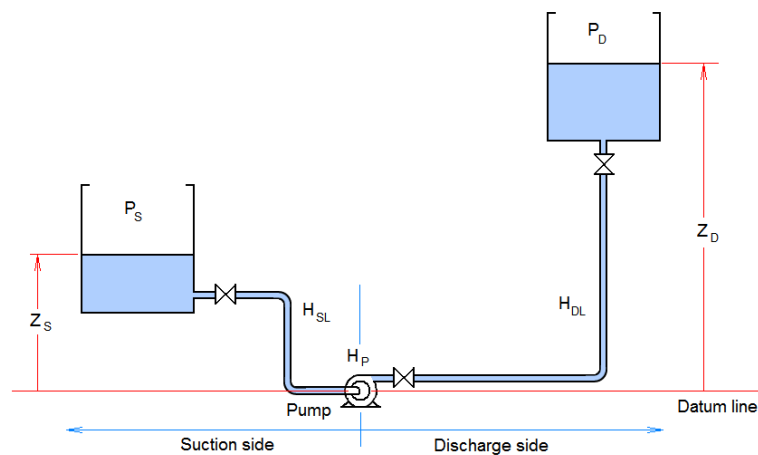

Figure 7.10. A typical pumping system

of the piping system and another valve immediately after the pump for throttling (throttling will be discussed separately). Consider a hypothetical vertical line that passes through the centre of the pump. The side on which the inlet line is called the suction side and all the variables on this side are denoted with a subscript “S”. The side to which the pump is pumping liquid is called the discharge side and the variables are denoted by a subscript D.

The elevation head is measured upwards from the arbitrarily selected datum line. It is customary to select the datum line to pass through the centre of the pump. The elevation head on suction and discharge sides are taken as  $Z_s$  and  $Z_D$  respectively. The pressure above the liquid level in the suction side is  $P_s$  and the pressure above the liquid level on the discharge side reservoirs is  $P_D$ . The losses in pipe lines were discussed in Chapter 6. These losses are due to the pipe friction and the fittings. Consider the suction side. There is a sudden contraction imparting head loss where the liquid enters the pipe. The head loss in the valve depends on the degree it is opened. There are two long radius bends causing head loss too. Total of all these losses in the suction side is taken as  $H_{SL}$ . Similarly the total head loss due to friction and fittings is denoted by  $H_{DL}$ .

Consider a fluid element starting at the free liquid surface in the suction reservoir that goes passing the pump to the free surface of the discharge reservoir. The total mechanical energy it possesses when it is at the suction side free surface is given by

$$E_S = \frac{P_S}{\rho g} + \alpha \frac{v_s^2}{2g} + Z_S \quad (7.1)$$

As this fluid particle flows through the suction side  $H_{SL}$  amount of head is lost due to the friction and fittings. The pump adds energy to this element as it passes through the pump. The amount of the energy it gains is the head provided by the pump  $H_P$ . Further  $H_{DL}$  amount of head is lost due to the friction and fittings on the discharge side. If we take the inventory for the head (energy per unit weight) the total head of the fluid element is given by

$$E_S - H_{SL} + H_P - H_{DL}$$

Since the energy is conserved, this should be equal to the energy of the fluid particle,  $E_D$ , when it is at the free surface of the discharge reservoir.

$$E_D = \frac{P_D}{\rho g} + \alpha \frac{v_D^2}{2g} + Z_D \quad (7.2)$$

Therefore,

$$E_S - H_{SL} + H_P - H_{DL} = \frac{P_D}{\rho g} + \alpha \frac{v_D^2}{2g} + Z_D \quad (7.3)$$

By substituting (7.1) in (7.3) and rearranging terms gives the following equation for the pump head

$$H_P = \frac{(P_D - P_S)}{\rho g} + \alpha \frac{(v_D^2 - v_s^2)}{2g} + (Z_D - Z_S) + (H_{DL} + H_{SL}) \quad (7.4)$$

Considering that the  $v_D$  and  $v_s$  in above equation refer to the velocities at the free surfaces of the reservoirs the difference  $(v_D^2 - v_s^2)$  can be neglected. The velocity is simply the time rate at which the liquid level drops in the suction side and the rate at which the liquid level rises in the discharge side. These are not considerably large values since the cross sectional areas of the two reservoirs are rather large compared to the pipe diameters used. Hence the difference is even smaller compared to the datum head difference and the losses. Therefore the equation (7.4) can be reduced to

$$H_P = \frac{(P_D - P_S)}{\rho g} + (Z_D - Z_S) + (H_{DL} + H_{SL}) \quad (7.5)$$

without losing the generality. However, it should be noted that this is subjected to the piping system under consideration.

Equation (7.5) could be rewritten as below.

$$H_P = \left( \frac{P_D}{\rho g} + Z_D + H_{DL} \right) - \left( \frac{P_S}{\rho g} + Z_S - H_{SL} \right) \quad (7.6a)$$



First term in equation (7.6) is called the discharge head and the second term is called the suction head.

$$\text{Suction head } H_S = \frac{P_S}{\rho g} + Z_S - H_{SL} \quad (7.6b)$$

$$\text{Discharge head } H_D = \frac{P_D}{\rho g} + Z_D + H_{DL} \quad (7.6c)$$

The difference between the discharge head and the suction head gives the required pump head to pump liquid from suction reservoir to discharge reservoir at a given flow rate. The head losses  $H_{SL}$  and  $H_{DL}$  increase with increasing flowrate. Hence it is evident from equation (7.6b) and (7.6c) that the suction head gets smaller and the required discharge head increases with the increasing flowrate.

Further simplification is possible if the reservoirs are open to the atmosphere. Then  $(P_D - P_S)$  vanishes. The equation (7.5) simplifies to

$$H_P = (Z_D - Z_S) + (H_{DL} + H_{SL}) \quad (7.7)$$

If the suction side reservoir is below the datum line, then  $Z_S$  is negative and in equation 4 the sum of the elevation is taken rather than the difference. The SI units of the pump head  $H_p$  is metres.

The head losses due to friction are to be calculated considering the wall roughness and the equivalent lengths of fittings in pipe diameters (or the number of velocity heads) using the Darcy's equation given in Chapter 6.

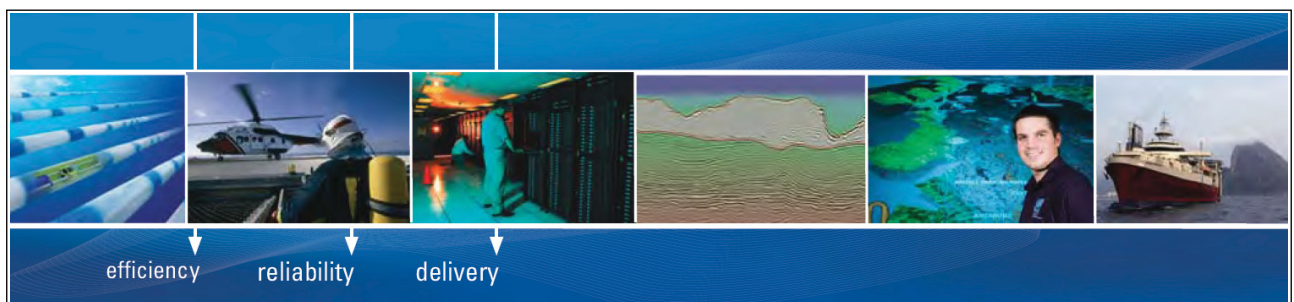

Please click the advert

As a leading technology company in the field of geophysical science, PGS can offer exciting opportunities in offshore seismic exploration.

We are looking for new BSc, MSc and PhD graduates with Geoscience, engineering and other numerate backgrounds to join us.

To learn more our career opportunities, please visit [www.pgs.com/careers](http://www.pgs.com/careers)

A Clearer Image  
[www.pgs.com](http://www.pgs.com)



$$\Delta P = 8\phi \frac{L_T}{D} \left[ \frac{\rho \bar{u}^2}{2} \right]$$

Head loss is given by

$$H = \frac{\Delta P}{\rho g} = 8\phi \frac{L_T}{D} \left[ \frac{\bar{u}^2}{2g} \right] \quad (7.8)$$

Where  $\phi$  is the friction factor that has to be determined using the Moody diagram. The head loss has to be calculated for suction and discharge sided considering the length of the pipe and the fittings.

For suction side

$$L_T = \begin{array}{l} \text{Length of the pipe between} \\ \text{the suction reservoir and the} \\ \text{pump inlet} \end{array} + \begin{array}{l} \text{Sum of equivalent lengths of} \\ \text{all fittings in the suction side} \end{array}$$

$L_T$  for the discharge side could be calculated using a similar approach considering the pipe length and the equivalent lengths of the fittings.

### 7.3.2 Power requirement

The pump head in this case is the energy received by a unit weight of the liquid. Therefore the hydraulic power input can be calculated by multiplying the pump head by the mass flowrate and the acceleration due to gravity.

$$P = H_p \dot{m} g \quad (7.9)$$

The mass flowrate can be expressed in terms of the density and the volumetric flowrate.

$$P = H_p \dot{Q} \rho g \quad (7.10)$$

$P$  is the amount of power received by the liquid. The shaft power,  $P_{Shaft}$ , could be calculated if the efficiency of the pump,  $\eta$  is known.

$$P_{Shaft} = \frac{P}{\eta} = \frac{H_p \dot{Q} \rho g}{\eta} \quad (7.11)$$

As discussed above, the efficiency is a function of the pump capacity.

### Example

Dilute sulphuric acid is to be pumped between two storage tanks using 800 m long pipe with 5 cm inner diameter at a rate of 10 tonn/h. The overall vertical difference between the liquid levels of the two tanks is 15m. The tanks are open to atmosphere through vents. The specific gravity of the acid is 1.3 and the viscosity is 0.001 Pa s. In the pipework there is



a globe valve (fully open, equivalent to 100 pipe diameters) and four 90° standard radius bends (30 pipe diameters each). The relative roughness of the pipe is 0.002. Any other losses can be considered negligible. What power requirement of the centrifugal pump used if the efficiency of the pump is 63%?

Answer

First, calculate the head that has to be provided by the pump using equation (7.5).

$$H_p = \frac{(P_D - P_S)}{\rho g} + (Z_D - Z_S) + (H_{DL} + H_{SL}) \quad (7.5)$$

The tanks are open to the atmosphere. Therefore,  $(P_D - P_S) = 0$ .

$$H_p = (Z_D - Z_S) + (H_{DL} + H_{SL}) \quad (A)$$

The overall vertical difference between the liquid levels in the two tanks is given as 15 m. Therefore,

$$(Z_D - Z_S) = 15m \quad (B)$$

Head losses due to friction and fittings have to be calculated. For this mean velocity and the friction factor are required.

a) Calculating mean velocity in the pipe:

$$\text{Mass flowrate} = 10 \frac{\text{Tonns}}{\text{hr}} = \frac{10 \times 1000 \text{ kg}}{3600 \text{ s}} = 2.78 \text{ kg s}^{-1}$$

$$\text{Volumetric flow rate} = \frac{\text{Mass flowrate}}{\text{density}} = \frac{2.78 \text{ kg s}^{-1}}{1300 \text{ kg m}^{-3}} = 0.0021 \text{ m}^3 \text{ s}^{-1}$$

$$\text{Mean velocity } U = \frac{\text{Volumetric flowrate}}{\text{Pipe cross sectional area}} = 1.07 \text{ m s}^{-1}$$

b) Finding friction factor

To find the friction factor, Moody diagram has to be used. The relative roughness is given as 0.002. Calculate the Reynolds number.

$$\text{Reynolds number} = \frac{\rho U D}{\mu} = \frac{1300 \times 1.07 \times 0.05}{0.001} = 69518$$

The flow is turbulent.

From the Moody diagram the friction factor,

c) Calculating head losses

The head losses are given by  $(H_{DL} + H_{SL})$ .

$$\begin{aligned}
 (H_{DL} + H_{SL}) &= \frac{\Delta P_{suction\ side}}{\rho g} + \frac{\Delta P_{discharge\ side}}{\rho g} \\
 &= 8\phi \frac{U^2}{2g} \left[ \frac{L_T}{D} \right]_{Suction\ side} + 8\phi \frac{U^2}{2g} \left[ \frac{L_T}{D} \right]_{Discharge\ side} \\
 &= 8\phi \frac{U^2}{2g} \left( \left[ \frac{L_T}{D} \right]_{Suction\ side} + \left[ \frac{L_T}{D} \right]_{Discharge\ side} \right)
 \end{aligned}$$

For the pipe  $\frac{L}{D} = 16000$

Globe valve  $\frac{L}{D} = 100$

Four bends  $\frac{L}{D} = 120$

Exit losses at the suction tank  $\frac{L}{D} = 25$

Entry losses at the discharge tank  $\frac{L}{D} = 50$

Total equivalent length of pipe line in terms of number of diameters is

$$\left( \left[ \frac{L_T}{D} \right]_{Suction\ side} + \left[ \frac{L_T}{D} \right]_{Discharge\ side} \right) = 16295$$

Therefore the total head loss is

$$\begin{aligned}
 (H_{DL} + H_{SL}) &= 8\phi \frac{U^2}{2g} \left( \left[ \frac{L_T}{D} \right]_{Suction\ side} + \left[ \frac{L_T}{D} \right]_{Discharge\ side} \right) \\
 &= 8 \times 0.0031 \times 16295 \times \frac{1.07^2}{2 \times 9.81}
 \end{aligned}$$

$$(H_{DL} + H_{SL}) = 23.6\ m$$

Therefore the required pump head

$$H_p = (Z_D - Z_s) + (H_{DL} + H_{SL}) = 15\ m + 23.6\ m = 38.6\ m$$

d) The power requirement calculation

The hydraulic power the pump has to produce = Total head  $\times$  mass flowrate  $\times g$

$$= 38.6 \times 2.78 \times 9.81\ W$$

$$= 1.053\ kW$$

The efficiency is given as 63%

$$\text{Therefore the power requirement} = \frac{937.6}{0.63} = 1.67\ kW$$

### 7.4 System curve

To decide on the pump head, knowledge on the piping layout is essential. The location of the reservoirs (tanks), pipe length and diameter, types of bends and valves to be used, operating conditions including the most severe demands has to be considered before selecting the pump.

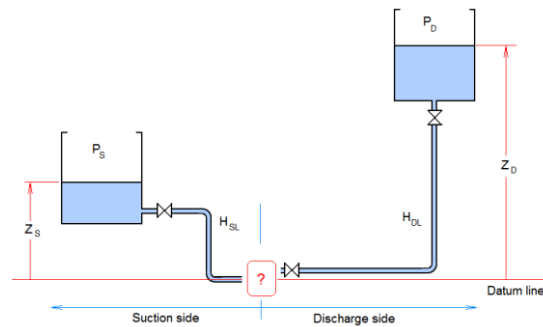

Figure 7.11. Piping system analysis

Consider the piping system shown in Figure 7.11. The suction and discharge side layout is shown. At the design stage of a process plant piping and instrumentation diagrams are developed considering the location of all equipment distributed in many floors if that is the case. Therefore, the elevation above or below the arbitrarily selected datum line could be calculated.

The layout shows how the pipes would be laid together with fittings. The suction side head available is given by the equation (7.6b) and the equation (7.6c) gives the head requirement on discharge side. The difference gives the “extra” head needed to pump the liquid from the suction reservoir to the discharge reservoir. The head required by this system is given by the difference between the discharge head and the suction head.

Therefore, the system head required is given by

$$\Delta H = H_D - H_S \tag{7.12}$$

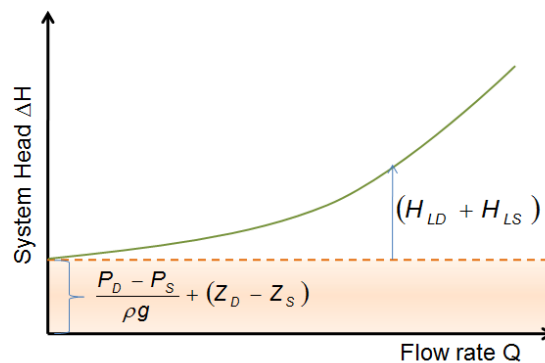

Figure 7.12. System curve

By substituting for  $H_D$  and  $H_S$  using equations (7.6b) and (7.6c) an expression for  $\Delta H$  can be achieved.

$$\Delta H = \frac{(P_D - P_S)}{\rho g} + (Z_D - Z_S) + (H_{DL} + H_{SL}) \quad (7.13)$$

Pressure head difference and the elevation head difference are constants decided by the operational conditions and the piping layout of the plant and hence do not depend on the flow rate.

Therefore,  $\frac{(P_D - P_S)}{\rho g} + (Z_D - Z_S)$  is called the static head. However, the total friction head loss,  $(H_{DL} + H_{SL})$ , depends on the flowrate as it is a function of velocity through Darcy's equation. This term is called the dynamic head loss. The plot of the system head  $\Delta H$  against the flowrate (known as the system curve) is shown in Figure 7.12.

To generate the system curve the head loss due to the friction at various flowrates has to be computed. Since the characteristic parameters of the piping system such as the pipe diameter and the number of fittings are known at this stage, the curve can be easily constructed by calculating one total head loss, say  $(H_{DL} + H_{SL})_1$ , using the Moody diagram for an arbitrary flowrate  $Q_1$  and then computing the subsequent head losses using the following equation.

$$(H_{DL} + H_{SL})_2 = (H_{DL} + H_{SL})_1 \left[ \frac{Q_2}{Q_1} \right]^2 \quad (7.14)$$

Exercise: Derive equation (14) by applying equation (8) to the piping system shown in Figure 7.11.

Please click the advert



## Going up in the world...

You'll be going up in the world after graduating from Nottingham Trent University. We are one of the best universities in England for graduate employment with over 97% of our students employed or in further study within six months of graduating.\*

- Consistently ranked as one of the leading modern universities in *The Independent Good University Guide*.
- Courses informed by businesses and industry – strong commercial partnerships with over 6,000 companies globally.
- Many courses include professional accreditation and / or the opportunity to undertake a work placement. This gives our graduates a competitive edge when entering the job market.
- An exciting student city in the middle of England. Ideally located for travel across the UK and with direct flights to destinations across Europe from East Midlands Airport.
- Investing £130 million across our three campuses to create an inspiring learning environment.
- In the most recent QAA institutional review, the University received the highest commendation for its consistent commitment to supporting students and their learning.

If you would like any guidance on applying to Nottingham Trent University please contact Laura Vella, our International Officer for Europe, on

Tel: +44 (0)115 848 8180

Email: [laura.vella@ntu.ac.uk](mailto:laura.vella@ntu.ac.uk)

[www.ntu.ac.uk/book](http://www.ntu.ac.uk/book)

**NOTTINGHAM**  
TRENT UNIVERSITY

5365/07/09

\* HESA DHLE 2006-07

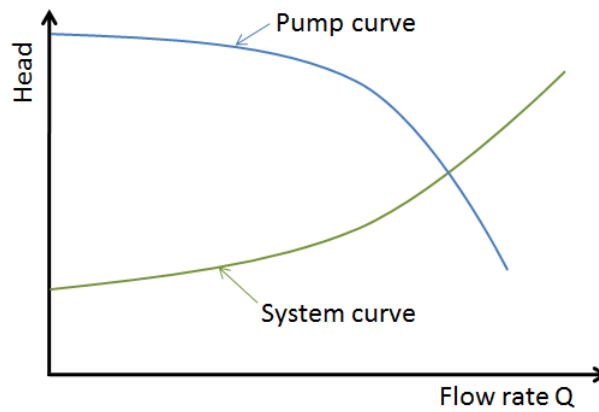

Figure 7.13. System and Pump head curves against

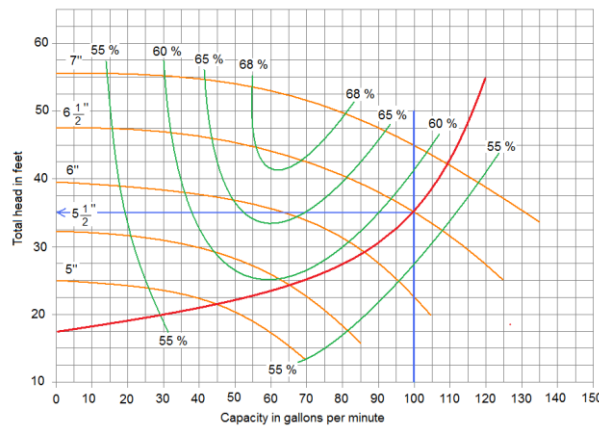

Figure 7.14. Pump selection criterion

System head curve shows the head requirement to generate the required range of flowrates. The pump curve (shown in figure 7.7) gives the range of heads produced by a centrifugal pump for various flowrates. Figure 7.13 shows the system curve and the pump curve on the same plot.

The two curves intersect at a particular flowrate. This is the maximum flowrate the pump can generate and hence the maximum capacity of the pump. For flowrates below this value, the pump throws up a higher head than required and flowrates above this value result in a pump head less than the system head requirement. Hence for any particular piping system a centrifugal pump can operate only at the point where the curves intersect.

The system curve is fixed for the selection of piping system and the flowrate is decided by the process requirements. Therefore, a pump with the performance curve that would intersect the system curve at the (or closer to the) required flowrate has to be selected. Pump manufacturers publish the pump curves in their literature. One such family of curves is shown in Figure 7.14. The plot is for a series of pumps with a fixed speed of 2600 rpm. The pump curves for a range of impeller diameters (5 inch to 7 inch in increments of 0.5 inch) are shown together with efficiency curves (for efficiencies ranging from 55% up to 68%).

Super imposed on the pump curve plot is the system curve (in green). The vertical line shows the required flowrate (in US gallons). Suppose the process this piping system is used requires a flow rate of 100 gallons per minute. At the required flowrate the head requirement is 35 feet. Closer inspection of the plot shows that a centrifugal pump with a 6.6 inch diameter impeller would be the best selection for this system. The selected pump would operate at an efficiency of 58% pumping 100 gallons.

## 7.5 Net Positive Suction Head (NPSH)

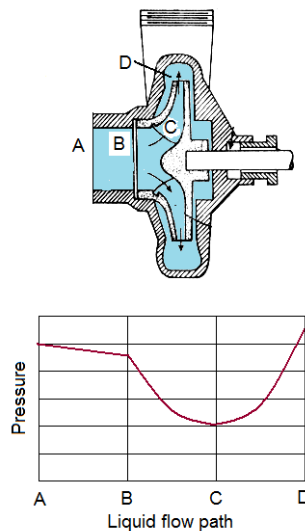

**Figure 7.15.** Pressure variation within a centrifugal pump

In centrifugal pumps the pressure head is developed by converting the kinetic head the impeller provided to the liquid. Even though a higher pressure materialised at the outlet port, within the pump the static pressure is lower. Figure 7.15 shows the pressure variation along the path of the fluid. The inlet (A) pressure (which, in reality is suction) drops further due to the nozzle friction towards the impeller. The pressure drops to its minimum in the vanes (C) as the fluid speeds up. As the fluid leaves the impeller the static pressure begins to increase at the expense of the kinetic energy. The head available at the inlet is the suction head  $H_S$ . This could be small and as a result, the pressure inside the pump could fall below the vapour pressure of the liquid generating vapour bubbles. This is known as *cavitation*.

$$H_S = \frac{P_S}{\rho g} + Z_S - H_{SL} \quad (7.6b)$$

To avoid cavitation the suction head at the inlet flange must be greater than the vapour pressure head  $\frac{P_{vap}}{\rho g}$ . The difference between the  $H_s$  and the vapour pressure head is called the Net Positive Suction Head (NPSH).

$$NPSH = H_s - \frac{P_{vap}}{\rho g} \quad (7.15a)$$

$$NPSH = \frac{P_s - P_{vap}}{\rho g} + Z_s - H_{SL} \quad (7.15b)$$

To prevent cavitation  $NPSH > 0$ . To make sure that this is the case, pump manufacturers define a margin by how much the suction head must exceed the vapour pressure head. This is called the NPSH required. Once the piping layout is known the NPSH available in the system could be calculated. The NPSH available must be greater than the NPSH required by the pump. The NPSH required increases with the increasing flowrate. This is shown in Figure 7.8. Note that almost all pump manufacturers use water as the test fluid and NPSH required defined for water at the operating temperature. Pay attention to the NPSH if the pump is to be used on a liquid other than water, especially low volatile liquids.

### Example

- a) A centrifugal pump with an NPSH requirement of 5.8m is to be used to pump 160m<sup>3</sup>/hr of saturated water at 120 °C. The minimum liquid level in the suction vessel is expected to be 7.5m above the pump inlet. The total equivalent length of the pipe (after compensating for the fittings) is 22m. The absolute roughness of the pipe is 0.046mm. Available pipe diameters are 200mm, 150mm, and 100mm. Select the appropriate pipe diameter that would make the satisfactory suction piping. Assume that the viscosity and the density of the water remain constant at 0.001Pa s and 1000kg m<sup>-3</sup> respectively.

Please click the advert



STUDY.

The stuff you'll need to make a good living



PLAY.

The stuff that makes life worth living

NORWAY.  
YOUR IDEAL STUDY DESTINATION.

WWW.STUDYINNORWAY.NO  
FACEBOOK.COM/STUDYINNORWAY



Download free ebooks at [bookboon.com](http://bookboon.com)

## Answer

For safe operation of the pump NPSH available should be greater than NPSH required  
 $NPSHA \geq NPSHR$

It is given that  $NPSHR = 5.8 \text{ m}$

Flowrate =  $160 \text{ m}^3/\text{hr} = 0.44 \text{ m}^3/\text{s}$

$Z_s = 7.5 \text{ m}$

Equivalent length of the pipe =  $22 \text{ m}$

Pipe roughness  $\epsilon = 0.046 \text{ mm}$

Liquid: Saturated water at  $120 \text{ }^\circ\text{C}$

$$NPSHA = \frac{P_s}{\rho g} + Z_s - H_{LS} - \frac{P_{vp}}{\rho g} \quad (\text{e1})$$

For saturated water,  $P_s = P_{vp}$

$$\text{Therefore } \left( \frac{P_s - P_{vp}}{\rho g} \right) = 0$$

Therefore,  $NPSHA = Z_s - H_{LS}$

The requirement for safe operation is  $NPSHA \geq NPSHR$

$$Z_s - H_{LS} \geq 5.8 \text{ m}$$

$$7.5 - H_{LS} \geq 5.8 \text{ m} \quad (\text{e2})$$

HLS has to be computed for given pipe diameters and check against the equation (e2) to see which one satisfy the inequality.

$$H_{LS} = \frac{\Delta P_f}{\rho g} = 8f \left[ \frac{L}{D} \right] \frac{u^2}{2g} \quad (\text{e3})$$

$$u = \left[ \frac{Q}{3600} \right] \frac{4}{\pi D^2} \quad (\text{e4})$$

$$Re = \frac{\rho D u}{\mu} \quad (\text{e5})$$

$$\rho = 1000 \text{ kg/m}^3 \quad \mu = 0.001 \text{ Pa s}$$

D/[mm]	u/[m/s]	Re	$\epsilon/D$	8f	$H_{LS}/[\text{m}]$	$(7.5 - H_{LS})/[\text{m}]$
200	1.40	$2.8 \times 10^5$	0.00023	$1.64 \times 10^{-3}$	0.18	7.32
150	2.49	$3.7 \times 10^5$	0.0003	$1.66 \times 10^{-3}$	0.77	6.73
100	5.66	$5.7 \times 10^5$	0.0004	$1.69 \times 10^{-3}$	5.94	1.56

D=150mm and 200mm fulfils the requirement. Usual practice is to keep NPSHA 0.5 to 1.0m above the NPSHR.

Therefore, D=150 is suitable for this application.



## 7.6 Flow Control

When using pumps to move liquid between process vessels, flow rates has to be controlled. In some cases a certain flowrate has be achieved but finding a pump may be difficult. There may be instances where one has to increase the flowrate economically or achieve higher heads than an individual pump could provide. How to address these problems are explained below.

### 7.6.1 Throttling

Consider the system curve. The curve is dependent on the head losses. Therefore, by changing the pressure drop the steepness of the curve could be changed. As the pressure drop increases the steepness increases. This is achieved by opening or closing a valve downstream of the pump. Valve that is used to control the flow is called the throttle valve and controlling the head in such a manner is called throttling. This valve is shown immediately of the pump in Figure 10.

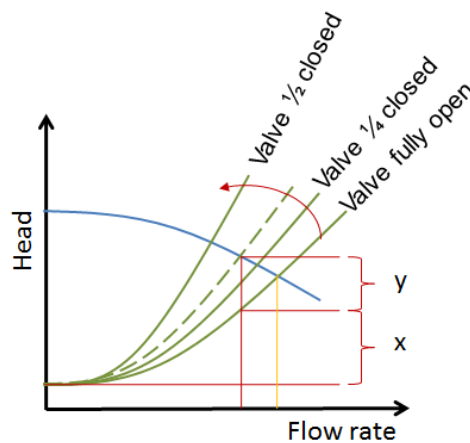

**Figure 7.16.** Impact of throttling on the system curve

When the throttle valve closes the point at which the system curve intersect the pump curve moves to the left as shown in the figure 7.16. The head is gained at the expense of the flow rate.

Throttling can be used to reduce cavitation. Further it could be used to achieve higher heads or to use a higher capacity pumps to achieve the head requirement at given flowrate. For throttling to work effectively at normal flowrate, it must account for at least 1/3 of the total dynamic head loss.

$$\frac{y}{x+y} \geq 0.33 \quad (7.16)$$

### 7.6.2 Varying pump speed

Flowrate can be increased by increasing the speed of the impeller. Variable speed pumps are normal centrifugal pumps fitted with variable speed motors. The speed of the motor is controlled through an inverter that controls the current to the motor.

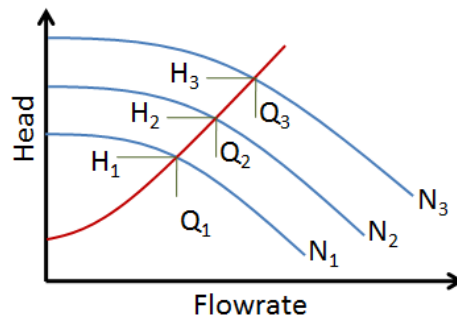
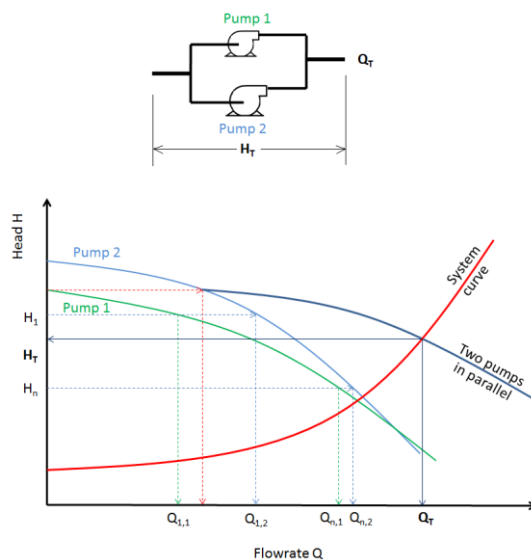

**Figure 7.17.** pump curves corresponding to various pump speeds

Figure 7.17 shows the pump curves for a pump operating at three different speeds.  $N_1$  is the lowest speed and  $N_3$  is the highest. At the speed  $N_1$ , the flow rate and the head achieved are  $Q_1$  and  $H_1$  respectively. As the pump speed increased to  $N_2$ , both the flowrate and the head increases to  $H_2$  and  $Q_2$ . Heads develop at these speeds are just sufficient to create required flows. This technique is more economical with regard to power consumption than discharge throttling but the variable speed drivers tends to be expensive.

### 7.6.3 Pumps in Parallel

Consider two pumps operating in parallel. The total head  $H_T$  of the combined system is as same as that of any individual pump. The flowrate of the combined system is given by the sum of the flowrates of each pump at the given flowrate. Therefore this combination is useful to increase the flowrate of the system.



**Figure 7.18.** Two pumps in parallel

Head	Total Flowrate
$H_1$	$Q_{T1} = Q_{1,1} + Q_{1,2}$
$H_2$	$Q_{T2} = Q_{2,1} + Q_{2,2}$
$\vdots$	$\vdots$
$H_n$	$Q_{Tn} = Q_{n,1} + Q_{n,2}$

**Table 7.1.** flowrates at various heads for two pumps in parallel.

$$H_T = H_1 = H_2 \quad (7.17)$$

$$Q_T = Q_1 + Q_2 \quad (7.18)$$

To find the operating characteristic of the system that uses two pumps in parallel the characteristics of each individual pump is needed. Figure 7.18 shows how to establish the characteristics of the combined system. First plot the individual pump curves for the two pumps. For a range of head values  $H_1, \dots, H_n$ , shown by the dashed lined on the plot, corresponding flowrates for the pump 1,  $Q_{1,1}, \dots, Q_{n,1}$ , and for the pump 2,  $Q_{1,2}, \dots, Q_{n,2}$ , can be found. The total flowrates corresponding to all the head values could be calculated using equation 7.18. Table 7.1 shows some of the values.

Using the values computed the pump curve for the parallel combination could be plotted as shown in Figure 7.18. The operating point for the system can be established by plotting the system curve on the same plot and finding the head and the flowrate at the point where the two curves intersect.

#### 7.6.4 Pumps in series

When two pumps are connected in series, there would not be an increase to the flow rate but would see an increase to the total head the combine system would produce. The operating conditions could be calculated by using the individual pump characteristics.

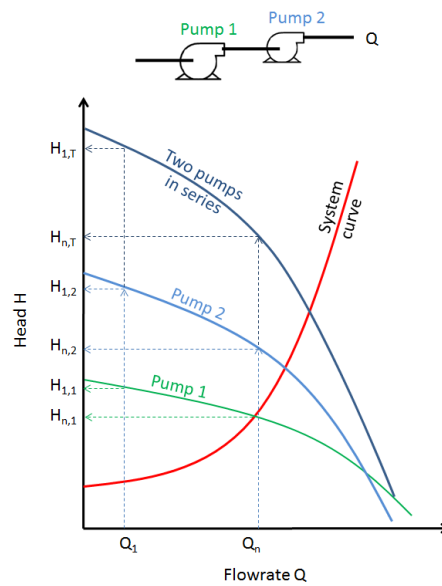

Figure 7.19. Two pumps in parallel

Consider two pumps connected in series. The pump curves are shown in Figure 7.19. A line drawn parallel to the vertical axis at a flowrate  $Q_1$  intersects the two pump curves giving the head each pump would produce. Consider  $H_{1,1}$  and  $H_{1,2}$  are the heads produced by pump 1 and 2 at the flowrate  $Q_1$ . The total head the two pumps connected in series throw is

$$H_{1,T} = H_{1,1} + H_{1,2}$$

For the range of the flowrates of the two pumps the total heads that can be achieved when they are connected in series could be calculated using the equation (7.19). The resulting  $H$  vs  $Q$  line is shown in Figure 7.19. The operating point of the combine system can be found by plotting the system curve on the same plot as shown in Figure 7.19. The intersection point between the head vs the flowrate curve for the pump combination and the system curve gives the operating point for the system.

## 7.7 Some remarks on practical issues

- Pump suction lines should be generously sized, say maximum velocity 1.5 m/s
- Installing strainers at the suction port is a good engineering practice (take this into account in the head calculations)
- Centrifugal pumps must be primed before the start
- The electric motors are normally chosen with a rated power output 20-30% greater than the pump consumption. This allows for a start-up power surge.
- Sometimes a water hammer will vibrate the whole piping system at the start of the pump. To reduce the possibility, shut the throttle valve fully before starting the pump and then open the valve fully (or up to the appropriate throttling position) gradually. This makes the pump to operate along the  $H$ - $Q$  curve preventing the water hammer.

## References

1. Karassik, I.J, Messina, J.P, Cooper, P, and Heald, C.C., Pump Handbook, 4th Ed., McGraw-Hill, 2008.
2. Coulson, J.M., Richardson, J.F., J R Backhurst and J H Harker, Chemical Engineering Vol 1, 6th Ed., Butterworth-Heinemann, 1999.
3. Holland, F. and Bragg R., Fluid flow for Chemical Engineers, 2nd Ed., Butterworth-Heinemann, 1995.

Please click the advert



## Are you considering a European business degree?

**LEARN BUSINESS** at university level. We mix cases with cutting edge research working individually or in teams and everyone speaks English. Bring back valuable knowledge and experience to boost your career.

**MEET** a culture of new foods, music and traditions and a new way of studying business in a safe, clean environment – in the middle of Copenhagen, Denmark.

**ENGAGE** in extra-curricular activities such as case competitions, sports, etc. – make new friends among CBS' 18,000 students from more than 80 countries.

**Copenhagen Business School**  
HÅNDELSSHØJSKOLEN

EFMD **EQUIS** AACSB ACCREDITED BY ASSOCIATION OF MBAs CEMS EQUIS ACCREDITED

See what we look like and how we work on [cbs.dk](http://cbs.dk)