



# Handbook of Mechanical Ventilation

**A User's Guide**

Established in 2003 **The Intensive Care Foundation** is the research arm of the **Intensive Care Society**. The Foundation facilitates and supports critical care research in the UK through the network of collaborating intensive care units with the aim of improving the quality of care and outcomes of patients in intensive care.

The Foundation coordinates research that critically evaluates existing and new treatments used in intensive care units with a particular focus on important but unanswered questions in intensive care. The targets for research are set by our Directors of Research, an expert Scientific Advisory Board and finally a consensus of the membership of the Intensive Care Society.

The Foundation also sponsors several annual awards to encourage and help train young doctors to do research. The outcomes from these research projects are presented at our national "State of the Art" Intensive Care meeting in December of each year. These include the Gold Medal Award and New Investigators Awards.

**The Intensive Care Foundation**

# **Handbook of Mechanical Ventilation**

**A User's Guide**

First published in Great Britain in 2015  
by the Intensive Care Society on behalf of  
the Intensive Care Foundation  
Churchill House,  
35 Red Lion Square,  
London WC1R 4SG

Copyright © 2015 The Intensive Care Foundation

All rights reserved. No part of this publication may be reproduced, stored in a retrieval system, or transmitted, in any form or by any means, electronic, mechanical, photocopying, recording or otherwise, without prior written permission of the publisher and copyright owner.

ISBN 978-0-9555897-1-3

Produced by Pagewise  
[www.pagewise.co.uk](http://www.pagewise.co.uk)

Art direction and coordination  
Mónica Bratt

## Contents

<b>Preface</b>	<b>9</b>
<b>Contributors</b>	<b>10</b>
<b>Symbols and abbreviations</b>	<b>11</b>
<b>1 Anatomy and physiology</b>	<b>13</b>
Structure and function of the respiratory system	13
Ventilation	14
Dead Space	15
Ventilation/perfusion matching	16
Control of breathing	20
<b>2 Respiratory failure</b>	<b>21</b>
Hypoxaemic (type I) respiratory failure	22
Hypercapnic (type II) respiratory failure	24
<b>3 Arterial blood gas analysis, oximetry and capnography</b>	<b>29</b>
Acid-base balance and buffering	29
Metabolic acidosis	30
Respiratory acidosis	31
Metabolic alkalosis	32
Respiratory alkalosis	32
Arterial blood gas (ABG) analysis	32
Arterial oxygen saturation and content	36

<b>Capnography</b>	<b>39</b>
Clinical applications	40
<b>4 Supplemental oxygen therapy</b>	<b>44</b>
Classification of O <sub>2</sub> delivery systems	47
<b>5 Humidification</b>	<b>51</b>
Passive devices	51
Active devices	53
<b>6 Assessing the need for ventilatory support</b>	<b>55</b>
Assisting with oxygenation	55
Assisting with CO <sub>2</sub> clearance	57
Assisting with the agitated patient	58
<b>7 Continuous positive airway pressure (CPAP)</b>	<b>59</b>
<b>8 Non-invasive ventilation (NIV)</b>	<b>65</b>
Equipment	66
Indications for NIV	67
Contraindications to NIV	69
Practical NIV issues	70
Complications of NIV	71
Cardiovascular effects of positive pressure ventilation	71
<b>9 Artificial airways</b>	<b>74</b>
Endotracheal tubes	74
Correct position	75
Endotracheal tubes and work of breathing	76
Endotracheal tubes and ventilator-associated pneumonia (VAP)	76
<b>10 Cricothyroidotomy</b>	<b>78</b>

<b>11 Tracheostomies</b>	<b>83</b>
Advantages of tracheostomy	83
Techniques of insertion	84
Complications	85
Cuffed and uncuffed tubes	86
Fenestrated and non-fenestrated tubes	87
Subglottic suction ports	88
Speaking valves	88
<b>12 Invasive positive pressure mechanical ventilation</b>	<b>89</b>
Modes of ventilatory support	90
Inspiratory time and I:E ratio	107
<b>13 Typical ventilator settings</b>	<b>109</b>
<b>14 Care of the ventilated patient</b>	<b>114</b>
Analgesia, sedation and paralysis	114
Pressure area care	124
Eye care	124
Mouth care	124
Airway toilet	125
Stress ulcer prevention	125
<b>15 Hospital acquired pneumonia (HAP)</b>	<b>126</b>
<b>16 Ventilator-associated pneumonia (VAP)</b>	<b>127</b>
<b>17 Ventilator troubleshooting</b>	<b>130</b>
Basic rules	130
Desaturation and hypoxia	131
Patient-ventilator asynchrony	137
<b>18 Adjuncts to care in ventilated patients</b>	<b>148</b>
Nebulisers	148

	<u>Airway humidification/ heat and moisture exchangers</u>	<u>151</u>
<b>19</b>	<b><u>Weaning</u></b>	<b><u>153</u></b>
	<u>Assessing suitability to wean</u>	<u>154</u>
	<u>Assessing suitability for extubation</u>	<u>156</u>
	<u>Difficulty in weaning</u>	<u>159</u>
<b>20</b>	<b><u>Extubation</u></b>	<b><u>164</u></b>
<b>21</b>	<b><u>Ventilatory support in special circumstances</u></b>	<b><u>167</u></b>
	<u>Asthma</u>	<u>167</u>
	<u>Chronic obstructive pulmonary disease (COPD)</u>	<u>172</u>
	<u>Acute respiratory distress syndrome (ARDS)</u>	<u>176</u>
	<u>Cardiogenic shock</u>	<u>180</u>
	<u>Community acquired pneumonia (CAP)</u>	<u>182</u>
<b>22</b>	<b><u>Extracorporeal support</u></b>	<b><u>185</u></b>
	<u>Extracorporeal membrane oxygenation (ECMO)</u>	<u>185</u>
	<u>Extracorporeal CO<sub>2</sub> removal (ECCO<sub>2</sub>R)</u>	<u>186</u>
	<b><u>Additional reading</u></b>	<b><u>188</u></b>

## Preface

Respiratory problems are commonplace in the emergency department and on the general and specialist wards, and the need for advanced respiratory support represents the most common reason for admission to intensive care. An understanding of the approach to patients with respiratory failure and of the principles of non-invasive and invasive respiratory support is thus essential for healthcare professionals, whether nurses, physiotherapists, or doctors.

When one of the authors of this book began his ICU career, he sought a short ‘primer’ on mechanical ventilation. None existed. Worse, this remains true some 25 years later. This handbook is designed to fill that gap, telling you ‘most of what you need to know’– in a simple and readable format. It is not meant to be exhaustive, but to be a text which can be read in a few evenings and which can then be dipped into for sound practical advice.

We hope that you will find the handbook helpful, and that you enjoy working with the critically ill, wherever they may be.

The authors, editors and ICF would like to thank Maquet for providing the unconditional educational grant without which the production of this book was made possible. No payments were made to any authors or editors, and all profits will support critical care and respiratory-related research.

*The Authors*

## Contributors

### Primary Authors

**Hugh Montgomery** FRCP MD FFICM  
Professor of Intensive Care Medicine,  
University College London, UK;  
Consultant Intensivist, Whittington  
Hospital, London, UK.

**Luigi Camporota** MD, PhD, FRCP, FFICM  
Consultant Intensivist, Guy's & St  
Thomas' NHS Foundation Trust.

**Orhan Orhan** MB BS, BSc, MRCP, FHEA  
Specialist Registrar in Respiratory and  
General Medicine,  
Northwest Thames Rotation, London.

**Danny J. N. Wong** MBBS, BSc, AKC, MRCP,  
FRCA  
Specialist Registrar in Anaesthetics  
and Intensive Care Medicine,  
King's College Hospital.

**Zudin Puthuachary** MBBS BMedSci. MRCP  
EDICM D.UHM PGCME FHEA PhD  
Consultant, Division of Respiratory  
and Critical Care Medicine, University  
Medical Cluster, National University  
Health System, Singapore.  
Assistant Professor, Department of  
Medicine, Yong Loo Lin School of  
Medicine, National University of  
Singapore, Singapore.

**David Antcliffe** MB BS BSc MRCP  
Intensive Care and Acute Medicine  
Registrar, Clinical Research Fellow,  
Imperial College London.

**Amanda Joy** MBBS BSc MRCP DCH DRCOG  
Specialist Registrar in General Practice,  
North East London.

**Sarah Benton Luks** MBBS DRCOG BSc  
GPVTS ST2, sarahluks@gmail.com

**Megan Smith** LLB, MBBS, FRCA  
Specialist Registrar in Anaesthesia and  
Paediatric Critical Care,  
Barts and the London NHS Trust,  
Whitechapel, London.

**Tony Joy** MBChB MRCS(Eng) DCH FCEM  
PGCert  
Registrar, London's Air Ambulance and  
Barts Health NHS Trust.

**Julia Bichard** BM BCh MA MRCP  
Specialist Registrar in Palliative Medicine,  
North East London Deanery.

**Vishal Nangalia** BSc MBChB FRCA; MRC  
Clinical Research Training Fellow at UCL;  
ST7 Anaesthetics,  
Royal Free Hospital NHS Trust, London.

**Katarina Zadrzilova** MD  
Consultant in Anaesthesia and Intensive  
care. The University Hospital Brno,  
Czech Republic.

**Ian S Stone** MRCP MBBS BSc  
SPR Respiratory Medicine,  
St Bartholomew's Hospital.

**Petr Dlouhy** MD

### Senior Editors

**Luigi Camporota**  
**Hugh Montgomery**  
**Petr Dlouhy**

### Editors

**Stephen Brett**  
**Tim Gould**  
**Peter McNaughton**  
**Zudin Puthuachary**  
**Vishal Nangalia**

## Symbols and abbreviations

<b>ABG</b>	Arterial blood gas	<b>EPAP</b>	Expiratory positive airway pressure
<b>AC</b>	Assist-control ventilation	<b>ERV</b>	Expiratory reserve volume
<b>ACT</b>	Activated clotting time	<b>ETT</b>	Endotracheal tube
<b>APRV</b>	Airway pressure release ventilation	<b>FiO<sub>2</sub></b>	Fractional concentration of inspired oxygen
<b>APTT</b>	Activate partial thromboplastin time	<b>FRC</b>	Functional residual capacity
<b>ARDS</b>	Acute respiratory distress syndrome	<b>GBS</b>	Guillan Barre Syndrome
<b>ASB</b>	Assisted spontaneous breathing	<b>HFOV</b>	High frequency oscillatory ventilation
<b>BiPAP</b>	Bilevel positive airway pressure	<b>HME</b>	Heat and moisture exchanger
<b>CaO<sub>2</sub></b>	Arterial oxygen content	<b>I:E ratio</b>	Ratio of time spent in inspiration to that spent in expiration
<b>CI</b>	Cardiac index	<b>IC</b>	Inspiratory capacity
<b>CMV</b>	Continuous mandatory ventilation	<b>IPAP</b>	Inspiratory positive airway pressure
<b>CO</b>	Cardiac output	<b>IPPV</b>	Intermittent positive pressure ventilation
<b>CO<sub>2</sub></b>	Carbon dioxide	<b>kPa</b>	KiloPascal
<b>COHb</b>	Carboxyhaemoglobin	<b>mP<sub>aw</sub></b>	Mean airway pressure
<b>COPD</b>	Chronic obstructive pulmonary disease	<b>MV</b>	Minute ventilation
<b>CPAP</b>	Continuous positive airway pressure	<b>NAVA</b>	Neurally adjusted ventilator assist
<b>CXR</b>	Chest x-ray	<b>NIV</b>	Non-invasive ventilation
<b>DO<sub>2</sub>l</b>	Oxygen delivery index	<b>O<sub>2</sub></b>	Oxygen
<b>ECCO<sub>2</sub>R</b>	Extracorporeal carbon dioxide removal	<b>O<sub>2</sub>ER</b>	Oxygen extraction ratio
<b>ECMO</b>	Extracorporeal membrane oxygenation	<b>OI</b>	Oxygen Index

P(A-a)	Alveolar-arterial Oxygen gradient	RR	Respiratory rate
PA	Pulmonary arteries	RV	Residual volume
P <sub>a</sub>	Arterial pressure	SaO <sub>2</sub>	Percentage saturation of arterial haemoglobin with oxygen
PaCO <sub>2</sub>	Partial pressure of carbon dioxide in arterial blood	SBT	Spontaneous breathing trial
PACO <sub>2</sub>	Alveolar partial pressure of carbon dioxide	SIMV	Synchronised intermittent mandatory ventilation
P <sub>alv</sub>	Alveolar pressure	SvO <sub>2</sub>	Percentage saturation of mixed venous blood with oxygen
PaO <sub>2</sub>	Partial pressure of oxygen in arterial blood	TLC	Total lung capacity
PEEP	Positive end expiratory pressure	V:Q	Ratio of pulmonary ventilation to perfusion
P <sub>plat</sub>	Plateau pressure	V <sub>A</sub>	Alveolar ventilation
PS	Pressure support ventilation	VAP	Ventilator-associated pneumonia
P <sub>v</sub>	Venous pressure	VC	Vital capacity
Q	Flow	VCO <sub>2</sub>	Carbon dioxide production
Q <sub>c</sub>	Capillary blood flow	V <sub>D</sub>	Dead space volume
Q <sub>s</sub>	Right ventricular output which bypasses the lungs ventilatory units	VE	Expired minute ventilation
Q <sub>s</sub> /Q <sub>t</sub>	Pulmonary shunt fraction	VO <sub>2</sub>	Oxygen consumption
Q <sub>t</sub>	Cardiac output	V <sub>T</sub>	Tidal volume

# 1 Anatomy and physiology

## We offer ventilatory support to:

- 1 Relieve the distress of dyspnoea
- 2 Reduce the work of breathing
- 3 Improve oxygenation
- 4 Improve CO<sub>2</sub> clearance
- 5 Provide some combination of the above

In our efforts, we must compensate for any loss of airway warming and humidifying functions.

## Structure and function of the respiratory system

As components of the respiratory system, the airways must *WAF*T Air (*Warm and Filter Tropical [humidified] Air*), and the lungs exchange CO<sub>2</sub> (from blood to alveoli) and O<sub>2</sub> (from alveoli to blood).

*Warming* occurs predominantly in the naso-pharynx. *Filtration* removes particulate matter (soot, pollen) that is trapped by nasal hairs, and by pharyngeal and airway mucus which is then transported upwards to the pharynx by motile cilia. *Humidification* (to 100% saturation) is achieved by moist upper airway membranes. Failure of warming or humidification leads to ciliary failure and endothelial damage which can take weeks to recover.

Gas exchange begins at the level of the smaller respiratory bronchioles and is maximal at the alveolar-capillary membrane – the interface between pulmonary arterial blood and alveolar air.

(NB: The blood supply to the bronchioles remains unoxygenated. About one-third returns to the systemic venous system, but two-thirds returns to the systemic arterial circulation via the pulmonary veins, contributing to the 'physiological shunt', *below*).

## Ventilation

Minute ventilation is the volume of gas expired from the lungs each minute.

$$\text{Minute Ventilation (MV)} = \text{Tidal Volume (V}_T\text{)} \times \text{Respiratory Rate (RR)}$$

MV can therefore be altered by increasing or decreasing depth of the breathing (tidal volume) or RR. Of interest, not much ventilation is needed to deliver enough O<sub>2</sub> to the lungs: basal metabolic demands might only be ~ 250 mL/min (3.5mL/kg/min) for a 70kg person, and ambient air contains 21% oxygen – so only 1 L/min air is needed to supply this (or one big breath of 100% oxygen!). We breathe a lot more than this, though, to clear CO<sub>2</sub>. Thus, **oxygenation tells you little about ventilation**. In doing brainstem death tests, 1-2 L of O<sub>2</sub> irrigating the lungs will keep arterial O<sub>2</sub> saturation (SaO<sub>2</sub>) of 100%, while CO<sub>2</sub> rises by about 1 kPa every minute. Only when CO<sub>2</sub> levels get really high will SaO<sub>2</sub> start to fall – and this because there is 'less space' for O<sub>2</sub> in an alveolus full of CO<sub>2</sub>. This is enough to know, *but if you want a more detailed explanation, the simplified alveolar gas equation offers more detail:*

$$\text{PAO}_2 = \text{FiO}_2 (\text{P}_{\text{atm}} - \text{pH}_2\text{O}) - \text{PACO}_2/\text{R}$$

PAO<sub>2</sub> and PACO<sub>2</sub> are alveolar partial pressures of O<sub>2</sub> and CO<sub>2</sub> respectively, FiO<sub>2</sub> is the fractional concentration of inspired O<sub>2</sub>, pH<sub>2</sub>O is the saturated vapour pressure at body temperature (6.3 kPa or 47 mmHg), P<sub>atm</sub> is atmospheric pressure and R is the ratio of CO<sub>2</sub> production to O<sub>2</sub> consumption [usually about 0.8]. The arterial partial pressure of CO<sub>2</sub> (PaCO<sub>2</sub>) can be substituted for its alveolar pressure (PACO<sub>2</sub>) in this equation as it is easier to calculate. Thus, as ventilation falls, alveolar CO<sub>2</sub> concentration rises, and alveolar oxygen tension has to fall.

## Dead space

A portion of each breath ventilates a physiological dead space (V<sub>D</sub> = ~ 2mL/kg body weight), which doesn't take part in gas exchange. It has two components:

- **Anatomical:** the volume which never meets the alveolar membrane (mainly being contained in the conducting airways, or an endotracheal tube);
- **Alveolar:** the part of tidal volume which reaches areas of the lung which are not perfused – so gas exchange cannot happen;

The proportion of V<sub>T</sub> which reaches perfused alveoli = V<sub>T</sub> – V<sub>D</sub>, and is called the alveolar volume. The volume of gas reaching perfused alveoli each minute is *alveolar ventilation* = V<sub>A</sub> x RR, or:

$$\text{V}_A = \text{RR} \times (\text{V}_T - \text{V}_D)$$



$P_{aCO_2}$  depends on the balance between  $CO_2$  production ( $V_{CO_2}$ ) and alveolar ventilation: where  $k$  is a constant,

$$P_{aCO_2} = kV_{CO_2}/V_A$$

High arterial  $CO_2$  levels (hypercapnia) can thus result from reduced minute ventilation and/or increased anatomical dead space or an increase in non-perfused lung.

### Ventilation/perfusion matching

Deoxygenated blood passes from the great veins to the right ventricle, into the pulmonary arteries (PA), and then to the pulmonary capillaries. The distribution of blood flow (Q) and ventilation (V) is closely matched ('V:Q matching') throughout the lung, minimizing physiological dead-space, and maximising the efficiency of  $CO_2$  clearance and oxygenation. The optimal V:Q ratio is 1. Imagine if half the blood in the lungs went to un-ventilated alveoli (V:Q = 0.5). This blood would reach the left ventricle (and thus the arterial tree) just as deficient in oxygen (deoxygenated) as it was when it arrived from the veins. An area like this which is well perfused but not adequately ventilated is described as a *physiological shunt*. Alternatively, imagine one lung having no blood supply at all (V:Q >1): the volume of one lung is now just dead space – acting as a massive 'snorkle'!

Pulmonary vascular resistance is ~4/5<sup>th</sup> lower than that in the systemic circulation, meaning that PA pressure is also ~4/5<sup>th</sup> lower than arterial blood pressure. But resistance can change locally. If alveoli are poorly ventilated, alveolar  $O_2$  tension falls. In response, local blood vessels constrict ('Hypoxic Pulmonary Vasoconstriction' or HPV) and local blood flow falls. In this way, the worst ventilated areas are also the worst perfused, and V:Q matching is sustained.

In fact, V:Q matching varies in different parts of the lung, and is affected by posture. When upright, blood (being a fluid under the influence of gravity) is preferentially directed to the lung bases, where perfusion is thus greatest. But here the pleural pressure is higher, due to the dependant weight of the lungs, and alveolar ventilation poorest. V:Q ratio is thus low. The reverse is true at the apex. This is probably enough to know. But *a more detailed description (if you really want it) is as follows:*

In an upright position, arterial ( $P_a$ ) and venous ( $P_v$ ) pressures are highest in the lung bases, and pressures in the alveoli ( $P_{Alv}$ ) the same throughout the lung, allowing the lung to be divided into three zones:

#### Zone 1 (apex)

**In theory,  $P_{Alv} > P_a > P_v$ , and perfusion is minimal.** In reality  $P_{Alv}$  only exceeds  $P_a$  and  $P_v$  when pulmonary arterial pressure is reduced (hypovolaemia) or  $P_{Alv}$  is increased (high airway pressures on a ventilator, or high 'PEEP' – [pages 72-73](#)). In this zone, limited blood flow means that there is alveolar dead space.

#### Zone 2 (midzone)

**$P_a > P_{Alv} > P_v$ .** The post-capillary veins are often collapsed which increases resistance to flow.

#### Zone 3 (base)

**$P_a > P_v > P_{Alv}$ .** Both arteries and veins remain patent as their intravascular pressures each exceed extra-vascular/alveolar pressure, and pulmonary blood flow is continuous.

In the *supine* position (how many sick patients are standing?), the zones are redistributed according to the effects of gravity, with most areas of the lung becoming zone 3 and pulmonary blood flow becoming more evenly

distributed. Positive pressure ventilation increases alveolar pressure, increasing the size of zone 2.

### Practical Use of V:Q matching

One lung consolidated from a unilateral pneumonia, and SaO<sub>2</sub> very low? Rolling them onto the 'good' side (i.e., 'good side down') means that gravity improves the blood flow to the best lung – improving V/Q matching, and thus oxygenation. Sometimes, the patient is even rolled onto their chest ('prone ventilation') to help: but **never decide this yourself. It's a big deal, risky in the turning, and can make nursing very tricky. A consultant decision!** Inhaled nitric oxide does a similar thing: relaxing smooth muscle, well ventilated areas will benefit from greater ventilation, and by crossing the alveoli, nitric oxide relaxes vascular smooth muscle, increasing perfusion to these areas too. V:Q matching increases, and so too does oxygenation. Inhaled (nebulised) prostacyclin is sometimes used to do the same thing.

### A brief reminder of lung volume terminology

**V<sub>T</sub>**: Tidal volume – the volume of gas inspired / expired per breath.

**IRV**: Inspiratory reserve volume – the maximum volume of gas that can be inspired on top of normal tidal volume.

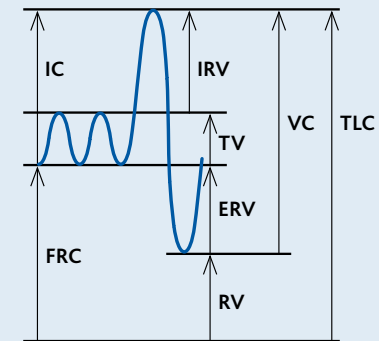

Fig 1

**ERV**: Expiratory reserve volume – the maximum volume that can be forcibly expired at the end of expiration during normal quiet breathing.

**RV**: Residual volume – the volume of gas left in the lung following a maximal forced expiration.

*Capacities within the lung are sums of the lung volumes:*

**FRC**: Functional residual capacity – the volume of gas in the lung at the end of normal quiet breathing:

$$\text{FRC} = \text{ERV} + \text{RV}$$

**VC**: Vital capacity – the total volume of gas that can be inspired following a maximal expiration:

$$\text{VC} = \text{ERV} + \text{TV} + \text{IRV}$$

**TLC**: Total lung capacity – the total volume of gas in the lung at the end of a maximal inspiration:

$$\text{TLC} = \text{IC} + \text{FRC}$$

**IC**: Maximum amount of air that can be inhaled after a normal tidal expiration:

$$\text{IC} = \text{TV} + \text{IRV}$$

NB: Closing Capacity (CC) is the volume at which airways collapse at the end of expiration. FRC needs to be  $>CC$  for the airways not to collapse at the end of an expiration.

## Control of breathing

The respiratory centre that regulates ventilation is located in the medulla. Its output coordinates the contraction of the intercostal muscles and the diaphragm. The respiratory centre receives inputs from the cerebral cortex, hence breathing is affected by our conscious state – fear, arousal, excitement etc. There is also input from central (medullary) and peripheral (carotid body, naso-pharynx, larynx and lung) chemoreceptors, so as to maintain  $PaCO_2$ ,  $PaO_2$  and pH within normal physiological ranges (and sensitive to changes in all three such parameters).

**Hypoxaemia** is mainly sensed by peripheral chemoreceptors located at the bifurcation of the common carotid artery. A  $PaO_2$  below 8 kPa drives ventilation ('Hypoxic Ventilatory Response' or HVR). HVR is higher when  $PaCO_2$  is also raised.

**Hypercarbia** is sensed mainly by central chemoreceptors (via increases in  $[H^+]$ ) and drives ventilation. The response to a rise in  $CO_2$  is maximal over the first few hours and gradually declines over the next 48 hours, and then further as renal compensation for arterial pH occurs. Hypoxic ventilatory drive can be important in patients with chronic lung disease who have a persistent hypercarbia.

## 2 Respiratory failure

Respiratory failure is a condition in which the respiratory system is unable to maintain adequate gas exchange to satisfy metabolic demands, i.e. oxygenation of and/or elimination of  $CO_2$ . It is conventionally defined by an arterial  $O_2$  tension ( $PaO_2$ ) of  $<8.0$  kPa (60 mmHg), an arterial  $CO_2$  tension ( $PaCO_2$ ) of  $>6.0$  kPa (45 mmHg) or both.

Respiratory failure is generally classified as:

- 1 **Acute hypoxaemic, or type I.** Low  $O_2$  with normal/low  $CO_2$ . Most commonly poor V:Q matching (areas of the lung become poorly ventilated but remain perfused) – e.g. pneumonia, pulmonary oedema or ARDS ([page 176](#)), or pulmonary embolism (which redistributes blood flow);
- 2 **Ventilatory, or type II.** Secondary to failure of the ventilatory pump (e.g. CNS depression, respiratory muscle weakness), characterised by hypoventilation with hypercapnia;
- 3 **Post-operative (type III respiratory failure)** is largely a version of type I failure, being secondary to atelectasis and reduction of the functional residual capacity;
- 4 **Type IV respiratory failure**, secondary to hypoperfusion or shock. Blood flow to the lung is inadequate for oxygenation or  $CO_2$  clearance.

## Hypoxaemic (type I) respiratory failure

Acute hypoxaemic (type I) respiratory failure derives from one or more of the following four pathophysiological mechanisms:

*The first* and most common mechanism is due to *ventilation/perfusion mismatching*, which is explained above. This occurs when alveolar units are poorly ventilated in relation to their perfusion (low Va/Q units). As the degree of Va/Q maldistribution increases, hypoxaemia worsens because a greater proportion of the cardiac output (CO) remains poorly oxygenated.

*The second* mechanism, *diffusion impairment*, results from increased thickness of the alveolar capillary membrane, short capillary transit time (e.g. very heavy exercise or hyperdynamic states, with blood crossing the alveolar capillaries too fast to pick up much oxygen), and a reduction in the pulmonary capillary blood volume. It very rarely occurs in clinical practice.

*The third* mechanism is (regional) *alveolar hypoventilation*, which 'fills alveoli with CO<sub>2</sub> and leaves less space for oxygen' (see above).

*The fourth* mechanism is *true shunt*, where deoxygenated mixed venous blood bypasses ventilated alveoli, results in 'venous admixture'. Some of this comes from bronchial blood draining into the pulmonary veins (see above). This can worsen hypoxaemia – but isn't really part of 'respiratory failure'. This is probably all you need to know, *but if you want to know more:*

*Cardiac output (Qt) comprises blood flow through the pulmonary capillaries (Qc) and that bypassing the lung (Qs). Thus, Qt=Qc+Qs. The oxygen content of the cardiac output will be Qt x CaO<sub>2</sub>, where CaO<sub>2</sub> is arterial oxygen content. This is made up of the oxygen content of the shunt blood (Qs x CvO<sub>2</sub>, where CvO<sub>2</sub> is venous oxygen content) and that of the capillary blood (Qc x CcO<sub>2</sub>, where CcO<sub>2</sub> is the pulmonary capillary oxygen content). With a bit of maths (try it!) you can work out that the shunt fraction (Qs/Qt), = (CcO<sub>2</sub>-CaO<sub>2</sub>)/(CcO<sub>2</sub>-CvO<sub>2</sub>), or Qs/Qt= (1-SaO<sub>2</sub>)/(1-SvO<sub>2</sub>). It is difficult in practice to distinguish between true shunt and Va/Q mismatch. However, there is a way of finding out! Va/Q maldistribution results in hypoxaemia because the distribution of alveolar oxygen tension is uneven. However, when breathing FiO<sub>2</sub>=1, the alveolar O<sub>2</sub> tension becomes uniform. Va/Q scatter has negligible effect on alveolar-arterial O<sub>2</sub> gradient at a FiO<sub>2</sub>=1, and therefore is possible to distinguish the two processes.*

Low mixed venous oxygen saturation (SvO<sub>2</sub>) may also contribute to arterial hypoxia. This represents the amount of oxygen left in the blood after passage through the tissues, and generally indicates the balance between oxygen delivery and consumption. Arterial oxygen content is discussed in  page 36. Normally, only 20-30% of the oxygen in arterial blood is extracted by the tissues (oxygen extraction ratio, O<sub>2</sub>ER), the rest returning in the venous circulation, whose saturation can be estimated from that in a sample from a central venous catheter (central venous O<sub>2</sub> saturation, ScvO<sub>2</sub>), or accurately in the pulmonary artery using a pulmonary artery catheter (mixed venous O<sub>2</sub> saturation, SvO<sub>2</sub>). SvO<sub>2</sub> values between 70-80% represent an optimal balance between global O<sub>2</sub> supply and demand. Lower values result if oxygen delivery falls (a fall in arterial oxygen

content or in cardiac output) or if metabolic demands (oxygen consumption,  $\text{VO}_2$ ) rises. Such a fall worsens the effect of shunt or low V/Q ratio on  $\text{PaO}_2$ . Increasing arterial oxygen content by blood transfusion (to achieve a haematocrit > 30%), and optimising cardiac output (with fluids and/or inotropes) can thus sometimes help arterial oxygen saturation! (👉 box 1, below for further details).

The Fick equation for  $\text{VO}_2$  helps to interpret the  $\text{SvO}_2$ :

$$\text{SvO}_2 = \text{SaO}_2 - (\text{VO}_2/\text{CO})$$

where CO is cardiac output, (litres/minute) and  $\text{VO}_2$  is body oxygen consumption/minute. This means that, for a given arterial saturation, an increase of the ratio  $\text{VO}_2/\text{CO}$  (increase in  $\text{VO}_2$  or a decrease in CO) will result in a decrease of  $\text{SvO}_2$ .

The relationship between  $\text{O}_2\text{ER}$  and  $\text{SvO}_2$  is apparent from the following equation:

$$\text{O}_2\text{ER} = \text{SaO}_2 - \text{SvO}_2/\text{SaO}_2$$

Therefore, global and regional  $\text{SvO}_2$  can represent  $\text{O}_2\text{ER}$ .

**Box 1** Relationship between cardiac oxygen consumption, oxygen extraction and mixed venous saturation

The hypoxia of type I respiratory failure is often associated with a decrease in arterial  $\text{PCO}_2$ , due to the increase in ventilation caused by the HVR (above).  $\text{PCO}_2$  can rise if respiratory muscle fatigue or CNS impairment ensue, and minute ventilation falls.

### Hypercapnic (Type II) respiratory failure

In normal conditions,  $\text{CO}_2$  production ( $\text{VCO}_2$ ) drives an increase in minute ventilation, meaning that arterial  $\text{PCO}_2$

( $\text{PaCO}_2$ ) is maintained within a very tight range (36-44 mmHg, 4.8-5.9 kPa) (respiratory control, 👉 page 20). However, if a patient's alveolar ventilation is reduced relative to  $\text{VCO}_2$ ,  $\text{PaCO}_2$  will rise. Put simply, this can result from fewer breaths and/or (especially) smaller breaths, when a greater proportion of each breath is just ventilating the airways and not the alveoli ( $\text{V}_D/\text{V}_T$  rises, 👉 page 28).

**There are three major causes of (ventilator pump) failure leading to hypercapnia:**

- 1 Central depression of respiratory drive** (e.g. brainstem lesions, opioids, Pickwickian syndrome);
- 2 Uncompensated increases in dead space.** These can be anatomical (e.g. equipment like endotracheal tube, Heat and Moisture Exchangers (HME) [👉 page 51]) or due to ventilation perfusion mismatch with high V/Q: here, much of the ventilation is into poorly perfused alveoli which, having limited  $\text{CO}_2$  delivery to them, act as a dead space;
- 3 Reduced respiratory muscle strength from neuromuscular diseases** (for instance, failed motor conduction to respiratory muscles as in spinal cord damage, or peripheral neuropathy such as Guillain-Barre Syndrome) or muscle wasting (e.g. malnutrition, cancer cachexia, or Intensive Care Acquired Weakness);
- 4 Respiratory muscle fatigue.**  $P_I$  is the mean tidal inspiratory pressure developed by the inspiratory muscles per breath, while  $P_{\text{max}}$  is the maximum inspiratory pressure possible – an index of ventilator neuromuscular competence. The work of breathing increases as overall ventilation (VE) rises, or as  $P_I$  rises due to increased elastic load (stiff lungs, pulmonary

oedema) or resistive load (e.g. airways obstruction such as asthma). Note that lying flat, with a big abdomen (fat, ascites, etc.) also hugely increases ventilatory workload as a result of diaphragm compromise.

Ventilatory work also rises if FRC rises. This most commonly results from airway obstruction, when longer is needed to exhale each breath fully. If this expiratory phase ( $t_E$ ) is insufficient, FRC rises with successive breaths (so called 'dynamic hyperinflation') and a positive pressure remains at the end-expiration (intrinsic PEEP, iPEEP). This increases ventilatory work, as does the fact that tidal breathing occurs on a flatter portion of the respiratory compliance curve: inspiratory muscles are forced to work on an inefficient part of their force/length relationship. In addition, the flattened diaphragm finds it hard to convert tension to pressure.

If ventilatory work is too high, the respiratory muscles will tire,  $CO_2$  clearance will fall, and arterial  $CO_2$  will rise.

Severe hypercarbia can cause hypoxaemia (the oxygen in the alveoli is 'diluted' by higher  $CO_2$  levels).

In the absence of underlying pulmonary disease, hypoxaemia accompanying hypoventilation is characterised by normal gradient between alveolar and arterial oxygen tension ( $P_{(A-a)}O_2$  gradient). In contrast, disorders in which any of the other three mechanisms are operative are characterised by widening of the alveolar/arterial gradient resulting in severe hypoxemia.

If  $f$  decreases in the context of unchanged total ventilation ( $V_E$ ),  $V_T$  must increase for  $V_E$  to remain unchanged. The ratio of ventilated dead space to total tidal volume ( $V_D/V_T$ ) thus falls thereby increasing  $V_A$  and decreasing  $PaCO_2$ .

### The relationship between $PaCO_2$ and alveolar ventilation ( $V_a$ ) is:

$$PaCO_2 = kVCO_2/V_A; PaCO_2 = kVCO_2/V_E - V_D$$

$$PaCO_2 = kVCO_2/V_T \cdot f \cdot (1 - V_D - V_T)$$

where  $k$  is a mathematical constant ('fudge factor')  $V_E$  is minute ventilation and  $V_D$  dead space ventilation,  $V_T$  is tidal volume and  $f$  respiratory frequency. Therefore, at constant  $VCO_2$  and  $V_D$ ,  $V_A$  depends on  $V_T$  or  $f$ . This means that hypercarbia can be caused by four possible conditions:

- 1 Unchanged total ventilation with decreased  $f$ ,
- 2 Unchanged total ventilation with increased  $f$ ,
- 3 Decreased total ventilation with decreased  $f$ , or
- 4 Decreased  $V_T$ .

If  $f$  increases in the context of unchanged total ventilation ( $V_E$ ),  $V_T$  must decrease:  $V_D/V_T$  ratio rises,  $V_A$  decreases and  $PaCO_2$  rises.

### Indices of oxygenation and ventilation

The most common indices you might hear talked about are:

*The alveolar to arterial ( $P_{(A-a)}O_2$ )  $O_2$  gradient* is the difference between alveolar  $PAO_2$  (calculated using the alveolar gas equation,  $PAO_2 = PIO_2 - (PaCO_2/R)$ ) and  $PaO_2$ .

The normal A-a gradient for a patient breathing room air is approximately  $2.5 + (0.21 \times \text{age in years})$ , but influenced by  $\text{FiO}_2$ .

**The respiratory index**, calculated by dividing  $P_{(A-a)O_2}$  gradient by  $\text{PaO}_2$ , is less affected by the  $\text{FiO}_2$ . It normally varies from 0.74-0.77 when  $\text{FiO}_2$  is 0.21 to 0.80-0.82 when on  $\text{FiO}_2$  of 1.

**The  $\text{PaO}_2/\text{FiO}_2$  ratio** is easy to calculate, and a good estimate of shunt fraction. A  $\text{PaO}_2/\text{FiO}_2$  ratio of  $<300$  mmHg (40 kPa) is a criterion used to define ARDS, according to the recent definition (Berlin definition of ARDS, 2012) (🔗 page 176). The lower the  $\text{PaO}_2/\text{FiO}_2$  ratio, the greater the shunt fraction, meaning that a greater proportion of the blood that travels through the lung parenchyma is not in contact with ventilated (and oxygenated) alveoli. For example a  $\text{PaO}_2/\text{FiO}_2$  ratio  $<300$ -201 mmHg (40-26.8 kPa) corresponds approximately to a shunt fraction of 20%, a  $\text{PaO}_2/\text{FiO}_2$  ratio 200-101 mmHg (26.6-13.5 kPa) corresponds approximately to a shunt fraction of 30%, and  $\text{PaO}_2/\text{FiO}_2$  ratio  $<100$  mmHg ( $<13$  kPa) corresponds to a shunt fraction of  $>40\%$ .

**Oxygenation index (OI)** takes mean airway pressure into account and is calculated as:

$$OI = (\text{FiO}_2 \times P_{aw} \times 100) / \text{PaO}_2$$

#### **Dead space ventilation**

Dead space is the portion of minute ventilation that does not participate in gas exchange. Its calculation is based on the difference between end-tidal  $\text{CO}_2$  ( $\text{PECO}_2$ ) and  $\text{PaCO}_2$ , using the Bohr equation;  $V_d/V_t = (\text{PaCO}_2 - \text{PECO}_2) / \text{PaCO}_2$ . In normal conditions  $V_d/V_t$  is 0.2 to 0.4.

## 3 Arterial blood gas analysis, oximetry and capnography

### Acid-base balance and buffering

The pH of a body fluid reflects hydrogen ion concentration ( $[\text{H}^+]$ ): a change in pH of 0.1 indicates a 10-fold change in  $[\text{H}^+]$ . Arterial pH is normally held within a narrow range by the action of buffers, including Hb and albumin. Phosphate ( $\text{H}_2\text{PO}_4^-/\text{H}_2\text{PO}_4^{2-}$ ) plays a minor role, with the carbonic (weak) acid/bicarbonate buffer pair being of far greater importance:



If buffering of metabolically-produced  $\text{H}^+$  is inadequate, pH will become abnormal ('metabolic acidosis'). The first response is a rise in minute ventilation (respiratory rate and tidal volume), 'blowing off'  $\text{CO}_2$  and thus 'dragging'  $\text{H}^+$  from the left hand side of the equation. If the patient is mandatorily ventilated, then you can do this for them. In the longer term (usually days), renal compensation occurs: respiratory acidosis (in COPD, for instance) may thus be compensated for by renal bicarbonate retention.

Base excess (BE, normally  $-2$  to  $+2$ ) is a calculated value, and represents the number of mEq of buffer which would need to be added to a litre of blood to restore pH to 7.4 at a temperature of  $37^\circ\text{C}$  and a  $\text{pCO}_2$  of 5.3 kPa. If the number is

negative (i.e. BE -8), then 8mEq would need to be added to restore pH – and the patient’s blood is thus ‘too acid’.

### Metabolic acidosis

This can result from:

#### *Too little bicarbonate*

- excess bicarbonate loss (for instance, renal loss, or loss from small bowel fistulae)
- reduced bicarbonate production (e.g. renal failure).

#### *Too much acid*

- excess acid production (for instance, lactic acid production by tumours or from regional or global ischaemia; ketoacids in diabetic ketoacidosis)
- reduced acid clearance (e.g. liver failure), or
- excess acid ingestion (most unusual!).

When faced with a metabolic acidosis, one should thus establish that:

- The blood sugar levels are and have been normal (to exclude diabetic ketoacidosis)
- The lactate is normal (to exclude a lactic acidosis)
- Renal function is normal (or, if not, is unlikely to be the sole cause of the acidosis)
- That the **chloride** is normal. Electrical neutrality must be maintained in the blood. If  $\text{Cl}^-$  rich solutions are given (such as Normal saline, and many colloids),  $\text{Cl}^-$  levels will rise. To maintain electrical neutrality, bicarbonate levels will fall, and with it pH.

Think of Normal (0.9%) Saline (NS). It contains 154mEq/L of  $\text{Na}^+$  – only 10% more than the  $\text{Na}^+$  concentration in your blood (140mEq/L). But the chloride concentration in NS is also 154mEq/L – 54% more than that in your blood (normally perhaps 100mEq/L). Three litres of NS thus raises your  $[\text{Na}^+]$  a little... and your  $[\text{Cl}^-]$  a lot... bicarbonate levels will fall... and pH will fall.

If all these are normal, check the *anion gap* – the difference between the concentration of routinely measured anions and cations,  $(\text{Na}^+ + \text{K}^+) - (\text{Cl}^- + \text{HCO}_3^-)$  – normally 8-12mEq/l. Thus, hyperchloraemic acidosis has a normal anion gap, and lactic – and keto-acidosis (being unmeasured) a raised anion gap. If none of these are the cause, then it is possible that some exogenous acid (aspirin, for instance) is in the blood ( *Table 1, below*).

Table 1

Increased anion gap	Normal anion gap
Ingestion of acid: salicylate poisoning, ethanol and methanol	Loss of bicarbonate via GI tract: diarrhoea/ileostomy
Lactic- or keto-acidosis	Renal problems: renal tubular acidosis
Inability to excrete acid: renal failure	

### Respiratory Acidosis

This occurs when  $\text{CO}_2$  clearance is inadequate for production. These situations are discussed in chapter 2 (*Respiratory failure*).



## Metabolic Alkalosis

Metabolic alkalosis is characterised by an increase in bicarbonate with or without a compensatory increase in CO<sub>2</sub>. It may occur from:

- Excess acid loss (such as in pyloric stenosis).
- Excess ingestion of alkali (rare).
- Renal bicarbonate retention (rare).
- As a consequence of hypokalaemia (causing a shift in H<sup>+</sup>).

## Respiratory alkalosis

Respiratory alkalosis occurs when an increase in ventilatory volume and/or rate causes a decrease in PaCO<sub>2</sub>. Such increased ventilation is often in response to pain, anxiety, hypoxia or fever – or when the patient on mechanical mandatory ventilation is ‘over-ventilated’.

## Arterial blood gas (ABG) analysis

An ABG sample may be drawn from an indwelling arterial catheter, or from an ‘arterial stab’. The commonest site used is the radial artery, although the brachial, femoral and *dorsalis pedis* can also be used. An ABG is the quickest way to accurately determine the true level of hypoxaemia. It will also tell you acid-base status, and help you determine the cause of derangement (giving you PaCO<sub>2</sub> and HCO<sub>3</sub><sup>-</sup>, lactate, chloride and glucose levels). Life-threatening changes in K<sup>+</sup> will also be detected, and Hb reported. Therefore, you will sometimes do an ABG when you’re not interested in ‘the gases’ (👉 *Table 2, opposite*).

Normal values	
pH	7.35-7.45
PaCO <sub>2</sub>	4.5-6 kPa (35-50 mmHg)
PaO <sub>2</sub>	11-14 kPa (83-105 mmHg)
Standard bicarbonate	22-28 mmol/l
Base deficit/excess	+/-2
Chloride	98-107 mmol/l

## Analysis

You should come up with your own plan of attack, but the following sequence generally works:

- 1 **Look at the K<sup>+</sup>, Hb and glucose.** You now won’t miss a life-threatening potassium/glucose levels, or profound anaemia.
- 2 **Look at the PaO<sub>2</sub> and arterial oxygen saturations** to determine how hypoxaemic the patient is. Note what the inspired oxygen concentration is! (i.e. PaO<sub>2</sub> of 12kPa, or 95% arterial oxygen saturations breathing 80% oxygen is NOT good! As a ‘rule of thumb’ the expected PaO<sub>2</sub> – in the absence of oxygenation defects – should be about 10 kPa less than the inspired oxygen partial pressure i.e. 40% FiO<sub>2</sub> should result in PaO<sub>2</sub> of 30 kPa)
- 3 **Look at the pH:** acidosis (<7.35) or alkalosis (>7.45)?

- 4 *Is the PaCO<sub>2</sub> abnormal?* If so, has it changed in a direction which accounts for the altered pH?
- 5 *Is the HCO<sub>3</sub><sup>-</sup> abnormal?* If yes, is the change in the same direction as the pH?

In the 'not mechanically ventilated' patient:

- An alkalosis with a low bicarbonate and a low PaCO<sub>2</sub> is likely to reflect a primary respiratory alkalosis with incomplete metabolic compensation.
- An acidosis with high bicarbonate and high PaCO<sub>2</sub> a primary respiratory acidosis with incomplete metabolic compensation.
- An alkalosis with high bicarbonate and a high PaCO<sub>2</sub> is likely to reflect a primary metabolic alkalosis with incomplete respiratory compensation.
- An acidosis with low bicarbonate and high PCO<sub>2</sub> a primary metabolic acidosis with incomplete respiratory compensation.

Normal pH with raised PaCO<sub>2</sub> and high bicarbonate may reflect:

- a primary metabolic alkalosis with complete respiratory compensation,
- or a primary respiratory acidosis with complete metabolic compensation.

The problem comes with mechanical ventilatory support, which alters PaCO<sub>2</sub> levels. One then has to

apply clinical acumen: if, for instance, normalising the PaCO<sub>2</sub> causes a marked alkalosis, and the bicarbonate was high, a metabolically-compensated respiratory acidosis or a respiratory-compensated metabolic alkalosis, were present. Your call as to which!

## 6 *Measure the anion gap.*

### Carbon monoxide poisoning

Carbon monoxide often comes from faulty boilers, smoke inhalation, or suicide attempts from breathing exhaust fumes from cars without catalytic converters. It causes hypoxia because its affinity for Hb is 240 times greater than that of O<sub>2</sub>.

The pulse oximeter, however, doesn't know the difference between oxyhaemoglobin and carboxyhaemoglobin (COHb). Therefore a grossly hypoxic patient may appear to have 'normal' oxygen saturations. In addition, the presence of carbon monoxide reduces the amount of O<sub>2</sub> released from the blood, as it shifts the O<sub>2</sub> dissociation curve to the left.

Fortunately most ABG analysers will check for COHb levels – and these are usually <1.5% non-smokers, and <9% for smokers. It is worth remembering that the half-life of COHb is 5-6 hours, and therefore prompt analysis is indicated if suspected.

### Unexpected results

ABG analysers use small amounts of blood and perform a relatively broad range of tests. Erroneous results may be obtained from time-to-time. An air-bubble caught in the syringe may go unnoticed thus raising the  $PO_2$ , and similarly Hb or potassium levels may be significantly deranged from previous readings. These uncertainties are usually best dealt with straight away by repeating the measurement with a fresh sample – something easily done with an arterial line in situ. If concern persists, repeat analysis using a different machine if possible.

### Arterial oxygen saturation and content

Hypoxaemia can be detected by ABG analysis. Alternatively, pulse oximetry is often used to monitor oxygen saturation ( $SaO_2$  – the percentage saturation of Hb by oxygen).

Plotting  $SaO_2$  against  $O_2$  tension (in kPa) yields the oxy-haemoglobin dissociation curve – the percentage saturation of Hb with  $O_2$  at different partial pressures of  $O_2$  dissolved in the plasma. The curve can shift in response to a variety of factors. A ‘left’ shift means that, for the same  $PaO_2$ ,  $SaO_2$  is higher; i.e., Hb picks up and holds  $O_2$  more readily, and is less willing to release it. A ‘right’ shift means that saturation is lower at any given partial pressure of  $O_2$ : Hb picks up and holds  $O_2$  less readily, and is more willing to release it (👉 Fig 2, opposite).

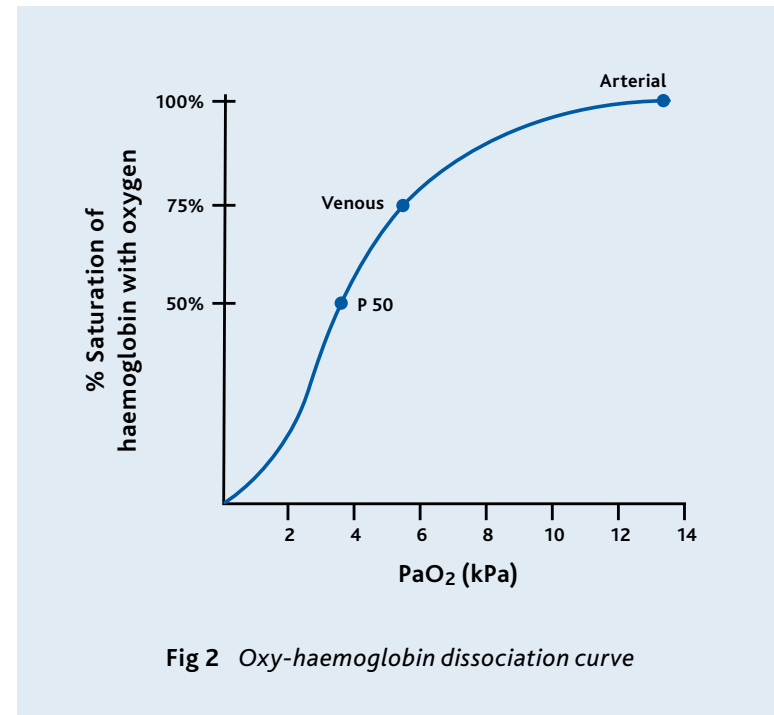

Fig 2 Oxy-haemoglobin dissociation curve

1g Hb can carry 1.34mL of  $O_2$ . The arterial  $O_2$  content ( $CaO_2$ ) of 1 litre of blood – being largely carried by Hb (measured in g/L), and not in solution – is thus:

$$\text{O}_2 \text{ content} = S_aO_2 \times 1.34 \times Hb$$

When Hb is 150 g/L and blood 100% saturated,  $CaO_2$  is approximately 200 mL  $O_2$  per litre blood ( $100 \times 1.34 \times 150$ ).

**O<sub>2</sub> delivery** to tissues per minute will thus be oxygen content per litre x cardiac output (litres/minute). CO can be 'indexed' (CI) to body surface area, and is normally 2.5-3.5 L/min/m<sup>2</sup>

Oxygen delivery index = DO<sub>2</sub>I = CI x CaO<sub>2</sub>

Presuming CI = 3 l/min/m<sup>2</sup> and Hb 140g/l, and SaO<sub>2</sub> 98%, then

DO<sub>2</sub>I = 3 x (1.34 x Hb x SaO<sub>2</sub>)

DO<sub>2</sub>I = 3 x (1.34 x 140 x 0.98)

DO<sub>2</sub>I = 550 ml/min/m<sup>2</sup>

### Top tips on O<sub>2</sub> saturation

- 1 Oxygenation is a very poor measure of *ventilation*. Monitoring SaO<sub>2</sub> in Guillain-Barre, or severe asthma, or spinal cord injury thus tells you little about how badly they are ventilating. By the time the SaO<sub>2</sub> falls, the patient is likely to rapidly decompensate.
- 2 Learn a few key points on the O<sub>2</sub> dissociation curve: 99% SaO<sub>2</sub> is upwards of 11 kPa. Below 8 kPa, SaO<sub>2</sub> starts to fall fast (from about 90%) for a small change in PaO<sub>2</sub>. 80% SaO<sub>2</sub> is approximately 6 kPa.
- 3 Always think of SaO<sub>2</sub> in the context of the inspired fractional O<sub>2</sub> concentration, or FiO<sub>2</sub>

(air is 21% O<sub>2</sub>, so FiO<sub>2</sub> is 0.21). As a good rule of thumb, PaO<sub>2</sub> = FiO<sub>2</sub> (%) minus 10. You breathe air, so you'd expect your PaO<sub>2</sub> to be about 11 kPa. So if someone is on 60% FiO<sub>2</sub> by mask, you'd expect PaO<sub>2</sub> to be ~50 kPa. If the SaO<sub>2</sub> is 94%, then PaO<sub>2</sub> is probably only ~9 kPa (when it should be ~50 kPa). Something is terribly wrong with the lungs, and the patient much more seriously ill than they might look!

## Capnography

Capnometry (performed by a *capnograph*) measures CO<sub>2</sub> in exhaled gas (most commonly by infrared absorption). Two sorts of capnograph exist:

- a **Sidestream systems** (the commonest) continually aspirate gas from the ventilatory circuit through a capillary tube. The CO<sub>2</sub> sensor and analyser are located in the main unit away from the airway.
 

*Advantages:* it can be used on awake patients, and with O<sub>2</sub> delivery through nasal prongs.
- b In **mainstream systems** (much bulkier), the CO<sub>2</sub> sensor lies between the breathing circuit and the endotracheal tube.
 

*Advantages:* no need for gas sampling, and no delay in recording.

The measured CO<sub>2</sub> concentration is usually plotted against time, the resulting capnogram exhibiting three distinct phases:

- **Phase I** occurs at the beginning of expiration when the anatomic dead space (where no gas exchanges between inspired gases and blood) empties.
- **Phase II** is the initial rise in CO<sub>2</sub> which results from the mixing of alveolar gas with dead space gas.
- **Phase III** is almost always a slow-rising plateau, and ends with **end-tidal CO<sub>2</sub> (ETCO<sub>2</sub>)**. This is normally 35-38 mmHg (4.5-5 kPa).

After phase III is completed, the capnogram descends quickly to baseline (phase 0). This represents the inspiratory phase where the fresh CO<sub>2</sub> free gases are inhaled.

( Fig 3, opposite)

### Clinical applications

Capnography reflects the production (metabolism), transportation (circulation) and removal of CO<sub>2</sub>. The trace will thus be altered by changes in:

- Cellular metabolism**  
Levels may thus rise with increases in temperature (e.g. malignant hyperthermia) or muscle activity (e.g. shivering, convulsions), or increased buffering of acid (ischaemia-reperfusion, administration of bicarbonate);
- Transportation of CO<sub>2</sub>**  
End-tidal CO<sub>2</sub> will decrease if CO decreases with constant ventilation (e.g. pulmonary [clot or air] embolism or sudden cardiac impairment);

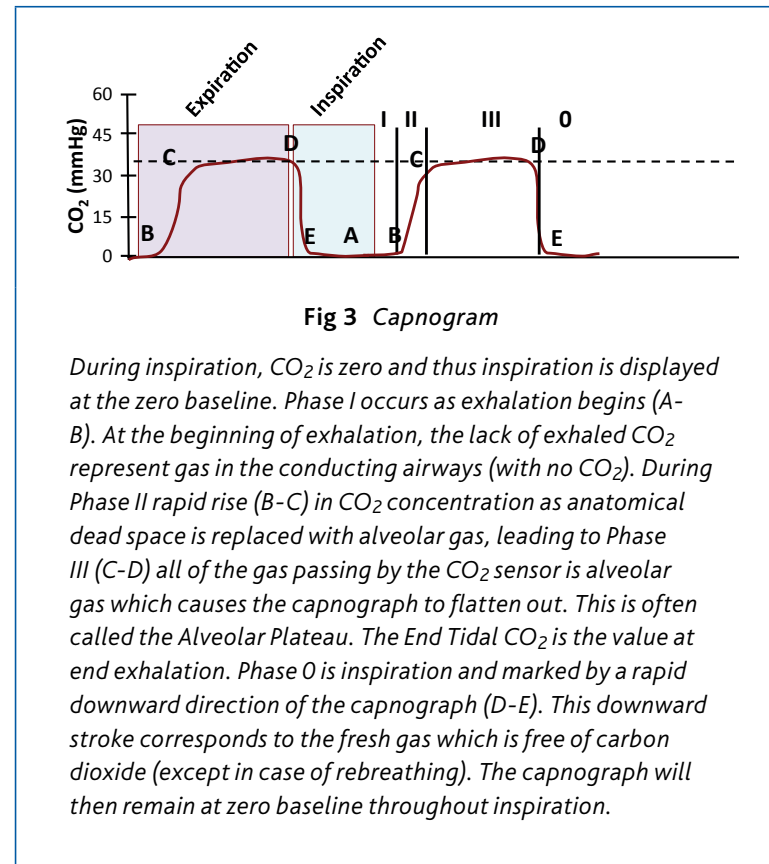

### c Ventilation

The trace can confirm endotracheal placement, and can be used as a surrogate for ABG analysis. Sudden decreases in the ETCO<sub>2</sub> may point toward total occlusion or accidental extubation of the endotracheal tube.

Capnography is most often used to ensure correct placement of the endotracheal tube (phasic CO<sub>2</sub> is not seen in oesophageal intubation). Measurements can also act as

a surrogate for PaCO<sub>2</sub>. When pulmonary gas exchange is normal, the end tidal CO<sub>2</sub> is only 2 to 3 mmHg (0.2 – 0.4 kPa) lower than the arterial PCO<sub>2</sub>. However, when gas exchange in the lungs is impaired, ETCO<sub>2</sub> decreases relative to PaCO<sub>2</sub> ( Fig 3, page 41).

#### Causes of raised (PaCO<sub>2</sub> – ETCO<sub>2</sub>) gradient:

- **Increased anatomic dead space:**
  - Open ventilatory circuit
  - Shallow breathing
- **Increased physiological dead space:**
  - Obstructive lung disease
- **Low cardiac output states**

In some circumstances the ETCO<sub>2</sub> can be higher than arterial CO<sub>2</sub>. This is possible when CO<sub>2</sub> production is high and there is low inspired volume or high CO. But this is really very uncommon.

When the gas exchange is abnormal and PaCO<sub>2</sub> is higher than ETCO<sub>2</sub>, it is still possible to monitor changes in ETCO<sub>2</sub> as a measure of changes in PaCO<sub>2</sub>. However it is important to establish ETCO<sub>2</sub>-PaCO<sub>2</sub> gradient which should be rechecked after each change in ventilator setting, as this can affect the gradient.

In cases of increased intracranial pressure, capnography is used to adjust ventilation in order to maintain the desired

ETCO<sub>2</sub>. In this setting, the ETCO<sub>2</sub>-PaCO<sub>2</sub> gradient should be closely monitored to maintain the ETCO<sub>2</sub> at a level to which delivers target PaCO<sub>2</sub>.

## 4 Supplemental oxygen therapy

When O<sub>2</sub> delivery falls below demands, supplemental O<sub>2</sub> should be delivered so as to maintain O<sub>2</sub> delivery at a level commensurate with survival and, ideally, with unimpaired organ function. This may require intervention to sustain Hb and CO (🔗 [page 36](#)), as well as the use of techniques to maintain arterial oxygen saturation. The simplest of these is the administration of supplemental oxygen.

### Supplemental oxygen therapy

O<sub>2</sub> administration is a simple **life-saving** intervention, although targeting a PaO<sub>2</sub> greater than needed does not confer additional benefits and high PaO<sub>2</sub> can be associated with worse outcome in certain conditions (e.g., after cardiac-arrest or myocardial infarction). On the other hand, one only has to consider the familiar sigmoid shape of the oxygen dissociation curve (🔗 [page 37](#)) to see that a failure to administer adequate O<sub>2</sub> may have disastrous consequences – the hypoxaemic patient balances precariously at the top of the sigmoid precipice, and it may only take a small reduction in PaO<sub>2</sub> to dramatically decrease SaO<sub>2</sub> and tissue O<sub>2</sub> delivery (🔗 [page 37](#)).

O<sub>2</sub> requirements can be assessed by considering O<sub>2</sub> delivery at the bedside: the SaO<sub>2</sub>, PaO<sub>2</sub> on arterial gas sampling, CO, and Hb. This should be balanced against how much work is going into delivering it (respiratory rate,

work of breathing), and whether it is sufficient (rising lactate suggests anaerobic metabolism: confusion and oliguria may suggest hypoxic organ dysfunction).

The target of O<sub>2</sub> therapy should be to give enough O<sub>2</sub> to return the PaO<sub>2</sub> to the level required *by that particular patient*. In practice, this usually means aiming for SaO<sub>2</sub> 94-98%. **In general, however, high flow O<sub>2</sub>** is indicated in shock, sepsis, major trauma, anaphylaxis, major pulmonary haemorrhage and carbon monoxide poisoning. NB hyperoxia may worsen outcome after cardiac arrest and should be avoided. In patients with chronic hypercapnia, **lower FiO<sub>2</sub> may be needed with target SaO<sub>2</sub> of 88-92%**. In these patients, the effects of high FiO<sub>2</sub> in determining hypercapnia are multiple:

- 1 Reduction in hypoxic ventilatory drive (some with COPD, cystic fibrosis, neuromuscular / chest wall disorders, obesity hypoventilation syndrome / morbid obesity: 🔗 [page 25](#)).
- 2 Reduction in hypoxic pulmonary vasoconstriction and increase in dead space ventilation.
- 3 Haldane effect: this is the displacement of CO<sub>2</sub> bound to the deoxygenated Hb, which is released in the plasma and accumulates as a result of chronic hypoxaemia.

A look at the initial ABG may be helpful in guiding you: if PaCO<sub>2</sub> is raised, but pH less deranged than you might expect (with a high blood bicarbonate), then chronic hypoventilation is likely (🔗 [page 24](#)). Here, and if you are confident that hypoxaemia isn't life-threatening, FiO<sub>2</sub> 28%

may be initiated, seeking SaO<sub>2</sub> targets of 88-92%. *Regular monitoring of ABGs is essential in this group of patients, because persistent acidosis and hypercapnia may require non-invasive ventilatory support or possibly intubation.*

Whilst students are often warned about the patient dependent upon hypoxic ventilatory drive (👉 page 25) who dies when supplemental O<sub>2</sub> is given, this is a rarity: in the severely hypoxaemic patient, one should err on the side of giving higher concentrations of O<sub>2</sub> if hypoxia seems grave, and then reducing it according to clinical response and ABG analysis. If there is only a mild degree of hypoxaemia (or if the hypoxaemia seems oddly well tolerated, suggesting that it may well be chronic), it may be more suitable to deliver low dose O<sub>2</sub> via nasal cannulae. *Note: if a patient is celebrating well, then the gases you see are likely 'closer to their normal' and needn't precipitate panicked responses!*

Non-invasive O<sub>2</sub> supplementation can be provided via nasal cannulae or face masks. A variety of O<sub>2</sub>-delivery devices exist, and it is helpful to know their relative pros and cons. However, the FiO<sub>2</sub> actually inhaled depends not only on the magnitude of flow of O<sub>2</sub> into the airway but on the respiratory rate, tidal volume and hence minute ventilation, i.e. giving 2 L/min to a normal patient breathing at rest (RR =12/min x TV = 500ml = Minute Ventilation 6 L/min) will increase their inspired oxygen fraction far more than will the same 2 L/min given to a tachypnoeic patient (e.g. RR 36). This is not just a simple issue of 'concentration'. High respiratory rates often mean

high inspiratory flow rates (i.e. gas moves fast on breathing in). Let's suppose that the peak inspiratory flow rate is 60 L/min. If O<sub>2</sub> is being delivered at 15 L/min (without some reservoir), then ordinary room air will be entrained during inspiration. The TRUE FiO<sub>2</sub> will thus be a lot lower than you imagined!

### Classification of O<sub>2</sub> delivery systems

- Variable performance systems  
(*Nasal cannulae, Hudson face masks*)
- Fixed performance systems  
(*Venturi-type masks*)
- High Flow systems
- Others

**Nasal cannulae** (like simple face masks) use the dead space of the naso-pharynx (or the device themselves) as an O<sub>2</sub> reservoir. Entrained air mixes with the air in the reservoir and the inspired gas is enriched with O<sub>2</sub>. For most patients, and as a general rule of thumb, each additional 1 L/min of O<sub>2</sub> flow via nasal cannulae increases FiO<sub>2</sub> by ~ 4%. The maximum amount of O<sub>2</sub> that can be administered via nasal cannulae is 6 L/min i.e. approximately 45% O<sub>2</sub>. Advantages include comfort and easy retention (not removed to speak, eat or drink). However, it is hard to accurately gauge FiO<sub>2</sub>. Nasal congestion impairs use, and nasal drying and irritation can occur.

**Simple face masks** (e.g. Hudson masks) deliver O<sub>2</sub> concentrations between 40% and 60%. The FiO<sub>2</sub> supplied will be inconsistent, depending on the flow rate and the



patient's breathing pattern (*see above*), but can be changed using O<sub>2</sub> flow rates of 5-10 L/min. Flow rates less than 5 L/min can cause exhaled CO<sub>2</sub> to build up within the mask (which is thus a sort of dead space, [page 25](#)) and thus to rebreathing. For these reasons, and the consideration made previously, such masks are often avoided in those with Type 2 respiratory failure.

**High concentration reservoir masks** deliver O<sub>2</sub> at concentrations of 60-90% and are used with a flow rate of 10-15 L/min. A bag acts as a reservoir of 100% O<sub>2</sub> from which to draw (thus overcoming the 'entrainment' problem outlined above). However, once again, the inspired concentration is not accurately measured and will depend on the pattern of breathing. These masks are used in the emergency or trauma patient where high flow O<sub>2</sub> is required and where CO<sub>2</sub> retention is unlikely ([Fig 4, below](#)).



Fig 4 High concentration reservoir mask (non-rebreathing)

**Venturi masks** provided an estimate of FiO<sub>2</sub> regardless of the flow rate (as long as it is above the minimum stated on the side of the valve) – although the EFFECTIVE FiO<sub>2</sub> may still be influenced by the patient's respiratory rate and pattern, particularly at higher FiO<sub>2</sub>. Slits found on the side of an attachment allow air to be entrained ([Fig 5, below](#)). Their size (and degree of entrainment) varies, as does the diameter of the O<sub>2</sub> entry point. The amount of entrained air is directly affected by the flow of O<sub>2</sub> into it, with different masks permitting selected flow rates of O<sub>2</sub> in spite of different amounts of gas being drawn in. There are a variety of colour – coded valves – 24% (Blue), 28% (White), 35% (Yellow), 40% (Red), 60% (Green) – and they are particularly useful when there is a need to control the amount of O<sub>2</sub> being delivered e.g. in COPD ([Fig 6, page 50](#)).

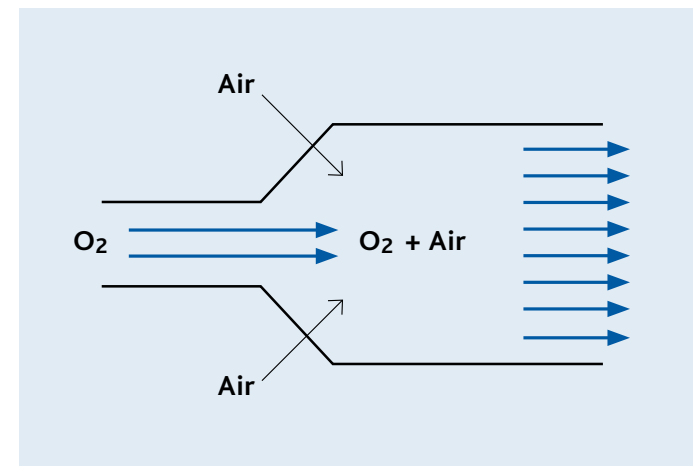

Fig 5 The Venturi Principle



**Fig 6** *Venturi mask with various valves*

## 5 Humidification

When a patient breathes through the nose, the inspired air is warmed to body temperature and becomes saturated with water vapour before entering the trachea. Medical gases have very low moisture content and, delivered via endotracheal tube or tracheostomy, cool and dry the lower airway. Mucus becomes thicker ('plugging' airways). The airway epithelium becomes desiccated, causing ciliary mucus transport to fail, and thence epithelial denudation. The risk of atelectasis, lobar collapse and infection then rises.

To avoid such consequences, inspired gases must be warmed and humidified. Active devices, such as heated humidifiers, add warm water vapour to a flow of gas independent of the patient. Passive devices, such as heat and moisture exchangers (HME), retain some of the heat and moisture which would otherwise be expired, to warm incoming gas.

Standards for humidifiers used with intubated patients specify that they must have a moisture output of at least  $33 \text{ gm}^{-3}$ , or an absolute humidity of 75%. This humidity is equivalent to that measured in the subglottic space during normal nasal breathing. Few HMEs have a moisture output at this level. However, HMEs are cheaper and easier to use.

### Passive devices

*Heat and moisture exchangers* are most commonly used, and each is a disposable 'single patient' device. Some designs can also filter out bacteria, viruses and particles in

either direction of gas flow, being called Heat and Moisture Exchanging Filters (HMEF). Positioned at the ventilator circuit 'Y connector', one port connects to the inspiratory limb and the other to the 'ETT' side of the ventilator circuit. Inside this unit is material impregnated with a hygroscopic substance. When warm moist expired gases pass through this element, water condenses – the latent heat release of which also warms it. During inspiration, cool dry air passes through the element – and is warmed and humidified – the element thus acting as an 'artificial nose'. Optimal function is only reached after 5-20 minutes, with units usually changed every 24 hours (although function may perhaps last 48 or even 96 hours).

#### HMEs may be best avoided when:

- Tidal volumes are small (when the HME's additional dead space can lead to increases in PaCO<sub>2</sub>).
- Secretions are thick, copious, or bloody, when they may be deposited on the moisture exchanging element, increasing the resistance to breathing, affecting the ability to wean from the ventilator and perhaps altering 'trigger sensitivity' ([👉 chapter 12](#)). Secretion deposition can also increase the risk of infection with organisms such as pseudomonas.
- When ventilatory volumes are very high (when they become inefficient).
- When core body temperature is <32°C (when they fail to work effectively).
- When expired volume is <70 % of delivered tidal volume (bronchopleural fistula).

### Active devices

The simplest method of humidifying the inspired gases is through *the instillation of water directly into the trachea* – by squirting 5-10 mls 0.9% saline (for instance) down the ETT each hour, or by 'drip-instilling' a set volume each hour. This is sometimes done when secretions are very thick and can help greatly in removing the rubbery bronchial casts of asthma.

*Heated humidifiers* (e.g. Fisher-Paykel systems) have two separate electrically-powered active heating systems. Firstly, a water chamber sits on a heater plate. Gas passes through this chamber, and then over a heater wire in the centre of the hose leading to the patient. Two sensor monitors gas temperature at the patient connection port and humidification chamber outlet respectively, and control heater wire temperature.

The temperature of the gas required at the patient-end of the delivery tube can thus be varied, as can relative humidity: if the temperature of the gas to be delivered to the patient connection port is to set to be higher than at the humidifier end of the delivery tube, the gas is warmed as it passes through the delivery tube. Condensation is therefore reduced, but the relative humidity of the gas also decreases. Alternatively, if the gas is allowed to cool as it passes through the delivery tube, it will be fully saturated with water vapour.

A water trap collects condensation in the expiratory limb. The humidifier and the water trap should be positioned below the level of the tracheal tube to prevent flooding of the airway by condensed water.

The **heated element humidifier** drips water onto an electric element heated to 100°C, the high temperature ensuring sterility. A water trap collects excess water. The amount of the water vapour delivered from these humidifiers must be controlled according to the minute volume and humidity required.

**Nebulisers** may be gas-driven or ultrasonic ( page 148). In both devices, droplets are produced; ideally with a diameter of about 1 µm. Droplets evaporate in the gas delivered to the patient so that the gas is fully saturated with the water vapour. As heat is required for the evaporation, the temperature of the gas falls. A heater can maintain the desired temperature of the gas. However, with these devices, it is relatively easy to add excessive moisture to the delivered gas, as some of the droplets do not evaporate, leading to the risk of excessive loading of the lungs with water.

## 6 Assessing the need for ventilatory support

**There are three main indications for mechanical ventilation:**

- 1 To support oxygenation (by improving delivery and/or reducing consumption through work of breathing).
- 2 To support CO<sub>2</sub> clearance, and
- 3 Reduce the work of breathing – assisting or 'resting' the respiratory muscles.

In addition, mechanical ventilation is sometimes needed as part of a package of care in managing the patient who is combative or restless (e.g. the agitated combative patient with multiple trauma).

### Assisting with oxygenation

This requires assessing the balance of O<sub>2</sub> delivery and O<sub>2</sub> consumption (*see section on Respiratory Failure*,  page 36).

O<sub>2</sub> *delivery* can be calculated as

**Cardiac output (in litres/min) x S<sub>a</sub>O<sub>2</sub> x 1.34 x Hb**

( page 38). You can usually determine Hb and S<sub>a</sub>O<sub>2</sub> easily enough, and can estimate cardiac output from the heart rate

and a feel for the pulse volume (high, normal or low). That allows for a rough-and-ready bedside guesstimate of oxygen delivery.

*O<sub>2</sub> consumption* can be estimated clinically by assessing the presence of muscle activity (shivering, restlessness, fits), fever, and work of breathing (nasal flaring, paradoxical chest wall movement, big swing on the CVP trace) – all associated with raised O<sub>2</sub> demands.

Useful, although indirect indices of whether O<sub>2</sub> delivery is meeting O<sub>2</sub> demand are a raised arterial lactate (suggesting the presence of anaerobic metabolism) or a low oxygen saturation of Hb taken from the superior vena cava (ScvO<sub>2</sub> [pages 22-23](#)) – but not from a femoral central catheter. If ScvO<sub>2</sub> is low, it is very likely that there is a deficit in O<sub>2</sub> delivery relative to demand. However, it needs to be kept in mind that normal or high ScvO<sub>2</sub> do not exclude O<sub>2</sub> supply deficiency in certain clinical conditions such as sepsis when peripheral tissues are unable to extract O<sub>2</sub> from capillary blood.

**When an imbalance of  
O<sub>2</sub> demand and O<sub>2</sub> delivery exists, one can  
address BOTH sides of the equation:**

*Reducing Demand* can be achieved by cooling the febrile patient (physically or with paracetamol), reducing work of breathing with nebulisers (if asthmatic), or offering adequate sedation, neuromuscular paralysis or analgesia.

*Increasing Delivery* can be achieved by the use of supplemental oxygenation, other techniques to improve oxygenation (e.g., the use of PEEP ([page 54](#)), recruitment manoeuvres ([page 133](#)), or altered I:E ratios, raising Hb concentration, and increasing the CO (with the use of fluids and/or inotropes where indicated).

Mechanical ventilation can help address both sides of the equation. Muscle activity in the sedated patient is lower, and reduced further if the patient is pharmacologically paralysed. Work of breathing – a potent consumer of oxygen – is also limited. Thus, at rest, about 4ml in every 100ml of oxygen your body is using is consumed by the work of breathing. In a patient after thoracic surgery, this might double, whilst in severe COPD or pulmonary oedema, work increases even more.

### Assisting with CO<sub>2</sub> clearance

Sometimes, work of breathing exceeds capacity, and minute ventilation becomes inadequate to clear CO<sub>2</sub> ([page 14](#)). In such circumstances, the addition of ventilator support can aid in maximising alveolar minute ventilation. Remember, of course, to see whether the raised CO<sub>2</sub> is chronic and compensated for: a CO<sub>2</sub> of 14kPa probably doesn't need emergency support, if the pH is near-normal due to chronic metabolic compensation ([page 29](#)). Do also put all ABGs in their clinical context: a fit 17 year old sprinter with acute asthma should be able to maintain minute ventilation – and a rising CO<sub>2</sub> this suggests respiratory muscle fatigue which might prove rapidly fatal.

### Assisting with the agitated patient

Sometimes, mechanical ventilation is instigated when 'the lungs are fine'. Thus, an agitated patient who won't lie still for a CT head scan may need to be paralysed, intubated and ventilated. The same holds true, for instance, of the bomb victim with severe injuries, who is trying to launch themselves to the floor – preventing central line insertion and appropriate assessment and management.

## 7 Continuous positive airway pressure (CPAP)

CPAP consists in the application of constant positive airway pressure throughout the respiratory cycle in spontaneously breathing patients. Alveoli are like party balloons: when small, they need a lot of work to blow them up, and (especially when small) have a tendency to collapse down and empty. Were this to happen, alveoli would collapse at the end of every breath, needing a lot of work to re-expand them with each breath in. In addition, some alveoli wouldn't reinflate with smaller breaths, leading to V:Q mismatch, and hypoxaemia ( pages 16, 22).

Two processes help overcome these problems:

- 1 Alveoli produce surfactant – a detergent which lowers the surface tension of the wall. This effect increases as alveolar size falls. However, lung inflammation damages alveoli, causes proteinaceous fluid to leak into them, and preventing them making surfactant.
- 2 Partial closure of the glottis (and possibly vocal cord apposition) at the end of expiration 'traps' some air in the lungs, and keeps the pressure in the airways about 3-5 cm H<sub>2</sub>O greater than atmospheric pressure. This positive pressure within the alveoli at the end of expiration is known as 'Positive End-Expiratory Pressure' or PEEP, and helps hold them open.

Endotracheal intubation holds the glottis and cords open, so PEEP is lost and alveoli tend to collapse unless we apply this PEEP artificially ([📖 page 59](#)).

When alveoli collapse, local ventilation falls while local perfusion may be sustained – the resulting V:Q mismatch causing hypoxaemia ([📖 page 22](#)). This may be partly overcome by augmenting airway pressure with a continuous ‘extra pressure’ throughout the respiratory cycle. Continuous positive airway pressure (CPAP) increases FRC, reduces V:Q mismatch, and improves oxygenation. Work of breathing may be reduced by maintaining a mouth-to-alveolar gradient, and by helping keep alveoli open. In addition CPAP has cardiovascular effects reducing cardiac preload and reduce the left ventricular afterload by decreasing the left ventricular transmural pressure. These effects are advantageous in patients with cardiogenic pulmonary oedema.

**Measures of ‘success’ in using CPAP are thus:**

- a Improvement in respiratory pattern (due to improved oxygenation and reduced work of breathing relieving dyspnoea).
- b Improvement in oxygenation.

**To work, CPAP needs:**

- 1 A sealed system. Thus, masks are tight-fitting and leak-free.  
Facemasks and nasal masks are both used. Patients often prefer nasal masks, but must keep their mouths closed, as positive airway pressure is lost every

time the mouth is open. In most patients with acute respiratory failure, full face masks are a more appropriate choice. Masks are usually made from non-irritant material such as silicon rubber, and have minimal dead space and soft (usually inflatable) cuffs to provide a seal with the skin. All masks exert pressure on the nasal bridge, and can cause ulceration. A ‘full head helmet’ system overcomes this problem.

- 2 A continuous flow of gas at a flow rate which exceeds peak inspiratory flow rate at all times. Otherwise, the pressure in the system will fall on inspiration.
- 3 A system for humidifying the delivered gas, if used for prolonged periods.
- 4 A valve at the outlet of the system, which maintains a pre-determined pressure (often 5, 7.5 or 10 cmH<sub>2</sub>O). However CPAP can be provided using a variety of standard ICU ventilators using the non-invasive modality ([📖 Fig 7, below](#)).

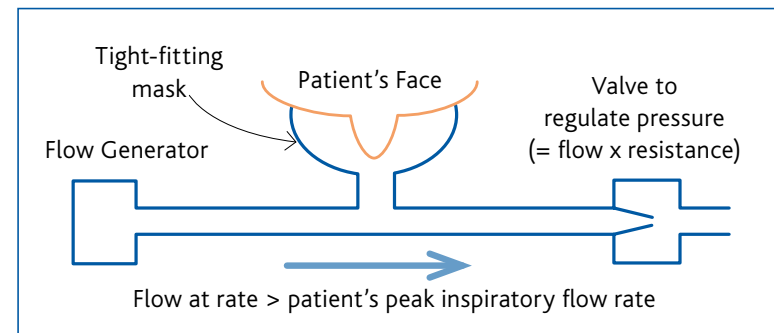

**Fig 7** Diagram of CPAP circuit



Fig 8a Face mask



Fig 8b CPAP valve and harness

Some patients are not suited to the use of CPAP masks, perhaps due to agitation or shape of face (a receding or prominent lower jaw may prove difficult). Extensive facial

hair can be a problem – perhaps resolved by shaving them (with consent).

When applying the face mask, it may be helpful to first allow the patient to hold it on themselves, as many patients may feel claustrophobic. The mask is then held on the face by the harness which passes around the back of the head. When tightening the straps, it is important to find a balance between leaving the mask loose and having a large leak and making it uncomfortably tight. The  $FiO_2$  initially chosen is usually slightly higher than that the patient received prior to CPAP. It is then adjusted to achieve the required  $SaO_2$ .

Not every hypoxaemic patient benefits from CPAP. In simple asthma, for instance, hypoxaemia is due to the plugging of small airways with thick sputum. CPAP will generally not resolve these issues, hinders humidification and use of nebulisers, and may also worsen overexpansion of other lung units. ‘Solid or blocked lung’ (e.g. lobar consolidation due to tumour or pneumonia) may have little gain, as the alveoli cannot be ‘reopened’. In such circumstances, application of CPAP may cause distress and be of limited advantage. Some COPD patients may benefit – but others may suffer hyperinflation of lung units, and thus a worsening of ventilation. However, this is often very hard to predict –and a trial of treatment is usually warranted: only 30-40% of ‘general hypoxaemic patients’ will ultimately require intubation if they *are* tried on CPAP or NIV ([📖 chapters 7 and 8](#)).

CPAP may improve oxygenation and its primary role is thus in Type I (hypoxaemic) respiratory failure. However, CPAP may also splint the upper airway open in patients with obstructive sleep apnoea, thus preventing the occurrence of



nocturnal desaturation and hypercarbia. In other conditions, too, alveolar recruitment may increase tidal and minute volume, and thus reduce CO<sub>2</sub> levels. This may be true of acute pulmonary oedema, where increased V<sub>D</sub>/V<sub>T</sub> (👉 page 28) may diminish alveolar ventilation, and respiratory muscle fatigue and obtundation may cause CO<sub>2</sub> to rise. ABGs are useful to assess changes in oxygenation and CO<sub>2</sub> clearance. A rising CO<sub>2</sub> may suggest over-inflation or fatigue and that non-invasive ventilator support (👉 chapter 8) or mechanical ventilation are needed.

### Complications of CPAP

CPAP is generally safe. Infrequent complications include pressure necrosis of skin, especially of the nasal bridge. Early application of a colloid dressing (or similar) may help avoid this. Under pressure, air can be swallowed, and gastric distension is not uncommon. This may cause discomfort, while resulting splinting of the diaphragm can cause basal atelectasis. If CPAP use is to be prolonged, parallel use of a nasogastric tube may be considered – although this may in fact worsen gastric distension by 'opening a track' through the cardiac sphincter. Air leak upwards may lead to corneal/conjunctival irritation. At its worst, ulceration results. This is potentially serious – so care must be taken to avoid substantial 'upward leak'. Pneumothorax can rarely complicate in patients at risk (e.g. trauma, COPD).

## 8 Non-invasive ventilation (NIV)

Although CPAP (👉 chapter 7) is a sort of non-invasive 'ventilatory' support, colloquially, people usually mean 'some form of positive pressure support' when talking about non-invasive ventilation, or 'NIV'. This 'pressure support' is needed when the work of breathing exceeds the patient's capacity to perform – due to weak or impaired muscle contraction (e.g. Guillain-Barre), very high work of breathing (e.g. massive ascites compressing the diaphragm, pulmonary oedema), or a combination (e.g. the cachectic COPD patient).

Normally, contraction of the inspiratory muscles expands the thoracic cavity volume, reducing intra-pleural, interstitial, and alveolar pressures further below atmospheric. Air is thus drawn into the lungs from the mouth cavity (which is, of course, at atmospheric pressure). Appropriate equipment can sense the start of gas flow ('flow sensing') or, more generally, the fall in pressure ('pressure sensing'), recognise it as the start of inspiration, and apply positive pressure at the mouth. The pressure gradient between mouth and alveoli is thus increased, gas flow into the lung augmented (with preferential inflation of the most compliant areas of the lung), and the inspiratory work of breathing reduced. Generally, this inspiratory positive pressure is used together with an elevated expiratory pressure (PEEP), helping to hold alveoli open. When applied by mask, this combination of PEEP and pressure support is often referred to as 'Non-Invasive Ventilation' or 'NIV' for short.

NIV is often used when the need for 'ventilatory' support is likely to be short-lived (acute pulmonary oedema), or where intubation may carry greater risks than benefits, or in patients with conditions leading to chronic type 2 respiratory failure. Application of NIV may prevent the need for endotracheal intubation in the latter which tends to increase dead space, generally requires sedation, limits mobility, may be distressing, and which prevents easy speech, oral nutrition, self-regulation of fluid intake and other aspects of self-caring. However, NIV should not delay intubation and mechanical ventilation when this is necessary.

## Equipment

The basic requirements are a pressure and flow generator ('ventilator'), ventilator tubing and the interface to connect the system to the patient. Portable non-invasive ventilators are widely used, both on the ICU and respiratory wards. Different models of varying complexity are available, although all are capable of providing high gas flows to maintain preset airway pressures at the end of expiration (expiratory positive airway pressure, or EPAP – really just another way of saying 'PEEP'), as well as sensing the respiratory effort made by the patient and delivering 'inspiratory positive airway pressure' (or IPAP). This application of two pressures is sometimes referred to as 'Bilevel Positive Airway Pressure' – or BiPAP. In most patients with acute respiratory failure, full face masks are used, and are more effective than nasal masks in lowering CO<sub>2</sub> concentrations.

The more advanced machines can deliver up to 100% O<sub>2</sub>, whereas the simpler machines require O<sub>2</sub> to be added to the distal breathing circuit through a side port. With this latter system the inspired O<sub>2</sub> concentration is variable, depending on flow within the circuit, and it is not possible to provide more than 60% inspired O<sub>2</sub>. This is important to consider when treating hypoxaemic patients.

Some machines are also capable of trying to deliver a set *volume* of air with each breath (up to a set maximum pressure) – by controlling inspiratory flow rate of gases, and duration of the inspiratory cycle (i.e. gas continues to be pushed in at a set rate and time, to deliver a set volume) – but such machines aren't able to recognise leaks around the mask. In general, pre-set pressure support and PEEP (as BiPAP) is used.

## Indications for NIV

By using a completely sealed system in which air cannot be entrained, CPAP/BiPAP circuits are able to deliver a truly accurate high concentration (FiO<sub>2</sub>=1.0) and are thus effective at treating hypoxia. Alveolar recruitment (and fall in V:Q mismatch, [page 22](#)) may also help. CPAP is thus indicated when alveolar recruitment may occur, and BiPAP/NIV when work of breathing requires augmentation.

The role of both CPAP and NIV in the management of **pulmonary oedema** is clearly established. A possible role in **asthma** is more contentious – and may limit administration of nebulisers.

- In the management of exacerbation of **chronic obstructive pulmonary disease (COPD)**, NIV is now the recommended first line therapy for patients with type 2 respiratory failure. Here, acute respiratory failure is often driven by increased work of breathing from dynamic airway collapse. These factors may prevent complete exhalation before the next inspiration starts, and 'dynamic hyperinflation' of the lungs results. The result is a positive pressure in the alveoli at the end of expiration ('intrinsic PEEP' climbs). This pressure needs to be overcome before inspiratory flow can occur. Inspiratory load is thus increased. Rapid, shallow respiration often results, which increases  $V_D/V_T$  ( page 28) and this, with respiratory muscle fatigue causes PaCO<sub>2</sub> to rise. NIV raises upper airway pressure reducing airway collapse, dynamic hyperinflation and intrinsic PEEP. Tidal volumes and CO<sub>2</sub> clearance increase, and respiratory rate falls. Intubation rates, mortality and ICU and hospital length of stay are reduced. Those who respond best are symptomatic patients with moderate respiratory acidosis (pH 7.25-7.35) in whom treatment is started early.
- Use of CPAP in **cardiogenic pulmonary oedema** recruits alveoli, reduces V:Q mismatch, improves oxygenation, and leads to more rapid resolution of symptoms. It also reduces work of breathing, increased by upper airway oedema, and repeated reopening of collapsed alveoli. Indeed, as much as 70% of total body O<sub>2</sub> consumption may be used by the respiratory muscles alone. BiPAP may be considered, especially if hypercarbia is identified, or when work of breathing seems especially raised.

- In **chest trauma**, NIV may reduce pain by offering some respiratory support.
- NIV may also have a role in **assisting in early extubation** of patients with background of COPD. In unselected patients, the use of NIV as a rescue therapy post extubation failure has shown to increase mortality.
- **Respiratory failure in immunosuppressed patients** can have a poor outcome: mortality rates (for instance, in bone marrow transplant patients) can be >90%. Especially in those with single organ failure due to opportunistic infection, a trial of NIV may improve their outcome by avoiding the risk of superadded ventilator-associated pneumonia. Several uncontrolled trials have shown NIV to be successful in about two-thirds of patients with AIDS, haematological malignancies, or pneumonia following lung transplantation.

### Contraindications to NIV

Absolute contraindications are few. However, NIV is generally best avoided, and intubation preferred, when:

- The patient cannot maintain/protect an airway (this may include bulbar palsies).
- Compliance is a problem, perhaps through agitation which can't be controlled.
- There is a risk of apnoea.
- Head or facial injuries.
- Relative contraindications include factors that make it difficult to create a seal with the mask (facial deformity or recent surgery), conditions where air swallowing may

cause problems (recent oesophageal/gastric surgery) and cases where frequent interruption of ventilation is required in order to clear copious secretions, small or large bowel obstruction.

- There is clear consolidation on the Chest X-ray (NIV increases mortality)

### Practical NIV issues

Selected  $\text{FiO}_2$  is slightly higher to that the patient received prior to NIV, and should be then adjusted to achieve a  $\text{SaO}_2$  appropriate for the underlying disease ([📖 page 44](#)).

EPAP is usually initially set at 5  $\text{cmH}_2\text{O}$ . IPAP (inspiratory positive airway pressure) is the total inspiratory pressure (which includes EPAP) and is commonly initially set at 10-15  $\text{cmH}_2\text{O}$ . The response to these pressures should be used to titrate IPAP to targets that usually are 20-30  $\text{cmH}_2\text{O}$  depending of tolerability and degree of mask leaks. Most machines can generate high pressures (although rarely used) of up to 40  $\text{cmH}_2\text{O}$ . If higher pressures are required, leakage around the mask is usually a problem, and conventional invasive ventilation may be indicated.

As for CPAP, measures of success include:

- Relief of dyspnoea: the patient 'feels better' and respiratory rate falls.
- Improvement in respiratory rate and pattern (due to improved oxygenation and reduced work of breathing relieving dyspnoea).
- Improvement in oxygenation:  $\text{FiO}_2$  may be increased, and EPAP adjusted to try to improve alveolar

recruitment, facilitate triggering in patients with high intrinsic PEEP.

- Reduction in  $\text{PaCO}_2$  and respiratory acidosis: IPAP can be increased, and should improve tidal volume.

It is important to observe the patient while on NIV, to ensure adequate synchronisation with the ventilator. Each patient effort should determine an increase in airway pressure and that the inspiratory phase does not continue after the patient starts to exhale. The most common cause of asynchrony is mask leaks: appropriate mask fitting is therefore essential.

All acute use of NIV should be considered a trial. If work of breathing increases, arterial gases do not improve adequately or worsen, or if there is a deterioration in the level of consciousness or tolerability, tracheal intubation and mechanical ventilation should be considered. This is best done 'electively', and not when crisis point has been reached.

### Complications of NIV

These are similar to those seen with CPAP ([📖 page 64](#)).

### Cardiovascular effects of positive pressure ventilation

Normal inspiration is associated with a negative intrathoracic pressure, which draws venous blood into the right atrium, and expands the pulmonary vascular bed, lowering pulmonary vascular resistance and increasing the volume of 'blood held' in the lungs. Right ventricular stroke volume thus rises a little during slow inspiration, while left ventricular output

falls slightly. The reverse is true of the expiratory phase. During mandatory positive pressure ventilation there is an increase in intrathoracic pressure and a fall in venous return, right ventricular output, and pulmonary blood flow on inspiration. On expiration, the intrathoracic pressure falls and the venous return increases. *In other words, the normal respiratory cycle of cardiac filling and emptying is reversed.* Positive intrathoracic pressures from PEEP also inhibit venous return.

Overall, then, positive pressure ventilation means that *right ventricular preload is reduced*:

- positive intrathoracic pressure decreases the pressure gradient for venous inflow into the thorax.
- positive pressure exerted on the outer surface of the heart reduces cardiac distensibility, and this diastolic ventricular filling.
- compression of pulmonary blood vessels raises pulmonary vascular resistance which impedes right ventricular (RV) stroke output (i.e. increase RV *afterload*), causing the RV to dilate, the interventricular septum to bulge into the left ventricular (LV) cavity, LV chamber size to fall, and thus LV diastolic filling to reduce.

As a counterbalance, *cardiac compressive effects during systole tend to have a positive effect on systolic ejection*, ('like the hand squeezing the ventricle during systole'). Thus, positive-pressure ventilation tends to reduce ventricular filling during diastole but enhances ventricular emptying during systole. The overall effect on cardiac output will depend on whether the effect on preload or afterload

predominate, and how sensitive the heart is to these changes (by nature of cardiac disease, or existing loading/filling conditions). When intravascular volume is normal and intrathoracic pressures are not excessive, the effect on afterload reduction predominates, and positive pressure ventilation increases cardiac stroke output. However, in hypovolaemia the predominant effect is to reduce ventricular preload, and CO.

Positive pressure ventilation also impedes lymphatic flow: raised pulmonary interstitial pressures (including that from PEEP) compress thin-walled peripheral lymphatics. Positive pressure ventilation (and PEEP) can, at high levels, thus increase lung water: PEEP helps remove fluid from alveoli, but the reduction in thoracic duct drainage can result in interstitial fluid retention and pleural effusions. Whole body salt and water retention can also be encouraged: high venous pressures encourage oedema, and effects on atrial loading can promote antidiuretic hormone secretion and inhibit release of natriuretic peptides.

Such effects are rarely of clinical importance in using NIV, however, and may have greater impacts during prolonged invasive mechanical positive pressure ventilation, with which we shall deal in the following chapters.

## 9 Artificial airways

Mandatory mechanical ventilation is hard to deliver non-invasively. A secure airway is thus required. This may be either an orotracheal airway – colloquially known as an endotracheal tube (naso-tracheal tubes are infrequently used nowadays), or a tracheostomy.

### Endotracheal tubes

Endotracheal tubes provide a means of securing a patient's airway (i.e. ensuring access to the trachea for ventilation, whilst limiting contamination from the pharynx).

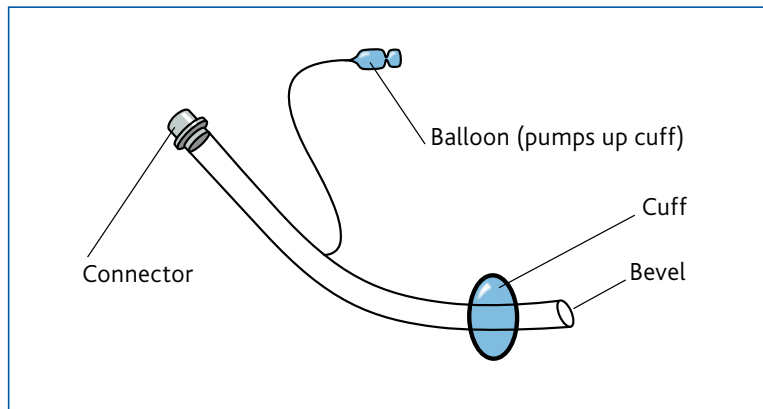

Fig 9 Endotracheal tube

They are equipped with an inflatable balloon at the distal end (the cuff) that is used to seal the trachea and prevent positive

pressure inflation volumes from escaping through the larynx, and guard the lungs from the entry of oropharyngeal or stomach contents from above. Whilst the proximal end has a standard 15 mm connector, the tubes vary in length from 25 to 35 cm and are sized according to their internal diameter. Size 8-9 mm will fit to most men and size 7-8 mm to most women. The length is marked in centimetres on the outside of the tube (👁 Fig 9, opposite).

Delayed complications are caused by pressure-induced injury of the surrounding tissues: obstruction of the maxillary antrum causing sinusitis (for nasal intubations), laryngeal or tracheal granulation tissue and obstruction, and tracheal erosion (causing haemorrhage).

#### Correct position

For orotracheal intubations, the length from the tip to the teeth is normally about 20-22 cm in women and 21-24 cm in men. However, a CXR soon after intubation is mandatory, as entry into the right main bronchus can readily occur, and it is important to assess the height of the tube above the carina. A tube ending 3-5 cm above the carina with the head in a neutral position is usually ideal. The tube can be 'cut' to ensure that it is not too long – although different ICUs sometimes have strong views as to whether to do this or not! Tube length at the lips should be noted, and regular nursing checks made to ensure that the tube does not slip too far inwards. N.B. flexion and extension of the neck causes a 2 cm displacement of the endotracheal tube tip.

### Endotracheal tubes and work of breathing

Resistance to flow through the ETT is directly related to its length, and to the 4th power of the fall in the radius. In general, therefore, ETT diameter should be >8 mm for patients admitted to the ICU. A patient who is ventilated for a more prolonged period may build up biofilm on the internal lumen and this effectively reduces the working diameter. It should also be remembered that if an ICU patient needs a bronchoscopy, then it is tricky to safely bronchoscope a patient with a tube size <8 mm. Whenever a patient is intubated, work of spontaneous breathing is typically increased. It is often stated that pressure support of 6-8 cmH<sub>2</sub>O with an ETT in place equates to the 'normal' work of breathing in a non-intubated patient.

### Endotracheal tubes and ventilator-associated pneumonia (VAP)

It is becoming increasingly apparent that aspiration of contaminated oropharyngeal secretions and the development of a biofilm within the ETT lead to VAP. Therefore a variety of 'modified' ETTs are now available, and have been shown to reduce the incidence of VAP. Hence there are two main strategies used to try to decrease VAP:

#### 1 *Reduction of pulmonary aspiration of oropharyngeal secretions:*

- a *Subglottic secretion drainage:*  
ETT with an additional suction port situated above the cuff to allow aspiration of oropharyngeal secretions that pool above the cuff;

- b *Modified (thin) polyurethane-cuffs:*  
These cuffs limit the formation of folds within the cuff which contribute to microaspiration;
- c *Cuff pressure measurement:*  
Numerous devices are now available to maintain cuff pressure within the ideal range of 20-30 cmH<sub>2</sub>O.

#### 2 *Reduction in the formation of biofilm on the internal lumen*

- a *Silver-coated ETTs:*  
reduce biofilm formation and may reduce VAP;
- b *Mucus Shaver:*  
Inflatable silicone-rubber 'razor' to remove mucus and biofilm from the lumen of the ETT.

## 10 Cricothyroidotomy

This is NOT the same as tracheostomy. It is a quite different procedure, in which the trachea is entered through the cricothyroid membrane.

*Minitrachs:* Access with a small tube (a 'minitrach') can aid suctioning of secretions in those with poor clearance.

*Needle cricothyroidotomy:* This is a life-saving airway procedure which is undertaken in a time-critical situation. This technique provides jet insufflation of O<sub>2</sub> to the partially obstructed airway.

### Briefly, this is how it is done:

- Prepare O<sub>2</sub> tubing – either a side hole is cut in the tubing near one end, or a Y-connector is attached. The other end is connected to an O<sub>2</sub> source.
- Position the patient supine, with the neck neutral or slightly extended, and prepare the skin with antiseptic, and then infiltrate with local anaesthetic (e.g. 2ml 1% lidocaine with adrenaline 1:200,000).
- Attach a 12 (or 14G) IV cannula to a 10ml syringe.
- Between the thyroid cartilage and cricoid cartilage, palpate the cricothyroid membrane in the midline. With the thumb and forefinger of your non-dominant hand stabilise the trachea to prevent lateral movement.

- Puncture the membrane with the needle, directed 45° angle towards the chest, whilst gently aspirating the syringe. Aspiration of air confirms entry into the trachea.
- Remove the needle whilst carefully advancing the cannula sheath downwards. Care must be taken not to perforate the posterior wall of the trachea.
- Attach O<sub>2</sub> tubing to the hub of the catheter, and secure the catheter to the patient's neck. A vigilant assistant should hold the cannula to prevent kinking. Intermittent ventilation is achieved by occlusion of the hole in the tubing for 1 second, then releasing it for 4 seconds. Passive exhalation (via the oro/nasopharynx, not via the cannula) can occur when the hole is not occluded.

Adequate oxygenation can only be provided for up to 45 minutes (the principal limitation being a steady accumulation in arterial CO<sub>2</sub>), but it can be used to buy time whilst expert assistance or equipment (e.g. fiberoptic intubation) is prepared. Close observation is mandatory!

### Complications include:

- Inadequate ventilation leading to hypoxia and death. If the airway is obstructed proximal to the cannula, the patient is unlikely to be able to overcome the obstruction at exhalation and a surgical cricothyroidotomy should be considered immediately. In this situation, only small volumes of O<sub>2</sub> should be



insufflated as excess gas volume cannot be expelled. There is also a distinct possibility that small-gauge cannulae can readily become blocked and kinked.

- Bleeding, leading to haematoma formation and/or aspiration with associated pneumonitis.
- Oesophageal, thyroid, or posterior tracheal wall perforation, and pneumothorax.
- Subcutaneous or mediastinal emphysema.

**Surgical cricothyroidotomy:** This provides a more definitive airway when the upper airway is compromised by trauma, infection or swelling, and oro- or nasotracheal intubation is not possible.

**Briefly, this is how it is done:**

- As for a needle cricothyroidotomy (*see above*), the patient should be positioned supine, with the neck in a neutral position. The neck is prepared with antiseptic, and if the patient is awake and time allows, local anaesthetic (e.g. 2ml 1% lidocaine with adrenaline 1:200,000) should be infiltrated.
- Stabilise the thyroid cartilage with the non-dominant hand to prevent lateral movement during the procedure.
- Make a transverse skin incision over the cricothyroid membrane, and then through the cricothyroid membrane (👉 *Fig 10, opposite*).

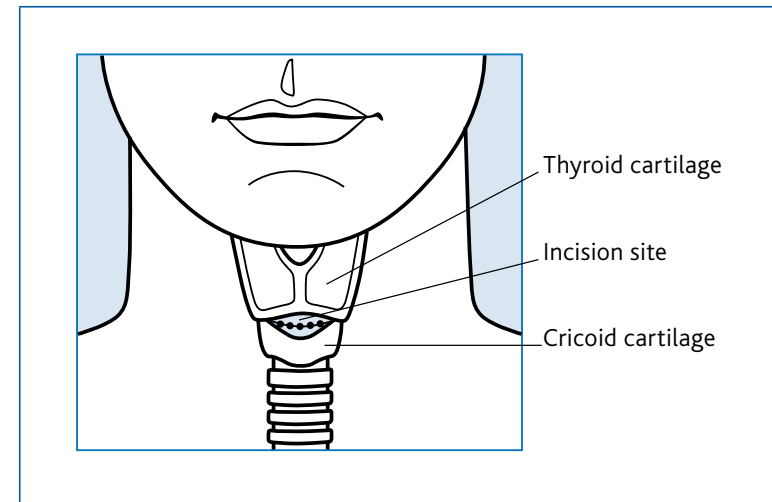

**Fig 10 Cricothyroidotomy**

- Insert the handle of the scalpel (NOT plastic ones, which can snap) through the incision, and rotate by 90° to dilate the opening in the airway. If available, curved artery forceps (e.g. a haemostat) or a tracheal spreader may then be used to open the airway.
- Insert an appropriately sized cuffed endotracheal (usually 5-7 mm internal diameter) or a tracheostomy tube. The tube should be directed caudally.
- Inflate the cuff and ventilate the patient. Then secure the tube adequately.
- Auscultate the chest and observe for equal chest expansion.

Emergency cricothyroidotomy is, however, associated with a high incidence of laryngeal stenosis and subglottic stenosis. A more formal tracheostomy should then be substituted at the earliest opportunity.

**Other complications include:**

- Haemorrhage and haematoma formation, and aspiration
- False passage creation
- Oesophageal or tracheal laceration
- Vocal cord paralysis
- Mediastinal and subcutaneous emphysema

## 11 Tracheostomies

A tracheostomy is an artificial airway inserted between the 1st and 4th tracheal rings ( *Fig 11, page 84*). In the ICU, the commonest indication for a tracheostomy is the requirement for prolonged mechanical ventilation.

**Advantages of tracheostomy:**

- 1 Greater patient comfort (and less sedation, promoting active participation in weaning and rehabilitation);
- 2 Reduced tube length (and dead space) and therefore decreased work of breathing;
- 3 Improved mouth care;
- 4 Allows alternate periods on and off mechanical ventilation, aiding weaning;
- 5 Continued access to the patient's airway whilst on or off mechanical ventilation thus allowing regular suction of tracheal secretions;
- 6 Continued airway protection (for instance, in those with bulbar palsies, or significant cerebral injury);
- 7 Oral intake, and even the chance to speak (if specially designed tubes and valves are used).

The main disadvantage of the tracheostomy tube is its insertion site. As the oropharynx is effectively dissociated

from the trachea, our normal methods of warming, filtering and humidifying atmospheric air is bypassed. It is thus important that heated humidification is used when delivering O<sub>2</sub>.

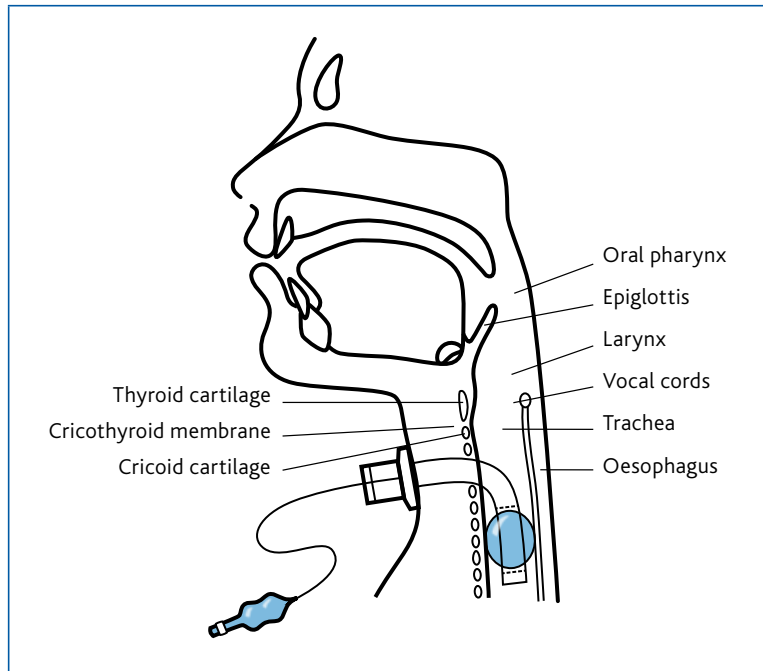

Fig 11 Tracheostomy: Position and anatomical landmarks

### Techniques of insertion

Tracheostomies can be performed as an open surgical procedure, or by percutaneous placement of the tracheostomy tube at the bedside (using a number of different methods). Greater than 90% of tracheostomies are now performed in the ICU by a percutaneous procedure.

### Complications

Combining surgical and percutaneous techniques for tracheostomy insertion, mortality rates are <0.25%, and significant adverse events occur in <3% of cases.

#### Early complications include:

- *Loss of control of the airway during insertion* (with inadequate ventilation, or aspiration pneumonia): for this reason, NEVER offer to help 'at the top end' unless you are experienced or fully supervised.
- *Local bleeding* (simple skin diathermy can help but beware substantial endotracheal blood loss, clot can form and obstruct the bronchi, which can be life-threatening).
- *Subcutaneous emphysema/pneumothorax* (especially from damage to the posterior tracheal wall).
- *Tube blockage* (dislodged into the subcutaneous space, cuff herniation, occlusion of the tube tip against carina or tracheal wall).

After about 1 week, a stoma 'track' forms. Before that, accidental decannulation can lead to immediate loss of the airway, and blind reinsertion often creates false passages in subcutaneous tissues. Endotracheal intubation may be the safest way of re-establishing an airway in this situation.

**Late complications include:**

- Subglottic or tracheal stenosis.
- Rarely, erosion into the innominate artery can cause catastrophic haemorrhage.

**Cuffed and uncuffed tubes**

Tracheostomy tubes vary in size, and can be cuffed or uncuffed. Cuffs are connected to a small pilot balloon through which they can be inflated. Air is injected until there is no evidence of leak around a cuff (i.e. no air comes out of the mouth during positive pressure ventilation) suggesting an airtight seal between the tracheal tube and tracheal wall. The use of a cuffed tracheostomy permits airflow to and from the lungs but also restricts airflow to the vocal cords and limits oral secretions from being aspirated into the lungs. Uncuffed tubes may be used in those with good bulbar function in whom a patent airway with access for suctioning is needed.

**Cuffs can be:**

- 1 **High pressure-low volume**  
(can prevent the passing of vomitus, secretions or blood into the lungs: if left in position for long periods can cause necrosis of the tracheal mucosa).
- 2 **Low pressure-high volume**  
(minimises risk of pressure-induced tracheal injury).

In any event, cuff pressure should not exceed 25 mmHg (~ 35 cmH<sub>2</sub>O).

Cuff leaks (air from the mouth) may be because cuff pressure is too low (has the cuff got a small hole and is deflating?), or because contact between tracheal wall and the cuff is non-uniform. If the pressure in the cuff exceeds 35 cmH<sub>2</sub>O, or the leak persists despite adding volume, the tracheostomy tube may need to be replaced with a larger size or a longer length tube, or a high-volume cuffed tube.

**Fenestrated and non-fenestrated tubes**

Some tubes are supplied with an inner cannula, which can be regularly removed and cleaned (preventing build-up of dried secretions which can otherwise block the tube).

**Tubes can also be:**

- 1 **Non-fenestrated**  
(solid outer and solid inner tube). This is usually the first choice for the ventilated patient as it limits airflow to oropharynx or subcutaneous tissues via incision site.
- 2 **Fenestrated**  
With these tubes, the outer tube has holes/perforations in it. They come with an optional set of inner tubes: solid (used when the patient is on the ventilator – essentially making the tube act as a ‘non-fenestrated’ tube) or one with holes/perforations to match the outer tube (used during cuff deflation) which allows airflow up to vocal cords and oropharynx, and hence speech is possible if the patient is strong enough (👉 Fig 12, page 88).

### Subglottic suction ports

As discussed for ETT – subglottic suction ports allow suction of secretions and reduce pulmonary aspiration and the incidence of VAP.

### Speaking valves

These are one-way valves attached to tracheostomy tubes that open during inspiration (allowing inflow of air) and close during expiration to allow air to escape through the vocal cords and generate a voice. Several types of speaking valves exist with different resistance and comfort. The speaking valve contains a movable plastic disc that opens on inspiration but closes on expiration. This means that during expiration no air can escape through the tracheostomy tube opening. It is redirected up through the larynx instead (🔗 *Fig 27, page 165*).

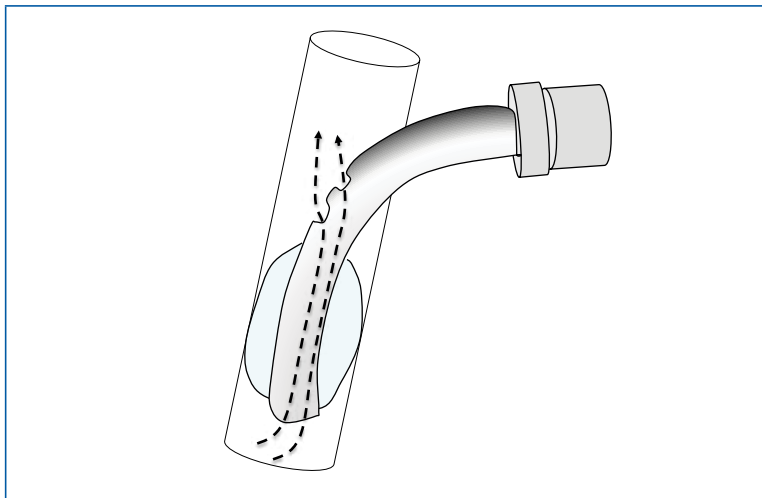

**Fig 12** Fenestrated tracheostomy tubes: holes in the tube allows airflow (dashed arrows) up to the vocal cords

## 12 Invasive positive pressure mechanical ventilation

A ventilator creates a pressure differential to deliver gas into the lungs, and then lets it out again. There are several different types, some of which you are only likely to see in very specialist units:

- 1 Negative pressure ventilators work in a more physiological way. Sealed boxes wrapped around the patient's chest ('cuirass') expand, or a whole-body box (with just the head and neck poking out – an 'iron lung') has its internal pressure lowered. The rib cage is sucked out, intrathoracic pressure falls, and air is drawn into the mouth.
- 2 High frequency oscillators (Jet ventilators are infrequently seen).
- 3 Rocking beds (these tip the patient head up and head down, using the weight of the abdominal contents to compress and expand the lungs).

In addition, other machines can 'take over' lung function by directly oxygenating the blood and/or clearing CO<sub>2</sub> from it – extracorporeal membrane oxygenation/ extracorporeal CO<sub>2</sub> removal – ECMO/ECCO<sub>2</sub>R (🔗 *page 185*).

In general, you will be exposed (in adult practice) to *positive pressure ventilators*, which inflate lungs under positive

pressure. These are generally powered by electrical (mains or battery) means, although some (especially portable machines) use pneumatic (gas cylinder/gas port) power.

Mechanical ventilators are comprised of four main elements:

- 1 A source of pressurised gas including a blender for air and O<sub>2</sub>.
- 2 An inspiratory valve, expiratory valve and ventilator circuit.
- 3 A control system, including control panel, monitoring and alarms.
- 4 A system to sense when the patient is trying to take breath.

### Modes of ventilatory support

ICU ventilators can be very confusing because of the array of different modes. Unfortunately there is no standard nomenclature in use and modes that are essentially the same can have quite different names according to the ventilator manufacturer. However most modes can be classified according to the following questions:

- 1 How is the breath delivered: a preset pressure, or a preset volume?
- 2 Are the breaths delivered at a set frequency (controlled mode), in response to patient's respiratory efforts (spontaneous mode) or a combination of both (assist-control or spontaneous-assisted).

The modes that are in common use are outlined below:

- **Volume control** (also known as *Continuous Mandatory Ventilation [CMV], Intermittent Positive Pressure Ventilation [IPPV]*).  
In this mode you set the ventilator to give a breath of a certain tidal volume ( $V_T$ ) over a certain time period and at a set frequency (respiratory rate). The preset volume to be delivered is set on the ventilator, and the flow required to generate that volume will be delivered over a preset period of time or at a preset flow rate (e.g. 0.5-2L/second). The driving pressure (peak pressure minus PEEP) needed to achieve each will vary significantly depending on the patient's respiratory mechanics. In volume control, the set number of breaths can be considered the minimum rate as it is possible to allow additional breaths to be delivered if the patient makes respiratory efforts more often than the preset rate (assisted breaths).
- **Pressure Control (PCV)**  
The ventilator is set to expose the airway to a certain pressure for a certain period of time and at a set frequency. The volume delivered will depend upon how 'stretchy' or compliant the lungs and chest wall are: if compliance is low, then a high pressure may still deliver a low tidal volume. The same goes if airway resistance increases (for instance, with asthma or mucus narrowing the airways). One danger is unrecognised under ventilation: if compliance falls, so will  $V_T$ . Modern ventilators have alarms to alert you to this issue. Another danger is that if compliance increases (e.g. due to diuresis reducing pulmonary oedema or to resolution of pneumonia) then the lungs become more stretchy

and the  $V_T$  increases for a given driving pressure. This can result in over-distension of the alveoli (volutrauma), so close attention must be paid to the delivered  $V_T$  in PCV modes. PCV will allow additional breaths to be delivered above the set frequency in response to patient's respiratory efforts. One advantage compared to volume controlled modes is improved comfort during these patient's initiated breaths, as the inspiratory flow is not fixed and will vary according to the patient's efforts and lung mechanics.

- Pressure support (PS, or ASB/Assisted Spontaneous Breathing)**  
 The ventilator delivers assists inspiration by increasing airway pressure in response to the patient's spontaneous breathing efforts. The level of inspiratory assist or pressure support is the difference between the set maximum inspiratory and expiratory pressures. Inspiratory time is not set but determined by the duration of the patient's inspiratory effort. The speed of the initial pressurisation (sometimes referred to as ramp) can be adjusted on some ventilators to attempt to match patient's respiratory drive or lung mechanics. The inspiration ends when the ventilator senses a fall in inspiratory below a certain percentage of the peak inspiratory flow (usually below 25%, but can be modified). Pressure support is a spontaneous mode and the patient must have a normal respiratory drive as no breaths will be delivered if the patient stops breathing. However, most ventilators have apnoea alarms and deliver back-up breaths in controlled mode should the patient become apnoeic. Pressure support can be

considered a partial method of ventilatory support and is frequently used as the patient improves and during weaning (👉 Figs 13, below and 14, page 94).

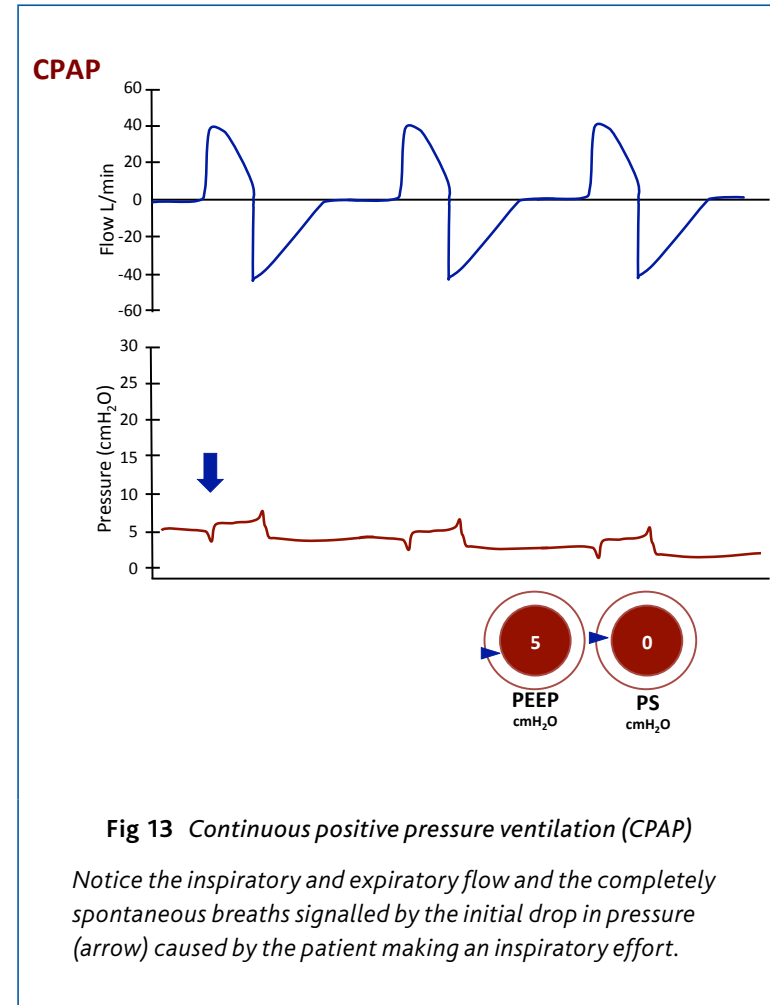

**Fig 13** Continuous positive pressure ventilation (CPAP)

Notice the inspiratory and expiratory flow and the completely spontaneous breaths signalled by the initial drop in pressure (arrow) caused by the patient making an inspiratory effort.

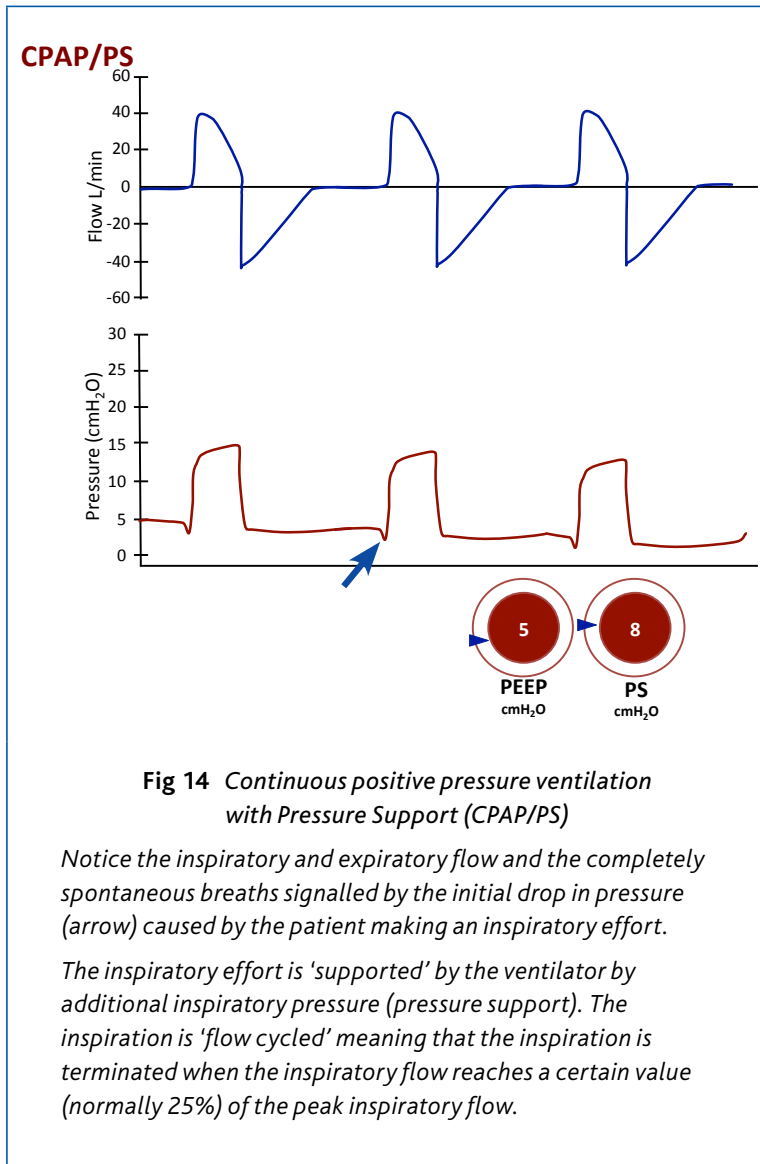

- **Assist-Control (AC)**

It is a mixed mode in which patients receive a mandatory breath with set tidal volume (if volume AC) or pressure (pressure AC). The mandatory breath can be fully controlled if the patient is not triggering the ventilator or assisted if the patient is able to trigger the ventilator (👉 Fig 15, below).

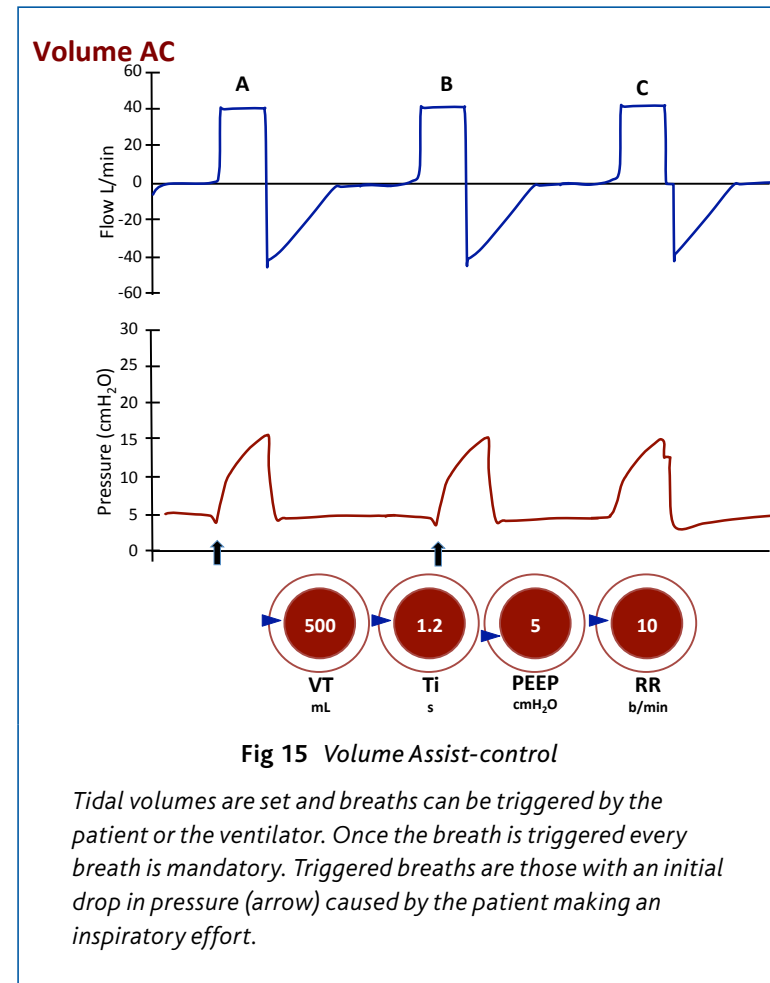



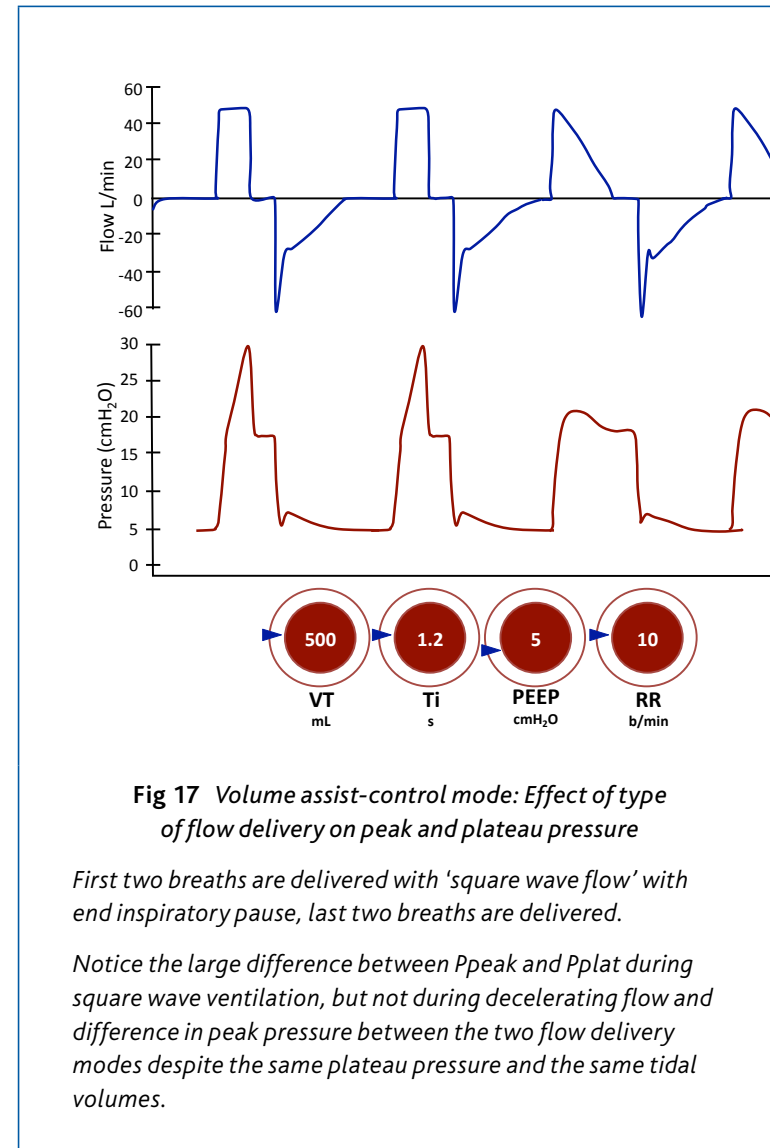
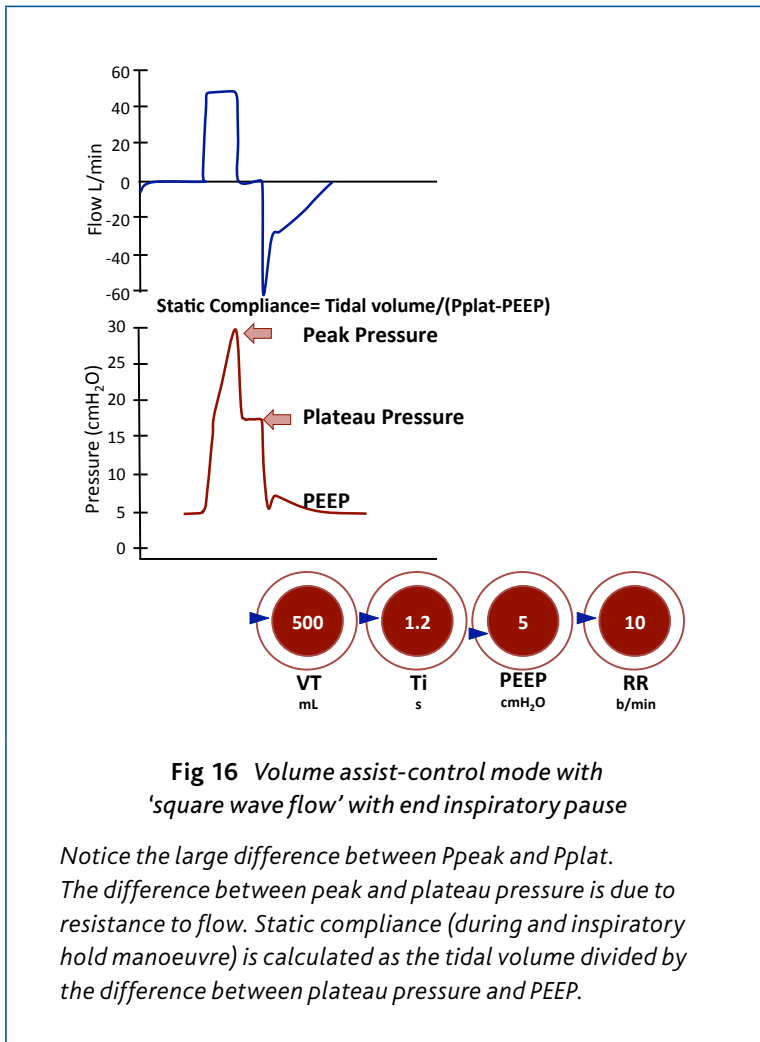

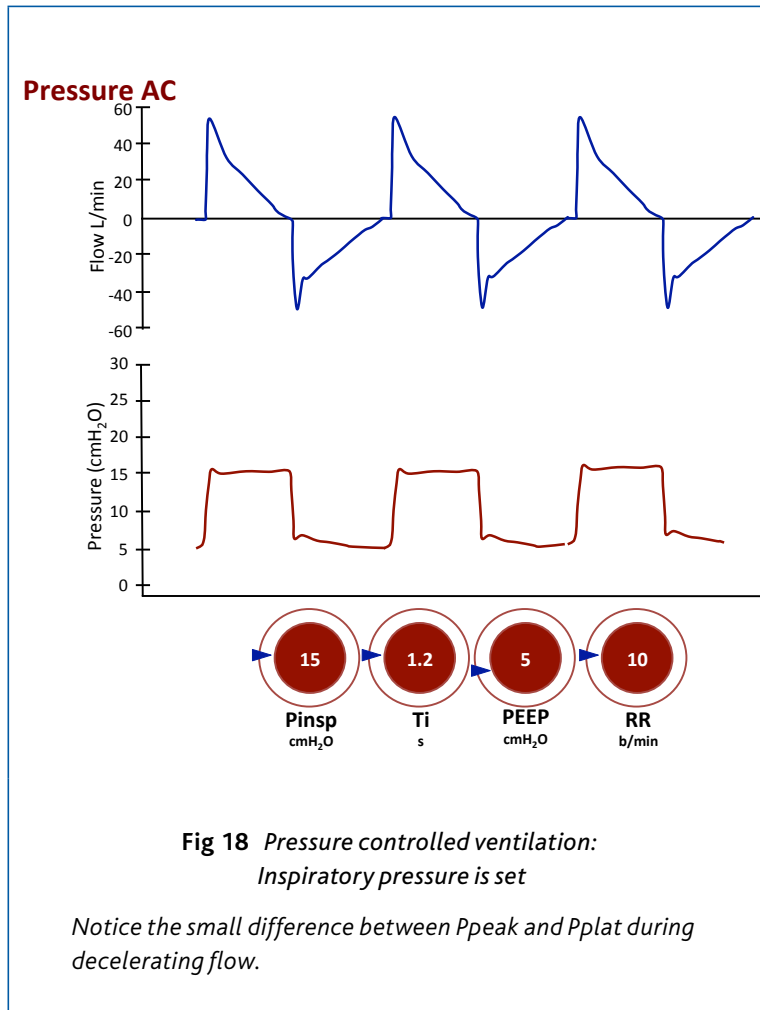

- **Synchronised intermittent mandatory ventilation (SIMV)**  
This is a mixed mode which combines mandatory controlled breaths and spontaneous pressure supported breaths. The mandatory breaths can either be volume controlled or pressure controlled breaths. If the patient makes no respiratory effort the mandatory breaths are delivered at a regular frequency and the mode is effectively the same as volume or pressure control. The difference with SIMV is how the ventilator responds to patient effort. If inspiratory effort is made when a mandatory breath is due ('synchronisation' time window), then the ventilator will synchronise with the patient's efforts and deliver the set mandatory breath. However, if the patient is breathing at a rate greater than the set rate then the ventilator will deliver a pressure supported breath for each of the patient breaths above the pre-set frequency. SIMV was originally introduced as a method of weaning although now most clinicians will switch the patient to pressure support alone once the patient has an adequate respiratory drive (👉 Figs 19-21).

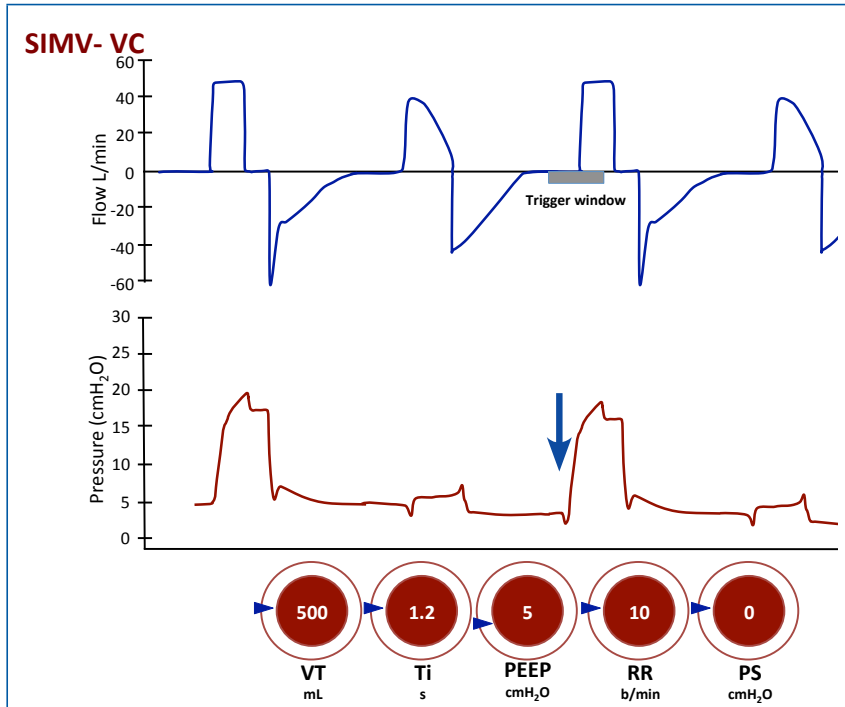

**Fig 19 Synchronized-Intermittent mandatory ventilation (SIMV-VC)**

Tidal volumes are set and breaths can be triggered by the patient or the ventilator. Once the breath is triggered every breath is mandatory if they occur during the time of the 'trigger window'. Triggered breaths are those with an initial drop in pressure (arrow) caused by the patient making an inspiratory effort. If inspiratory efforts occur outside the 'trigger window' and are more frequent than the set respiratory rate they are spontaneous breaths like CPAP.

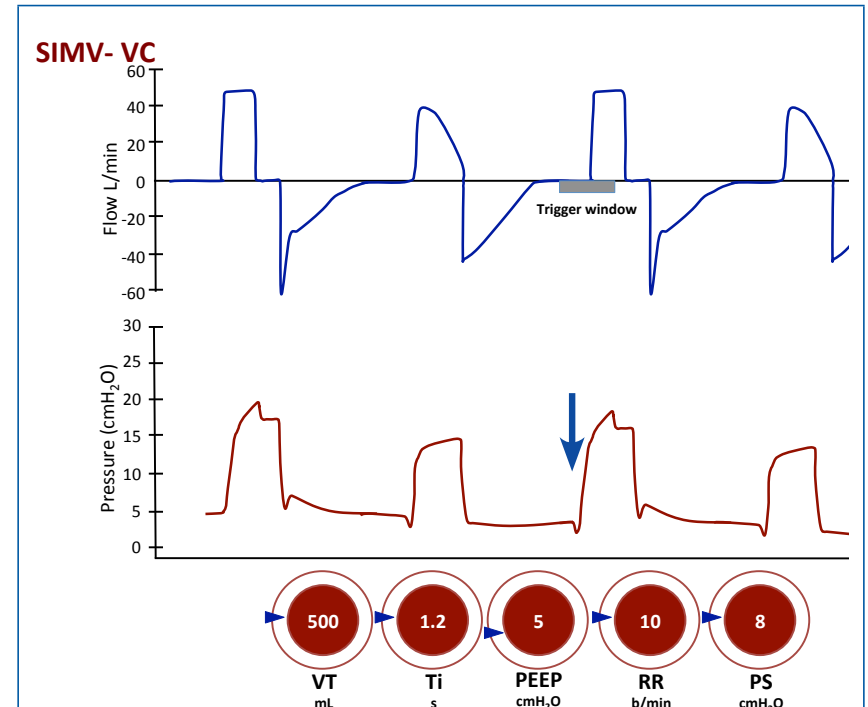

**Fig 20 Synchronized-Intermittent mandatory ventilation (SIMV)**

Tidal volumes are set and breaths can be triggered by the patient or the ventilator. Once the breath is triggered every breath is mandatory if they occur during the time of the 'trigger window'. Triggered breaths are those with an initial drop in pressure (arrow) caused by the patient making an inspiratory effort. If inspiratory efforts occur outside the 'trigger window' and are more frequent than the set respiratory rate they are spontaneous supported breaths like CPAP/PS

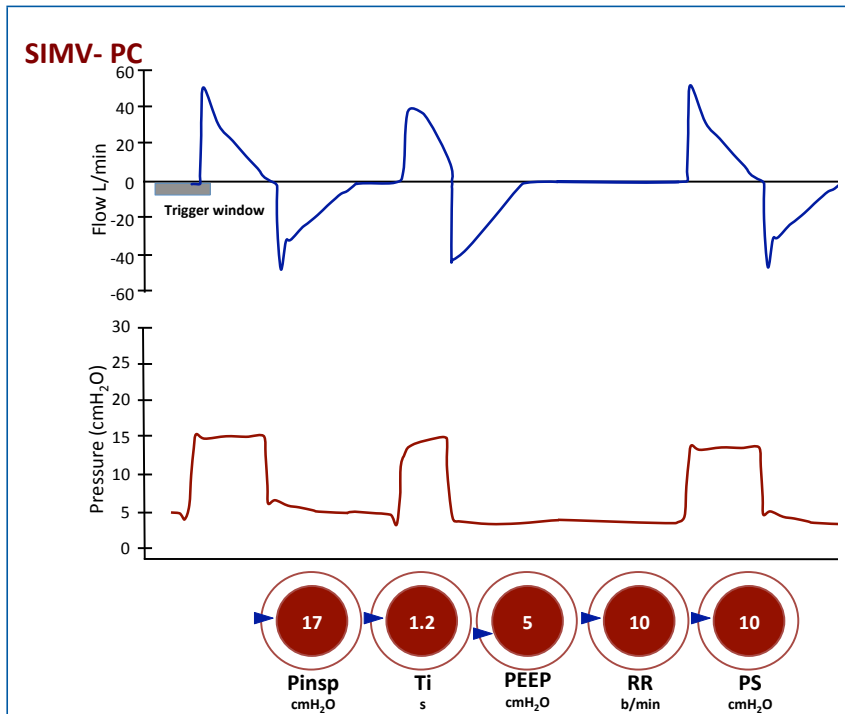

**Fig 21** Synchronized-Intermittent mandatory ventilation (SIMV-PC)

Inspiratory pressures are set and breaths can be triggered by the patient or the ventilator. Once the breath is triggered every breath is mandatory if they occur during the time of the 'trigger window'. Triggered breaths are those with an initial drop in pressure caused by the patient making an inspiratory effort. If inspiratory efforts occur outside the 'trigger window' and are more frequent than the set respiratory rate they are spontaneous supported breaths like CPAP/PS.

- **Airway pressure release ventilation (APRV)**  
Maintains a high airway pressure (high CPAP) for a prolonged period (e.g. 4-5 seconds), intermittently 'releasing' for short periods at a lower pressure

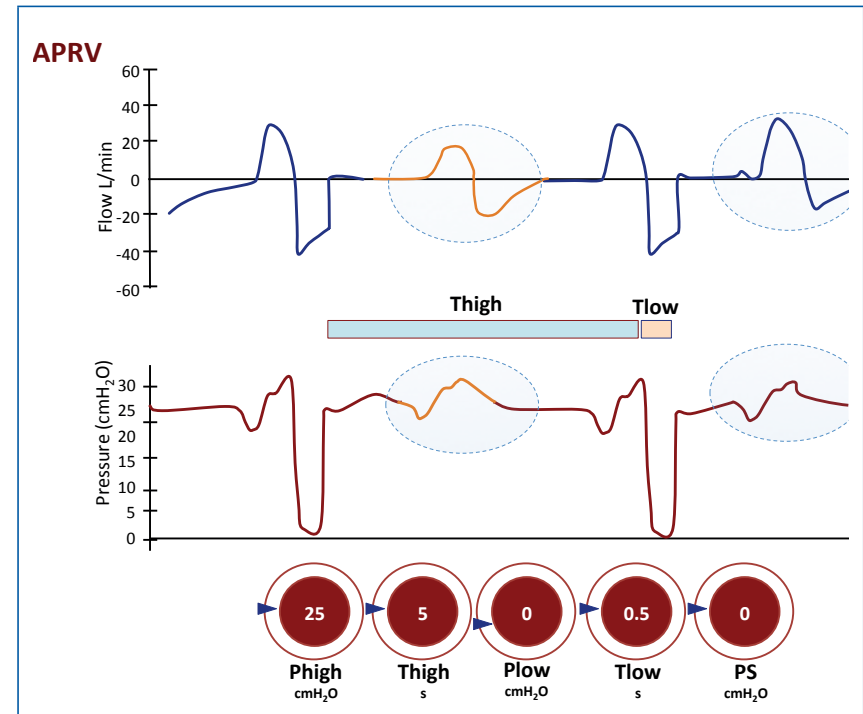

**Fig 22** Airway pressure release ventilation (APRV)

Is similar to continuous positive airway pressure (CPAP) where P<sub>high</sub> is the CPAP level with a duration of T<sub>high</sub>. Intermittently every few seconds (T<sub>high</sub>), the CPAP phase is intermittently released to a P<sub>low</sub> for a fraction of a second (T<sub>low</sub>) to allow some release of pressure but not long enough to deflate the lung. Spontaneous breathing occurs throughout (notice CPAP shape of the waveforms in the circled shaded areas).

- ( $<0.5$  seconds). The V<sub>T</sub> that is delivered with each breath will depend upon the difference between the set high (inspiratory) and low (expiratory) pressures, and the compliance of the lungs (👉 Fig 22, above).

- **BiLevel (BIPAP/biphasic positive airway pressure) ventilation**

BIPAP is PCV with spontaneous breathing permitted throughout the respiratory cycle. A cleverly-designed valve permits spontaneous breathing at either the upper or lower CPAP level. Breaths can be pressure-supported.

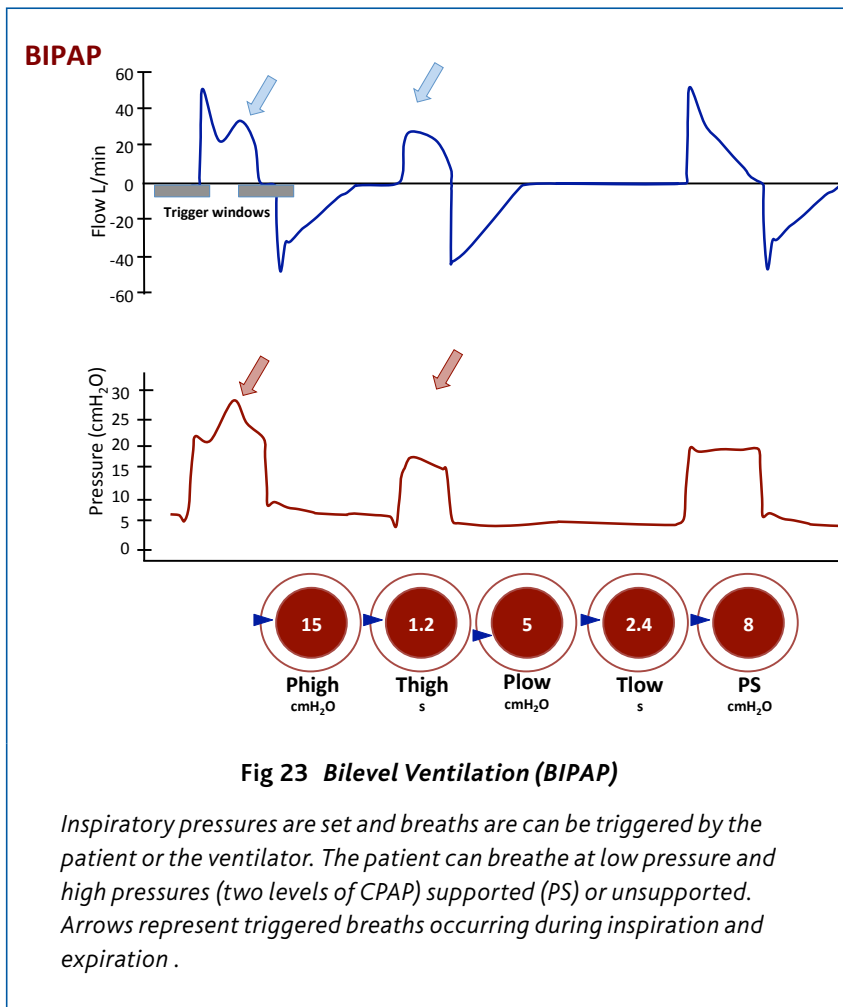

Inspiratory to Expiratory ratios (I:E ratios, see below) are usually 8 or 9:1. If the patient is not making any spontaneous efforts and the frequency and I:E ratio are set at conventional values then bi-level is identical to normal pressure control (👉 Fig 23, opposite).

### Triggering – what triggers the machine to start deliver a breath?

#### 1 Pressure sensing

The machine senses the drop in pressure in the ventilator circuit as the patient tries to breathe in. The problem with pressure sensing is that ventilator circuits are big and made of flexible plastic – so quite a big breath/effort may be needed before a sufficient pressure drop is generated. By then, the patient may be trying to breathe out – just as the ventilator blows air in again! This results in the patient failing to synchronise breathing with the ventilator.

#### 2 Volume/flow sensing

Here, there is a constant gas flow through the ventilator circuit – and the amount of gas returning is compared to the amount flowing out. A small discrepancy is taken to mean that the patient is drawing some gas in – and a breath is then triggered. In general, flow sensing is more sensitive than pressure sensing, and 'good synchronisation' more likely.

#### 3 Neurally adjusted ventilator assist (NAVA)

This is a specific mode of ventilation that senses

the electrical activity of the diaphragm – via an oesophageal electrode to trigger inspiration and cycle to expiration. The NAVA mode (Maquet® Servo-i), triggers the ventilator from the electrical activity of the diaphragm (EAdi), as opposed to flow or pressure. During NAVA, the airway pressure instantaneously reflects the patient's respiratory drive and is not influenced by changes in respiratory mechanics or failure of the ventilator circuit (e.g., leaks), therefore offering optimal patient–ventilator interaction and work of breathing. EAdi is obtained from the crural portion of the diaphragm via a nasogastric tube with an array of nine electrodes and displayed as a waveform, whose x-axis is time and y-axis is mV. With NAVA, the ventilator applies pressure to the airway opening throughout inspiration in proportion to the EAdi signal that is multiplied by an adjustable gain constant, expressed in cmH<sub>2</sub>O/mV, referred to as 'NAVA level'.

### Cycling – what causes the switch from inspiration to expiration?

Four methods can be used to make the machine switch from inspiration to expiration:

- a Time cycling**  
The inspiratory phase is set to last for a fixed period of time, after which the ventilator will automatically switch to the expiratory phase;

- b Volume cycling**  
When the preset  $V_T$  has been delivered the ventilator will switch to the expiratory phase;
- c Pressure cycling**  
The inspiratory phase lasts until a preset level of pressure is reached at which point the switch to expiration occurs; and
- d Flow cycling**  
The inspiratory phase switches when the gas flow falls below a certain level (i.e. once the breath is complete).

In all cases, the volume of each breath is recorded usually by measuring the amount of gas returning to the ventilator. This can cause problems in cases where there is substantial air leak through a chest drain.

### Inspiratory time and I:E ratio

Normally (for you and I), one spends 1 second breathing in for every 2-3 seconds breathing out (inspiratory: expiratory ratio, I:E, of 1:2-3). In controlled modes of ventilatory support the duration of the inspiration needs to be set either by adjusting the I:E ratio or the inspiratory time. Typically a ventilator is set with an I:E ratio of 1:2 or 1:3 or an inspiratory time of 1-1.5 seconds. However, sometimes the I:E ratio is shortened or reversed. This is done in order to:

- a** Raise the mean airway pressure without raising peak airway pressure;

- b Allow more time for gas to flow in (e.g. when there is airway resistance) or to reach slow-filling lung units; or
- c Through these mechanisms, allow lung areas to be 'recruited'; or
- d Allow time for gas exchange to occur.

However, when the ratios are reversed there is less time to breathe out, so one must guard against 'gas trapping'.

Which mode of ventilation is preferred depends less on evidence and more on the patient and the ICU. In patients with severe respiratory failure, a pressure controlled mode is usually preferred, precisely controlling pressure while manipulating the time spent in inspiration relative to expiration – but by no means do all Intensivists agree on this!

## 13 Typical ventilator settings

*For an 'average adult', the following make sensible 'baseline settings' for mandatory ventilation:*

- Positive End Expiratory Pressure (PEEP): 5 cmH<sub>2</sub>O. (In severe asthma, perhaps 'ZEEP' or zero PEEP, to start with. In pulmonary oedema/ ARDS, much higher start at 8-10 cmH<sub>2</sub>O);
- Respiratory Rate: 14-16 per minute;
- Tidal volume: 6-8 mL/kg (based on ideal body weight) for normal lungs;
- I:E ratio: 1:2;
- FiO<sub>2</sub>: start high, and reduce depending on monitored SaO<sub>2</sub>. In a severely hypoxic patient, start with 100% to be safe.

'Special' settings might be needed in patients with ARDS, asthma, and COPD – see later chapters.

### ***High frequency oscillatory ventilation (HFOV)***

HFOV is a type of artificial ventilation in which a piston periodically compresses a constant inspiratory gas to generate oscillatory pressure waveforms with a certain amplitude (delta P) at frequencies between 3-10 Hz and sub-dead space V<sub>T</sub> of 1-4 mL/Kg body weight.

**The HFOV parameters which are usually mentioned are as follows:**

**Bias Flow:** this is the rate of fresh gas entering the circuit. It facilitates CO<sub>2</sub> clearance and establishes a continuous distending pressure or mean airway pressure (mPaw);

**Frequency:** the rate of pressure oscillations in Hertz (1 Hz = 60 breaths per minute);

**Continuing distending pressure or mean airway pressure (mPaw):** determines mean lung volume, lung recruitment and therefore oxygenation;

**Oscillatory pressure amplitude (delta P)** describes the 'peak to peak' around the mPaw (usual range 60-90 cmH<sub>2</sub>O). Delta P is controlled by the power setting measured in arbitrary units ranging from 1 to 10. The relationship between power and delta P is not fixed but depends on the mechanical characteristics of the respiratory system;

**Inspiratory time:** percentage of the respiratory cycle allocated to inspiration – routinely set at 33% to (I:E ratio 1:2).

HFOV is now mainly used as a rescue treatment in hypoxemic respiratory failure in patient unsuitable for extracorporeal support and failed conventional ventilation in prone position.

**Indications for HFOV**

Acute respiratory distress syndrome (ARDS), with the following severity criteria:

FiO<sub>2</sub> >0.7 and/or SaO<sub>2</sub> <88% on conventional mechanical ventilation (CMV) with positive end-expiratory pressure (PEEP) >15 cmH<sub>2</sub>O, or

Plateau pressures >30 cmH<sub>2</sub>O, or

Mean airway pressure (mPAW) >24 cmH<sub>2</sub>O

Pulmonary contusions

Bronchopleural fistulas (BPF) and massive air leaks

Bronchial injury

**How to set up a patient on HFOV  
Initial settings**

- 1 FiO<sub>2</sub> of 1.0;
- 2 An initial oscillatory frequency of 4-6 Hz;
- 3 I:E of 33%;
- 4 Bias flow set of 30-60 L/min;
- 5 A mPAW of 3 cmH<sub>2</sub>O above the mPAW used during CMV prior to HFOV;
- 6 DeltaP generally around 80-90 cmH<sub>2</sub>O. (Reduce in severe, proximal air-leaks)



One of the unique aspects of HFOV is that it can control oxygenation and ventilation (CO<sub>2</sub> removal) separately:

#### **Management of Oxygenation**

Oxygenation is controlled via FiO<sub>2</sub> and mPaw;

Increasing mPaw will increase aerated lung volume (recruitment);

#### **Management of Ventilation (CO<sub>2</sub> removal)**

*Size of ETT* (the larger the internal diameter the higher the alveolar pressure transmission, the larger the V<sub>T</sub>).

*Delta P*: the larger Delta P, the higher the V<sub>T</sub>.

*Frequency*: The lower the Hz the larger the V<sub>T</sub>. Ventilation using larger Delta P and higher VT seem more protective than using setting with smaller Delta P and lower Hz.

High frequencies affect alveolar recruitment as higher gas velocities generate pressures that can exceed the thresholds for alveolar opening.

Ventilation efficiency (Q) is more dependent on V<sub>T</sub> and is expressed as:  $Q = f V_T^2$ .

The goal of HFOV is to achieve adequate CO<sub>2</sub> elimination, with the highest frequency tolerated.

#### **Avoid HFOV if:**

- Significant hemodynamic instability;
- Intractable hypotension;
- Intractable respiratory acidosis;
- Unstable air leak with multiple recurrences.

#### **Weaning the patient from HFO**

Consider taking the patient off HFOV when mPAW <22 cmH<sub>2</sub>O and FiO<sub>2</sub> of 0.4 for 24 hours

## 14 Care of the ventilated patient

### Analgesia, sedation and paralysis

Understand that sedation, analgesia and paralysis are NOT the same thing.

Whilst some analgesics and anxiolytics can sedate (and vice versa), the primary action and intent of use differs with each class of drug.

Pain is common in the ICU whether due to the underlying condition, or from procedures to which the patient is being subjected. The same is also true of simple distress (e.g. tolerating an endotracheal tube) or anxiety. Sedation, anxiolysis and analgesia are often thus needed. Numerous different agents may be used, some have the advantage of blunting the respiratory drive, and thus improve ventilator synchrony. In extreme situations where effective ventilation is difficult, paralysis with neuromuscular blocking agents may also be necessary. This does *not* prevent distress (it can cause it if the patient is aware) but stops the outward manifestations being evident. All paralysed patients must thus be sedated unless already unconscious.

Whilst use of sedative and analgesic agents is very common and necessary, there are marked downsides to their use:

- a Depression of cardiac function (directly, or through loss of endogenous sympathetic drive), and vasodilation which may cause hypotension;

- b Respiratory depression (a double edged sword – see above);
- c Some metabolites, such as those of midazolam, are actually excitatory and may increase agitation, contributing to the development of delirium, thus potentially increasing the need for more sedation;
- d Many agents (or their metabolites) accumulate especially in the presence of hepatic or renal dysfunction. Low protein states, loss of body mass and drug interactions can all contribute to this. Drug clearance in renal replacement therapy is also variable.

Use of these agents can thus prolong the duration of ventilation and intensive care stay. There is thus a drive to use *minimise the amounts of these agents given*. Thus, many ICUs are:

- 1 Moving to opioid-based sedation, and avoiding benzodiazepine use;
- 2 Moving away from routinely using sedative/analgesic infusions of midazolam/morphine, to the use of intermittent small boluses;
- 3 Introducing 'sedation holds' (often combined with spontaneous breathing trials); i.e. turning off all sedatives and analgesics first thing in the morning in appropriate patients, and allowing them to begin to 'wake up'. If this is rapid and complete, the infusion may be restarted at the same rate. If slow, then the infusion can be restarted at a lower rate when the patient is awake enough;
- 4 Monitoring sedation depth more closely.

In order to minimise the amount of sedation used, scores have been developed to assess levels of sedation (🔗 [Table 3, opposite](#)). Ideally, sedation should result in a patient who is either awake but co-operative or who is lightly sedated but responding to commands (i.e. a score 0 to -2).

### Choice of agents (🔗 [Tables 4 and 5 pages 118-121](#))

Often, an opioid is used alone or in combination with a hypnotic agent. There is a move away from the routine use of benzodiazepines, which may lengthen ventilation duration, and increase the incidence of delirium.

### Neuromuscular blockers (🔗 [Table 6, page 122](#))

If effective mechanical ventilation is difficult (e.g. due to poor ventilator synchrony or mechanical problems such as a large flail segment), muscle paralysis with a neuromuscular blocker may be combined with mandatory ventilation. This is especially true where permissive hypercapnia is practiced – often in combination with altered I:E ratios or slow rates of ventilation. Several drugs are available to provide neuromuscular blockade, 🔗 [Table 6](#), but the most commonly used are rocuronium as a bolus, or atracurium as an infusion. Patients who are to be paralysed **MUST** be adequately sedated, as paralysis without sedation leads to ‘awareness’ and significant psychological morbidity. Sedation is difficult to assess in patients who are paralysed as sedation scores cannot be used – some ICUs now use a Bispectral Index Monitor.

Richmond Agitation Sedation Scale (RASS)			
Score	Term	Description	Stimulation
+4	Combative	Overtly combative, violent, immediate danger to staff	
+3	Very agitated	Pulls or removes tube(s) or catheter(s); aggressive	
+2	Agitated	Frequent non-purposeful movement, fights ventilator	
+1	Restless	Anxious but movements not aggressive vigorous	
0	Alert and calm		
-1	Drowsy	Not fully alert, but has sustained awakening (eye-opening/eye contact) to <b>voice (≥10 seconds)</b>	Verbal Stimulation
-2	Light sedation	Briefly awakens with eye contact to <b>voice (&lt;10 seconds)</b>	Verbal Stimulation
-3	Moderate sedation	Movement or eye opening to <b>voice (but no eye contact)</b>	Verbal Stimulation
-4	Deep sedation	No response to voice, but movement or eye opening to <b>physical</b> stimulation	Physical Stimulation
-5	Unarousable	No response to <b>voice or physical</b> stimulation	Physical Stimulation

Table 4 Characteristics of analgesic agents

Analgesia							
Drug	Class	Bolus dose	Peak effect	Infusion	Metabolism	Advantages	Disadvantages
Morphine	Opioid	2-10 mg IV	10-15 minutes	1-5 mg/h	Hepatic but active metabolite renally excreted	• Cheap	• Accumulates in renal failure • Significant respiratory depression
Fentanyl	Opioid	50-200 µg IV	3-4 minutes	50-350 mcg/hr	Hepatic	• Doesn't accumulate in renal failure • Rapid offset after bolus	• Respiratory depression • Context sensitive half life with infusion
Alfentanil	Opioid	250-500 mcg IV	90 seconds	0.5-3 mg/hr	Hepatic	• Safe in renal failure • Rapid wake up	• Respiratory depression
Remifentanyl	Opioid	5-10 mcg	60 seconds	0.5-10 mcg/kg/hr	Tissue esterases	• Safe in renal and hepatic failure	• Hypotension and bradycardia with boluses

Table 5 Characteristics of sedative agents

Sedatives							
Drug	Class	Bolus dose	Peak effect	Infusion	Metabolism	Advantages	Disadvantages
Propofol	—	1-3 mg/kg	60 seconds	0.5-3 mg/kg/hr	Hepatic and lung	<ul style="list-style-type: none"> <li>• Relatively rapid wake up time</li> </ul>	<ul style="list-style-type: none"> <li>• Causes vasodilation and is negatively inotropic</li> <li>• Apnoea with large bolus doses</li> <li>• May cause hypertriglyceridaemia with high doses</li> <li>• High calorific value unless 2% formulation is used</li> </ul>
Midazolam	Benzodiazepine	2-8 mg	3 minutes	2-5 mg/hr	Hepatic with renal excretion of active metabolites	<ul style="list-style-type: none"> <li>• Amnesic</li> <li>• Less negatively inotropic and vasodilatory than Propofol</li> </ul>	<ul style="list-style-type: none"> <li>• Accumulation in hepatic and renal failure</li> <li>• Strongly associated with delirium</li> </ul>
Lorazepam	Benzodiazepine	1-4 mg	15 minutes	0.5-10 mg/hr	Hepatic	<ul style="list-style-type: none"> <li>• No accumulation in renal failure</li> </ul>	<ul style="list-style-type: none"> <li>• Risk of delirium</li> </ul>
Ketamine	NMDA antagonist	1-2 mg/kg IV; 5 mg/kg IM	1-2 minutes IV 2-8 minutes IM	2-5 mg/hr	Hepatic with renal excretion of active metabolites	<ul style="list-style-type: none"> <li>• Causes bronchodilation</li> <li>• Sympathetic stimulant so cardiovascularly stable</li> </ul>	<ul style="list-style-type: none"> <li>• May cause hallucinations</li> <li>• Contraindicated in ischaemic heart disease and raised intracranial pressure</li> </ul>
Haloperidol	Dopamine antagonist	5 mg IV or IM	20 minutes	10 mg/hr	Hepatic	<ul style="list-style-type: none"> <li>• No respiratory depression</li> </ul>	<ul style="list-style-type: none"> <li>• Causes long QT</li> <li>• Long onset of action</li> </ul>
Clonidine	Alpha 2 agonist	1-5 µg/kg	5-10 minutes			<ul style="list-style-type: none"> <li>• Cheap</li> <li>• Protects against delirium</li> </ul>	<ul style="list-style-type: none"> <li>• Causes hypotension</li> <li>• Constipation</li> </ul>
Dexmedetomidine	Selective Alpha 2 agonist	1 µg/Kg over 10 min	distribution half-life (t <sub>1/2</sub> ) 6 minutes; terminal elimination t <sub>1/2</sub> 2 hours	0.2-0.8 µg/Kg/h	Hepatic – complete Biotransformation	<ul style="list-style-type: none"> <li>• No active metabolites</li> <li>• Lowest risk of delirium of any sedative</li> </ul>	<ul style="list-style-type: none"> <li>• Bradycardia, hypotension</li> </ul>

Table 6 Characteristics of neuromuscular blockers

Neuromuscular blockers							
Drug	Type	Bolus dose	Duration	Infusion	Metabolism	Advantages	Disadvantages
Suxamethonium	Depolarising	1-2 mg/kg	onset 30-60 seconds duration 5 minutes	—	Plasma Cholinesterases	<ul style="list-style-type: none"> <li>• Rapid onset of action</li> <li>• Short duration</li> </ul>	<ul style="list-style-type: none"> <li>• May precipitate hyperkalaemia</li> <li>• Raises intracranial and intraocular pressures</li> <li>• Causes muscular pain from fasciculations</li> <li>• May cause prolonged paralysis in susceptible patients</li> </ul>
Atracurium	Non-depolarising	0.3-0.6 mg/kg	20-40 minutes	5-25 mcg/kg/min	Hoffman degradation	<ul style="list-style-type: none"> <li>• Predictable effect</li> <li>• Safe in hepatic and renal impairment</li> </ul>	<ul style="list-style-type: none"> <li>• Can occasionally cause histamine release and anaphylactoid reactions</li> </ul>
Vecuronium	Non-depolarising	0.08-0.1 mg/kg	15-30 minutes	0.8-1.4mcg/kg/min	Excreted in bile and urine	<ul style="list-style-type: none"> <li>• Doesn't cause histamine release</li> </ul>	<ul style="list-style-type: none"> <li>• Action prolonged in renal impairment</li> </ul>
Rocuronium	Non-depolarising	3-0.45 mg/kg 0.6 mg/kg 0.9 mg/kg	15-25 minutes 30-40 minutes 50 minutes	300-600 mcg/kg/hr	Hepatic uptake and biliary excretion	<ul style="list-style-type: none"> <li>• Doesn't cause histamine release</li> <li>• Safe in renal failure</li> </ul>	

**Pressure area care**

Ventilated patients, especially those who are sedated, lose the ability to reposition themselves placing them at risk of developing pressure sores. These most commonly develop where skin covers a bony prominence. Preventative measures include turning and repositioning the patient every 2-4 hours, the use of pressure relieving beds and mattresses, and frequent inspection of pressure areas with early intervention when skin damage is found.

**Eye care**

Dry eyes, exposure keratopathy and corneal abrasions are frequently encountered in intensive care patients due to the loss of normal protective mechanisms such as the ability to close the eyes or blink. These complications are best prevented with the use of aqueous tears or eye lubricants to keep the corneas moist and hydrogel pads or tapes to keep the eyes closed. Corneal oedema can be prevented by keeping the patient's head elevated.

**Mouth care**

Regularly teeth brushing (12 hourly), keeping the mouth moist and removal of debris and saliva are necessary to prevent oral ulceration and gingivitis. The use of oral antiseptics such as 1% chlorhexidine gel are associated with a reduction in rates of ventilator-associated pneumonia (VAP) and now form part of the Department of Health VAP prevention guidance ([📄 page 128](#)).

**Airway toilet**

As the cough reflex is either lost or attenuated in intubated and sedated patients airway secretions can pool as they are not expectorated in the usual way. It is important to remove these to prevent infection and airway obstruction and to allow optimal ventilation. This is achieved with a combination of chest physiotherapy and airway suction. Suction is performed using PVC suction catheters that pass down ETT or tracheostomy tubes. These can be kept 'inline' with the ventilator tubing so that they do not have to be disconnected and reconnected each time the airway needs suctioning. Sputum traps can be attached to the suction apparatus to allow tracheal aspirate samples to be collected relatively cleanly.

**Stress ulcer prevention**

Ventilated patients are at risk of gastric and duodenal stress ulceration although rates of bleeding are very low nowadays (<0.5%). Prevention is best by ensuring adequate tissue perfusion (i.e. blood flow/fluid resuscitation) and enteral nutrition – which encourages mucosal perfusion. If this cannot be done, H<sub>2</sub> antagonists or proton-pump inhibitors should be prescribed to suppress gastric acid production.

## 15 Hospital acquired pneumonia (HAP)

HAP is defined as the development of new radiographic changes with evidence of infection after >72 hours of being in hospital. HAP is one of the leading cause of death from hospital acquired infection and often occurs outside of the ICU. Pulmonary aspiration is perhaps the commonest cause. The upper airways become colonised with gram negative bacteria (75% of people within 48 hours), the situation worsened by broad spectrum antibiotics and a change in gastric pH meaning the upper gastrointestinal (GI) tract is no longer sterile. Aspiration risk is increased by reduced conscious level (e.g. drug overdose/seizure), dysphagia, upper GI conditions affecting sphincter closure (e.g. nasogastric [NG] tube in situ) and causes of increased reflux (e.g. high volume NG feed). Other risk factors include chronic lung disease or other co-morbidities (especially diabetes), age, steroids and cytotoxic medications.

## 16 Ventilator-associated pneumonia (VAP)

VAP is defined as pneumonia occurring in a mechanically ventilated patient after 48 hours of endotracheal intubation, and affects 5-25% intubated patients. Clinically, inflammatory markers may rise, fever may develop or increase, and oxygenation may worsen, with the development of new radiographic findings. It is associated with prolonged mechanical ventilation and (as an independent factor) with excess mortality. Some ICUs use VAP rates, especially late-onset VAP, as a quality indicator of the care provided to intubated critically ill patients.

### Time of onset is an important epidemiological variable

**Early-onset VAP** occurs within the first 5 days of mechanical ventilation, has a better prognosis and is more likely caused by community microorganisms (*Streptococcus pneumoniae*, *Haemophilus influenzae*, methicillin-sensitive *Staphylococcus aureus* and antibiotic-sensitive enteric Gram-negative bacilli).

**Late-onset VAP** happens after day 5 and is more frequently due to multidrug-resistant pathogens such as *Pseudomonas aeruginosa*, resistant *Klebsiella pneumoniae*, *Acinetobacter baumannii* or methicillin-resistant *S. aureus*, with higher mortality rates.



The incidence of VAP can be reduced by using a ‘care bundle’. A care bundle is a small, simple set of scientifically grounded elements (generally 3-5) that, when implemented together, improve outcome.

### Elements of the care process

*Department of Health 2011 VAP bundle include six elements*

The 6 actions outlined below are the recommended good practice:

- 1 **Elevation of the head of the bed:** The head of the bed is elevated to 30-45° (unless contraindicated);
- 2 **Sedation level assessment:** Unless the patient is awake and comfortable, sedation is reduced/held for assessment at least daily (unless contraindicated);
- 3 **Oral hygiene:** The mouth is cleaned with Chlorhexidine Gluconate ( $\geq 1-2\%$  gel or liquid) 6 hourly (as Chlorhexidine can be inactivated by toothpaste, a gap of at least 2 hours should be left between its application and tooth brushing). Teeth are brushed 12 hourly with standard toothpaste;
- 4 **Subglottic aspiration:** A tracheal tube (endotracheal or tracheostomy) which has a subglottic secretion drainage port is used if the patient is expected to be intubated for >72 hrs. Secretions are aspirated via the subglottic secretion port 1-2 hourly.
- 5 **Tracheal tube cuff pressure:** Cuff pressure is measured 4 hourly, maintained between 20-30 cmH<sub>2</sub>O (or 2 cmH<sub>2</sub>O above peak inspiratory pressure) and recorded on the ICU chart;

- 6 **Stress ulcer prophylaxis:** Stress ulcer prophylaxis is prescribed only to high-risk patients according to locally developed guidelines. Prophylaxis is reviewed daily.

Other interventions (such as selective decontamination of digestive tract [SDD]) remain controversial and lack definitive proof of benefit.

Treatment of VAP can be difficult due to the development of resistance which is increased by prolonged ventilation and previous broad spectrum antibiotic use; refer to your local guidelines or discuss with your microbiologist.

## 17 Ventilator troubleshooting

### Basic rules

The new doctor often panics when ‘things go wrong’ in a mechanically ventilated patient. Generally, a calm logical and systematic approach solves most problems, and ‘basic algorithms’ are learned with time. To speed things up, we will give you our views here. But basic rules still apply:

**Remember (assume the problem is with the patient not the machine!):**

- 1 **Airway** (Is the tracheostomy or ET tube displaced or blocked? Is the ventilator disconnected?).
- 2 **Breathing** (Is there a [tension/simple] pneumothorax? Sputum plug in a bronchus? Loss of effort by the patient who is breathing on pressure support? Loss of ‘drive’ from the machine for some reason?).
- 3 **Circulation** (Has loss of pulmonary blood flow affected on gas exchange? Has a respiratory event caused a circulatory change? Has a ‘septic storm’ affected both blood pressure and ventilation?).

**And, as for every emergency,**

- 4 **Get help early if unsure.** Don’t be proud.

Most ‘trouble’ is thus diagnosed by rapid clinical examination, with CXR confirmation. But if the patient is dying, don’t wait for the x-ray. ACT!

Equally, most trouble is managed with simple clinical manoeuvres: bagging the patient yourself, or even removing an ETT/tracheostomy and resorting to bag-and-mask ventilation on 100% O<sub>2</sub> can often get you out of trouble.

### Desaturation and hypoxia

Desaturation is generally caused by a sudden increase in V:Q mismatch (👉 pages 16, 22). While some areas of ventilated lung may no longer be perfused (e.g. secondary to a PE), most commonly the problem is that perfused areas are suddenly no longer ventilated. Small drops in PaO<sub>2</sub> are often managed by increasing inspired fraction of O<sub>2</sub> (FiO<sub>2</sub>). However, sudden bigger and sustained falls in oxygenation need prompt diagnosis and intervention.

#### Action

- 1 Attend the patient promptly.
- 2 Increase the FiO<sub>2</sub> appropriately (to 100% O<sub>2</sub> if necessary; remember this is somewhat ‘cosmetic’, seek and treat the cause).
- 3 Is the patient ventilating? Check for chest wall movement (and its synergy) visually and manually while looking at the ventilator (for low tidal volumes/alarms from high pressures).

- 4 If inadequate ventilation, disconnect from the ventilator, and bag manually on 100% O<sub>2</sub>. Then ascertain which of the possible causes seems most likely, and treat:
- a Blocked or displaced tracheostomy or endotracheal tube will make bagging hard. Can a suction catheter be passed? If no time, or in doubt, extubate and revert to bag-and-mask ventilation (covering the trachi hole if necessary).
  - b Tension pneumothorax will make 'bagging' hard. Simple pneumothorax may remain easy. If tension clinically present, perform a needle thoracocentesis. NB that, in ARDS, 'loculated pneumothoraces' often occur, and can be multiple. Thus, a chest drain can still be bubbling well, which doesn't exclude the occurrence of another pneumothorax on the same side! Look for anterior pneumothorax (is one lung – the affected one – 'lighter' than the other on CXR? Is there a deep concave-upward lung shadow extending beyond the diaphragm? If in doubt, ask for a lateral chest XR 'a lateral shoot through'. Radiographers hate doing this, but it is sometimes the only way of getting a safe fast diagnosis. If stability is restored you may need a CT).
  - c Major sputum plug occluding one or both main bronchi / a large segmental bronchus. Bagging (with or without 5-10ml saline squirted down the ETT) with chest physio (you and the nurse will work as a team) may clear it. Once 'safe', bronchoscopy might be needed);

- d Endobronchial intubation. ETT advanced too far and sitting in the right main bronchus;
- e Massive acute pulmonary alveolar 'flooding' (severe ARDS, pulmonary haemorrhage, or pulmonary oedema). This is usually evident on seeing 'froth' coming up the ETT). If 'ARDS', then reconnecting to the ventilator, increasing PEEP, and managing appropriately ([page 176](#)) is best. If cardiogenic origin, then appropriate medications (IV nitrates, removing fluid if on a haemofilter) should be instigated.

In general, 'bagging up' restores saturations – and going back on the ventilator with a higher PEEP can limit further alveolar collapse/plugging and improve compliance ([page 178](#)), while an urgent CXR is organised to help ascertain a cause. As a rule of thumb, start with a level of PEEP that is roughly 1/5th of the FiO<sub>2</sub> required maintaining the PaO<sub>2</sub> at 8 kPa. ARDSNet provides a PEEP/FiO<sub>2</sub> scale that can be used at the beginning of mechanical ventilation.

### Recruitment manoeuvres

PEEP acts like a stent for the distal airspaces and counterbalances the compressive force generated by the elastic recoil of the lungs and the chest wall/abdomen. In addition to preventing atelectasis, PEEP can also open collapsed alveoli and reverse atelectasis. PEEP can thus be used in specific *recruitment manoeuvres* to bring areas of atelectasis/alveolar collapse 'back into play' – allowing once-collapsed alveoli to take part in gas exchange.

Multiple methods have been described – including ‘holding’ inspiratory pressure at 30-40 cmH<sub>2</sub>O pressure for 30-40 seconds. During recruitment the high pressure may cause haemodynamic compromise. This should resolve on manoeuvre cessation. Once lung has been recruited, PEEP needs to be applied to keep the recruited tissue open: maintain an elevated PEEP, and avoid ventilator disconnections (such as might occur for routine delivery of a nebuliser).

The effect of PEEP on lung recruitment can be monitored with PaO<sub>2</sub>/FiO<sub>2</sub> ratio, which is a measure of the efficiency of O<sub>2</sub> exchange across the lungs. If PEEP has a favourable effect and converts areas of atelectasis to functional alveolar-capillary units, there will be an increase in the PaO<sub>2</sub>/FiO<sub>2</sub> ratio (improves oxygenation). PEEP has the same influence on the determinants of cardiac performance as positive-pressure ventilation, but the ability to decrease ventricular preload is more prominent with PEEP.

### Climbing PaCO<sub>2</sub> – Hypercapnia

CO<sub>2</sub> clearance will fall if effective alveolar minute volume falls. This can occur as a result of:

- a Fewer breaths being taken/delivered;
- b Smaller breaths being taken/delivered;
- c Anatomical or physiological dead space increasing ([page 15](#)).

A rise in PaCO<sub>2</sub> can be detrimental: intracranial pressure can rise, alveolar O<sub>2</sub> can be ‘diluted’ by CO<sub>2</sub> such that alveolar (and thus arterial) O<sub>2</sub> levels start to fall, and the patient may become obtunded. However, with a secure airway, being

obtunded is less of a problem. In addition, there are few data that modest (or even quite severe) levels of respiratory acidosis are directly harmful in the critically ill intubated patient. Indeed, trying to ‘drive the lungs’ to clear CO<sub>2</sub> can be far more detrimental ([page 170](#)). Stable levels of CO<sub>2</sub> giving a pH of 7.25 or even less are thus often accepted. With time, (normal) renal function will compensate by retaining bicarbonate, restoring pH to nearer normal ([page 29](#)).

### *The commonest situation by far is that tidal volumes fall during pressure controlled ventilation.*

Here, one needs to follow the analytical process shown for hypoxia ([page 131](#)): is the ventilator working? Is the ETT/tracheostomy tube wholly/partially blocked? If you are on a pressure-controlled mode, has compliance fallen, thus reducing tidal volumes? Is there a blocked bronchus? Is there a pneumothorax? A tension pneumothorax? Or is the problem tachypnoea driven ([page 137](#)). Diagnose and treat appropriately, and tidal volumes will be restored. Once you have ‘done the best you can’ to get the tidal volume you need, then you may need still to increase the respiratory rate in sensible stages (with repeat blood gases 20 minutes after each change, or with end-tidal CO<sub>2</sub> monitoring if concerned). There are, however, some special situations in which this may not be ideal, such as in severe asthma. Here, a slow rate (+/-low tidal volumes) is the mainstay of therapy. Similarly, COPD can be difficult to manage. Imagine that tidal volumes are low. Acidaemia occurs as PaCO<sub>2</sub> rises:

- 1 You increase respiratory rate from 24 to 28.
- 2 Things get worse.
- 3 You increase the rate again.

- 4 Worse again.
- 5 What is to be done?

Very often, the problem here is ‘breath stacking’, also known as ‘gas trapping’ or ‘dynamic hyperinflation’, which results from premature termination of passive exhalation before the lung volume reaches functional residual capacity: there isn’t enough time for the air pushed ‘in’ to get ‘out’. *Intrinsic PEEP* (PEEPi) thus rises which reduces pulmonary blood flow and increases dead space with a result that much of the delivered tidal volume does not contribute to CO<sub>2</sub> clearance. This can be due to short expiratory phase (inverse ratio ventilation), a slow expiratory flow (asthma) or both.

Oddly, the first approach on arriving is sometimes to **slow** the rate down. Then look at the ventilator graphics. If there is trapping (i.e. flow doesn’t get to zero in expiration), you might disconnect the ventilator and press on the chest – hearing a long slow ‘sigh’ as gas escapes. On reconnection, the tidal volumes are often restored. Adjusting the rate (and, in PCV, the time of expiration relative to inspiration) such that gas trapping is minimised is then the key. Note, however, that you may have to accept a slightly raised PaCO<sub>2</sub>. Finally, if intrinsic or ‘auto’ PEEP is very high, you can sometimes overcome this (and allow release of gas trapping without disconnection) by raising the PEEP to 80-90% of autoPEEP (🔗 [page 144](#)). For example if autoPEEP is 10 cmH<sub>2</sub>O, applying an extrinsic PEEP of 8 cmH<sub>2</sub>O may improve alveolar emptying. Routine application of this methodology needs careful assessment of autoPEEP and needs frequent adjustments as this is dynamic phenomenon which if left unchecked can lead to severe haemodynamic compromise. These situations are difficult to manage and require senior help!

## Tachypnoea

Treatment of tachypnoea in patients on pressure support modes of ventilation (and whether treatment is warranted) depends on the cause (🔗 [Table 7, below](#)).

Table 7	
Causes of tachypnoea	
<b>Ventilation Problems</b>	Inadequate tidal volumes (inc poor synchronisation) Sensitive breath trigger – inappropriate triggering e.g. shivering
<b>Patient Problems</b>	Hypoxia Metabolic acidosis Respiratory pathology Discomfort (is the catheter blocked?), pain, anguish Delirium, hallucination, new sepsis, pulmonary oedema

Treatment should be directed at the cause. Management of low tidal volumes is largely covered above (🔗 [page 131](#)). However, on occasion, rapid respiratory rates (perhaps due to anxiety) can cause gas trapping (or a fall in effective alveolar ventilation) in those with lung disease, and thus drive a fall in tidal volume. Here, assessing response to bolus analgesia/anxiolytic can be both diagnostic and therapeutic.

## Patient-ventilator asynchrony

This refers to a situation where the ventilator is trying to deliver a breath when the patient is trying to breathe out – and/or vice versa.

Patient-ventilator interaction can be described as the relationship between 2 respiratory pumps:

- 1 the patient's pulmonary system, which is controlled by the neuromuscular system and influenced by the mechanical characteristics of the lungs and thorax, and
- 2 the ventilator, which is controlled by the ventilator settings and the function of the flow valve.

When the 2 pumps function in synchrony, every phase of the breath is perfectly matched. Anything that upsets the harmony between the 2 pumps results in asynchrony and causes patient discomfort and unnecessarily increases work of breathing.

**Asynchrony** occurs when there is a discrepancy between patient and ventilator in one or more of the breathing phases:

- 1 **The trigger mechanism** (i.e. initiation of the inspiration), which is influenced by the trigger – sensitivity setting, patient effort, and valve responsiveness (🔗 Figs 24, 25).
- 2 **The inspiratory-flow phase.** During both volume-controlled and pressure-controlled ventilation, the patient's flow demand should be carefully evaluated, using the pressure and flow waveforms.
- 3 **Breath termination** (i.e. the end of the inspiration). Ideally, the ventilator terminates inspiratory flow in synchrony with the patient's neural timing, but frequently the ventilator terminates inspiration either early or late, relative to the patient's neural timing. During volume-controlled ventilation we can adjust variables that affect inspiratory time (e.g., peak flow, tidal volume). During pressure-controlled or pressure-

support ventilation we can adjust variables that affect when the inspiration terminates (e.g., inspiratory time, expiratory sensitivity).

- 4 **Expiratory phase.** Presence of auto-PEEP (🔗 page 144) can lead to difficulty in triggering the ventilator. In *pressure support* or *synchronised IMV* modes, this is often because the trigger sensitivity (🔗 page 105) needs adjusting. Too low, and the patient 'hauls' at the ventilator, only generating enough pressure or flow to trigger the breath at the last minute – when the patient is about to breathe out. This can also be a problem in those with marked respiratory muscle weakness/small lungs and tidal volumes, significant airway obstruction (prevents transmission of airway pressures to the ETT) or restriction (makes tidal volumes small). Too *high*, and the smallest shudder/ shiver/movement triggers a breath, which isn't synchronised with the *real* breath effort. Ventilator dysynchrony is thus much more common in those with low tidal volumes and/or high respiratory rate – and is sometimes resolved by administration of drugs to lower that rate (for instance, in treating anxiety/tube intolerance/pain). If gas exchange is impaired, and the problem cannot be resolved, deeper sedation is usually preferred, with a move to mandatory ventilation (with or without neuromuscular blockade) if needed.

Other modes of ventilation can be problematic, with mandatory modes sometimes less well tolerated than SIMV/PS. Similarly an I:E ratio closer to that of normal breathing (1:2) is often better tolerated than 'reverse I:E' ratios (🔗 page 107).

The mode of breath triggering (🔗 [page 105](#)) may also be a problem: if insufficient negative pressure can be generated to trigger breaths, trials of flow-triggering are appropriate. A high level of intrinsic PEEP (🔗 [page 145](#)) is a common cause of dysynchrony, as it prevents breaths being triggered. External PEEP will improve triggering in this situation (🔗 [Fig 24](#)). Alternatively, the ventilator can deliver untriggered breaths because of low set trigger or circuit leaks (🔗 [Fig 25, page 142](#)).

### High airway pressures

Ventilators measure airway pressure. The airway pressure arising from delivery of breath in a passive patient is defined by the simplified equation of motion for the respiratory system:

$$\text{Airway Pressure} = (\text{Flow} \times \text{Resistance}) + (\text{Tidal volume} \times 1/\text{compliance}) + \text{PEEP}_{\text{Total}}$$

As airway resistance is low in the normal lung, airway pressure approximates to alveolar pressure. High pressures can damage lungs and worsen acute lung injury/ARDS (🔗 [page 176](#)), cause pneumothoraces, and can have impacts on the circulation (🔗 [page 71](#)). Ideally, airway pressures are kept below 30 cmH<sub>2</sub>O. However, sometimes high pressures are seen during volume-controlled ventilation (🔗 [page 95](#)), either from the outset, or develop over time (sometimes rapidly).

In pressure controlled ventilation, peak pressure will be roughly the sum of the PEEP and the set inspiratory pressure. In volume controlled ventilation, peak pressure will depend on inspiratory flow rate, airway resistance, and lung compliance: if compliance falls (🔗 [page 96](#)) pressures will rise. Plateau pressure will depend on lung compliance, and on tidal volume.

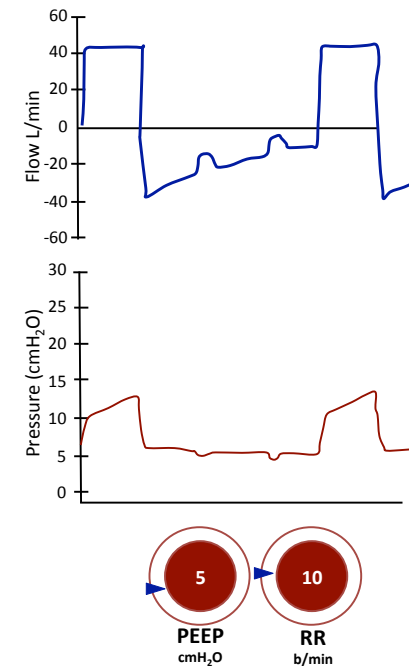

**Fig 24 Ineffective triggering**

Notice the two changes in pressure (negative deflections) and flow (positive deflections). They represent inspiratory efforts which fail to trigger the ventilator. A too high trigger level or the presence of intrinsic PEEP can cause ineffective triggering.

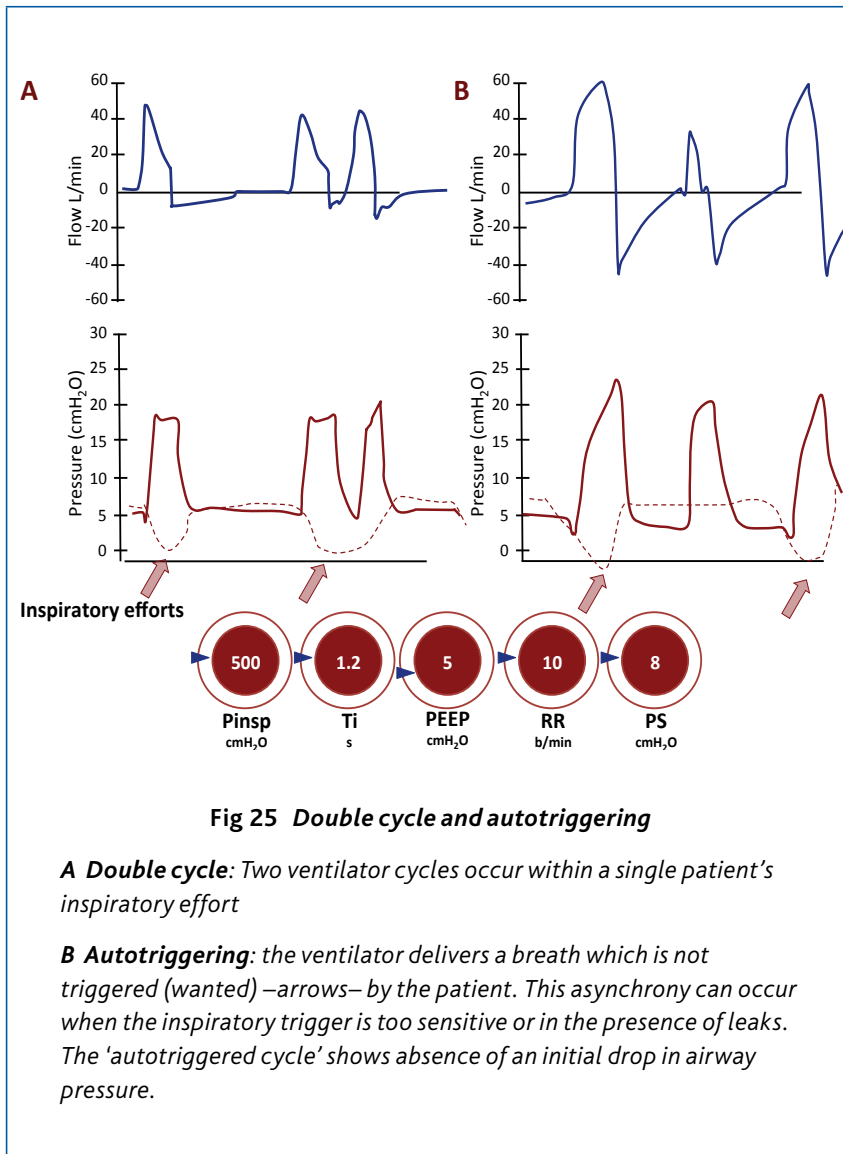

Knowledge of the pressure waveform is useful when trying to determine the cause of high airway pressures. In pressure controlled ventilation, the pressure rises to a preset peak, and then driving pressure is held. The compliant lung continues to expand, and airflow continues during this period. The inspiratory plateau pressure can be measured in apnoeic or paralysed patients by activating an inspiratory pause hold. At this point there is no flow so (from the formula above, [page 141](#)) airway pressure will equate to alveolar pressure.

- In volume-control ventilation, a *high peak airway pressure with lower plateau* suggests an increase in airway resistance – including airway obstruction. If sudden, the ETT may be blocked with secretions; the end of the ETT with a 'herniated ETT cuff'; the trachea with granulation tissue.
- A *high plateau pressure* suggests low lung compliance. There may be endobronchial intubation; pneumothorax; pulmonary oedema/haemorrhage; gas trapping; abdominal distension with diaphragm splinting; lung/ lobar collapse.

### Low tidal volumes

Insufficient tidal volume may cause inadequate minute ventilation, and thus CO<sub>2</sub> retention. The causes of reduced tidal volume (and their management) are dealt with on [page 131](#).



*One word of caution*, however: most ventilators measure tidal volume as what returns to the ventilator. Thus, if there is a leak somewhere in the return circuit, recorded tidal volume will not represent the true tidal volume which inflated the patient's lungs. A patient with a bubbling chest drain may thus be well ventilated – but the air escaping through the drain will not be recorded. Similarly, nebulisers deliver driving gas, and may augment measured tidal volumes, and moisture on the sensors cause them to miss read.

### Gas trapping/Intrinsic PEEP

Propensity to gas trapping may be identified by observing the flow/time trace, as shown in [figure 26](#): in (a), expiratory flow ceases before inspiratory flow begins, suggesting that all inspired gas is exhaled. In (b), expiratory flow continues right up until the next breath starts, suggesting that not all inspired gas is being expired. This will cause intrinsic (auto) PEEP to rise ([page 145](#)), and auto-PEEP can be measured by performing an expiratory hold in an apnoeic patient, [figure 26](#). Gas trapping can be limited by adequately treating any bronchoconstriction, ensuring sufficient expiratory time by increasing the expiratory fraction of the I:E ratio and making sure that the respiratory rate is not too high, and by ensuring the provided tidal volumes are not too great.

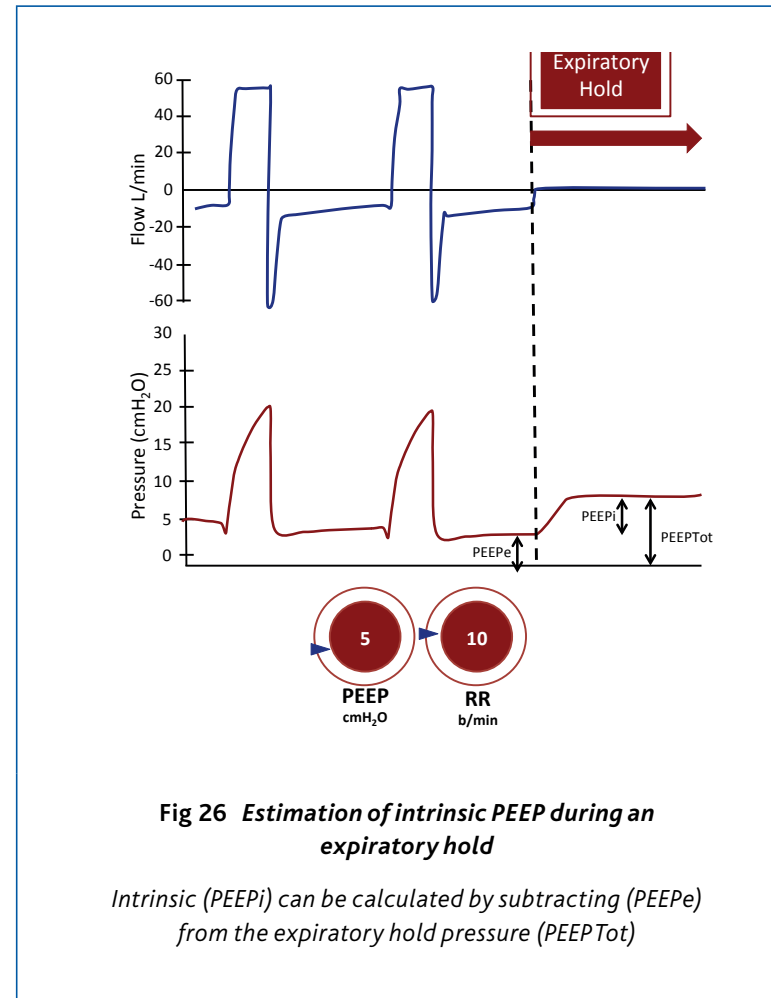

### Apnoea

Unless the ventilator fails, or the circuit occludes, apnoea shouldn't occur with mandatory modes of ventilation as the set frequency of breaths should always be delivered. Apnoea may occur in support modes of ventilation if a back

up mandatory rate is not set. Apnoea may be of cerebral origin (intrinsic brain disease, action of sedatives) or spinal/peripheral (neuromuscular) origin – paralysing agents, critical illness neuromyopathy, Guillain-Barre, or cord transection. Both hypoventilation and hyperventilation may lead to respiratory depression and apnoea. Hypoventilation leads to an accumulation of CO<sub>2</sub> and depression of consciousness. However, commonly COPD patients (who may be CO<sub>2</sub> retainers) are ‘over-ventilated’, and become alkalotic. In this state (even if PaCO<sub>2</sub> is 8 kPa!), there will be no drive to breathe. Although relatively uncommon, patients who have chronic retention of CO<sub>2</sub> may rely on hypoxia to drive respiration ([👉 page 25](#)): in these patients the provision of too much O<sub>2</sub> will depress their respiratory drive.

### Low minute ventilation

Maintaining adequate minute ventilation is essential for ensuring CO<sub>2</sub> clearance and all ventilators have a low expired minute ventilation alarm. Ventilators also measure inspired and expired tidal volumes continuously. A number of situations can result in a low minute ventilation including: changes in lung mechanics (increased resistance or reduced compliance) limiting the delivered tidal volume, disconnection, a leak in the ventilator circuit or reduced respiratory rate/apnoea in a spontaneously breathing patient. Because ventilators monitor inspired and expired tidal volumes, they will usually detect if there is a significant difference and report the presence of a leak in the circuit. As with all alarms, if the cause is not obvious and immediately treatable the first thing to do is to disconnect the patient from the ventilator and commence manual ventilation with an anaesthetic type breathing circuit.

### ***A cuff leak may cause low minute ventilation.***

You will notice the audible escape of gas from the airway. Be wary of responding to this by simply inflating the cuff. The modern endotracheal tube rarely develops a leak from the cuff. By far the most common reason for a ‘cuff leak’ is outward displacement of the endotracheal tube with the result that the cuff does not produce a seal as it is herniating above the vocal cords. Always check the position of the cuff with a laryngoscope in a patient who develops a cuff leak and be prepared to advance the tube further into the airway or to re-intubate with a longer tube if necessary.

### High pressure alarm

When the high pressure alarm is activated the ventilator will immediately stop inspiration and cycle to expiration. If the alarm continues to be activated, minute ventilation will fall rapidly therefore this alarm needs to be responded to immediately. The high pressure alarm is more likely to be activated during volume modes as the airway pressure is preset during pressure modes. A significant increase in airway resistance or reduction in compliance may result in a marked increase in airway pressure and activation of the alarm during volume ventilation. Other causes include agitation, coughing, and occlusion of the endotracheal tube. The most common cause of an apparent tube occlusion is due to the patient biting.

## 18 Adjuncts to care in ventilated patients

### Nebulisers

Nebulisers create small liquid droplets, which deliver ‘water’ (e.g. saline nebulisers to loosen secretions) or drugs (such as salbutamol in asthma) to the distal lung. They are used when metered dose inhalers (MDI) cannot offer appropriate formulation (e.g. nebulised prostacyclin), or where illness/poor technique intervenes. The latter applies to many ICU patients, who may be weak, confused, unconscious, or mechanically ventilated.

There are two predominant types of nebuliser:

**Jet nebulisers** (the most common) drive compressed gas (generally air or O<sub>2</sub>) through a chamber housing the liquid to be delivered. Aerosol production depends on gas flow rate: most require a flow 6-10 l min<sup>-1</sup> and generate particles 15-500 µm in diameter. Flow rate must be set correctly: if particles are too big they may not escape the nebuliser chamber, or may impact the back of the throat, and dribble down to be swallowed. Too small (<0.5 µm) and they may be exhaled by the patient without deposition.

**Ultrasonic nebulisers** use a vibrating piezoelectric crystal to ‘shake’ the liquid into small particles. Baffles catch larger droplets. In one small European study of ventilated patients after heart surgery, the ultrasonic system delivered more

than double the particles to the lung than a jet nebuliser, and faster. However, expense and limited availability restrict general use in the UK.

### Indications for nebulisers on ICU

#### In asthma and COPD

Salbutamol nebulisers offer beta-2 agonism. The dose (2.5-5mg) and frequency (6-hourly or back-to-back) are determined by disease severity. It is generally worthwhile to offer a ‘PRN’ prescription which the nurses can draw on. An intravenous infusion of salbutamol (2-20 micrograms/min) or aminophylline (5 mg/kg loading dose followed by 500-700 micrograms/kg/hour, adjusted according to plasma concentration) may be added. Note, however, that aminophylline has a narrow therapeutic range (side effects include tachycardia, agitation, arrhythmias and seizures); take care with those taking oral theophylline/aminophylline (avoid IV unless guided by plasma levels); macrolides such as clarithromycin/erythromycin increase plasma concentrations of theophylline, as do calcium channel blockers; and there is an increased risk of seizures co-prescribed with quinolone antibiotics. Ipratropium bromide (an anti-muscarinic) is often additionally used up to 4 times daily at a dose of 500mcg. Particular attention may need to be paid, in addition, to humidification (*see below*).

#### ARDS

Nebulised prostacyclin produces pulmonary vasodilation in the best-ventilated parts of the lung, thus improving ventilation/perfusion matching ([👉 page 16](#)). Given its short circulating half-life, it is often delivered by continuous nebuliser at a rate of 5-20 ng.kg<sup>-1</sup>.min<sup>-1</sup> without the risk of

systemic hypotension. Although oxygenation may improve in the short term, no study to date has shown evidence that it improves outcome. Being a selective pulmonary vasodilator, inhaled nitric oxide (as a gas – not nebulised!) has similar effects, and can also improve oxygenation, but once again without evidence that survival is improved. Systemic vascular side effects are largely eliminated because Hb binds to nitric oxide with high affinity. Specialist equipment is needed for its delivery.

### Factors limiting nebuliser efficacy

Only about 10% of the drug in jet nebulisers successfully deposits in the distal airways of the patient. In critically ill patients this may be lower:

- Breathing pattern and tidal volumes will affect distal distribution, whether on a ventilator or not. Thus, rapid small breaths may be less effective. Low inspiratory flow rates (30-60 L/min in adults) may improve aerosol delivery to the lower respiratory tract of mechanically ventilated patients.
- Lung disease may have an influence: high anatomical dead space will be an issue, and collapsed segments, airway stenosis and airway plugging may prevent particle distribution to the ventilated lung periphery.
- Mechanical ventilation itself limits deposition efficacy, with studies citing ranges of 0-42% for the efficiency of delivering aerosol to the lower respiratory tract<sup>2</sup>.
- Particle size: (*see above*). The degree of interference will depend on the type of nebuliser used, the drug, and the size of the ETT.

- Heated and humidified circuits: These are estimated to reduce particle deposition rates in the lung by approximately 40%<sup>3</sup>. This is partly because heating increases particle size.
- Position within circuit: Placing a nebuliser at a distance of 30 cm from the ETT rather than between the patient and the ETT, allows the ventilator tubing to act as a spacer for the aerosol to accumulate between inspiratory breaths.
- Dead volume refers to the amount of the solution trapped inside the nebuliser and tubing, which is therefore not available for inhalation. It is typically in the range of 1 to 3 ml.

**NB:** Metered dose inhalers can be given into the ventilator circuit, and some consider them to be as effective as nebulisers.

### Airway humidification/heat and moisture exchangers

*In the unventilated patient*, inhaled O<sub>2</sub> is 'dry' – and can thus desiccate upper airways (which causes cessation of ciliary function, and long-lasting loss of airway epithelium) and also thicken secretions. O<sub>2</sub> is usually humidified to prevent this – most commonly by driving it through water prior to inhalation. Heated humidification is effective, but less commonly used.

*In the mechanically ventilated patient*, gas administered through a tracheostomy/ETT bypasses the warming and moistening effects of the nose and upper airways. Most commonly, this problem is overcome by the use of 'heat and moisture exchangers' (HMEs) fitted into the

ventilator circuit. HMEs exhibit low resistance to flow, and trap the exhaled warmth and moisture of each exhaled breath. In patients with very thick secretions, improved humidification may be achieved by passing the inspired gases over a heated water bath which is placed in the inspiratory limb of the ventilator circuit. The water bath is heated to 39°C and the ventilator tubing will typically contain heating wires to ensure that the inspired gases remain warmed to 37°C in order to prevent significant condensation within the ventilator circuit. It is essential that active water bath humidification is not combined with a heat and moisture exchanger. If it is, the HME will become waterlogged and eventually obstruct.

**Nebulised saline** (👉 pages 53, 132, 148) also helps keep secretions runny or loose, such that they can be sucked out with a suction catheter. In resistant cases, saline can be irrigated (or squirted) down the ET tube and left there for many minutes: 5-10 ml/hour or so is often used until secretions loosen – and this method is often very useful in asthmatics with tenacious bronchial casts.

## 19 Weaning

Early weaning from the ventilator helps prevent episodes of ventilator-associated pneumonia (👉 page 127), loss of respiratory muscle strength, and the complications of prolonged ventilation and intubation (👉 page 160). Many methods can be used, but all involve assessing the response to a reduction in support, and an increase in patient ventilatory work. In general, therefore, a move is made from controlled mandatory ventilation to pressure support and possibly to CPAP. Some patients will wean rapidly and will tolerate a spontaneous breathing trial (SBT) immediately while in others a more gradual reduction in support is required. This wean may be continuous, or may involve extending periods of reduced support in blocks, with increased support in between (and often at night). Most require active participation from the patient, and result in increased metabolic demands.

### Example weaning plan for tracheostomy patient

**DAY 1** PS 8cmH<sub>2</sub>O 0800-2200  
 3 X 30-60min TM periods during the day  
 Cuff deflated with speaking valve  
 (👉 Fig 27, page 165)  
 PS 14cmH<sub>2</sub>O 2300-0800

**DAY 2** PS 8cmH<sub>2</sub>O 0800-2400  
4 X 2hr TM periods during the day  
Cuff deflated with speaking valve  
PS 12 cmH<sub>2</sub>O 2400-0800

**DAY 3** TM 0800-2000 with cuff deflated and speaking valve  
  
PS 8cmH<sub>2</sub>O 2000-0800

**DAY 4** TM for 24hrs with cuff deflated and speaking valve

**DAY 5** Assess for decannulation ([👉 page 166](#))

Daily progression will vary from patient to patient and length of time off ventilation needs to be assessed on an individual basis

TM = tracheostomy mask

### Assessing suitability to wean

A number of subjective and objective physiological parameters can be used for assessing readiness to wean. Patients should be assessed daily according to the following:

#### 1 Clinical assessment

- a Adequate cough
- b Absence of excessive respiratory secretions

- c Resolution of disease acute phase for which the patient was intubated

#### 2 Objective measurements

- a Clinical stability
  - i Stable haemodynamically (i.e. HR ≤140 beats/min, systolic BP 90–160 mmHg, no or minimal vasopressors)
  - ii Stable metabolic status
- b Adequate oxygenation
  - i SatO<sub>2</sub> >90% on FiO<sub>2</sub> ≤0.5 (or PaO<sub>2</sub>/FiO<sub>2</sub> ≥ 20 kPa)
  - ii PEEP ≤8 cmH<sub>2</sub>O
- c Adequate pulmonary function
  - i RR ≤35 breaths/min
  - ii Maximal inspiratory pressure ≤ -20 – -25 cmH<sub>2</sub>O
  - iii Tidal volume (TV) >5 mL/kg
  - iv Vital capacity (VC) >10 mL/kg
  - v RR/TV <105 breaths/min/L
  - vi No significant respiratory acidosis
- d Adequate mentation
- e No sedation or adequate mentation on sedation (or stable neurologic patient)

These predictors of weaning success may not necessarily all be present simultaneously; they merely form a guide to which clinical decisions can be made, rather than strict criteria for weaning. In general an afebrile, alert and haemodynamically stable patient, who is able to oxygenate while breathing 50%

O<sub>2</sub> or less with a minimum of applied PEEP, is a suitable candidate for a spontaneous breathing trial.

### Assessing suitability for extubation

Early and regular sedation holds are imperative to avoid accumulation of sedation, and to allow assessment of the suitability to be weaned. This may be combined (where appropriate) with a 'trial of spontaneous breathing' (SBT) – a test of the patient's ability to breathe without substantial ventilatory support. The patient's respiratory support is reduced for a short period of time and closely monitored during this trial. Successful extubation is predicted if the patient tolerates the spontaneous breathing trial. Large studies have demonstrated that only 13% of patients who were extubated following successful spontaneous breathing trials required reintubation. In patients extubated without spontaneous breathing trials, the failure rate was approximately 40%.

In SBTs, low-level Pressure Support ( $\leq 7$  cmH<sub>2</sub>O) or Continuous Positive Airway Pressure (CPAP) or unassisted spontaneous ventilation with a T-piece can be used to similar effect. More recently, ventilators have been manufactured with Automatic Tube Compensation (ATC) settings, which allow for exact amounts of pressure to be delivered to overcome the intrinsic resistance of the endotracheal tube. This has also been shown to be at least as effective as lowered PSV in spontaneous breathing trials. The patient can be trialled from 30 min to 120 min at a time. Studies into the optimal duration of spontaneous breathing trials have shown either time periods to be comparable.

Conditions for passing or failing SBT, include adequacy of

gas exchange, haemodynamic stability and subject comfort. If the following are present, a patient should be deemed have failed the SBT:

#### 1 Clinical assessment and subjective indices

- a Agitation and anxiety
- b Depressed mental status
- c Diaphoresis
- d Cyanosis
- e Evidence of increasing effort
- f Increased accessory muscle activity
- g Facial signs of distress
- h Dyspnoea

#### 2 Objective measurements

- a PaO<sub>2</sub>  $\leq 6.67$ –8 kPa on FiO<sub>2</sub>  $\geq 0.5$  or SaO<sub>2</sub>  $< 90\%$
- b PaCO<sub>2</sub>  $> 6.67$  kPa or an increase in PaCO<sub>2</sub>  $> 1.07$  kPa
- c pH  $< 7.32$  or a decrease in pH  $\geq 0.07$
- d RR/TV  $> 105$  breaths/min/L
- e RR  $> 35$  breaths/min or increased by  $\geq 50\%$
- f HR  $> 140$  beats/min or increased by  $\geq 20\%$
- g Systolic BP  $> 180$  mmHg or increased by  $\geq 20\%$
- h Systolic BP  $< 90$  mmHg
- i Cardiac arrhythmias

**The following is a suggested protocol for conducting a spontaneous breathing trial**

- 1 Reduce/stop sedation such that patient takes spontaneous breaths.
- 2 Reduce ventilatory support to ATC (if available) for 30 minutes.
- 3 Stop the trial as soon as any of the above conditions appear.
- 4 If the patient successfully tolerates 30 minutes, consider extubation or consider extending trial to 120 minutes.
- 5 If patient fails trial, resume previous mechanical ventilation settings and gradually withdraw ventilation support (e.g. small decrements in FiO<sub>2</sub>, PS or PEEP).
- 6 Repeat trial the next day.

### Rapid shallow breathing index

Rapid and shallow breathing is common in patients who do not tolerate spontaneous breathing. A rapid-shallow breathing index is a ratio of respiratory rate (per minute) to tidal volume in litres (RR/Vt). The normal values are 20-40. An index above 100 is often found in patients who do not tolerate spontaneous breathing. The original study of the predictive value of the RR/Vt ratio showed that 95% of

patients with RR/Vt ratio above 105 failed discontinuing mechanical ventilation and 80% of patient with RR/Vt ratio below 105 were successfully weaned. Therefore, the results of this study establish a threshold RR/Vt ratio of approximately 100 for predicting success or failure to resume spontaneous breathing. However, whilst helpful, the positive and negative predictive values associated with such figures are low, and such assessment should thus not be used as a sole arbiter of likely success or failure.

### Difficulty in weaning

If a patient has been ventilated for a long time, it is usual to slowly reduce the degree of ventilatory support (over days or even weeks) as gas exchange improves, and to 'retrain the respiratory muscles'. Coming off a ventilator is easy if the patient is awake, aware and motivated, has good respiratory drive, can guard the airways, has a low work of breathing (good lung compliance, no airway obstruction) readily matched by 'fit' (strong, endurance-capable) ventilatory muscles, and with good cardiovascular reserve to cope with the extra workload imposed. Failing to 'get someone off the ventilator' (or make progress towards this) is 'failure to wean' – and – suggests a problem with one or more of these parameters.

### Pain and brain

*Inadequate analgesia* will hamper weaning, if breathing itself causes pain.

*Over-sedation* causing lack of motivation and engagement

*Depression*



**Poor respiratory drive** can result from:

- Too high an FiO<sub>2</sub> in those who normally rely on hypoxic ventilatory drive
- Alkalosis (are you over-ventilating the patient?)
- Too much sedation (especially with opioids)

Rarely, brainstem lesions can reduce drive, or subclinical seizures or rapid opiate withdrawal can impede weaning. Low mood and anxiety can also slow weaning.

### Weak respiratory muscles

**Specific muscle weakness** can result from nerve lesions (e.g. a phrenic nerve palsy in those with lung or mediastinal disease/thoracic surgery).

**Generalised loss of muscle bulk** can result from:

- Deconditioning
- Catabolism or poor nutrition
- Critical illness myoneuropathy

Assess muscle bulk in all groups, as well as tone, power and reflexes. EMG and nerve conduction studies can help confirm the diagnosis of myoneuropathy, but derived data are best after 3 weeks.

**Generalised muscle weakness** can also be due to:

- Drugs such as steroids
- Metabolic abnormalities (low phosphate, or low potassium for instance)

### Increased work of breathing

**Reduced chest compliance from extra-pulmonary factors**

- Ascites/obesity. Consider tapping/draining the ascites. Keep the patient 'sitting up'
- Spinal injury, or thoracic surgery reducing rib movement

**Pleural disease** – This is most commonly the result of accumulation of pleural effusions. Tap and drain as needed, but note that re-accumulation will occur if the patient remains total body water overloaded.

**Large airway narrowing** due to continued thick sputum production, tracheal stenosis, tracheobronchomalacia (long intubation can cause a 'floppy' collapsing airway), obesity (a fat neck encourages airway collapse), tracheal granulation tissue. Bronchoscopy can help here. If in doubt, seek specialist 'ENT' advice.

**Small airway narrowing** due to asthma or sputum retention

**Atelectasis or a missed lobar collapse** may impede weaning

**Continued or recurrent chest infection**

**Gas trapping** ( page 144)

### Cardiac disease

Cardiac failure can occur when demand for cardiac work exceeds the ability to respond.

- With a poor ventricle, agitation during weaning can cause a rise in afterload. Blood pressure then rises, with an increase in left atrial pressure and pulmonary oedema follows.

- The same can apply if there is mitral regurgitation: this can dramatically worsen (or even appear de novo) if afterload rises.
- Ischaemic failure may also occur during weaning.

One useful tip – *hypothyroidism* can reveal itself in the critically ill, and not only lessens central drive, but reduces cardiac and skeletal muscle performance.

Acute illness can make interpretation of thyroid function tests difficult ('sick euthyroid syndrome' or use of Amiodarone). Sometimes, a free T3 level is needed in addition to TSH and T4.

The level of ventilatory support needed during weaning can be judged from ABGs (rising CO<sub>2</sub> suggests 'tiring') and from clinical parameters (nasal flaring and use of accessory muscles suggest high ventilatory work). In a tiring patient we can observe rapid shallow breathing with fast respiratory rate and smaller tidal volumes. Muscle strength must also be assessed: critical illness myopathies not only affect peripheral muscle groups but also the respiratory muscles. As such, the assessment of peripheral muscle strength can provide an insight into how quickly a patient can be pushed in term of weaning. Similarly, the weaning process needs to be balanced with the increased metabolic demands caused by rehabilitation and strengthening. If a patient is weaned too aggressively, they may have little energy reserve to participate in rehabilitation and vice versa.

Involving the patient and providing visual feedback in the form of weaning charts can also help promote patient involvement.

## 20 Extubation

This should take place following a successful spontaneous breathing trial. The patient should be awake, able to cough and protect his/her own airway. The patient should be sat upright, and suction should be available. The cuff of the endotracheal tube can be deflated slightly to allow an audible air leak. The absence of an audible cuff leak may suggest some laryngeal oedema but is not a contraindication to extubation. The patient's oropharynx can be suctioned to remove excess secretions prior extubation. The endotracheal tube then can be removed swiftly with the patient giving a large cough.

### Post extubation stridor

Laryngeal oedema/granulation may cause significant airway obstruction (often evidenced by stridor) after extubation. The use of prophylactic corticosteroids (often dexamethasone 2-4mg IV prior to extubation and then 2 further doses 8 hours apart) may be beneficial in preventing post-extubation stridor. However, routine use is controversial – and most reserve this drug for those with evidence of no 'leak' to the mouth on cuff deflation.

Stridor after extubation is not always an indication for reintubation. If the patient is not in extremis, aerosolized Epinephrine (2.5ml 1% Epinephrine) can be used. Its efficacy has been proven in children, but remains arguable in adults. Dexamethasone is given as above.

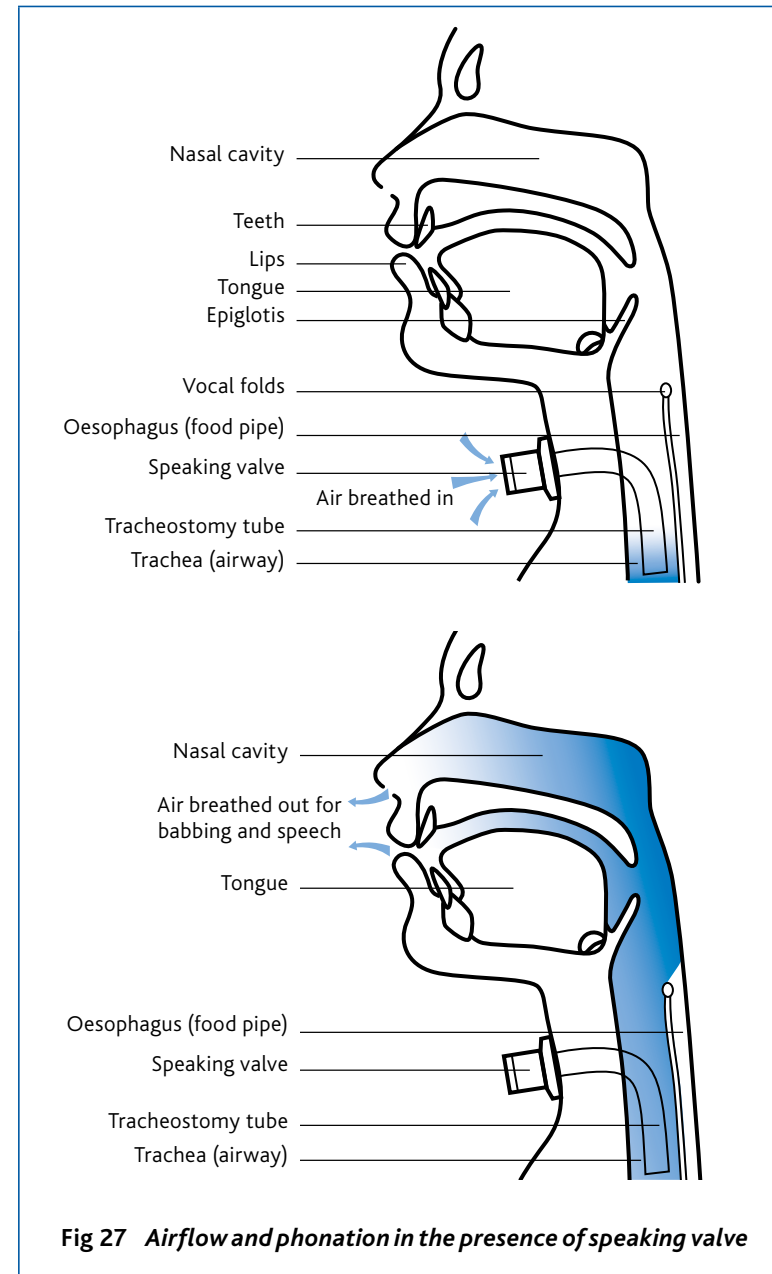

**Fig 27** Airflow and phonation in the presence of speaking valve

Breathing a helium-O<sub>2</sub> gas mixture (heliox) may help, but is unproven.

### The role of tracheostomies in weaning

Tracheostomies offer patient comfort, whilst maintaining airway protection and access for suctioning, and the ability to ‘connect and disconnect’ the patient. All these aid patient weaning. For patients with bulbar dysfunction, impaired swallowing or oro-motor weakness due to prolonged ventilation, a fenestrated tracheostomy and a program of cuff deflation can help to assess and retrain normal oro-motor control. Cuff deflation essentially re-opens the patient’s normal trachea. With the aid of speaking valve or Passy Muir valve, the patient can breathe in via their mouth and tracheostomy. However, when exhaling, the valve closes, enabling airflow to be redirected up past the vocal cords (🔗 *fig 27, page 165*). Whilst this is beneficial for communication, the patient may be at risk of aspirating saliva. Close monitoring of voice quality, cough strength, volume of secretions and respiratory parameters are needed when performing cuff deflation. Where problems with airway protection are suspected, periods of cuff deflation should be short, and slowly increased in duration.

To assess the readiness for decannulation, the opening of the tube is capped and the cuff deflated. The patient must now breathe entirely through the mouth. Any difficulty in breathing in this situation may suggest obstruction laryngeal/subglottic obstruction.

An example of weaning program for a patient with a tracheostomy is provided in 🔗 *page 153*.

## 21 Ventilatory support in special circumstances

### Asthma

Asthma, characterised by diffuse and reversible airway obstruction, is common: 21% of children and 15% of adults may be sufferers.

ICU referral is usually made when British Thoracic Society (BTS) Guideline therapy proves inadequate, or when the condition is life-threatening at presentation (🔗 *Table 8, below*).

Table 8
Indications for ICU referral <sup>3</sup>
Deteriorating/unresponsive PEFr/oxygenation
Hypercarbia or worsening acidosis
Exhaustion, feeble respiration
Clinically worrying work of breathing
Drowsiness, confusion, coma, respiratory arrest
Appropriate care level impossible elsewhere
Arterial line needed for Frequent ABGs

The severity of an asthma exacerbation varies (🔗 *Table 9, page 168*). All assessment must be put in context: a rising

PaCO<sub>2</sub> suggests respiratory fatigue, and one may be nearing a terminal phase without support.

Severities of asthma defined	
<b>Moderate</b>	PEFR >50-75% of best or predicted, with worsening symptoms No features of acute severe asthma
<b>Acute severe</b>	PEFR 33-50% of best or predicted Heart rate ≥110, Respiratory Rate ≥ 25 Unable to complete a sentence with one breath
<b>Life threatening</b>	PEFR <33% of best or predicted, Silent chest O <sub>2</sub> Sats <92%, PaO <sub>2</sub> <8 kPa, Cyanosis PaCO <sub>2</sub> 4.6 – 6.0 kPa (i.e. normal) Haemodynamically compromised Exhaustion or coma
<b>Near fatal</b>	PaCO <sub>2</sub> >6.0 kPa (i.e. raised)

Of note is the hypoxia. Simple increases in airway resistance shouldn't cause hypoxia, which occurs for one of three reasons:

- 1 There is underlying consolidation (e.g. from pneumonia, PE or pneumothorax) causing physiological shunt (👉 page 16)
- 2 There is thick tenacious sputum, causing poor V:Q matching (👉 page 22)
- 3 CO<sub>2</sub> levels are rising: with the same volume of air in alveoli, the amount of 'space left' for O<sub>2</sub> is less (alveolar gas equation, 👉 page 27). A rise in PaCO<sub>2</sub> suggests tiring (i.e. a failure to ventilate) – and this may suggest that the patient is near-terminal.

It is hard to tell whether 3 is present, even if one suspects (1 or 2). **This** is why hypoxia is such a red flag in asthma!

### ICU management

ICU may continue standard therapy, with the advantage of 1:1 nursing ratios, and arterial access for frequent ABG monitoring. However, if oxygenation is poor/worsening, hypercarbia is significant/worsening, or other medical complications are occurring (e.g. dysrhythmia), intubation is indicated.

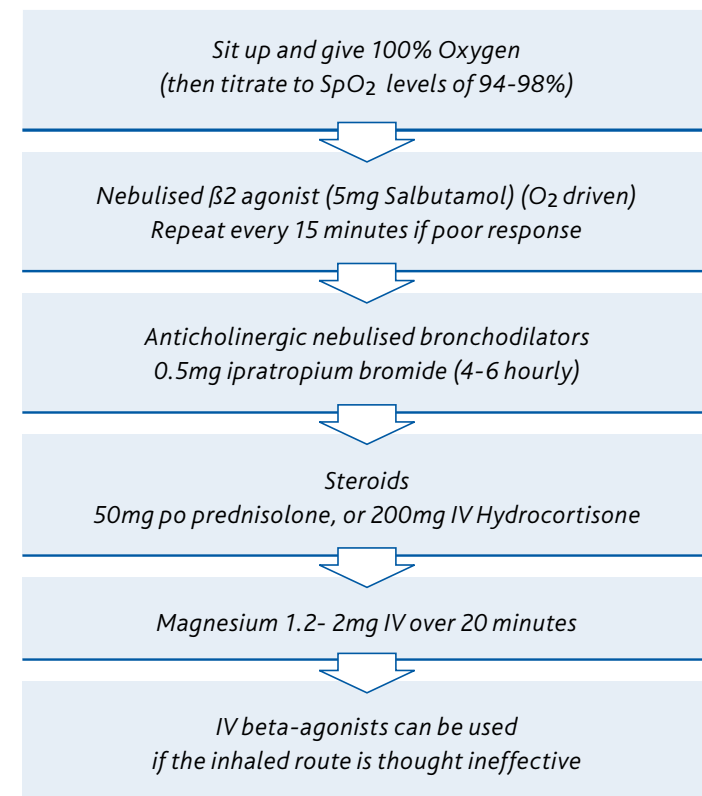

### Ventilator settings

- 1 Check you aren't starting with a pneumothorax.
- 2 Sedate the patient with a drug which doesn't cause histamine release (e.g. Propofol, or Fentanyl instead of Morphine). Short-acting agents are best: the patient is often extubated in a matter of 2-24 hours. If appropriate treatment isn't working, then Ketamine can be used (with a benzodiazepine): this dissociative anaesthetic is also a bronchodilator.
- 3 Paralyse the patient.
- 4 Start with a high  $FiO_2$ : 100%  $O_2$  initially, adjusted according to ABG analysis.
- 5 Start with low or no PEEP (ZEEP).
- 6 Start with a low respiratory rate, and low tidal volumes (TV). The main problem with asthmatics is **breathing out**, meaning that a ventilator may push air **in** which can't get fully **out**. This causes dynamic hyperinflation (👉 pages 144, 174), and a rise in thoracic pressure. This may prevent ventilation (airway pressures rise, TV fall), cause pneumothoraces or impair venous return and cause hypotension – so **AIR TRAPPING MUST BE AVOIDED**. Putting less gas in (low TV) and allowing plenty of time to breathe out (low respiratory rate) is a good start – perhaps 6 ml/kg TV at a rate of no more than 8-10 breaths/min. Then check that expiration has stopped before inspiration starts: listen to the chest, look for the fall in the chest wall to have ceased before inspiration, look at the graphics on the ventilator and make sure that expiratory flow stops before inspiration starts. If unsure, periodically disconnect

the ventilator and listen/feel at the ETT: gas may continue to slowly come out if trapping has occurred. This 'disconnect' manoeuvre may need to be repeated – but only while you set the ventilator correctly to stop the problem recurring. The period of expiration (E) may be lengthened compared to the period of inspiration i.e. I:E ratio is altered, perhaps to even 1:5 or 1:6.

- 7 Accept high  $PaCO_2$ s and acidaemia, a pH of 7.1 and a  $PaCO_2$  11kPa may be acceptable.
- 8 Keep the lungs moist. Thick clear tenacious sputum is characteristic of asthma, and bronchial casts clog up smaller bronchi. Thus, always use a heat:moisture exchanger (👉 page 51), and give frequent saline nebs between bronchodilator ones. In some cases, 10 ml saline should be squirted down the ETT every hour **and not immediately suctioned back**. This is to try to loosen secretions. Intravenous hydration may also be needed.
- 9 Watch the potassium, which falls with beta-agonist therapy. A central line may be needed for replacement.
- 10 If matters are worsening, consider using an inhalational volatile anaesthetic such as Isoflurane. However, you'll need expert help, as this isn't just a matter of plugging gas into a ventilator.
- 11 Keep the well-intentioned and ignorant away. They will be worried by a low pH and will try to increase ventilation rates. They might even want to give bicarbonate (which will just get buffered, making **more**  $CO_2$  – and which won't help pH!).
- 12 **BE PATIENT**. With appropriate therapy, it will all get better.

Pre-discharge, it is essential that the patient is reviewed by a respiratory physician. This will facilitate proper further investigation, and integrate the patient into appropriate follow-up.

### Chronic obstructive pulmonary disease (COPD)

COPD is characterised by airway obstruction, which is only partly reversible ('the asthmatic component'). Acute exacerbations (often of infective origin) are managed according to the 2010 NICE Guidelines, but poor treatment response may necessitate ICU admission for purposes of more intensive monitoring (for instance, with an arterial line), when ventilatory support is needed, or when other clinical states (hypotension, oliguria) coexist. The use of non-invasive ventilation (NIV) is discussed in *chapter 8* (📖 page 65). Analeptics (respiratory stimulants such as Doxapram) are no longer considered first line therapy and are only recommended if NIV is either unavailable or felt inappropriate.

#### ICU management

ICU may continue standard therapy, with the advantage of 1:1 nursing ratios, and arterial access for frequent ABC monitoring. However, if oxygenation is poor/worsening, hypercarbia is significant/worsening, or other medical complications are occurring (e.g. dysrhythmia), intubation may be indicated. The goal of ventilating these patients is to allow time for pharmacological therapies to work and to rest the exhausted ventilator muscles, whilst improving gas exchange. Remember, no single measure has good positive predictive value for determining success or failure

of intensive treatment, and outcome may be better than we think: a US study of patients admitted to ICU with an exacerbation of COPD showed that the 2, 6, 12 and 24 month mortality rates were 20%, 33%, 43% and 49% respectively, where the mean age was 70 and median FEV1 0.8.<sup>3</sup> Further, quality of life (considered poor by us) may in fact be very acceptable to the patient. In general, then, one should err on the side of giving, rather than withholding, mechanical ventilatory support. Where possible, a competent patient should be given a choice.

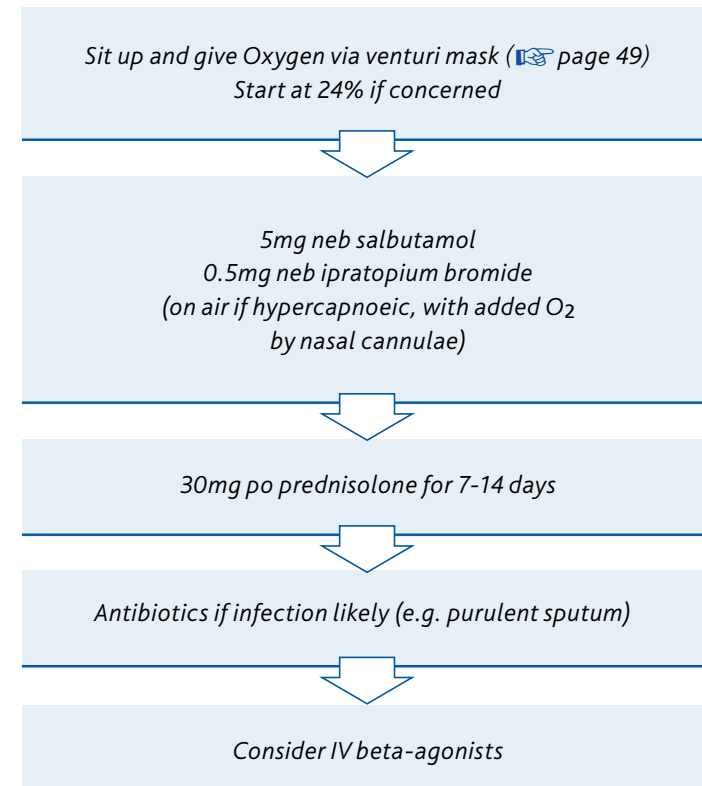

### Ventilator settings

- 1 Check you aren't starting with a pneumothorax.
- 2 Sedate the patient with a drug which doesn't cause histamine release (e.g. Propofol, or Fentanyl instead of Morphine) if there is thought to be a significant 'asthmatic' component. Short-acting agents are best: the patient is often extubated in a matter of 2-24 hours. If appropriate treatment isn't working, then Ketamine can be used (with a benzodiazepine): Ketamine has bronchodilating properties.
- 3 Paralyse the patient to start with, in general.
- 4 Select the  $FiO_2$  appropriate to the patient. If hypoxic ventilatory drive is suspected (known  $CO_2$  retention, as evidenced by polycythaemia, or metabolic compensation for respiratory acidosis, [page 24](#)), then aim for  $SaO_2$  88-92%.
- 5 Start with low tidal volumes and a low respiratory rate, for reasons explained under 'asthma' ([page 167](#)).
- 6 Avoid over-ventilation. COPD patients often run a high  $CO_2$  and bicarbonate levels when 'well'. 'Correcting' the  $CO_2$  will initially cause an alkalosis (and apnoeic periods later), before pH normalises... and then possibly a respiratory acidosis as you wean. Further, if COPD patients are ventilated with 'normal' minute volumes in order to reduce the  $CO_2$  this may lead to additional gas trapping due to a reduced expiratory time ([page 144 and below](#)).

- 7 Beware gas trapping and adjust PEEP. Assess expiratory gas flow as for asthma, and adjust I:E ratio/Respiratory Rate/TV appropriately. Initially, accept worsening pH/ $CO_2$  as you 'play yourself in'. But adjusting PEEP is tricky, and can be counter-intuitive. Imagine that you have a slow rate and long expiratory time, but find evidence of gas trapping and a rising 'auto-PEEP' ([page 144](#)). The presence of auto-PEEP will make inspiration harder as gas will not flow into the lungs until the level of auto-PEEP is offset. In controlled mechanical ventilation inspiratory flow will not start until airway pressure rises above the level of auto-PEEP while during spontaneous breathing an equivalent reduction in pleural pressure needs to occur which can represent a significant load to inspiration. Applying external PEEP is not usually additive to the auto-PEEP level and therefore will reduce the pressure gradient between the ventilator and the lungs, which will counteract the effects of auto-PEEP on inspiration. Matching the external PEEP level to the auto-PEEP level can therefore significantly reduce patient work of breathing during spontaneous breathing efforts (e.g. triggering, pressure support). External PEEP may also been used to reduce gas trapping by splinting the airways open and prevent airway collapse during expiration. This is controversial but is most likely to be effective in the patient with emphysema when dynamic airway closure occurs and is analogous to breathing out through pursed lips. If attempted, PEEP should be progressively applied while the total PEEP level is monitored. If effective in reducing gas trapping the total PEEP, peak airway pressures and trapped gas volume should all reduce as a consequence.



## Acute respiratory distress syndrome (ARDS)

ARDS is triggered by pulmonary injury (most commonly pneumonia, but also aspiration, contusion, smoke inhalation, pneumonitis, or even fat/amniotic fluid embolus) or extra-pulmonary conditions (most commonly sepsis, but also conditions including massive transfusion, trauma or burns). In response, protein-rich fluid leaks from pulmonary capillaries, causing 'low left atrial pressure pulmonary oedema'. The hallmarks are bilateral pulmonary infiltrates on chest radiography and a  $\text{PaO}_2/\text{FiO}_2$  ratio of  $<300\text{mmHg}$  or  $40\text{ kPa}$ , in the absence of suspected cardiogenic pulmonary oedema. The condition is inflammatory – neutrophils are recruited and activated – and is followed (at 10-14 days) by fibroproliferative (scarring) phase of variable severity. The result is hypoxia (due to V:Q mismatch). Reduced lung compliance (initially by loss of surfactant and alveolar collapse, but later due to fibroproliferation or 'lung scarring') causing a high work of breathing and low tidal volumes. Ineffective ventilation thus can cause  $\text{PaCO}_2$  to rise. Pulmonary artery pressures can rise (due to hypoxic pulmonary vasoconstriction).

### ICU Management

ICU management is mandatory. An arterial line must be placed, and central venous access secured. Whilst NIV may be attempted in the early phases, intubation and mechanical ventilation are likely to be needed. Multiple organ failure often follows. Up to 1/3 of patients don't survive.

There are **five keys to management**:

- 1 The underlying cause of the ARDS must be sought and treated. If there is no obvious septic source, look in

the ears, perform a vaginal examination, think of the abdomen... Hunt down the bugs. If infection is unlikely, then what **IS** the cause?

- 2 Minimise airway pressures. High airway pressures and high tidal volumes may damage the lungs, worsen the ARDS, and worsen outcome.
- 3 Avoid 'second hits'. Aspirating feed/developing ventilator-associated pneumonia (VAP) during recovery from ARDS may trigger full blown ARDS again but outcome is often far worse on the 'second episode'.
- 4 In the early phase of sepsis, large volume resuscitation is necessary. Once over 'the acute hit', ARDS does better with a dryer (rather than wetter) patient.
- 5 Time is a healer. Just because things look as if they are improving, don't wind back on support too fast.

### Ventilator settings

- 1 *Initially, sedate and paralyse your patient in order to get control.*
- 2 *Start with pressure control ventilation, and aim for tidal volumes of 6ml/kg ideal body weight, calculated as:*
  - a *For males:  $50 + 0.91$  (height in cm - 152.4)*
  - b *For females:  $45.5 + 0.91$  (height in cm - 152.4)*

- 3** *Recruit alveoli. Alveolar recruitment is a method of attempting to improve oxygenation in a patient who acutely desaturates despite being ventilated. There are plenty of ways, but one is to apply PEEP of 40 cm H<sub>2</sub>O for 40 seconds via the ventilator or a Water's circuit. Be prepared that the shorter the duration of the recruitment manoeuvre the shorter the duration of the increase in PaO<sub>2</sub>, particularly if PEEP is not adjusted.*
- 4** *Adjust PEEP. In general, much higher PEEP is required, just to keep surfactant-depleted alveoli open. In general, the following PEEP/FiO<sub>2</sub> scale can be used:*
- |                        |       |       |     |       |     |      |     |     |
|------------------------|-------|-------|-----|-------|-----|------|-----|-----|
| <b>FiO<sub>2</sub></b> | 1.0   | 0.9   | 0.8 | 0.7   | 0.6 | 0.5  | 0.4 | 0.3 |
| <b>PEEP</b>            | 20-24 | 14-18 | 14  | 10-14 | 10  | 8-10 | 5-8 | 5   |
- 5** *Once the alveoli are open, keep them open. The cyclical opening and closing of alveoli has also been blamed for further cytokine release and lung injury during ventilation due to shearing. Meanwhile, as PEEP is lost, alveoli collapse and are hard to recruit. Avoid, for instance, repeated disconnections from the ventilator.*
- 6** *Aim for an upper limit of plateau pressure of 28-30 cmH<sub>2</sub>O.*
- 7** *Consider adjusting the I:E ratio.*
- 8** *Accept low O<sub>2</sub> levels, allowing targets to drift down over days. O<sub>2</sub> itself at high concentration can cause*

- pulmonary injury, and also collapse of alveoli. The body adapts to lower O<sub>2</sub> given time: with a week of ascent up a mountain, SaO<sub>2</sub> <80% are perfectly survivable. As a rule of thumb, SaO<sub>2</sub> >90% and PaO<sub>2</sub> >8kPa is a good target within a day or two.*
- 9** *Accept high PaCO<sub>2</sub>. These are inevitable if tidal volumes and plateau pressures are low. With time, renal compensation will normalise the pH.*
- 10** *If failing to oxygenate, consider early prone positioning. If you've done everything, and your patient is still on 95% inspired O<sub>2</sub> with a PaO<sub>2</sub> of 6kPa, you might wish to do something to lower FiO<sub>2</sub>. Gravity may have gathered pulmonary fluid and secretions in the posterior 'dependent' lung, where gravity is also diverting much of the blood flow. The worst-ventilated lung is thus best perfused. Nursing the patient on their front thus decreases the pleural pressure of the dorsal zones leading to alveolar opening and **vice versa** increase pleural pressure of the ventral zones reducing hyperinflation. The importance of blood-flow diversion is less important than initially thought. Note however that the turn itself needs a lot of staff (generally 8 people), and its own risks (e.g. accidental extubation, loss of vascular access, or haemodynamic instability). This is a consultant decision, and needs trained and experienced nursing staff. Recently, a large mortality benefit has been demonstrated in the more severe group of patients with ARDS.*

- 11 Consider other adjuvant therapies. Inhaled nitric oxide, or nebulised prostacyclin can all improve V:Q matching and thus oxygenation (👉 page 16), but proof of outcome benefit is lacking.

*Note: although ARDS is an inflammatory condition, corticosteroids are not recommended as part of treatment. A study in 2006 involving 180 patients with ARDS showed that although methylprednisolone could improve cardiopulmonary physiology, there was no improvement in mortality at 60 days. In fact, there was some evidence that if they were started after 14 days, there was actually an increased risk of mortality.*

- 12 Consider referral to a Severe Respiratory Failure Centre for extracorporeal oxygenation support.

## Cardiogenic shock

Cardiogenic shock is a serious condition characterised by global hypo-perfusion caused by inadequate ventricular function. Patients should be admitted to ICU, as even with the most intensive management cardiogenic shock carries a mortality of approximately 90%. Numerical definitions include a systolic BP <90 mmHg for >30mins, and a cardiac index of <2.2L/min/m<sup>2</sup>. It most commonly occurs as a direct result of myocardial infarction: the SHOCK trial (“Should We Emergently Revascularize Occluded Coronaries for Cardiogenic Shock?”) found that 75% of cases of cardiogenic

shock secondary to myocardial infarction occurred within 24 hours of the event.

## ICU management

An arterial line must be placed, and the patient will need central venous access to monitor CVP and venous oxygenation, and to allow infusion of inotropic agents. The management of this condition is beyond the scope of this text, but strategies are aimed at improving O<sub>2</sub> delivery (ensure adequate cardiac filling, improve contractility using inotropes, adjust afterload to maintain perfusion and pressure, ensure Hb >10g/dl). Causes should be treated (e.g. sustained tachyarrhythmias) and pericardial tamponade excluded. In the context of acute ischaemia, immediate referral for consideration of revascularisation is mandatory. The ‘SHOCK’ study was conducted over 5 years in the US, with over 300 patients participating, who either received intensive medical management, including Intra-Aortic Balloon Pumps (IABPs), or percutaneous intervention or coronary-artery bypass grafting (CABG). The results showed a significant absolute mortality reduction of 12.8% in the revascularisation group at 6 months – a benefit since shown to be sustained at 6 years. The benefits are derived from preserving as much function as possible within the left ventricle. In addition, failure due to reversible causes such as myocarditis may benefit from mechanical assist devices.

## Ventilation

In *acute pulmonary oedema*, the use of NIV is often successful in avoiding intubation and ventilation (👉 page 65). However, sedation and paralysis will remove substantial O<sub>2</sub>

demand, and completely remove that due to the work of breathing. Thus, intubation and mechanical ventilation are required.  $\text{FiO}_2$  should be raised to completely correct any hypoxaemia.

In **right ventricular failure**, cautious filling may be required, to ensure adequate preload, and low PEEP (3-5cm  $\text{H}_2\text{O}$ ) should be used (as higher PEEP may compromise RV filling).

In **left ventricular failure**, higher PEEP may be needed to address pulmonary oedema, but the minimum of benefit should be used once oxygenation is normalised.

### Community acquired pneumonia (CAP)

CAP is usually bacterial, with a single organism identified in 85% of cases.

- ***Streptococcal/pneumococcal pneumonia***  
Most common and mainly in winter. It can be associated with diarrhoea and/or a metabolic acidosis may be early pointers.
- ***Legionella species***  
52% of cases in UK related to travel (esp. from Mediterranean air conditioning units. Mainly September/October).
- ***Staphylococcus (staph.) aureus***  
50% of those admitted to ICU have co-incident infection with influenza viruses (thus winter prevalence). NB feature of generalised staph sepsis (including endocarditis).

- ***Mycoplasma pneumoniae***  
epidemics every 4 – 5 yrs
- ***Influenza***  
Viral. Mainly winter. 3% develop pneumonia. Often co-infected with *S. Aureus*.
- ***Chlamydia (uncommon)***
  - *psittaci*: 20% history of bird contact
  - *burnetti*: occupational exposure (sheep) in 8%

CAP leads to hospital admission in 22-42% of cases, amongst whom mortality is 5-14%, and up to 50% for those needing ICU admission. (*See below for poor prognostics factors.*)

#### Poor prognostic factors include:

- $\text{PaO}_2 < 8$  kPa
- White Cell Count  $< 4$  or  $> 20 \times 10^9$
- Radiology: bilateral or multilobar involvement and progressive changes in ventilated patients
- Co-morbidities (cardiac/diabetes/COPD)
- *Confusion: Mini Mental state exam  $< 8$*
- *Urea  $> 7$  mmol/l*
- *RR  $> 30$ /min (very reliable predictor of severity but will often be high at baseline in severe COPD)*

- *A positive blood culture*
- *BP low (systolic <90 mmHg, Diastolic <60 mmHg)*
- *Age >65*

Those *in italics* ('CURB 65') have been included in a 6 point prognostic score:

Score	30-day Mortality (%)
0	0.7
1	3.2
2	13
3	17
4	41.5
5	57

## 22 Extracorporeal support

### Extracorporeal membrane oxygenation (ECMO)

ECMO uses a simplified cardiopulmonary bypass (CPB) technology to provide respiratory (veno-venous ECMO) or cardio-respiratory (veno-arterial ECMO) support. The main indication for VV-ECMO is in patients with severe respiratory failure who fail conventional treatment, have a reversible cause of respiratory failure and no contraindication to systemic anticoagulation, which is necessary in order to avoid clotting of the extracorporeal circuit. ECMO is a specialised technique that should be offered only in ECMO centres which can be found on the Extracorporeal Life Support Organisation (ELSO) website. In VV-ECMO, blood is removed from one or both vena cavae via the jugular or femoral veins, pumped through an oxygenator and returned directly into the right atrium, thereby preserving pulmonary blood flow, pulsatile systemic flow, and oxygenation of blood in the left ventricle and aortic root.

ECMO circuits have two principal components: the oxygenator and the pump. Additional circuit components include cannulas, tubing and the heat exchanger.

#### The Pump

The pump is the heart of the ECMO circuit. There are two types of pumps currently available. These are the centrifugal pump and the roller pump:

Centrifugal pumps that utilize the spinning action of cones to create a vortex that suctions blood into the pump-head and propels it out toward the oxygenator. Centrifugal pumps must be used with venous line pressure monitoring to prevent excessive negative pressure and haemolysis.

### Oxygenators

These are more correctly termed 'membrane lungs' as their function is gas exchange. Modern Polymethylpentene (PMP) hollow fiber oxygenators have a lower resistance, lower priming volume and are more biocompatible. PMP oxygenators do not develop the plasma leak seen with polypropylene devices. A sweep gas flows through the oxygenator in a counter-current direction to the blood flow and this controls CO<sub>2</sub> removal. Oxygenation is controlled by increasing the blood flow rate (4-5 L/min), and CO<sub>2</sub> by increasing the sweep gas flow rate. The sweep gas flow is generally started at 4-5 L/min and then titrated to keep the PaCO<sub>2</sub> within normal range. Heparin can usually be titrated to maintain activated partial thromboplastin times (APTT) at 1.2–1.8 times normal (measured daily). Alternatively, activated clotting times (ACT) 1.5 times normal (measured hourly) can be targeted.

Once the patient is on ECMO, a 'lung rest' ventilation is applied to minimise ventilator-associated lung injury using peak pressures of 20-25 cmH<sub>2</sub>O, PEEP 10 cmH<sub>2</sub>O, RR 10/min and FiO<sub>2</sub>=0.3.

### Extracorporeal CO<sub>2</sub> removal (ECCO<sub>2</sub>R)

Arterio-venous (or more recently veno-venous) CO<sub>2</sub> removal is much simpler than ECMO. The circuit blood flow is much lower than in ECMO (around 1L/min). For the arterio-

venous system, flow is 'pushed' by arterial blood pressure via a 13F cannula in the femoral artery, through a low-resistance PMP membrane and then returned to the patient via a cannula sited in the opposite femoral vein. The system is very effective in controlling CO<sub>2</sub> via a sweep gas flow, but does not provide significant increase in oxygenation. Effective CO<sub>2</sub> clearance can be achieved with as little as 10-15 ml/kg/min of blood flow, while effective oxygenation usually requires at least 50-60 ml/kg/min, although this value can be as high as 80-100 ml/kg/min and varies with both the amount of recirculation and total CO<sub>2</sub>. Similar to ECMO, ECCO<sub>2</sub>R requires anticoagulation to prevent circuit/membrane clotting.

## Additional Reading

### Anatomy and physiology

Lumb AB. *Nunn's applied respiratory physiology*, Elsevier, 2005.

Hess DR and Kacmarek RM. *Indices of oxygenation and ventilation. Essential of mechanical ventilation*. McGraw-Hill, 2002; 240-245.

Macklem PT. *Respiratory mechanics*. Annu Rev Physiol, 1978; 40: 157-84.

Roussos C and Macklem PT. *The respiratory muscles*. N Engl J Med, 1982; 307(13): 786-97.

Macklem PT, Gross D, et al. *Partitioning of inspiratory pressure swings between diaphragm and intercostal/accessory muscles*. J Appl Physiol, 1978; 44(2): 200-8.

Mellemgaard K. *The alveolar-arterial O<sub>2</sub> difference: its size and components in normal man*. Acta Physiol Scand, 1966; 67(1): 10-20.

### Respiratory Failure

Roussos C. *Respiratory muscle fatigue and ventilatory failure*. Chest, 1990; 97(3 Suppl): 895-965.

Roussos C. and Koutsoukou A. *Respiratory failure*. Eur Respir J, 2003; Suppl 47: 3s-14s.

Tobin MJ. *Respiratory muscles in disease*. Clin Chest Med, 1988; 9(2): 263-86.

Wood LD. *The pathophysiology and differential diagnosis of acute respiratory failure. Principles of Critical Care*. J B Hall, G A Schmidt and L D Wood, McGraw-Hill, 2005: 417-426.

### Supplemental oxygen therapy

British Thoracic Society Emergency Oxygen Guideline Group. *Guideline for emergency oxygen use in adult patients*. Thorax, 2008; 63(Suppl VI):vi1-vi68.

### Humidification

Pelosi P, Solca M, Ravagnan I, et al. *Effects of heat and moisture exchangers on minute ventilation, ventilatory drive and work of breathing during pressure/support ventilation in acute respiratory failure*. Crit Care Med, 1996; 24: 1184-8

Le Bourdelles G, Mier L, Fiquet B, et al. *Comparison of the effects of heat and moisture exchangers and heated humidifiers on ventilation and gas exchange during weaning trial from mechanical ventilation*. Chest, 1996; 110: 1294-8.

Djedaini K, Biliard M, Mier L, Le Bourdelles G, Brun P and Markowicz P. *Changing heat and moisture exchangers every 48 hours rather than 24 hours does not affect their efficacy and the incidence of nosocomial pneumonia*. Am J Respir Crit Care Med, 1995; 152: 156-69.

Gallagher J, Strangeways JEM and Allt-Graham J. *Contamination control in long-term ventilation: a clinical study using heat and moisture exchanging filter*. Anaesthesia, 1987; 42: 476-81.

Thomachot L, Vialet R, Viguier JM, Sidier B, Roulier P and Martin C. *Efficacy of heat and moisture exchangers after changing every 48 hours rather than every 24 hours*. Crit Care Med, 1998; 26: 477-81.

Thomachot L, Boisson C, Arnaud S, Michelet P, Cambon S and Martin C. *Changing heat and moisture exchangers after 96 hours rather than 24 hours: a clinical and microbiological evaluation*. Crit Care Med 2000; 28: 714-20.

### Non-invasive ventilation (NIV)

Plant PK, Owen JL and Elliot MW. *One year period prevalence study of respiratory acidosis in acute exacerbations of COPD: implications for the provision of non-invasive ventilation and oxygen administration*. Thorax, 2000; 55: 550-4.

### Cricothyroidotomy

American College of Surgeons, 2005. *Advanced Trauma Life Support for Doctors, 7th Edition*. American College of Surgeons, Chicago.

### Adjuncts to care in ventilated patients

Harvey CJ, et al. *Comparison of jet and ultrasonic nebulizer pulmonary aerosol deposition during mechanical ventilation*. Eur Respir J, 1997; 10: 905-909.

Miller DD, et al. *Aerosol delivery and modern mechanical ventilation: in vitro/in vivo evaluation*. Am J Respir Crit Care Med, 2003; 168(10): 1205-1209.

Dhand R. *Special problems in aerosol delivery: artificial airways*. Respir Care, 2000; 45(6): 636-645.

Dhand R. *Basic Techniques for Aerosol Delivery During Mechanical Ventilation*. Respiratory Care, 2004; 49(6): 611-622.

### Weaning and extubation

Boles JM, et al. *Weaning from mechanical ventilation*. Eur Respir J, 2007; 29(5): 1033-56.

Epstein SK. *Weaning from ventilatory support*. Curr Opin Crit Care, 2009; 15(1): 36-43.

Esteban A, et al. *Extubation outcome after spontaneous breathing trials with T-tube or pressure support ventilation*. The Spanish Lung Failure Collaborative Group. Am J Respir Crit Care Med, 1997; 156(2 Pt 1): 459-65.

Esteban A, et al. *A comparison of four methods of weaning patients from mechanical ventilation*. Spanish Lung Failure Collaborative Group. N Engl J Med, 1995; 332(6): 345-50.

Cohen J, et al. *Prediction of extubation outcome: a randomised, controlled trial with automatic tube compensation vs. pressure support ventilation*. Crit Care, 2009; 13(1): R21.

Perren A, et al. *Protocol-directed weaning from mechanical ventilation: clinical outcome in patients randomized for a 30-min or 120-min trial with pressure support ventilation*. Intensive Care Med, 2002; 28(8): 1058-63.

Esteban A, et al. *Effect of spontaneous breathing trial duration on outcome of attempts to discontinue mechanical ventilation*. Spanish Lung Failure Collaborative Group. Am J Respir Crit Care Med, 1999; 159(2): 512.

Cheng KC, et al. *Intravenous injection of methylprednisolone reduces the incidence of postextubation stridor in intensive care unit patients*. Crit Care Med, 2006; 34(5): 1345-50.

Epstein SK. *Corticosteroids to prevent postextubation upper airway obstruction: the evidence mounts*. Crit Care, 2007; 11(4): 156.

Lee CH, Peng MJ and Wu CL. *Dexamethasone to prevent postextubation airway obstruction in adults: a prospective, randomized, double-blind, placebo-controlled study*. Crit Care, 2007; 11(4): R72.

Markovitz BP, Randolph AG and Khemani AG. *Corticosteroids for the prevention and treatment of post-extubation stridor in neonates, children and adults*. Cochrane Database Syst Rev, 2008(2): CD001000.

Fan T, et al. *Prophylactic administration of parenteral steroids for preventing airway complications after extubation in adults: metaanalysis of randomised placebo controlled trials*. BMJ, 2008; 337: a1841.

Young D and Watkinson P. *Preventing postextubation airway complications in adults*. BMJ, 2008; 337: a1565.

Yang K and Tobin MJ. *A prospective study of indexes predicting the outcome of trial of weaning from mechanical ventilation*. N Engl J Med, 1991; 324: 1445-1450

### Ventilatory support in special circumstances

Burden of Lung Disease, *2nd Edition*. British Thoracic Society. London: 2006.

Office for National Statistics. *Mortality statistics: Cause, 1999. DH2 (No 26)*. 2000; London. HMSO.

### Asthma

International consensus report on the diagnosis and treatment of asthma. *National Heart, Lung and Blood Institute, National Institute of Health*. Bethesda, Maryland 20892. Publication no 93-3091, March 1992. Eur Respir J, 1992; 5: 601-41.

British Guideline on the Management of Asthma. British Thoracic Society and Scottish Intercollegiate Guidelines Network. 2012 <https://www.brit-thoracic.org.uk/document-library/clinical-information/asthma/btssign-guideline-on-the-management-of-asthma/>

### COPD

Connors AF, Dawson NV, Thomas C, Harrell FE, Desbiens N, Fulkerson WJ, et al. *Outcomes following acute exacerbation of severe chronic obstructive lung disease*. Am J Resp Crit Care Med, 1996; 154: 959-67.

### ARDS

The ARDS Definition Task Force. *Acute respiratory distress syndrome, the Berlin definition of ARDS*. JAMA 2012, 307(23):2526-33.

### Pneumonia

Lim WS, Baodouin SV, George RC, et al. *BTS guidelines for the management of community-acquired pneumonia in adults: update 2009*. Thorax 2009; 64 (Suppl 3): iii1-55.

<http://www.anaesthesiauk.com/article.aspx?articleid=100810>

<http://www.anaesthesiauk.com/article.aspx?articleid=100813>



Steinberg KP, Hudson LD, Goodman RB, Hough CL, Lankester PN, Hyzy R, Thompson BT, Ancukiewicz M; National Heart, Lung, and Blood Institute Acute Respiratory Distress Syndrome (ARDS) Clinical Trials Network. *Efficacy and safety of corticosteroids for persistent acute respiratory distress syndrome.* N Engl J Med, 2006; 354: 1671-1684.

Adhikari NKJ, et al. *Effect of nitric oxide on oxygenation and mortality in acute lung injury: systematic review and meta-analysis.* BMJ, 2007; 334: 779.

Young D, Lamb SE, Shah S, MacKenzie I, Tunnicliffe W, Lall R, Rowan K, Cuthbertson BH, Group OS: *High-frequency oscillation for acute respiratory distress syndrome.* N Engl J Med, 2013; 368(9): 806-813.

Ferguson ND, Cook DJ, Guyatt GH, Mehta S, Hand L, Austin P, Zhou Q, Matte A, Walter SD, Lamontagne F, et al, *High-frequency oscillation in early acute respiratory distress syndrome.* N Engl J Med, 2013; 368(9): 795-805.

Guerin C, Reignier J, Richard JC, Beuret P, Gacouin A, Boulain T, Mercier E, Badet M, Mercat A, Baudin O, et al, *Prone positioning in severe acute respiratory distress syndrome.* N Engl J Med, 2013; 368(23): 2159-2168.

### **Shock**

Hochman JS, Sleeper LA, Webb JG, Sanborn TA, White HD, Talley JD, et al. *Early revascularization in acute myocardial infarction complicated by cardiogenic shock. SHOCK Investigators. Should We Emergently Revascularize Occluded Coronaries for Cardiogenic Shock.* N Engl J Med, 1999; 341(9): 625-34.

Hochman JS, Sleeper LA, Webb JG, Dzavik V, Buller CE, Aliward P et al. *Early revascularisation and long-term survival in cardiogenic shock complicating acute myocardial infarction.* JAMA, 2006; 295(21): 2511-2515.

Rivers E, Nguyen B, et al. *Early goal-directed therapy in the treatment of severe sepsis and septic shock.* N Engl J Med, 2001; 345(19): 1368-77.