

# Power Systems Protection, Power Quality

and Substation Automation

IDC Technologies

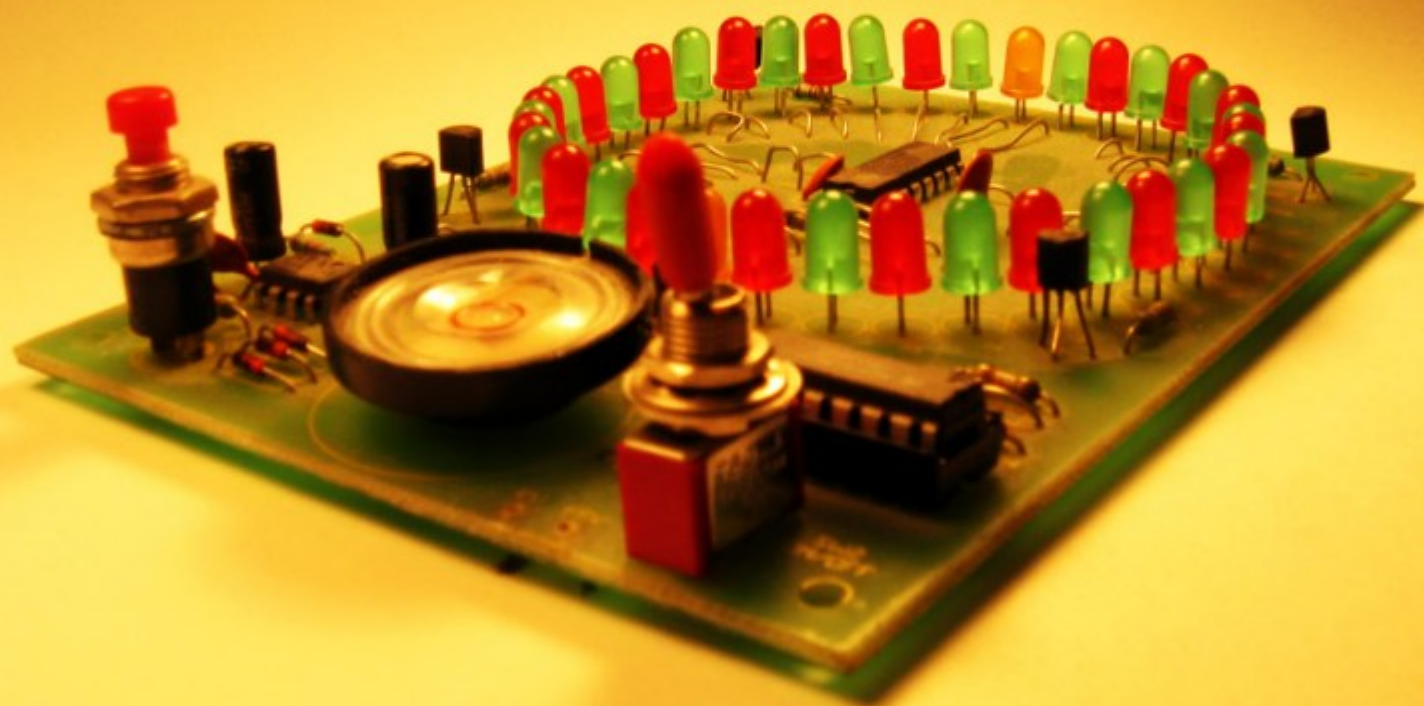

Download free books at

[bookboon.com](http://bookboon.com)

IDC Technologies

# Power Systems Protection, Power Quality and Substation Automation

---

Power Systems Protection, Power Quality and Substation Automation  
© 2012 IDC Technologies & Ventus Publishing ApS  
ISBN 978-87-7681-974-3

# Contents

	<b>Foreword</b>	<b>7</b>
<b>1</b>	<b>Power Quality</b>	<b>8</b>
1.2	Surges and Transients	10
1.3	Harmonics and Distortions	11
1.4	Interruptions	11
1.5	Noise Disturbances	12
1.6	Notching	13
1.7	Noise Definitions	14
1.8	Recommended Design and Installation Practices	15
1.9	Zero Signal Reference Grid (ZSRG)	16
<b>2</b>	<b>Electrical Protection for Power Systems</b>	<b>19</b>
2.1	The Need for Electrical Protection	19
2.2	Protective Relays	19
2.3	The Basic Requirements of Protection	19
2.4	Electrical Faults	20
2.5	Transient & Permanent Faults	21
2.6	Calculation of Short Circuit Currents	21

Please click the advert



 **OLIVER WYMAN**



Oliver Wyman is a leading global management consulting firm that combines deep industry knowledge with specialized expertise in strategy, operations, risk management, organizational transformation, and leadership development. With offices in 50+ cities across 25 countries, Oliver Wyman works with the CEOs and executive teams of Global 1000 companies.  
An equal opportunity employer.

**GET THERE FASTER**

Some people know precisely where they want to go. Others seek the adventure of discovering uncharted territory. Whatever you want your professional journey to be, you'll find what you're looking for at Oliver Wyman.

Discover the world of Oliver Wyman at [oliverwyman.com/careers](http://oliverwyman.com/careers)





2.7	Fuses	22
2.7	The Relay - Circuit-Breaker Combination	24
2.8	Circuit Breaker Tripping Times	25
2.9	Instrument Transformers	26
2.10	Current Transformer (CT) Magnetization Curve	26
2.11	Knee-Point Voltage	27
2.12	Metering CTs	27
2.14	Open Circuiting of CTs	27
2.15	CT Specification	28
2.17	Voltage Transformers	28
2.18	IDMT Relays	29
2.19	Why IDMT?	31
<b>3</b>	<b>Substation Automation</b>	<b>34</b>
3.1	Definition of the Term	34
3.2	What is Substation Automation?	35
3.4	Control	36
3.6	Monitoring	37
3.7	Data Communication	37
3.8	Substation Automation Architecture	37
3.9	The modern system consists of three main divisions:	38
3.10	Communications in Substation Automation	40

Please click the advert

**Day one**  
and you're ready

Day one. It's the moment you've been waiting for. When you prove your worth, meet new challenges, and go looking for the next one. It's when your dreams take shape. And your expectations can be exceeded. From the day you join us, we're committed to helping you achieve your potential. So, whether your career lies in assurance, tax, transaction, advisory or core business services, shouldn't your day one be at Ernst & Young?

**What's next for your future?**  
[ey.com/careers](http://ey.com/careers)

**ERNST & YOUNG**  
Quality In Everything We Do

© 2010 EYGM Limited. All Rights Reserved.

<b>Appendix A</b>	
<b>Glossary of Terms</b>	<b>43</b>
<b>Appendix B</b>	
<b>Units and Abbreviations</b>	<b>69</b>
<b>Appendix C</b>	
<b>Commonly used Formulae</b>	<b>71</b>
Symbols used in formulae	71
Formulae	73
<b>Appendix D</b>	
<b>Resistor Color Coding</b>	<b>78</b>
Common Band Colors	79
<b>Who is IDC Technologies</b>	<b>80</b>
The Benefits to You of Technical Training	80
Technical Training Workshops	81
IDC Technologies - Worldwide Offices	88

Please click the advert



Hellmann's is one of Unilever's oldest brands having been popular for over 100 years. If you too share a passion for discovery and innovation we will give you the tools and opportunities to provide you with a challenging career. Are you a great scientist who would like to be at the forefront of scientific innovations and developments? Then you will enjoy a career within Unilever Research & Development. For challenging job opportunities, please visit [www.unilever.com/rdjobs](http://www.unilever.com/rdjobs).

Could it be   
Unilever



# Foreword

IDC Technologies specializes in providing high quality state-of-the-art technical training workshops to engineers, scientists and technicians throughout the world. More than 300,000 engineers have attended IDC's workshops over the past 16 years. The tremendous success of the technical training workshops is based in part on the enormous investment IDC puts into constant review and updating of the workshops, an unwavering commitment to the highest quality standards and most importantly - enthusiastic, experienced IDC engineers who present the workshops and keep up-to-date with consultancy work.

Concepts that are important and useful to the engineer, scientist and technician, independent of discipline, are covered in this useful booklet.

Although IDC Technologies was founded in Western Australia in 1986, it now draws engineers from all countries. IDC Technologies currently has offices in Australia, Canada, Ireland, Malaysia, New Zealand, Singapore, South Africa, UK and USA.

*We have produced this booklet so that you will get an in-depth, practical coverage of Communications, LANs and TCP/IP topics. Information at an advanced level can be gained from attendance at one of IDC Technologies Practical Training Workshops. Held across the globe, these workshops will sharpen your skills in today's competitive engineering environment.*

Other books in this series	
INSTRUMENTATION	Automation using PLCs, SCADA and Telemetry, Process Control and Data Acquisition
COMMUNICATIONS	Data Communications, Industrial Networking, TCP/IP and Fiber Optics
ELECTRONICS	Personal Computers, Digital Signal Processing and Analog/Digital Conversions
FORMULAE & CONVERSIONS	Electrical & Electronics Engineering, Mechanical Engineering, Thermodynamics, Fluid Mechanics, General Mathematics
INDUSTRIAL AUTOMATION	Process Control, Instruments and Valves, Industrial Data Comms, HAZOPS, Safety Instrumentation, Hazardous Areas, SCADA and PLCs

# 1 Power Quality

This chapter is broken down into:

- Basic Definitions
- Recommended Design and Installation Practices
- Zero Signal Reference Grid

## 1.1 Basic Definitions

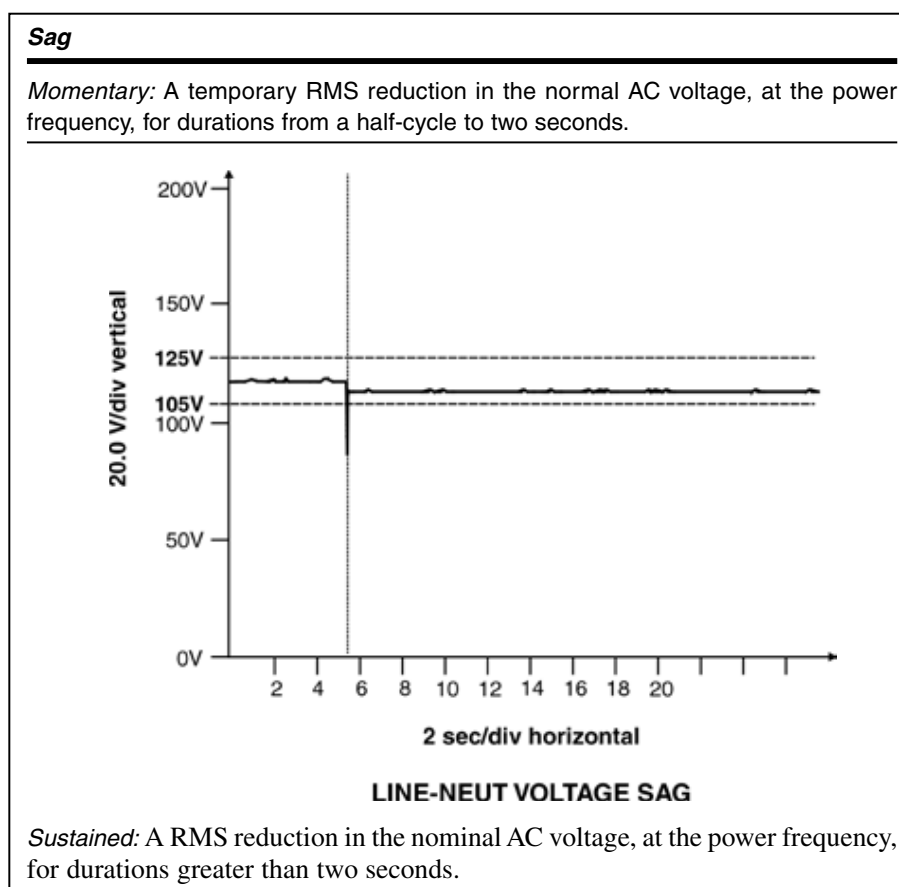

Figure 1.1 Sag



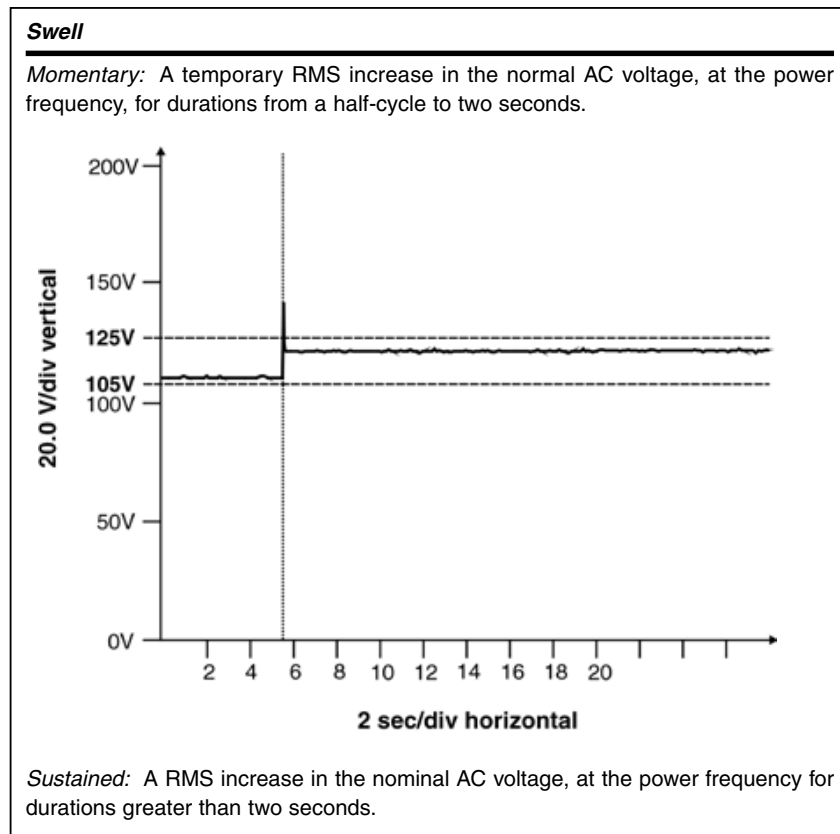
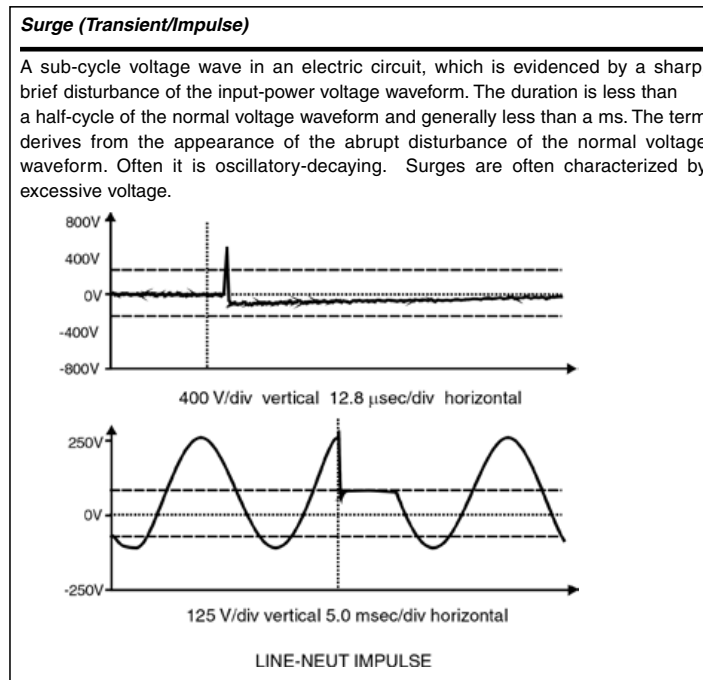

Figure 1.2 Swell

The picture of a momentary and sustained sag (remember that the sagging definition is a slow, average decrease in voltage) is showing the RMS. This is the reduction by means of the line to neutral voltage sag as experienced by a BMI type of power disturbance analyzer. The opposite of sagging, the new terminology now for the slow, average increase of voltage or temporary increase, is swelling.

## 1.2 Surges and Transients



**Figure 1.3** Surge/Transient

What we used to call transients, spikes or impulses are now formally known as surges. This is the change that took place in the definitions chapter which is affecting all the IEEE definitions throughout their publications. Figure 1.3 is of a very abrupt subcycle type of disturbance, a very brief and very steep wave front. It shows the line to neutral impulse first taking place on a very short millisecond trace at the bottom of the page and then taking place on a microsecond per division so that the centre of the bottom trace is now expanded to 128 microseconds from left to right on the upper trace. Now we get to see what that actual peak is, something far different from what we see on the bottom where we notice that there is somewhere in the neighbourhood of 600 volts of impulse now known by the term surge.

### 1.3 Harmonics and Distortions

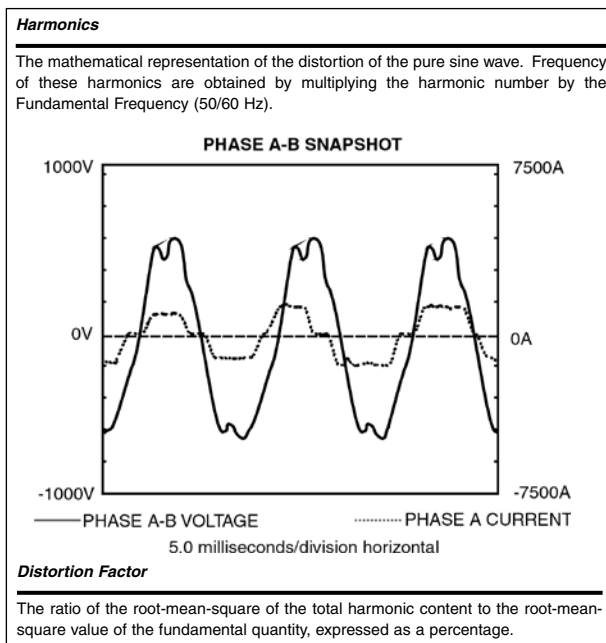

Figure 1.4 Harmonics/Distortion Factor

### 1.4 Interruptions

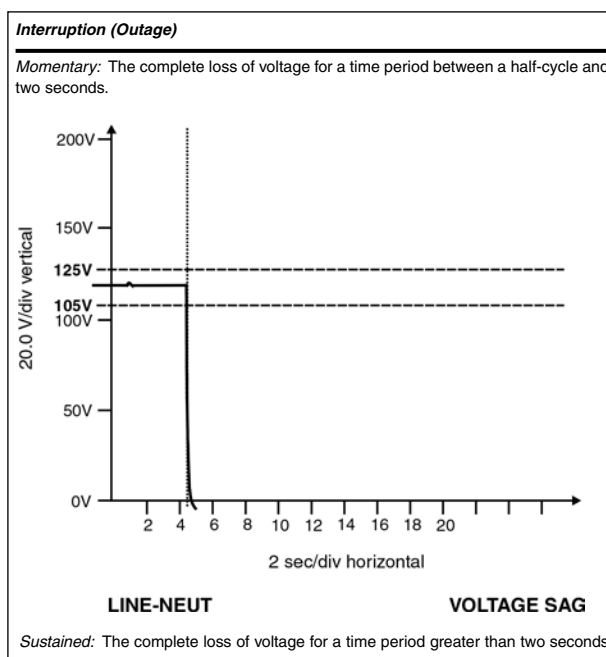

Figure 1.5 Interruption - Momentary/Sustained

Figure 1.5 speaks for itself. Obviously, the momentary loss for something having a half cycle up to two seconds worth of duration and then the definition of having a complete loss would be that power interruption that takes place over a two second long period.

### 1.5 Noise Disturbances

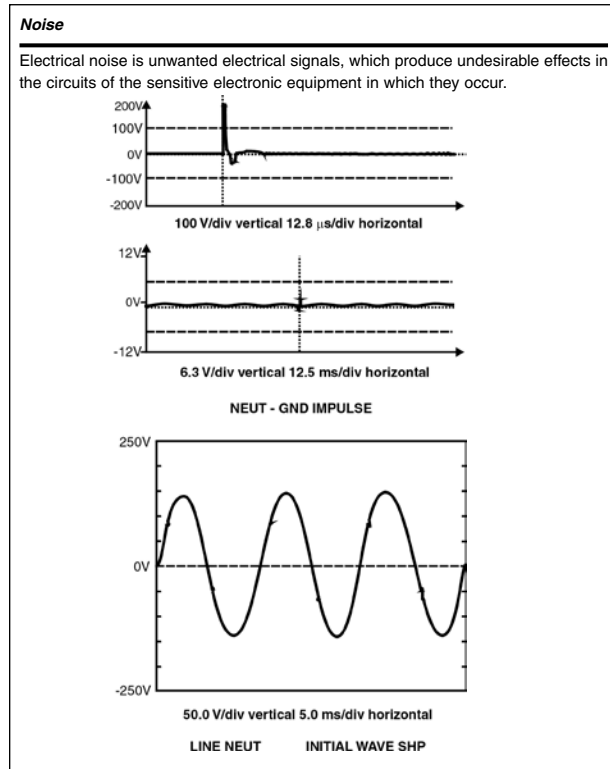

Figure 1.6 Noise

Electrical noise is shown in a variety of ways by the graphs in Figure 1.6. The undesirable effect on the circuits that serve sensitive electronic equipment are shown here. These are neutral to ground impulses, as they used to be called; but which we now call a transient surge.

## 1.6 Notching

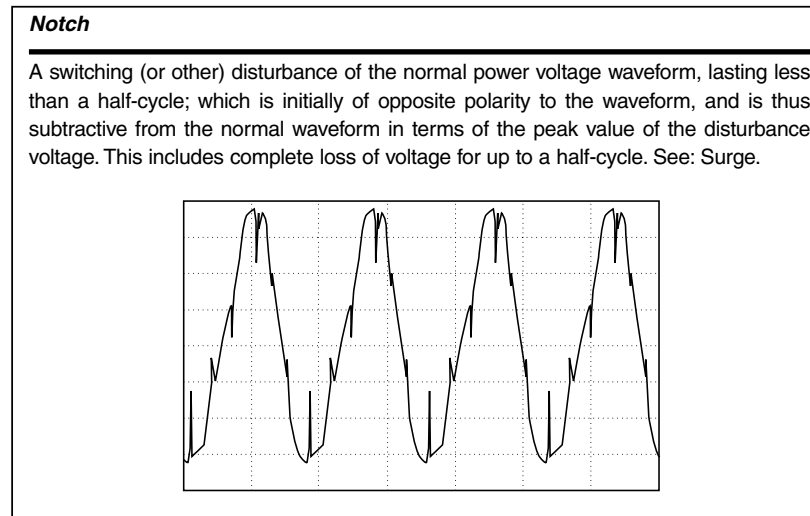

Figure 1.7 Notch

Our next definition is that for an electrical notch, which is a switching or other type of disturbance in the voltage waveform, having a particular duration and having a particular polarity and depth. The picture, as we will see, is a look at the harmonics influence of particularly the influence of the silicon control rectifiers as they switch from one step to another where two phases appear to go to 0 V and create a depression of the voltage wave shape; sometimes even the complete loss for up to a half cycle.

Please click the advert



360°  
thinking.

**Deloitte.**

Discover the truth at [www.deloitte.ca/careers](http://www.deloitte.ca/careers)

© Deloitte & Touche LLP and affiliated entities.

### 1.7 Noise Definitions

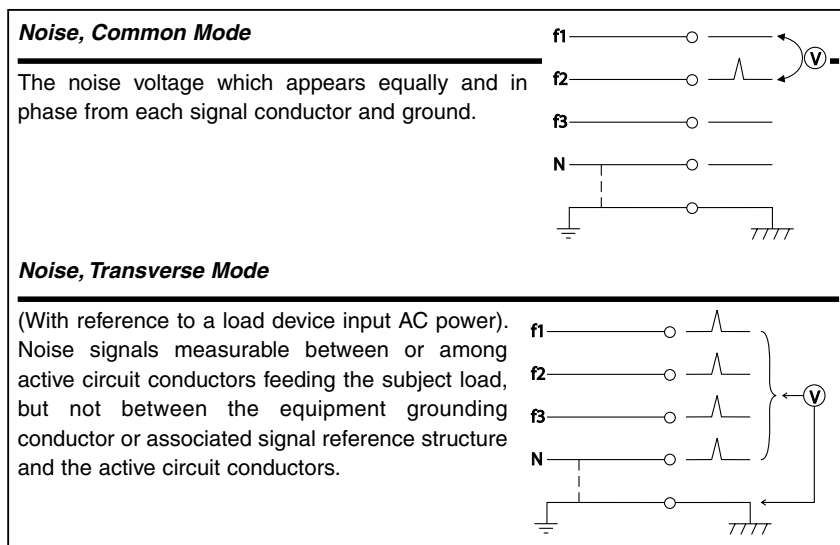

Figure 1.8 Noise - Common Mode/Transverse Mode

In our electrical noise definitions we have the definition for common mode noise and the definition for transverse mode noise. The common mode noise is more of what we might call the mystery noise circulating in the building where the noise appears between the wires, either the neutral wire or the power phase wire and ground reference.

This noise is not visible between the phase wires themselves or phase to neutral conditions as we will see later on in our explanations. But rather noise that is seeking to find the common conductor, the ground or earthing conductor that we would have in our wiring. By complement, the transverse noise is the other type of noise. Noise that is not so much a mystery. Noise that we will see occurring in the various types of disturbances from line to line or line to neutral as it is wired in the power circuit. The transverse or the normal mode noise we can see with line to line measurements. The common mode noise is always going to have to be examined with respect to the earthing conductor or the earth ground.



### 1.8 Recommended Design and Installation Practices

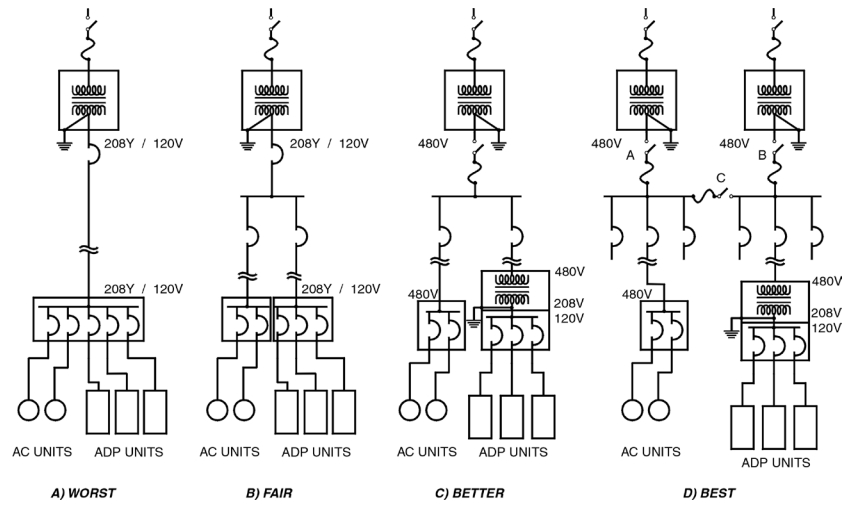

Figure 1.9 Four Wiring Diagrams

#### “Worst” Condition

Figure 1.9 takes a look at four conditions of general wiring. On the left hand side, the picture labelled “The Worst Condition” is where we have taken a single feeder from a power source. We have taken it to a remote location where there are sensitive units as well as noise producing units, such as air conditioning compressors. We have wired it to one single panel board and now we have the noise producing equipment on the same electrical bus with the noise sensitive equipment.

#### “Fair” - Slightly Better

In Figure 1.9 we have put in two panel boards on that same singular feeder separating the two types of loads by a little bit of wire. It is a fair improvement, but certainly not the only measure that should be taken.

#### “Better” - Gets the Job Done

In the picture labelled “Better” what we have done is introduced the use of the two-winding transformer to separate the sensitive equipment from a primary bus which has noise producing equipment on it. This transformer has the low internal impedance with the ability to act as a buffer for noise which is coming on the primary side. The buffer does not permit it to pass through the flexible coupling of the primary to the secondary side of the transformer.

#### “Best” - May not be Available

The picture on the far right is certainly the ultimate in design and application. It involves having multiple feeds, transfer capability and the transformer downstream of it all. It may not be possible due to electrical restrictions in a given area, financial considerations or due to space considerations to engage in the best of practices. But one thing we can concentrate on is the use of the two-winding transformer to help us with the wiring and grounding interfacing that we need between the power source and the load.

### Transformer Location

In Figure 1.10, we have the “Poor to Better” comparison of the use of the isolating transformer and some understanding of why it works so well in the way that it is laid out. You will notice in the upper example on this drawing the poor application is where the transformer is located at a considerable distance from the sensitive equipment. In this particular case the equipment is shown as being a computer powered by its own circuit breaker panel in a computer room location. The same application would hold true if it were a computer on a process floor, a computer that was running a telephone system, a network system of personnel computers or any other type of digital logic device. The reason why this application is poor is explained in the paragraph on the figure. The transformer with its grounding point is at a different location from the grounding point of the sensitive equipment in the upper picture.

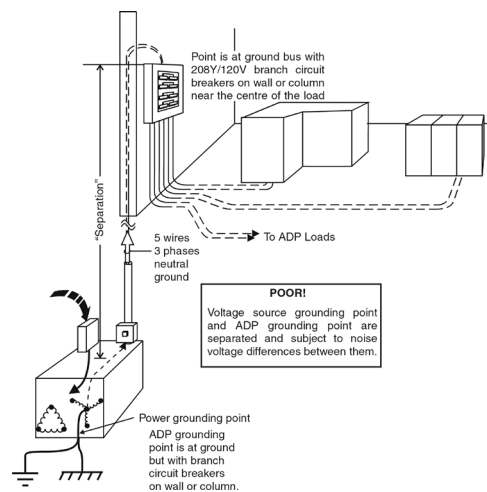

Figure 1.10 Poor and Better - Two Transformer Installation Diagrams

### 1.9 Zero Signal Reference Grid (ZSRG)

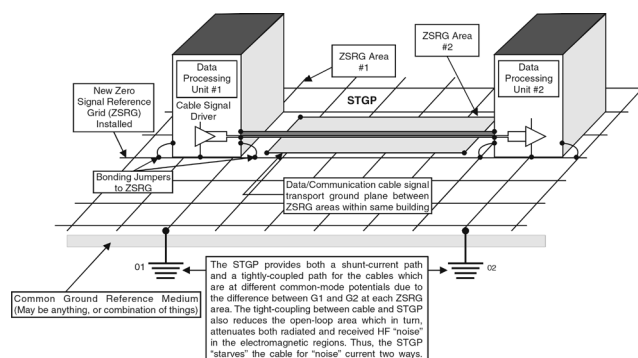

Figure 1.11 Data/Communication Signal Referencing

When two or more electronic areas are to be interconnected via metallic signal paths within the same building, the two areas should be separately constructed on their own ZSRG structures and the ZSRG structures should then be interfaced to one another via the use of metallic signal transport ground-plane constructions as shown typically in Figure 1.11.

The signal transport ground-plane is normally constructed of copper foil of about 0.010” thickness or #22 GA galvanized steel strip, and extends at least several inches to either side of the cable(s) laid directly upon it. The foil is often laid into a galvanized steel cable tray and is bonded to it frequently. This form of construction is most suitable where the cables must transit areas within a building which are separated in such a way as to make laying the foil directly upon the floor-slab impractical. This cable tray technique is especially recommended for cables that must be run either vertically or horizontally in such a manner as to place strain on the cables themselves. The tray eliminates this problem.

Cables installed upon a signal transport ground-plane are required to be laid as close to the surface of the ground-plane as is practical, so as to reduce open-loop coupling areas and to allow the electrical fields between the ground-plane and the cables to have maximum coupling via short paths. This practice significantly improves the performance of the resultant installation and provides greater immunity to externally coupled “noise” current electrical fields.

The popular practice of running metallic cables directly between electronics areas in buildings is never a good practice as it always involves problems with common-mode voltages and currents which are always to be expected. Designers should strive to eliminate the practice of directly interconnected equipment wherever possible in these cases. The use of fiber optics is clearly suggested as a better method than using metallic cables between such areas.

Please click the advert

# Grant Thornton—<sup>REALLY</sup> a great place to work.

We’re proud to have been recognized as one of Canada’s Best Workplaces by the Great Place to Work Institute™ for the last four years. In 2011 Grant Thornton LLP was ranked as the fifth Best Workplace in Canada, for companies with more than 1,000 employees. We are also very proud to be recognized as one of Canada’s top 25 Best Workplaces for Women and as one of Canada’s Top Campus Employers.



**Priyanka Sawant**  
Manager



Audit • Tax • Advisory  
[www.GrantThornton.ca/Careers](http://www.GrantThornton.ca/Careers)



© Grant Thornton LLP. A Canadian Member of Grant Thornton International Ltd

Download free ebooks at [bookboon.com](http://bookboon.com)

In the event that “noise” problems persist in a given cable(s), it is strongly suggested that a Balun transformer be used at each end of the subject cable as a means of increasing the common-mode current path’s impedance (more impedance = less current) without affecting the normal-mode signals contained within the cable. In some cases additional cable shielding may be warranted. In some cases a different form of cable driver/receiver design may be indicated. In no case, however, should the grounding system be altered as a means of trying to reduce “noise” problems if the modification either causes violation of the applicable National Electrical Code requirements or of the UL listing (safety) requirements of the subject equipment. Equipment must be either made to operate on the applicable National Electrical Code of Safety Standard acceptable wiring/grounding or it should be replaced with equipment that will operate in such an environment without the creation of safety hazards.

We notice that in data communications cable signal transport between two processing units, these two areas can be interconnected by means of one form or another of a continuous ground plane that we will call the zero signal reference grid (ZSRG). The process described here is to provide as close a coupling between the signal transport system and this common zero reference grid in order to avoid and provide immunity to externally coupled noise and electrical fields. When this is done the open loop coupling areas are made very small and the electrical fields between the ground plane and the cables will have maximum coupling via short paths and thus offer the greatest protection to the signal circuit.

# 2 Electrical Protection for Power Systems

## 2.1 The Need for Electrical Protection

It is not economically feasible to design and manufacture electrical equipment that will never fail in service. Equipment will and does fail, and the only way to limit further damage to equipment, and to restrict danger to human life, is to provide fast, reliable electrical protection. The protection of a power system detects abnormal conditions, localizes faults, and promptly removes the faulty equipment from service.

## 2.2 Protective Relays

A PROTECTIVE RELAY is the device, which operates to disconnect a faulty part of the system, thereby protecting the remainder of the system from further damage. In fact, power protection has the following five main functions as its levels of discipline and functionality, shown in order of priority.

- To ensure safety of personnel
- To safeguard the entire system
- To ensure continuity of supply
- To minimize damage
- To reduce resultant repair costs

All of these requirements make it necessary to ensure early detection, localization, and rapid isolation of electrical faults and additionally prompt and safe removal from service of faulty equipment.

## 2.3 The Basic Requirements of Protection

In order to satisfy the above requirements, protection must therefore have the following qualities:

RELIABILITY :

To operate in the pre-determined manner when an electrical fault is detected.

SELECTIVITY / DISCRIMINATION:

To detect and safely isolate only the faulty item(s).

STABILITY / SECURITY:

To leave all healthy circuits intact and undisturbed and to ensure continuity of supply.

**SENSITIVITY:**

To detect even the smallest values of fault current or system abnormalities and operate correctly at its pre-set settings.

**SPEED:**

To operate speedily when it is required thereby minimizing damage and ensuring safety to personnel.

## 2.4 Electrical Faults

Electrical faults usually occur due to breakdown of the insulating media between live conductors or between a live conductor and earth. This breakdown may be caused by any one or more of several factors, e.g. mechanical damage, overheating, voltage surges (caused by lightning or switching), ingress of a conducting medium, ionization of air, deterioration of the insulating media due to an unfriendly environment or old age, or misuse of equipment.

Fault currents release an enormous amount of thermal energy, and if not cleared quickly, may cause fire hazards, extensive damage to equipment and risk to human life.

Please click the advert

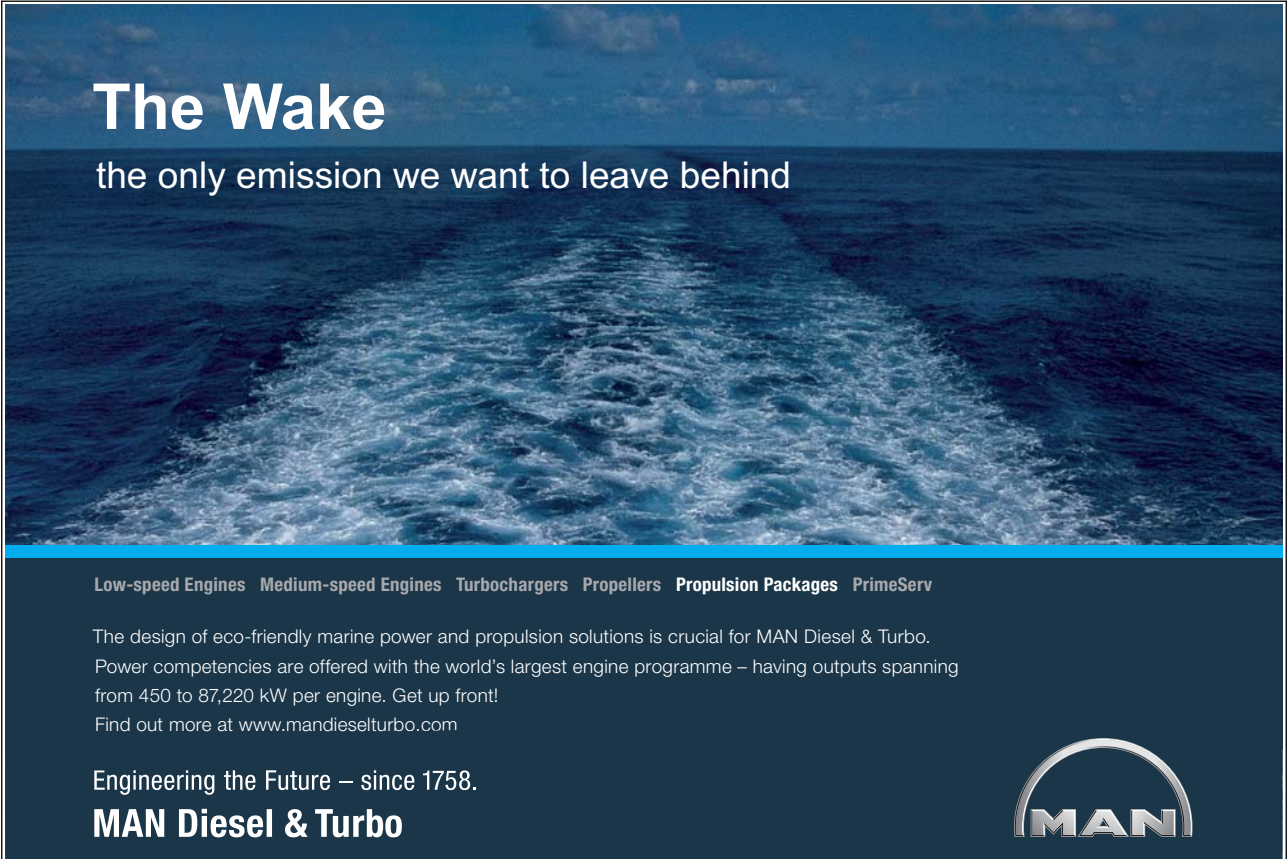

**The Wake**  
the only emission we want to leave behind

Low-speed Engines   Medium-speed Engines   Turbochargers   Propellers   Propulsion Packages   PrimeServ

The design of eco-friendly marine power and propulsion solutions is crucial for MAN Diesel & Turbo. Power competencies are offered with the world's largest engine programme – having outputs spanning from 450 to 87,220 kW per engine. Get up front!  
Find out more at [www.mandieselturbo.com](http://www.mandieselturbo.com)

Engineering the Future – since 1758.  
**MAN Diesel & Turbo**





Switchgear needs to be rated to withstand and break the worst possible fault current, which is a solid three-phase short-circuit close to the switchgear. ('Solid' meaning that there is no arc resistance. Normally arc resistance will be present, but this value is unpredictable, as it will depend on where exactly the fault occurs, the actual arcing distance, the properties of the insulating medium at that exact instance, which will be changing all the time due to the heating effect of the arc, etc. Therefore, in fault calculations, the arc resistance is ignored, as it is undeterminable, with the result that the worst case is calculated. The arc resistance will tend to decrease the fault current.

## 2.5 Transient & Permanent Faults

Transient faults are faults that do not damage the insulation permanently and as such allow the circuit to be safely re-energized after a short period of time.

A typical example would be an insulator flashover following a lightning strike, which would be successfully cleared on opening of the circuit breaker, which could then be automatically reclosed.

Transient faults occur mainly on outdoor equipment where air is the main insulating medium.

Permanent faults, as the name implies, are the result of permanent damage to the insulation of either the transmission medium or the associated equipment attached to it.

## 2.6 Calculation of Short Circuit Currents

Accurate fault current calculations are normally carried out using an analysis method called "Symmetrical Components." This method involves the use of higher mathematics and is based on the principal that any unbalanced set of vectors can be represented by a set of 3 balanced systems, namely; positive, negative and zero sequence vectors.

However, for general practical purposes it is possible to achieve a good approximation of 3 phase short circuit currents using some very simple methods, which are discussed below.

The short circuit current at the secondary side and close to the transformer, can be quickly calculated by using the following formula:

*short-circuit MVA* =

and Short - circuit current

$$I_{kA} = \frac{MVA}{\sqrt{3} \times kV}$$

where

P = Transformer rating in MVA

X% = Internal Reactance of Transformer in %

$I_{kA}$  = Short-circuit current in kA

kV = Transformer secondary voltage in kV

TYPICAL % reactance values for transformers (X%) are shown in the table below.

Primary Voltage Reactance % at MVA rating					
MVA Rating	Up to 13.8kV	25kV	36kV	69kV	138kV
0.25	3.5	4.0	4.5	5.0	6.5
0.5	4.0	4.5	5.0	5.5	6.5
1.0	5.0	5.5	5.5	6.0	7.0
2.0	5.5	6.0	6.0	6.5	7.5
3.0	6.5	6.5	6.5	7.0	8.0
5.0	7.5	7.5	7.5	8.0	8.0
>=10	10.0	10.0	10.0	10.0	10.0

**Table 2.1** Reactance Values

Normally, the % reactance value of the transformer can be obtained from the nameplate, or if not, from the transformer data sheets.

If a length of cable (more than 100m) exist between the transformer and the fault, the impedance of the cable has to be taken into account to arrive at a realistic value for the worst-case fault current. This is done by calculating the source impedance and then adding the cable impedance, as follows:

Source Impedance             $Z = \frac{kV}{\sqrt{3} \times kA}$

Fault Current kA =             $\frac{kV}{(Z_{source} + Z_{cable})}$

$Z_{cable}$  can be obtained from the manufacturer’s cable data sheets.

The above calculation is another approximation, as  $Z_{source}$  and  $Z_{cable}$  are not necessarily in phase, and complex algebra should be used. However, it is accurate enough for most practical applications.

## 2.7 Fuses

Probably the oldest, simplest, cheapest and most-often used type of protection device is the fuse. The operation of a fuse is very straightforward: The thermal energy of the excessive current causes the fuse-element to melt and the current path is interrupted. Technological developments have served to make fuses more predictable, faster and safer (not to explode).

A common misconception about a fuse, is that it will blow as soon as the current exceeds its rated value (i.e. the value stamped on the cartridge). This is far from the truth. A fuse has a typical inverse time-current characteristic, much the same as an IDMT relay. The pick-up value only starts at approximately twice the rated value, and the higher the current, the faster the fuse will blow.

By nature, fuses can only detect faults associated with excess current. Therefore, a fuse will only blow in earth fault conditions once the current in the faulty phase has increased beyond the overcurrent value. Therefore, fuses do not offer adequate earth fault protection. A fuse has only a single time-current characteristic, and cannot be adjusted. In addition, fuses need to be replaced after every operation. Finally, fuses cannot be given an external command to trip.

Fuses are very inexpensive. Therefore, they are suitable to use on less critical circuits and as back-up protection should the main protection fail, offering very reliable current-limiting features by nature.

Another advantage of fuses is the fact that they can operate totally independently, i.e. they do not need a relay with instrument transformers to tell them when to blow. This makes them especially suitable in applications like remote Ring Main Units, etc.

Please click the advert

**I WANT TO CHANGE DIRECTION,  
AND THE WORLD.**

[GOT-THE-ENERGY-TO-LEAD.COM](http://GOT-THE-ENERGY-TO-LEAD.COM)

We believe that energy suppliers should be renewable, too. We are therefore looking for enthusiastic new colleagues with plenty of ideas who want to join RWE in changing the world. Visit us online to find out what we are offering and how we are working together to ensure the energy of the future.

**RWE**  
The energy to lead

## 2.7 The Relay - Circuit-Breaker Combination

The most versatile and sophisticated type of protection available today, is undoubtedly the relay - circuit-breaker combination. The relay receives information regarding the network mainly from the instrument transformers (voltage and current transformers), detects an abnormal condition by comparing this information to pre-set values, and gives a tripping command to the circuit-breaker when such an abnormal condition has been detected. The relay may also be operated by an external tripping signal, either from other instruments, from a SCADA master, or by human intervention.

The most reliable way to provide auxiliary power to the relay is by way of a Battery Tripping Unit (BTU). The unit basically consists of a set of batteries which supplies DC power to the relay and trip circuit. The batteries are kept under charge by a battery charger, which normally is rated to have enough capacity to supply the standing load of the switchgear panel (relay auxiliary power, indication lamps, etc.). When a temporary high current is needed, usually to provide a circuit-breaker tripping supply, the batteries will supply this, and be recharged after the event. The batteries then also function as a full back up in case of total power failure.

The AC input to the BTU is usually supplied from the panel VT, or from a lighting transformer.

What often occurs in practice, and which is very bad engineering practice, is to power the relay and trip circuit directly from the panel VT. This will function correctly in most instances, but when a really severe three-phase short-circuit occurs, the voltage of the substation may drop quite dramatically, causing malfunction of the tripping circuit.

There are other ways to overcome this, like capacitive tripping circuits, and AC series tripping schemes, but each has its own disadvantages, and none are as reliable as the DC shunt tripping arrangement.

The circuit breaker opens its main contacts when the tripping signal has been received, interrupting the current.

From the protection point of view the important parts of the circuit breaker are the trip coil, latching mechanism, main contacts and auxiliary contacts.

Circuit breakers are normally fitted with a number of auxiliary contacts, which are used, as needed, in a variety of ways in control and protection circuits

Initially, circuit breakers used air as the insulating medium, later insulating oil (the oil also acting as a cooling medium), and nowadays vacuum or SF<sub>6</sub> (sulphur-hexafluoride) gas.

The connection between the relay and the circuit-breaker trip coil is purely electrical. This used to be one possible weak link in the trip circuit. One popular method to increase the reliability of the trip circuit for critical substations is to provide a full back-up trip supply. A back-up trip coil is installed in the circuit breaker, with back-up protection, powered by a second, independent BTU.

Figure 2.1 illustrates a typical arrangement.

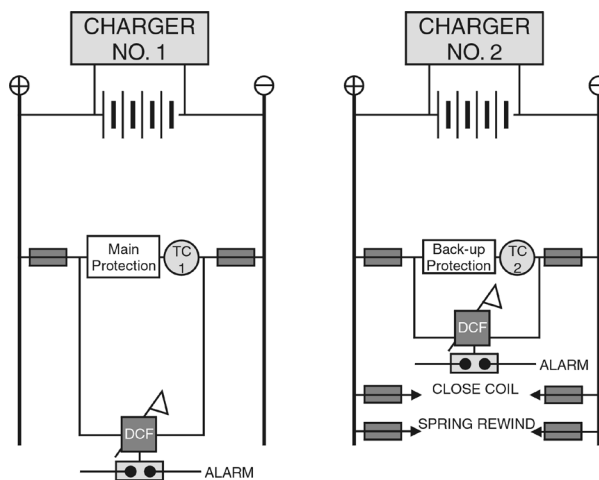

**Figure 2.1** Arrangement of D. C. Supplies with Two Trip Coils for Each Circuit Breaker

Often a second set of contacts of the same relay is used for the back-up protection, which defeats the purpose of having full redundancy somewhat, as the relay itself then forms the weakest link.

A second method of increasing the reliability of the trip circuit, is to incorporate a trip circuit supervision relay, which continually monitors the continuity of the trip circuit, and activates an alarm when an unhealthy trip circuit is detected. One shortcoming of this method is that it cannot monitor the main protection relay itself.

Modern relays now have advanced self-monitoring and trip circuit supervision functionality, activating an alarm when it detects a fault within itself or in the trip circuit, increasing reliability of the complete trip circuit tremendously.

## 2.8 Circuit Breaker Tripping Times

The first characteristic is referred to as the “TRIPPING TIME” and is expressed in cycles.

Modern high-speed circuit breakers have tripping times between 3 and 8 cycles.

The TRIPPING, TOTAL BREAK TIME is made up as follows:

- (Tripping Time) Opening Time:  
This represents the time between the instant of application of tripping power to the instant of mechanical separation of the main contacts.
- (Tripping Time) Arcing Time:  
The time between the instant of mechanical separation of the main circuit breaker contacts to the instant of arc extinction

The sum of the above: **Opening Time + Arcing Time = Breaking Time**

## 2.9 Instrument Transformers

The three main tasks of instrument transformers are

- To transform currents or voltages from a usually high value to a value easy to handle for relays and instruments.
- To insulate the relays, metering and instruments from the primary high voltage system.
- To provide possibilities of standardizing the relays and instruments etc. to a few rated currents and voltages.

## 2.10 Current Transformer (CT) Magnetization Curve

This curve is the best method of determining Current Transformer (CT) performance. It is a graph of the amount of magnetizing current required to generate an open-circuit voltage at the terminals of the unit. Due to the non-linearity of the core iron, it follows the B-H loop characteristic and comprises three regions, namely the initial region, unsaturated region and saturated region.

Please click the advert



You're full of *energy*  
and *ideas*. And that's  
just what we are looking for.

Looking for a career where your ideas could really make a difference? UBS's Graduate Programme and internships are a chance for you to experience for yourself what it's like to be part of a global team that rewards your input and believes in succeeding together.

Wherever you are in your academic career, make your future a part of ours by visiting [www.ubs.com/graduates](http://www.ubs.com/graduates).

[www.ubs.com/graduates](http://www.ubs.com/graduates)



© UBS 2010. All rights reserved.



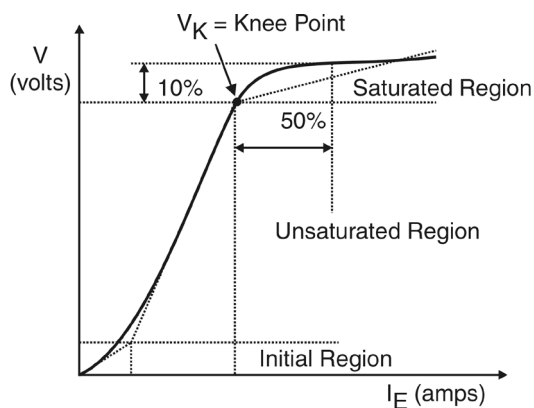

Figure 2.2 Typical CT Magnetization Curve.

### 2.11 Knee-Point Voltage

The transition from the unsaturated to the saturated region of the open circuit excitation characteristic is a rather gradual process in most core materials. It is difficult to define this transition and use is made of the so-called “knee-point” voltage for this purpose.

It is generally defined as the voltage at which a further 10% increase in volts will require a 50% increase in excitation current. For most applications, it means that current transformers can be considered as approximately linear up to this point.

### 2.12 Metering CTs

Instruments and meters are required to work accurately up to full load current, but above this it is advantageous to saturate to protect the instruments under fault conditions. They therefore have a very sharp knee-point and a special nickel-alloy metal is used, having a very low magnetizing current, in order to achieve the accuracy.

### 2.13 Protection CTs

Protective gear, on the other hand, is concerned with a wide range of currents from fault settings to maximum fault currents many times normal rating. Larger errors may be permitted and it is important to ensure that saturation is avoided wherever possible to ensure positive operation of the relays.

### 2.14 Open Circuiting of CTs

Current transformers generally work at a low flux density. The core is usually made of very good metal to give a small magnetizing current. When it is open circuit the secondary impedance now becomes infinite and the core deeply saturates.

-\*- Flashover will then occur -\*-

NEVER OPEN-CIRCUIT A C.T. ON LOAD!

As all of the primary current now becomes magnetizing current.

As the ac wave then moves from positive half cycle to the negative half cycle, the rate of change of flux  $d\phi/dt$  is so great that very high voltages are induced in the secondary winding.

## 2.15 CT Specification

A current transformer is normally specified in terms of

- A rated burden at rated current.
- An accuracy class.
- An upper limit beyond which accuracy is not guaranteed.  
(Known as the Accuracy Limit Factor, ALF).

## 2.16 Special (Class X) Current Transformers

These are normally specified for special purpose applications such as differential protection, where it is important that CTs have matching characteristics.

For this type of CT an exact point on the Magnetization Curve is specified, e.g.

- Rated primary current
- Turns ratio
- Rated knee point e.m.f. at maximum secondary turns
- Maximum exciting current at rated knee point e.m.f.
- Maximum resistance of secondary winding.

In addition, the error in the turn's ratio shall not exceed  $\pm 0.25\%$ .

## 2.17 Voltage Transformers

There are two types of voltage transformer used for protection equipment, the purely electro-magnetic type (commonly referred to as a VT) and the Capacitor type (referred to as a CVT).

### Magnetic Voltage Transformer

The magnetic voltage transformer is similar to a power transformer and differs only in so far as a different emphasis is placed on cooling, insulating and mechanical aspects.

The primary winding has a large number of turns and is connected across the line voltage either line-to-line or line-to-neutral.

The secondary has fewer turns, consequently as the volts per turn remains constant, then less voltage and higher currents are obtained.

Output burdens of 500 VA per phase are common.

### Capacitive Transformer

The capacitor VT is more commonly used on high voltage networks. The capacitor allows the injection of a high frequency signal onto the power line conductors to provide end-to-end communications between substations for distance relays telemetry/supervisory and voice communications.

## 2.18 IDMT Relays

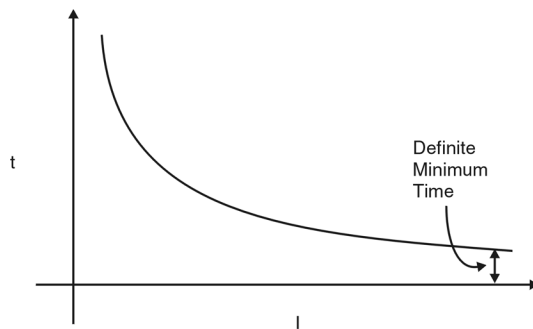

Figure 2.3 IDMT Relays

It can be seen that the operating time of an IDMT relay is inversely proportional to a function of current, i.e. it has a long operating time at low multiples of setting current and a relatively short operating time at high multiples of setting current.

Please click the advert



# CAREER **KICKSTART**

An app to keep you in the know

Whether you're a graduate, school leaver or student, it's a difficult time to start your career. So here at RBS, we're providing a helping hand with our new Facebook app. Bringing together the most relevant and useful careers information, we've created a one-stop shop designed to help you get on the career ladder – whatever your level of education, degree subject or work experience.

And it's not just finance-focused either. That's because it's not about us. It's about you. So download the app and you'll get everything you need to know to kickstart your career.

So what are you waiting for?

Click [here](#) to get started.

Two adjustments are possible on the relay, namely:

**Current (Tap) Setting**

This setting determines the level of current at which the relay will pick-up or start. Increasing this value will move the IDMT curve to the right of the graph.

**Time Dial Setting**

This setting speeds up the tripping time of the relay, and has the effect of moving the inverse curve down the axis as follows:

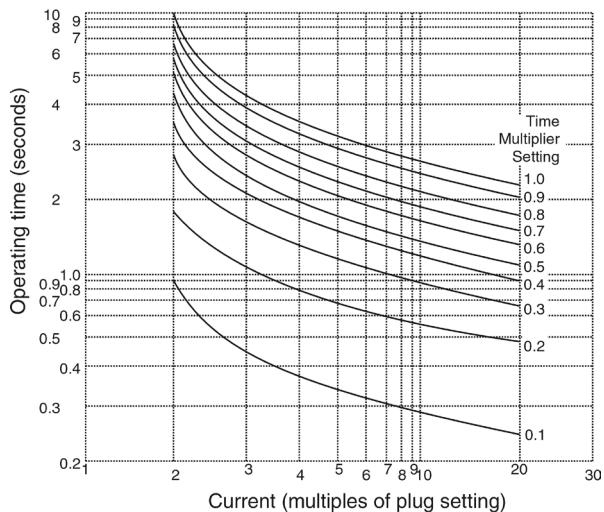

**Figure 2.4** Time/Current Characteristic.

Other characteristic curves are also available, namely VERY INVERSE and EXTREMELY INVERSE. The time curves are shown as follows:

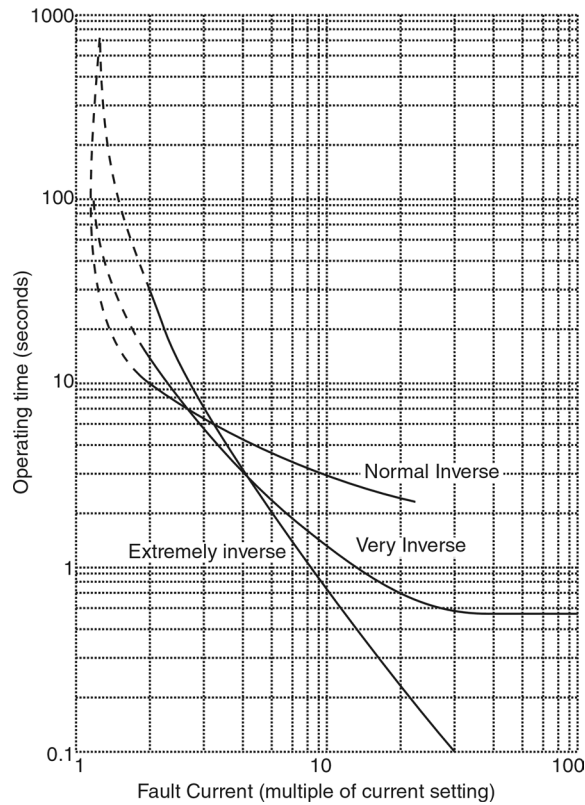

**Figure 2.5** Example of Different Inverse Curves

### 2.19 Why IDMT?

To achieve selectivity and co-ordination by time grading two philosophies are available, namely:

- Definite Time Lag (DTL), or
- Inverse Definite Minimum Time (IDMT)

For the first option, the relays are graded using a definite time interval of approximately 0.5 seconds. The relay A at the extremity of the network is set to operate in the fastest possible time, whilst its upstream relay B is set 0.5 seconds higher. Relay operating times increase sequentially at 0.5-second intervals on each section moving back towards the source as shown in Figure 2.6.

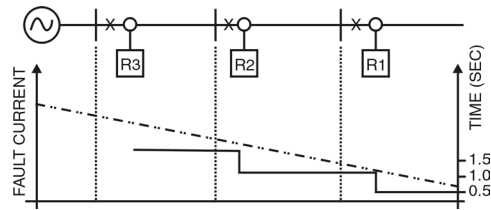

Figure 2.6 Definite Time Philosophy.

The problem with this philosophy is the closer the fault to the source, the higher the fault current, the slower the clearing time - exactly the opposite to what we should be trying to achieve!

On the other hand, inverse curves as shown in Figure 2.7 operate faster at higher fault currents and slower at the lower fault currents, thereby offering us the features that we desire.

Please click the advert

**ORACLE®**

**Be BRAVE**  
**enough to reach for the sky**

Oracle's business is information - how to manage it, use it, share it, protect it. Oracle is the name behind most of today's most innovative and successful organisations.

Oracle continuously offers international opportunities to top-level graduates, mainly in our Sales, Consulting and Support teams.

If you want to join a company that will invest in your future, Oracle is the company for you to drive your career!

<https://campus.oracle.com>



**ORACLE®**

**ORACLE IS THE INFORMATION COMPANY**

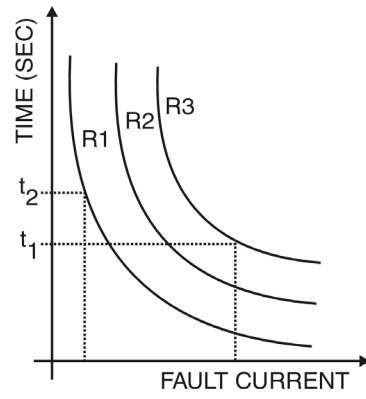

**Figure 2.7** Inverse Definite Minimum Time.

This explains why the IDMT philosophy has become standard practice throughout many countries over the years.

# 3 Substation Automation

## 3.1 Definition of the Term

Substation Automation can be defined as a system for managing, controlling and protecting a power system. This is accomplished by obtaining real-time information from the system, having powerful local and remote control applications and advanced electrical protection. The core ingredients of a Substation Automation system are local intelligence, data communications and supervisory control and monitoring.

The term Substation Automation is actually too restrictive and may be misleading. It is too restrictive in the sense that it refers specifically to a substation only. However, the concepts encompassed in the definition have a much wider application than being limited only to substations. It is applicable to electrical power networks at large, from High Voltage transmission networks, to Medium Voltage distribution networks, to Low Voltage reticulation networks.

The term may be misleading in that automation usually refers to some type of process automation, whereas the concepts involved in Substation Automation are quite unique and far removed from process automation, although there is some common ground in the underlying principles.

The term Substation Automation evolved due to the fact that most of the equipment that forms the core of such a system, is located in an electrical substation or switchroom, and these modern, intelligent devices ensure that the need for human presence or intervention in a substation is limited. The components of a Substation Automation system aim to protect, monitor and control a typical electrical substation.

Therefore the term Substation Automation is probably as descriptive as any other, and due to the fact that it already became virtually an international accepted term for the multitude of concepts involved, it is the term that will be used throughout the text.



(Note: The term “substation” will be used throughout the text to describe mainly a building housing electrical switchgear, but it may also include switchgear housed in some sort of enclosure, for example a stand-alone Ring Main Unit, etc.)

### 3.2 What is Substation Automation?

Substation Automation may be best described by referring to Figure 3.1.

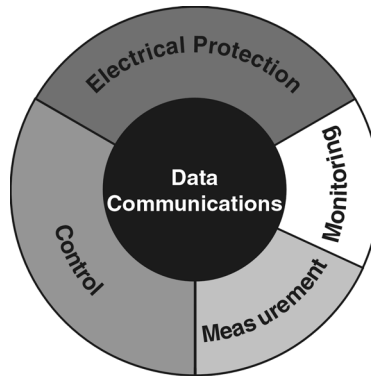

**Figure 3.1** Functional Structure of Substation Automation

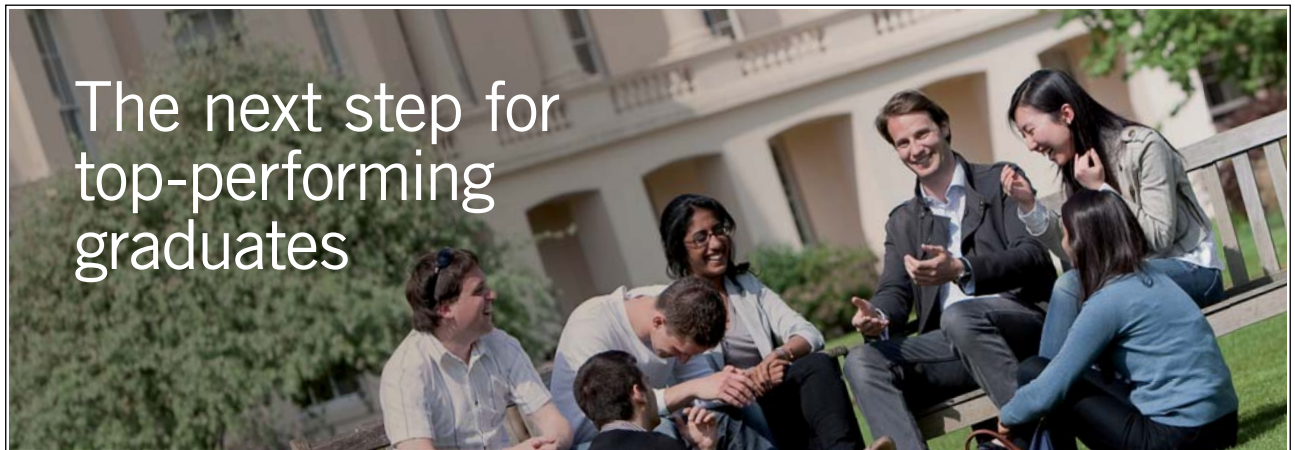

The next step for  
top-performing  
graduates

Please click the advert

#### Masters in Management

Designed for high-achieving graduates across all disciplines, London Business School’s Masters in Management provides specific and tangible foundations for a successful career in business.

This 12-month, full-time programme is a business qualification with impact. In 2010, our MiM employment rate was 95% within 3 months of graduation\*; the majority of graduates choosing to work in consulting or financial services.

As well as a renowned qualification from a world-class business school, you also gain access to the School’s network of more than 34,000 global alumni – a community that offers support and opportunities throughout your career.

For more information visit [www.london.edu/mm](http://www.london.edu/mm), email [mim@london.edu](mailto:mim@london.edu) or give us a call on **+44 (0)20 7000 7573**.

\* Figures taken from London Business School’s Masters in Management 2010 employment report



Substation Automation, by definition, consists of the following main components:

- Electrical Protection
- Control
- Measurement
- Monitoring
- Data Communications

### 3.3 Electrical Protection

Electrical Protection is still one of the most important components of any electrical switchgear panel, in order to protect the equipment and personnel, and to limit damage in case of an electrical fault.

Electrical protection is a local function, and should be able to function independently of the Substation Automation system if necessary, although it is an integral part of Substation Automation under normal conditions. The functions of electrical protection should never be compromised or restricted in any Substation Automation system.

### 3.4 Control

Control includes local and remote control. Local control consists of actions the control device can logically take by itself, for example bay interlocking, switching sequences and synchronising check. Human intervention is limited and the risk of human error is greatly reduced.

Local control should also continue to function even without the support of the rest of the Substation Automation system.

Commands can be given directly to the remote controlled devices, for example open or close a circuit breaker. Relay settings can be changed via the system, and requests for certain information can be initiated from the SCADA station(s). This eliminates the need for personnel to go to the substation to perform switching operations, and switching actions can be performed much faster, which is a tremendous advantage in emergency situations.

A safer working environment is created for personnel, and huge production losses may be prevented. In addition, the operator or engineer at the SCADA terminal has a holistic overview of what is happening in the power network throughout the plant or factory, improving the quality of decision-making.

### 3.5 Measurement

A wealth of real-time information about a substation or switchgear panel is collected, which are typically displayed in a central control room and/or stored in a central database. Measurement consists of:

- Electrical measurements (including metering) - voltages, currents, power, power factor, harmonics, etc.
- Other analog measurements, eg. transformer and motor temperatures
- Disturbance recordings for fault analyzes

This makes it unnecessary for personnel to go to a substation to collect information, again creating a safer work environment and cutting down on personnel workloads. The huge amount of real-time information collected can assist tremendously in doing network studies like load flow analyzes, planning ahead and preventing major disturbances in the power network, causing huge production losses.

**Note:**

The term ‘measurement’ is normally used in the electrical environment to refer to voltage, current and frequency, while ‘metering’ is used to refer to power, reactive power, and energy (kWh). The different terms originated due to the fact that very different instruments were historically used for measurement and metering. Nowadays the two functions are integrated in modern devices, with no real distinction between them, hence the terms ‘measurement’ and ‘metering’ are used interchangeably in the text. Accurate metering for billing purposes is still performed by dedicated instruments.

### 3.6 Monitoring

- Sequence-of-Event Recordings
- Status and condition monitoring, including maintenance information, relay settings, etc.

This information can assist in fault analyzes, determining what happened when, where and in what sequence. This can be used effectively to improve the efficiency of the power system and the protection. Preventative maintenance procedures can be utilized by the condition monitoring information obtained.

### 3.7 Data Communication

Data communication forms the core of any Substation Automation system, and is virtually the glue that holds the system together. Without communications, the functions of the electrical protection and local control will continue, and the local device may store some data, but there can be no complete Substation Automation system functioning. The form of communications will depend on the architecture used, and the architecture may, in turn, depend on the form of communication chosen.

### 3.8 Substation Automation Architecture

Different architectures exist today to implement the components of Substation Automation in practice. It is important to realize that not one single layout can exclusively illustrate a Substation Automation system. However, the most advanced systems today are developing more and more towards a common basic architecture. This architecture is illustrated in Figure 3.2.

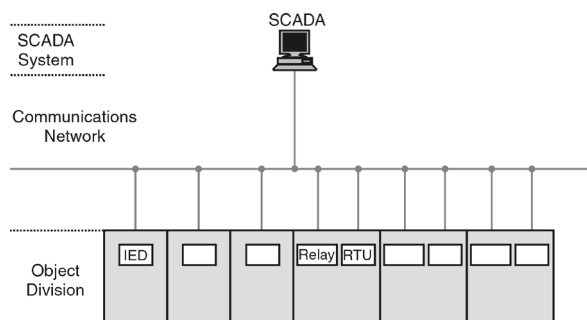

Figure 3.2 Basic Architecture of Substation Automation

### 3.9 The modern system consists of three main divisions:

#### Object Division

The object division of the Substation Automation system consists of Intelligent Electronic Devices (IEDs), modern, 3rd generation microprocessor based relays and/or Remote Terminal Units (RTUs). (PLCs also continue to play an important role in some systems.) They receive analog inputs from the Current Transformers (CTs), Voltage Transformers (VTs) and transducers in the various switchgear panels, as well as digital inputs from auxiliary contacts, other field devices or IEDs, or the SCADA Master. They are able to perform complex logical and mathematical calculations and provide an output either to the SCADA Master, other field instruments or IEDs, or back to the switchgear to perform some command, for example open a circuit breaker.

Please click the advert

# Destination MMU



Manchester Metropolitan University

MMU is proud to be one of the most popular universities in the UK. Some 34,000 students from all parts of the globe select from its curricula of over 1,000 courses and qualifications.

We are based in the dynamic yet conveniently compact city of Manchester, located at the heart of a sophisticated transport network including a major international airport on the outskirts. Parts of the campus are acclaimed for their architectural style and date back over 150 years, in direct contrast to our teaching style which is thoroughly modern, innovative and forward-thinking.

MMU offers undergraduate and postgraduate courses in the following subject areas:

- Art, Design & Performance
- Computing, Engineering & Technology
- Business & Management
- Science, Environmental Studies & Geography
- Law, Education & Psychology
- Food, Hospitality, Tourism & Leisure Studies
- Humanities & Social Science



For more details or an application form please contact MMU International. email: [international@mmu.ac.uk](mailto:international@mmu.ac.uk) telephone: +44 (0)161 247 1022 [www.mmu.ac.uk/international](http://www.mmu.ac.uk/international)

The component division consists of the process level (field information from CTs, VTs, etc) and the bay level (local intelligence in the form of IEDs, RTUs, etc).

### The Communications Network

The Communications Network (comms network for short) is virtually the nervous system of Substation Automation. The comms network ensures that raw data, processed information and commands are relayed quickly, effectively and error-free among the various field instruments, IEDs and the SCADA system. The physical medium will generally be fiber-optic cables in modern networks, although some copper wiring will still exist between the various devices inside a substation.

The comms network needs to be an 'intelligent' subsystem in its own right to perform the functions required of it, and is not merely a network of fiber-optic and copper wiring.

The communication network serves as the interface between the bay level and the SCADA station level, which might be a SCADA master station in the substation itself, or remotely in a central control room.

### SCADA Master

The SCADA (Supervisory Control And Data Acquisition) master station(s) forms the virtual brain of the Substation Automation system. The SCADA master receives data and information from the field, decides what to do with it, stores it (directly or after some form of processing), and issues requests and/or commands to the remote devices. Therefore, the SCADA master is effectively in control of the complete Substation Automation system.

Nowadays, a SCADA master consists simply of an advanced, reliable PC or workstation (with its peripheral and support hardware) and a SCADA software package.

A SCADA master station may be installed in each substation of a power transmission network (station level), with all the substation SCADA stations forming part of a LAN or WAN (network level); or one SCADA master station may be directly in control of several substations, eliminating the station level.

### Communication Protocols used in Substation Automation

Some of the more popular and widely used communication protocols are listed in table 3.1, with specific reference to protocols used in Substations at present.

Protocol	Originally Used by	Speed	Access Principle	OSI Layers
MODBUS	Gould-Modicon	19.2 kb/s	Cyclic Polling	1,2,7
SPABUS	ABB (exclusively)	19.2 kb/s	Cyclic Polling	1,2,7
DNP3.0	GE Harris	19.2 kb/s	Cyclic Polling (+)	1,2,7 (+)
IEC 60870-5	All	19.2 kb/s	Cyclic Polling	1,2,7
MODBUS +	Gould-Modicon	1.2 Mb/s	Token	1,2,7
PROFIBUS	Siemens	0.5 Mb/s	Token	1,2,7
MVB	ABB	1.5 Mb/s	TDM	1,2,7 (+)
FIP	Merlin-Gerin	2.5 Mb/s	TDM	1,2,7
Ethernet + TCP/IP	All	10 Mb/s	CSMA/CD	1-7
LON	ABB (exclusively)	1.25 Mb/s	PCSMA/CD	1-7
UCA 2.0	GE Ĩ	10 Mb/s	CSMA/CD	1-7

**Table 3.1** Protocols used in Substations

### 3.10 Communications in Substation Automation

#### Configuration

The typical Substation Automation configuration is illustrated in Figure 3.3.

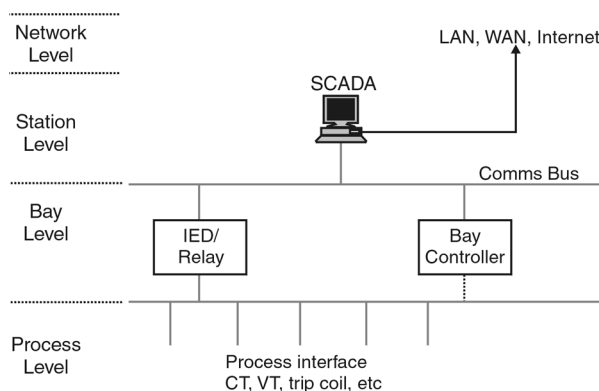

**Figure 3.3** Typical Substation Automation Structure

The Process level consists of:

- The equipment providing information to the bay level, e.g. instrument transformers, temperature sensors, auxiliary contacts of circuit breakers, etc.  
The application process is therefore a voltage, current, temperature, breaker status, etc.
- The equipment executing a command from the bay level, e.g. trip coil of circuit breaker. The application process is then the command ‘open breaker’.

The Bay level consists of four main application processes (APs): Protection, Control, Measurement/Metering, and Monitoring. These APs can reside in different devices, or all in one device (the typical IED).

The Station level consists of the Station SCADA (optional) and possibly a gateway or communications processor. The importance of the Station SCADA will depend on the specific application. In large transmission substations, this will form the main SCADA for the specific substation, with several SCADA systems forming a network. On the other hand, for a distribution substation, the Station SCADA may be dispensed with, and only a gateway will be required to connect the substation to the network and to the main SCADA.

The network level may consist of a central SCADA, to which each substation is connected, and/or a LAN, MAN, WAN or the Internet.

### Communication Requirements

The communication requirements for the various applications in substation automation will be evaluated in this section according to the following attributes:

Please click the advert



## Get Internationally Connected at the University of Surrey

**MA Intercultural Communication with International Business**  
**MA Communication and International Marketing**



#### **MA Intercultural Communication with International Business**

Provides you with a critical understanding of communication in contemporary socio-cultural contexts by combining linguistic, cultural/media studies and international business and will prepare you for a wide range of careers.

#### **MA Communication and International Marketing**

Equips you with a detailed understanding of communication in contemporary international marketing contexts to enable you to address the market needs of the international business environment.

For further information contact:

T: +44 (0)1483 681681

E: [pg-enquiries@surrey.ac.uk](mailto:pg-enquiries@surrey.ac.uk)

[www.surrey.ac.uk/downloads](http://www.surrey.ac.uk/downloads)

Download free ebooks at [bookboon.com](http://bookboon.com)

Performance	Low	Medium	High
<b>Speed / Data throughput</b>	< 10 kbps	> 10 kbps < 1 Mbps	>1 Mbps
<b>Response time</b>	> 1 s <sup>1</sup>	< 1 s > 10 ms	< 10 ms
<b>Time Synchronisation</b>	1 s	1 ms ± 0.1 ms	1 µs ± 0.5 µs
<b>Avalanche Handling</b>	No data through-put required during avalanche	Some data through-put required	All data through-put required
<b>Data Integrity</b>	Some errors allowed	Limited errors allowed	No errors allowed
<b>Link Availability</b>	All data can wait until link available	Some data can wait for a limited time	No data can wait
<b>Data Priority</b>	Can be sent after all other data	To be sent after high priority data; can wait for request	To be sent immediately; cannot wait for request

Table 3.2 Communication Requirements



# Appendix A

## Glossary of Terms

10BASE2	IEEE802.3 (or Ethernet) implementation on thin coaxial cable (RG58/AU).
10BASE5	IEEE802.3 (or Ethernet) implementation on thick coaxial cable.
10BASET	IEEE802.3 (or Ethernet) implementation on unshielded 22 AWG twisted pair cable.
A/D Conversion Time	This is the length of time a board requires to convert an analog signal into a digital value. The theoretical maximum speed (conversions/ second) is the inverse of this value. See Speed/Typical Throughput.
A/D	Analog to Digital conversion.
Absolute Addressing	A mode of addressing containing both the instruction and location(address) of data.
Accuracy	Closeness of indicated or displayed value to the idealmeasured value.
ACK	Acknowledge (ASCII - control F).
Acknowledge	A handshake line or protocol code which is used by the receiving device to indicate that it has read the transmitted data.
Active Device	Device capable of supplying current for a loop.
Active Filter	A combination of active circuit devices (usually amplifiers), with passive circuit elements (resistors and capacitors), which have characteristics that more closely match ideal filters than do passive filters.
Actuator	Control element or device used to modulate (or vary) a process parameter.
Address	A normally unique designator for location of data or the identity of a peripheral device which allows each device on a single communications line to respond to its own message.
Address Register	A register that holds the address of a location containing a data item called for by an instruction.
AFC	Automatic Frequency Control. The circuit in a radio receiver that automatically keeps the carrier frequency centred in the passband ofthe filters and demodulators.
AGC	Automatic Gain Control. The circuit in a radio that automatically keeps the carrier gain at the proper level.
Algorithm	Can be used as a basis for writing a computer program. This is a setof rules with a finite number of steps for solving a problem.
Alias Frequency	A false lower frequency component that appears in data reconstructedfrom original data acquired at an insufficient sampling rate (less than two times the maximum frequency of the original data).
ALU	see Arithmetic Logic Unit.
Amplitude Modulation	A modulation technique (also referred to as AM or ASK) used to allow data to be transmitted across an analog network, such as a switched telephone network. The amplitude of a single (carrier) frequency is varied or modulated between two levels; one for binary 0 and one for binary 1.
Analog	A continuous real-time phenomenon in which the information values are represented in a variable and continuous waveform.
Analog Input Board	Printed Circuit Board which converts incoming analog signals to digital values.
ANSI	American National Standards Institute. The principle standards development body in the USA.
Apogee	The point in an elliptical orbit that is furthest from earth.
Appletalk	A proprietary computer networking standard initiated by Apple Computer for use in connecting the Macintosh range of computers and peripherals (including Laser Writer printers).

This standard operates at 230 kilobits/second.	
Application Program	A sequence of instructions written to solve a specific problem facing organisational management.
These programs are normally written in a high-level language and	draw on resources of the operating system and the computer hardware
in executing its tasks.	
Application Layer	The highest layer of the seven layer ISO/OSI Reference Model structure, which contains all user or application programs.
Arithmetic Logic Unit	The element(s) in a processing system that perform(s) the mathematical functions such as addition, subtraction, multiplication, division, inversion, AND, OR, NAND and NOR.
ARP	Address Resolution Protocol. A Transmission Control Protocol/ Internet Protocol (TCP/IP) process that maps an IP address to Ethernet address, required by TCP/IP for use with Ethernet.
ARQ	Automatic Request for Transmission. A request by the receiver for the transmitter to retransmit a block or a frame because of errors detected in the originally received message.
AS	Australian Standard.
ASCII	American Standard Code for Information Interchange. A universal standard for encoding alphanumeric characters into 7 or 8 binary bits. Drawn up by ANSI to ensure compatibility between different computer systems.
ASIC	Application Specific Integrated Circuit.
ASK	Amplitude Shift Keying. See Amplitude Modulation.

Please click the advert

STEP INTO A WORLD OF OPPORTUNITY

www.ecco.com/trainees  
trainees@ecco.com

**ECCO**<sup>®</sup>

ASN.1	Abstract Syntax Notation One. An abstract syntax used to define the structure of the protocol data units associated with a particular protocol entity.
Asynchronous	Communications in which characters can be transmitted at an arbitrary, unsynchronised time, and where the time intervals between transmitted characters may be of varying lengths. Communication is controlled by start and stop bits at the beginning and end of each character.
Attenuation	The decrease in signal magnitude or strength between two points.
Attenuator	A passive network that decreases the amplitude of a signal (without introducing any undesirable characteristics to the signals such as distortion).
AUI CABLE	Attachment Unit Interface Cable. Sometimes called the drop cable to attach terminals to the transceiver unit.
Auto Tracking Antenna	A receiving antenna that moves in synchronism with the transmitting device which is moving (such as a vehicle being telemetered).
Autoranging	An autoranging board can be set to monitor the incoming signal and automatically select an appropriate gain level based on the previous incoming signals.
AWG	American Wire Gauge.
Background Program	An application program that can be executed whenever the facilities of the system are not needed by a higher priority program.
Backplane	A panel containing sockets into which circuit boards (such as I/O cards, memory boards and power supplies) can be plugged.
Balanced Circuit	A circuit so arranged that the impressed voltages on each conductor of the pair are equal in magnitude but opposite in polarity with respect to a defined reference.
Band Pass Filter	A filter that allows only a fixed range of frequencies to pass through. All other frequencies outside this range (or band) are sharply reduced in magnitude.
Band Reject	A circuit that rejects a defined frequency band of signals while passing all signals outside this frequency range (both lower than and higher than).
Bandwidth	The range of frequencies available, expressed as the difference between the highest and lowest frequencies, in hertz (cycles per second, abbreviated Hz).
Bar Code Symbol	An array of rectangular parallel bars and spaces of various widths designed for the labelling of objects with unique identifications. A bar code symbol contains a leading quiet zone, a start character, one or more data characters including, in some cases, a check character, a stop character, and a trailing quiet zone.
Base Address	A memory address that serves as the reference point. All other points are located by offsetting in relation to the base address.
Base Band	Base Band operation is the direct transmission of data over a transmission medium without the prior modulation on a high frequency carrier band.
Base Loading	An inductance situated near the bottom end of a vertical antenna to modify the electrical length. This aids in impedance matching.
Baud	Unit of signalling speed derived from the number of events per second (normally bits per second). However, if each event has more than one bit associated with it, the baud rate and bits per second are not equal.
Baudot	Data transmission code in which five bits represent one character. Sixty-four alphanumeric characters can be represented.
BCC	Block Check Character. Error checking scheme with one check character; a good example being Block Sum Check.
BCD	Binary Coded Decimal. A code used for representing decimal digits in a binary code.
BEL	Bell (ASCII for control-G).

BERT/BLERT	Bit Error Rate/Block Error Rate Testing. An error checking technique that compares a received data pattern with a known transmitted data pattern to determine transmission line quality.
Bifilar	Two conducting elements used in parallel (such as two parallel wires wound on a coil form).
Binary Coded Decimal	(BCD) A code used for representing decimal digits in a binary code.
BIOS	The basic input/output system for the computer, usually firmware-based. This program handles the interface with the PC hardware and isolates the Operating Software (OS) from the low-level activities of the hardware. As a result, application software becomes more independent of the particular specifications of the hardware on which it runs, and hence more portable.
Bipolar Range / Inputs	A signal range that includes both positive and negative values. Bipolar inputs are designed to accept both positive and negative voltages. (Example: $\pm 5$ V).
Bisynchronous Transmission	See BSC.
Bit Stuffing with Zero Bit Insertion	A technique used to allow pure binary data to be transmitted on a synchronous transmission line. Each message block (frame) is encapsulated between two flags which are special bit sequences. Then if the message data contains a possibly similar sequence, an additional (zero) bit is inserted into the data stream by the sender, and is subsequently removed by the receiving device. The transmission method is then said to be data transparent.
BIT (Binary Digit)	Derived from "Binary Digit", a one or zero condition in the binary system.
Bits & Bytes	One bit is one binary digit, either a binary 0 or 1. One byte is the amount of memory needed to store each character of information (text or numbers). There are eight bits to one byte (or character), and there are 1024 bytes to one kilobyte (KB). There are 1024 kilobytes to one megabyte (MB).
Block	In block-structured programming languages, a section of programming languages or a section of program coding treated as a unit.
Block Sum Check	This is used for the detection of errors when data is being transmitted. It comprises a set of binary digits (bits) which are the modulo 2 sum of the individual characters or octets in a frame (block) or message.
BNC	Bayonet type coaxial cable connector.
bps	Bits per second. Unit of data transmission rate.
Bridge	A device to connect similar sub-networks without its own network address. Used mostly to reduce the network load.
Broad Band	A communications channel that has greater bandwidth than a voice grade line and is potentially capable of greater transmission rates.
Broadcast	A message on a bus intended for all devices which requires no reply.
BS	Backspace (ASCII Control-H).
BS	British Standard.
BSC	Bisynchronous Transmission. A byte or character oriented communication protocol that has become the industry standard (created by IBM). It uses a defined set of control characters for synchronised transmission of binary coded data between stations in a data communications system.
Bubble Memory	Describes a method of storing data in memory where data is represented as magnetized spots called magnetic domains that rest on a thin film of semiconductor material. Normally used in high-vibration, high-temperature or otherwise harsh industrial environments.
Buffer	An intermediate temporary storage device used to compensate for a difference in data rate and data flow between two device (also called a spooler for interfacing a computer and a printer).

Burst Mode	A high speed data transfer in which the address of the data is sent followed by back to back data words while a physical signal is asserted.
Bus	A data path shared by many devices, with one or more conductors for transmitting signals, data or power.
Byte	A term referring to eight associated bits of information; sometimes called a "character".
Cache Memory	A fast buffer memory that fits between the CPU and the slower main memory to speed up CPU requests for data.
Capacitance (mutual)	The capacitance between two conductors with all other conductors, including shield, short circuited to the ground.
Capacitance	Storage of electrically separated charges between two plates having different potentials. The value is proportional to the surface area of the plates and inversely proportional to the distance between them.
Cascade	Two or more electrical circuits in which the output of one is fed into the input of the next one.
Cassegrain Antenna	Parabolic antenna that has a hyperbolic passive reflector situated at the focus of the parabola.
CCD	Charge-Coupled Device (camera).
CCIR	Comité Consultatif Internationale des Radiocommunications.
CCITT	Consultative Committee International Telegraph and Telephone. An international association that sets worldwide standards (e.g. V.21, V.22, V.22bis).
Cellular Polyethylene	Expanded or "foam" polyethylene consisting of individual closed cells suspended in a polyethylene medium.
CGA	Color Graphics Adapter. A computer standard utilising digital signals offering a resolution of 320 by 200 pixels and a palette of 16 colors.

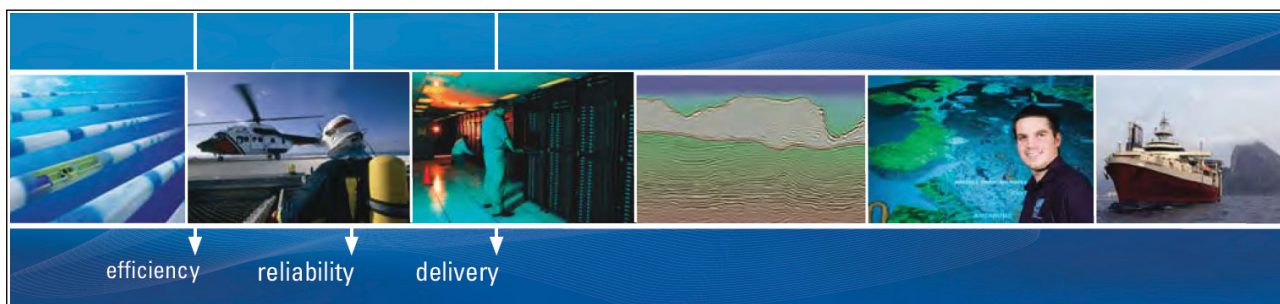

Please click the advert

As a leading technology company in the field of geophysical science, PGS can offer exciting opportunities in offshore seismic exploration.

We are looking for new BSc, MSc and PhD graduates with Geoscience, engineering and other numerate backgrounds to join us.

To learn more our career opportunities, please visit [www.pgs.com/careers](http://www.pgs.com/careers)

**A Clearer Image**  
www.pgs.com





Channel Selector	In an FM discriminator the plug-in module which causes the device to select one of the channels and demodulate the subcarrier to recover data.
Character	Letter, numeral, punctuation, control figure or any other symbol contained in a message.
Characteristic	The impedance that, when connected to the output terminals of a Impedance transmission line of any length, makes the line appear infinitely long. The ratio of voltage to current at every point along a transmission line on which there are no standing waves.
Clock	The source of timing signals for sequencing electronic events such as synchronous data transfer or CPU operation in a PC.
Clock Pulse	A rising edge, then a falling edge (in that order) such as applied to the clock input of an 8254 timer/ counter.
Clock	The source(s) of timing signals for sequencing electronic events eg synchronous data transfer.
Closed Loop	A signal path that has a forward route for the signal, a feedback network for the signal and a summing point.
CMRR	Common Mode Rejection Ratio - A data acquisition's board's ability to measure only the voltage difference between the leads of a transducer, rejecting what the leads have in common. The higher the CMRR, the better the accuracy.
CMV	Common Mode Voltage.
CNR	Carrier to Noise Ratio. An indication of the quality of the modulated signal.
Cold-junction	Thermocouple measurements can easily be affected by the interface Compensation the thermocouples are connected to. Cold-junction compensation circuitry compensates for inaccuracies introduced in the conversion process.
Collector	The voltage source in a transistor with the base as the control source and the emitter as the controlled output.
Collision	The situation when two or more LAN nodes attempt to transmit at the same time.
Common Carrier	A private data communications utility company that furnishes communications services to the general public.
Common Mode Signal	The common voltage to the two parts of a differential signal applied to a balanced circuit.
Commutator	A device used to effect time-division multiplexing by repetitive sequential switching.
Compiler	A program to convert high-level source code (such as BASIC) to machine code-executable form, suitable for the CPU.
Composite Link	The line or circuit connecting a pair of multiplexers or concentrators; the circuit carrying multiplexed data.
Composite	A video signal that contains all the intensity, color and timing information necessary for a video product.
Conical Scan Antenna	An automatic tracking antenna system in which the beam is steered in a circular path so that it forms a cone.
Contention	The facility provided by the dial network or a data PABX which allows multiple terminals to compete on a first come, first served basis for a smaller number of computer ports.
Control System	A system in which a series of measured values are used to make a decision on manipulating various parameters in the system to achieve a desired value of the original measured values.
Convolution	An image enhancement technique in which each pixel is subjected to a mathematical operation that groups it with its nearest neighbours and calculates its value accordingly.
Correlator	A device which compares two signals and indicates the similarity between the two signals.
Counter/ Timer Trigger	On-board counter/timer circuitry can be set to trigger data acquisition at a user-selectable rate and for a particular length of time.

Counter Data Register	The 8-bit register of an (8254 chip) timer/counter that corresponds to one of the two bytes in the counter's output latch for read operations and count register for write operations.
CPU	Central Processing Unit.
CR	Carriage Return (ASCII control-M).
CRC	Cyclic Redundancy Check. An error-checking mechanism using a polynomial algorithm based on the content of a message frame at the transmitter and included in a field appended to the frame. At the receiver, it is then compared with the result of the calculation that is performed by the receiver. Also referred to as CRC-16.
Cross Talk	A situation where a signal from a communications channel interferes with an associated channel's signals.
Crossed Pinning	Wiring configuration that allows two DTE or DCE devices to communicate. Essentially it involves connecting pin 2 to pin 3 of the two devices.
Crossover	In communications, a conductor which runs through the cable and connects to a different pin number at each end.
Crosstalk	A situation where a signal from a communications channel interferes with an associated channel's signals.
CSMA/CD	Carrier Sense Multiple Access/Collision Detection. When two devices transmit at the same time on a local area network, they both cease transmission and signal that a collision has occurred. Each then tries again after waiting for a random time period.
Current Sink	This is the amount of current the board can supply for digital output signals. With 10-12 mA or more of current sink capability, a board can turn relays on and off. Digital I/O boards with less than 10-12 mA of sink capability are designed for data transfer only, not for hardware power relay switching.
Current Loop	A communication method that allows data to be transmitted over a longer distance with a higher noise immunity level than with the standard RS-232C voltage method. A mark (a binary 1) is represented by current; and a space (or binary 0) is represented by the absence of current.
Current Inputs	A board rated for current inputs can accept and convert analog current levels directly, without conversion to voltage.
D/A	Digital to Analog.
DAS	Data Acquisition System.
Data Integrity	A performance measure based on the rate of undetected errors.
Data Reduction	The process of analysing a large quantity of data in order to extract some statistical summary of the underlying parameters.
Data Link Layer	This corresponds to layer 2 of the ISO Reference Model for open systems interconnection. It is concerned with the reliable transfer of data (no residual transmission errors) across the data link being used.
Data Integrity	A performance measure based on the rate of undetected errors.
Datagram	A type of service offered on a packet-switched data network. A datagram is a self contained packet of information that is sent through the network with minimum protocol overheads.
dBi	A unit that is used to represent the gain of an antenna compared to the gain of an isotropic radiator.
dBm	A signal level that is compared to a 1-mW reference.
dBmV	A signal amplitude that is compared to a 1-mV reference.
dBW	A signal amplitude that is compared to a 1-Watt reference.
DCE	Data Communications Equipment. Devices that provide the functions required to establish, maintain and terminate a data transmission connection. Normally it refers to a modem.

Decibel	A logarithmic measure of the ratio of two signal levels where $dB = 20\log_{10} V1/V2$ . Being a ratio, it has no units of measure.
Decibel (dB)	A logarithmic measure of the ratio of two signal levels where $dB = 20\log_{10} V1/V2$ or where $dB = 10\log_{10} P1/P2$ and where V refers to Voltage or P refers to Power. Note that it has no unit of measure.
Decoder	A device that converts a combination of signals into a single signal representing that combination.
Decommutator	Equipment for the demultiplexing of commutated signals.
Default	A value or setup condition assigned automatically unless another is specified.
Delay Distortion	Distortion of a signal caused by the frequency components making up the signal having different propagation velocities across a transmission medium.
DES	Data Encryption Standard.
Deviation	A movement away from a required value.
DFB	Display Frame Buffer.
Diagnostic Program	A utility program used to identify hardware and firmware defects related to the PC.
Dielectric Constant (E)	The ratio of the capacitance using the material in question as the dielectric, to the capacitance resulting when the material is replaced by air.
Differential	See Number of channels.
Digital	A signal which has definite states (normally two).
Digitize	The transformation of an analog signal to a digital signal.
DIN	Deutsches Institut Fur Normierung.
DIP	Acronym for dual in line package referring to integrated circuits and switches.
Diplexing	A device used to allow simultaneous reception or transmission of two signals on a common antenna.

Please click the advert



## Going up in the world...

You'll be going up in the world after graduating from Nottingham Trent University. We are one of the best universities in England for graduate employment with over 97% of our students employed or in further study within six months of graduating.\*

- Consistently ranked as one of the leading modern universities in *The Independent Good University Guide*.
- Courses informed by businesses and industry – strong commercial partnerships with over 6,000 companies globally.
- Many courses include professional accreditation and / or the opportunity to undertake a work placement. This gives our graduates a competitive edge when entering the job market.
- An exciting student city in the middle of England. Ideally located for travel across the UK and with direct flights to destinations across Europe from East Midlands Airport.
- Investing £130 million across our three campuses to create an inspiring learning environment.
- In the most recent QAA institutional review, the University received the highest commendation for its consistent commitment to supporting students and their learning.

If you would like any guidance on applying to Nottingham Trent University please contact Laura Vella, our International Officer for Europe, on

Tel: +44 (0)115 848 8180

Email: [laura.vella@ntu.ac.uk](mailto:laura.vella@ntu.ac.uk)

[www.ntu.ac.uk/book](http://www.ntu.ac.uk/book)

**NOTTINGHAM**  
TRENT UNIVERSITY

5365/07/09

\* HESA DHLE 2006-07



Direct Memory Access	A technique of transferring data between the computer memory and a device on the computer bus without the intervention of the micro-processor. Also abbreviated to DMA.
Discriminator	Hardware device to demodulate a frequency modulated carrier or subcarrier to produce analog data.
Dish Antenna	An antenna in which a parabolic dish acts a reflector to increase the gain of the antenna.
Dish	Concave antenna reflector for use at VHF or higher frequencies.
Diversity Reception	Two or more radio receivers connected to different antennas to improve signal quality by using two different radio signals to transfer the information.
DLE	Data Link Escape (ASCII character).
DMA	Direct Memory Access.
DNA	Distributed Network Architecture.
Doppler	The change in observed frequency of a signal caused by the emitting device moving with respect to the observing device.
Downlink	The path from a satellite to an earth station.
DPI	Dots per Inch.
DPLL	Digital Phase Locked Loop.
DR	Dynamic Range. The ratio of the full scale range (FSR) of a data converter to the smallest difference it can resolve. $DR = 2^n$ where $n$ is the resolution in bits.
DRAM	Dynamic Random Access Memory. See RAM.
Drift	A gradual movement away from the defined input/output condition over a period of time.
Driver Software	A program that acts as the interface between a higher level coding structure and the lower level hardware/firmware component of a computer.
DSP	Digital Signal Processing.
DSR	Data Set Ready. An RS-232 modem interface control signal which indicates that the terminal is ready for transmission.
DTE	Data Terminal Equipment. Devices acting as data source, data sink, or both.
Dual-ported RAM	Allows acquired data to be transferred from on-board memory to the computer's memory while data acquisition is occurring.
Duplex	The ability to send and receive data over the same communications line.
Dynamic Range	The difference in decibels between the overload or maximum and minimum discernible signal level in a system.
EBCDIC	Extended Binary Coded Decimal Interchange Code. An 8-bit character code used primarily in IBM equipment. The code allows for 256 different bit patterns.
EEPROM	Electrically Erasable Programmable Read Only Memory. This memory unit can be erased by applying an electrical signal to the EEPROM and then reprogrammed.
EGA	Enhanced Graphics Adapter. A computer display standard that provides a resolution of 640 by 350 pixels, a palette of 64 colors, and the ability to display as many as 16 colors at one time.
EIA	Electronic Industries Association. An organisation in the USA specialising in the electrical and functional characteristics of interface equipment.
EIA-232-C	Interface between DTE and DCE, employing serial binary data exchange. Typical maximum specifications are 15m at 19200 Baud.
EIA-423	Interface between DTE and DCE, employing the electrical characteristics of unbalanced voltage digital interface circuits.
EIA-449	General purpose 37 pin and 9 pin interface for DCE and DTE employing serial binary interchange.

EIA-485	The recommended standard of the EIA that specifies the electrical characteristics of drivers and receivers for use in balanced digital multipoint systems.
EIRP	Effective Isotropic Radiated Power. The effective power radiated from a transmitting antenna when an isotropic radiator is used to determine the gain of the antenna.
EISA	Enhanced Industry Standard Architecture.
EMI/RFI	Electro-Magnetic Interference or Radio Frequency Interference. Background 'noise' capable of modifying or destroying data transmission.
EMS	Expanded Memory Specification.
Emulation	The imitation of a computer system performed by a combination of hardware and software that allows programs to run between incompatible systems.
Enabling	The activation of a function of a device by a defined signal.
Encoder	A circuit which changes a given signal into a coded combination for purposes of optimum transmission of the signal.
ENQ	Enquiry (ASCII Control-E).
EOT	End of Transmission (ASCII Control-D).
EPROM	Erasable Programmable Read Only Memory. Non-volatile semiconductor memory that is erasable in a ultra violet light and reprogrammable.
Equalizer	The device which compensates for the unequal gain characteristic of the signal received.
Error Rate	The ratio of the average number of bits that will be corrupted to the total number of bits that are transmitted for a data link or system.
Error	The difference between the setpoint and the measured value.
ESC	Escape (ASCII character).
ESD	Electrostatic Discharge.
Ethernet	Name of a widely used Local Area Network (LAN), based on the CSMA/CD bus access method (IEEE 802.3).
ETX	End of Text (ASCII control-C).
Even Parity	A data verification method normally implemented in hardware in which each character (and the parity bit) must have an even number of ON bits.
External Pulse Trigger	Many of the A/D boards allow sampling to be triggered by a voltage pulse from an external source.
Fan In	The load placed on a signal line by a logic circuit input.
Fan Out	The measure of drive capability of a logic circuit output.
Farad	Unit of capacitance whereby a charge of one coulomb produces a one volt potential difference.
FCC	Federal Communications Commission (USA).
FCS	Frame Check Sequence. A general term given to the additional bits appended to a transmitted frame or message by the source to enable the receiver to detect possible transmission errors.
FDM	Frequency Division Multiplexer. A device that divides the available transmission frequency range in narrower bands, each of which is used for a separate channel.
Feedback	A part of the output signal being fed back to the input of the amplifier circuit.
Field	One half of a video image (frame) consisting of 312.5 lines (for PAL). There are two fields in a frame. Each is shown alternately every 1/25 of a second (for PAL).
FIFO	First in, First Out.
Filled Cable	A telephone cable construction in which the cable core is filled with a material that will prevent moisture from entering or passing along the cable.
FIP	Factory Instrumentation Protocol.

Firmware	A computer program or software stored permanently in PROM or ROM or semi-permanently in EPROM.
Flame Retardancy	The ability of a material not to propagate flame once the flame source is removed.
Floating	An electrical circuit that is above the earth potential.
Flow Control	The procedure for regulating the flow of data between two devices preventing the loss of data once a device's buffer has reached its capacity.
Frame	A full video image comprising two fields. A PAL frame has a total of 625 lines (an NTSC frame has 525 lines).
Frame	The unit of information transferred across a data link. Typically, there are control frames for link management and information frames for the transfer of message data.
Frame Grabber	An image processing peripheral that samples, digitizes and stores a camera frame in computer memory.
Frequency Modulation	A modulation technique (abbreviated to FM) used to allow data to be transmitted across an analog network where the frequency is varied between two levels - one for binary '0' and one for binary '1'. Also known as Frequency Shift Keying (or FSK).
Frequency	Refers to the number of cycles per second.
Frequency Domain	The displaying of electrical quantities versus frequency.
Fringing	The unwanted bordering of an object or character with weak colors when there should be a clearly delineated edge.
Full Duplex	Simultaneous two way independent transmission in both directions (4 wire). See Duplex.
G	Giga (metric system prefix - 10 <sup>9</sup> ).
Gain of Antenna	The difference in signal strengths between a given antenna and a reference isotropic antenna.

Please click the advert

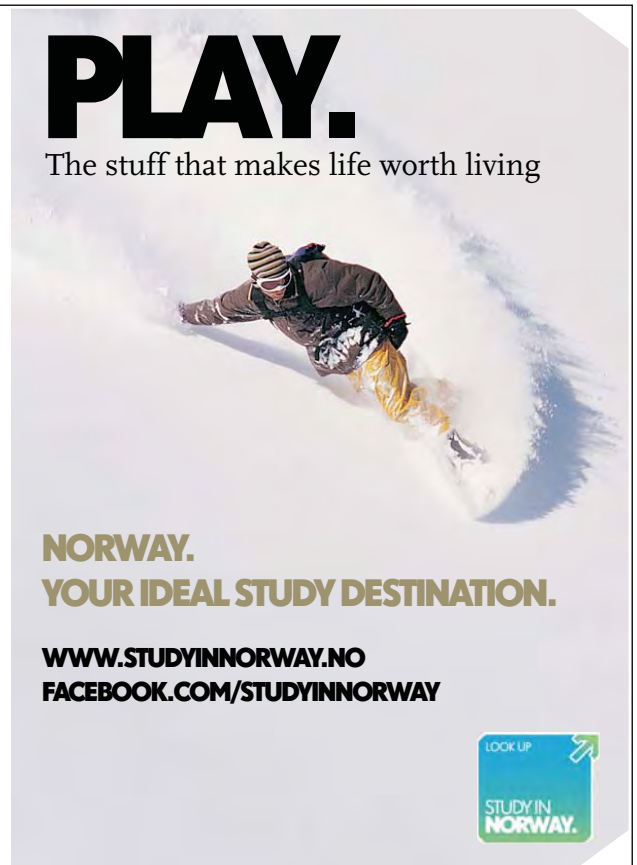
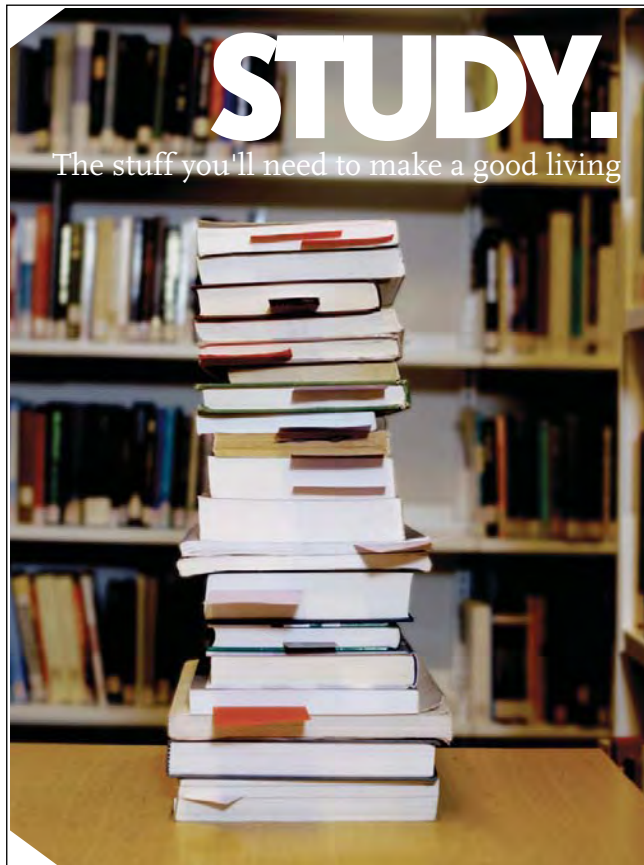

Gain	Amplification; applied to an incoming signal, gain acts as a multiplication factor on the signal, enabling a board to use signals that would otherwise be too weak. For example, when set to a gain of 10, a board with a range of +5 V can use raw input signals as low as +0.5 V (+500 mV); with a gain of 20, the range extends down to +250 mV.
Gateway	A device to connect two different networks which translates the different protocols.
Genlock	This is the process of synchronising one video signal to a master reference, ensuring that all signals will be compatible or related to one another.
Geostationary	A special earth orbit that allows a satellite to remain in a fixed position above the equator.
Geosynchronous	Any earth orbit in which the time required for one revolution of a satellite is an integral portion of a sidereal day.
GPIB	General Purpose Interface Bus. An interface standard used for parallel data communication, usually used for controlling electronic instruments from a computer. Also designated IEEE-488 standard.
Graphics Mode	In graphics mode each pixel on a display screen is addressable, and each pixel has a horizontal (or X) and a vertical (or Y) co-ordinate.
Grey Scale	In image processing, the range of available grey levels. In an 8-bit system, the grey scale contains values from 0 to 255.
Ground	An electrically neutral circuit having the same potential as the earth. A reference point for an electrical system also intended for safety purposes.
Half Duplex	Transmissions in either direction, but not simultaneously.
Half Power Point	The point in a Power versus frequency curve which is half the power level of the peak power (also called the 3dB point).
Hamming Distance	A measure of the effectiveness of error checking. The higher the Hamming Distance (HD) index, the safer is the data transmission.
Handshake Lines	Dedicated signals which allow two different devices to exchange data under asynchronous hardware control.
Handshaking	Exchange of predetermined signals between two devices establishing a connection.
Harmonic	An oscillation of a periodic quantity whose frequency is an integral multiple of the fundamental frequency. The fundamental frequency and the harmonics together form a Fourier series of the original wave form.
Harmonic Distortion	Distortion caused by the presence of harmonics in the desired signal.
HDL	High Level Data Link Control. The international standard communication protocol defined by ISO to control the exchange of data across either a point-to-point data link or a multidrop data link.
Hertz (Hz)	A term replacing cycles per second as a unit of frequency.
Hex	Hexadecimal.
Hexadecimal Number	A base 16 number system commonly used with microprocessor
HF	High Frequency.
High Pass	Generally referring to filters which allow signals above a specified frequency to pass but attenuate signals below this specified frequency.
High-Pass Filter	See HPF.
Histogram	A graphic representation of a distribution function, such as frequency, by means of rectangles whose widths represent the intervals into which the range of observed values is divided and whose heights represent the number of observations occurring in each interval.
Horn	A moderate-gain wide-beamwidth antenna.
Host	This is normally a computer belonging to a user that contains (hosts) the communication hardware and software necessary to connect the computer to a data communications network.
HPF	High-Pass Filter. A filter processing one transmission band that extends from a cutoff frequency (other than zero) to infinity.

I/O Address	A method that allows the CPU to distinguish between different boards in a system. All boards must have different addresses.
HP-IB	Hewlett-Packard Interface Bus; trade name used by Hewlett-Packard for its implementation of the IEEE-488 standard.
IEC	International Electrotechnical Commission.
IEE	Institution of Electrical Engineers.
IEEE	Institute of Electrical and Electronic Engineers. A US-based international professional society that issues its own standards and, which is a member of ANSI and ISO.
Illumination Component	An amount of source light incident on the object being viewed.
Impedance	The total opposition that a circuit offers to the flow of alternating current or any other varying current at a particular frequency. It is a combination of resistance R and reactance X, measured in ohms.
Individual Gain	A system allowing an individual gain level for each input channel, per Channel thereby allowing a much wider range of input levels and types without sacrificing accuracy on low-level signals.
Inductance	The property of a circuit or circuit element that opposes a change in current flow, thus causing current changes to lag behind voltage changes. It is measured in henrys.
Insulation Resistance (IR)	That resistance offered by an insulation to an impressed dc voltage, tending to produce a leakage current through the insulation.
Interface	A shared boundary defined by common physical interconnection characteristics, signal characteristics and measuring of interchanged signals.
Interlace	This is the display of two fields alternately with one field filling in the blank lines of the other field so that they interlock. The PAL standard displays 25 video frames per second.
Interlaced	Interlaced - describing the standard television method of raster scanning, in which the image is the product of two fields, each of which is a series of successively scanned lines separated by the equivalent of one line. Thus adjacent lines belong to different fields.
Interrupt	An external event indicating that the CPU should suspend its current task to service a designated activity.
Interrupt Handler	The section of the program that performs the necessary operation to service an interrupt when it occurs.
IP	Internet Protocol.
ISA	Industry Standard Architecture (for IBM Personal Computers).
ISA	Instrument Society of America.
ISB	Intrinsically Safe Barrier.
ISDN	Integrated Services Digital Network. A fairly recent generation of worldwide telecommunications networks that utilize digital techniques for both transmission and switching. It supports both voice and data communications.
ISO	International Standards Organisation.
Isolation	Electrical separation of two circuits. For example, optical isolation allows a high-voltage signal to be transferred to a low-voltage input without electrical interactions.
Isotropic Antenna	A reference antenna that radiates energy in all directions from a point source.
ISR	Interrupt Service Routine. See Interrupt Handler.
ITU	International Telecommunications Union.
Jabber	Garbage that is transmitted when a LAN node fails and then continuously transmits.



Jumper	A wire connecting one or more pins (on the one end of a cable only,
k (kilo)	Typically multiples of a thousand (e.g. 1 kilometer = 1000 meters) for example).
K	In computer terminology, a K is 2 <sup>10</sup> =1024. This distinguishes it from the SI unit k (kilo) which is 1000.
LAN	Local Area Network. A data communications system confined to a limited geographic area typically about 10 kms with moderate to high data rates (100kbps to 50 Mbps).  Some type of switching technology is used, but common carrier circuits are not used.
LCD	Liquid Crystal Display. A low power display system used on many laptops and other digital equipment.
LDM	Limited Distance Modem. A signal converter which conditions and boosts a digital signal so that it may be transmitted further than a standard EIA-232 signal.
Leased (or Private) Line	A private telephone line without inter-exchange switching arrangements.
LED	Light Emitting Diode. A semi-conductor light source that emits visible light or infra red radiation.
LF	Line Feed (ASCII Control-J).
Line Driver	A signal converter that conditions a signal to ensure reliable transmission over an extended distance.
Line Turnaround	The reversal of transmission direction from transmitter to receiver or vice versa when a half duplex circuit is used.
Linearity	A relationship where the output is directly proportional to the input.
Link Layer	Layer 2 of the OSI reference model; also known as the data link layer
Listener	A device on the GPIB bus that receives information from the bus.
LLC	Logical Link Control (IEEE 802.2).

Please click the advert

## Are you considering a European business degree?

**LEARN BUSINESS** at university level. We mix cases with cutting edge research working individually or in teams and everyone speaks English. Bring back valuable knowledge and experience to boost your career.

**MEET** a culture of new foods, music and traditions and a new way of studying business in a safe, clean environment – in the middle of Copenhagen, Denmark.

**ENGAGE** in extra-curricular activities such as case competitions, sports, etc. – make new friends among CBS' 18,000 students from more than 80 countries.

See what we look like and how we work on [cbs.dk](http://cbs.dk)

Loaded Line	A telephone line equipped with loading coils to add inductance in order to minimize amplitude distortion.
Long Wire	A horizontal wire antenna that is one wavelength or greater in size.
Loop Resistance	The measured resistance of two conductors forming a circuit.
Loopback	Type of diagnostic test in which the transmitted signal is returned to the sending device after passing through all, or a portion, of a data communication link or network. A loopback test permits the comparison of a returned signal with the transmitted signal.
Low Pass	Generally referring to filters which allow signals below a specified frequency to pass but attenuate a signal above this specified frequency.
Low-Pass Filter	See LPF.
LPF	Low-Pass Filter. A filter processing one transmission band, extending from zero to a specific cutoff frequency.
LSB	Least Significant Byte or Least Significant Bit.
Luminance	The black and white portion of a video signal which supplies brightness and detail for the picture.
LUT	Look-Up Table. This refers to the memory that stores the values for the point processes. Input pixel values are those for the original image whilst the output values are those displayed on the monitor as altered by the chosen point processes.
Lux	SI unit of luminous incidence of illuminance, equal to one lumen per square metre.
Lux-second	SI unit of light exposure.
m	meter. Metric system unit for length.
M	Mega. Metric system prefix for 10 <sup>6</sup> .
MAC	Media Access Control (IEEE 802).
Manchester Encoding	Digital technique (specified for the IEEE-802.3 Ethernet baseband network standard) in which each bit period is divided into two complementary halves; a negative to positive voltage transition in the middle of the bit period designates a binary "1", whilst a positive to negative transition represents a "0". The encoding technique also allows the receiving device to recover the transmitted clock from the incoming data stream (self clocking).
MAP	Manufacturing Automation Protocol. A suite of network protocols originated by General Motors which follow the seven layers of the OSI model. A reduced implementation is referred to as a mini-MAP.
Mark	This is equivalent to a binary 1.
Mask	A structure covering certain portions of a photo-sensitive medium during photographic processing.
Masking	Setting portions of an image at a constant value, either black or white. Also the process of outlining an image and then matching it to test images.
Master/Slave	Bus access method whereby the right to transmit is assigned to one device only, the Master, and all the other devices, the Slaves may only transmit when requested.
Master Oscillator	The primary oscillator for controlling a transmitter or receiver frequency. The various types are: Variable Frequency Oscillator (VFO); Variable Crystal Oscillator (VXO); Permeability Tuned Oscillator (PTO); Phase Locked Loop (PLL); Linear Master Oscillator (LMO) or frequency synthesizer.
Media Access Unit	Referred to often as MAU. This is the Ethernet transceiver unit situated on the coaxial cable which then connects to the terminal with a drop cable.
Microwave	AC signals having frequencies of 1 GHz or more.
MIPS	Million Instructions per second.

MMS	Manufacturing Message Services. A protocol entity forming part of the application layer. It is intended for use specifically in the manufacturing or process control industry. It enables a supervisory computer to control the operation of a distributed community of computer based devices.
Modem	MODulator - DEModulator. A device used to convert serial digital data from a transmitting terminal to a signal suitable for transmission over a telephone channel or to reconvert the transmitted signal to serial digital data for the receiving terminal.
Modem Eliminator	A device used to connect a local terminal and a computer port in lieu of the pair of modems to which they would ordinarily connect, allow DTE to DTE data and control signal connections otherwise not easily achieved by standard cables or connections.
Modulation Index	The ratio of the frequency deviation of the modulated wave to the frequency of the modulating signal.
Morphology	The study of a structure/form of object in an image.
MOS	Metal Oxide Semiconductor.
MOV	Metal Oxide Varistor.
MSB	Most Significant Byte or Most Significant Bit.
MTBF	Mean Time Between Failures.
MTTR	Mean Time To Repair.
Multidrop	A single communication line or bus used to connect three or more points.
Multiplexer (MUX)	A device used for division of a communication link into two or more channels, either by using frequency division or time division.
Multiplexer	A technique in which multiple signals are combined into one channel. They can then be demultiplexed back into the original components.
NAK	Negative Acknowledge (ASCII Control-U).
Narrowband	A device that can only operate over a narrow band of frequencies.
Negative True Logic	The inversion of the normal logic where the negative state is considered to be TRUE (or 1) and the positive voltage state is considered to be FALSE (or 0).
Network Layer	Layer 3 in the OSI model; the logical network entity that services the transport layer responsible for ensuring that data passed to it from the transport layer is routed and delivered throughout the network.
Network Architecture	A set of design principles including the organisation of functions and the description of data formats and procedures used as the basis for the design and implementation of a network (ISO).
Network	An interconnected group of nodes or stations.
Network Topology	The physical and logical relationship of nodes in a network; the schematic arrangement of the links and nodes of a network typically in the form of a star, ring, tree or bus topology.
NMRR	Normal Mode Rejection Ratio - The ability of a board to filter out noise from external sources, such as AC power lines. NMRR filtering compensates for transient changes in the incoming signal to provide greater accuracy. The higher the NMRR, the better the filtering of incoming data will be.
Node	A point of interconnection to a network.
Noise	A term given to the extraneous electrical signals that may be generated or picked up in a transmission line. If the noise signal is large compared with the data carrying signal, the latter may be corrupted resulting in transmission errors.
Non-linearity	A type of error in which the output from a device does not relate to the input in a linear manner.
NRZ	Non Return to Zero. Pulses in alternating directions for successive 1 bits but no change from existing signal voltage for 0 bits.



NRZI	Non Return to Zero Inverted.
NTSC	National Television System Committee (USA). A television standard specifying 525 lines and 60 fields per second.
Null Modem	A device that connects two DTE devices directly by emulating the physical connections of a DCE device.
Number of Channels	This is the number of input lines a board can sample. Single-ended inputs share the same ground connection, while differential inputs have individual two-wire inputs for each incoming signal, allowing greater accuracy and signal isolation. See also multiplexer.
Nyquist Sampling	In order to recover all the information about a specified signal it Theorem must be sampled at least at twice the maximum frequency component of the specified signal.
OCR	Optical Character Recognition, optical character reader.
ohm	Unit of resistance such that a constant current of one ampere produces a potential difference of one volt across a conductor.
OLUT	Output Look-Up Table.
On-board Memory	Incoming data is stored in on-board memory before being dumped into the PC's memory. On a high-speed board, data is acquired at a much higher rate than can be written into PC memory, so it is stored in the on-board buffer memory.
Optical Isolation	Two networks with no electrical continuity in their connection because an optoelectronic transmitter and receiver has been used.
OR	Outside Radius.
OSI	Open Systems Interconnection. A set of defined protocol layers with a standardized interface which allows equipment from different manufacturers to be connected.

Please click the advert



## Technical training on *WHAT* you need, *WHEN* you need it

**At IDC Technologies we can tailor our technical and engineering training workshops to suit your needs. We have extensive experience in training technical and engineering staff and have trained people in organisations such as General Motors, Shell, Siemens, BHP and Honeywell to name a few.**

Our onsite training is cost effective, convenient and completely customisable to the technical and engineering areas you want covered. Our workshops are all comprehensive hands-on learning experiences with ample time given to practical sessions and demonstrations. We communicate well to ensure that workshop content and timing match the knowledge, skills, and abilities of the participants.

We run onsite training all year round and hold the workshops on your premises or a venue of your choice for your convenience.

**For a no obligation proposal, contact us today at [training@idc-online.com](mailto:training@idc-online.com) or visit our website for more information: [www.idc-online.com/onsite/](http://www.idc-online.com/onsite/)**

OIL & GAS  
ENGINEERING

ELECTRONICS

AUTOMATION &  
PROCESS CONTROL

MECHANICAL  
ENGINEERING

INDUSTRIAL  
DATA COMMS

ELECTRICAL  
POWER

Phone: **+61 8 9321 1702**

Email: [training@idc-online.com](mailto:training@idc-online.com)

Website: [www.idc-online.com](http://www.idc-online.com)



Output	An analog or digital output control type signal from the PC to the external 'real world'.
Overlay	One video signal superimposed on another, as in the case of computer-generated text over a video picture.
Packet	A group of bits (including data and call control signals) transmitted as a whole on a packet switching network. Usually smaller than a transmission block.
PAD	Packet Access Device. An interface between a terminal or computer and a packet switching network.
PAL	Phase Alternating Lines. This is the television standard used in Europe and Australia. The PAL standard is 25 frames per second with 625 lines.
Parallel Transmission	The transmission model where multiple data bits are sent simultaneously over separate parallel lines. Accurate synchronisation is achieved by using a timing (strobe) signal. Parallel transmission is usually unidirectional; an example would be the Centronics interface to a printer.
Parametric Amplifier	An inverting parametric device for amplifying a signal without frequency translation from input to output.
Parasitic	Undesirable electrical parameter in a circuit such as oscillations or capacitance.
Parity Bit	A bit that is set to a "0" or "1" to ensure that the total number of 1 bits in the data and parity fields are even or odd.
Parity Check	The addition of non information bits that make up a transmission block to ensure that the total number of data and parity bits is always even (even parity) or odd (odd parity). Used to detect transmission errors but rapidly losing popularity because of its weakness in detecting errors.
Passive Filter	A circuit using only passive electronic components such as resistors, capacitors and inductors.
Passive Device	Device that must draw its power from connected equipment.
Path Loss	The signal loss between transmitting and receiving antennas.
PBX	Private Branch Exchange.
PCIP	Personal Computer Instrument Products.
PCM	Pulse Code Modulation. The sampling of a signal and encoding the amplitude of each sample into a series of uniform pulses.
PDU	Protocol Data Unit.
PEP	Peak Envelope Power. Maximum amplitude that can be achieved with any combination of signals.
Perigee	The point in an elliptical orbit that is closest to earth.
Peripherals	The input/output and data storage devices attached to a computer e.g. disk drives, printers, keyboards, display, communication boards, etc.
Phase Shift Keying	A modulation technique (also referred to as PSK) used to convert binary data into an analog form comprising a single sinusoidal frequency signal whose phase varies according to the data being transmitted.
Phase Modulation	The sine wave or carrier has its phase changed in accordance with the information to be transmitted.
Physical Layer	Layer 1 of the ISO/OSI Reference Model, concerned with the electrical and mechanical specifications of the network termination equipment.
PIA	Peripheral Interface Adapter. Also referred to as PPI (Programmable Peripheral Interface).
Pixel	One element of a digitized image, sometimes called picture element, or pel.
PLC	Programmable Logic Controller.
PLL	Phase Locked Loop
Point to Point	A connection between only two items of equipment.

Polar Orbit	The path followed when the orbital plane includes the north and south poles.
Polarisation	The direction of an electric field radiated from an antenna.
Polling	A means of controlling I/O devices on a multipoint line in which the CPU queries ('polls') the devices at regular intervals to check for data awaiting transfer (to the CPU). Slower and less efficient than interrupt driven I/O operations.
Polyethylene	A family of insulators derived from the polymerisation of ethylene gas and characterized by outstanding electrical properties, including high IR, low dielectric constant, and low dielectric loss across the frequency spectrum.
Polyvinyl Chloride	A general purpose family of insulations whose basic constituent is (PVC) polyvinyl chloride or its copolymer with vinyl acetate. Plasticisers, stabilizers, pigments and fillers are added to improve mechanical and/ or electrical properties of this material.
Port	A place of access to a device or network, used for input/output of digital and analog signals.
PPI	See PIA.
Presentation Layer	Layer 6 of the ISO/OSI Reference Model, concerned with negotiation of a suitable transfer syntax for use during an application. If this is different from the local syntax, the translation is to/from this syntax.
Pretrigger	Boards with 'pretrigger' capability keep a continuous buffer filled with data, so when the trigger conditions are met, the sample includes the data leading up to the trigger condition.
Profibus	Process Field Bus developed by a consortium of mainly German companies with the aim of standardisation.
Program I/O	The standard method of memory access, where each piece of data is assigned to a variable and stored individually by the PC's processor.
Programmable Gain	Using an amplifier chip on an A/D board, the incoming analog signal is increased by the gain multiplication factor. For example; if the input signal is in the range of -250 mV to +250 mV, the voltage after the amplifier chip set to a gain of 10 would be -2.5 V to +2.5 V.
PROM	Programmable Read Only Memory. This is programmed by the manufacturer as a fixed data or program which cannot easily be changed by the user.
Protocol Entity	The code that controls the operation of a protocol layer.
Protocol	A formal set of conventions governing the formatting, control procedures and relative timing of message exchange between two communicating systems.
PSDN	Public Switched Data Network. Any switching data communications system, such as Telex and public telephone networks, which provides circuit switching to many customers.
PSTN	Public Switched Telephone Network. This is the term used to describe the (analog) public telephone network.
PTT	Post, Telephone and Telecommunications Authority.
Public Switched Network	Any switching communications system - such as Telex and public telephone networks - that provides circuit switching to many customers.
Pulse Input	A square wave input from a real world device such as a flow meter, which sends pulses proportional to the flow rate.
QAM	Quadrature Amplitude Modulation.
QPSK	Quadrature Phase Shift Keying.
Quagi	An antenna consisting of both full wavelength loops (quad) and Yagi elements.
R/W	Read/Write.

RAM	Random Access Memory. Semiconductor read/write volatile memory. Data is lost if the power is turned off.
RAMDAC	Random Access Memory Digital-to-Analog Converter.
Range	The difference between the upper and lower limits of the measured value.
Range Select	The full-scale range a board uses is selected by one of three methods: through the appropriate software, by a hardware jumper on the board, or through the use of an external reference voltage.
Raster	The pattern of lines traced by rectilinear scanning in display systems.
Reactance	The opposition offered to the flow of alternating current by inductance or capacitance of a component or circuit.
Real-time	A system is capable of operating in real-time when it is fast enough to react to the real-world events.
Reflectance Component	The amount of light reflected by an object in the scene being viewed.
Refresh rate	The speed at which information is updated on a computer display (CRT).
Repeater	An amplifier which regenerates the signal and thus expands the network.
Resistance	The ratio of voltage to electrical current for a given circuit measured in ohms.
Resolution	The number of bits in which a digitized value will be stored. This represents the number of divisions into which the full-scale range will be divided; for example, a 0-10 V range with a 12-bit resolution will have 4096(2 <sup>12</sup> ) divisions of 2.44mV each.
Response Time	The elapsed time between the generation of the last character of a message at a terminal and the receipt of the first character of the reply. It includes terminal delay and network delay.
RF	Radio Frequency.
RFI	Radio Frequency Interference.

Please click the advert

**www.studyat.tudelft.nl**

- Ranked #15th in the world (THES Technology ranking 2009)
- Almost 170 years of problem solving experience
- Excellent Sports&Culture facilities
- Check out what and how we teach at [www.ocw.tudelft.nl](http://www.ocw.tudelft.nl) !

**TU Delft** Delft University of Technology  
 Challenge the future

RGB	Red/Green/Blue. An RGB signal has four separate elements; red/green/ blue and sync. This results in a cleaner image than with composite signals due to the lower level of distortion and interference.
Ring	Network topology commonly used for interconnection of communities of digital devices distributed over a localized area, e.g. a factory or office block. Each device is connected to its nearest neighbours until all the devices are connected in a closed loop or ring. Data are transmitted in one direction only. As each message circulates around the ring, it is read by each device connected in the ring.
Ringing	An undesirable oscillation or pulsating current.
Rise Time	The time required for a waveform to reach a specified value from
some smaller value.	
RLE	Run Length Encoder. A digital image method whereby the first grey level of each sequential point-by-point sample and its position in the succession of grey levels is encoded. It is used where there is a tendency for long runs of repeated digitized grey levels to occur.
RMS	Root Mean Square.
ROI	Region of Interest.
ROM	Read Only Memory. Computer memory in which data can be routinely read but written to only once using special means when the ROM is manufactured. A ROM is used for storing data or programs on a permanent basis.
Router	A linking device between network segments which may differ in Layers 1, 2a and 2b of the ISO/OSI Reference Model.
RS	Recommended Standard, for example, RS-232C. More recent designations use EIA, for example, EIA-232C.
RS-232C	Interface between DTE and DCE, employing serial binary data exchange. Typical maximum specifications are 50 feet (15m) at 19200 baud
RS-422	Interface between DTE and DCE, employing the electrical characteristics of balanced voltage interface circuits.
RS-423	Interface between DTE and DCE, employing the electrical characteristics of unbalanced voltage digital interface circuits.
RS-449	General purpose 37-pin and 9-pin interface for DCE and DTE employing serial binary interchange.
RS-485	The recommended standard of the EIA that specifies the electrical characteristics of drivers and receives for use in balanced digital multipoint systems.
RTU	Remote Terminal Unit. Terminal Unit situated remotely from the main control system.
S-Video	The luminance and chrominance elements of a video signal are isolated from each other, resulting in a far cleaner image with greater resolution.
SAA	Standards Association of Australia.
SAP	Service Access Point.
SDLC	Synchronous Data Link Control. IBM standard protocol superseding the bisynchronous standard.
Selectivity	A measure of the performance of a circuit in distinguishing the desired signal from those at other frequencies.
Self-calibrating	A self-calibrating board has an extremely stable on-board reference which is used to calibrate A/D and D/A circuits for higher accuracy.
Self-diagnostics	On-board diagnostic routine which tests most, if not all, of a board's functions at power-up or on request.
Serial Transmission	The most common transmission mode in which information bits are sent sequentially on a single data channel.



Session Layer	Layer 5 of the ISO/OSI Reference Model, concerned with the establishment of a logical connection between two application entities and with controlling the dialogue (message exchange) between them.
Shielding	The process of protecting an instrument or cable from external noise (or sometimes protecting the surrounding environment of the cable from signals within the cable.)
Short Haul Modem	A signal converter which conditions a digital signal to ensure reliable transmission over DC continuous private line metallic circuits, without interfering with adjacent pairs of wires in the same telephone cables.
Shutter	A mechanical or electronic device used to control the amount of time a light-sensitive material is exposed to radiation.
SI	International metric system of units (Système Internationale).
Sidebands	The frequency components which are generated when a carrier is frequency-modulated.
Upconverter	A device used to translate a modulated signal to a higher band of frequencies.
Sidereal Day	The period of an earth's rotation with respect to the stars.
Signal to Noise Ratio	The ratio of signal strength to the level of noise.
Signal Conditioning	Pre-processing of a signal to bring it up to an acceptable quality level for further processing by a more general purpose analog input system.
Simplex Transmission	Data transmission in one direction only.
Simultaneous Sampling	The ability to acquire and store multiple signals at exactly the same moment. Sample-to-sample inaccuracy is typically measured in nanoseconds.
Single-ended	See number of channels.
Slew Rate	This is defined as the rate at which the voltage changes from one value to another.
Smart Sensors	A transducer (or sensor) with an on-board microprocessor to pre-process input signals to the transducer. It also has the capability of communicating digitally back to a central control station.
SNA	Systems Network Architecture.
SNR	Signal to Noise Ratio.
Software Drivers	Typically a set of programs or subroutines allowing the user to control basic board functions, such as setup and data acquisition. These can be incorporated into user-written programs to create a simple but functional DAS system. Many boards come with drivers supplied.
Software Trigger	Software control of data acquisition triggering. Most boards are designed for software control.
SOH	Start of Header (ASCII Control-A).
Space	Absence of signal. This is equivalent to a binary zero.
Spark Test	A test designed to locate imperfections (usually pin-holes) in the insulation of a wire or cable by application of a voltage for a very short period of time while the wire is being drawn through the electrode field.
Spatial Resolution	A measure of the level of detail a vision system can display. The value, expressed in mils or inches per pixel, is derived by dividing the linear dimensions of the field of view (x and y, as measured in the image plane), by the number of pixels in the x and y dimensions of the system's imaging array or image digitizer.
Spatial Filtering	In image processing, the enhancement of an image by increasing or decreasing its spatial frequencies.
Spectral Purity	The relative quality of a signal measured by the absence of harmonics, spurious signals and noise.
Speed/Typical	The maximum rate at which the board can sample and convert

Throughput	incoming samples. The typical throughput is divided by the number of channels being sampled to arrive at the samples/second on each channel. To avoid false readings, the samples per second on each channel need to be greater than twice the frequency of the analog signal being measured.
Standing Wave Ratio	The ratio of the maximum to minimum voltage (or current) on a transmission line at least a quarter-wavelength long. (VSWR refers to voltage standing wave ratio)
Star	A type of network topology in which there is a central node that performs all switching (and hence routing) functions.
Statistical Multiplexer	Multiplexer in which data loading from multiple devices occurs randomly throughout time, in contrast to standard multiplexers where data loading occurs at regular predictable intervals.
STP	Shielded Twisted Pair.
Straight Through Pinning	EIA-232 and EIA-422 configuration that match DTE to DCE, pin for pin (pin 1 with pin 1, pin 2 with pin 2, etc).
Strobe	A handshaking line used to signal to a receiving device that there is data to be read.
STX	Start of Text (ASCII Control-B).
Subharmonic	A frequency that is a integral submultiple of a reference frequency.
Switched Line	A communication link for which the physical path may vary with each use, such as the public telephone network.
Sync	A synchronisation, or sync, pulse ensures that the monitor displaying the information is synchronized at regular intervals with the device supplying the data, thus displaying the data at the right location. For example, a sync pulse would be used between a camera and a display device to reset the image to the top of the frame for the beginning of the image.
Synchronisation	The co-ordination of the activities of several circuit elements.

Please click the advert

## Study at one of Europe's leading universities



DTU, Technical University of Denmark, is ranked as one of the best technical universities in Europe, and offers internationally recognised Master of Science degrees in 39 English-taught programmes.

DTU offers a unique environment where students have hands-on access to cutting edge facilities and work

closely under the expert supervision of top international researchers.

DTU's central campus is located just north of Copenhagen and life at the University is engaging and vibrant. At DTU, we ensure that your goals and ambitions are met. Tuition is free for EU/EEA citizens.

Visit us at [www.dtu.dk](http://www.dtu.dk)



Synchronous	Transmission in which data bits are sent at a fixed rate, with the Transmission transmitter and receiver synchronized. Synchronized transmission eliminates the need for start and stop bits.
Talker	A device on the GPIB bus that simply sends information onto the bus without actually controlling the bus.
Tank	A circuit comprising inductance and capacitance which can store electrical energy over a finite band of frequencies.
TCP/IP	Transmission Control Protocol/Internet Protocol. The collective term for the suite of layered protocols that ensures reliable data transmission in an internet (a network of packet switching networks functioning as a single large network). Originally developed by the US Department of Defense in an effort to create a network that could withstand an enemy attack.
TDM	Time Division Multiplexer. A device that accepts multiple channels on a single transmission line by connecting terminals, one at a time, at regular intervals, interleaving bits (bit TDM) or characters (Character TDM) from each terminal.
TDR	Time Domain Reflectometer. This testing device sends pulses down the cable and enables the user to determine cable quality (distance to defect and type of defect) by the reflections received back.
Temperature Rating	The maximum, and minimum temperature at which an insulating material may be used in continuous operation without loss of its basic properties.
Text Mode	Signals from the hardware to the display device are only interpreted as text characters.
Thresholding	The process of defining a specific intensity level for determining which of two values will be assigned to each pixel in binary processing. If the pixel's brightness is above the threshold level, it will appear in white in the image; if it is below the threshold level, it will appear black.
TIA	Telecommunications Industry Association.
Time Division	The process of transmitting multiple signals over a single channel by multiplexing taking samples of each signal in a repetitive time sequenced fashion.
Time Sharing	A method of computer operation that allows several interactive terminals to use one computer.
Time Domain	The display of electrical quantities versus time.
Token Ring	Collision free, deterministic bus access method as per IEEE 802.2 ring topology.
TOP	Technical Office Protocol. A user association in USA which is primarily concerned with open communications in offices.
Topology	Physical configuration of network nodes, e.g. bus, ring, star, tree.
Transceiver	A combination of transmitter and receiver.
Transducer	Any device that generates an electrical signal from real-world physical measurements. Examples are LVDTs, strain gauges, thermocouples and RTDs. A generic term for sensors and their supporting circuitry.
Transient	An abrupt change in voltage of short duration.
Transmission Line	One or more conductors used to convey electrical energy from one point to another.
Transport Layer	Layer 4 of the ISO/OSI Reference Model, concerned with providing a network independent reliable message interchange service to the application oriented layers (layers 5 through 7).
Trigger	A rising edge at an 8254 timer/counter's gate input.
Trunk	A single circuit between two points, both of which are switching centres or individual distribution points. A trunk usually handles many channels simultaneously.
Twisted Pair	A data transmission medium, consisting of two insulated copper wires twisted together. This improves its immunity to interference from nearby electrical sources that may corrupt the transmitted signal.

UART	Universal Asynchronous Receiver/Transmitter. An electronic circuit that translates the data format between a parallel representation, within a computer, and the serial method of transmitting data over a communications line.
UHF	Ultra High Frequency.
Unbalanced Circuit	A transmission line in which voltages on the two conductors are unequal with respect to ground e.g. a coaxial cable.
Unipolar Inputs	When set to accept a unipolar signal, the channel detects and converts only positive voltages. (Example: 0 to +10 V).
Unloaded Line	A line with no loaded coils that reduce line loss at audio frequencies.
Upconverter	A device used to translate a modulated signal to a higher band of frequencies.
Uplink	The path from an earth station to a satellite.
USRT	Universal Synchronous Receiver/Transmitter. See UART.
UTP	Unshielded Twisted Pair.
V.35	CCITT standard governing the transmission at 48 kbps over 60 to 108 kHz group band circuits.
VCO	Voltage controlled oscillator. Uses variable DC applied to tuning diodes to change their junction capacitances. This results in the output frequency being dependent on the input voltage.
Velocity of Propagation	The speed of an electrical signal down a length of cable compared to speed in free space expressed as a percentage.
VFD	Virtual Field Device. A software image of a field device describing the objects supplied by it eg measured data, events, status etc which can be accessed by another node on the network.
VGA	Video Graphics Array. This standard utilizes analog signals only (between 0 and 1 V) offering a resolution of 640 by 480 pixels, a palette of 256 colors out of 256000 colors and the ability to display 16 colors at the same time.
VHF	Very High Frequency.
Vidicon	A small television tube originally developed for closed-circuit television. It is about one inch (2.54 cm) in diameter and five inches (12.7 cm) long. Its controls are relatively simple and can be operated by unskilled personnel. The Vidicon is widely used in broadcast service.
Volatile Memory	A storage medium that loses all data when power is removed.
Voltage Rating	The highest voltage that may be continuously applied to a wire in conformance with standards of specifications.
VRAM	Volatile Random Access Memory. See RAM.
VSD	Variable Speed Drive.
VT	Virtual Terminal.
WAN	Wide Area Network.
Waveguide	A hollow conducting tube used to convey microwave energy.
Wedge Filter	An optical filter so constructed that the density increases progressively from one end to the other, or angularly around a circular disk.
Word	The standard number of bits that a processor or memory manipulates at one time. Typically, a word has 16 bits.
X.21	CCITT standard governing interface between DTE and DCE devices for synchronous operation on public data networks.
X.25 Pad	A device that permits communication between non X.25 devices and the devices in an X.25 network.
X.25	CCITT standard governing interface between DTE and DCE device for terminals operating in the packet mode on public data networks.

X.3/X.28/X.29	A set of internationally agreed standard protocols defined to allow a character oriented device, such as a visual display terminal, to be connected to a packet switched data network.
X-ON/X-OFF	Control characters used for flow control, instructing a terminal to start transmission (X-ON) and end transmission (X-OFF).

Please click the advert



MSM

MAASTRICHT SCHOOL OF MANAGEMENT

Increase your impact with MSM Executive Education



For almost 60 years Maastricht School of Management has been enhancing the management capacity of professionals and organizations around the world through state-of-the-art management education.

Our broad range of Open Enrollment Executive Programs offers you a unique interactive, stimulating and multicultural learning experience.

**Be prepared for tomorrow’s management challenges and apply today.**

For more information, visit [www.msm.nl](http://www.msm.nl) or contact us at +31 43 38 70 808 or via [admissions@msm.nl](mailto:admissions@msm.nl)

the globally networked management school

# Appendix B

## Units and Abbreviations

Unit Symbol	Unit	Quantity
m	metre	length
kg	kilogram	mass
s	second	time
A	ampere	electric current
K	kelvin	thermodynamic temp
cd	candela	luminous intensity

Table B.1  
SI units

Symbol	Prefix	Factor by which unit is multiplied
T	tera	$10^{12}$
G	giga	$10^9$
M	mega	$10^6$
k	kilo	$10^3$
h	hecto	$10^2$
da	deca	10
d	deci	$10^{-1}$
c	centi	$10^{-2}$
m	milli	$10^{-3}$
$\mu$	micro	$10^{-6}$
n	nano	$10^{-9}$
p	pico	$10^{-12}$

Table B.2  
Decimal Prefixes

Quantity	Unit	Symbol	Equivalent
plane angle	radian	rad	-
force	newton	N	$\text{kg m/s}^2$
work, energy heat	joule	J	N m
power	watt	W	J/s
frequency	hertz	Hz	$\text{s}^{-1}$
viscosity: kinematic	-	$\text{m}^2/\text{s}$	10 c St (Centistoke)
dynamic	-	$\text{Ns/m}^2$ or Pa s	$10^3$ cP (Centipoise)
pressure	-	Pa or $\text{N/m}^2$	pascal, Pa

Table B.3  
Supplementary and Derived Units

Quantity	Electrical unit	Symbol	Derived unit
potential	volt	V	W/A
resistance	ohm	$\Omega$	V/A
charge	coulomb	C	A s
capacitance	farad	F	A s/V
electric field strength	-	V/m	-
electric flux density	-	C/m <sup>2</sup>	-

**Table B.4** Supplementary and Derived Unit (electrical)

Quantity	Magnetic unit	Symbol	Derived unit
magnetic flux	weber	Wb	V s = Nm/A
inductance	henry	H	V s/A = Nm/A <sup>2</sup>
magnetic field strength	-	A/m	-
magnetic flux density	tesla	T	Wb/m <sup>2</sup> = (N)/(Am)

**Table B.5** Supplementary and Derived Units (magnetic)

Name	Symbol	Equivalent
Avogadro's number	N	$6.023 \times 10^{26}$ /(kg mol)
Bohr magneton	B	$9.27 \times 10^{-24}$ A m 25 <sup>2</sup>
Boltzmann's constant	k	$1.380 \times 10^{-23}$ J/k
Stefan-Boltzmann constant	d	$5.67 \times 10^{-8}$ W/(m <sup>2</sup> K <sup>4</sup> )
Characteristic impedance of free space	$Z_0$	$(\mu_0/\epsilon_0)^{1/2} = 120\pi\Omega$
Electron volt	eV	$1.602 \times 10^{-19}$ J
Electron charge	e	$1.602 \times 10^{-19}$ C
Electronic rest mass	$m_e$	$9.109 \times 10^{-31}$ kg
Electronic charge to mass ratio	$e/m_e$	$1.759 \times 10^{11}$ C/kg
Faraday constant	F	$9.65 \times 10^7$ C/(kg mol)
Permeability of free space	$\mu_0$	$4\pi \times 10^{-7}$ H/m
Permittivity of free space	$\epsilon_0$	$8.85 \times 10^{-12}$ F/m
Planck's constant	h	$6.626 \times 10^{-34}$ J s
Proton mass	$m_p$	$1.672 \times 10^{-27}$ kg
Proton to electron mass ratio	$m_p/m_e$	1835.6
Standard gravitational acceleration	g	9.80665 m/s <sup>2</sup> 9.80665 N/kg
Universal constant of gravitation	G	$6.67 \times 10^{-11}$ N m <sup>2</sup> /kg <sup>2</sup>
Universal gas constant	$R_0$	8.314 kJ/(kg mol K)
Velocity of light in vacuo	C	$2.9979 \times 10^8$ m/s
Volume of 1 kg mol of ideal gas at 1 atm & 0°C	-	22.41 m <sup>3</sup>
Temperature	°C	5/9(°F - 32)
Temperature	K	5/9(°F + 459.67) 5/9°R °C + 273.15

**Table B.6** Physical Constants

# Appendix C

## Commonly used Formulae

### Symbols used in formulae

The symbols described in the following table are used in the formulae shown in the next section

Symbol	Description	SI Unit
a	Velocity of sound	$\text{ms}^{-1}$
a	Acceleration	$\text{ms}^{-2}$
A	Area	$\text{m}^2$
c	Velocity of light	$\text{ms}^{-1}$
C	Capacitance	F
D	Diameter	m
E	Young's modulus	$\text{Nm}^{-2}$
$\Delta E$	Energy difference	J
f	Frequency	Hz
F	Force	N
H	Magnetising force magnetic field strength	$\text{Am}^{-1}$
I	Current	A

Please click the advert

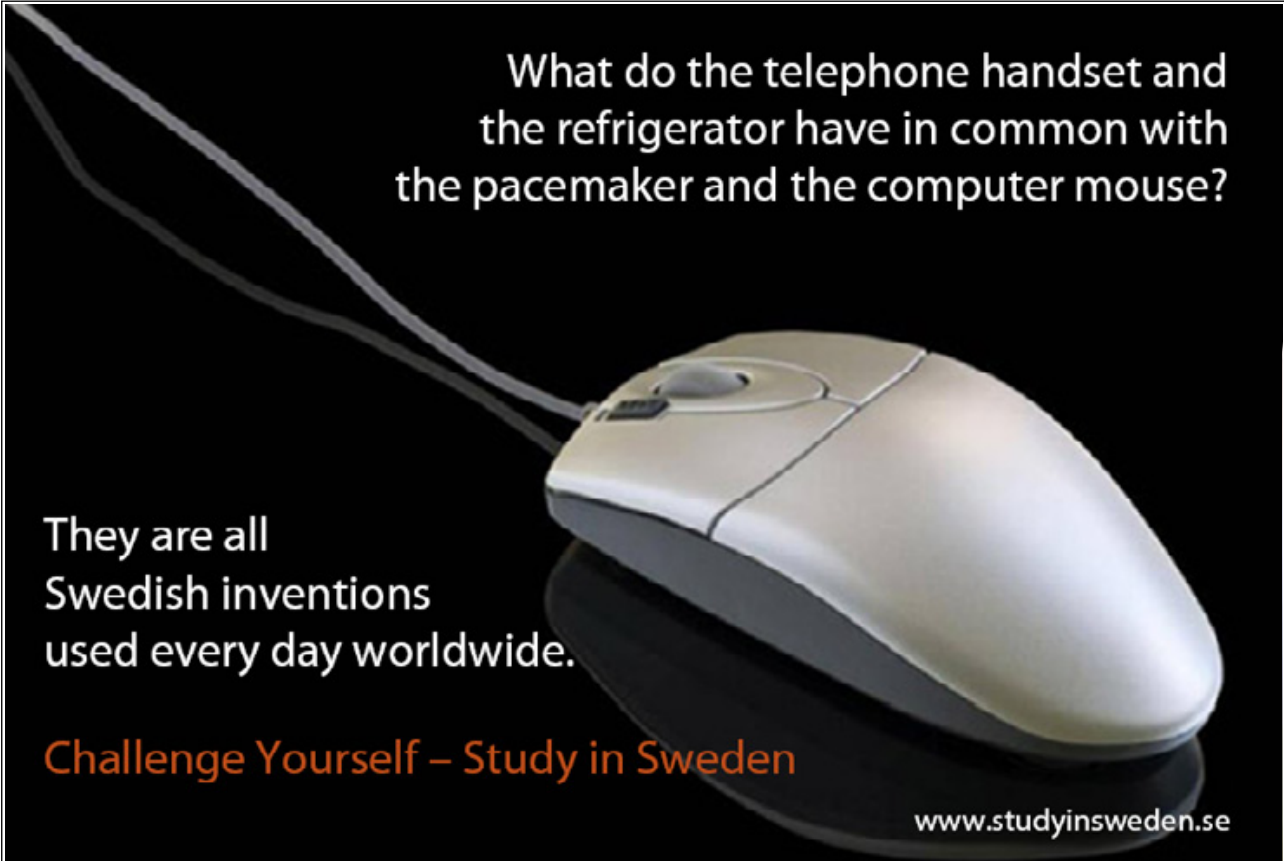

What do the telephone handset and the refrigerator have in common with the pacemaker and the computer mouse?

They are all Swedish inventions used every day worldwide.

Challenge Yourself – Study in Sweden

[www.studyinsweden.se](http://www.studyinsweden.se)

$I$	Moment of inertia	$\text{kgm}^2$
$k$	Radius of gyration	$\text{m}$
$k_p$	Pitch factor of winding	-
$l$	Length	$\text{m}$
$l$	Length of conductor	$\text{m}$
$L$	Inductance	$\text{H}$
$m$	Mass	$\text{kg}$
$M$	Momentum	$\text{kg.m.s}^{-1}$
$n$	Speed of rotation	$\text{rpm}$
$N$	Number of turns	-
$p$	Number of pole pairs	-
$Q$	Volumetric flow rate	$\text{m}^3\text{s}^{-1}$
$Q$	Charge	$\text{C}$
$R$	Resistance	$\Omega$
$s$	Fractional slip	-
$t$	Time	$\text{s}$
$T$	Time Factor	-
$T$	Torque	$\text{Nm}$
$T$	Temperature (absolute)	$\text{K}$
$\Delta T$	Temperature difference	$^{\circ}\text{C}$
$u$	Velocity	$\text{ms}^{-1}$
$v$	Velocity	$\text{ms}^{-1}$
$V$	Voltage	$\text{V}$
$V$	Volume	$\text{m}^3$
$x$	Distance (variables as in $dx$ )	$\text{m}$
$Z$	Number of armature conductors	-
$Z$	Impedance	$\Omega$
$a$	Coefficient of volumetric expansion	$\text{Hm}/(\text{mK})$
$a$	Resistance coefficient	$\Omega \text{K}^{-1}$
$b$	Coefficient of volumetric expansion	$\text{K}^{-1}$
$\epsilon_0$	Permittivity of free space	$\text{Fm}^{-1}$
$\epsilon_0$	Permittivity-relative	-
$\mu_0$	Permeability of free space	$\text{Hm}^{-1}$
$\mu_r$	Permeability-relative	-
$r_0$	Resistivity	$\Omega \text{m}^3$
$r$	Density	$\text{kgm}^3$
$s$	Stefan-Boltzmann constant	$\text{Wm}^{-2}\text{K}^{-4}$
$\varphi$	Angle	radians
$F$	Magnetic flux, flux per pole	$\text{Wb}$
$w$	Angular Velocity	$\text{rad.s}^{-1}$
$w_n$	Natural frequency	$\text{rad.s}^{-1}$
$w_0$	Natural frequency	$\text{rad.s}^{-1}$
$w_d$	Damped natural frequency	$\text{rad.s}$



## Formulae

Ohm's Law (DC version)

$$V = IR$$

$$I = \frac{V}{R}$$

Ohm's Law (AC version)

$$\underline{V} = \underline{I} \cdot \underline{Z}$$

Kirchhoff's Law

$$\sum_{j=0}^N I_j = 0$$

Power

$$P_{dc} = VI = I^2 R = \frac{V^2}{R}$$

$$P_{ac} = \text{Re}(\underline{V} \cdot \underline{I}) = VI \cos \phi$$

Resistance

Resistors in series:

$$R = R_1 + R_2 + R_3 + \dots$$

Resistors in parallel:

$$R = \frac{1}{\frac{1}{R_1} + \frac{1}{R_2} + \frac{1}{R_3} \dots}$$

Inductance

$$V = -L \frac{dI}{dt}$$

$$I = -\int \frac{V}{L} dt$$

$$L = N^2 \mu_o \mu_r \frac{a}{l}$$

for LR circuit decay, stored energy is calculated as follows:

$$Energy = \frac{1}{2} L I^2$$

Capacitance

$$Q = CV = \int idt$$

$$i = \frac{dQ}{dt} = C \frac{dV}{dt}$$

For n parallel plates:

$$C = \epsilon_o \epsilon_r (n-1) \frac{a}{d}$$

$$\epsilon_o = 8.85 \times 10^{-12} Fm^{-1}$$

Please click the advert

DESTINATIONS		GATE	ARRIVAL
INDUSTRY	IMPACT	OW	FASTER
GLOBAL	ASSIGNMENTS	OW	FASTER
SENIOR	CLIENT CONTACT	OW	FASTER
CAREER	DEVELOPMENT	OW	FASTER
MAKE	PARTNER	OW	FASTER

 **OLIVER WYMAN**



Oliver Wyman is a leading global management consulting firm that combines deep industry knowledge with specialized expertise in strategy, operations, risk management, organizational transformation, and leadership development. With offices in 50+ cities across 25 countries, Oliver Wyman works with the CEOs and executive teams of Global 1000 companies.  
An equal opportunity employer.

**GET THERE FASTER**

Some people know precisely where they want to go. Others seek the adventure of discovering uncharted territory. Whatever you want your professional journey to be, you'll find what you're looking for at Oliver Wyman.

Discover the world of Oliver Wyman at [oliverwyman.com/careers](http://oliverwyman.com/careers)



For RC circuit discharge:

$$i = -Ie^{-\frac{t}{RC}}$$

Stored energy:

$$W = \frac{1}{2} \epsilon_0 \epsilon_r a \left( \frac{V}{x} \right)^2$$

For capacitors in series:

$$C_{total} = \frac{1}{\frac{1}{C_1} + \frac{1}{C_2} + \frac{1}{C_3} \dots}$$

For capacitors in parallel:

$$C_{total} = C_1 + C_2 + C_3 + \dots$$

Electrostatics

$$F = \frac{Q_1 Q_2}{4\pi\epsilon_0 r^2}$$

$$\underline{F} = e \cdot \underline{E} = -e\Delta V$$

$$\underline{D} = \epsilon_0 \epsilon_r \underline{E}$$

Electromagnetism

$$E = -N \frac{d\phi}{dt}$$

$$B = \mu_0 \frac{1}{2\pi r}$$

$$F = BI$$

$$F = \mu_0 I_1 I_2 \frac{1}{2\pi d}$$

$$\frac{dH}{dl} = \frac{I \sin \alpha}{4\pi x^2}$$

For a solenoid:

$$H = \frac{NI}{l}$$

Magnetism

$$H = \frac{B}{\mu_o \mu_r}$$

For a magnetic circuit:

$$B = \frac{\Phi}{a}$$

Stored energy density:

$$Energy = \frac{1}{2} HB = \frac{1}{2} \frac{B^2}{\mu_o}$$

AC Circuits

$$V_{\max} = \frac{1}{\sqrt{2}} V_{\text{peak}}$$

$$\text{abs}(Z) = \left\{ R^2 + \left( \omega L - \frac{1}{\omega C} \right)^2 \right\}^{1/2}$$

$$Z = R + j\omega L + \frac{1}{j\omega C}$$

$$\text{Cos } \phi = \frac{R}{Z}$$

At resonance the following relationship holds true:

$$\omega = \omega_o = \frac{1}{\sqrt{LC}}$$

The Q factor can be calculated as follows:

$$Q_{\text{factor}} = \omega_o \frac{L}{R}$$

Sound

Note that decibels are not units as such but a ratio of voltages, currents and power, for example:

$$dB = 10 \log_{10} \frac{P_1}{P_2}$$

where: P1, P2 are the power levels:

$$dB = 20 \log_{10} \frac{V_1}{V_2}$$

For differing input and output impedances the following formula is appropriate:

$$dB = 20 \text{Log}_{10} \frac{V_1}{V_2} + 10 \text{Log}_{10} \frac{Z_2}{Z_1}$$

Where  $V_1, V_2$  are the voltages

$Z_1, Z_2$  are the impedances.

Please click the advert

**Day one**  
and you're ready

Day one. It's the moment you've been waiting for. When you prove your worth, meet new challenges, and go looking for the next one. It's when your dreams take shape. And your expectations can be exceeded. From the day you join us, we're committed to helping you achieve your potential. So, whether your career lies in assurance, tax, transaction, advisory or core business services, shouldn't your day one be at Ernst & Young?

**What's next for your future?**  
[ey.com/careers](http://ey.com/careers)

**ERNST & YOUNG**  
Quality In Everything We Do

© 2010 EYGM Limited. All Rights Reserved.

# Appendix D

## Resistor Color Coding

Resistor values are calculated according to the following color coding:

Color on resistor	Value allocation
Black	0
Brown	1
Red	2
Orange	3
Yellow	4
Green	5
Blue	6
Violet/Purple	7
Grey	8
White	9

Table D.1

Please click the advert



Hellmann's is one of Unilever's oldest brands having been popular for over 100 years. If you too share a passion for discovery and innovation we will give you the tools and opportunities to provide you with a challenging career. Are you a great scientist who would like to be at the forefront of scientific innovations and developments? Then you will enjoy a career within Unilever Research & Development. For challenging job opportunities, please visit [www.unilever.com/rdjobs](http://www.unilever.com/rdjobs).

Could it be   
Unilever



## Common Band Colors

Resistors have the following two major groupings of color coding:

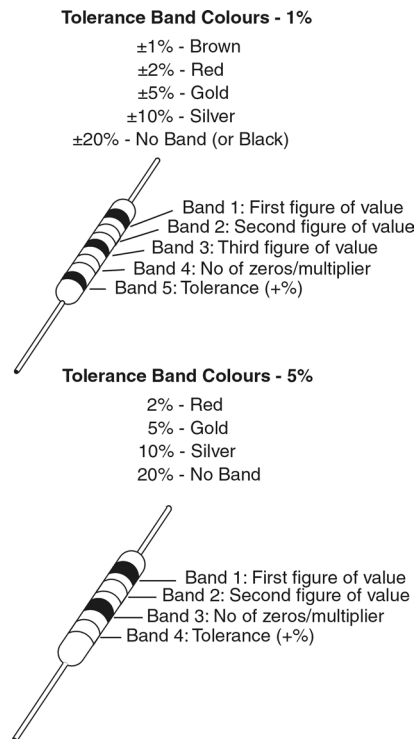

**Figure D.1** Color coding for tolerance resistors



# Who is IDC Technologies

IDC Technologies is a specialist in the field of industrial communications, telecommunications, automation and control and has been providing high quality training on an international basis for more than 16 years.

IDC Technologies consists of an enthusiastic team of professional engineers and support staff who are committed to providing the highest quality in their consulting and training services.

## The Benefits to You of Technical Training

The technological world today presents tremendous challenges to engineers, scientists and technicians in keeping up to date and taking advantage of the latest developments in the key technology areas.

The immediate benefits of attending an IDC Technologies workshop are:

- Gain practical hands-on experience
- Enhance your expertise and credibility
- Save \$\$\$ for your company
- Obtain state of the art knowledge for your company
- Learn new approaches to troubleshooting
- Improve your future career prospects

Please click the advert



360°  
thinking.

**Deloitte.**

Discover the truth at [www.deloitte.ca/careers](http://www.deloitte.ca/careers)

© Deloitte & Touche LLP and affiliated entities.

## The IDC Technologies Approach to Training

All workshops have been carefully structured to ensure that attendees gain maximum benefits. A combination of carefully designed training software, hardware and well written documentation, together with multimedia techniques ensure that the workshops are presented in an interesting, stimulating and logical fashion.

IDC Technologies has structured a number of workshops to cover the major areas of technology. These workshops are presented by instructors who are experts in their fields, and have been attended by thousands of engineers, technicians and scientists world-wide, who have given excellent reviews.

The IDC Technologies team of professional engineers is constantly reviewing the workshops and talking to industry leaders in these fields, thus keeping the workshops topical and up to date.

## Technical Training Workshops

IDC is continually developing high quality state of the art workshops aimed at assisting engineers, technicians and scientists. Current workshops include:

### DATA COMMUNICATIONS & NETWORKING

- Best Practice in Industrial Data Communications
- Practical Data Communications & Networking for Engineers and Technicians
- Practical DNP3, 60870.5 & Modern SCADA Communication Systems
- Practical Troubleshooting & Problem Solving of Ethernet Networks
- Practical FieldBus and Device Networks for Engineers and Technicians
- Practical Fieldbus, DeviceNet and Ethernet for Industry
- Practical Use and Understanding of Foundation FieldBus for Engineers and Technicians
- Practical Fibre Optics for Engineers and Technicians
- Practical Industrial Communication Protocols
- Practical Troubleshooting & Problem Solving of Industrial Data Communications
- Practical Troubleshooting, Design & Selection of Industrial Fibre Optic Systems for Industry
- Practical Industrial Networking for Engineers & Technicians
- Practical Industrial Ethernet & TCP/IP Networks
- Practical Local Area Networks for Engineers and Technicians
- Practical Routers & Switches (including TCP/IP and Ethernet) for Engineers & Technicians
- Practical TCP/IP and Ethernet Networking for Industry
- Practical Fundamentals of Telecommunications and Wireless Communications
- Practical Radio & Telemetry Systems for Industry
- Practical TCP/IP Troubleshooting & Problem Solving for Industry
- Practical Troubleshooting of TCP/IP Networks
- Practical Fundamentals of Voice over IP (VOIP) for Engineers and Technicians
- Wireless Networking and Radio Telemetry Systems for Industry
- Wireless Networking Technologies for Industry

## ELECTRICAL

- Practical Maintenance & Troubleshooting of Battery Power Supplies
- Practical Electrical Network Automation & Communication Systems
- Safe Operation & Maintenance of Circuit Breakers and Switchgear
- Troubleshooting, Maintenance & Protection of AC Electrical Motors and Drives
- Practical Troubleshooting of Electrical Equipment and Control Circuits
- Practical Earthing, Bonding, Lightning & Surge Protection
- Practical Distribution & Substation Automation for Electrical Power Systems
- Practical Solutions to Harmonics in Power Distribution
- Practical High Voltage Safety Operating Procedures for Engineers and Technicians
- Practical Electrical Wiring Standards - National Rules for Electrical Installations -
- Lightning, Surge Protection and Earthing of Electrical & Electronic Systems
- Practical Power Distribution
- Practical Power Quality: Problems & Solutions

## ELECTRONICS

- Practical Digital Signal Processing Systems for Engineers and Technicians
- Practical Embedded Controllers: Troubleshooting and Design
- Practical EMC and EMI Control for Engineers and Technicians
- Practical Industrial Electronics for Engineers and Technicians
- Practical Image Processing and Applications
- Power Electronics and Variable Speed Drives: Troubleshooting & Maintenance
- Practical Shielding, EMC/EMI, Noise Reduction, Earthing and Circuit Board Layout

## INFORMATION TECHNOLOGY

- Practical Web-Site Development & E-Commerce Systems for Industry
- Industrial Network Security for SCADA, Automation, Process Control & PLC Systems
- SNMP Network Management: The Essentials
- VisualBasic Programming for Industrial Automation, Process Control & SCADA Systems

## INSTRUMENTATION, AUTOMATION & PROCESS CONTROL

- Practical Analytical Instrumentation in On-Line Applications
- Practical Alarm Systems Management for Engineers and Technicians
- Practical Programmable Logic Controller's (PLCs) for Automation and Process Control
- Practical Batch Management & Control (Including S88) for Industry
- Practical Boiler Control and Instrumentation for Engineers and Technicians
- Practical Programming for Industrial Control - using ( IEC 1131-3 and OPC )
- Practical Distributed Control Systems (DCS) for Engineers & Technicians
- Practical Data Acquisition using Personal Computers and Standalone Systems

- Best Practice in Process, Electrical & Instrumentation Drawings and Documentation
- Practical Troubleshooting of Data Acquisition & SCADA Systems
- Practical Industrial Flow Measurement for Engineers and Technicians
- Practical Hazops, Trips and Alarms
- Practical Hazardous Areas for Engineers and Technicians
- A Practical Mini MBA in Instrumentation and Automation
- Practical Instrumentation for Automation and Process Control
- Practical Intrinsic Safety for Engineers and Technicians
- Practical Tuning of Industrial Control Loops
- Practical Motion Control for Engineers and Technicians
- Practical SCADA and Automation for Managers, Sales and Administration
- Practical Automation, SCADA and Communication Systems: A Primer for Managers
- Practical Fundamentals of OPC (OLE for Process Control)
- Practical Process Control for Engineers and Technicians
- Practical Process Control & Tuning of Industrial Control Loops
- Practical Industrial Programming using 61131-3 for PLCs
- Practical SCADA & Telemetry Systems for Industry
- Practical Shutdown & Turnaround Management for Engineers and Managers
- Practical Safety Instrumentation and Shut-down Systems for Industry
- Practical Fundamentals of E-Manufacturing, MES and Supply Chain Management
- Practical Safety Instrumentation & Emergency Shutdown Systems for Process Industries
- Control Valve Sizing, Selection and Maintenance

# Grant Thornton—<sup>REALLY</sup> a great place to work.

We're proud to have been recognized as one of Canada's Best Workplaces by the Great Place to Work Institute™ for the last four years. In 2011 Grant Thornton LLP was ranked as the fifth Best Workplace in Canada, for companies with more than 1,000 employees. We are also very proud to be recognized as one of Canada's top 25 Best Workplaces for Women and as one of Canada's Top Campus Employers.



**Priyanka Sawant**  
Manager

Please click the advert



Audit • Tax • Advisory  
[www.GrantThornton.ca/Careers](http://www.GrantThornton.ca/Careers)



© Grant Thornton LLP. A Canadian Member of Grant Thornton International Ltd

Download free ebooks at [bookboon.com](http://bookboon.com)

## MECHANICAL ENGINEERING

- Practical Fundamentals of Heating, Ventilation & Airconditioning (HVAC)
- Practical Boiler Plant Operation and Management for Engineers and Technicians
- Practical Bulk Materials Handling (Conveyors, Bins, Hoppers & Feeders)
- Practical Pumps and Compressors: Control, Operation, Maintenance & Troubleshooting
- Practical Cleanroom Technology and Facilities for Engineers and Technicians
- Gas Turbines: Troubleshooting, Maintenance & Inspection
- Practical Hydraulic Systems: Operation and Troubleshooting
- Practical Lubrication Engineering for Engineers and Technicians
- Practical Safe Lifting Practice and Maintenance
- Practical Mechanical Drives (Belts, Chains etc) for Engineers & Technicians
- Fundamentals of Mechanical Engineering
- Practical Pneumatics: Operations and Troubleshooting for Engineers & Technicians
- Practical Centrifugal Pumps - Optimising Performance
- Practical Machinery and Automation Safety for Industry
- Practical Machinery Vibration Analysis and Predictive Maintenance

## PROJECT & FINANCIAL MANAGEMENT

- Practical Financial Fundamentals and Project Investment Decision Making
- How to Manage Consultants
- Marketing for Engineers and Technical Personnel
- Practical Project Management for Engineers and Technicians
- Practical Specification and Technical Writing for Engineers

## CHEMICAL ENGINEERING

- Practical Fundamentals of Chemical Engineering

## CIVIL ENGINEERING

- Hazardous Waste Management and Pollution Prevention
- Structural Design for non-structural Engineers
- Best Practice in Sewage and Effluent Treatment Technologies

## Comprehensive Training Materials

### Workshop Documentation

All IDC Technologies workshops are fully documented with complete reference materials including comprehensive manuals and practical reference guides.

## Software

Relevant software is supplied with most workshops. The software consists of demonstration programs which illustrate the basic theory as well as the more difficult concepts of the workshop.

## Hands-On Approach to Training

IDC Technologies engineers have developed the workshops based on the practical consulting expertise that has been built up over the years in various specialist areas. The objective of training today is to gain knowledge and experience in the latest developments in technology through cost effective methods.

The investment in training made by companies and individuals is growing each year as the need to keep topical and up to date in the industry which they are operating is recognized. As a result, IDC Technologies instructors place particular emphasis on the practical, hands-on aspect of the workshops presented.

## On-site Workshops

In addition to the external workshops which IDC Technologies presents on a world-wide basis, all IDC Technologies workshops are also available for on-site (in-house) presentation at our clients premises.

On-site training is a cost effective method of training for companies with many delegates to train in a particular area. Organizations can save valuable training \$\$\$ by holding workshops on-site, where costs are significantly less. Other benefits are IDC Technologies ability to focus on particular systems and equipment so that attendees obtain only the greatest benefits from the training.

All on-site workshops are tailored to meet with clients training requirements and workshops can be presented at beginners, intermediate or advanced levels based on the knowledge and experience of delegates in attendance. Specific areas of interest to the client can also be covered in more detail.

Our external workshops are planned well in advance and you should contact us as early as possible if you require on-site/ customized training. While we will always endeavor to meet your timetable preferences, two to three months notice is preferable in order to successfully fulfil your requirements.

Please don't hesitate to contact us if you would like to discuss your training needs.

## Customized Training

In addition to standard on-site training, IDC Technologies specializes in customized workshops to meet client training specifications. IDC Technologies has the necessary engineering and training expertise and resources to work closely with clients in preparing and presenting specialized workshops.

These workshops may comprise a combination of all IDC Technologies workshops along with additional topics and subjects that are required. The benefits to companies in using training is reflected in the increased efficiency of their operations and equipment.



### Training Contracts

IDC Technologies also specializes in establishing training contracts with companies who require ongoing training for their employees. These contracts can be established over a given period of time and special fees are negotiated with clients based on their requirements. Where possible IDC Technologies will also adapt workshops to satisfy your training budget.

*References from various international companies to whom IDC Technologies is contracted to provide on-going technical training are available on request.*

Some of the thousands of Companies world-wide that have supported and benefited from IDC Technologies workshops are:

#### Australia

Alcoa • Alinta Gas • Ampol Refineries • Ansto • Australian Communications Authority • Australian Geological Society • BHP Billiton • BOC Gases • Boeing Constructors Inc • Brisbane City Council • British Aerospace Australia • Ci Technologies • Civil Aviation Authority • Comalco Aluminium • CSIRO • Delta Electricity • Dept of Defence • Dept of Transport and Works • DSTO • Duke Energy International • Emerson Process Management • Energex • ERG Group • Ergon Energy • ETSA • Gippsland Water • Gladstone Tafe College • Gosford City Council • Great Southern Energy • Hamersley Iron • Hewlett Packard • Holden Ltd • Honeywell • I&E Systems Pty Ltd • Integral Energy • Metro Brick • Millenium Chemicals • Mt Isa Mines • Murdoch University • Nabalco • NEC • Nilson Electric • Normandy Gold • Nu-Lec Industries • Parker Hannafin • Pharmacia & Upjohn • Power & Water Authority NT • Powercor • Powerlink • Prospect Electricity • Queensland Alumina • Raaf • Raytheon • RGC Mineral Sands • Robe River Iron Associates • Royal Darwin

Please click the advert

**The Wake**  
the only emission we want to leave behind

Low-speed Engines Medium-speed Engines Turbochargers Propellers Propulsion Packages PrimeServ

The design of eco-friendly marine power and propulsion solutions is crucial for MAN Diesel & Turbo. Power competencies are offered with the world's largest engine programme – having outputs spanning from 450 to 87,220 kW per engine. Get up front! Find out more at [www.mandieselturbo.com](http://www.mandieselturbo.com)

Engineering the Future – since 1758.  
**MAN Diesel & Turbo**



Hospital • Santos Ltd • Schneider Electric • Shell • Snowy Mountain Hydro • SPC Fruit • Stanwell Power Station • Telstra • Tiwest • Uncle Bens • Vision • Wesfarmers CSBP • Western Power • Westrail • WMC • Woodside • Worsley Alumina • Wyong Shire • Yokogawa Australia

## Botswana

De Beers - Jwaneng Mine • De Beers - Orapa Mine

## Canada

Aircom Industries (76) Ltd • Atco Electric • BC Gas • BC Hydro • City of Ottawa • City of Saskatoon • Conoco • Dept of National Defence • Enbridge Pipelines • Enmax • Ford Electronics • GE Energy Services • General Motors • Guillevin Automation • Husky Oil • Imperial Oil • INCO Ltd • Labrador Hydro • Manitoba Hydro • Manitoba Lotteries Corp • Memorial University of New Foundland • New Brunswick Power • Nova Chemicals • Nxtphase Corporation • Ontario Hydro • Ottawa Hydro • Petro Canada • Power Measurement Ltd • Saskatchewan Power • Spartan Controls • Stora • Suncor Energy • Syncrude • Telus • Trans Canada Pipelines • Trojan Technologies • Wascana Energy • Weyerhaeuser

## Ireland

Bayer Diagnostics • ESB Distribution • Intel • Irish Cement • Janssen Pharmaceuticals • Microsol Limited • Pfizer • Pilz Ireland • Proscon Engineering

## Nambia

Namibian Broadcasting Corporation • Nampower • Namwater

## New Zealand

ACI Packaging • Anchor Products • Auckland Regional Council • Ballance Agri Nutrients • Contact Energy • Ericsson • Fisher & Paykel • GEC Alsthom • James Hardie • Methanex • Natural Gas • NZ Water and Waste Assoc • Norske Skog • NZ Aluminium Smelters • NZ Refining Co • Pan Pac Forest Products • Powerco • Rockwell • Rotorua District Council • Royal New Zealand Navy • The University of Auckland

## Singapore

Activemedia Innovation Pte Ltd • Flotech Controls • Land Transport Authority • Ngee Ann Polytechnic • Power Seraya Ltd • Westinghouse • Yokogawa Singapore

## South Africa

Anglo American • Bateman Metals • Caltex Refineries • Chevron • Columbus Stainless • De Beers • Durban Metro • Eastern Cape Tech • Eskom • Grintek Ewation • Highveld Steel • Illovo Sugar • Impala Platinums • Iscor • IST • Joy Mining • Lever Ponds • Metso Automation • Middleburg Ferrochrome • Mintek • Mondi Kraft • Mossgas • Namaqua Sands • Nestle • Orbicom • Rand Water Board • Richards Bay Minerals • SA Navy • SABC • Saldanha Steel • Sappi • Sasol • Spoornet • Umgeni Water • Western Platinum • Witwatersrand Technikon • Yelland Controls

## United Kingdom

24 Seven • ABB Automation Ltd • Aer Rianta • Air Products • Allied Colloids • Allied Distillers • Alstom • BAE Systems • Bechtel • BNFL - Magnox Generation • BP Chemicals • British American Tobacco • British Energy • British Gas • British Steel • Cegelec • Conoco • Corus Group Plc • Energy Logistics • Eurotherm • Eurotunnel • Evesham Micros • Exult Ltd • Fisher Rosemount • GEC Meters • Glaxo Smith Kline • Glaxo Wellcome • Great Yarmouth Power • Halliburton • Honeywell • ICI Nobel Enterprises • ICS Triplex • Inmarsat Ltd • Instem Limited • Johnson Matthey • Kodak • Kvaerner Energy • Lever Fabrige • Lindsay Oil Refinery • Lloyds • Logica • Lucas Aerospace • Mobil Oil • NEC • Nissan • Northern Lighthouse Board • OKI Europe Ltd • Phillips Petroleum • Powergen • Qinetiq • Rail Track Systems • Rig Tech • Roberts & Partners • Rolls Royce • Rover Group • Rugby Cement • Scottish Courage • Scottish Hydro Electric Plc • Scottish Power • Shell Chemicals • Shotton Paper Plc • Siemens • Strathclyde Water • Thames Water • Toyota • Transco • Trend Control Systems Ltd • UKAEA • United Kingdom Paper • Yarrow Shipbuilders • Yorkshire Electric

## USA

Alcatel • Allen Bradley • Astra Zeneca Pharmaceuticals • Avista Corporation • Boeing • Chevron • City of Detroit • Daishowa Paper Mill • Degussa Corporation • Dept of Energy • Detroit Water • Exxon Mobil Chemical Company • FMC Corporation • General Monitors • Honeywell • Hughes Aircraft • ISA • K-Tron Institute • Mckee Foods • Milltronics • NASA • Pepperl Fuchs • Phelps Dodge • Philip Morris • San Diego County Water Authority • San Francisco Water Department • Santa Clara Valley Water • Securities Industry Automation Corp • Siemens Power • Siemens Westinghouse • Toyota • Tucson Electric • United Technologies Corp (UTC) • Valtek • Washington Water Power • Wisconsin Power • Zeneca

## IDC Technologies - Worldwide Offices

For further information about current or future workshops please contact your local office:

### Australia

PO Box 1093, West Perth WA 6872

Tel: (08) 9321 1702      Fax: (08) 9321 2891

### Canada

402-814 Richards Street, Vancouver BC V6B 3A7

Tel: 1800 324 4244      Fax: 1800 434 4045

### Ireland

Caoran, Baile na hAbhann Co Galway

Tel: (01) 473 3190

Fax: (01) 473 3191

### Malaysia

26 Jalan Kota Raja E27/E, Hicom Town Center,

Seksyen 27, 40400 Shah Alam, Selangor

Tel: (03) 5192 3800 Fax: (03) 5192 3801

#### New Zealand

PO Box 76142, Manukau City 2241 Auckland

Tel: (09) 263 4759 Fax: (09) 262 2304

#### Singapore

100 Eu Tong Sen Street, #04-11 Pearl's Centre, 059812

Tel: (65) 6224 6298 Fax: (65) 6224 7922

#### South Africa

68 Pretorius Street, President Park, Midrand

PO Box 389, Halfway House 1685

Tel: 011 024 5520/1/2/3/4/5

Fax: (086) 692 4368

#### UK

Suite 18, Fitzroy House, Lynwood Drive,

Worcester Park, Surrey KT4 7AT

Tel: (020) 8335 4014 Fax: (020) 8335 4120

USA

10685-B Hazelhurst Drive #6175, Houston TX 77043

Toll Free Tel: 1800 324 4244 Toll Free Fax: 1800 434 4045

Email: [idc@idc-online.com](mailto:idc@idc-online.com)

Web site: [www.idc-online.com](http://www.idc-online.com)

Please click the advert

**I WANT TO CHANGE DIRECTION,  
AND THE WORLD.**

**GOT-THE-ENERGY-TO-LEAD.COM**

We believe that energy suppliers should be renewable, too. We are therefore looking for enthusiastic new colleagues with plenty of ideas who want to join RWE in changing the world. Visit us online to find out what we are offering and how we are working together to ensure the energy of the future.

**RWE**  
The energy to lead

Download free ebooks at [bookboon.com](http://bookboon.com)

# Notes