

Campus Design and Planning
(Currently under development)

SECTION 2: HEALTH AND SAFETY CONTENTS

2.1	INTRODUCTION	3
2.2	INTEGRATING DESIGN AND RISK MANAGEMENT – SAFETY IN DESIGN	3
2.2.1	Buildings and Structures Requiring Reviews	3
2.2.2	Design Stages for Review	3
2.2.3	Review Process	5
2.3	GENERAL	6
2.3.1	Space and General Physical Layout	6
2.3.2	Wall Fitments and Shelving	7
2.3.3	Chemicals	7
2.3.4	Dangerous Goods Stores	8
2.3.5	Portable Fire Extinguishers and Fire Blankets	9
2.3.6	Safety Showers	9
2.3.7	Emergency Eye-Wash Stations	9
2.3.8	Safety Signs	9
2.3.9	Asbestos and Hazardous Materials	10
2.3.10	Heights	10
2.3.11	Plant	10
2.4	IONISING RADIATION	11
2.4.1	Ionising Radiation Control	11
2.5	LABORATORIES	11
2.5.1	General	11
2.5.2	Wet Laboratories	13
2.5.3	Dry Laboratories	14
2.5.4	Biological safety cabinets, cytotoxic drug safety cabinets and fume hoods	15
2.5.5	Microscope workstations	15
2.6	HUMAN FACTORS AND ERGONOMICS	15
2.6.1	Background	15
2.6.2	Space and General Physical Layout	16
2.6.3	Light and Lighting	17
2.6.4	Noise	18
2.6.5	Thermal Comfort and Air Quality	19
2.6.6	Flooring and Pedestrian Surfaces	19
2.6.7	Storage Systems – Shelving, Racking and Compactus	20
2.6.8	Storage Systems – Mobile and Standalone	21

2.6.9	Doors and Handles	21
2.6.10	Desks – General Requirements	22
2.6.11	Desks – Sit/Stand	23
2.6.12	Desks – Fixed Height Seated	23
2.6.13	Fixed Height Standing	24
2.6.14	Computers (PC), Laptops and Monitor Arms	24
2.6.15	Tables	24
2.7	SEATING SPECIFICATIONS	24
2.7.1	Chairs – General Requirements	24
2.7.2	Staff Computer Workstation Chairs	25
2.7.3	Student Task Chairs	25
2.7.4	Meeting Room, Interview/Consulting Room Chairs	26
2.7.5	Staff High Office Workstation/Counter Stools	26
2.7.6	Student High Office Workstation/Counter Stools	26
2.7.7	Wet Laboratory Chairs	27
2.7.8	Examination Room/Seminar Room and Events Chairs	27
2.7.9	Occasional Seating/Chairs	27
2.7.10	Lecture Theatre Seating	28
2.8	DESIGN AND LAYOUT OF COMMON AREAS	28
2.8.1	Office Design and Layout	29
2.8.2	Meeting Rooms	29
2.8.3	Reception Desks/Service Counters	30
2.8.4	Teaching and Collaborative Learning Spaces, Lecture Theatres	31
2.9	DESIGN CHANGE AUTHORISATION	31

2.1 INTRODUCTION

The University is committed to providing a safe and healthy working and learning environment. These Design Standards support that commitment by ensuring that health and safety requirements are included in the design of buildings, structures and landscape works.

This section details the health and safety requirements during the design phase of new works and refurbishment projects.

Project architects and consultants, in designing the building and the contractor during the construction process, shall adhere to:

- all relevant Acts, Regulations, Compliance Codes and Standards (listed throughout this Design Standard); and
- other relevant sections of the University's Design Standards and documents.

Consultants must be aware of their obligations to carry out risk assessments during the design phase for work areas as per Occupational Health and Safety Act 2004.

2.2 INTEGRATING DESIGN AND RISK MANAGEMENT – SAFETY IN DESIGN

2.2.1 *Buildings and Structures Requiring Reviews*

Safety in design (SiD) reviews shall be completed for works associated with the following:

- buildings/structures to be used as workplaces (ongoing or occasional);
- parts of the building/structure including fixtures integral to its use as a workplace;
- temporary structures; and
- roads, footpaths and landscape areas.

For any design where it can be reasonably expected that people may need to work within, on, or around the building or structure, either as an end-user and/or maintainer of the building or structure, then a SiD review shall be completed.

2.2.2 *Design Stages for Review*

SiD reviews (Figure 1) shall be carried out in line with the [Model Code of Practice: Safe design of structures](#) (Safe Work Australia). They shall be completed as early in the design process as practicable, during design phase and throughout the life of the project. This can be outlined as follows:

- pre-design phase (siting, feasibility study);
- conceptual and schematic design phase;
- design development phase;
- construction documentation; and
- construction, refurbishment or modification.

It is recommended that at each SiD review a representative from each of the following project stakeholder groups is in attendance, or is given the opportunity to contribute prior to the review.

Representatives include but are not limited to:

- designers (e.g. building, industrial, landscape, interior);
- architects;
- health and safety consultants and experts;
- people who will be utilising the building/structure as a workplace;
- people who will be constructing the building/structure;
- people who will be maintaining/managing the building/structure and associated facilities.

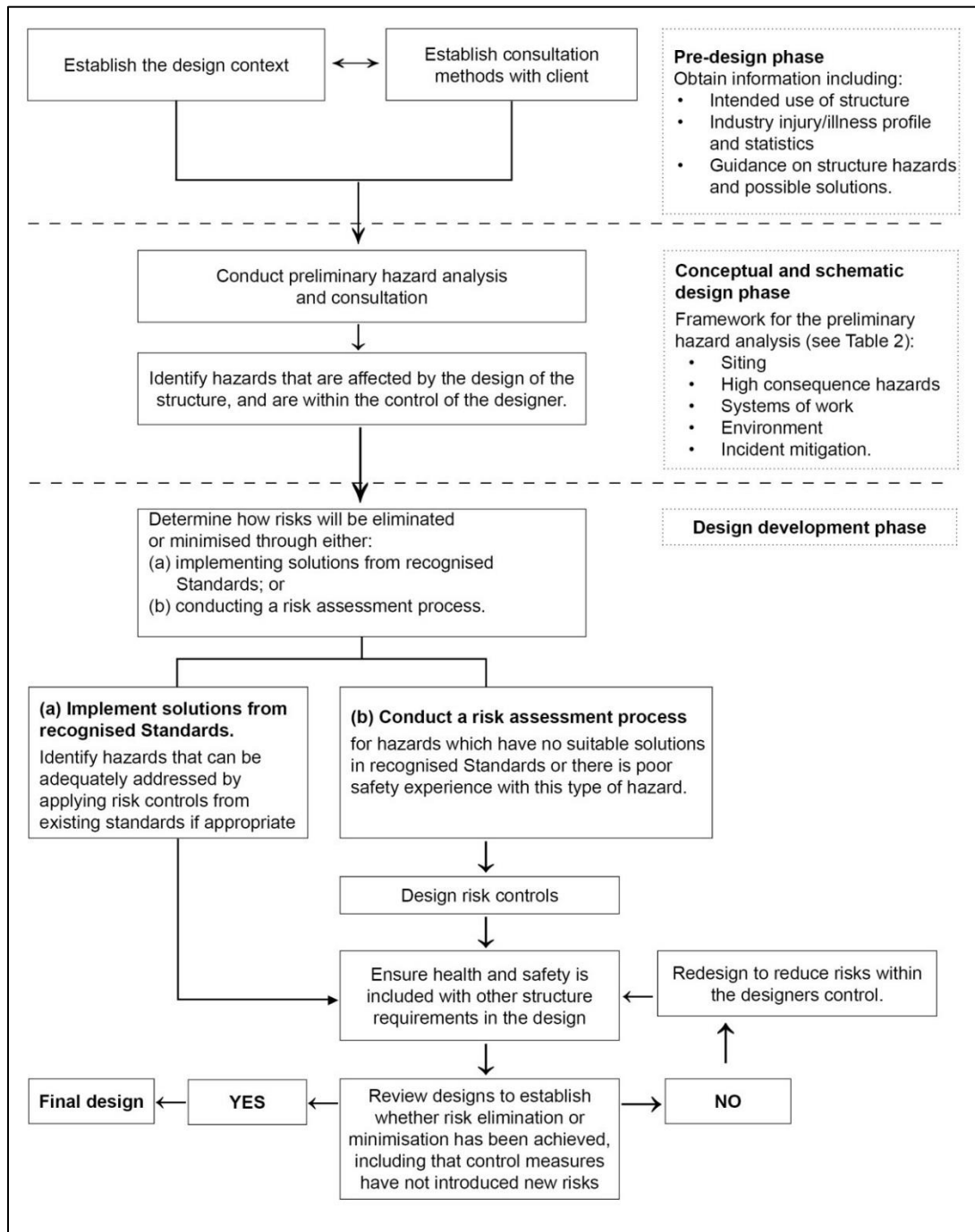

Figure 1: Safe design of structures. Code of practice (SafeWork Australia)

2.2.3 Review Process

The SiD review process throughout each stage of the project is defined in Figure 2.

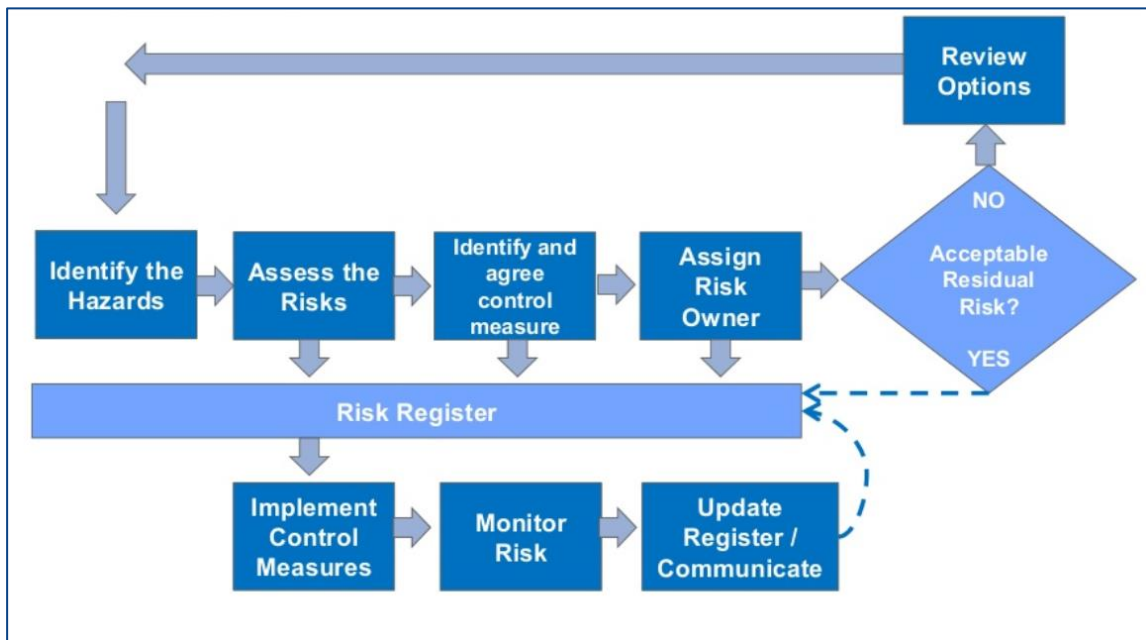

Figure 2: SiD review process (adapted from Hecker, 2011)

SiD reviews shall identify and control hazards and risks associated with the following:

- the range of work activities associated with the intended use of the building/structure as a workplace, including fixtures integral to its use as a workplace;
- any maintenance, repair, service and cleaning activities for the building/structure when it is in use; and
- the construction of the building/structure i.e. to make the design safer to build.

The designer shall identify and control hazards and risks associated with the above activities, and inform the University of any high risks in the University's design requirements, and recommend design alternatives that will eliminate or reduce risks arising from the original design.

Outputs from the SiD review shall include the following:

- A SiD review risk register for the design. The following information should be considered for inclusion (as appropriate):
 - design related hazards;
 - area/location of risk exposure; and
 - description of hazard and risk exposure, including existing design control measures;
- estimation of base risk i.e. risk level associated with the identified design-related hazard prior to the inclusion of any additional design control measures:
 - any additional design control measures;
- estimation of residual risk i.e. risk level associated with the identified design, including related hazards after the inclusion of any additional design control measures; and

- further actions.

The findings of the SiD review shall be provided to the University Project Manager, who will ensure that this information is provided to all relevant persons.

2.3 GENERAL

2.3.1 *Space and General Physical Layout*

The design of space and general physical places shall comply with relevant Legislation, Standards and Codes including but not limited to:

- National Construction Code
- AS 1428 (series): Design for access and mobility
- AS 1428.1: Design for access and mobility. General requirements for access – New building work
- AS 1657: Fixed platforms, walkways, stairways and ladders. Design, construction and installation
- [Ergonomic principles and checklists for the selection of office furniture and equipment](#) (Safe Work Australia)
- [Officewise – A guide for health and safety in the office](#) (WorkSafe Vic)
- [Compliance Code: Hazardous Manual Handling](#) (Worksafe Vic)

When designing for any workspace, it is critical to understand the scope of tasks undertaken in the workspace, the requirement for furniture, equipment and materials, and the way the users operate within their work environment.

Workplace design and layout should enable workstations to be accommodated in the safest configuration.

Space requirements should be based on an assessment that takes into account: the task, the physical actions needed to perform the task, the need to move around while working, whether the task is to be performed from a sitting or standing position, access to and egress from the workstation, the equipment to be handled and personal protective equipment that might have to be used.

The minimum clear circulation space for users to move and work safely between plant, equipment, structures and materials shall be 800 mm.

Work processes and the ergonomics of materials or manual handling tasks may justify clearance around workstation spaces to be increased.

Aisles, passageways and access to cupboards, storage or doors need to be in addition to the calculated clear workstation space. A clear space of 1000 mm is required in front of a cupboard or filing cabinet.

Minimum corridor widths shall comply with the National Construction Code and AS 1428.1 and generally requires:

- main spine corridors between buildings: 2400 to 2700 mm;
- primary corridors in buildings (main corridor linking rooms on a level): 1800 mm; and
- secondary internal corridors linking groups of rooms in a section of a level: 1500 mm.

Minimum recommended widths for disabled access ways is an unobstructed width of 1000 mm as outlined in AS 1428.1.

Lifts must be available and of an appropriate design and dimensions for transporting any required items between floors

Stairways and walkways must be designed in accordance with AS/NZ 1657.

2.3.2 Wall Fitments and Shelving

All wall-mounted fitments shall be designed to prevent personal injuries from failure of components. Where shelf units have weight limitations that can readily be exceeded, a maximum loading label shall be displayed.

Glass display cabinets, including glass doors, track and locking mechanisms, shall comply with all safety standards.

More detailed requirements for wall fitments and shelving is outlined in Section 2.6.7 and Section 2.6.8.

Refer to the Design Standard Section 1, *Planning and Architecture* for additional requirements.

2.3.3 Chemicals

All areas where chemicals (including hazardous substances, dangerous goods and scheduled poisons) are stored, handled and/or used shall comply with relevant Legislation, Standards and Codes including but not limited to:

- Occupational Health and Safety Act 2004 (Vic)
- Occupational Health and Safety Regulations 2017 (Vic)
- Dangerous Goods (Storage and Handling) Regulations 2012 (Vic)
- Drugs, Poisons and Controlled Substances Regulations 2017 (Vic)
- AS/NZS 1020: The control of undesirable static electricity
- AS 1345: Identification of the contents of pipes, conduits and ducts
- AS/NZS 1596: The storage and handling of LP Gas
- AS 1894: The storage and handling of non-flammable cryogenic and refrigerated liquids
- AS 1940: The storage and handling of flammable and combustible liquids
- AS/NZS 2022: Anhydrous ammonia - Storage and handling
- AS/NZS 2243.2: Safety in laboratories – Chemical aspects
- AS/NZS 2243.10: Safety in laboratories – Storage of chemicals
- AS 2507: The storage and handling of agricultural and veterinary chemicals
- AS 2714: The storage and handling of organic peroxides
- AS/NZS 2927: The storage and handling of liquefied chlorine gas
- AS 3780: The storage and handling of corrosive substances
- AS/NZS 3833: The storage and handling of mixed classes of dangerous goods, in packages and intermediate bulk containers
- AS 3961: The storage and handling of liquefied natural gas
- AS/NZS 4081: The storage and handling of liquid and liquefied polyfunctional isocyanates

- AS 4326: The storage and handling of oxidizing agents
- AS 4332: The storage and handling of gases in cylinders
- AS/NZS 4452: The storage and handling of toxic substances
- AS/NZS 4681: The storage and handling of Class 9 (miscellaneous) dangerous goods and articles
- AS/NZS 4757: Handling and destruction of drugs
- AS/NZS 5026: The storage and handling of Class 4 dangerous goods
- AS 4840: Low pressure regulators for use in industrial compressed gas reticulation systems
- [Compliance code. Hazardous substances](#) (Worksafe Vic)

In general, where chemicals are stored on shelves the following shall apply:

- the shelf height of shelves over benches shall not be more than 1.5 metres from the floor;
- the shelving systems shall include finishes that are compatible with the chemicals to be stored, or shall be suitably protected from them;
- the shelving systems shall be designed for the maximum holding capacity of the chemical packages.

2.3.4 Dangerous Goods Stores

Flammable Liquid Stores

Construction of the flammable liquid stores, including segregation requirements shall comply with relevant Legislation, Standards and Codes including but not limited to:

- AS 1940: The storage and handling of flammable and combustible liquids
- AS/NZS 2243.2: Safety in laboratories – Chemical aspects
- AS/NZS 2243.10: Safety in laboratories – Storage of chemicals
- AS 4326: The storage and handling of oxidizing agents

Where the use of flammable liquid indoor storage cabinets has been specified, attention is drawn to the provision within the AS 1940 and AS/NZS 2243.10 with respect to cabinet separation and ventilation, together with ignition source requirements.

An appropriate automatic fire extinguishing flood system shall be provided in accordance with current practice. Refer to Design Standard, Section 8, *Fire Protection and Detection Services* for further requirements.

Gas Cylinder Storage and Use

The construction of areas built for storage and handling shall comply with relevant Legislation, Standards and Codes including but not limited to:

- AS 4332: The storage and handling of gases in cylinders
- AS 4840: Low pressure regulators for use in industrial compressed gas reticulation systems
- AS 4289: Oxygen and acetylene gas reticulation systems
- AS 4603: Flashback arresters. Safety devices for use with fuel gases and oxygen or compressed air

- AS 4706: Pressure gauges for regulators used with compressed gas cylinders

Where reasonably practicable gas cylinders are stored outdoors with one or more sides, or a roof, open to the atmosphere. Storage shall be provided with the necessary segregation of gases as determined by AS 4332.

A means of securing cylinders against falling shall be provided.

Where stored in loading bay or other similar location where external damage from motor vehicles could occur, suitable protection of the structure and stored cylinders shall be provided (eg impact rated bollards).

Protection from sunlight shall be provided.

Where practicable, gas cylinders that are connected to consuming apparatus (such as a reticulated system) shall be located outside the building in accordance with AS 4332.

2.3.5 Portable Fire Extinguishers and Fire Blankets

The correct number and location of appropriate fire extinguishers and fire blankets shall be determined and documented and shall comply with relevant Legislation, Standards and Codes including but not limited to:

- AS/NZS 1841.1: Portable fire extinguishers. General requirements; and
- AS 2444: Portable fire extinguishers and fire blankets. Selection and location

The selection of fire extinguishers and fire blankets shall be guided by the Standards referenced above.

Health and safety factors and human factors as outlined in AS 2444 shall be considered.

The design consultant shall ensure that the supply and fixing of all extinguishers is documented in the main contract.

2.3.6 Safety Showers

These devices, and their actuating mechanisms, shall be located so that the approach to them is unobstructed and comply with AS 4775: Emergency eyewash and shower equipment. This shall include the following.

At least one safety shower shall be installed where chemical, corrosive or flammable substances are used. There shall be not more than 10 seconds to reach such devices from any point where the substance is used.

Note: This may be a drench-type shower, a hand-held spray, or other type as appropriate to the hazards of the laboratory.

2.3.7 Emergency Eye-Wash Stations

These devices, shall be located so that the approach to them is unobstructed and comply with AS 4775: Emergency eyewash and shower equipment. This shall include the following.

An eye-wash facility of appropriate type shall be installed in each room where chemical, corrosive, or flammable substances are used or handled. There shall be not more than 10 seconds to reach such devices from any point where the substance is used.

A permanently fixed aerated type, which can be operated without using hands, is preferred. Provision shall be made to drain or restrain any excess water from these devices.

2.3.8 Safety Signs

All safety equipment and facilities shall be clearly sign-posted and shall comply with relevant Legislation, Standards and Codes.

Where safety signs are required they shall conform to AS 1319: Safety signs for the occupational environment.

There should be provision of a notice board for highlighting safety issues.

Refer to the Design Standard Section 1, *Planning and Architecture* for additional requirements.

2.3.9 Asbestos and Hazardous Materials

Prior to commencing building works on any area of the campus the design team, or person sponsoring the work shall reference any existing, relevant asbestos/hazard audit information for the building or area by:

- referring to the University of Melbourne asbestos register (available through Infrastructure Services and the Hazardous Building Materials online compliance database; and
- using an auditable process, determined by WorkSafe Victoria, to verify the presence of asbestos-containing material (Occupational Health and Safety Regulations 2017[Vic]).

Generally, any known asbestos removal work shall occur prior to the letting of the construction contract, alternatively the works may be detailed and included in the contractor's tender. Options are at the University's Project Manager's discretion.

2.3.10 Heights

The design of internal and external locations where working at heights (or there is an opportunity to fall) shall comply with relevant Legislation, Standards and Codes including but not limited to:

- Occupational Health and Safety Regulations 2017
- National Construction Code
- AS/NZS 1891 (series): Industrial fall arrest systems and devices
- AS 5203: Protection of openable windows/fall prevention. Test sequence and compliance method

Access to roofs shall be restricted and available for authorised entry only.

It is preferable that fall prevention is included in all new designs (and refurbishments) that eliminate the requirement for passive fall prevention devices and/or fall arrest systems.

Where passive fall prevention devices are required, the layout and design incorporate suitable access for those devices.

Refer to the Design Standard, Section 5, *Building Fabric* for additional requirements.

2.3.11 Plant

The design of installations, commissioning and maintenance of plant shall comply with relevant Legislation, Standards and Codes including but not limited to:

- Occupational Health and Safety Regulations 2017
- AS/NZS 2243.6: Safety in laboratories. Plant and equipment aspects
- AS/NZS 4024.1601: Safety of machinery. Design of controls, interlocks and guarding – Guards – General requirements for the design and construction of fixed and movable guards
- AS/NZS 4024.1602: Safety of machinery. Interlocking devices associated with guards – Principles for design and selection

- AS 4024.1603: Safety of machinery. Design of controls, interlocks and guards – Prevention of unexpected start-up
- AS/NZS 4024.1604: Safety of machinery. Design of controls, interlocks and guarding – Emergency stop – Principles for design
- AS 4024.2601: Safety of machinery. Design of controls, interlocks and guarding – Two-hand control devices – Functional aspects and design principles
- AS/NZS IEC 60825.4: Safety of laser products. Laser guards

Refer to the Design Standard, Section 9, *Mechanical Services* for requirements.

2.4 IONISING RADIATION

2.4.1 *Ionising Radiation Control*

The design and subsequent working procedures within buildings shall comply with relevant Legislation, Standards and Codes including but not limited to:

- Radiation Act 2005 (Vic)
- Radiation Regulations 2017 (Vic)
- Radiation Protection Series 10. Code of Practice and Safety Guide - Radiation Protection in Dentistry
- Radiation Protection Series 11. Code of Practice for the Security of Radioactive Sources
- Radiation Protection Series 14. Code of Practice for Radiation Protection in the Medical Applications of Ionizing Radiation
- Radiation Protection Series 17. Code of Practice & Safety Guide for Radiation Protection in Veterinary Medicine
- Radiation Protection Series 19. Code of Practice for Radiation Protection in the Application of Ionizing Radiation by Chiropractors
- AS 2243.4: Safety in laboratories. Ionizing radiations

All facilities containing radioactive sources shall be identified by the appropriate signage outlined in the relevant Radiation Protection Series Code of Practice.

Appropriate shielding shall be provided that complies with the exposure limits (dose limits) as listed in the Radiation Regulations 2017 (Vic) and the University of Melbourne [ionising radiation management plan](#).

The University Services, Health & Safety team shall be consulted during the preparatory planning stages.

All radioactive sources shall be purchased and/or acquired after permission for their possession and use are included on the University of Melbourne Radiation Management Licence.

2.5 LABORATORIES

2.5.1 *General*

The design and subsequent use of laboratories shall comply with relevant Legislation, Standards and Codes including but not limited to:

- AS/NZS 2982: Laboratory design and construction
- AS/NZS 2243.1: Safety in laboratories. Planning

- AS/NZS 1680.1: Interior and workplace lighting. General principles and recommendations
- AS/NZS 2243 (series) Safety in laboratories
- AS 61010 (Series): Safety requirements for electrical equipment for measurement, control and laboratory use

A wide range of different laboratories exist in which a range of functions are carried out including research, quality control, testing, teaching and/or analysis. Whilst certain common design principles apply to all, the design and layout should be developed from a knowledge of the processes to be carried out, the space needed for each, and the desired work flow.

Consultants will work to specific briefs based on the functions to be accommodated - an array of physical sciences, computing, electronic and robotics in the case of dry laboratories; and biology, chemistry, biomedical and some engineering and materials science in the case of wet laboratories.

In all situations the functional needs of the user group must be considered. This can only be done by engaging the user group and undertaking a formal planning brief. AS/NZS 2982:1 outlines the requirement for a planning brief.

In teaching laboratories, a clear view of the lecturer, screens, boards, presentation materials and equipment should be possible from each workstation without the student having to adopt awkward or twisted postures.

Direct lighting must be adequate for the tasks being undertaken and achieve the level of illumination as specified in AS/NZS 1680.1. Generally, 300 to 600 lux is appropriate for laboratory applications.

Task lighting may need to be installed under shelves to supplement the ceiling lighting system.

Temperature, humidity and air quality should be designed to suit the requirements of the laboratory processes and instrumentation, or, in the absence of any special requirements, to provide acceptable user comfort and safety. Room ventilation should be in accordance with AS/NZS 2243.1 and AS/NZS 2243.3.

Where required, break out rest areas should be provided outside laboratories.

Laboratory workstations should be designed to accommodate the various equipment and materials used at them and permit optimal work postures during task performance. The appropriate height for a workbench therefore depends on the person's work posture (sitting/standing), the work activity (precision/light/heavy), the size/height of the materials and tools used and the elbow height of the individual. Adjustable height work surfaces should be considered for certain activities. Consultation with the user group should be undertaken to determine the nature of the work and the bench heights designed accordingly.

Figure 3 demonstrates the height level for bench work dependent on the activity. These heights are intended to accommodate most users in a standing posture however an adjustable height stool (and high footrest) should be provided to enable a seated option.

If an adjustable height work bench is supplied it should include the height range of 650 to 1200 mm above floor level.

Precision work, where elbow support is needed to reduce neck and shoulder muscle strain. Elbow height only be up to 50 mm above bench top.

Light work, such as pipetting, use of computer keyboard and mouse for data entry. Elbow height up to 100 mm above bench top.

Heavy work. requiring demanding downward forces or where large items of equipment/tools are used. Elbow height between 150 to 400 mm above bench top

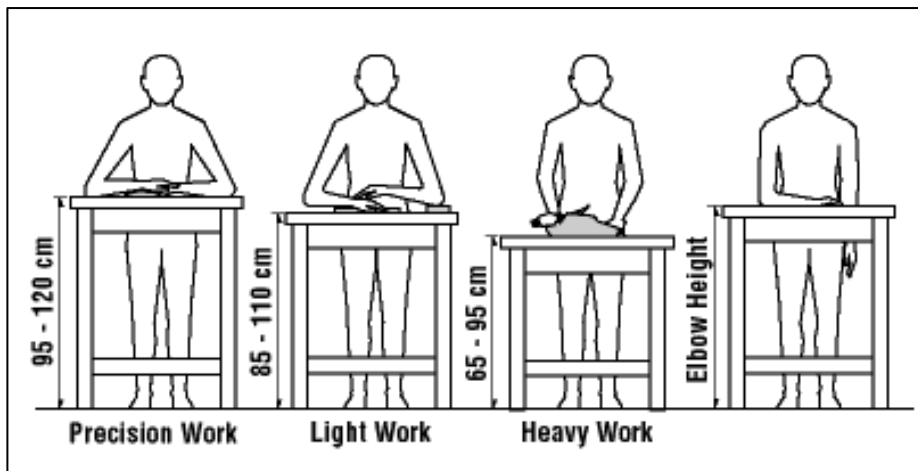

Figure 3: Bench height dependent on type of work

Workstations should be designed without fixed structures underneath to enable seated users to get their legs under and to enable cleaning

2.5.2 Wet Laboratories

In addition to the requirements listed in Section 2.5.1 the design and subsequent use of wet laboratories shall comply with relevant Legislation, Standards and Codes including but not limited to:

- AS/NZS 2243.3: Safety in laboratories. Microbiological safety and containment
- AS/NZS 2982: Laboratory design and construction
- AS/NZ 4586: Slip resistance classification of new pedestrian surface materials
- DAWR Approved arrangements biosecurity containment requirements

Wet laboratories may involve the use of hazardous materials and organisms and flammable substances that will require appropriate containment.

Floor surfaces must be stable, firm, smooth, impervious, easy to clean and be resistant to chemicals as well as have high slip resistance in accordance with AS/NZ 4586. Joins in slabs and/or openings in floors shall be avoided or designed and constructed in such a way that they are sealed against penetration by hazardous materials.

Wet laboratories generally require:

- Adjacency to apparatus, preparation and safe stores.
- Room configuration to suit layout of laboratory benches and related ancillary and research work spaces.
- All bench surfaces to be chemically resistant, with laminate to the underside and bullnose leading edges.
- Services combined and aligned vertically for efficient deployment.
- Wet activities as required, including biological and chemical agents.
- Sinks with integral drainers of high grade stainless steel at the end of bench runs.
- Suitable bench heights, with access for disabled staff and students. Adjustable, where possible, are to be considered.

- Under and over bench shelving and storage for chemicals, apparatus and equipment.
- Adjustable ergonomic laboratory stools and chairs with wet and chemical resistant impervious material (e.g. vinyl or rubber).
- Minimum of one single sided fume cupboard per wet laboratory. The final number and arrangement of fume cupboards shall be determined by project/users.
- Door entry mats or shoe bath facilities as required by laboratory PC rating.
- Magnetic or glass white boards, pin boards, smart boards as required.
- Projection screens, lecterns or other points of delivery, flexible equipment stations, as required.
- Blinds provided to external windows for brown-out as required.
- Splashback behind basins.
- Floor finish for industrial wet and corrosion resistance, with integral coving.
- Accessible, non-combustible, sealed ceiling grid for services.
- Observation window panels viewing in, out and between laboratory spaces, preparation rooms and so on.

At least one safety shower and emergency eye-wash station shall be installed where chemical, corrosive or flammable substances are used. See Section 2.3.6 and Section 2.3.7 for requirements.

Additional shower and emergency eye wash station requirements may apply in biocontainment facilities; the University Project Manager will advise.

Additional requirements must be considered when designing wet biological laboratories including:

- most biological laboratories will require Physical Containment Level 1 (PC1) as per AS/NZS 2243.3;
- more advanced laboratories may require Physical Containment Level 2 (PC2), Physical Containment Level 3 (PC3) or Physical Containment Level 4 (PC4) as per AS/NZS 2243.3; and
- where required, wet laboratories should be suitable for registration under the Office of Gene Technology (OGTR) and the Department of Agriculture and Water Resources (DAWR) such that the faculty/University can satisfy these regulators.

2.5.3 Dry Laboratories

Dry laboratories are general purpose spaces for practical teaching and learning. Dry laboratories generally do require plumbing, but on occasions may require a single plumbed service point for general use, preferably located adjacent to entry point.

Dry laboratories generally require:

- Direct adjacency to preparation and apparatus rooms and safe stores.
- Electrical services to island tables and benches is to be achieved where possible either through shallow ducts on floors or dropper ducts from the ceiling
- Robust benches constructed from inert material.
- Suitable and adjustable table and bench heights and/or stool and chair heights accessible for disabled staff and students.

- Sufficient storage, shelf space and cupboards for exhibits, samples, tools and partially completed Projects.
- Magnetic or glass white boards, pin boards, smart boards as required.
- Projection screens, lecterns or other points of delivery, flexible instruction stations as required.
- Blinds provided to external windows for brown-out as required.
- Accessible, non-combustible, ceiling grid for services.

2.5.4 Biological Safety Cabinets, Cytotoxic Drug Safety Cabinets and Fume Hoods

Where biological safety cabinets, cytotoxic drug safety cabinets and fume hoods are provided they shall be designed, sited, constructed and installed and shall comply with relevant Legislation, Standards and Codes including but not limited to:

- AS 2252.4: Controlled environments. Biological safety cabinets Classes I and II – Installation and use
- AS 2252 (Series): Biological safety cabinets
- AS 2252.5: Controlled environments – Cytotoxic drug safety cabinets (CDSC) – Design, construction, installation, testing and use
- AS/NZS 2243.1: Safety in laboratories. Planning
- AS/NZS 2243.3: Safety in laboratories. Microbiological safety and containment
- AS/NZS 2243.8: Safety in laboratories. Fume cupboards

Biological Safety Cabinets, cytotoxic drug safety cabinets and fume hoods should be designed and installed at an appropriate height so that so that the user can adopt optimal work postures and movements during task performance. There should be no fixed panels or cupboards underneath preventing the user getting close to the work when sitting or standing.

Consider installing an adjustable height table rather than a fixed cabinet.

2.5.5 Microscope Workstations

Where microscopes are installed consider cut-out work tables which provide an area for supporting the forearms while using adjustment knobs. The microscope should be elevated and angled appropriately to enable the user to look directly into the eyepiece whilst maintaining an optimal posture.

Microscope workstations should be designed and installed at an appropriate height so that so that the user can adopt optimal work postures during task performance. There should be no fixed panels or cupboards underneath preventing the user getting close to/legs under the work when sitting at the microscope.

2.6 HUMAN FACTORS AND ERGONOMICS

2.6.1 Background

This section provides details of minimum requirements for human factors and ergonomic design in interior environments and shall be considered an adjunct to all relevant statutory regulations.

Incorporating ergonomics and human factors into the design of buildings, structures and internal fit outs and all aspects of the worker/work interface ensures the physical and psychosocial needs of a broad range of users including those with special needs are

comfortably accommodated and injury risk is minimised. Ergonomic principles should be applied in the early stages of design and not just when a building is being outfitted.

This section has been prepared with consideration to:

- relevant Australian Standards, industry standards, codes and publications;
- scientific data e.g. human body dimensions data (anthropometry) and biomechanics; and
- evidence based research and best practice

As each project will present a range of different design challenges, and some projects will have unique and specialised requirements it is not possible to cover all specifications for all scenarios. The designer is expected to produce their own specification incorporating the elements of the following information and submit all designs to the University for review prior to any tendering or works commencing on site.

Consultation with University Services, Health & Safety team and the client/user group shall occur to determine their specific work requirements to ensure that optimum design and usability outcomes are achieved.

It is expected that all furniture, fittings and equipment are sourced from the University's panel of preferred suppliers.

The University of Melbourne will endeavour to make any reasonable adjustments to accommodate users with special needs.

2.6.2 Space and General Physical Layout

The design of space and general physical shall comply with relevant Legislation, Standards and Codes including but not limited to:

- National Construction Code
- AS 1428 (series): Design for access and mobility
- AS 1428.1: Design for access and mobility. General requirements for access – New building work
- AS 1657: Fixed platforms, walkways, stairways and ladders. Design, construction and installation
- [Ergonomic principles and checklists for the selection of office furniture and equipment](#) (Safe Work Australia)
- [OfficeWise – A guide for health and safety in the office](#) (WorkSafe Vic)
- [Compliance code: Hazardous manual handling](#) (Worksafe Vic)

When designing for any workspace, it is critical to understand the scope of tasks undertaken in the workspace, the requirement for furniture, equipment and materials, and the way the users operate within their work environment.

Workplace design and layout should enable workstations to be accommodated in the safest configuration.

Space requirements should be based on an assessment that takes into account: the task, the physical actions needed to perform the task, the need to move around while working, whether the task is to be performed from a sitting or standing position, access to and egress from the workstation, the equipment to be handled and personal protective equipment that might have to be used.

The minimum clear circulation space for users to move and work safely between plant, equipment, structures and materials shall be 800 mm.

Work processes and the ergonomics of materials or manual handling tasks may justify clearance around workstation spaces to be increased.

Aisles, passageways and access to cupboards, storage or doors need to be in addition to the calculated clear workstation space. A clear space of 1000 mm is required in front of a cupboard or filing cabinet.

Minimum corridor widths shall comply with the National Construction Code and AS 1428.1 and generally requires:

- main spine corridors between buildings: 2400 to 2700 mm;
- primary corridors in buildings (main corridor linking rooms on a level): 1800 mm; and
- secondary internal corridors linking groups of rooms in a section of a level: 1500 mm.

Minimum recommended widths for disabled access ways is an unobstructed width of 1000 mm as outlined in AS 1428.1.

Lifts must be available and of an appropriate design and dimensions for transporting any required items between floors

Stairways and walkways must be designed in accordance with AS/NZ 1657.

2.6.3 **Light and Lighting**

The type and placement of lighting shall consider the tasks being undertaken and shall comply with relevant Legislation, Standards and Codes including but not limited to:

- AS/NZS 1680.0: Interior lighting. Safe movement
- AS/NZS 1680.1: Interior and workplace lighting. General principles and recommendations
- AS/NZS 1680.2.1: Interior and workplace lighting. Specific applications – Circulation spaces and other general areas
- AS/NZS 1680.2.2: Interior and workplace lighting. Specific applications – Office and screen-based tasks
- AS/NZS 1680.2.3: Interior and workplace lighting. Specific applications – Educational and training facilities
- AS/NZS 1680.2.4: Interior lighting. Industrial tasks and processes
- AS/NZS 1680.2.5: Interior lighting. Hospital and medical tasks

Lighting must be adequate for the tasks being undertaken. Lighting installation should be installed at the appropriate distances to ensure evenness, comfortable visibility and no shadows at task viewing level.

AS/NZS 1680.1 provides specific guidance on recommended maintenance illumination levels for various workplaces, activities and interiors.

The key principals for lighting design include:

- **design for the task** which includes understanding the tasks and activities performed; and
- **select the appropriate** type and number of luminaires for the work being done including:
 - artificial lighting should most closely resemble natural light

- down lights if used should be fitted with baffle trims – sufficient numbers are required to ensure light is distributed evenly across the work surfaces
- batten lights fitted with diffusers are effective in delivering even illumination
- indirect or uplighting systems can be effective in workplaces as they direct all light to the ceiling eliminating shadow and glare
- fixtures should be designed so bare or exposed lamps should not be visible to the eye

Control direct lighting by using dimmers, glare filters, diffusers, baffles (to reduce, redirect, soften light sources).

Control external light sources using suitable blinds. Blinds should be selected according to the level of sunlight entering the window. The best solution is to combine a partially transparent sunscreen blind with a block-out blind. Ensure operating cords are accessible without having to climb or reach excessively and cords can be secured with either tie-downs (cleats) or tension devices that enclose cords and chain loops

Locate workstations or work points so that luminaires are parallel with the worker's line of sight and not in front of, or behind or directly overhead.

Change lighting levels gradually. Sudden contrasts in light levels e.g. coming out of a well-lit area into a dark area or vice versa can be a problem because it takes the eye several seconds to adapt to new lighting conditions.

Minimise glossy reflective surfaces. Sources of light 'bounce' and create sources of glare. This includes glossy display monitors, glass partitioning, windows with a privacy treatment applied (two-way glass), whiteboards, keyboards etc.

Walls should have 50 to 75% reflectance and a matte finish, ceilings should preferably be white reflecting approximately 80% of light. Avoid black ceilings with mounted lights as they create a high contrast which is fatiguing for the eyes

Portable desktop task lamps where used should have a flexible arm and head, cast light evenly over the length of the workspace, effective heat dispersion and dimming capability

Low hanging pendant or suspended lights should be generally avoided as they can create pools of direct light. With the move to sit/stand workstations greater proximity to the light source can result in a glare source in the visual field.

Refer to the Design Standard Section 7, *Electrical, Services* for emergency lighting requirements.

Refer to the Design Standard Section 5, *Building Fabric* for additional requirements.

2.6.4 Noise

Damaging noise and nuisance noise shall comply with relevant Legislation, Standards and Codes including but not limited to:

- Occupational Health and Safety Regulations 2017 (Vic)
- Compliance Code. Noise (Vic)
- AS/NZS 1269: Occupational noise management. Noise control management
- AS/NZS 2107: Acoustics. Recommended design sound levels and reverberation times for building interiors
- AS2822, Acoustics: Methods of assessing and predicting speech privacy and speech intelligibility

Where hard surfaces that reflect noise (e.g. timber and glass) are used extensively, consideration should be given to the installation of sound absorbing structures or materials.

Noisy printing or photocopying equipment should be isolated in separate rooms with adequate ventilation.

Refer to the Design Standard, Section 12, *Acoustics, Vibration and EMI* for additional noise requirements.

2.6.5 Thermal Comfort and Air Quality

Temperature and air quality levels must be well controlled and/or regulated and shall comply with relevant Legislation, Standards and Codes including but not limited to:

- AS 1668.2: The use of ventilation and air conditioning in buildings. Mechanical ventilation in buildings

The recommended ambient office temperature is 20 to 25°C. Perception of thermal comfort will vary between individuals.

Avoid locating workstations directly in front of or below air conditioning outlets.

For internal environments the following is recommended:

- control direct sunlight (radiant heat) with blinds;
- install air conditioning units with draught control technology providing flat air-flow directed along the ceiling;
- insulate/enclose hot processes and locate them away from people;
- install shields or barriers to reduce radiant heat from heat sources;
- install shade cloth to reduce radiant heat from the sun;
- minimise draughts between the head and feet (thermal gradients); and
- maintain an airflow rate between 0.1 and 0.2 metres per second.

Refer to the Design Standard, Section 10, *BAS and Controls* for additional requirements.

2.6.6 Flooring and Pedestrian Surfaces

Flooring and pedestrian surfaces must be suited to the location and the work undertaken and shall comply with relevant Legislation, Standards and Codes including but not limited to:

- National Construction Code
- AS 1428.2: Design for access and mobility. Enhanced and additional requirements - Buildings and facilities
- AS/NZS 4663.2004 Slip resistance measurement of existing pedestrian surfaces
- HB 197 An introductory guide to the slip resistance of pedestrian surface materials

In all circumstances the selection of floor coverings shall take the work processes into account. Some work processes create hazardous floor conditions, such as spillages, (e.g. grease, water, food, or body fluids or off-cuts of materials), which can create slip and trip risks.

Floor coverings also need to be selected for hygiene and for their lack of resistance to push/pull forces exerted by employees on mobile equipment.

Low slip resistant floors e.g. polished concrete, timber or tiles should not be selected for administrative areas where chairs with castors will be used.

Floor surfaces should be designed to minimise impact noise.

Refer to Design Standard, Section 5, *Building Fabric* for requirements on approved carpets.

Consideration should be given to supplying floor insulation at workstations where employees are required to stand on concrete, masonry or steel floors.

Anti-static vinyl/marmoleum shall be considered for wet, dry and electronic laboratories and information technology/communications rooms.

Entrance matting shall be provided to doors at the entrances to buildings and should be aluminium, and limit ingress of dirt, debris, water and mud and be of a light weight to enable easy removal and cleaning by one person.

All external surfaces around and between buildings should provide a consistent, even, slip resistant pathway, with suitable drainage and shelter/coverage where required. Rough, raised surfaces, uneven paving and changes in level should be avoided.

Surfaces that become slippery when wet – e.g. pebbles, tiles, some painted timbers, or affected by wet leaves, moss, sand or gravel should not be selected.

Refer to the Design Standard, Section 1, *Planning and Architecture* for additional requirements.

2.6.7 Storage Systems – Shelving, Racking and Compactus

Shelving and Racking

Storage shelves must be robust, stable and well secured. Bookcases should generally be no higher than 2100 mm however if higher must be fixed to the wall

Shelving should be designed so heavier and more frequently used items can be located within the optimal reach zone- shoulder to mid-thigh range. Only light items (easily lifted with one hand) should be stored above shoulder.

Higher shelving must accommodate a safe means of climbing to the required level of storage. ie. sufficient space to use (and store) an approved step ladder.

Where applicable (eg pallet racking) the specified safe working load (SWL) shall be clearly visible.

Refer to the Design Standard, Section 1, *Planning and Architecture* for additional requirements.

Compactus

All compactus storage units shall be designed and supplied to minimise risk of entrapment between bays during operation. An effective engineering method of lock-out must be specified provided.

The minimum aisle width within the compactus system shall be 600 to 700 mm.

The compactus should not require significant operating force.

Large, multiple bay compactus models, electric motors with keypad controls shall be fitted to eliminate the manual effort of moving multiple bay stacks.

Small compactus units should have a large handle permitting a 2-handed grip positioned at approximately chest level. This reduces the risk of one hand being placed on the edge of the unit where it can become caught between units. It also reduces the likelihood of pulling the unit behind the shoulder which is a typical (and risky) practice when a small handle is fitted.

Medium size compactus units should have a drive wheel fitted to greater allow mechanical advantage.

The size and placement of winding mechanisms, handles or wheels to open and close compactus should not present an entrapment hazard for hands.

Compactus units shall not have raised platforms or rails which create a trip hazard or inhibit trolley movement, or, deep tracks which trap debris and affect movement of bays.

2.6.8 Storage Systems – Mobile and Standalone

Mobile and standalone storage systems must be suited to the location and the work undertaken and shall comply with relevant Legislation, Standards and Codes including but not limited to:

- AS 5079.1: Filing cabinets. Lateral filing cabinets
- AS 5079.2: Filing cabinets. Vertical filing cabinets
- AS 5079.3: Filing cabinets. Mobile pedestals

All small storage units shall be constructed of sturdy materials and positioned on a level floor to ensure that the drawers/doors open and close easily and do not tip when doors or drawers are open.

Stationery items and office supplies should be located in accessible and well-designed storage cupboard with provision for heavier items such as paper reams to be stored between chest and thigh zones.

Filing Cabinets and Lockers

Filing cabinets and lockers should not be located where they encroach into walkways.

Filing cabinets require approximately 1200 mm of space in front of them to enable the bottom drawer to be fully opened and accessed.

Filing cabinets must be on a level floor to ensure that the drawers open and close easily. They should be secured to the wall or floor to ensure that they do not tip when the top drawer is open.

The location of lockers should be decided according to the size and weight of the stored items and the frequency of use.

Mobile pedestal units and deep storage caddy units

Mobile pedestal units designed to sit under electric sit/stand desks shall be of a height that they do not impede the movement of the desk to its lowest height range of 650mm-measured from floor to top of desk.

Deep storage caddy units which extend out from under the desk with storage shelving located in the side of the unit (under the desk) should be avoided. They are often selected to provide a seated surface. These encourage the adoption of awkward body postures when accessing stored items.

2.6.9 Doors and Handles

Doors and handles must be suited to the location/placement and consider the environment and shall comply with relevant Legislation, Standards and Codes including but not limited to:

- National Construction Code
- AS 2047: Windows and external glazed doors in buildings
- AS 4145 (series): Locksets and hardware for doors and windows

- AS 5007: Powered door for pedestrian access and egress
- AS 6905: Smoke doors
- AS 1905: Components for the protection of openings in fire-resistant walls. Fire-resistant door sets

Refer to the Design Standard, Section 5 *Building Fabric* for additional requirements.

Doors

Building entrance and high traffic doors shall be automated wherever possible preferably bi-parting sliding glass doors.

Doors shall not open directly into a primary or secondary path of travel. If a door is required to do so to meet fire egress or other Code requirements, an appropriate recess or protection shall be provided.

Force requirement to open and close any manual doors shall not exceed 2 kg/f or 20 N.

Inward opening swing doors should be installed where there is sufficient space.

Sliding doors should be installed where there is limited space.

Door closers shall be tensioned to provide time for individuals with mobility impairment to move through and not give rise to entrapment hazards.

Double doors may be required to enable installation or passage of large pieces of equipment, materials, artwork or instruments.

Doors through which trolleys move must have a means of being secured open.

Solid high traffic doors and entry doors including teaching, learning, research and meeting rooms shall be fitted with glazed viewing panels. Where there are double doors a glazing panel is to be installed in at least one door leaf. The size of the panel shall ensure visibility for everyone, including wheelchair users.

Handles

“D” type lever door handles with a 30 to 50 mm circumference and 50 mm clearance (aperture) should be selected for all swing doors and located between 900 and 1100 mm above floor height.

A long vertically placed door handle with 30 to 50 mm circumference from approximately 700 to 1100 mm above floor height is acceptable on a sliding door

Avoid handles with square profile or sharp edges or other surface features, large circular or other unusual shapes.

Door handles should be positioned well away from door jambs to prevent trauma to the knuckles.

2.6.10 Desks – General Requirements

Desks must be suited to the location and the work undertaken and shall comply with relevant Legislation, Standards and Codes including but not limited to:

- AS/NZS 4442: Office desks
- AS/NZS 4443: Office panel systems. Workstations
- Relevant AFRDI Standards and certification

Certification to AFRDI (Australian Furniture, Research and Design Institute) should be requested from the manufacturer/supplier.

A range of desk designs are available including rectilinear, L shape or corner, curved 120-degree, round, kidney shape, or other versions. Both fixed height and adjustable are available. Manual height adjustable desks should be avoided. When selecting desks consideration shall be given to the purpose of the space, the intended user group, the tasks they undertake and equipment they require. In open plan offices and teaching spaces desks and tables are often arranged in clusters or pods.

Depth: 750 to 800 mm. This is necessary for appropriate monitor positioning in relation to focal distance and to enable sufficient space for a document holder between the keyboard and monitor should this be required

Length: Depends on desk design and tasks undertaken – Unless a need is established 1800 mm is preferred. Anything less will not comfortably accommodate 2 monitors or an under desk mobile pedestal unit. Lateral clearance under the desk to accommodate thigh width and leg/chair movement: 800 mm minimum (400 mm either side of navel). There should not be a frame or cable tray or other structure to encroach into this zone

Desk top thickness: Between 25 mm and 33 mm. This must be preserved to a depth of 450 mm minimum under desk at knee height and 600 mm minimum at feet level (120 mm above floor level). No frame or cable tray or other structure to encroach into this zone.

Cable management managed in cable tray and neatly loomed

Soft wiring: Desk top mounted power rail – power and data points -located at rear (either end) of desktop – a not in the centre which will interfere with monitor arm clamping.

Modesty panel: Fitted to rear of desk- commencing no higher than 400 mm above floor height

Load tolerance: Minimum 150 kg.

Desk surface: light colour, matte, non-reflective.

Desk finish: all desks should be free of sharp edges, corners, points or protrusions.

2.6.11 Desks – Sit/Stand

Sit/stand desks enable height variation and accommodate staff with special needs including staff in wheelchairs.

The height adjustment provides for the range of 650 to 1250 mm measured from floor level to finished desktop.

Sit/stand desks should be fitted with anti-collision technology.

Clearance (gap) between rear of desk and partition/screen: 25 mm across the length to accommodate flexible clamping of a monitor arm/s if required.

Clearance: minimum 30 mm between desks positioned side by side to eliminate risk of hand entrapment

Programmable height functionality feature: capacity to pre-set preferred sit/stand heights.

All other dimensions and features as specified in Section 2.6.10.

2.6.12 Desks – Fixed Height Seated

Height: 720 mm measured from floor level to finished desktop. A small level of height adjustment (manual/technician enabled) is preferable (650 to 735 mm).

All other dimensions and features as specified in Section 2.6.10.

2.6.13 Fixed Height Standing

Less preferred as fixed height standing desks offer limited flexibility for user size variation. They should be used in conjunction with a drafting stool as prolonged static standing is not recommended – refer to Section 2.7 for seating specifications.

Height: 1000 mm measured from floor level to finished desktop. A small level of height adjustment (manual/technician enabled) is preferable (900 to 1100 mm)

All other dimensions and features as specified in Section 2.6.10.

2.6.14 Computers (PC), Laptops and Monitor Arms

Desktop Computer (PC)

The hard drive should be located under (to one end) of the desk in a CPU holder. If a laptop is used it should be docked and secondary monitor(s) and computer peripherals (keyboard and mouse) made available.

Laptop

The laptop should be used with a suitable laptop riser and a separate keyboard and mouse. Purpose built docking stations should be used where the laptop is primarily used.

Monitor Arms

Monitor arms are preferred for flexibility of monitor positioning.

Single monitor arms clamped to the rear of the desk are recommended. Dual monitor capacity arms are not recommended as they do not permit use of monitors in a preferred primary and secondary configuration.

2.6.15 Tables

Tables-should be smooth, light in colour and a non-reflective, matt or satin finish.

Fixed height tables designed for sitting to engage in learning activities should have a height range of 720 mm measured from floor level to top of table.

Fixed height benches, bars designed for standing or sitting at a high drafting stool to work should have a height range of 900 to 1100 mm measured from floor level to top of bench.

All tables and benches should be a maximum of 33 mm thick and have no frame encroaching into the leg space to a depth of 450 mm.

Folding or flip tables must have instructions for folding, no entrapment points or sharp corners or edges and move easily

Castors on tables must be durable and lockable.

2.7 SEATING SPECIFICATIONS

2.7.1 Chairs – General Requirements

The type and purpose of the chair and seating arrangements must be considered and shall comply with relevant Legislation, Standards and Codes including but not limited to:

- AS/NZS 4088.1: Specification for burning behaviour of upholstered furniture. Upholstery materials for domestic furniture - Smouldering ignitability
- AS/NZS 4438: Height adjustable swivel chairs
- AS 4688.2: Furniture. Fixed height chairs – Determination of strength and durability

- Relevant AFRDI Standards and certification
- [Ergonomic principles and checklists for the selection of office furniture and equipment](#) (Safe Work Australia)

General requirements for chairs/seating include:

- a stable base.
- a load rating to a minimum 100 kg.
- an underframe e.g legs, castors that does not protrude more than 120 mm beyond the outermost dimension of the chair seat (including arms if present) so as to cause a trip hazard.
- no sharp projections, or other features that constitute a risk to users. There should be no sharp edges, rough surfaces or features that may trap clothing or cause injury. The ends and feet of tubular metal components shall be capped or closed and finished smoothly.
- covering materials and filling materials that meet burning behaviour performance requirements as set out in AS/NZS 4088.1.
- permanently marked with the manufacturers /importers name and address and year of manufacture and care, flammability and summarised operating details
- certification to AFRDI (Australian Furniture, Research and Design Institute) shall be provided by the manufacturer/supplier.

2.7.2 Staff Computer Workstation Chairs

Requirements for computer workstation chairs include:

- Five-star base with castors, swivel mechanism, waterfall edge design.
- Four-lever independent adjustment –seat height, back rest height, seat and back rest tilt, seat depth slide.
- Medium size seat base and backrest standard but options must be available to accommodate larger and smaller staff.
- Seat height adjustability range 400 to 550 mm. Options for alternative gas struts to be available.
- Back rest tilt range approximately 45 degrees.
- Arm rests (adjustable height) not routinely required but chair must have provision for arm rests.
- Meet the requirements of AS 4438 and AFRDI certified level 5 or 6.
- Smaller and larger, deeper seat pans shall be provided to accommodate smaller and larger users. Numbers shall be determined in consultation with the client department and the University Project Manager.

2.7.3 Student Task Chairs

Requirements for student task chairs include:

- Where students are working on computers or other portable electronic devices:
- Two-lever independent adjustment – seat height and back rest height.
- Seat height adjustability range 400 to 550 mm.

- Medium size seat base and backrest.
- Arm rests optional.
- Meet the requirements of AS 4438 Functional classification Type 2 and AFRDI certified level 5 or 6.

2.7.4 Meeting Room, Interview/Consulting Room Chairs

Requirements for meeting room, interview/consulting room chairs include:

- Five-star base with castors, swivel mechanism, waterfall edge design.
- Back rest tilt adjustment.
- Seat height adjustable.
- Medium size seat base and backrest standard but options must be available to accommodate larger and smaller staff.
- Arm rests.
- Meet the requirements of AS 4688.1 and AFRDI certified level 4 or 5.

2.7.5 Staff High Office Workstation/Counter Stools

Requirements for staff high office workstation/counter stools include:

- Where staff are working on reception, customer service counters and library desk counters:
 - Five-star base with castors, swivel mechanism, waterfall edge design.
 - Glides or soft tyre (rubber) castors with pressure locks fitted to 2 to 3 castors.
 - Four-lever independent adjustment – seat height, back rest height, seat and back rest tilt, seat depth slide.
 - Height adjustability range 650 to 780 mm.
 - Arm rests (adjustable height) preferred to assist transfer on/off.
- Meet the requirements of AS 4438 Functional classification Type 1 and AFRDI certified level 5 or 6.
- Smaller and larger, deeper seat pans shall be provided to accommodate smaller and larger users. Numbers shall be determined in consultation with the client department and the University Project Manager

2.7.6 Student High Office Workstation/Counter Stools

Requirements for student high office workstation/counter stools include:

- Where workstation height range is approximately 900 to 1000 mm:
 - Five-star base with castors, swivel mechanism, waterfall edge design
 - Two-lever independent adjustment – seat height, back rest height
 - Seat height adjustability range 650 to 780 mm
 - Glides or soft tyre (rubber) castors with pressure locks fitted to 2 to 3 castors.
 - Arm rests (adjustable height) preferred to assist transfer on/off.
- Meet the requirements of AS 4438 and AFRDI certified level 5 or 6.

2.7.7 Wet Laboratory Chairs

Requirements for wet laboratory chairs include:

- In wet laboratories for both staff and students with a workstation height range approximately 900 to 1000 mm:
- Five-star base with castors, swivel mechanism, waterfall edge design
- Four-lever independent adjustment –seat height, back rest height, seat and back rest tilt,
- Medium size seat base and backrest standard but options must be available to accommodate larger and smaller staff
- Height adjustability range 650 to 780mm
- Glides or soft tyre (rubber) castors fitted with castors with pressure locks fitted to 2-3 castors.
- Non-permeable (closed cell) upholstery.
- Arm rests (adjustable height) preferred to assist transfer on/off.
- Options for sit/stand or saddle stools for laboratory seating should be considered.
- Meet the requirements of AS 4438 1 and AFRDI certified level 5 or 6.

2.7.8 Examination Room/Seminar Room and Events Chairs

Requirements for examination room/seminar room chairs include:

- For staff, students and others (eg general public):
- Non-adjustable, 4 legs, no arms
- Lightweight <10 kg for ease of moving
- Stackable and moveable with trolley
- Meet the requirements of AS 4688.1

2.7.9 Occasional Seating/Chairs

Requirements for occasional seating/chairs include:

- Used for a wide range of applications such as public spaces, waiting rooms and cafes. Seating may include sofa's, arm chairs, stools, ottomans. Seating shall include the following:
- Stable with load rating to 100 kg
- No sharp edges, points or entrapment/pinch points
- Front edge of seat well rounded to avoid compression
- If the intention is to move the seating, a safe method of moving needs to be defined
- Consideration to seat height in relation to table height where it is to be used at a table or bench/bar. Seat height should ensure clearance for knees of largest users 250 mm gap is sufficient
- Options of seating with armrests for users with restricted mobility.
- The following features are also desirable:
- Cushioning on the seat, backrests and armrests (if present)

- No horizontal strut/leg between the front legs of the chair preventing placement of the feet beneath the centre of gravity
- Seat depth should allow users to get benefit from the back support without slouching
- approximately 400 to 450 mm
- Backrest (if present) angle and shape should offer lumbar support
- Seat height should be selected to minimize pressure under thighs- approximately 400 to 450 mm.
- Seat height at a high bench/bar should be approximately 675 to 725 mm and a foot bar should be fitted.

2.7.10 Lecture Theatre Seating

Requirements for lecture theatre seating include:

- Seating shall include the following:
- Stable with load rating to 100 kg
- No sharp edges, points or entrapment/pinch points
- Front edge of seat well rounded to avoid compression
- Consideration should be given to seat height in relation to foldable tablet. Seat and tablet height should ensure clearance for knees of largest users. Tablet height from floor level between 650 to 700 mm
- Tablet arms should be fold down and easy to operate. They must be robust and be free of sharp projections, rough surfaces or features that could cause entrapment of clothing or body parts. They must be of sufficient dimensions to accommodate a tablet or lap top.
- Options of seating with armrests for users with restricted mobility.
- The following features are also desirable:
- Seat height should be selected to minimize pressure under thighs- approximately 400 to 450mm.
- Seat depth should allow users to get benefit from the back support without slouching approximately 400 to 450mm
- No horizontal strut/leg between the front legs of the chair preventing placement of the feet beneath the centre of gravity.
- Backrest angle and shape should offer lumbar support.

2.8 DESIGN AND LAYOUT OF COMMON AREAS

The design and layout of common areas should consider the functions and activities of the area. The design and layout shall comply with relevant Legislation, Standards and Codes including but not limited to:

- National Construction Code
- AS1668.2: The use of ventilation and air-conditioning in buildings. Mechanical ventilation in buildings
- Officewise – A guide for health and safety in the office (WorkSafe Vic)

For each subsection below also refer to the Design Standard Section 1, *Planning and Architecture* for additional requirements.

2.8.1 Office Design and Layout

Offices vary from multistorey open plan floor layouts to small rooms in terrace houses. Office design should incorporate flexibility of layout, environment, furniture and equipment to suit the functional needs of the users – i.e. tasks and equipment. Providing adequate space in an office for people to operate effectively is essential.

Three types of space need to be considered:

- Primary space- amenities, meeting rooms, lift lobbies and similar areas
- Secondary space- corridors and storage
- Tertiary space – space required in a workstation to accommodate a desk, chair, drawers, filing cabinet, and other necessary equipment

A functional analysis of the needs of workers in modern offices reveals a minimum of 6 square metres per person is required for tertiary space with additional space for secondary and primary purposes. AS 1668.2 recommends an overall 10 square metres per person for building ventilation purposes. In all situations the functional needs of the user –personal space, technology needs, requirement for other equipment and materials, visitors, meeting chairs etc. must be considered.

Office Workstation Layout

The design of office layout includes the following:

- Distance between heads: minimum 1500 mm to allow adequate functional, mobility and personal space requirements.
- Distance (clearance) between rows of linear desks: minimum 2000 mm measured between front edges of desks.
- Clearance above desks: A clear space of 700 mm above the height of the desktop must be preserved for unimpeded movement of monitor.

Fixed over desk cabinetry/joinery should be avoided.

Copy machines and equipment should recycle toner, use sealed toner cartridges and waste containers, filter exhaust air, emit minimal noise and automatically collate and staple. They should be in a well ventilated and accessible area – not in walkways or obstructing exits. Adequate space for operation and maintenance access must be available.

2.8.2 Meeting Rooms

Meeting rooms vary greatly in size and design and should provide an effective environment for discussion and presentations with adequate acoustic privacy to protect confidentiality and minimise disturbance to surrounding spaces.

- Enough meeting rooms and sizes shall be supplied to allow for groups to conduct meetings.
- Materials used should facilitate dampening of noise. Extensive use of glass and hard surfaces should be avoided unless accompanied by sound absorbing mediums around them.
- Where activities such as hand writing and lap top use are undertaken at a fixed seated height meeting room table, the table height shall be 720 mm measured from floor level to top of table with a maximum desktop thickness of 33 mm and a light, non-reflective,

matte finish. All other dimensions (depth and length etc.) should be determined by the room size and function.

- Select meeting room chairs with features outlined in meeting room selection.

2.8.3 Reception Desks/Service Counters

Reception desks and service counters can vary from fixed joinery to adjustable height. In all situations the functional needs of the user group –tasks, equipment and materials, customers, visitors etc. must be considered. Counter design includes the traditional ‘across counter’ models and side by side models.

Counter design shall comply with the following:

- Have a minimum of 1000 mm circulation space behind the counter to allow users space to move, access drawers etc. This may be significantly greater in the case of library service counters where there may be a requirement to move and position trolleys in this space.
- Allow clearance for legs underneath for sitting.
- Avoid fixed cabinetry underneath which projects into the leg space area.

Standing counter height – fixed: There should be 1000 mm measured from floor to finished desktop.

Standing counter height – adjustable: There should be a range of 900 to 1200 mm measured from floor to finished desktop.

Sit/stand counter height: The sit stand range should be 650 to 1250 mm measured from floor to finished desktop.

Sitting counter height – fixed: The fixed height should be 720 mm measured from floor to finished desktop.

Counter hob (on patron side) if fitted should not rise more than 250 mm above height of counter measured from floor to finished counter hob.

Counter depth requirement may vary according to the functions of the counter. The minimum recommendation is 750 mm to accommodate all screen-based equipment, focal distance, required desk top items and for displaying and/or signing documents, placement of delivery items etc however the following must be considered:

- Comfortable reach distances across the counter for the user and customer. Maximum reach distance should not exceed 500 to 600 mm
- Consider incorporating a curved or cut out section in the centre of the desktop.
- Adequate depth to meet security requirements.

Workstations located behind the counter/reception must be have a clear sight line to the counter.

Where there is a regular requirement for the user and patron/student to simultaneously view a monitor screen consider back to back screens. If not possible a flexible monitor arm is required.

Recessing a monitor into the desk surface and covering with glass is not recommended as it involves an awkward neck posture and potential glare.

Duress buttons if required should be installed within comfortable reach (within 150 mm of the front edge of the desk and in the work zone).

2.8.4 **Teaching and Collaborative Learning Spaces, Lecture Theatres**

Teaching and collaborative learning spaces and lecture theatres shall comply with relevant Legislation, Standards and Codes including but not limited to:

- National Construction Code

Collaborative teaching areas should be multipurpose flexible student-centred spaces have a level floor and movable furniture which promote students working together. As such the clearances and space requirements are different from a staff office layout.

Floor plan and layouts shall be designed to maximise eye contact and sight lines between students, staff and visual/teaching aids It should be possible to configure seating to ensure that users do not have to adopt awkward or twisted postures

A solid stable writing surface shall be provided for each student, such as chairs with tablets or tables which may be mobile, flip tables, configurable to many layouts

Minimum clearances between tables should be 1700 mm to allow chair and pedestrian movement

Casual stools to be used at tables, benches, bars or counters should be stable and tip resistant and have a height range of 660 to 760 mm.

Lecture Theatres

Lecture theatres are generally single function didactic teaching spaces on a tiered or sloping floor surface with fixed seating that has provision for a laptop/notepad, generally without windows and well equipped for audio-visual communication. Multiple electronic screens may be provided to facilitate viewing from all seats

Spatial allowance of 1.1 to 1.3 square metres per student should be allowed for new theatres.

Aisles should be provided on either side of the theatre with a minimum width 1200 mm to enable prime viewing area at front for seats.

Tiered row spacings, distances of seats from aisles must comply to the National Construction Code.

Tiers or step riser should be a minimum of 150 mm. Adequate visual cues on tread and landing shall be provided to aid visibility in dimmed lighting conditions.

A clear view of the lecturer, screens, boards, presentation materials and equipment should be possible from each seated position of the theatre without the user having to adopt awkward postures.

Access to writing boards should be easy without interference from projection screens.

Refer to Design Standard, Section 8, *Fire Protection and Detection Services* for further requirements regarding escape routes, exit doors and exit and emergency lighting.

2.9 **DESIGN CHANGE AUTHORISATION**

The requirements and standards noted in the University Design Standards are to be complied with. Any request for change to the requirements of the Design standards must be made on the Modification Request Form.

No design work is to proceed on the basis of the proposed modification until the modification request has been approved in writing.

SECTION 3 – SUSTAINABLE DESIGN

CONTENTS

3.1	GENERAL	2
3.2	SUSTAINABILITY REQUIREMENTS BASED ON PROJECT TYPE.....	2
3.3	INFORMED DESIGN.....	2
	3.3.1 Value-for-money	2
	3.3.2 Climate Change Resilience	6
	3.3.3 Combatting Modern Slavery	6
	3.3.4 Operational Waste Management and Logistics Plan.....	6
	3.3.5 Energy Analysis	7
	3.3.6 Water Analysis	7
3.4	MINIMISE CONSTRUCTION IMPACTS.....	8
	3.4.1 Environmental Management Plan	8
	3.4.2 Construction and Demolition Waste Management Plan and Reporting	8
3.5	QUALITY ASSURANCE	8
	3.5.1 Certification	8
	3.5.2 Considerations for “or equivalent”	9
3.6	DESIGNING FOR OPERATIONAL OUTCOMES.....	9
	3.6.1 Campus as a Living Lab	9
	3.6.2 Energy & Emissions.....	9
	3.6.3 Water.....	10
	3.6.4 Waste & Recycling.....	10
	3.6.5 Transport.....	12
	3.6.6 Biodiversity	12
	3.6.7 Sustainable Buildings & Communities	15

3.1 GENERAL

Sustainability is fundamental to the University of Melbourne. The University's 5-year plan, Growing Esteem, states:

We will know we have been successful in our aspirations if, by 2020, the University of Melbourne is...recognised as a leader in embedding sustainability in all aspects of the University's operations, teaching and learning, research and engagement.

This vision is enacted by the University's Sustainability Charter, Sustainability Plan and a range of operational plans, as well as these Design Standards. The purpose of this chapter of the Design Standards is to help project teams understand what applies to their project and how to comply.

3.2 SUSTAINABILITY REQUIREMENTS BASED ON PROJECT TYPE

Table 1 summarises how the University's sustainability requirements typically apply to projects based on type and scale. Each requirement is explained further in the remainder of this chapter. There may be instances where a particular project should comply with greater or fewer requirements – in these instances project consultants should consult the University Project Manager.

3.3 INFORMED DESIGN

3.3.1 Value-for-money

Life cycle cost analysis

Project consultants are required to undertake life cycle cost analysis (LCCA) to help the University appropriately balance the upfront and ongoing costs of its built and natural assets (refer to Table 2). The purpose of this analysis is to understand the *relative* life-cycle costs between available options, not to predict the *actual* life-cycle costs.

The University recognises that detailed LCCA may not be appropriate for smaller projects, in these projects, advice should be sought from relevant University staff – including client users, the Infrastructure Services team and the University's Project Manager – regarding how the design can decrease operating costs.

Life Cycle Cost Analysis must be undertaken in accordance with a relevant and recognised standard, such as:

- AS/NZS 4536:1999 Life cycle costing—An application guide
- [BSRIA Guide 67/2016 Life Cycle Costing](#)
- [RICS 2016 Life Cycle Costing](#)

Advice must be sought from the University regarding key inputs, such as discount rates and operating costs for similar buildings / building components within the University's portfolio. The analysis must include sensitivity testing of key input assumptions.

Where the design options under consideration are not significantly different (e.g. the maintenance requirements of both options are the same), this may be omitted from the LCCA analysis.

Table 1 – Sustainability requirements for different types of projects

Requirements (refer to subsequent sections in this chapter for details)		New building or “major” refurbishment	Minor refurbishment of an existing building	External works
Informed design	Value for money	✓	For projects that impact HVAC, building fabric and/or flooring	✓
	Climate change resilience	✓	For projects that have high-value contents or are critical to business continuity (e.g. research freezers, data centres, cultural collections etc)	✓
	Combatting Modern Slavery	✓		✓
	Environmental Management Plan	✓	✓	✓
	Operational Waste Management Plan	✓	✓	
	Energy analysis	✓		
	Water analysis	✓		For projects that have irrigation requirements
Minimise construction impacts	Environmental Management Plan	✓	✓	✓
	Construction and Demolition Waste Management Plan	✓	✓	✓

Requirements (refer to subsequent sections in this chapter for details)		New building or “major ¹ ” refurbishment	Minor refurbishment of an existing building	External works
Quality assurance	Certification (e.g. Green Star)	✓		
Outcomes	Sustainability Plan – Campus as a living lab	✓		✓
	Sustainability Plan – Energy & emissions	✓	Where projects impact the building’s energy consumption (e.g. lighting, HVAC, building fabric, large electrical equipment, potential for onsite generation)	
	Sustainability Plan – Water	✓	✓	For projects that have irrigation requirements
	Sustainability Plan - Waste & Recycling	✓	✓	✓
	Sustainability Plan – Transport	✓	✓	✓
	Sustainability Plan – Biodiversity	✓		✓
	Sustainability Plan – Sustainable Buildings & Communities	✓		✓

Note: Definitions of project type

1. Refurbishment of an existing building – ‘Major’: where more than 50% of a building is refurbished over a period of 3 years or less

Table 2 – Life cycle cost analysis

Building components	Key operating costs to consider	Life Cycling Cost Analysis approach to be used	
		Minor refurbishment	Major refurbishment / new building
Façade and HVAC	<p>Façade cleaning costs (including different access methods)</p> <p>Energy costs related to façade and HVAC options</p> <p>Maintenance costs associated with HVAC options</p>	Based on experience, with input from relevant University Staff	<p>Life Cycle Cost Analysis, informed by:</p> <p>Whole project energy model</p> <p>Estimated façade cleaning requirements and costs</p> <p>Estimated maintenance requirements and costs</p>
Flooring	<p>Cleaning costs (e.g. carpet vs vinyl vs resilient surface treatments)</p>	Based on experience, with input from relevant University Staff	<p>Life cycle cost Analysis, informed by:</p> <p>Likely cleaning frequency of floor finish options</p> <p>Likely replacement frequency of floor finish options</p> <p>Cleaning and replacement costs</p>
Onsite generation (particularly PV)	<p>Energy costs related to onsite PV (or other) generation</p> <p>Maintenance costs associated with onsite generation</p>	Based on experience, with input from relevant University Staff	<p>Life cycle cost Analysis, informed by:</p> <p>Estimated generation potential</p> <p>Estimated energy cost reduction and other potential income (e.g. renewable energy certificates)</p> <p>Estimated maintenance costs</p>

Value-for-money tracking

Projects must track and report on the value-for-money of the sustainability initiatives proposed. One approach successfully used on the University's Arts West project is described in the Value-for-money tracking Guidance Note located in the Associated Documents section of the Design Standards web page.

On projects targeting a Green Star rating, this activity should contribute to the project achieving the financial transparency Innovation Challenge credit (see Section 3.6.7).

Regardless of the approach used, estimates of value should be holistic and consider desirable outcomes for the University in terms of strategic goals and operational

needs. The following value categories are recommended as a starting point for individual projects:

- *Supports project objectives / business case* - The initiatives proposed support project objectives or business case drivers. Typically, this applies to initiatives that impact user experience, teaching, research, and / or engagement outcomes.
- *Reduces lifecycle costs* - The initiatives proposed are expected to have lower life cycle costs than other options.
- *Enhances University reputation / fulfils commitments* - The proposed initiatives enhance the University's reputation with key internal and external stakeholders (typically something that is engaging and that key stakeholders care about) or fulfils a University commitment / plan / strategy / policy.
- *Increases confidence* - The proposed initiatives typically reduce risks for the project or University, increasing confidence that sustainability (and other) outcomes will be successfully delivered.

3.3.2 Climate change resilience

Major refurbishment and new building projects, refurbishments that are business critical or involving high-value contents, and significant external works must:

- Undertake a project specific climate change resilience review in accordance with AS 5334:2013 *Climate Change Adaptation for Settlements and Infrastructure*
- Identify significant climate change risks and develop appropriate mitigation measures
- Identify opportunities for the project to increase the ability of future building occupants and asset managers to cope with the impacts of climate change (referred to in climate change risk management literature as “adaptive capacity”).
- Ensure any residual risk is clearly documented and provided to the University project manager in a format compatible with the University's Enterprise Risk Management System.

The resilience review should be undertaken by an appropriately experienced external consultant.

Further information is provided in the Climate Resilience Guidance Note located in the Associated Documents section of the Design Standards web page.

3.3.3 Combatting Modern Slavery

For major refurbishments and new buildings, a desktop study into modern slavery risks for constructions projects is to be undertaken, highlighting labour practices, raw and manufactured materials (virgin and reused) and countries of origin that are at higher risk of having modern slavery in their supply chain and possible mitigation strategies for the project team to consider.

Smaller projects and fit-outs are encouraged to consult the outcomes of desktop studies previously undertaken on other projects or by the University.

Further information, including key outcomes of previous desktop studies, is provided in the Modern Slavery Guidance Note located in Associated Documents section of the Design Standards web page.

3.3.4 Operational Waste Management and Logistics Plan

For minor refurbishments of existing buildings:

- Provide space for waste and recycling bins within the fit-out in accordance with University Standards. Refer to 3.6.4 Waste & Recycling for details.
- Where there is a change in use, or expected increase in occupant numbers, consult with the relevant staff in the Sustainability team, Campus Services, to confirm the number of bins required or any other special requirements (e.g. hazardous waste).
- If the refurbishment involves a change in use (e.g. from office to food & beverage, or to a use that involves hazardous materials), a suitably experienced consultant must prepare an Operational Waste Management and Logistics Plan. Otherwise, the waste, recycling and logistics management plan may be produced in consultation with the relevant staff in the Sustainability team, Campus Services, or by a suitably experienced consultant.

For new buildings and major refurbishments of an existing building:

- Develop a project specific operational waste, recycling and logistics management plan that identifies the material streams into / out of the building, the type and number of bins required, storage requirements, the need for loading docks or other material handling equipment. The plan must co-ordinate with any applicable precinct or campus plans or strategies regarding waste, recycling and materials handling.
- The plan must be prepared by a suitably experienced consultant and approved by the University Project Manager.
- Provide the facilities and space for bins and material handling equipment recommended by the waste, recycling and logistics management plan. Refer to 3.6.4 Waste & Recycling for details of University standard bins.

3.3.5 Energy analysis

Applicable projects, as defined by Section 3.2 Sustainability Requirements Based on Project Type, are to produce a whole-project energy model to inform the design, provide input to life cycle cost analysis, and provide estimates for the University in terms of future energy consumption (relevant to energy costs and carbon neutral commitments).

To make the energy models more useful for forward projections for the University, they are required to include scenarios of key variables (e.g. high / low occupancy, longer hours of use, hotter / colder than average etc) as determined by the University's Project Manager.

For further information refer to Section 7 - Electrical Services and Section 9 - Mechanical Services

3.3.6 Water analysis

Applicable projects, as defined by Section 3.2 Sustainability requirements based on project type, are to produce a whole-project water model to inform the design and provide estimates for the University in terms of future potable and non-potable water consumption.

It is expected that projects targeting Green Star ratings (i.e. major refurbishments and new buildings at a minimum) will use the Green Star Water Calculator, with supplementary calculations if needed. Projects not targeting Green Star ratings may still use the Green Star Water Calculator, or their own calculations.

The water model is expected to consider the following end-uses:

- Fixtures and fittings
- Whitegoods
- Heat rejection
- Wash-down
- Fire system testing
- Irrigation
- Any other significant consumer of water

For further information refer to Section 6 – Hydraulic Services

3.4 MINIMISE CONSTRUCTION IMPACTS

3.4.1 Environmental Management Plan

All projects must prepare and implement an environmental management plan to a recognised and applicable standard or guideline to manage environmental performance, conditions and impacts arising from demolition, excavation and construction.

Examples of recognised standards / guidelines include:

- City of Melbourne
www.melbourne.vic.gov.au/SiteCollectionDocuments/construction-management-guidelines.pdf
- City of Wyndham
<http://wcc.prod.pnx.com.au/sites/default/files/2016-06/Melbourne%20Water%20Site%20Environmental%20Management%20Plan%20Template.pdf>
- NSW
www.procurepoint.nsw.gov.au/documents/construction-guidelines-environmental-management-systems-ed3.docx

Head contractors for major refurbishments and all new buildings must prepare and implement an environmental management plan in accordance with Green Star Design & As-built Credit 7.0 and 7.1.

3.4.2 Construction and Demolition Waste Management Plan and Reporting

New build and major refurbishment projects should target Green Star credit 22 (refer Section 3.6.7).

All projects must consider opportunities to reuse and recover furniture and equipment in consultation with the Infrastructure Services Reuse Centre. Consideration should also be given to opportunities for recovery of building materials (for example cleaned bricks or timber panelling) for future use on University building projects.

3.5 QUALITY ASSURANCE

3.5.1 Certification

In accordance with the University's Sustainability Plan 2017 – 2020:

- All new buildings and major refurbishments that will be completed before 2020 must achieve a minimum five-star Green Star 'Design and As Built' rating (or equivalent)
- All new buildings and major refurbishments that will be completed in 2020 and after must achieve a minimum six-star Green Star 'Design and As Built' rating (or equivalent).

The University is not currently mandating Passive House certification on projects and maintains a watching brief regarding risks and opportunities associated with the design outcomes (e.g. very low levels of air leakage) and attributes (e.g. imported air-tight window and door hardware) that are often associated with Passive House buildings.

Further information is provided in the Air Tightness guidance note located in Associated Documents section of the Design Standards web page.

3.5.2 Considerations for “equivalent” certification

The Sustainability Plan requires new buildings to achieve certified Green Star ratings “or equivalent”. The following must be considered when determining equivalency:

- Certification applies to design and construction
- The impact areas covered are at least as broad as those in Green Star.
- The level of certification is equivalent to the required level in Green Star (E.g. 5 Star Green Star = Australian Excellence; 6 Star Green Star = World Leadership)
- The certification involves an independent assessment by a person, company or entity not involved in the project. Any associated costs, such as certification or assessor fees, will need to be determined by the project team, factored into the project cost plan and assigned to the most appropriate entity (typically the University or head contractor).

3.6 DESIGNING FOR OPERATIONAL OUTCOMES

The following sub-sections highlight key operational outcomes for the University as identified by *Sustainability Plan 2017 – 2020*.

3.6.1 Campus as a living lab

New and major refurbishment projects, and significant external works, must identify, report on the feasibility of, and, where appropriate, implement opportunities for the campus to be a living lab.

Further information is provided in the Campus as a Living Lab fact sheet located in Associated Documents section of the Design Standards web page.

3.6.2 Energy & emissions

Minimum plant and equipment efficiencies are stated in relevant sections of these design standards, including:

- Section 9: Mechanical Services

In addition to the nominated plant and equipment efficiencies, projects eligible for a Green Star rating (or equivalent) must achieve the number of points nominated for Green Star Credit 15E.1 in Section 3.6.7.

Internal lighting shall have an installed light power density at least 30% below the maximum requirements of Section J 2016 (Refer Section 7.9.1).

External lighting shall have a light source efficacy at least 30% better than the minimum required by Section J 2016 (Refer Section 7.9.1).

Light pollution from external lighting shall be controlled in accordance with Credit 27 of Green Star Design & As-built v1.2. (Refer Section 3.6.7).

For new building and major refurbishments, project teams must report to the University on opportunities for onsite generation. Consult the University's Project Manager for information regarding University-wide programmes for onsite generation. Note that the Life Cycle Cost Analysis section requires a feasibility study into PV (refer Section 3.3.1).

For major and other refurbishments, project teams must report to the University on building envelope opportunities to improve energy consumption, thermal comfort, daylight, glare and views. Any envelope modification must take a balanced approach and not improve one outcome to the unacceptable detriment of others.

Photovoltaic installations

If a building subject to a major refurbishment has good solar resource potential, the building's electrical switchboard and distribution, roof and location of any roof-mounted plant should be designed to readily allow future PV installation. Refer to Electrical Services Section 7.12 for more information on PV systems.

Apply 'zero emissions-ready' approach to all campus development projects

A priority action in the Sustainability Plan is to "Develop new buildings on campus with 'zero emissions-ready' approach", which refers to buildings avoiding gas combustion. Projects that currently (in the case of refurbishments) or may (in the case of new) use gas (e.g. for heating or hot water) must consider and report on the feasibility of "no gas" to the University's Project Manager.

3.6.3 Water

It is required that:

- All fixtures and fittings are appropriately water efficient (e.g. generally within 1 star of the best available WELS rating)
- Landscape/irrigation design is water sensitive. Refer to Section 15: Grounds and Landscaping

The use of captured rainwater is encouraged for cooling towers, irrigation and toilet flushing.

Projects should include water storage tanks within the precinct and connect to the section of recycled water purple pipe (where available), adjacent to the project site. Infrastructure to monitor all harvested water usage should be considered in consultation with Infrastructure Services and the University's Project Manager (Refer Section 6.2.13).

3.6.4 Waste & Recycling

Design consultants must make appropriate space allowance for all waste collection and disposal requirements and clearly identify these locations in the project documentation.

Waste Collection

Open office areas – The University will supply and place these bins. The approved bins are Method brand red top landfill and amber top recycling bins.



Kitchens – The University’s preference is to use the Method brand red top landfill and amber top recycling bins (supplied and placed by the University). In instances where open space for these bins cannot be provided, under bench collection bins are acceptable. The preferred type is Halo Jumbo 42 hinged panel waste bin. In these instances, the builder is to supply and install the bins.

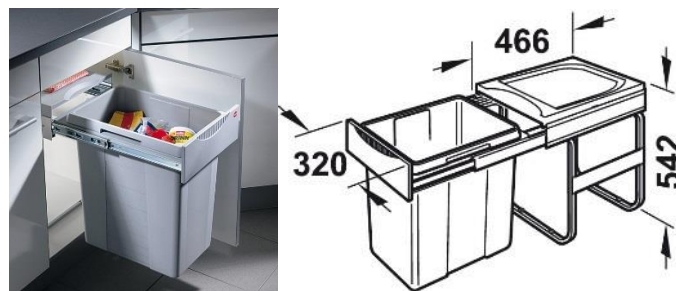

Foyers etc – The University will supply and locate these bins. The approved bins are EcoElegance brand, stainless steel dual bins.



Bathrooms – The University will supply and place these bins. The approved bins are Method brand grey top paper towel bins.



External bins – Refer to Section 15 of the Design Standards, Grounds and Landscaping for details of the bin type and installation details. These bins are to be supplied and installed by the builder or landscaping contractor.

Waste Disposal

The University typically uses 120, 240 and 660 litre Wheelie bins or waste skips for waste disposal. The design consultant is to ensure that adequate space (including vehicle access) is provided for the waste disposal facility identified in the Waste Plan (refer Section 3.3.4). Appropriate water supply, drainage, hardstand and visual barriers are to be provided.

3.6.5 Transport

Cyclist facilities

Cyclist facilities should be provided, unless:

- It can be demonstrated that the precinct or campus already has sufficient cyclist facilities, or
- The University is developing the required cyclist facilities as part of a separate project elsewhere, or
- A precinct or campus cycling strategy does not require them.

Cyclist facilities includes bike racks, lockers and showers, as described in Green Star Credit 17B.4.

The proportion of cyclist facilities should be based on University data as a starting point where it is available, rather than default to industry benchmarks (e.g. Green Star). For example, data for the Parkville main campus indicates that cyclists can be in the range of 11 – 18% of people on campus.

3.6.6 Biodiversity

To achieve the University's sustainability aspirations, the biodiversity present on campuses must not only be preserved but enhanced and assisted to thrive under changing climate conditions and human urban and agricultural development. The following table details the actions required by the design team to meet the University's Biodiversity Management Plan.

Table 3 – Requirements for compliance with Biodiversity Management Plan

No.	Biodiversity Management Plan requirement	Application to relevant projects
1	All relevant global, national, bioregional and local policies and action plans be taken into account and complied with as far as is possible when managing on-campus biodiversity.	Comply with the action.
2	Biodiversity values will be considered as part of the scheduled update to the University's Climate Change Adaptation Plans.	Temperature vulnerability of trees and other plantings to be considered as part of species selection.
3	The character and location of each campus will be taken into account when dealing with species that may be characterised as valuable heritage at one campus and unwanted species at another.	Comply with the action.
4	A policy of "no Net Loss" (with promotion of the better outcome of "Net gain") will be adhered to across all campuses.	Comply with the action.
5	Assess and quantify the landscape context for each campus and use this information to develop Action Research Partnerships that identify and test critical habitat, resources and improvements that can enhance biodiversity outcomes for each site.	The University's Biodiversity Co-ordinator and Grounds Manager to provide the project team with relevant information regarding landscape context.
6	The Biodiversity Coordinator will work with relevant indigenous individuals and organisations to obtain local knowledge when gathering information for campus biodiversity plans.	Consider relevance / significance of landscape to indigenous people as part of review of existing landscape elements and design of new elements
7	Clearly define and promulgate the practices of "Campus as a Living Lab" and "Active Research Partnership"	Project leadership to facilitate living lab opportunities. Biodiversity Co-ordinator to assist in relation to biodiversity opportunities.
8	Harness in-house research expertise and utilise it for the benefit of campus biodiversity	Comply with the action.
9	Urban Forestry Guidelines for the Parkville and Southbank campuses of the University are developed (in conjunction with the City of Melbourne Urban Forest Plan.)	Biodiversity Co-ordinator to share the guidelines (draft or finalised) with the project team as part of consultation required for Action 10.

No.	Biodiversity Management Plan requirement	Application to relevant projects
10	Mechanisms are set in place to ensure that the Biodiversity Coordinator is included in consultations when planning occurs for any significant campus changes.	Project leadership to include the University's Biodiversity Co-ordinator in relevant meetings, workshops and decision-making
11	All available, relevant on-campus biodiversity data is collected, collated and integrated into a publicly accessible database, e.g. the Atlas of Living Australia.	All new plantings are documented and integrated into the University of Melbourne planted species database

3.6.7 Sustainable Buildings & Communities

Projects required to achieve Green Star ratings must do so in a way that is aligned with University policies, strategies, plans and values. As noted in Section 3.3.1, projects are required to identify how sustainability initiatives on a project can provide value to the University and track this over the course of a project.

Table 4 recommends Green Star credits for projects based on experience of what typically provides best value for the University. The credits nominated are not necessarily mandatory (noting that some credits are referred to elsewhere in this and other chapters of the Design Standards), but any deviation from those listed must be justified and approved by relevant the University's Project Manager.

Table 4 – Recommended Green Star Design & As-built credits

CATEGORY / CREDIT	CODE	CREDIT CRITERIA	POINTS AVAILABLE	POINTS RECOMMENDED	Typically supports / enhances project objectives	Reduces lifecycle costs	Enhances University reputation / fulfils responsibilities	Increases confidence	Policy / strategy alignment
Management			14						
Green Star Accredited Professional	1.0	Accredited Professional	1	1				Yes	
Commissioning and Tuning	2.0	Environmental Performance Targets	-	complies			Yes	Yes	Sustainability Plan - Energy, Water
	2.1	Services and Maintainability Review	1	1		Yes		Yes	Design Standards Section 9 – Mechanical services
	2.2	Building Commissioning	1	1		Yes		Yes	Design Standards Section 9 – Mechanical services Design Standards Section 10 – BAS
	2.3	Building Systems Tuning	1	1		Yes		Yes	Design Standards Section 9 –

CATEGORY / CREDIT	CODE	CREDIT CRITERIA	POINTS AVAILABLE	POINTS RECOMMENDED	Typically supports / enhances project objectives	Reduces lifecycle costs	Enhances University reputation / fulfils responsibilities	Increases confidence	Policy / strategy alignment
									Mechanical services
	2.4	Independent Commissioning Agent	1	1		Yes		Yes	Design Standards Section 9 – Mechanical services
Adaptation and Resilience	3.1	Implementation of a Climate Adaptation Plan	2	2			Yes	Yes	Climate Resilience Framework Design Standards Section 9 – Mechanical services Design Standards Section 6 – Hydraulic Services
Building Information	4.1	Building Information	1	1		Yes		Yes	Design Standards Section 6 – Hydraulic Services Design Standards Section 9 – Mechanical services

CATEGORY / CREDIT	CODE	CREDIT CRITERIA	POINTS AVAILABLE	POINTS RECOMMENDED	Typically supports / enhances project objectives	Reduces lifecycle costs	Enhances University reputation / fulfils responsibilities	Increases confidence	Policy / strategy alignment
Commitment to Performance	5.1	Environmental Building Performance	1	1			Yes		Sustainability Plan - Energy, Water, Waste
	5.2	End of Life Waste Performance	1	1			Yes		Sustainability Plan - Waste
Metering and Monitoring	6.0	Metering	-	complies		Yes		Yes	Design Standards Section 6 – Hydraulic Services
	6.1	Monitoring Systems	1	1		Yes		Yes	Design Standards Section 10 – BAS
Responsible Building Practices	7.0	Environmental Management Plan	-	complies				Yes	
	7.1	Formalised Environmental Management System	1	1				Yes	
	7.2	High Quality Staff Support	1				Yes	Yes	

CATEGORY / CREDIT	CODE	CREDIT CRITERIA	POINTS AVAILABLE	POINTS RECOMMENDED	Typically supports / enhances project objectives	Reduces lifecycle costs	Enhances University reputation / fulfils responsibilities	Increases confidence	Policy / strategy alignment
Operational Waste	8A	Performance Pathway - Specialist Plan	1	1		Yes	Yes	Yes	Sustainability Plan - Waste
	8B	Prescriptive Pathway - Facilities	-						
Total			14	13					

Indoor Environment Quality			17					
Indoor Air Quality	9.1	Ventilation System Attributes	1					
	9.2	Provision of Outdoor Air	2					
	9.3	Exhaust or Elimination of Pollutants	1					
Acoustic Comfort	10.1	Internal Noise Levels	1	1	Yes			Design Standards Section 12 - Acoustics

CATEGORY / CREDIT	CODE	CREDIT CRITERIA	POINTS AVAILABLE	POINTS RECOMMENDED	Typically supports / enhances project objectives	Reduces lifecycle costs	Enhances University reputation / fulfils responsibilities	Increases confidence	Policy / strategy alignment
	10.2	Reverberation	1						
	10.3	Acoustic Separation	1						
Lighting Comfort	11.0	Minimum Lighting Comfort	-	complies					
	11.1	General Illuminance and Glare Reduction	1	1	Yes	Yes			
	11.2	Surface Illuminance	1						
	11.3	Localised Lighting Control	1						
Visual Comfort	12.0	Glare Reduction	-	complies					
	12.1	Daylight	2						
	12.2	Views	1						
Indoor Pollutants	13.1	Paints, Adhesives, Sealants and Carpets	1	1	Yes		Yes		

CATEGORY / CREDIT	CODE	CREDIT CRITERIA	POINTS AVAILABLE	POINTS RECOMMENDED	Typically supports / enhances project objectives	Reduces lifecycle costs	Enhances University reputation / fulfils responsibilities	Increases confidence	Policy / strategy alignment
	13.2	Engineered Wood Products	1	1	Yes		Yes		
Thermal Comfort	14.1	Thermal Comfort	1	1	Yes		Yes		Design Standards Section 9 – Mechanical services
	14.2	Advanced Thermal Comfort	1						
Total			17	5					
Energy			22						
Greenhouse Gas Emissions	15E.0	Conditional Requirement: Reference Building Pathway	-	complies					

CATEGORY / CREDIT	CODE	CREDIT CRITERIA	POINTS AVAILABLE	POINTS RECOMMENDED	Typically supports / enhances project objectives	Reduces lifecycle costs	Enhances University reputation / fulfils responsibilities	Increases confidence	Policy / strategy alignment
	15E.1	Comparison to a Reference Building Pathway	20	12 ¹		Yes	Yes		Sustainability Plan - Energy
Peak Electricity Demand Reduction	16A	Prescriptive Pathway - On-site Energy Generation	-						
	16B	Performance Pathway - Reference Building	2	1		Yes			
Total			22	13					
Transport			10						
Sustainable Transport	17A.1	Performance Pathway	10		Yes		Yes		Sustainable Transport Plan

¹ Note that 6 points for Credit 15E.1 are required as a minimum in Green Star Design & As-built v1.2 for a 6 Star rating. This, combined with the University's commitment to zero emissions from electricity, and the fact that Credit 15E.1 allows zero-carbon purchased electricity to double credit points achieved through building design, lead to a default position that 12 points should be targeted as a minimum.

CATEGORY / CREDIT	CODE	CREDIT CRITERIA	POINTS AVAILABLE	POINTS RECOMMENDED	Typically supports / enhances project objectives	Reduces lifecycle costs	Enhances University reputation / fulfils responsibilities	Increases confidence	Policy / strategy alignment
	17B.1	Access by Public Transport	0						
	17B.2	Reduced Car Parking Provision	0						
	17B.3	Low Emission Vehicle Infrastructure	0						
	17B.4	Active Transport Facilities	0						
	17B.5	Walkable Neighbourhoods	0						
Total			10	0					
Water			12						
Potable Water	18A.1	Potable Water - Performance Pathway	12	6	Yes	Yes	Yes		Sustainability Plan – Water Design Standards Section 9 – Mechanical services

CATEGORY / CREDIT	CODE	CREDIT CRITERIA	POINTS AVAILABLE	POINTS RECOMMENDED	Typically supports / enhances project objectives	Reduces lifecycle costs	Enhances University reputation / fulfils responsibilities	Increases confidence	Policy / strategy alignment
	18B.1	Sanitary Fixture Efficiency	0						
	18B.2	Rainwater Reuse	0						
	18B.3	Heat Rejection	0						
	18B.4	Landscape Irrigation	0						
	18B.5	Fire System Test Water	0						
Total			12	6					
Materials			14						
Life Cycle Impacts	19A.1	Comparative Life Cycle Assessment	6			Yes	Yes	Yes	
	19A.2	Additional Life Cycle Impact Reporting	4			Yes	Yes	Yes	
	19B.1	Concrete	3						
	19B.2	Steel	1						

CATEGORY / CREDIT	CODE	CREDIT CRITERIA	POINTS AVAILABLE	POINTS RECOMMENDED	Typically supports / enhances project objectives	Reduces lifecycle costs	Enhances University reputation / fulfils responsibilities	Increases confidence	Policy / strategy alignment
	19B.3	Building Reuse	4						
	19B.4	Structural Timber	4						
Responsible Building Materials	20.1	Structural and Reinforcing Steel	1				Yes		
	20.2	Timber Products	1				Yes		
	20.3	Permanent Formwork, Pipes, Flooring, Blinds and Cables	1				Yes		
Sustainable Products	21.1	Product Transparency and Sustainability	3						
Construction and Demolition Waste	22A	Fixed Benchmark	0						
	22B	Percentage Benchmark	1	1			Yes		Sustainability Plan - Waste
Total			12	1					

CATEGORY / CREDIT	CODE	CREDIT CRITERIA	POINTS AVAILABLE	POINTS RECOMMENDED	Typically supports / enhances project objectives	Reduces lifecycle costs	Enhances University reputation / fulfils responsibilities	Increases confidence	Policy / strategy alignment
Land Use & Ecology			6						
Ecological Value	23.0	Endangered, Threatened or Vulnerable Species	-	complies			Yes		Biodiversity Management Plan Design Standards Section 15 – Grounds and Landscaping
	23.1	Ecological Value	3		Yes		Yes		Biodiversity Management Plan Design Standards Section 15 – Grounds and Landscaping
Sustainable Sites	24.0	Conditional Requirement	-	complies					
	24.1	Reuse of Land	1	1			Yes		
	24.2	Contamination and Hazardous Materials	1						

CATEGORY / CREDIT	CODE	CREDIT CRITERIA	POINTS AVAILABLE	POINTS RECOMMENDED	Typically supports / enhances project objectives	Reduces lifecycle costs	Enhances University reputation / fulfils responsibilities	Increases confidence	Policy / strategy alignment
Heat Island Effect	25.0	Heat Island Effect Reduction	1						
Total			6	1					

Emissions			5						
Stormwater	26.1	Stormwater Peak Discharge	1				Yes	Yes	Climate Resilience Framework Sustainability Plan – Water Design Standards Section 6 – Hydraulic Services
	26.2	Stormwater Pollution Targets	1				Yes	Yes	Climate Resilience Framework Sustainability Plan – Water Design Standards Section 6 – Hydraulic Services

CATEGORY / CREDIT	CODE	CREDIT CRITERIA	POINTS AVAILABLE	POINTS RECOMMENDED	Typically supports / enhances project objectives	Reduces lifecycle costs	Enhances University reputation / fulfils responsibilities	Increases confidence	Policy / strategy alignment
Light Pollution	27.0	Light Pollution to Neighbouring Bodies	-	complies			Yes		Biodiversity Management Plan
	27.1	Light Pollution to Night Sky	1	1			Yes		Biodiversity Management Plan
Microbial Control	28.0	Legionella Impacts from Cooling Systems	1						
Refrigerant Impacts	29.0	Refrigerants Impacts	1						
Total			5	1					
Innovation			10						
Innovative Technology or Process	30A	Innovative Technology or Process	10						

CATEGORY / CREDIT	CODE	CREDIT CRITERIA	POINTS AVAILABLE	POINTS RECOMMENDED	Typically supports / enhances project objectives	Reduces lifecycle costs	Enhances University reputation / fulfils responsibilities	Increases confidence	Policy / strategy alignment
Market Transformation	30B	Market Transformation							
Improving on Green Star Benchmarks	30C	Improving on Green Star Benchmarks							
Innovation Challenge	30D	Innovation Challenge: Financial transparency		1				Yes	Sustainability Plan - Sustainable Buildings and Communities
Innovation Challenge	30D	Innovation Challenge: Reconciliation Action Plan		1			Yes		RAP3

CATEGORY / CREDIT	CODE	CREDIT CRITERIA	POINTS AVAILABLE	POINTS RECOMMENDED	Typically supports / enhances project objectives	Reduces lifecycle costs	Enhances University reputation / fulfils responsibilities	Increases confidence	Policy / strategy alignment
Innovation Challenge	30D	Innovation Challenge: Marketing Excellence	10	1 ²			Yes	Yes	Sustainability Plan - Sustainable Buildings and Communities
Innovation Challenge	30D	Innovation Challenge: Occupant Engagement (BOSSA survey)		1	Yes		Yes	Yes	Sustainability Plan - Sustainable Buildings and Communities
Global Sustainability	30E	Global Sustainability							
Total			10	40.0					
				40.0					
			TOTALS AVAILABLE	4.0					
			CORE POINTS	100	44.0				

² A copy of the Marketing Excellence credit submitted as part of the Parkville Green Star Communities rating can be obtained from Property & Sustainability, which may assist projects to understand how the credit criteria can be interpreted for the University.
 Design Standards
 Section 3: Sustainable Design – 8 Jan 2019

CATEGORY / CREDIT	CODE	CREDIT CRITERIA	POINTS AVAILABLE	POINTS RECOMMENDED	Typically supports / enhances project objectives	Reduces lifecycle costs	Enhances University reputation / fulfils responsibilities	Increases confidence	Policy / strategy alignment
		CATEGORY PERCENTAGE SCORE		34.0					
		INNOVATION POINTS	10	4.0					
		TOTAL SCORE TARGETED		38.0					

SECTION 4: STRUCTURAL & CIVIL CONTENTS

4.1	INTRODUCTION	2
4.2	STRUCTURAL DESIGN CRITERIA	2
4.2.1	Floor Loadings	2
4.2.2	Floor Vibrations/Dynamics	2
4.2.3	Durability	3
4.2.4	Design for Future Flexibility	3
4.2.5	Masonry	3
4.2.5.1	Brick Growth	3
4.2.5.2	Walls and Expansion Joints	3
4.2.6	Roofing	3
4.2.6.1	Roofs	3
4.2.6.2	Guttering & Downpipes	4
4.3	CIVIL	4
4.3.1	External Stormwater Drainage	4
4.3.2	Vehicular Pavement	4
4.3.2.1	Flexible (Asphalt) Pavements	4
4.3.2.2	Rigid (Concrete Pavements)	4
4.4	CONSTRUCTION NOISE & VIBRATION	5
4.4.1	Noise	5
4.4.2	Vibration	5
4.4.3	Management & Mitigation Measures	7
4.5	UNDERGROUND INFRASTRUCTURE	7
4.5.1	Standards & Regulations	8
4.5.2	Investigation & Design	8
4.5.3	Construction	9
4.5.4	Commissioning & Acceptance Testing	9
4.5.6	Certification of Completed Work	9
4.6	DESIGN CHANGE AUTHORISATION	9

4.1 INTRODUCTION

All structural design is to meet the requirements of this section of the University's Design Standards, all relevant Australian Standards and the Building Code of Australia (BCA).

At Concept Design stage, the structural consultant is to document and agree the structural design criteria with the University's Project Manager and the project architect. The design criteria should cover the following scope:

- Dead and Live Loads (loading diagrams may be required)
- Wind Loading;
- Seismic Design Criteria;
- Deflection Limits;
- Floor Vibration Limits;
- Durability;
- Fire Resistance; and
- Design for Future Flexibility.

4.2 STRUCTURAL DESIGN CRITERIA

4.2.1 Floor Loadings

Floor loadings shall be designed to the relevant Australian Standard, or the following table, whichever is the greater:

(a) Minimum loading for all non-residential floors:

– general live load	4 kPa
– demountable partitions	0.5 kPa
(b) Compactus areas	10 kPa
(c) Communication rooms	5 kPa
(d) Air handling, refrigeration and boiler plant rooms	7 kPa
(e) Open roof-top plant platforms	2.5 kPa or 5.0 kPa

In addition to the live load, a minimum superimposed dead load allowance of 0.3 kPa for ceiling and services shall be provided.

Some heavily loaded areas, such as archives and library shelving, or areas with heavy equipment will require computations to establish the floor loadings.

4.2.2 Floor Vibrations/Dynamics

All floors are to be designed to an appropriate footfall vibration criterion, to be determined by the structural engineer. As a minimum, no floor is to be designed with a response factor of less than 8. A response factor of 4 is to be considered for quiet offices.

Particular consideration is required in relation to laboratory and other specialist uses, in particular when used for balancing, microscopy and other sensitive laboratory equipment. The structural engineer shall determine the required footfall vibration limits based on the building's functional needs and future flexibility. At a minimum, laboratories intended for undergraduate teaching are to comply with ASHRAE Curve F (response factor =1.0) at the worst point on the floor. The performance of laboratories intended for research is to be agreed with the University Project Manager based on the equipment intended to be installed. At a minimum, 50% of the floor area of research laboratories is to comply with ASHRAE Curve VcA, (Response factor = 0.5) with the balance complying with Curve F.

The structural engineer is to provide the University with a plot of the floor performance so that sensitive equipment can be installed in the higher performing areas. Vibrations from plant and other equipment is to be addressed by isolation at source.

4.2.3 Durability

The design life for all structural elements is 50 years. Maintenance costs are to be minimised throughout. The structural materials and finishes selection is to ensure that no maintenance is required in the first 25 years of the building's life

4.2.4 Design for Future Flexibility

University buildings may be refurbished several times for differing purposes over their lifetime. Hence, the structure is to be designed with flexibility for future change in use in mind. A regular column grid is encouraged, and minimal internal structural walls. No floor is to be designed for less than the minimum load nominated above.

The structural engineer is to establish whether any specific allowances are to be made for future expansion either vertically or horizontally in conjunction with the University Project Manager.

4.2.5 Masonry

4.2.5.1 Brick Growth

- Masonry shall be designed to prevent the problems associated with brick growth.

4.2.5.2 Walls and Expansion Joints

- As the cost of building will be influenced by the structural system and external wall cladding, the method of facade proposed shall be discussed with the University's Project Manager at an early stage of the development of the design.
- Care shall be taken to ensure that there are sufficient control joints in all wall materials to avoid cracking due to shrinkage and expansion of the material, movement of the supporting structures under wind and other effects or unequal settlement.
- Any movement joints in the structure behind are to be carried through the cladding.
- Adequate weathering shall be provided for all copings, sills and at heads to openings.

4.2.6 Roofing

4.2.6.1 Roofs

- Care shall be taken in the design and specification of roofs to avoid rain penetration in strong winds.
- Pitched roofs shall be used in preference to flat roof systems. The buildings users may, however, require some useable roof area for experimental or other purposes.
- All roof spaces shall have permanent, fixed, adequate access; be provided with catwalks and be sufficiently lit to enable the roof space to be traversed without danger 24 hours a day.
- The chemical reaction of aluminium in contact with other metals in an exposed situation shall be avoided.
- The method of proposed roof and facade access shall be discussed with the University's Project Manager at an early stage of the development of the design. Consideration must be given to installation of anchor points/static lines etc on the roof for harness attachments.

4.2.6.2 Guttering & Downpipes

Refer to section 5 of the Design Standards: Building Fabric, for guttering and downpipe requirements.

4.3 CIVIL

4.3.1 External Stormwater Drainage

The storm water network external to the building footprint shall be designed in accordance with AS 3500.3. The network shall be designed to convey, without surcharge, the 5% AEP (20-year ARI) plus 20% increase factor to allow for the potential effects of climate change. Appropriate overland flow paths shall be provided to prevent inundation of buildings in extreme events or in cases where the network becomes blocked.

Surface storm water shall be collected via various inlets within the surface such as grated pits, grated trench drains, side-entry pits and channels and conveyed within the underground piped drainage network to the existing trunk drainage systems or to the legal point of discharge as nominated by the responsible council.

Where the responsible council imposes restrictions on storm water discharge rates from the development, detention storage shall be provided to the satisfaction and approval of the council.

Grated pits and trench drains within hard pavements must be flush with their surroundings and 'heel safe' rated in pedestrian areas. All pit covers must be of strength class suitable to their location and must consider all loading scenarios including emergency vehicles or heavy cleaning equipment.

Water Sensitive Urban Design (WSUD) elements will be considered where possible in coordination with the Landscape Design and will typically include elements such as permeable pavement, bioretention cells and systems capable of capturing gross pollutants and sediment.

4.3.2 Vehicular Pavement

4.3.2.1 Flexible (Asphalt) Pavements

Design of light and medium duty pavements (design traffic in range of 10^3 to 10^5 ESA's) shall be designed in accordance with ['Austroads Technical Report AP-T36/06-Pavement Design for Light Traffic'](#).

Heavy duty pavements with design traffic $> 10^5$ ESA's pavement designs should be carried out in accordance with Austroads publication ['Guide to Pavement Technology Part 2: Pavement Structural Design'](#) (2018).

Appropriate geotechnical investigations shall be carried out to determine performance criteria of the underlying subgrade material.

Subsoil drainage systems shall be provided where necessary to protect the pavement subgrade formation.

4.3.2.2 Rigid (Concrete Pavements)

Rigid pavements may be designed in accordance with the Cement and Concrete Association of Australia, (Third Edition Oct 2009), ['Guide to Industrial Floors and Pavements - Design, Construction and Specification'](#).

4.4 CONSTRUCTION NOISE & VIBRATION

This section provides construction noise and vibration targets for occupied areas of the University. Where construction is undertaken on University land and requested by the University Project Manager, a Construction Noise and Vibration Management Plan is required to be submitted by the appointed contractor detailing:

- Construction equipment used;
- location/distances of construction equipment;
- timing and duration of construction works;
- predicted noise and vibration impacts; and
- mitigation and management methods to manage the noise and vibration impacts.

Wherever possible the noise and vibration impacts shall be reduced to comply with the targets set out in the following sections. Where the targets cannot be achieved, mitigation and management methods are to be applied to reduce the impacts as much as possible.

4.4.1 Noise

The targets for internal noise levels due to construction noise are shown in the table below. Where the target is exceeded, then management actions would need to be implemented.

Sensitive Area	Internal Construction Noise Level Target, dB(A) $L_{eq,15min}$
Teaching spaces	45
Lecture theatres	40
Open office spaces	45
Private offices	40
Meeting rooms / conference rooms	40
Computer laboratories (non-teaching)	50
Other laboratories (non-teaching)	50
Libraries	
General areas	50
Reading areas	45
Common rooms	45
Public spaces	50
Cafes	50

4.4.2 Vibration

The targets for vibration due to construction works are based upon the NSW document [Assessing Vibration: A Technical Guideline](#) (the NSW Guideline) and reproduced in the table below. As per the NSW Guideline, management actions should be implemented if the Vibration Dose Values (VDVs) are exceeded, specifically:

- Management actions should be implemented where the Preferred levels are exceeded, and levels up to the Maximum levels are permissible as long as reasonable and feasible actions have been taken; and

- Where the Maximum levels are exceeded, negotiation must be undertaken with the University's Project Manager.

Table 1 Construction vibration targets as Vibration Dose Values (VDV)

Location	Preferred VDV	Maximum VDV
	m/s ^{1.75}	m/s ^{1.75}
Particularly sensitive spaces	0.1	0.2
Offices, schools, educational institutions, places of worship	0.4	0.8
Workshops	0.8	1.6

The use of VDVs require the assessment of vibration levels over an extended period, which is not always practical. Therefore, it may be easier for the vibration targets to be converted to a Peak Particle Velocity (PPV) level, which allows for the assessment of vibration based on short-term measurements.

Table 2 presents PPV construction vibration targets based on Annex A of AS 2670.2 and the NSW document [Assessing Vibration: A Technical Guideline](#). Note that the PPV targets in 2 are relatively conservative as they are based on continuous (rather than impulsive) vibration and are based on conservative assumptions with regard to crest factor and orientation of the occupant with respect to the vibration.

Table 2 PPV construction vibration targets

Location	Preferred PPV	Maximum PPV
	mm/s	mm/s
Particularly sensitive spaces (e.g. Alice Hoy Optometry)	0.14	0.28
Offices, schools, educational institutions, places of worship	0.56	1.1
Workshops	1.1	2.2

To assist with the assessment of risk from construction vibration, Table 3 presents typical safe working distances for potential key construction plant that may be expected on site based on prior experience. Note that the distances may need to be increased for areas with vibration-sensitive equipment.

Table 3 Recommended safe working distances for key vibration-intensive plant

Plant	Rating	Typical safe working distance for occupant comfort
		m
Vibratory roller	< 7t	≥ 35
	7t – 12t	≥ 50
	≥ 13t	≥ 75
Rock saw		≥ 35

Plant	Rating	Typical safe working distance for occupant comfort
Bulldozer ripping rock	D8 type	≥ 35
Rock-breaking	Small hammer 300 kg: 5-12t excavator	≥ 20
	Medium hammer 900 kg: 12-18t excavator	≥ 35
	Large hammer 1600 kg: 18-34t excavator	≥ 70
Impact piling	≤ 800mm	≥ 100
Bored piling	≤ 800mm	≥ 20
Jackhammer	Handheld	Avoid contact with structure

Contractors carrying out work on University sites must also ensure construction vibration levels do not cause damage to structures. This generally only becomes a concern at levels well above those which may annoyance to building occupants. Guidance on acceptable vibration levels for preventing damage to structures, including heritage-listed structures, is given by German Standard DIN 4150-3:1999 *Structural Vibration – Part 3: Effects of vibration on structures*.

4.4.3 Management & Mitigation Measures

Appropriate management and mitigation measures will vary from project to project. However, consideration should be given to the following:

- Decanting of spaces that may be significantly affected. This will require discussion with and approval from the University's Project Manager;
- The timing of works and whether potentially annoying works can be undertaken at times when sensitive uses are less sensitive or unoccupied;
- The provision of respite periods to affected sensitive users;
- The use of less noise- and or vibration-intensive plant;
- The installation of temporary mitigation measures to reduce noise levels such as hoarding or glazing upgrades to affected uses;
- The location of noisy activities, including compounds, away from sensitive areas.
- The use of existing shielding features to reduce noise levels;
- Minimising the use of tonal reversing beepers through the use of alternative non-tonal alarms or the design of access routes to remove the need for reversing; and
- The enforcement of good on-site practice to reduce noise levels associated with shouting, swearing, and the use of horns as signalling devices.

4.5 UNDERGROUND INFRASTRUCTURE

This section provides details of minimum requirements for the design and construction of underground infrastructure including interface points with Utility Service Providers (USP's).

The requirements outlined in this section fit between Section 6 of the Design Standards: Hydraulic Services and the connection point to USP owned assets.

4.5.1 Standards & Regulations

All underground infrastructure works shall meet all the requirements of national and local authorities and shall be in accordance with the following in so far as they apply to the work:

- Building Code of Australia and Building Permit conditions;
- SAA National Plumbing and Drainage Code AS 3500;
- AS 3500 Plumbing and Drainage;
- WorkCover for the relevant state (e.g. WorkCover QLD, SA, NSW etc.);
- Worksafe at Federal Level;
- OHS regulations;
- Environment Protection Authority for relevant state;
- EnergySafe Victoria;
- Gas Installation Code SA5601.1;
- Water Services Association of Australia Codes;
 - WSA 03-2011-3.1 Water Supply Code of Australia Melbourne Retail Water Agencies (MRWA) Edition Version 2
 - WSA 02-2014-3.1 Gravity Sewerage Code of Australia Melbourne Retail Water Agencies (MRWA) Edition Version 2
 - WSA 01-2004 Polyethylene Pipeline Code Version 3.1
 - WSA 05-2013 Conduit Inspection Reporting Code of Australia Version 3.1
 - These codes are updated periodically, the latest versions must be used and can be obtained by visiting the Water Services of Australia website <https://www.wsaa.asn.au/shop/category/1>
- AS 1289 Methods of testing soils for engineering purposes;
- AS 1379 Specification and supply of concrete;
- AS 1906 Retroreflective materials and devices for road traffic control purposes;
- AS 2566.1 Structural Design of Buried Flexible Pipe;
- AS 2566.2 Installation of Buried Flexible Pipe;
- AS 2685 Safe Working in Confined Space; and
- AS 4020 Products for use in contact with water intended for human consumption with regard to their effect on the quality of water.

4.5.2 Investigation & Design

- a) Designs are to be undertaken by personnel competent and experienced in the design of underground infrastructure;
- b) The Designer(s) must visit site, identify the location and depth of other UoM and Utility services and locate all property and fire service connections;
- c) The Designer(s) must liaise with all affected utility providers to determine their requirements for interface points, access, maintenance and metering; and
- d) The location of all pits, tanks and pumping stations shall be designed to allow convenient access for operations, maintenance and repairs.

4.5.3 Construction

Prior to commencing construction, the contractor must provide a copy of the following documents to the University's Project Manager for approval;

- i. All contractual documentation outlined in the construction contract (i.e. security, insurances etc)
- ii. Tree Protection Plan
- iii. Traffic Management Plans
- iv. Construction Management Plan
- v. Safety Management Plan including all safe work method statements
- vi. Inspection and Test Plan (ITP)
- vii. Reinstatement and Landscape Plan

4.5.4 Commissioning & Acceptance Testing

- a) A commissioning and test plan must be submitted to the University's Project Manager for approval;
- b) Draft Operating Manuals must be submitted four weeks prior to practical completion. Any training of University personnel must be undertaken prior to practical completion being awarded;
- c) Final Operating Manuals must be submitted within four weeks of practical completion.
- d) As-constructed drawing shall conform to the University's CAD standard requirements (refer to the Design Standards web page);
- e) Any CCTV required by the inspection test plan must be submitted to the University's Project Manager; and
- f) Any guarantees and warranty information must be submitted.

4.5.6 Certification of Completed Work

The contractor shall issue upon practical completion of the works all Utility certifications and any other necessary Certificate(s) of Compliance nominating the works carried out on the project and submit the certificate(s) to the University's Project Manager.

4.6 DESIGN CHANGE AUTHORISATION

All requests for changes to the requirements of the Design Standards must be made on the Modification Request Form. No design work is to proceed on the basis of the proposed modification until the modification request has been approved in writing.

SECTION 5: BUILDING FABRIC CONTENTS

5.1	INTRODUCTION	2
5.2	GENERAL REQUIREMENTS	2
5.2.1	General Building External Fabric	2
5.2.2	Roofing	3
5.2.3	Windows, Glazing and Window Cleaning	5
5.2.4	Doors, Door Hardware and Keying	7
5.2.5	Summary of Door Types, Door Hardware and Keying	12
5.2.6	Internal Walls & Partitions	13
5.2.7	Ceilings	14
5.2.8	Floors	14
5.2.9	Painting	15
5.2.10	Furniture, Fixtures and Fittings	16
5.2.11	Toilet Fixtures & Fittings	17
5.2.12	Design Change Authorisation	18
5.2.13	As Built Information, Warranties and Manuals	18

5.1 INTRODUCTION

This section of the Design Standards provides details of the University's minimum requirements for Building Fabric. The Project consultant is required to produce their own specification incorporating the following information and submit all design and documentation for review prior to tendering or any works commencing on site.

All building development must be consistent with the University's maintenance practices, procedures and requirements. A safety and design methodology must be used.

The materials specified shall reflect low maintenance considerations. All building fabric components shall be readily accessible for maintenance and repair.

5.2 GENERAL REQUIREMENTS

5.2.1 *General Building External Fabric*

- All building works shall fully comply with the Design Standards, but particular attention is to be paid to the Sustainable Design requirements noted in Section 3.
- Refer to Design Standard Section 4, Structural and Civil for additional requirements relating to the design of structural building elements.
- Façade materials shall be durable and easily maintained.
- Anti-graffiti protection shall be applied to ground level external surfaces.
- External walls shall be brick, concrete or full height glazing and be respectful to the local built environment, including heritage requirements;
- Façade staining shall be avoided by careful design and detailing to shed water clear of the building, lower projections and pathways. Parapet capping and window framing shall be designed to ensure façade staining is avoided.
- Windows should be well shaded, provide good views and let in lots of daylight without causing glare discomfort to occupants;
- If the building is not fully air-conditioned, windows should be openable for cross ventilation;
- The chosen façade materials should have thermal resistance to keep excess heat out during summer and insulate effectively in winter. Recommended ratings are R1.5 for walls and R2.5 for ceilings. R ratings for the walls and ceilings are in accordance with Section J of the Building Code of Australia (BCA);
- The consultant team is required to pay particular attention to the Deemed to Satisfy requirement for the use on non-combustible materials on the external walls of Type A and Type B construction. The consultant must not consider the use of combustible external wall insulation materials without the written approval of the University's Project Manager. The University's Project Manager is required to take advice from the University's Insurance Manager.
- Façade systems, shading systems and glazing shall conform to the requirements of the Building Code of Australia (BCA);
- The placing of protruding building services and equipment on building façades and rooftops shall be avoided or shielded from view.

Brickwork

- Brickwork shall be designed to prevent the problems associated with brick growth.
- Provision of adequate control joints in all masonry walls shall be included. Joints shall be thoroughly sealed to prevent water ingress.

Walls and Expansion Joints

- Care shall be taken to ensure that there are sufficient control joints in all wall materials to avoid cracking due to shrinkage and expansion of the material, movement of the supporting structures under wind and other effects or unequal settlement. Any movement joints in the structure behind are to be carried through the cladding.
- Adequate weathering shall be provided for all copings, sills and at heads to openings.

Aluminium Composite and Expanded Polystyrene Panelling

- The use of Aluminium Composite Panelling (ACP) as a façade material is not supported.
- If the design team proposes to use ACP on a building facade, its use shall be subject to approval in writing of the University's insurer.
- In addition, the proposed use of ACP material must be supported by written evidence of compliance with the latest edition of AS 5113 Fire Propagation Testing and Classification of External Walls of Buildings, other relevant Australian Standards, NCC requirements, relevant Ministerial Guidelines and a detailed risk assessment as part of the Safety in Design review.
- Expanded Polystyrene products or other foam plastic insulated external wall material must not be used.

5.2.2 Roofing

- Minimum roof pitches shall be avoided. Roof pitches of less than 3 degrees are not acceptable.
- All roof spaces shall be well ventilated and have adequate, permanent, fixed access provided and be sufficiently lit to enable the roof space to be safely traversed 24 hours a day.
- Roof and roof drainage systems shall be designed to accommodate the storm event detailed in Section 6.2.7 of the Hydraulic Services section of the Design Standards.
- Dissimilar metals are not to be used in roofing installations.
- Light coloured roofing and cladding should be utilised to minimise heat absorption.
- Refer to Design Standards Structural and Civil Section 4 for additional requirements for design of structural elements.
- There shall be close collaboration with the consultant team and the University of Melbourne Project Manager to ensure that roofs comply with the Design Standards and project specific requirements.
- Where appropriate, rainwater collection and storage for reuse should be considered.

Roof Access

- Roof access door/hatches including ladder/stair access shall be secured utilising either electronic access control, or auditable electronic key and lock system (EKA Cyberlock). Refer to Design Standards Section 13, Security for additional requirements.
- Lift access shall be provided where roof top plant space is proposed.
- Access to the roof shall allow for ease of maintenance and replacement of roof mounted plant and equipment.
- Where required for maintenance/cleaning and general access, provide a compliant roof safety system.
- The roof safety system shall include the appropriate combinations of components including horizontal safety cable, anchorage points or other fall restraint devices via proprietary roof walkway and safety systems.

Roof access safety systems are to comply with relevant Australian Standards. Prior of the issuing of the certificate of practical completion, the building contractor is to appoint an independent certifier to certify compliance of the roof access safety system with the relevant Australia standards. The University's Project Manager will provide the names of the approved certifier.

Roof Membranes

Shall be three-layer membrane systems comprising of

- Floating separation backed membrane
- 3mm middle sheet fibre glass
- 4.5mm reinforced UV stable mineral chip cap sheet
- Allow 10% extra for laps and wastage
- All torch applied
- Allow for vents each 50m²

Installation shall incorporate recommended surface preparation ensuring that the surface shall be free from sealant, loose aggregate and other contaminates.

Where no cove is present on stairs, cove shall be installed prior to membrane application

Guttering and Downpipes

- Internal gutter design shall be considered only as a last option but if included shall clearly demonstrate the inclusion of controlled overflow to prevent leaf blockage. Necessary joints shall be first class quality in design and workmanship, with an inspection opening provided for cleaning. For maintenance purposes a minimum width of 450mm and a minimum depth of 150mm are suggested. Internal downpipes shall generally be oversized, with no sharp twists and turns;
- Shoes of downpipes shall have a 100mm screwed IO access point above the shoe, when connected directly to a stormwater drain. Downpipe shoes over pits shall discharge 80mm above a grating of the pit. All rainwater heads shall be accessible.
- All rain heads at the top of downpipes shall have provision for overflows.
- Full and appropriate calculations shall be undertaken to establish roof drainage requirements and the capacity of the design to properly discharge rainwater and to incorporate fail-safe design practice.
- Where practicable, the design shall avoid box/internal gutters and internal downpipes. If specified these shall:
 - Be appropriately detailed to eliminate the risk of blockage and flooding
 - Include visible overflows
 - Overflows are to discharge conspicuously in the event of blockage.
 - Overflow design to avoid staining of external facades
 - Ensure that the overflow is not directed to main downpipe
 - Be fully accessible for cleaning.
- Box gutters and downpipes and other inaccessible components such as valley gutters shall be constructed from either stainless steel, copper, or zinc. Dissimilar metals should not make contact with each other.
- All gutters shall be fixed independently of roof decking and over-flashings with adequate expansions joints.
- Regardless of design calculations gutters shall have a minimum depth of 90mm with a minimum of 25mm freeboard.

- All box gutter sumps shall be fitted with removable galvanised mesh type leaf guards across the full area.
- Sumps are to be a minimum of 450mm and depth of 150mm.
- Eaves gutters are to be run into large, external downpipes of minimum 150mm diameter through rain water heads.
- Downpipes shall be detailed to discharge over collector pits at ground level, each incorporating a leaf trap and grate at ground/surface level. The grate level is to be at least 75mm above any garden mulch. For cleaning purposes clear space of a minimum of 80mm is to be allowed between the bottom of downpipes and the grate.
- Internal downpipes within ducts shall be sanitary plumbing class UPVC or HDPE and shall be sized in accordance with Section 6.2.7 of the Hydraulic Services section of the Design Standards but on no occasions less than 100mm diameter. When PVC is used it should be in accordance with [The Best Practice Guidelines for PVC in the Built Environment](#) as per the Green Building Council of Australia.
- Downpipes shall not be cast into concrete columns but shall be enclosed in a suitable duct with inspection openings.
- To avoid damage, downpipes shall be located in protected areas away from heavy pedestrian or vehicular traffic. Where downpipes in vehicular areas are unavoidable, permanent bump protection is required.

5.2.3 **Windows, Glazing and Window Cleaning**

When designing glazed openings, the benefits of natural lighting and ventilation shall be weighed against solar and thermal loads. The design shall demonstrate adequate consideration of the following:

- Careful attention shall be paid to the problem of noise in high winds, water proofing, thermal and structural movement, the impact on energy consumption and security.
- Sun control techniques (including internal and external shading devices and control of glare).
- Maximised use of natural light.
- Designed in accordance with the BCA and the required thermal resistance required for external glazing.
- Generally, provision shall be made for shading of glazed areas from early October to early March.

Windows

- Windows shall be operable, unless inappropriate due to environmental conditioning, security and/or health and safety considerations.
- All operable windows are to be designed to satisfy the University's safety and OHS requirements. In particular, the size of openings must eliminate the risk of access through the window.
- Design of operable windows shall eliminate any risk of climbing or falling. Implement the advice described in the [ABCB Advisory Note 2013-1 Protection of Openable Windows](#) (August 2016 revision) with consideration that the University is a child friendly workplace.
- The location of operable windows above or adjacent to trafficable areas should be avoided.
- Windows in high traffic and vandal-prone areas shall be impact resistant or otherwise protected.

- Fitted screens shall protect operable windows from the ingress of insects and should be easily accessible for removal and cleaning.
- Window design shall incorporate robust and reinforced commercial framing suites hardware and finishes selected for durability and environmental considerations.
- Enhanced solutions such as increased glass thickness, double glazing and tinting shall be incorporated to reduce noise, sun glare, and heat gain and loss as appropriate.
- Where specified, sashes shall be either sliding or double hung.
- All external windows shall incorporate glare control blinds unless approved. Refer to Section 5.2.10 Blinds for additional requirements.
- Where skylights, light shelves, atria or clerestories have been incorporated, adequate and appropriate maintenance plans and facilities are to be included.
- Aluminium windows shall be etched prior to anodising. The required thickness of anodising shall be specified in microns and approved by the University's Project Manager.
- Powder coated window frames may also be used where the colour has been approved.
- Prior to practical completion training and induction relevant to the operation of any motorised or manual facade access systems, is to be provided to nominated staff and contractors.

Glazing

- Glass fitted to windows and doors shall comply with the relevant Australian Standards.
- Glazing shall be specified based on environmental and acoustic considerations.
- A risk management approach for glazing of high activity and other risk exposures (e.g. Childcare Centre's and sporting facilities) shall be carried out in accordance with AS1288.
- Consideration shall be given to the Worksafe [Victoria 'Use of Glass in Workplaces Providing Early Childhood Education and Care Services'](#) safety alert issued in August 2017.
- Laminated glass is the preferred minimum requirement for installations. Float glass shall not be used.
- Toughened laminated glass is to be used in all high risk areas as deemed appropriate after carrying out a risk assessment.

Glazing Decals

- Decals to full height glazing in teaching spaces shall be provided to meet minimum statutory requirements. Obscuring the view into teaching spaces with film or decal is not acceptable.
- Decals or film to offices are to ensure that some transparency is maintained to all enclosed spaces. Opaque film is not acceptable to any area.
- Print on clear film or laser cut decals are acceptable.
- Refer to the University's Signage Guidelines for additional signage requirements. These are located on the University's Design Standards web page.

Window Cleaning

- Ease of and safe access for the cleaning (internal & external) and maintenance of windows is a very important requirement in the design and shall be addressed during the design process.
- Buildings that are three or more floors in height should include a fixed building access system for maintenance and cleaning of external facades;
- Where a Building Maintenance Unit (BMU) is to be used for external window cleaning appropriate docking or fixing devices are to be provided on the exterior of the building.

5.2.4 Doors, Door Hardware and Keying

- Doors are to be sized to suit the maximum widths required for the purpose of the space. Consideration is to be given to peak demand times in teaching spaces, Australian Standards (AS1428) and DDA access requirements.
- All doors to teaching and learning spaces are to have clear vision panels to allow visual connection and safe opening.
- Timber doors are to be of solid core construction, hollow core doors are not acceptable. Doorways and openings are to have dimensions that allow equipment to be removed or reinstalled. The method of changing/maintaining the largest item of plant is to be indicated
- All doors shall be furnished with restrainers, door stops, door closers etc. to prevent impact damage to adjacent surfaces.
- Door stops shall not be located in close proximity to the hinge. Where floor mounted door stops are likely to create a trip hazard when fixed in the normal location beneath the door handle, a door stay is to be used instead, fixed to the head of the door.
- Any door fixings to lightweight metal shall be provided with backing plates for support.
- Typically, doors shall be designed with lever style handles.
- Oversize doors are to be detailed to include sufficient hinges and hardware to ensure ease of operation and durability is achieved.
- In areas prone to vandalism or high student usage, handles and mechanism shall be sufficiently robust to withstand vandalism, abuse and the effects of frequent use.
- Door frames are to be aluminium or steel and to be fitted with a double rebate to allow for future alterations.
- Doors shall be located adjacent to walls to provide a definite door stop and thus avoid hinge stress damage due to over extension by the action of wind or students.
- Doors are to be robust and suitable for the intended purpose of the space. High traffic areas are to have automatic sliding doors.
- Doors shall have the equivalent acoustic and/or fire performance of the wall in which they are built.
- Highly customised doors and door frames are to be avoided. Non – approved door hardware is not to be used.
- Double acting doors are to be detailed to prevent binding between the leaves. If not double acting, double doors shall have rebated stiles, or equivalent metal stop to inactive leaf.
- Access and security controls are to be integrated into doors and frames where required. Refer to Design Standard Section13, Security for additional requirements.

External Doors:

- The number of external doors to buildings is to be kept to a minimum and have door furniture that enables the doors to be self-locking.
- External, open out, swing doors with 3570/3770 series lock or equal and approved equivalent locks shall have a 'Blocker" fitted to prevent tampering with locks.
- Glass doors shall be clearly marked, such that they are visible to all users of the building, with push/pull or sliding signs and include an intermediate safety bar.
- Where exposed to the weather anodised aluminium door and frame with laminated safety glass is preferred. As a minimum, doors to have 200mm mid-rail for Lockwood 3500 series lock or equal and approved equivalent;
- Doors to be hung using threshold pivot set with Dorma RTS85, or equal and approved equivalent, transom mounted concealed overhead closers;
- Doors in public areas shall have glazing panels or glazed door sidelights;
- Fire-rated doors to be metal sheeted mineral core with pressed metal frame and hardware all to be factory fitted and assembled. If necessary, a viewing panel shall be installed.
- Doors are to comply with AS 1905.1-2005;
- Hold open devices to be fitted in high traffic areas;
- Non-fire-rated external doors, are to be metal sheeted mineral core with pressed metal frame, factory fitted assembly.
- Doors shall be sufficiently recessed into foyers to protect from prevailing wind pressure and rain or shall be weather protected with canopies.
- Airlocks shall be sized to permit the safe closing of doors, allowing each set to close before the next is opened.
- Timber doors shall be solid core faced with painted waterproof 4mm, A-Bond ply and pre-primed solid top, bottom and edge strips.
- Aluminium doors shall be constructed:
 - From a commercial grade section and have a solid bottom panel
 - With pivot type hinges complete with floor springs and concealed head closers.
- Weatherproof seals shall be fitted to the bottoms and edges of all external doors and to the meeting stiles of double doors.
- Doorways shall be designed with no step at the threshold. Where at risk to weather ingress, weather seals and small aperture drainage grates shall be incorporated.
- External swing back of house doors to be metal clad to both sides with full perimeter channel fixed with countersunk steel screws. If door is to be unpainted then it must be stainless steel with stainless steel fixings.
- Power to automatic sliding doors at building entrance(s) shall be key switch operated and should have key override switch compliant with Design Standards Section 13, Security requirements.
- Where security access control systems are to be installed an approved electronic lock and mounting position is to be provided. Refer Design Standard Section 13 *Security* for additional requirements.
- Where applicable, power to automatic sliding doors is to be interfaced in a fail-safe manner, to be activated in an open position in case of a fire alarm signal from the

Fire Indicator Panel. Refer Section. Refer Design Standard Section 8, Fire Protection and Detection Services for additional requirements.

- Doors in main circulation areas and high traffic areas are to be automatic sliding doors.

Smoke and Fire Doors:

- Fire doors shall incorporate a vision panel providing a minimum of 600mm (H) x 100mm (W) and 1000mm (AFFL).
- External fire doors to be faced on both sides with metal sheeted adhesive, fixed with fabricated perimeter channel of the same material. Countersunk stainless-steel screw fixed through edge.
- Refer to Design Standard Section 8, Fire Protection and Detection Services for additional requirements.

Internal Doors:

- May be anodised aluminium as for external.
- Timber doors shall be solid-core with a minimum thickness of 42mm. Finish to suit. i.e. clear finish, prime coated hardboard for gloss paint, plastic laminate to wet areas;
- All doors to have timber edge strips to top and two sides. If required viewing panels should be installed;
- Internal fire-rated doors as for external with finish to suit installation;
- Framed timber doors to be minimum thickness of 42mm with top rail and stiles 120mm wide;
- Middle and bottom rail to be 190mm wide;
- Aluminium doors not to be narrow style but full size to accommodate 3570/3770 series primary lock i.e. Lockwood.
- All two-way doors shall include vision panels; glass doors shall be marked appropriately;
- Vision panels to be a minimum of 600mm (H) x 100mm (W) and 1000mm (AFFL).

Door Frames:

- All external door frames are to be anodised aluminium or pressed steel. Pressed steel to be 1.6mm thick and zinc coated, rebated, fully welded and reinforced and back plated for 3no. 100x75mm hinges, lock strike and door closer. 2no. rubber buffers are to be fitted to the lock side. All to be shop primed and installed to manufacturers recommendations;
- Pressed steel is preferred for internal door frames. When in timber they are to be 32mm minimum thickness kiln dried hardwood for the full width of the wall.

Door Locks and Hardware Schedule:

- For refurbishments projects, the existing door hardware and cylinders remain the property of the University of Melbourne and, prior to demolition they must be removed and delivered to the Security office.
- For refreshment project, furniture and hardware selection shall ensure a consistent approach to all door locks and hardware selection and eliminate the use of non – approved items.
- All locks shall be keyed in accordance with the University's Master Keying system
- A complete lock and hardware schedule with floor plans (including master keying) shall be prepared by the Principal Consultant in conjunction with the University's

Project Manager, the University Security Operations Co-ordinator and the user department.

- The final room numbering system must be established before the lock schedule and floor plans are finalised.
- All automatic door controls, control locks to lifts and roller grilles shall be as per the University's Master Key System.
- Correct strike plates and strike boxes shall be specified for all frames.
- Where possible, directory and notice boards shall be keyed alike.
- All door furniture shall be specified to have sealed finishes that will not corrode or tarnish.
- For all double doors, the inactive leaf is to be specified to be fitted with top and bottom flush bolts to the leading edge. Where door exceed 2100mm (H) extended flush bolts are to be specified.
- All fixing and locking hardware for industrial doors are to be specified to be fitted to the inside of the door, where practicable.
- Roller shutter type doors are to be specified to be secured internally at both ends of the bottom rail with appropriate key systems.
- Where the building entry/exit doors, plant room doors, fire escape doors and other selected internal and external doors are to be provided with electric door strikes, metal mortar guard protection boxes are to be provided as a component of the door frames, with pre-drilled crop outs provided for future strike plates as part of the manufactured door frames, compatible to receive the electronic door latch. Similarly, the doors are pre-prepared to receive the non-strike component of the door hardware.
- Dependent upon the final locking configuration and the hardware selected for access control, there may be a requirement for a cylinder and mortice deadlock for separate physical locking and additional hardware if required for an electronic access control system.
- Each copy of a key (including original keys) shall be stamped with a copy number.
- The relevant electrical supply authority will provide special lock cylinders for high tension electrical substations where applicable.

All external and internal fire hose/hose reel cabinets shall be fitted with D handles and roller catches only with 90 or 180 degrees hold-open arms and chains. Doors to cabinets are painted and sign written to comply with the latest relevant Australian Standard, in consultation with the University of Melbourne Project Manager.

Door Hardware Specification

All hardware is to be Lockwood brand, and have a satin chrome finish

Door Furniture:

Lockwood 1800 Series square end furniture with 70 Series lever handle.

Locks:

- All locks shall be Lockwood 3572 or 3772 Series, Satin chrome finished and installed at 1000mm above finished floor level. No locks are to be installed in the bottom rail of doors. The inside handle shall be free at all times.

Cylinders:

All cylinders shall be Lockwood 570 cylinders. All new cylinders shall be keyed to the University Master Key System.

Push plates and handles

Shall be made of stainless steel material.

Door closers:

Door closers can be selected from the following approved products:

- Dorma TS 73 for inward opening doors.
- Dorma TS 83 for outward opening doors.
- Dorma TS 92 and TS 93 are approved for use in public areas only.

The project specification is to include a requirement that all doors are adjusted to meet DDA force limit requirements prior to practical completion.

Kick plates:

- Provide 200mm x 0.9mm satin stainless steel, aluminium or vinyl kick plates that are fit for purpose to the full width of the door in areas such as teaching and office spaces, bathroom facilities or back of house.
- For doors in high impact areas, (e.g. areas where trolleys are used) research facilities or laboratories kick plates to 1000mm (H) shall be installed to the full width of the door, be durable and easily cleaned. Stainless steel is the preferred material for these applications.

Toilets:

- Efc0 EF5551.HOI SSS Partition set, or equal and approved equivalent.

Panic bolts:

- Dalco 1791 or Lockwood 791, or equal and approved equivalent.

Lockable bolts:

- Where a lockable bolt is specified an ADI-5004 shall be used. At the bottom of the door, a lockable bolt no shorter than 300 mm shall be used. At the top of the door bolts should be no shorter than 500mm and be a panic bolt or lockable bolt if required. Bolts should be easily operable by a person of average height.

Blocker plates:

- Where a blocker plate is specified, an ADI or other University approved blocker plate shall be installed.

Hinges

- Fit 3 No. 100x 76mm stainless steel heavy duty hinges to each leaf for doors less than 2040mm tall. For doors greater than 2040mm in height additional hinges will be required at the top of the door.
- Fixed pin to external doors.

Quick-fix hinges are not to be used.

Door seals

- "Raven" type to suit application, or approved equivalent.
- Door seals shall be provided to external doors to comply with the BCA.

External Key Over-Ride Keys Switch

Where key over-ride switches are required, Lock It Well "Auto Series" shall be used, keyed to the University's external master key system. The installer shall obtain cylinders from the University prior to installation of the key switches. Keys for testing shall be provided by the University.

Internal Key Over-Ride Keys Switch

Where key over-ride switches are required, Lock It Well “Auto Series” shall be used, keyed to the University’s external master key system. The installer shall obtain cylinders from the University prior to installation of the key switches. Keys for testing shall be provided by the University.

Lock Schedule:

- For clarity all locks are specified right hand.
- Part numbers do not include master keyed cylinders which shall be supplied by the University.
- All external and internal fire hose cabinets and fire hose shall be fitted with ‘D’ handles and roller catch only.
- Locking for Fire Panels and Early Warning Intercom Systems shall be keyed to CL003 locks.

5.2.5 Summary of Door Types, Door Hardware and Keying

LOCATION	LOCK TYPE	EXTERNAL	INTERNAL
Main Entry	Lockwood 3572SC/3772SC NOCYL	Lockwood 1801/70 SC, Opened by key at all times except when in hold back mode by key from inside. Handle is always rigid.	Lockwood 1901/70 SC Opened by handle at all times. Key operates hold back function. <i>Hold Back</i> (If required) Latch bolt held back when latch depressed and key rotated 360°
Exit – Fire Door	Lockwood 3572SC/ 3772SC	Lockwood 1805/70 SC, Handle is always rigid.	Lockwood 1905/70 SC, Opened by handle at all times.
Exit – Via Stair Well	Lockwood 3572SC/3772SC NOCYL.	Lockwood 1801/70 SC. Opened by key at all times. Opened by handle except when handle is made inoperative by key from inside.	Lockwood 1901/70 SC. Opened by handle at all times. Key locks or unlocks outside handle.
Academic Offices General Staff Offices Conference Rooms	Lockwood 3572SC/3772SC NOCYL.	Lockwood 1801/70 SC. Opened by key at all times. Opened by handle except when handle is made inoperative by turn knob from inside.	Lockwood 1901/70 SC. Opened by handle at all times. Turn knob locks or unlocks outside handle.

LOCATION	LOCK TYPE	EXTERNAL	INTERNAL
Lecture Theatres Seminar Rooms Laboratories	Lockwood 3572SC/3772SC NOCYL.	Lockwood 1801/70 SC. Opened by handle except when handle is made inoperative by key from outside. Key locks or unlocks outside handle.	Lockwood 1905/70 SC. Opened by handle at all times.
Plant Rooms Main Electrical Switchboards Roofs Lift Motor Rooms Service Tunnels	3572SC/3772SC NOCYL.	Lockwood 1801/70 SC. Opened by key. Handle is always rigid.	Lockwood 1905/70 SC. Opened by handle at all times.
Service Panels Cupboards	Lockwood 002-1L1SC NOCYL.	Lockwood Opened by key at all times except when in hold back mode by lever from inside.	Lockwood Opened by handle at all times.
Lecterns AV Cupboards Drawers	Lockwood 693ASC NOCYL, or equal and approved equivalent.	Opened by key at all times.	
Over-ride Key Switch	Lock-it-well Auto Series Key Switch	See Section 13: Security	See Section 13: Security

Keys

- Services location areas (e.g. plant rooms, roof areas, service tunnels, electrical switchboard rooms and lift motor rooms) shall be respectively keyed alike according to type. Each type shall be coded to the University's Master Key System.
- Keys will be provided to the end user by the University.

Ordering and Installation

- The University shall specify keying for all lock cylinders to be fitted.

Practical Completion

- The Consultant, Contractor and the University Project Manager shall check the function and operation of all doors, locks and keys prior to practical completion.
- At the completion of the installation of fire rated doors and frames, a Certificate of Compliance and Log Book in accordance with AS 1905 is to be submitted to the University's Project Manager.

5.2.6 Internal Walls & Partitions

Internal walls shall be lined with 13mm plasterboard.

Internal walls surrounding meeting rooms and offices where minimum noise penetration is required, provision for either 50mm or 75mm polyester batts shall be incorporated into the wall. Boral 'Sound Stop' 13mm plasterboard, or approved equivalent may be used.

In areas of high foot traffic where stud walls are used, Villaboard or high impact plasterboard is to be installed to a height not less than 1200mm.

Walls are to be durable construction with a hard wearing, easily cleaned finish.

- Villaboard or equivalent is to be used in wet areas.
- Corner protection provided to high impact external wall corners.
- Construction is to be suitable for accepting secure fixture of joinery items such as benches, TV screens, shelves (accounting for heavy book loadings), noticeboards, whiteboards, etc. additional noggins are to be included where required.
- Horizontal (dust collecting) surfaces are to be minimised.
- Glazing partition framing to be proprietary commercial aluminium sections suitable for the intended purpose.
- Frames are to have a powder coated or anodised finish.

Skirting

- MDF materials are not to be used for skirting.
- Vinyl or timber skirting to be used where applicable.

5.2.7 Ceilings

- Ceilings shall be designed to ensure safe access to all ceiling services and lighting from within the space. Special consideration shall be given to accessing services in stairwells, and workstation areas safely with minimal disruption to business operations.
- Internal ceiling mounted equipment shall be provided through accessible ceiling tiles or hatches. Equipment located in trafficable ceiling spaces shall have stair access.
- All internal ceilings are to be of the 'Independent Grid' style, using standard size tiles as found throughout the University.
- Ceilings shall be highly durable, and easy to clean.
- Ceiling heights shall be a minimum of 2.4m
- If fixed ceilings are required for specific areas, written approval must be obtained from the University of Melbourne Project Manager. Any internal fixed ceiling shall be of 10mm plasterboard.
- Ceiling access panels are to be located and sized to facilitate easy access, removal or repair of any equipment located above the access panels.
- Ceiling access panels are to be Trafalgar - Access metal flush panel with a cam lock.

5.2.8 Floors

General

- All floor penetrations and associated service pipes are to be documented and to be fully sealed with flexible material to control water penetration between levels, fire separation between compartments and act as a vermin barrier.
- Suspended floors, which are required to support plant or equipment that will induce vibrations, are to be assessed by a suitably qualified and experienced specialist.

- New floors are to be assessed by a suitably qualified and experienced specialist to establish the risk of footfall vibrations.
- Change rooms, cleaner's facilities, kitchens, plant rooms and lift motor rooms shall incorporate grated floor wastes.

Floor coverings

- Refer to Design Standard Section 1, Planning and Architecture for additional requirements.
- Heavy duty and hard wearing modular carpet tile is the preferred floor covering for general offices, teaching spaces and seminar rooms. Interface flor 500mm x 500mm is the University approved carpet tile.
- Broadloom carpet floor finishes are not to be used. If there are circumstances which require the use of broadloom carpet, it must be approved by the University Project Manager. If approved for use, carpet shall not be of a direct stick variety to avoid future delamination issues.
- All floor coverings and floor underlay materials shall be compliant with regards to fire rating as appropriate for the respective area and acoustic performance.
- Floor covering selection shall be fit for purpose for the respective area.
- Vinyl flooring with coved edging to be used in all wet areas and laboratories.
- Where approved for use, vinyl and ceramic floor tiles shall provide the required slip resistance for the intended purpose.

5.2.9 Painting

- For information regarding the Colour Schedule refer to Design Standard Section 1, Planning and Architecture for additional requirements
- Where possible all paints should be water-based acrylic, of a wash and wear type that have a low odour content and a low VOC content.
- Minimum coating requirement shall comprise of 1x sealer coat, 2x undercoats and 1x topcoat. Any additional manufacturer's product sheets/specifications must also be complied with.
- All paint products shall be durable and easily cleanable. Where appropriate the selection of paint should consider mould protection.
- For external applications anti-graffiti protection is to be provided to ground level surfaces
- For internal walls and partitions (except bathrooms, kitchens, change rooms and wet areas), a low sheen paint finish is preferred.
- For kitchens, bathrooms, change rooms and other wet areas, a high performance flat finish is preferred.
- For ceilings, a non-reflective, flat acrylic paint finish is preferred
- Other specialist applications may require specific paint finishes that are fit for purpose.
- At practical completion a schedule is to be provided of the paint supplier and colours for all painted surfaces.

5.2.10 Furniture, Fixtures and Fittings

General

Information on the design of teaching spaces, in particular lecture theatres, can be found in:

- Design Standard Section 1, Planning and Architecture
- Design Standard Section 2, Occupational Health and Safety

Lecture Theatre Seating

- Seating material shall be durable, stain resistant and scotch guard protected. Seating spares are to be readily available and locally sourced.
- Seating style and design is to be consistent with other lecture theatre seating throughout the University.
- Tabloids are to be of robust construction.
- Seat coverings are to be easily removable for cleaning and repair.
- Plastic moulded lecture theatre seating is not acceptable.
- A minimum of 5% spares are to be provided as part of project works.
- Refer to Design Standards Section 1, Planning and Architecture for additional requirements.

Wall Fixments and Shelving

- All shelving must be robust, stable and well secured. Shelf height shall not exceed 2400mm. All shelving exceeding 1800mm must be fixed to a wall.
- Shelving should be designed so books can be stored one deep.
- There should be no sharp edges or corners on shelving or wall fixments. Timber or laminate finishes are preferable.
- There should be a safe means of accessing shelves above shoulder height.
- All shelving must be labelled with maximum load limit signs.
- Refer to Design Standard Section 1, Planning and Architecture and Section 2, Occupational Health and Safety for additional requirements.

Blinds

Depending on the design requirements and window orientations, the following window furnishings may be used:

- Slimline or micro Venetians;
- Holland blinds, including chain driven roller blinds or approved equivalent;
- Block out blind systems;
- Sheer blinds (anti-glare / see through blinds);
- Tinted or laminated coatings on authorisation of the University of Melbourne Project Manager.

All window furnishing specifications are to comply with the following criteria:

- Internal blinds are to control glare and radiant heat; however, they should not be used as a substitute for adequate external solar control devices.
- Blinds shall be easily adjustable and complete with guide rails and associated fixings.

- Block-out and sheer blinds shall incorporate stain protection, anti-microbial properties and anti-bacterial properties. They shall meet all NCC requirements regarding fire hazard etc. properties.
- Installation of blinds shall allow for ease of removal and replacement of all parts. Blinds are not to be fixed to plaster board. All fixings are to be secured into wood or masonry.
- Furniture layouts shall be designed to ensure that the safe and efficient operation of blinds is not compromised.
- All external windows shall have blinds installed, concealed within pelmets or other building elements where possible so that when open they do not obstruct the view to outside.
- Blind fabrics in areas requiring black-out capacity shall be block-out type. Fabrics to external window shall be glare control types where block out is not required.
- Protection buffers are to be installed when floor to ceiling blinds are used.
- Motorised blinds and controllers shall incorporate appropriate electrical and thermal overload protections and 'time-out' functionality to shut down the motor after a nominated period of time.
- Motorised blinds shall incorporate wireless operational/control technology to eliminate multiple cabling requirements and enable easy integration with any proposed AV type modifications.
- Motors shall have a minimum guarantee period of five years. They shall be easily programmable and reconfigurable, without the need for rewiring
- Curtains and drapes may be considered in special applications only, the University's Project Manager approval of any curtain applications and specification is required.
- Window film maybe applied to certain windows to improve solar installation. The selected film must be colour stable, scratch resistant, be suitable for the glass type and have minimum warranty period of 10 years.

Ceiling Fans

- Ceiling fans should be avoided where possible. If necessary or approved, installation of ceiling fans shall comply with the following criteria:
- The minimum height of ceiling fans, measured to the underside of fan blades, shall be 2.4 metres from the finished floor level.
- Shall be located such that they do not detract on the performance of installed lighting
- Ceiling fan on/off switches, speed control and direction of rotation shall be controlled from wall mounted switches located at or near entrance doors / points.
- Shall be located at a height to suit their performance capabilities ensuring that they are effective and clear of any other ceiling mounted elements.

5.2.11 Toilet Fixtures & Fittings

Toilet suite and seat selection:

- Shall be of robust design suitable for the high level of use to be expected in a university environment
- Must be of make/supplier such that replacement units are able to be quickly supplied
- Particular attention is required to be paid regarding toilet seat selection. Fixings must be durable, have a sturdy fixing bracket and be proven to remain tight.

Hand Dryers

- Rapid dry hand dryers are to be used in all toilet and washroom areas. The selected dryer is to have a low noise level and HEPA filter.
- Paper towel dispensers are not to be used except in rare instances of particularly noise sensitive areas. The University of Melbourne Project Manager will advise the consultant on these occasions. In these rare instances, the University will supply the dispenser and the building contractor shall install.

Soap/Toilet Paper Dispensers

The University has standardised its use of toilet paper and soap dispensers across all buildings and campuses. The University shall supply soap and toilet paper dispensers and the building contractor is to install them.

- The University's cleaning contractor will stock and supply toilet paper, hand towel and soap in toilet and shower facilities.
- Toilet paper dispensers shall be installed to comply with relevant DDA requirements.

5.2.12 *Design Change Authorisation*

All requests for changes to the requirements of the Design Standards must be made on the modification request form. No design works to proceed on the basis of the proposed modification until the modification request has been approved in writing.

5.2.13 *As Built Information, Warranties and Manuals*

The University of Melbourne CAD Standards detail the formatting and submission requirements for as-built drawings, manuals and warranties.

The CAD Standards can be found in the Associated Documents Section of the Design Standards web page.

Projects will not be considered as being completed until the handover of all as-built documentation, manuals and related documentation which will comprise all information necessary to enable the safe and efficient ongoing operation and maintenance of the works.

The principal consultant or contractor is to provide the following information:

- Operation and maintenance manuals
- Any certificates of compliance.
- Routine and preventative maintenance requirements and schedules.
- All guarantees and warranty information, together with a summary table.
- For equipment and other supply items, the name and contact details of the company from which the item was purchased, and the local supplier and service agent.

Draft as-built information is to be provided 4 weeks prior to practical completion and final copy is to be provided no later than 4 weeks after practical completion.

SECTION 6: HYDRAULIC SERVICES CONTENTS

6.1	INTRODUCTION	2
6.2	HYDRAULIC SERVICES	2
6.2.1	Standards and Regulations	2
6.2.2	Drawings, Documentation and Technical Data Submissions	3
6.2.3	Spare Capacity within Hydraulics Services	4
6.2.4	Sanitary Plumbing Drainage and Fixtures	4
6.2.5	Trade Waste	4
6.2.6	Underground Pipework	4
6.2.7	Roof and Paved Surface Drainage System	4
6.2.8	Isolating Valves and Stop Cocks	4
6.2.9	Thermostatic Mixing Valves	5
6.2.10	Cold Water Services	5
6.2.11	External Drinking Fountains	5
6.2.12	Hot Water Services	5
6.2.13	Backflow Prevention Devices	6
6.2.14	Water Traps	7
6.2.15	Neutraliser Tanks	7
6.2.16	Water Metering	7
6.2.17	Laboratories	7
6.2.18	Colour Coding	8
6.2.19	Equipment Provided by the Hydraulics Contractor	8
6.2.20	Certification of Completed Work	8
6.2.21	Building Automation System (BAS)	8
6.2.22	Natural Gas Services	8
6.3	PROVISION OF GENERAL AMENITIES	9
6.3.1	Toilets	9
6.3.2	Toilet Flushing Systems	9
6.4	DESIGN CHANGE AUTHORISATION	9
6.5	OPERATIONAL MAINTENANCE, AS-BUILTS, WARRANTIES & MANUALS	10

6.1 INTRODUCTION

This section provides details of minimum requirements for the design, installation and operation of hydraulic services. The Designer is expected to produce their own specification incorporating the elements of the following information and submit all designs to the University for review prior to any tendering or works commencing on site. This design standard sets out the University's minimum requirements and shall be considered an adjunct to all relevant statutory regulations.

6.2 HYDRAULIC SERVICES

6.2.1 Standards and Regulations

All work shall meet all the requirements of national and local authorities and shall be in accordance with the following in so far as they apply to the work:

- Australian/New Zealand Wiring Rules AS/NZS 3000;
- SAA National Plumbing and Drainage Code AS 3500;
- AS 3500 Plumbing and Drainage;
- Gas Installation Code AS5601.1.

The design of hydraulic services shall comply with the table of relevant Australian Standards below:

System	Standards	Specific criteria to note
Domestic Sewer Drainage & Sanitary Plumbing	AS/NZS 3500.2 Plumbing Code of Australia	Minimum grade of 2.5% for 40-80mm, 1.65% for 100mm and 1% for 150mm pipelines. Fixture units to be assessed and pipework sized accordingly.
Stormwater	AS/NZS 3500.3 Plumbing Code of Australia	<p>Minimum grade of 1% for 100mm. Pipework sized accordingly.</p> <p>All overflows to be sized for the maximum year average (Average Recurrence Interval)</p> <p>Gutters sized to drain at 5% AEP (Annual Exceedance Probability) storm occurrence.</p> <p>In accordance with Green Star Credit 26.1, it is encouraged that the storm water systems are designed such that the storm water discharge does not exceed the pre-development peak event stormwater discharge using the average recurrence interval specified in the green star design. Management of storm water peak flows may include the following</p> <ul style="list-style-type: none"> • Storm water reuse • Water Detention <p>In accordance with Green Star Credit 26.2, it is encouraged that the storm water systems are designed such that the storm water pollution does not exceed the pre-determined pollution targets value in table 26.2 of the green star for untreated runoff. This is to be demonstrated via numerical modelling or</p>

		stormwater treatment performance calculations are provided manually.
Domestic Cold Water	AS/NZS 3500.1 Plumbing Code of Australia	Water velocity not to exceed 2.0m/s. Pressure range to each fixture between 200 – 500kPa. Installed in materials specified.
Domestic Hot & Warm Water	AS/NZS 3500.4 Plumbing Code of Australia	Water velocity not to exceed 2.0m/s. Pressure range to each fixture between 200 – 500kPa. Installed in materials specified.
Fixtures & Fittings	AS/NZS3500, AS1172.2, AS1432, AS1730, MP52	Watermark licensed. Accredited Australian Standards mark. To manufacturers requirements. Ergonomically suited for use. Installed in materials specified.

The scope of hydraulic services includes the following systems. Each is to be designed in accordance with the relevant Australian Standards and University of Melbourne Design Standards.

- Incoming water supply and tapplings including fire protection services;
- Domestic cold water supply reticulation and backflow prevention;
- Sanitary plumbing, drainage and fixtures;
- Stormwater drainage;
- Rainwater collection storage and treatment for reuse;
- Greywater / Blackwater collection for treatment and reuse;
- Solar hot water generation;
- Tempered water reticulation.
- Gas supply and reticulation.
- RO water plant and reticulation.
- Recycled water plant and reticulation.

6.2.2 Drawings, Documentation and Technical Data Submissions

All contractors are to submit full design shop drawings to the University of Melbourne Project Manager and consulting engineer for review and approval prior to commencing works on site.

The technical data for any equipment proposed by the consultant/contractor must be submitted to the University Project Manager with full details which must be inclusive of the following: -

1. Shop drawings including weights and dimensional sizing.
2. Pump curves (where applicable)
3. Maintenance schedule recommendations.
4. Life cycle of equipment
5. Relevant model numbers with all information to be installed on equipment for referencing on site.

6.2.3 Spare Capacity within Hydraulics Services

Provisions for 20% additional capacity shall be allowed for in all hydraulic services designs to cater for any future upgrades. Consideration of diversity must be factored in when designing such systems.

6.2.4 Sanitary Plumbing Drainage and Fixtures

No toilets or waste facilities shall be provided below the level of main sewer lines.

In situations where gravity drainage cannot be achieved a proprietary sewer pump chamber shall be provided. For individual bathroom groups a SaniFlo unit shall be specified.

6.2.5 Trade Waste

Trade waste shall be in accordance with the Australian Standards AS4494 and local water authority trade waste requirements. All trade waste applications to be submitted by project team prior to handover of completed works.

Grease interceptor trap (GITs) locations are preferred to be located externally away from all operable intakes and main entrances. however, grease traps that are located internally must be provided with sufficient ventilation in accordance with AS1668.2. A suitable and readily accessible location is to be provided for the GIT pump out.

6.2.6 Underground Pipework

All pipework laid underground alongside electrical cabling is comply with AS3500 and AS3000. The pipework shall be laid side by side and not on top of each other. Refer to colour coding section 6.2.18 for identification of pipework.

All trenches are to be backfilled to an appropriate level of compacting.

All underground stormwater and sewer pipework to be CCTV tested prior to practical completion.

6.2.7 Roof and Paved Surface Drainage System

The stormwater drainage system from roof and deck areas shall be designed in accordance with AS 3500.3. The rainfall intensity for design calculation shall use Bureau of Metrology 100 year return rainfall intensity plus 20% increase factor to allow for the potential effects of climate change. Provide drainage from planter boxes, and other hard and soft paved areas using a 1 in 20 year return rainfall intensity + 20% increase factor. Generally, drains shall gravitate to the legal point of discharge provided by the local council. Provide stormwater treatment as required by council prior to connection to the legal point of discharge.

It is desirable that rainwater collected from roof areas shall be stored in tanks of sufficient size to provide a water supply for irrigation. Toilet flushing and cooling tower use may also be considered.

The design of the roof drainage system shall generally utilise a gravity downpipe system. Where site constraints limit the feasibility of gravity drainage the designer shall consider the use of a syphonic drainage system.

6.2.8 Isolating Valves and Stop Cocks

All spurs off campus mains for water and gas supplying buildings, shall be fitted with tested isolating valves.

In the case where a building is supplied by a ring main, the main shall be capable of being isolated on either side of the tee-off position.

Stop cocks in hot and cold water lines and gas services shall be easily accessible and clearly marked. Separate stop cocks are necessary for each floor, groups of fixtures and for each laboratory on each floor of a building.

Ministops shall be fitted to connections for individual basins and sinks.

Isolating valves shall be fitted to all floors of a building to provide for domestic cold water and domestic heating hot water where applicable for any future connections.

Valves must be tagged to identify all service areas. Valves shall not be installed directly underground, they shall be in easily accessible areas for serviceability and isolation.

Isolation valves are to be provided at each floor when serving buildings that are multiple levels. If isolation valves are to serve laboratories then contractor must provide one (1) isolation valve per laboratory.

All cold-water isolation valves are to be in a location that is easily accessible for maintenance purposes. If they are to be in public areas then these isolation valves are to be lockable to avoid tampering.

Provisions for underground valves at each connection to buildings is a mandatory requirement, if the contractor is connecting into ring mains ensure that there are valves underground within the relevant spacing. All in ground valves are to be the anti-clockwise closing type.

6.2.9 Thermostatic Mixing Valves

Thermostatic mixing valves shall be provided to all ablution areas to reduce the hot water temperature to 50°C and, 42°C in disabled ablution areas. The mixing valves shall be in fully accessible locations within lockable stainless-steel wall boxes or accessible ducts complete with isolation valves. Mixing valves shall be located so that a maximum dead leg of 6 meters is not exceeded. Each TMV to be labelled with a traffolyte label indicating the area its serving. Tempering valves are acceptable in non DDA areas.

Mixing valves shall be Aquablend as supplied by Enware.

6.2.10 Cold Water Services

All cold-water systems must be designed in accordance with the relevant Australian Standards and must comply with this guide the University Design Standards.

If a new connection is requested the application must be submitted to relevant water authority.

The velocity of the water flow rate for cold water service must not exceed 2.0 m/s.

6.2.11 External Drinking Fountains

The standard type of external drinking fountains is the non-refrigerated type. These shall have cold water and sewer services connections to each fountain.

Drinking fountains are not to be installed directly on landscape floor, as a minimum a concrete pad shall be provided or if applicable they should be installed to any surface other than landscape floor.

Drinking fountains shall be by Aqua Bubbler – Classic model (AB128) in rich blue or approved equivalent. They shall be installed in accordance with the manufacturers specifications.

6.2.12 Hot Water Services

All hot water systems shall be efficient and designed to suit the building demand with additional spare capacity of at least 20% for future connections when required.

The University's preference is for hot water to be provided by solar hot water systems using evacuated tube type collectors with gas fired booster units. The reticulation system shall be a flow and return system fully insulated to comply with all requirements of the Building Code of Australia Section J and AS3500.4

An alternative option is heat pump domestic hot water units where suitable for the hot water duty required. The units are best located in warm environments such as boiler plant room to improve the efficiency of the heat pump.

Fixtures that are not practically served by a centralised system shall be supplied from electric hot water unit sized appropriately for the number and type of fixtures served.

Electrically operated hot water units shall not have automatic release buttons which operate on power failure. If these are provided on the unit they shall be removed before the unit is installed.

Hot water units shall be easily accessible for maintenance and all internal gas hot water systems shall be ventilated.

Hot water units shall be provided with safe trays. A waste connection is not required when a "Terminator" automatic shut off valve is fitted to the water inlet connection point.

Consultants and designers are to specify balancing valves that are to be installed on the return line to control and minimise any potential air noises and turbulence that may occur. This will also ensure that the temperatures that are controlled within the system are maintaining at least 60°C as a minimum.

Hot water service temperature deliveries shall be as follows: -

Area	Temp (°c)
Hot water plant	65
Return Water Temperature	60
Staff Showers & Staff Rooms	45
Staff Kitchen and Kitchenettes	50
Accessible Showers & Bathrooms	42
Commercial Kitchens	60

All heating hot water services pipework is to be provided with insulation that shall comply with AS3500.4. The insulation around bends shall be pulled as one piece where possible. All insulation is to be the high-performance type which shall also be provided to all joints, elbows and valves.

All hot water services installations must comply with the energy efficiency measures contained within the National Construction Code (NCC). All calculations are to be submitted to the University's Project Manager for review.

6.2.13 Backflow Prevention Devices

The required backflow prevention devices must be installed for each area that is deemed to be a high hazard. This should be installed at each property/site/building within the University to ensure containment protection is in place.

Backflow prevention devices must be tested every 12 months to ensure that they are operating effectively and to an acceptable standard. The following items are to be tested on each backflow prevention device prior to the expiry of the defects liability period.

Care needs to be taken regarding the cumulative pressure loss through multiple backflow devices or gravity fed systems. Pressure pumps may be required to overcome the system losses in some cases.

- A) Isolation valve
- B) Upstream non-return valves
- C) Relief valve
- D) Downstream non-return valve

6.2.14 Water Traps

All water traps must be primed to prevent smells from drip trays. Where possible floor wastes shall be primed from a local hand basin waste. Where no suitable primer source is available, an automatic trap primer valve shall be installed.

6.2.15 Neutraliser Tanks

The location of neutraliser tanks shall be convenient for vehicular access where pumping out is necessary. Generally, neutraliser tanks shall not be located in plant rooms. Associated dosing tanks shall be located where maintenance staff can gain access independently of any laboratory or office areas.

An adjacent cold water point and general purpose outlet shall be provided for mixing purposes. Ventilation of neutraliser tanks shall be such that any fumes do not re-enter the building.

Under bench neutralising tanks must be mobile with barrel unions on the inlets and outlets, and be easily removable for cleaning.

6.2.16 Water Metering

All new water meters and sub-meters are to be the smart type with pulsed outputs to ensure that real time data is as accurate as possible. These meters must be able to connect to the site wide BAS system.

Water meters are to be provided for potable and non-potable for the following areas - Buildings, precinct hot water systems, laboratories, commercial tenancies.

Sub meters are to be assembled within buildings to measure the following but not limited to: -

1. Centralised hot water systems
2. Centralised potable and non-potable systems
3. Rainwater harvesting systems
4. Irrigation systems
5. Tenancy areas
6. Cooling Towers
7. Boilers

All meters are to be in fully accessible locations for servicing and maintenance.

6.2.17 Laboratories

All laboratory tapware is to be selected from Enware or equal and approved colour coded tapware range with associated fixtures. The type of laboratory outlets is to be chosen in consultation with the University Project Manager.

All laboratories that include a wet area must be provided with safety showers and eye wash designated areas as per the manufacturer's instructions. The location of the safety shower is to ensure that this does not cause a slipping hazard to other occupants.

Each eye wash/safety shower shall be fitted with the appropriate isolation valve. In addition, the drainage shall be connected to sanitary plumbing via a floor drain. The design consultant shall avoid placing these systems near entrances/exits.

All systems that are designed/constructed must comply with the relevant laboratory standards. Refer to Design Standards Section 2 - Occupational Health and Safety.

RO pipe systems must incorporate valves at each level to ensure shutdown without affecting the building water supply. The water quality requirements shall be in accordance with AS4187. All RO systems designed to include a storage tank to prevent the impurity of the RO water.

6.2.18 Colour Coding

Plumbers, Mechanical and Electrical Subcontractors shall colour code and mark their services.

The design is to be in accordance with AS1345 for the identification and labelling of the services.

6.2.19 Equipment Provided by the Hydraulics Contractor

All equipment and materials supplied for incorporation into hydraulic services shall comply with the requirements of the relevant Australian Standards and University. All equipment shall be locally supported for spare parts and maintenance.

6.2.20 Certification of Completed Work

The hydraulic contractor shall issue upon practical completion of the works a Plumbing Industry Commission Certificate of Compliance nominating the works carried out on the project and hand the completed certificate to the University's Project Manager.

6.2.21 Building Automation System (BAS)

The following equipment where applicable shall be monitored under the BAS system but not limited to.

1. All tanks (rainwater, potable and non-potable) inclusive of low and high alarm.
2. Hot water plant (domestic hot water units) – temperature and fault status
3. All supply pumps – fault status.
4. Water Meters (where applicable).
5. Gas Meters (where applicable)

Refer to Design Standards Section 10 - BAS and Controls for more information about interfacing with other services and monitoring requirements.

6.2.22 Natural Gas Services

The natural gas supply and reticulation shall be designed in accordance with Australian Standards AS5601. The consultant/designer shall ensure that the gas supply demand for their project is adequate and that the existing infrastructure can meet the demands.

Any enquires must be submitted to the University and regulatory authority. Any new gas meters or regulators that are required to be installed shall be included within the projects scope and detailed design.

6.3 PROVISION OF GENERAL AMENITIES

6.3.1 Toilets

The number of WCs, urinals and lavatory basins shall be based on the expected population of the building. The distribution of anticipated students by sex shall be advised by the University Project Manager for the projects. Refer also to the Building Code of Australia.

Toilet paper and soap dispensers as detailed below. These will be supplied by the University however the project documentation is to provide for the building contractor to install.

- Twin Mini Toilet Roll Dispenser **TORK 472028**
- Foam Soap Dispenser **TORK 561500**

Hand dryers are to be specified. Paper towel dispensers are not to be installed except in exceptional circumstances (refer Section 5.2.11 of the Building Fabric section of the Design Standards). In such instances the dispensers will be supplied by the University and are to be installed by the building contractor.

- Slimline Handtowel Dispensers: **TORK 552030**

Toilet cubicle doors shall be in hold open position. Hinges shall allow for the ability to remove shut doors (cubicle occupied) in an emergency situation where the occupant becomes incapacitated.

Urinals shall be wall hung porcelain units unless otherwise approved by the University's Project Manager.

In female toilets, a space shall be made available for sanitary disposal units. These are supplied and installed by the University's Cleaning Services Manager. These units are free standing.

A shelf shall be provided in the wash-up area on which to rest books or bags.

Hooks and mirrors shall be provided.

A shower shall be provided in each building in a location approved by the University's Project Manager.

Indicator bolts shall be provided to all cubicle doors.

6.3.2 Toilet Flushing Systems

For toilet pans, install 'Zurn' flushers, or equal and approved equivalent, connected either to mains pressure or gravity fed flushing systems.

Consultants/contractors are required to provide dual flush valves for WC pans.

For urinals, install 'Zip Infrared Water Savers for Urinals,' or equal and approved equivalent. The infrared sensors shall be located over the urinal area and not in path of ingress/egress to avoid unnecessary flushing.

The Principal Consultant and Hydraulics Consultant shall discuss proposals based on the above guidelines with the University's Project Manager before commencing detailed design.

6.4 DESIGN CHANGE AUTHORISATION

All requests for changes to the requirements of the Design Standards must be made on the Modification Request Form. No design work is to proceed on the basis of a proposed modification until the modification request has been approved in writing.

6.5 OPERATIONAL MAINTENANCE, AS-BUILTS, WARRANTIES & MANUALS

For those projects targeting a Greenstar rating, the design consultant is to refer to Design Standards Section 3 - Sustainable Design for system commissioning requirements.

The design consultant **MUST** ensure that the project documentation includes a requirement for all hydraulic items to be provided with a full routine and regulatory maintenance period for 12 months from the date of practical completion. Any registrations of equipment are to be placed in the University's name prior to practical completion.

The University of Melbourne CAD Standards details of the formatting and submission requirements for as-built drawings, manuals and warranties. The CAD Standards can be found in the Associated Documents Section of the Design Standards web page.

Upon completion of projects all as-builts to be submitted to the University of Melbourne in both hard copy and soft copy format.

The Contractor shall provide operation and maintenance manuals containing (as a minimum) the following information for each item of equipment.

- Position/location;
- Duty;
- Means of isolating in an emergency;
- Complete manufacturer's details of unit and motor for the University's maintenance records, including Make and Model No.;
- Manufacturer's recommended maintenance procedures;
- Any other items, such as a spare parts list, provided with the unit;
- Guarantee and warranty information;
- Name of the company from which the item was purchased, the normal supplier and local service agent;

Draft manuals are to be provided four weeks prior to practical completion and final manuals are to be provided a maximum four weeks after practical completion.

SECTION 7: ELECTRICAL SERVICES CONTENTS

7.1	GENERAL	4
	7.1.1 Design Principle	4
	7.1.2 Heritage Requirements	5
	7.1.3 Standards and Regulatory Requirements	5
7.2	ELECTRICITY SUPPLY	7
	7.2.1 General Requirements	7
	7.2.2 Parkville Campus	7
	7.2.3 Southbank Campus	8
	7.2.4 Werribee Campus	8
	7.2.5 Burnley Campus	8
	7.2.6 Hawthorn Campus	8
	7.2.7 Other Campuses	8
	7.2.8 Supply Capacity	8
7.3	SWITCHBOARDS	8
	7.3.1 General Requirements	8
	7.3.2 Main Switchboards (MSB)	9
	7.3.3 Distribution Boards (DB)	12
	7.3.4 Mechanical Services Switchboards (MSSB)	13
	7.3.5 Switchgear	13
	7.3.6 Identification and Labelling	14
7.4	LOW VOLTAGE DISTRIBUTION	14
	7.4.1 General Requirements	14
	7.4.2 Consumer Mains and Submains	14
	7.4.3 Final Sub-circuits	15
	7.4.4 Busduct	15
	7.4.5 Earthing	15
	7.4.6 Cable Reticulation	15
	7.4.7 Labelling	18
7.5	POWER FACTOR CORRECTION	18
	7.5.1 General Requirements	18
7.6	ACTIVE HARMONIC FILTERS (AHF)	19
	7.6.1 General Requirements	19
7.7	METERING	19
	7.7.1 General Requirements	19

7.7.2	Multi-Function Meters Parameters	20
7.7.3	Supply Metering	21
7.7.4	Network Monitoring	22
7.8	ACCESSORIES AND EQUIPMENT	22
7.8.1	General Requirements	22
7.8.2	Lighting Switches	22
7.8.3	Isolating Switches	23
7.8.4	Switched Socket Outlets (SSO)	23
7.8.5	Emergency Power Off (EPO)	23
7.9	LIGHTING	24
7.9.1	General Requirements	24
7.9.2	Lighting Calculations	25
7.9.3	Switching	25
7.9.4	Occupancy Detection and Photoelectric Sensors	26
7.9.5	Lighting Control System	26
7.9.6	Control Gear	26
7.9.7	External Lighting General Requirements	27
7.10	EXIT AND EMERGENCY LIGHTING	28
7.10.1	General Requirements	28
7.10.2	System Description	28
7.10.3	Wireless Communications	Error! Bookmark not defined.
7.10.4	Exit and Emergency Luminaires	28
7.10.5	Wireless Station	Error! Bookmark not defined.
7.10.6	System Server	Error! Bookmark not defined.
7.10.7	System Graphics	28
7.11	STANDBY POWER SYSTEMS	29
7.11.1	General Requirements	29
7.11.2	Standby Generator	29
7.11.3	Uninterruptable Power Supply (UPS)	29
7.12	PHOTOVOLTAIC (PV) SYSTEMS	30
7.12.1	General Requirements	30
7.12.2	System Delivery	30
7.12.3	Site Assessment	30
7.12.4	Roof Access	30
7.12.5	System Design	30
7.12.6	Mounting and Location	31
7.12.7	System Rating and Capacity	31

7.12.8	Supply Authority Approval	31
7.12.9	Equipment Requirements	31
7.12.10	System Voltage Drop/Rise	32
7.12.11	Earthing and Lightning Protection	32
7.12.12	Warranty Periods	32
7.13	TESTING, COMMISSIONING AND OPERATIONAL MAINTENANCE	33
7.13.1	General Requirements	33
7.13.2	Testing and Commissioning	33
7.13.3	Building System Tuning	34
7.13.4	Samples, Technical Data Sheets and Shop Drawings	34
7.13.5	Operational Maintenance and Operation & Maintenance Manuals (O&M)	35
7.13.6	Design Change Authorisation	36
7.14	MATERIAL SELECTION	36

7.1 GENERAL

This section provides details of mandated minimum requirements for the design, installation and operation of Electrical Services. The Engineer/Consultant is expected to produce their own specification incorporating the elements of the following information and submit all designs to the Manager Engineering and Infrastructure for review prior to tendering or any works commencing on site. This Design Standard sets out the University's minimum requirements and shall be considered an adjunct to all relevant statutory regulations and codes relevant to the works.

The Engineer/Consultant must use the Modification Request Form to obtain approval for any departure from any clause in this Design Standard.

All works, irrespective of the nature of the installation, shall incorporate value engineering in respect to energy saving, maintenance costs etc.

The Engineer/Consultant shall read this Electrical Services Design Standard in conjunction with the other sections of the University's Design Standards document.

Should any discrepancy occur between this section and other sections of the Design Standard or any of the mandatory requirements on the Australian Standards listed in Section 7.1.2 the more onerous requirement shall be adopted.

This section of the Design Standards includes:

- Electrical Switchboards (MSB, DB, MSSB)
- Low Voltage (LV) Distribution
- Power Factor Correction (PFC)
- Active Harmonic Filtering (AHF)
- Metering and Energy Monitoring
- Accessories and Equipment
- Lighting and Lighting Control Systems
- Exit and Emergency Lighting
- Stand-by Power Systems
- Photovoltaic Systems (PV)
- Testing, Commissioning and Operational Maintenance

It does not cover the following items;

- High Voltage (HV) distribution.
- Information Technology, Telecommunications and Communications. Refer to Section 21 - The University of Melbourne Computer and Network Accommodation Strategy (CANAS) standard, and Section 20 - The University of Melbourne Standards for the Installation of Telecommunications Networks document.
- Audio Visual systems and technologies. Refer to Section 18 – Audio Visual Services Design Guidelines.
- Theatrical lighting technologies and control systems.
- Freezer Farm Mechanical system design. Refer to Section 16 - Laboratory Refrigerator and Freezer Design Standards

7.1.1 Design Principle

Electrical systems are to be designed in accordance with the requirements of the Design Standards. The systems are to be designed and installed in a safe manner which simplifies future maintenance and replacement. Systems are to be designed and installed to meet current and expected future capacity requirements. In general, the

future capacity requirements for major infrastructure (i.e. consumer mains, MSB etc.) is 30%, however in some circumstances additional (or less) may be required. Any future capacity requirements must be confirmed with the Manager Engineering and Infrastructure. All new systems shall be designed and installed such that major modification is not required to extend the system.

In accordance with Green Star Design and As-Built Credit 3.1, it is encouraged that Electrical systems are designed such that they are resilient to the impacts of a changing climate and natural disasters. A Climate Adaptation Plan may be required (refer Section 3: Sustainable Design).

Refer to Section 3: Sustainable Design for details of the University's Greenstar requirements

Application of Green Star credits

The Green Star credits referred to in this section apply, at a minimum, to new buildings and major building refurbishments.

7.1.2 Heritage Requirements

Contractors shall note that various buildings on the campuses are heritage protected. Electrical system installation methods in these areas require approval by the Heritage Consultant and the University's Project Manager prior to any installation.

The contractor is to minimise interference with the original building fabric and is to note original architectural details and locations and record as necessary to ensure accurate and complete reinstatement.

All wiring shall be concealed within existing wall cavities. Where wall chases are unavoidable, proposed wall chases shall be marked and approval sought prior to proceeding.

A list of heritage listed buildings is available from the Heritage of Council Victoria and local Municipal Council's website.

7.1.3 Standards and Regulatory Requirements

This section provides details of the main Standards and regulatory requirements for the design, installation and operation of electrical systems. The list is not exhaustive and the Engineer/Consultant is required to ensure that the requirements of all the relevant Standards and regulating requirements are complied with;

Code	Description
AS/NZS 1158 Set	Code of Practice for Public Lighting
AS/NZS 1170.4	SAA Loading Code - Earthquakes
AS/NZS 1345	Identification of the Contents of Piping, Conduits and Ducts
AS/NZS 1627 Set	Metal Finishing - Preparation and Pre-treatment of Surfaces
AS/NZS 1680 Set	Interior Lighting
AS/NZS 1768	Lightning Protection
AS/NZS 1882	Earth and Bonding Clamps
AS/NZS 1939 Set	Degrees of Protection (IP Code)
AS/NZS 2053	Conduits and Fittings for Electrical Installations

AS/NZS 2067	Substations and High Voltage Installations Exceeding 1 kV A.C.
AS/NZS 2756	Low Voltage Switchgear and Control Gear
AS/NZS 2243	Safety in Laboratories
AS/NZS 2293 Set	Emergency Evacuation Lighting in Buildings
AS/NZS 2676	Installation and Maintenance of Batteries in Buildings
AS/NZS 2785	Suspended Ceilings, Design and installation
AS/NZS 2982	Laboratory Design and Construction
AS/NZS 3000	SAA Wiring Rules
AS/NZS 3008	Electrical Installations – Selection of Cables
AS/NZS 3010	Electrical Installations – Generating Sets
AS/NZS 3012	Electrical Installations – Construction and Demolition Sites
AS/NZS 3017	Electrical Installations — Verification Guidelines
AS/NZS 3019	Electrical Installations — Periodic Verification
AS/NZS 3100	Approval and Test Specification – General Requirements for Electrical Equipment
AS/NZS 3111	Approval and Test Specification for Miniature Overcurrent Circuit-Breakers
AS/NZS 3140	Approval and Test Specification - Edison Screw Type Lamp Holders
AS 3439.1	Low Voltage Switchgear and Control Gear Assemblies
AS/NZS 3820	Essential Safety Requirements for Electrical Equipment
AS/NZS 3947.3	Low-Voltage Switchgear and Control Gear - Switches, Disconnectors, Switch-Disconnectors and Fuse-Combination Units
AS 4282	Control of The Obtrusive Effects of Outdoor Lighting
AS/NZS 4680	Hot-Dip Galvanized (Zinc) Coatings on Fabricated Ferrous Articles
AS/NZS 4777 Set	Grid Connection of Energy Systems Via Inverters
AS/NZS 4792	Hot-Dip Galvanized (Zinc) Coatings on Ferrous Hollow Sections, Applied by a Continuous or a Specialized Process
AS/NZS 5000 Set	Electric Cables - Polymeric Insulated - For Working Voltages Up to and Including 0.6/1 kV
AS/NZS 5033 Set	Installation and Safety Requirements for Photovoltaic (PV) Arrays
AS/NZS 60598 Set	Luminaires
AS/NZS 60921 Set	Ballasts for Tubular Fluorescent Lamps - Performance Requirements
AS/NZS 60922 Set	Auxiliaries for Lamps - Ballasts for Discharge Lamps - General and Safety Requirements

AS/NZS 60923	Auxiliaries for Lamps - Ballasts for Discharge Lamps - Performance Requirements
AS/NZS 60925	D.C. Supplied Electronic Ballasts for Tubular Fluorescent Lamps - Performance Requirements
AS/NZS 61000 Set	Electromagnetic Compatibility
AS/NZS 61048	Auxiliaries for Lamps - Capacitors for Use in Tubular Fluorescent and Other Discharge Lamp Circuits - General Safety Requirements Capacitors for Use in Discharge Lamp Circuits
AS/NZS CISPR Set	Electromagnetic Compatibility

Comply fully with all relevant Standards and Regulatory Codes published and in force at the time of construction, including the following:-

- The Commonwealth and State Electricity Acts and Regulations
- Victorian Service and Installation Rules
- Victorian Electricity Distribution Code
- Occupational Health Safety & Welfare Act and Regulations
- National Construction Code (NCC)
- Electricity Supply Authority Service Rules and Conditions of Supply
- Energy Safe Victoria Regulations and Legislation
- Disability Discrimination Act (DDA)
- All Local Council regulations
- Worksafe Victoria
- Environment Protection Authority
- Australian Communications Authority (ACA)

7.2 ELECTRICITY SUPPLY

7.2.1 General Requirements

Distribution of services to new buildings should be via crawl culverts or tunnels connected to adjoining existing buildings, where possible.

The Consultant/Engineer shall prepare Single Line Diagrams for the entire distribution system. Calculations and a report shall be prepared to support the correct settings/rating, operation and discrimination of protective devices and be made available on request.

The Consultant/Engineer shall prepare fault level calculations estimating the fault level at all parts of the electrical distribution system. The fault withstand of the distribution equipment shall be specified in accordance with the results of the calculations.

The Consultant/Engineer shall observe appropriate segregation of circuits at different voltages for safety and avoidance of electromagnetic interference. It should be noted that certain University buildings and equipment are sensitive to electromagnetic interference.

7.2.2 Parkville Campus

The Parkville campus is provided with twenty-five (25) indoor CitiPower substations with various ratings and arrangements. LV electricity supply is distributed from the substations to buildings via precinct/building level Main Switchboards (MSB).

7.2.3 Southbank Campus

The Southbank campus is provided with five (5) indoor CitiPower substations with various ratings and arrangements. LV electricity supply is distributed from the substations to buildings via precinct/building level Main Switchboards (MSB). In addition to the substation supply, the Southbank campus is also provided with LV street supplies serving peripheral locations on the campus.

7.2.4 Werribee Campus

The Werribee campus is provided with two (2) CitiPower/Powercor substations. One (1) substation is in an open bush arrangement with the other in an indoor arrangement. LV electricity supply is distributed from the substations to buildings via precinct Main Switchboards (MSB).

7.2.5 Burnley Campus

The Burnley campus is provided with one (1) CitiPower substation. LV electricity supply is distributed from the substation to buildings via a precinct Main Switchboard (MSB).

7.2.6 Hawthorn Campus

The Hawthorn campus is provided with one (1) CitiPower substation. LV electricity supply is distributed from the substation to buildings via a precinct Main Switchboard (MSB).

7.2.7 Other Campuses

The remainder of the campuses (Dookie, Shepparton, Creswick) are generally provided with Supply Authority LV street supplies.

7.2.8 Supply Capacity

The supply capacity adequacy must always be assessed prior to proceeding with detailed design of all minor and major projects. For new installations, approval must be provided by the Manager Engineering and Infrastructure for all new points of connection.

All projects require the existing and new maximum demand calculations to be provided to the Manager Engineering and Infrastructure for review. An increase in supply capacity must be requested by the Consultant/Engineer to the Electrical Supply Authority. The Consultant/Engineer shall liaise with the Supply Authority and assist the University with negotiations, including submission of applications, relating to reinforcement of existing and new electrical supplies.

All new connections (including new substations) shall be provided with 30% spare capacity for future growth. In some instances, spare capacity greater than 30% may be required. The spare capacity provision must be approved by the Manager Engineering and Infrastructure prior to design commencing.

7.3 SWITCHBOARDS

7.3.1 General Requirements

This section applies to all new MSB's, DB's and MSSB's. All new switchboard locations shall be approved by the Manager Engineering and Infrastructure prior to implementation.

New MSB's shall be installed within a 2-hour fire rated room. MSB rooms shall be provided with a thermostatically controlled fan for ventilation. Temperatures within the MSB room shall be kept below 35 degrees to avoid derating of switchgear. MSB room

doors shall be provided with the University Bi-Lock key system. MSB rooms to be provided with adequate space for Power Factor Correction (PFC) and Active Harmonic Filter (AHF) units.

MSB rooms installed in basement levels shall be above flood levels and shall be provided with bunding (minimum 200mm) at the entry doors to prevent water entering the MSB room. Basement level MSB rooms shall be provided with adequate drainage with drip detection. Any moisture detected within the drain shall raise an alarm to the BAS via a low-level interface connection. Signage shall be provided on MSB room doors, the signage shall read 'MAIN SWITCHROOM'. In general, MSB rooms shall not be established in areas subject to flooding and moisture ingress.

All new DB's shall be installed in cupboards and in accessible areas. DB's shall not be installed in enclosed rooms (other than plant rooms) or offices. DB's installed in a path of egress shall be provided with smoke seals. Cupboard doors to be provided with University Bi-Lock. Signage shall be provided on cupboard doors indicating the content of the cupboard.

All new switchboard installations shall be scanned with a thermographic camera immediately when the switchboard is energised and is at full load. Further scans are required six (6) months into the Defects and Liability Period (DLP) and four (4) weeks prior to the end of the DLP.

The thermographic scans shall be undertaken on the following;

- Exterior of switchboard
- Cable terminations
- Busbar links
- Switches
- Isolating links
- Circuit breakers

Any abnormalities shall be immediately reported to the Manager Engineering and Infrastructure and shall be rectified without delay.

Thermographic scan photos and report shall be submitted to the Manager Engineering and Infrastructure.

7.3.2 Main Switchboards (MSB)

The MSB shall be specified as a custom-built type-tested assembly and shall be designed to comply with the requirements of AS3000, AS61439, AS3947 and the additional requirements of the University as set out in this Design Standard. Modular construction MSB's are not permitted.

MSB enclosures shall meet the requirements of the relevant Australian Standard for the degree of protection. Generally, the Form of segregation for a MSB with ratings of 800 Amps and above shall be Form 3B (Form 3B IH will not be accepted), for lower rated MSB's it shall be Form 2A. Modular construction MSB's are not permitted.

Adequate support shall be provided for all busbars and the like to withstand the stresses caused by a prospective maximum fault current of not less than 50 kA for one second.

Tenderers are required to submit full details of the switchboard with their tender, together with the name of the testing authority and relevant information regarding the fault current rating of the switchboard. A type test certificate must be provided for all new MSB's.

Prior to manufacturing the MSB, comprehensive shop drawings, together with all relevant data relating to the proposed MSB, shall be submitted to and approved by the Manager Engineering and Infrastructure.

Switchboard design shall incorporate the following:

- The Engineer shall confirm the University's requirement for spare capacity during the design phase.
- Conductors of fire and smoke control equipment, evacuation equipment and lifts shall be segregated, and in a separate switchboard compartment. Provide adequate labelling in accordance with AS/NZS 3000.
- Cubicles to be manufactured from 2mm mild steel, folded and welded where required to form a rigid self-supporting structure.
- Doors to be manufactured from 2mm mild steel and fixed with chrome plated lift off block hinges and secured with chrome plated knurled captive head machine screws.
- The MSB shall be mounted onto a fixed galvanised dipped plinth manufactured from 75mm x 40mm channel iron.
- Louvred vents shall be provided fitted with fine filter material and perforated metal filter support which is to be vermin proof (whilst maintaining the IP protection rating).
- Gland plates shall be manufactured from 3mm aluminium, sealed with a gasket and bonded to earth.
- Busbars shall be manufactured from high conductivity (HCU) full radius edge or radius corner copper busbar. Joints to comply with test requirements using metric high tensile (grade 8.8) bolts and nuts.
- All busbars and busbar assemblies shall be designed to limit the rise in temperature to no more than 50°C above a 40°C ambient temperature when carrying the maximum current rating of each and all associated items of switchgear.
- All busbar supports shall be capable of supporting busbars for a temperature range of 15°C to 110°C in continuous service;
- Neutral busbars shall have the same current carrying capacity as the phase conductors;
- Readily removable busbar links shall be provided for specified current transformers;
- Busbars for the red, white and blue phases shall be colour coated. Colouring shall be by means of heat shrink (Thermoshrink or approval equivalent). Strips or bands of heat shrink shall be utilised to identify the neutral and earth conductors.
- Busbars shall extend to all spare poles/ways. The busbar rating shall be sized to the maximum pole capacity i.e. the busbar assembly serving a 400 Amp spare way/pole shall also be sized to 400 Amps.
- All joints, terminations and fixings shall be fully accessible.
- Provision shall be provided for 30% future expansion of the main busbar system; all junctions associated with the installation of copper busbar shall be established using full lap-joints or compression joints. Lap joints shall be secured using torqued bolt fasteners. Clamp joints will not be accepted.
- All 'live' sections of a main switchboard, within wiring chambers, etc. shall be fully insulated to prevent contact with live parts.
- Provide LED indicator lights to identify if all three (3) phases of mains power is available. The LED lights shall be Red, White and Blue.
- Control of outgoing supplies shall be as follows:
 - up to 800 Amps – moulded Case Circuit Breaker
 - 800 Amps and over – withdrawable Air Circuit Breaker

- The provision of a positive air ventilation system for the main switchboard room to minimise dust entry shall be considered. This requirement shall be confirmed with the Manager Engineering and Infrastructure.
- Internal switchboards shall be provided with protection to AS 1939 IP42.
- External switchboards shall be provided with protection to AS 1939 IP56.
- Free-standing MSB's with rear access shall be provided with rigid removable panels with lifting handles and captive knurl-headed fixing screws.
- Removable panels shall be supported by locating dowels or pins to provide support for the panel when the fixing bolts are removed.
- Provide surge protection.
- All new MSB's shall be Storm Grey in colour.
- Shall be installed and configured in accordance with all statutory requirements, and the Supply Authority requirements.
- All new MSB's shall be of one of the following approved manufacturers;
 - Aline
 - R.G Ladd
 - LAI Switchboards
 - Trinity Switchboards
 Alternatives will not be accepted.

Switchboard labelling

All switchgear, apparatus, terminal strips and controls shall be labelled in accordance with the Supply Authority's requirements and to the following:

Lift-off panels shall be labelled to identify their location on the main switchboard.

Labels shall be provided for Safety/Essential Services, which are deemed to include the following:

- Fire protection equipment;
- Fire indicating panel;
- Passenger elevators;
- Circuits supplying computer LAN, WAN or computer equipment;
- Circuits controlling emergency luminaires;
- Circuits controlling security or building access control equipment;
- Main switches controlling safety services shall be identified to indicate the equipment that they control and be marked 'IN THE EVENT OF FIRE, DO NOT SWITCH OFF'.

Traffolyte labels shall be installed on the front doors and shall be fixed with chrome-plated screws. The labels shall indicate the capacity of the unit, the rating of installed protective devices and the outgoing cable reference. Labels shall also be installed adjacent to the load terminals.

All essential safety services are to be colour coded separately. Labelling colours are defined as follows:

- GENERAL: Black lettering on white background;
- MAIN SWITCH AND CAUTION: Red lettering on white background;

- DANGER/WARNING LABELS: White lettering on red background.

Schematic Wiring Diagram

The Engineer/Consultant shall prepare a schematic wiring diagram of the complete switchboard. The wiring diagram shall include, but shall not be limited to, the following information:

- Main switch capacity, rating and trip settings
- Circuit breaker capacities, rating and trip settings
- Size and capacity of busbars
- Capacity, rating and arrangement of incoming supply
- Capacity, rating and arrangement of outgoing circuits
- Destination of submain supplies
- Size of main earth conductor and location of main earth electrode
- Type test rating of the Main Switchboard

An A1 laminated and framed copy of the Single Line Diagram shall be mounted within the MSB room adjacent the MSB.

7.3.3 Distribution Boards (DB)

Distribution boards shall generally be proprietary type panel boards constructed to Form 1 specifications and shall be manufactured by NHP or Schneider unless otherwise approved via a Modification Request Form.

100% spare pole capacity shall be provided for all distribution boards (i.e. 50% full). This may be reduced in some instances with the approval of the Manager Engineering and Infrastructure.

Circuit breakers controlling final sub-circuits shall be manufactured by NHP or Schneider. Installation of lock dogs for all circuit breakers controlling special equipment shall be specified.

The installation of Duplex circuit breakers is not permitted.

All new DB's shall have the following:

- Isolating main switch to control each distribution board shall be provided.
- Busbars shall be type tested to a minimum of 20kA for 0.2 second.
- Split lighting and power chassis with 100% spare pole capacity
- Separate Power Monitoring Units (PMU) for lighting and power chassis. PMU's to be open protocol.
- Form 1
- IP42 for internal installations
- IP54 for external installations
- Front connected
- Cable entry and cable exit via gland plates
- Hinged doors (lift-off panels will not be accepted)

Freezer Farm rooms shall be provided with a dedicated distribution board. Each freezer and laboratory fridge shall be provided with a non-RCD protected dedicated final sub-circuit originating from the Freezer Farm distribution board, refer to the relevant section in AS3000 for non-RCD protected circuits. Where a Freezer Farm distribution board is not provided, a dedicated circuit shall be provided per fridge/freezer.

7.3.4 Mechanical Services Switchboards (MSSB)

In addition to the requirements of Section 7.3.3, all new MSSB's shall be Form 1, 2 or 3B to AS/NZS 61439 as required by the project. MSSB's with a supply of 800A or greater shall be Form 3B or a combination of Form 3B and Form 2. Final approval of the Form rating shall be provided by the Manager Engineering and Infrastructure.

Switchboards with Form 3B segregation shall be as per the University's requirements as described in Section 7.3.2 for main switchboards.

MSSB are to be generally located within plant rooms/electrical riser cupboards and must be in well ventilated areas. Externally located MSSB's must be marine grade, corrosion resistant or 3CR12 corrosion resistant steel construction and fitted with a sloped roof covering the entire MSSB with doors in open location.

All new MSSB's shall have the following:

- Isolating main switch shall be provided.
- Busbars shall be type tested to a minimum of 10kA for 0.2 second.
- 25% spare capacity in all compartments
- Form 2 or 3B (or a combination of 2 and 3B) for the mains distribution with input, output and functional units segregated using metallic compartments behind separate covers.
- IP54 for internal and external installations
- Front connected
- Cable entry and cable exit via gland plates
- Ventilation louvres on doors with internal mesh filters.
- Electrical orange X15 colour exterior with white internal escutcheon
- Green LED light for system RUN and Red LED light for system in FAULT. Lights to be mounted on the front of the MSSB.

7.3.5 Switchgear

All switchgear shall be manufactured and tested in accordance with the relevant Australian Standards. Switchgear and protection equipment must be of a uniform manufacture in any single installation. Switchgear ON/OFF positions must be visible when the switchboard escutcheon is closed. Circuit breakers and protection equipment must be of NHP or Schneider manufacture.

- For loads 10 Amps up to 100 Amps, Miniature Circuit Breakers (MCB) shall be used. DIN mounted MCB's with integral RCD protection within a single pole shall be used
- For loads 100 Amps to 800 Amps, Moulded Case Circuit Breaker (MCCB) shall be used.
- For loads above 800 Amps, withdrawable Air Circuit Breakers (ACB) shall be used.

Discrimination and cascading

All protection devices shall be selected to enhance discrimination and avoid cascading between upstream and downstream devices. It shall be arranged so that only the protection device immediately upstream of the fault shall operate to clear the fault.

A discrimination study shall be provided as part of the switchboard shop drawing submission to confirm all circuit protection selections and settings.

7.3.6 Identification and Labelling

All new switchboards shall be provided with permanently fixed traffolyte labelling indicating the name of the switchboard. All new switchboards shall adopt the following naming convention; BNXXX.DB.Y-Z

Where XXX is the building number, Y is the floor number and Z is the switchboard number. Note MSSB shall be used instead of DB for mechanical switchboards.

In addition to the name label, the MSB and MSSB's shall be provided with a label showing the following minimum information;

- Rated current
- Rated voltage
- Short circuit fault current withstand
- Form rating
- IP rating
- Date of manufacture
- Supply mains size and arrangement
- Source of supply
- Miscellaneous equipment i.e. surge protection, time clocks, contactors etc.
- Main isolator rating
- Submain supply protection device
 - label to indicate name of switchboard being supplied
 - rating and protection setting
 - cable size

7.4 LOW VOLTAGE DISTRIBUTION

7.4.1 General Requirements

All new LV distribution systems shall be designed and installed to comply with the requirements of AS3000 and AS3008. Distribution systems shall be designed taking into consideration; current carrying capacity requirements, voltage drop and short circuit temperature rise.

A maximum of 5% voltage drop is allowed from substation to final sub-circuit, in some instances 7% may be used, however this needs to be approved by the electrical supply authority and the Manager Engineering and Infrastructure. The following voltage drop limits are applicable to all new and existing installations;

- Consumer mains – no greater than 1%
- Submains – no greater than 1.5%
- Final sub-circuits – no greater than 2.5%

All new cabling shall be copper, aluminium cabling is not permitted.

Any redundant cabling shall be must be removed from site.

7.4.2 Consumer Mains and Submains

Current carrying capacity of consumer mains and submains shall suit the maximum demand in addition to 30% spare capacity, in some instances more than 30% may be required. Final approval shall be provided by the Manager Engineering & Infrastructure.

Cable joins are generally not permitted, however if necessary, all cable joins must be;

- Approved by the Manager Engineering and Infrastructure

- Located in an accessible location
- In internal installations, only bolted joints with removable copper links will be accepted. The join must be enclosed within a sheet metal junction box with removable/openable door.
- In external installations, the join must be enclosed in a cable pit.

In-line joins and crimping of cables are not permitted.

All new consumer main cables shall be fire rated.

7.4.3 Final Sub-circuits

General power circuits shall be wired in not less than 2.5mm² (Cu PVC/PVC or TPS minimum). Cable colour to be black.

General light circuits shall be wired in not less than 2.5mm² (Cu PVC/PVC or TPS minimum). Cable colour to be white.

7.4.4 Busduct

Copper conductor busduct systems may be used in certain installations where appropriate. In general, busduct may be used to supply high current, non-fire rated loads. Final approval of the use of busduct to be provided by the Manager Engineering and Infrastructure.

7.4.5 Earthing

Protective earth cabling shall be in accordance with the requirements of AS3000.

All new substation installations require a new M.E.N to be installed within the substation, final sign-off shall be provided by Supply Authority.

Upgrade of existing MSB's connected to existing substations shall also include the establishment of a new M.E.N within the substation, final sign-off shall be provided by Supply Authority.

7.4.6 Cable Reticulation

Trench excavation, backfilling and compaction

Distribution of services to new buildings should be via crawl culverts or tunnels connected to adjoining existing buildings, where possible.

Drawings for existing underground services installed across the Parkville Campus are available from Campus Services and are to be used as a guide only, a detailed survey of the underground services is required to be undertaken prior to any excavation works.

New trenches shall be coordinated with existing underground services. Any trenching works shall be approved by the Manager Engineering and Infrastructure prior to commencement. Trenches shall be straight and parallel with the buildings, roadway, etc. Bitumen and concrete surfaces shall be cut prior to excavation by a concrete saw or similar. All surplus excavated spoil shall be removed from the site. All effected surfaces shall be reinstated to existing (or better) condition.

Underground cabling shall be installed in heavy duty non-metallic conduits in accordance with AS3000 and the following additional requirements:

- The minimum depth of laying and protection for underground wiring shall be 600mm (cover) below finished ground level.

- Conduits shall be embedded in a layer of clean washed sand to a minimum cover of 100mm followed by premium grade crushed rock in brick, concrete, bitumen areas or premium top soil in garden areas.
- Marker tape shall be provided laid between 100mm and 200mm above the conduits. Trenches shall be allowed to remain open for the minimum length of time required for laying the conduits and cabling with due allowance for inspection. PVC marker tape complying with AS2648 part 1 shall be specified for cable trenches.
- Backfilling shall not commence until the laying of the conduit has been approved by the Manager Engineering and Infrastructure. The backfilling shall be compacted to 95% AASHO.
- All conduits shall be complete with suitable expansion couplers and suitable care shall be taken where conduits enter buildings to allow for earth/building movements. Conduits entering buildings shall be correctly sealed to ensure moisture does not enter the building from the outer perimeter of the conduit.
- Conduits located in hazardous areas shall be resistant against hydrocarbons and of type heavy duty fuel resistant 'Nupi Smart Conduit' or equivalent.
- Conduits shall be installed with suitable falls to allow for drainage
- Conduit segregation distances shall exceed the requirements of ACMA Regulations.
- After installation of cables all conduits shall be sealed to prevent ingress of dirt and moisture.
- Spare conduits shall be provided with draw wires and capped for future use.

50% spare conduits shall be provided in trenches, the final quantity of spare conduits shall be approved by the Manager Engineering and Infrastructure.

Cable markers shall be round stainless-steel flush type, complete with directional arrow. Markers to be provided every 20m in straight runs, where trenches change direction and where cables enter/exit buildings. Markers shall be selected from the Gatic range or as otherwise approved in writing by the Manager Engineering and Infrastructure.

The Contractor shall be responsible for the proper disposal (from the site) of all spoil and associated waste materials excavated during the project. The Contractor shall allow under the Contract to keep the Works Area clean and tidy and shall regularly remove from the site rubbish and surplus material arising from the execution of the work.

As-installed drawings must be provided for any underground conduit/cabling works.

Cable pits

Cable pits shall be installed at all changes in direction and at a maximum of 50m intervals.

Load Class C (minimum) pits shall be provided in trafficable areas in accordance with AS3996. New pits shall be constructed of steel reinforced pre-cast or in-situ cement concrete/fibre cement concrete. Pit lids to be heavy duty, cast iron with concrete/brick/pavement infill of Gatic manufacture.

Water ingress gaskets shall be provided to all new pit lids.

The pits shall be provided with drainage holes, located at the bottom of the pit to remove any ingress water. The Contractor shall ensure that sufficient drainage is provided to all pits, and to prevent water drainage through the conduits. This shall be undertaken in coordination with the pit manufacturer to ensure the integrity of the pit is maintained.

Provide embossed lids to all pits stating the contents of the pit i.e. 'ELECTRICAL PIT', “.

Pit lids are to be installed such that they do not cause a trip hazard and are flush with the existing surrounding area.

Underground cabling

Cables specified for underground wiring shall generally be elastomer or thermoplastic insulated with elastomer or thermoplastic sheathing (double insulated) complying with the relevant Australian Standard for underground cables, be enclosed in heavy duty rigid UPVC conduit and installed in Category A wiring system.

Cable trays and ladders

New cable trays and ladders shall be provided with 50% spare capacity.

All consumer mains and submains shall be installed on cable trays. Main runs of final sub-circuits are to be installed on cable trays.

Minimum steel thickness:

- Trays up to 150mm wide: 1.0mm
- Trays from 150mm to 300mm wide: 1.2mm
- Trays over 300mm wide: 1.6mm

The cable tray shall be galvanised steel with 20mm (minimum) high folder edges.

Slots or ladder rails shall be suitable for fixing cable ties, strapping or saddles.

Position cable tray supports to give adequate access for inspecting, replacing, or adding cable.

Provide a curved support surface under cables leaving the tray or cable ladder to protect the cable sheath from any sharp edges tray or ladder.

Segregation from communications, security etc. cabling shall be provided in accordance with the relevant standards.

Fire rated cables shall be installed in accordance with AS3000 and AS3013. Cables shall be fixed with certified steel cable ties with maximum 1000mm centres.

Earth all cable trays, ladder trays in accordance with the requirements of AS3000.

Conduits

Conduits shall not be installed in visible locations (i.e. on internal/external walls, ceilings and floors). Conduits shall be concealed in wall cavities, chased into floor slab.

Use metallic conduits in locations where mechanical damage is possible. All metallic conduits shall be galvanised steel in accordance with AS1074.

All conduits shall be mounted using dual fixing saddles spaces at a maximum of 1m intervals.

Flexible couplings shall be used at building expansion joints and in straight runs where mounted to a wall.

All spare conduits shall be provided with draw wires for future cable reticulation.

All conduits shall be sealed to avoid water ingress.

Floor boxes

Floor boxes shall be flush mounted, with hinged removable lids. Heavy duty floor boxes shall be specified in areas where heavy machinery may be used i.e. cherry picker etc. floor boxes shall be suitably selected to be fit for purpose in nominated areas.

Floor boxes locations shall avoid structural beams, sign off from a structural engineer is to be obtained prior to any on-site works.

All new floor boxes shall be of ECD manufacture.

Table boxes

Table boxes shall generally be provided by the joinery trade. In the instances where they are provided by the electrical trade, the table box shall be of ECD manufacture.

Table box power outlets to be soft wired using ECD manufactured equipment.

Under no circumstances shall power outlets be hard wired to tables.

Skirting duct

Skirting duct shall be made from extruded aluminium with drop in cover plates complete with powder coated finish to suit the wall colour

All new skirting duct to be provided with two (2) compartments for power and data cabling.

All new skirting duct shall be of ECD manufacture.

7.4.7 Labelling

All label printing shall be machine generated permanently engraved Traffolyte labels. Adhesive labels (Brother/Dynamo type) or free handwritten labels are not acceptable.

The labelling system shall include but not be limited to:

- Provide labels including control and circuit equipment ratings, functional units, notices for operational and maintenance personnel, incoming and outgoing circuit rating, sizes and origin of supply.
- Provide labels of each sub-main cable at each terminated end. The label shall designate cable destination or switchboard origin as well as the size and type of cable installed (see example picture).



7.5 POWER FACTOR CORRECTION

7.5.1 General Requirements

Provide Power Factor Correction (PFC) unit to maintain Power Factor at or above 0.95 to all building MSB's for the buildings which they serve.

All PFC units shall be provided with de-tuning reactors to avoid damage caused by harmonics.

The PFC Unit design criteria shall be as follows:

- Nominal Operator Voltage: 400V-415V, three phase
- Rated insulation Voltage: 690V

- Nominal Operating Frequency: 50Hz
- Network Pollution Level: < 15% at 400V-415V
- Capacitance Tolerance: -5% to 10%
- Power Frequency Withstand Voltage: 2.5kV, 50Hz, 1 minute
- Operating Temperature: -5° to +60°C

PFC units shall have the following:

- Be provided with a minimum of two (2) muffin type axial fans (operating on mains power) per PFC unit cubicle to maintain temperatures to manufacturers requirements. Fans to be provided with removable and washable filters.
- A reactive power controller to control the automatic switching of each capacitor step to achieve the desired power factor. The controller shall have the following features:
 - Minimum of 6 steps
 - Manual on/off control for capacitors.
 - Multi-function display indicating stages activated, actual power factor, reactive current, active current and apparent current.
 - Built in alarm indicator of faults including over current, equipment failure, incorrect power factor, harmonics.
 - Built in alarm indicator for over temperature, fan failure.
 - Balanced cyclic use of capacitor steps to ensure uniform usage.
 - Front panel mounted, and accessible without door removal.
- Inductors to be mounted in a separate cubicle to the capacitors, fuses and switchgear
- Capacitors to be spaced a minimum of 50mm to allow for airflow between capacitors.

PFC's shall be provided with a High-Level Interface (HLI) to the University BAS. The HLI shall provide information on the system PF, report system operating temperatures and faults.

7.6 ACTIVE HARMONIC FILTERS (AHF)

7.6.1 General Requirements

All MSB's shall be provided with provisions of connection of an Active Harmonic Filter.

AHF's must be provided to the limit the total harmonic distortion (voltage and current) in accordance with the Victorian Electricity Distribution Code and to Supply Authority's requirements.

AHF unit shall be installed and located in a manner that does not affect the ventilation requirements of the unit. As a minimum, AHF shall be installed with 300mm on either side of the enclosure, 300mm from the ceiling to the top of the enclosure and 1,000mm in front of the enclosure.

AHF's shall be provided with a High-Level Interface (HLI) to the University BAS. The HLI shall provide information on mains and load side harmonics on all odd harmonics up to the 15th harmonic on both the voltage and current. The HLI shall also report system operating temperatures and faults.

7.7 METERING

7.7.1 General Requirements

Meter selection shall be based on the following table;

Service	Meter Selection
Incoming supply (i.e. MSB)	EDMI Mk10A 400V AC and Type 1
Distribution Board supply*	Type 3
Light and power chassis	Type 3
Mechanical services over 200 Amps	EDMI Mk10A 400V AC and Type 2
Solar PV systems	Type 2
Tenancy supplies	EDMI Mk10A 400V AC and Type 3

* only require if the distribution board does not have separately metered lighting and power chassis.

Current Transformers (CT) shall be WF Energy Control Manufacture, Extended Range type with accordance in accordance with AS 60044.1 Class 0.5S. CT's shall be provided with removal test links.

7.7.2 Multi-Function Meters Parameters

All multifunction meters listing in the previous section shall be of either NHP or Schneider manufacture.

Meter Type-1:

- Class 0.2S accuracy.
- Suitable for Large Scale Generator certificates.
- Approved by Clean Energy Regulator.
- Total Harmonic Distortion up to 32 harmonics.
- Harmonics analyser up to 128th harmonic.
- 10ms samples.
- Communication over IP. (Note University has multiple BAS systems and Microgrid innovative technology in place that require TCP Modbus, RS232 and RS-485 communication protocol, metering platform shall be capable of open protocol type).
- Communications Ports Ethernet and 2 x RJ45.
- Data logging capable of storing for at least 120 days.
- Measurement variables shall be as follows:
 - Disturbance Direction Detection for transient flickers, sag/swell, harmonics etc.
 - Voltage - L-N Avg, L-L A-B, L-L B-C, L-L C-A
 - Current - A, B, C, N, Current Avg
 - Power – kW Total, kVA Total and kVAr Total
 - Demand - Real Power Total, Apparent Power Total, Reactive Power Total (if available)
 - Energy - Reactive Energy into the Load, Reactive Energy out of the Load, Apparent Energy out of the Load (If available)
 - Power Factor - PF A, PF B, PF C
 - Frequency
 - Harmonic Distortion – THD Current A, B, C, N and THD Voltage A-N, B-N, C-N (if available), THD Voltage LL, Total
 - Demand Distortion

Meter Type-2:

- Class 0.2S accuracy.

- Panel mount.
- Suitable for Large Scale Generator certificates.
- Approved by Clean Energy Regulator.
- Total Harmonic Distortion up to 11th harmonics.
- Harmonics analyser up to 32nd harmonic.
- 32 samples/cycle.
- Communication over IP. (Note University has multiple BAS systems and Microgrid innovative technology in place that require TCP Modbus, RS232 and RS-485 communication protocol, metering platform shall be capable of open protocol type).
- Communications Ports Ethernet and dual RJ45.
- Data logging capable of storing for at least 90 days.
- Measurement variables shall be as follows:
 - Voltage - L-N Avg, L-L A-B, L-L B-C, L-L C-A
 - Current - A, B, C, N, Current Avg
 - Power – kW Total, kVA Total and kVAr Total
 - Demand - Real Power Total, Apparent Power Total, Reactive Power Total (if available)
 - Energy - Reactive Energy into the Load, Reactive Energy out of the Load, Apparent Energy out of the Load (If available)
 - Power Factor - PF A, PF B, PF C
 - Frequency
 - Harmonic Distortion – THD Current A, B, C, N and THD Voltage A-N, B-N, C-N (if available), THD Voltage LL, Total
 - Demand Distortion

Meter Type-3:

- Class 0.5S accuracy.
- Panel or DIN mount.
- Total Harmonic Distortion up to 11th harmonics.
- Communications Ports Ethernet or RS-485.
- Data logging capable of storing for at least 30 days.
- Measurement variables shall be as follows:
 - Voltage - L-N Avg, L-L A-B, L-L B-C, L-L C-A
 - Current - A, B, C, N, Current Avg
 - Power – kW Total, kVA Total and kVAr Total
 - Demand - Real Power Total, Apparent Power Total, Reactive Power Total (if available)
 - Energy - Reactive Energy into the Load, Reactive Energy out of the Load, Apparent Energy out of the Load (If available)
 - Power Factor - PF A, PF B, PF C
 - Frequency
 - Harmonic Distortion – THD Current A, B, C, N and THD Voltage A-N, B-N, C-N (if available), THD Voltage LL, Total
 - Demand Distortion

7.7.3 Supply Metering

Metering shall be provided at each building to allow the monitoring of the total energy use of a building. Building meters shall be of EDM1 manufacture (model number: Mk10A 400V AC) and shall be connected to the University Clariti system.

A Single Line Diagram (SLD) shall be provided to the Manager Engineering and Infrastructure for approval of the proposed metering arrangement.

In addition to the above, multi-function metering shall be provided at the switchboard level to monitor separately the lighting and power chassis, lifts etc. in accordance with the requirements of the NCC. These meters shall not be connected to the Clariti system, however connection provisions shall be provided for connection to the BAS.

All Current Transformers (CT) must be provided with removal test links.

7.7.4 Network Monitoring

All EDMI meters shall be connected to the University Clariti energy monitoring system.

All new multi-function meters shall be connected to the University BAS system via an appropriate LON based gateway router using ethernet cabling. Any devices communicating over the University network shall only communicate via LON. All new metering must connect to the University BAS via a dedicated gateway router.

Gateway routers shall be capable of storing at least 5 years of data at 15 minute intervals. Data shall be exported to an open SQL University database which must be easily retrievable via system interrogation.

Devices (meters) shall be named by the Manager Engineering and Infrastructure during the commissioning process. Allow to provide a list of all devices which shall be connected to the network monitoring system.

A metering topology schematic shall be provided to the Manager Engineering and Infrastructure for approval during the design phase

7.8 ACCESSORIES AND EQUIPMENT

7.8.1 General Requirements

All light switches, general power outlets, isolators etc. shall be of Clipsal or HPM/Legrand manufacture.

All mechanisms shall be of heavy duty type suitable for inductive loads and of Clipsal 30 USM manufacture (or HPM/Legrand equivalent). Mechanisms shall be mounted to accessory plates of Clipsal Classic C2000 series, HPM Standard series or Legrand Excel Life series manufacture and to be high impact polycarbonate.

Weatherproof switches shall be of Clipsal 56 Series (or HPM/Legrand equivalent) manufacture with locking provisions. Switches shall be UV stabilised where installed in external areas.

Chemical resistant switches shall be of Clipsal 56 Series (or HPM/Legrand equivalent) manufacture.

The following colour scheme shall be used for power outlets and lighting switches;

- Mains power White
- Generator power Red
- UPS power Green

Cleaners outlets in Patient areas to be in accordance with AS3003.

7.8.2 Lighting Switches

Light switches to be 15A rated and of Clipsal Classic C2000 series, HPM Standard series or Legrand Excel Life series manufacture.

Cable reticulation to light switches shall be via the existing wall cavity, surface mounted conduit is not permitted.

Light switches installed on fire rated walls shall be installed within a fire rated wall box to maintain the fire rating integrity of the surface

Label each light switch with the switchboard name and circuit breaker serving the switch with Traffolyte labelling. Dymo/Brother labelling will not be accepted.

7.8.3 Isolating Switches

All isolating switches shall have a minimum rating of 400V 20A, or to exceed the connected load (whichever is larger). Isolators shall be IP56 minimum in accordance with AS3000.

Where isolators are nominated as weatherproof they shall be of Clipsal 56 Series manufacture (or HMP/Legrand equivalent) with high impact polycarbonate casing and locking provisions (in ON and OFF positions).

Label each isolating switch with the switchboard name and circuit breaker serving the isolator and the item of plant served with Traffolyte labelling. Dymo/Brother labelling will not be accepted.

7.8.4 Switched Socket Outlets (SSO)

All SSO's shall have a minimum rating of 230V 10A. Mount to accessory plates of Clipsal C2000 series (or NHP equivalent) and to be high impact polycarbonate.

GPO's at workstations and hot desks shall be provided with Clipsal 30 Series USB Charger Mech (or NHP equivalent) USB outlets for mobile phone charging and the like.

Where SSO's are located on fire rated walls, they shall be installed within a with fire rated box to maintain the integrity of the wall. SSO's shall be typically mounted at a minimum of 300mm AFFL unless otherwise specified by the architect. SSO's shall be installed no closer than 500mm to any internal corner in accordance with DDA requirements.

Captive screw type outlets shall be Clipsal 56 Series (or HMP/Legrand equivalent) and to be provided for ultra-cold freezers. For regular fridges and freezers, Clipsal 10PL (or similar) shall be provided.

Label each outlet with the switchboard name and circuit breaker serving the outlet using Traffolyte labelling. Dymo or Brother type labelling will not be accepted.

Outlet quantities

Power outlet quantities shall be as follows;

- | | |
|------------------------------|------------------------------------|
| • Office workstation | Two (2) double GPO's |
| • Hot desk | Two (2) double GPO's |
| • Printer | One (1) double GPO |
| • Toilet hand dryer | One (1) GPO |
| • Corridors (cleaners) | One (1) GPO every 15m |
| • Open plan areas (cleaners) | One (1) GPO ever 100m ² |

7.8.5 Emergency Power Off (EPO)

EPO's shall be of Clipsal 56PDS1LE Series manufacture. EPO's to be mushroom push button with turn to reset functionality. EPO's shall utilise shunt trip circuit breakers for circuit protection. Allow to install EPO's a minimum of 400mm clear of any other switches, outlets and other controls mechanisms.

EPO button must be interlocked with Emergency Gas shutoff solenoids to isolate and gases when the EPO has been activated.

Provide clear label stating that the EPO must only be reset by a registered electrician.

7.9 LIGHTING

7.9.1 General Requirements

Internal lighting shall be in accordance with the requirements of AS/NZ 1680, the requirements of the NCC and the relevant Green Star Design and As-Built Credit 11.1 requirements.

In general, lighting shall have an installed light power density at least 30% below the maximum requirements of the Section J of the NCC whilst accommodating the requirements of AS/NZ 1680. External lighting shall have a light source efficacy at least 30% better than the minimum required by Section J of the NCC.

The consultant shall submit the Section J calculations / report for review to validate the power density achieves the 30% improved performance.

All new lighting shall be LED technology. Light fittings installed in enclosed offices, open plan offices, teaching spaces, auditoriums, lecture theatres, meeting rooms, boardrooms etc. shall be provided with DALI dimmable control gear as standard. Fluorescent and discharge lamp technologies are not permitted unless approved by the Manager Engineering and Infrastructure via the Modification Request Form process.

LED diodes within a fitting and throughout the installation must be from the same grouping bin such that colour variations between diodes and fittings is not noticeable. LED batch bin numbers shall be provided as part of the project O & M manual submission. LED diodes shall be of Philips, Osram, Xicato, Luxeon or Cree manufacture.

3500K lamp colour temperature shall be provided in lecture theatres, 4000K to be used in all other areas.

The minimum permissible Colour Rendering Index (CRI) shall be 80.

Lighting shall be designed and installed to achieve maximum efficiency, maintainability and controlled by suitable control systems.

In general, all lighting system products shall;

- Comply with the relevant Australian Standards and have relevant current compliance certifications to quality management systems, standards and codes.
- Be readily available in large volumes with no greater than 8-week lead times.
- Long-standing Australian luminaires suppliers shall be given preference.
- Be provided with minimum 5 years warranty.

Luminaires shall be installed in readily accessible areas. Locations of luminaires shall avoid the use of scissor lifts, scaffolding and access via crawl spaces for maintenance and replacement purposes. Some examples may be the use of wall lights in high ceiling stair wells etc.

Areas where luminaires are suspended with wire suspension, the contractor shall provide provisions to the wire suspension system such that if a single wire fails, the luminaire remains in its original suspended arrangement.

Application of Green Star credits

The Green Star credits referred to in this section apply, at a minimum, to new buildings and major building refurbishments.

7.9.2 Lighting Calculations

When undertaking lighting calculations on computer-based software, a maintenance factor of no greater than 0.7 shall be used unless otherwise required by Greenstar. Having dimmable control gear will allow for the lights to be dimmed down (during commissioning) to the required lux levels (as per AS/NZS 1680) and to be dimmed up once the luminaire light levels depreciate.

7.9.3 Switching

Light switches shall generally be located at the entry to each space. Switches shall not be installed external to the space it is serving with the exception of chemical and hazardous materials storage spaces. Only light switches shall be provided to substations, switch rooms, plant rooms, Comms rooms, and services risers i.e. occupancy detection is not permitted in these areas.

Light switches shall be installed in series with occupancy sensors where both switching methods exist i.e. the light switch shall control the luminaires and occupancy sensors on the circuit. The default setting for the occupancy sensors shall be 30 minutes.

The table below provides direction on the types of areas and their required switching arrangements;

Open office areas	Manual switching installed in series with occupancy sensor with switching zones no greater than 100m ²
Enclosed office areas	Manual switching installed in series with occupancy detection
Lecture theatres	Dynalite LCS
Teaching spaces	Manual switching installed in series with occupancy detection
Boardrooms/Conference rooms	Manual switching installed in series with occupancy detection with separate switching zones for presentation mode i.e. projector screen lighting circuits to be switched separate to the remaining fittings.
Corridors	Time clock with occupancy detection for afterhours operation
Publicly accessible areas	Time clock with occupancy detection for afterhours operation
Computer labs	Time clock with occupancy detection for afterhours operation
Entry lobbies	Time clock with occupancy detection for afterhours operation
Plant rooms	Manual wall switching
Service Risers	Manual wall switching
Laboratories	Manual wall switching

Toilets	Manual switching installed in series with occupancy detection
External lighting	Time clock control with manual override located at the switchboard

Perimeter lighting zones shall be provided with photoelectric sensors control to automatically dim fittings down when the natural light exceeds 340 lux at desk height.

Corridors and lobbies shall be provided with 24-hour lighting. Allow to provide one (1) 24-hour light every 15m in corridors and every 100m² in lobbies.

Switches shall be installed between 900mm to 1000mm AFFL and shall comply with DDA requirements i.e. no closer than 500mm from any corner spaces.

7.9.4 Occupancy Detection and Photoelectric Sensors

Where occupancy sensors and photoelectric sensors are being used, they shall be of BEG manufacture. Integral occupancy photoelectric sensors may be used.

The occupancy sensors shall have timer adjustment setting from 1 minute up to 30 minutes.

7.9.5 Lighting Control System

All new and refurbished lecture theatres and auditoriums shall be provided with a Dynalite Lighting Control Systems (LCS) to control lighting. In new buildings, the Base building lighting shall also be controlled by a Dynalite LCS.

The new Dynalite equipment shall be DIN rail mounted in the supplying switchboard. The system shall be provided with following minimum features:

- Dynalite Universal Controller
- Dynalite Antumbra Dynet Communications module
- Dynalite PDEB AV ethernet interface with socket plate
- Dynalite Antumbra lighting control panel
- Dynalite PDEG headend ethernet interface (for headend integration)

The new Dynalite LCS shall be interfaced to the AMX AV control system where installed.

All new Dynalite LCS's shall connect to the University Dynalite System Manager software. New instances of the System Manager software shall not be provided. The project shall allow to modify the existing System Manager to include the new building/spaces onto the System Manager software.

All external lighting shall be controlled via PE cell and time clock control, with manual override located at the switchboard supplying the external lighting circuit

7.9.6 Control Gear

Electronic control gear shall be provided for all luminaires and shall be of Tridonic Atco, Philips or Osram manufacture and include the following features as a minimum:

- Flicker free - constant current LED driver (minimum 12-bit)
- Constant light output, output to be independent of fluctuating supply voltage
- Voltage protection (i.e. protection against under and over voltage)
- Other Features
 - Operating frequency ≥ 40 kHz
 - Earth leakage current ≤ 0.5 mA.

- Operating temperature range from -25°C to +50°C
- For luminaires with or in accordance with EN 60598
- Thermal protection according to AS/NZS 61347.1
- EMC compliance according AS/NZS CISPR Set

Drivers must meet harmonic requirements outlined in AS/NZS 61000.3.2.

LED Drivers – DALI

Digital Addressable Lighting Interface (DALI) drivers shall be provided as required by the project. The driver shall be of Tridonic Atco, Philips or Osram manufacture.

The selected driver shall match the performance characteristics of the conventional electronic driver, and shall incorporate the following additional characteristics:-

- All DALI control gear shall be capable of lamp monitoring.
- All DALI control gear shall be of the same manufacture, generation and have compatible firmware installed.

7.9.7 External Lighting General Requirements

External lighting shall be designed in a manner to avoid upward light pollution and to be in accordance with the requirements of AS1158 and AS4282. In some instances, up lighting may be considered to enhance the aesthetics of a building, final approval shall be provided by the Manager Engineering and Infrastructure. Under no circumstances shall lighting be directed into the night sky.

The AS/NZ 1158 lighting category shall be selected by the Manager Engineering and Infrastructure.

External lighting shall be provided to all internal roads, walk ways and pathways to provide a safe environment for pedestrians.

In general, external lighting shall be via pole top or wall mounted luminaires and shall have the following minimum specifications;

- Marine grade, die cast aluminium body.
- IK07 impact protection.
- IP66 ingress protection.
- Corrosion protection.
- Provided with integral circuit breakers with removable panels (for pole tops).

An external lighting masterplan design has been undertaken for the Parkville campus and is available on the Design Standards web page. This masterplan must be used for all external grounds lighting installations. Any changes to the masterplan design must be approved by the Manager Engineering and Infrastructure via the Modification Request Form process.

Bollard luminaires will not be accepted.

Switching and control

All external lighting shall be controlled via time clock control, with manual override located at the switchboard supplying the external lighting circuit. PE sensors shall only be installed with approval from the Manager Engineering and Infrastructure via the Modification Request Form process.

7.10 EXIT AND EMERGENCY LIGHTING

7.10.1 General Requirements

An exit and emergency lighting system shall be installed in accordance with the requirements of the NCC and AS/NZS 2293.

The University utilises wired and wireless technology computer-based monitoring system of Legrand Axiom manufacture in all new buildings across all campuses.

7.10.2 System Description

The system comprises of the following equipment;

- Exit and emergency luminaires
- Wireless Area Controllers (WAC)

Exit and emergency luminaires shall be located in accordance with the spacing requirements of AS/NZS 2293, WAC's shall be located after a site survey has been undertaken to determine the best position for maximum coverage. In general, WAC's shall be located in electrical cupboards away from public view. Connection from the WAC to the luminaires shall be via cable connection. In the instance where this is not possible, wireless connectivity between the WAC and luminaire is acceptable.

The system shall be complete with all necessary equipment and components for a fully operational network and with data connectivity. The electrical contractor installing the system shall coordinate the works with Legrand for commissioning and sign-off prior practical completion.

7.10.3 Exit and Emergency Luminaires

Exit and emergency luminaire shall be supplied complete with RF antenna. All new exit and emergency luminaires shall meet the following minimum specification:

- Comply with AS/NZS 2293.
- Be marked and labeled in accordance with AS/NZS 2293.
- Be supplied with Lithium Iron Phosphate batteries. Each battery pack to be marked with the date of manufacture.
- Have incorporated iSmart temperature control for Lithium Iron Phosphate batteries.
- Be supplied with a LED to indicate network communications.
- To be independent and fail safe in the event of a network system failure.
- Be tested in accordance with AS/NZS 2293.
- Each exit and emergency luminaire shall be installed per AS/NZS 2293 and the Building Code of Australia and have a directional arrow as appropriate.
- Satellite emergency luminaires shall be either standard circular or corridor lighting distributions.

7.10.4 System Graphics

Each project shall make allowance to upload the new locations of the exit emergency luminaires onto the University of Melbourne online building floorplan database (SISfm). This is to be organised through Engineering and Infrastructure and Space Management.

7.11 STANDBY POWER SYSTEMS

7.11.1 General Requirements

Standby power supply systems are generally not considered unless specifically required by statutory regulations for life safety or as required due to special requirements of a project. Approval for the requirement of a standby power supply system shall be sought from the Manager Engineering and Infrastructure early in the design process.

7.11.2 Standby Generator

When required, direct injection standby diesel generators shall be installed within a sound attenuated enclosure to achieve no louder than 75 dBA (minimum) measured at 1m from the enclosure. The generator set rating shall be Standby rated and to be sized to 30% above the calculated maximum demand.

Automatic transfer switches shall be provided for the connection from the generator to the MSB. MSB's supplied by standby generators shall be provided with motorised breakers (for outgoing circuits) with PLC control for load shedding and connection to the University BAS.

The generator set output switchboard and control panel shall also be connected to the BAS for system monitoring.

The generator set shall be provided with a brushless, self-regulating alternator rated to provide an overload capacity of 10% for 1 hour and up to 50% for 2 minutes without causing damage to the generator.

Fuel sources and storage

Standby generators shall be diesel type and provided with internal double skinned tanks achieving no less than 24 hours of runtime at full load. If external tanks are required for additional run time, they shall be self-bunded, double skinned type. Flow and return pumps shall be provided to pump fuel from the tank to the generator set. Fault alarms shall be sent to the BAS to indicate pump failure.

Remote refuelling points shall be provided with an indicator panel showing overflow alarm and a fuel tank level indicator. A connection to the BAS is required to provide information of the fuel level in the tank.

Battery and charger

Provide a generator set starting battery of heavy duty sealed lead-acid type, suitable to start the generator set continuously for 30 seconds initially, and for a further similar period after 2 minutes.

The battery charger shall be connected to mains power supply and shall be constant potential type with integrated current protection.

Alarms

Provide for alarms from the generator to be connected to the University's BAS system. Confirm the communications protocol to allow for a high level interface with the BAS system.

7.11.3 Uninterruptable Power Supply (UPS)

UPS's shall not be provided to supply base building loads. Please refer to the University's CANAS standard for UPS required for I.T. and Communications systems.

7.12 PHOTOVOLTAIC (PV) SYSTEMS

7.12.1 General Requirements

In general, the PV system shall be in accordance with the relevant Australian Standards, the requirements of the Victorian Service and Installation Rules (SIR's) and the requirements of the local electrical Supply Authority.

The purpose of this section is to cover the requirements and recommendations of grid connected PV systems, including systems with battery storage capabilities. Selection and provision of system equipment, pre-installation requirements, post installation requirements shall be in accordance with this section, and deviations to the requirements of this section must be approved by the Manager Engineering and Infrastructure.

7.12.2 System Delivery

A complete turnkey PV system shall be provided by the system Provider (system designer, installer and commissioner). The Provider shall design, supply, install and commission the PV system and all necessary ancillary works to provide a fully operational system.

When delivering a grid-connected PV system, the system Provider is required to undertake all works in accordance with the manufacturers requirements, the University of Melbourne Design Standards, and make all necessary applications to the local electricity Supply Authority. In addition to the above, the Provider shall be fully accredited by the Clean Energy Council (CEC) of Australia. Any LV electrical work must be undertaken by a licensed electrical contractor.

7.12.3 Site Assessment

A complete site assessment needs undertaken prior to the installation of a PV system. The site assessment shall allow for the following as a minimum;

- Solar access and resource (roof orientation and pitch, shading etc.)
- Available roof space for the PV panels.
- Establishment of inverters and batteries.
- Structural integrity of the roof to accommodate the weight and wind loading
- Effect of the proposed system on other Services
- Access requirement for initial installation and ongoing maintenance.
- Review and upgrade (as required) of existing electrical systems which are directly connect to the PV system.
- Voltage rise assessment.

7.12.4 Roof Access

A permanent safe roof access system shall be provided for future access to all parts of the PV system.

Where strings of panels are installed adjacent each other, the array must be installed in a manner which only requires the removal of one (1) panel in order to gain access to a panel in the array.

7.12.5 System Design

The system design shall be in accordance with the requirements of the CEC Grid Connected Solar PV System – Design Guidelines for Accredited Installers.

To avoid systems losses, DC quasi-currents and circulating currents, system strings connected in parallel to a common inverter must have less than 5% voltage mismatch and have similar rated electrical ratings.

A system single line diagram must be provided to the Manager Engineering and Infrastructure for approval.

7.12.6 Mounting and Location

In general, the mounting system shall be in accordance with AS/NZS 1170 and must include engineering certification.

The location of the PV system shall be such that the system yields maximum annual solar generation.

Flat mounted systems shall only be installed on roofs with a minimum gradient of 10 degrees to the horizontal and shall be installed on north facing roofs.

Rake mounted system shall be installed on an incline with the same angle as the angle of latitude of the site $\pm 10^\circ$.

Systems may be installation on east/west facing roofs if a north facing roof is not available provided the system yield meets the requirements of Section 7.12.7. Final approval must be provided by the Manager Engineering and Infrastructure.

Inverters shall be located in plant room or restricted access areas. In general, they must be located away from excessive heat, moisture, dust and direct sunlight. They should also be located such that DC and AC losses are reduced.

7.12.7 System Rating and Capacity

For systems offsetting the building electrical usage, the system capacity rating shall be sized in accordance with the building energy usage (obtained from Clariti) and existing power bills (available from Engineering and Infrastructure). For new buildings, the PV system shall be sized based on the anticipated building load profile. System capacity rating and payback calculation shall be provided to the Manager Engineering and Infrastructure for approval.

7.12.8 Supply Authority Approval

The system Provider shall be responsible for applying for and obtaining approval from the electrical Supply Authority for the connection of the new PV system. This also includes for coordination and liaison with the electrical Supply Authority until a grid connection agreement has been received from the electrical Supply Authority. Allowance shall be made to pay all associated fees and charges as required for the approval process.

7.12.9 Equipment Requirements

Photovoltaic Modules

PV modules used in a single installation shall be of the same manufacture.

In general, all PV modules used in an installation must comply with AS/NZS 5033, be certified to IEC-61215, IEC-61646 IEC-61730 and be listed in the Clean Energy Council approved PV module list.

PV modules must be Class A also be certified as meeting Fire Safety Class C or better per UL 790.

PV modules installed in agricultural areas shall be certified to IEC-62716 (ammonia corrosion testing of PV modules).

The minimum PV module efficiency shall be no less than 14% for poly-crystalline modules, no less than 15% for monocrystalline modules and no less than 9% for thin film PV modules. Roof mounted modules shall have an effective operating temperature

range of between -20°C to +80 °C with a maximum allowance temperature coefficient of 0.5%/ °C.

Inverters

In general, 3 phase inverters shall be used, however micro-inverters may also be used as required. In the case that micro-inverters are used, AC isolators must be provided for each array grouping. AC isolation requirements to be in accordance with the requirements of the local electrical Supply Authority.

Inverters must comply with the requirements of AS/NZS 4777 and AS/NZS 5033.

Inverter specifications must comply with the over/under voltage requirements of the local electrical Supply Authority and the Victorian SIR's and have the following minimum requirements;

- Total harmonic distortion of the output current (THDC) to be no greater than 5% (applicable to all harmonics)
- Auto-synchronization capability with the LV network
- +10%/-6% voltage regulation
- Passive and active anti-islanding protection
- Voltage protection, frequency protection and transient voltage limitation
- Earth fault detection and alarm
- Include the capability to be coupled with a battery storage system

Multiphase systems shall be balanced in accordance with the requirements of the local electrical Supply Authority. Network protection shall be provided to isolate the system when voltage imbalances exceed 2%.

DC Cables and Equipment

In general, all DC cabling and system equipment shall be in accordance with the requirements of AS/NZS 5033. DC cabling shall be installed in a separate conduit/cable tray to AC cabling.

7.12.10 System Voltage Drop/Rise

The DC voltage drop from the inverter to the final PV module shall not exceed 3%.

The AC voltage rise between the inverter and the MSB and the MSB to the point of supply shall be no greater than 1%

7.12.11 Earthing and Lightning Protection

The entire system (DC and AC) shall be earthed in accordance with requirements of AS/NZS 3000 and AS/NZS 5033.

DC surge protection shall be installed at the DC side of the system and shall be provided for each inverter.

The PV system wiring shall be installed in accordance with the recommendation of AS/NZS 5033 to reduce the magnitude of over voltages caused by lightning strikes.

7.12.12 Warranty Periods

The following warranty requirements shall apply;

- Inverter and PV module manufacturer's warranty shall be no less than 10 years.
- Manufacturer's power warranty shall be no less than 10 years at 90% output and 25 years at 80% output
- Mounting systems shall be provided with 5-year workmanship warranty and 10-year equipment warranty

In general, the system equipment shall be of the same manufacturer as to not void system warranty.

7.13 TESTING, COMMISSIONING AND OPERATIONAL MAINTENANCE

7.13.1 General Requirements

Testing, commissioning and the submission of detailed Operational & Maintenance Manuals (O&M) shall be provided for all projects. Draft soft copies shall be submitted by the contractor to the Engineer/Consultant for review prior to the submission of the final to the Manager Engineering and Infrastructure.

A list of all systems which are being tested and commissioned shall be provided to the Manager Engineering and Infrastructure for review and approval.

Qualified technicians shall undertake testing and commissioning as may be necessary to satisfy the Independent Commissioning Agent (ICA) and the University and that the installation meets the requirements of this Design Standard. All test instruments/equipment are to be calibrated at an approved N.A.T.A. certified laboratory prior to carrying out the tests. ICA's shall be used for all new build projects subject to final approval by the Manager Engineering and Infrastructure, this is also in-line with Green Star Design and As-Built Credit 2.4. Refer to Section 3: Sustainable Design for details of the minimum requirements for Green Star points.

In accordance with Green Star Design and As-Built Credit 2.1, a services and maintainability review shall be undertaken during the design phase of the project. The review shall facilitate input from the University and shall address the following;

- Commissionability
- Controllability
- Maintainability
- Operability, including fitness for purpose
- Safety

Refer to Section 3: Sustainable Design for details of the minimum requirements for Green Star points

Application of Green Star credits

The Green Star credits referred to in this section apply, at a minimum, to new buildings and major building refurbishments.

7.13.2 Testing and Commissioning

Testing and commissioning of all installed electrical systems shall be in accordance with the relevant regulatory requirements and the specific manufacturers requirements.

Sufficient notice shall be provided for all testing and commissioning such that Engineering and Infrastructure can be present as required.

In addition to the Consultants/Engineers requirements for systems testing and commissioning, the following systems shall also be tested and commissioned;

- Phase rotation
- Cable insulation resistance.
- Correct tightness of screwed and bolted connections.
- Circuit protection including operation and discrimination of RCD's, MCCB's, MCB's and ACB's etc.

- Balancing of loads, ensure no greater than 20% imbalance across the active phases.
- Check and verify operation, calibration and correct output of all meters. Provide calibration certificate and test results.
- Connection and operation of new meters to Clariti and University network data monitoring system.
- Correct operation of lighting control systems, and lighting control mechanisms.
- Generator startup, and correct operation under full load.
- Power Factor Correction unit
- Active Harmonic Filter unit

The electrical contractor shall submit all completed ITCs / ITPs for all the systems to be commissioned prior to any witness testing being undertaken. This provides the Consultant / Engineer the ability to review results and provide any commentary prior to the final witnessing / signoff of the system/s.

Provide all testing and commissioning data to the University in a report format which shall also be included in the O&M manuals.

In accordance with Green Star Design and As-Built Credit 2.2, pre-commissioning and commissioning shall be undertaken in accordance with the Green Star Credit requirements. A Commissioning Specification and Commissioning Plan shall be provided.

Refer to Section 3: Sustainable Design for details of the minimum requirements for Green Star points.

7.13.3 Building System Tuning

In accordance with Green Star Design and As-Built Credit 2.3, tuning and adjustments of all building systems is to be provided on a quarterly basis for a period of 12 months from date of Practical Completion.

The objectives of the building tuning process are as follows:-

- Verify that systems are performing to their design potential during all full and part load conditions;
- Reviews of environmental performance against the environment targets;
- Collection of user feedback to match the system performance with the occupant's needs;
- Adjustment of all the systems to account for all deficiencies discovered;

A building tuning report shall be provided which reports the outcomes of the quarterly turning process.

Refer to Section 3: Sustainable Design for details of the minimum requirements for Green Star points.

7.13.4 Samples, Technical Data Sheets and Shop Drawings

Under certain circumstances, the University may request samples, technical data sheets and shop drawings to be submitted for review and approval. As a minimum, the following are required to be reviewed;

Samples;

- Luminaires
- Lighting control panel (for Dynalite systems)

Data sheets;

- Floor boxes
- Generator sets
- Diesel fuel tanks
- Pumps (diesel)
- Cable pits
- PV system

Shop drawings;

- Main Switchboards
- Distribution boards above 250 Amps
- Generator set, acoustic enclosure, fuel storage tanks and generator switchboards
- Single line diagrams
- Busduct systems
- Trenching routes
- PV system and AC/DC switchboards
- Power Factor Correction units
- Active Harmonic Filter units

7.13.5 Operational Maintenance and Operation & Maintenance Manuals (O&M)

The design consultant must ensure that the project documentation includes a requirement that all installations are provided with a 12-month defect liability period from the date of practical completion. PV systems shall be provided with a 5-year maintenance period.

During the defect liability period, electrical contractors shall allow for the following services;

- Undertake monthly inspections and provide maintenance repair works.
- Undertake periodic testing of Lighting Control Systems to ensure correct operation
- Check installed switchboards
- Provide bi-annual testing of the generator system

Monthly maintenance reports shall be provided for the University's records and information.

Provide O&M manuals at practical completion consisting of:

- Operational & Maintenance manuals and instructions
- Maintenance reports
- Testing and commissioning reports
- Measuring and testing equipment calibration certificates
- Product manufacture data sheets (specifics only, entire product catalogs will not be accepted)
- Schematic diagrams and single line diagrams
- Switchboard as-built shop drawings
- Switchboard schedules
- Discrimination studies and circuit breaker settings
- As-installed drawings
- System operation descriptions
- Product warranty certificates

- Copies of all test and approval certificates
- Details of the grid connection agreement (for PV systems)
- Renewable Energy Certificates agreement (either STC or LGC registration details)
- Thermographic scan results
- Registrations (as applicable) in the name of the University of Melbourne

For PV systems, one set of manuals shall be stored in a weatherproof clear document holder that is fixed to the wall beside the inverters.

7.13.6 Design Change Authorisation

All requests for changes to the requirements of the Design Standards must be made on the Modifications Request Form. No design work is to proceed on the basis of the proposed modification until the modification request has been approved in writing.

7.14 MATERIAL SELECTION

The Designer/Engineer shall select products from this table; proposed alternatives require approval via the Modification Request Form.

Item	Supplier	Model no.	Description	Notes
Wiring accessories	Clipsal	IP56 range	Weatherproof wiring accessories	Wet areas
Wiring accessories	Clipsal, HPM or Legrand	2000 series Standard Series Excel Life	General purpose power outlet (GPO)	Single and dual outlet
Wiring accessories	Clipsal, HPM or Legrand	2000 series Standard Series Excel Life	Light switch	Min 15A mechanism
Floor box	ECD CMS Electracom	FB4MU series V181220N1 V181220N2 98FBMUFB1 98FBMUFB2 98FBMUFB3	With rubber cable exits	
Emergency Lighting System	Legrand	Axiom		
Exit Luminaire (general)	Legrand	G2 Slide Connect	Slide Connect fitting, white body rim	
Exit Luminaire (theatres)	Legrand	G2 Slide Connect	Slide Connect fitting, green on black diffuser	
Emergency Luminaire (general)	Legrand	Satellite Axiom series		Provide surface mounted box where required

Item	Supplier	Model no.	Description	Notes
Emergency Luminaire (car parks & fire stairs)	Legrand	WP2 from Axiom series	2100 lumen option	
Emergency Luminaire (car parks)	Legrand	WP2 from Axiom series	4100 lumen option	
LED diodes	Philips, Osram, Xicato, Luxeon or Cree	To suit application		
LED drivers	Tridonic Atco, Philips or Osram	To suit application		
Lighting control system (general & theatres)	Philips Dynalite	To suit application		
Motion sensors	Dynalite BEG	To suit application		Use Dynalite sensors where Dynalite is available
Pole-Top Luminaires	WE-EF	Refer to the External Lighting Masterplan		
Pole-top luminaire pole	WE-EF Vicpole	Refer to the External Lighting Masterplan		
Miniature circuit breaker (MCB)	NHP, Schneider, Eaton Quicklag			
Control gear	Sprecher + Schuh		Contactors, relays, panel-mounted control switches	
Electronic time-switch clock	Sauter, NHP or Schneider	ZDR102-F02	Dual Channel electronic time-switch clock	

**SECTION 8: FIRE PROTECTION AND DETECTION SERVICES
CONTENTS**

8.1	INTRODUCTION	2
8.2	STANDARDS AND DESIGN CRITERIA	2
8.3	FIRE PROTECTION AND DETECTION SYSTEMS	3
8.3.1	Fire Protection Systems	3
8.3.2	Fire Detection Systems	3
8.3.3	Sound Systems for Intercom Systems for Emergency Purposes	4
8.3.4	EWIS Equipment Selection Requirements	5
8.3.5	Portable Hand Held Extinguishers	5
8.3.6	Fire Hoses	5
8.3.7	Sealing Penetrations	6
8.3.8	Fire Protection Services Deployment	6
8.4	DOCUMENTS TO BE PROVIDED	7
8.5	INDEPENDENT COMMISSIONING AGENT	7
8.6	DESIGN CHANGE AUTHORISATION	7
8.7	DEFECTS LIABILITY PERIOD	7

8.1 INTRODUCTION

This section of the Design Standards provides details of the University's minimum requirements for fire protection and detection. The consultant team is required to produce their own project specification which incorporates this section and other sections of the Design Standards as well as all relevant legislation, regulations and codes.

The consultant shall consult with the Local Fire Brigade and the University's Fire Manager (Infrastructure Services) at the earliest possible stage in the design process so that both the local fire brigade and the University's requirements are fully satisfied.

All project documentation is required to be submitted for review prior to tendering.

8.2 STANDARDS AND DESIGN CRITERIA

The design and installation is to meet all the requirements of national, state and local authorities including but not limited to the following:

- National Construction Code of Australia (NCC);
- AS 2118.1 Automatic Fire Sprinkler Systems;
- AS 2118.4 Automatic Fire Sprinkler Systems – Residential;
- AS 1670.1 Fire Detection, warning, control and intercom systems – system design, installation and commissioning – Fire;
- AS 1670.4 Fire Detection, warning, control and intercom systems – system design, installation and commissioning – Sound systems for emergency purposes;
- AS 1603 Series of Standard for Fire Alarm Equipment;
- AS1668.1 & 3 Use of Smoke Control in Buildings;
- AS 2441 Installation of Fire Hose Reels;
- AS 1850 Portable Fire Extinguishers;
- AS 2444 Portable Fire Extinguishers and Fire Blankets – Selection and Location;
- AS 3500 National Plumbing and Drainage Code;
- AS 2419 Fire Hydrant Installation System Design, Installation and Commissioning;
- AS ISO 14520 Gaseous Fire-Extinguishing Systems – Physical Properties and System Design;
- HB 233-2008: Fire Protection Systems Testing – Water Conservation Handbook;
- Plumbing Industry Commission of Victoria;
- Local Fire Brigade;
- Local Municipal Council;
- Water supply authority requirements;
- ACMA Regulations;
- Manufacturer's guidelines.

The consultant team is, at the earliest possible time, to consider in their design the provision of safe and easy access for the maintenance of all equipment.

Where existing buildings are undergoing staged refurbishment, the consultant shall consult with the relevant building surveyor and the University's Project Manager on the requirements for refurbishment works compliance.

Where the deemed to satisfy requirements of the NCC cannot be met, the consultant and relevant building surveyor shall consult with the University and Local Fire Brigade to achieve an alternate solution.

Fire protection systems shall generally utilise town mains pressure or, at the Parkville campus the campus fire ring main. Fire pump sets shall be installed where town's main water pressure does not provide adequate pressure for firefighting requirements.

This Section of the Design Standards does not cover Emergency Lighting, refer to Section 7, Electrical Services.

8.3 FIRE PROTECTION AND DETECTION SYSTEMS

8.3.1 Fire Protection Systems

Where fire protection systems are required by NCC or the University, these systems shall include the following:

- Wet pipe sprinkler system;
- Wall wetting sprinkler protection;
- Pre-action sprinkler systems;
- Gaseous suppression systems for communications and data rooms/suites;
- An appropriate automatic fire extinguishing flood system will be required for gas and cylinder storage areas.
- Fire hydrant system;
- Fire hose reel system;
- Portable fire extinguishers and fire blankets;
- Flow and pressure testing of existing system prior to design;
- Upgrade of hydrant hose couplings to local brigade requirements;
- Removal of fire hoses from existing buildings as part of refurbishment work (*Note: This will require a Building Permit to be issued by a Registered Building Surveyor*);
- Refurbishment projects shall be fully documented for all floors. When a partial floor level is being refurbished the total floor, areas shall be documented and the fire protection systems upgraded as required.
- Padlocks will be Lockwood type 225/40/119 fire red keyed to suit CL 003 keys.

8.3.2 Fire Detection Systems

The fire detection systems to be considered where a fire alarm system is required by NCC or the University shall include the following:

- An addressable point type smoke detection system;
- An aspirating smoke detection system connected to the addressable FIP;
- Connection of the FIP to the Emergency Warning and Intercom System (EWIS);
- Break glass alarms connected to the FIP;
- Networking of FIP's in University buildings and campuses;
- Provision of Mimic Panels for local information and alerts/control;
- Provision of graphic display monitors for individual University buildings and/or campus wide as requested by the University;

- Updating existing graphic display monitors where existing systems are upgraded/expanded;
- Provision smoke control system detector;
- Linking with magnetic door holders;
- The consultant shall document the use of AMPAC Fire Finder Plus Analogue Addressable Fire Indicator Panels in new buildings, renovations and building upgrade works;
- Where existing FIP's installed in existing buildings are to be fully or partially refurbished the designer shall document, for record purposes the entire fire detection system including existing system elements and those affected by the refurbishment works;
- Each addressable loop circuit shall not exceed 80% of the design capacity recommended by the manufacturer;
- A circuit isolator shall be fitted to each floor or between a maximum of 40 devices;
- Provision of both electronic and hard copies of certificates, commissioning documents and drawings. Where works involve partial upgrades to existing systems the University requires the contractor/designer to provide this information for the entire system.

The Parkville Campus, excluding the buildings below, is served by an "AMPAC Fire Finder" addressable series of fire indicating panels. The main FIP is fitted with Dual Wireless Alarm Signalling Equipment (ASE) which is monitored by ADT/Tyco. The Campus is divided and wired with four cable loops. All building FIP, main monitored valves/pressure switches and or DBA's are connected via addressable input devices and wired with four cable loops. These input devices are programmed into the main FIP via five zones on the ASE (3 for FIP's and 2 for sprinklers).

The FIP is to be fitted and programmed with a graphic package which will be remotely monitored in the security office (Grattan St) and at Campus Services (Bedford St). All new sub FIP's will be AMPAC Fire Finder Plus type panel and the building is to be fitted with addressable type detectors.

All locks cylinders shall be keyed to CL 003 locks.

Parkville buildings fitted with their own ASE are:

Bld 162	Alice Hoy
Bld 158	Sydney Myer Asia Centre
Bld 199	Arts Centre
Bld 198	1888
Bld 189	Frank Tate
Bld 171	Eastern Resource Centre
Bld 168	Doug McDonnell

All other buildings external to the main Parkville campus have their own ASE, the University's Project Manager shall advise on a case by case basis.

8.3.3 Sound Systems for Intercom Systems for Emergency Purposes

- The consultant shall document an emergency warning and intercom system compliant with the requirements of the NCC, the University and AS1670.4;

- The consultant shall investigate the possibility of integrating emergency warning with the public-address sound system dependant of the building configuration and University public address requirements;
- The consultant shall document the use of an AMPAC EV 3000 Occupant Warning and Intercom System in new buildings and where a building is being refurbished;
- The consultant shall consider the following when designing the Emergency Warning Intercom System:
 - The system shall be capable of integration into the University's existing site wide system;
 - The sound system shall incorporate voice announcements;
 - Warden Intercom Points;
 - Induction loops and visual warning devices for hearing impaired people.

8.3.4 EWIS Equipment Selection Requirements

AMPAC EV3000, is the Early Warning Intercom System approved by the University. The EV3000 model is to be used for large building projects.

The EWIS shall be interfaced to the fire indicator panel and shall activate on receipt of an alarm from the FIP or a break glass alarm (BGA).

The EWIS shall be installed to act as a standard PA system. Early discussion with the University Project Manager is required to establish zones, etc.

The EWIS shall be positioned adjacent to, or directly in the line of sight of, the building fire panel.

All lock cylinders shall be keyed to CL 003 locks.

8.3.5 Portable Hand Held Extinguishers

The consultant shall document the location of type of portable handheld fire extinguishers with the building as required by the NCC, the University, AS 2444 and AS1850.

Public access areas be extinguishers are to be housed in lockable break glass cabinets.

Special consideration shall be given to laboratories, data suites and switch rooms and Communication rooms. The consultant is to consult with the University's Project Manager and with user's groups prior to documenting the intended type of extinguisher.

Refer to Section 2: Occupational Health and Safety, for the University's requirements on the selection, location and number of portable fire extinguishers.

8.3.6 Fire Hoses

The minimum requirements for fire hoses are set out in the relevant Australian Standard. The project specification shall require fire hoses to carry a two-year warranty against defective material or faulty workmanship.

The consultant is to note that in University buildings the following arrangements have been agreed to by the local fire brigade:

- that all external hydrants need not be fitted with a fire hose, and that where this hydrant is enclosed in a cabinet, the appropriate sign will be displayed;
- that where an approved hose reel has been installed in a building, the ground floor hydrant points need not be equipped with a fire hose;

- that where hydrants are to be equipped with a fire hose, then 30 metres of 38mm hose with a branch and 12mm nozzle will be installed;
- that within a building where hydrants and hose reels are provided in accordance with regulations, that the requirement to have a 9-litre stored pressure water fire extinguisher installed per 200 square metres will not be mandatory. The consultant is to discuss this provision with the University's Fire Manager

Detailed hose requirements are as follows:

- Size: 30 metre length x 38mm diameter
- Class M: Working Pressure 1400 kPa Min
- Burst Pressure: 3500 kPa Min
- Construction: Synthetic woven jacket
- Lining: Latex Rubber, or equal and approved equivalent.
- Coupling: Supply with MFB-approved coupling.

8.3.7 Sealing Penetrations

All penetrations through fire rated walls, floors and ceilings must comply and be certified to the following:

- AS 1530.4 Fire Tests on building materials, components and structures
- AS 4072.1 Components for the fire protection of openings in fire resistant separating elements

8.3.8 Fire Protection Services Deployment

The following table outlines the University's baseline requirements regarding the deployment of Fire Protection Services. The consultant is required to agree to the intended Fire Protection Services with the University's Fire Manager prior to commencing the project design.

Requirement	Category 1	Category 2	Category 3	Category 4
Fire Protection				
Pre-action Sprinklers	Yes			
Gaseous Suppression Systems	Yes			
Sprinkler System		Yes	Yes	
Fire Hydrants	Yes	Yes	Yes	
Fire Hose Reels	Yes	Yes	Yes	
Portable Fire Extinguishers	Yes	Yes	Yes	Yes
Fire Detection				
Aspirating Smoke Detection System	Yes			
Addressable Fire Detection System		Yes	Yes	
Emergency Warning Systems				

EWIS	Yes	Yes	Yes	
Occupancy Warning System			Yes	

Building categories are defined as follows:

- Category 1 – Critical Facilities:
Data centres, archive stores etc.
- Category 2 – Important Facilities:
Major research facilities, animal houses, libraries, large residential accommodation.
- Category 3 – Standard Facilities:
Minor research facilities, teaching facilities, office accommodation, sporting facilities, residential accommodation.
- Category 4 – Minor Facilities:
Storage facilities, sheds, glass houses etc.

8.4 DOCUMENTS TO BE PROVIDED

In addition to the normal as-built drawings and specifications, manuals, warranties and certifications required to be provided to the building owner at practical completion, the following requirements are specifically drawn to the consultant's and contractor's attention:

- Independent commissioning documentation
- Fire matrix (all items connected to the FIP to be on one matrix)
- Fire penetration certificates
- Hydrant and sprinkler block plans
- A3 laminated set of fire detector drawings

Draft documents are to be provided four weeks prior to practical completion and final documents are to be provided no more than four weeks after practical completion.

8.5 INDEPENDENT COMMISSIONING AGENT

The contractor is required to appoint an independent commissioning agent to inspect and confirm compliance of the fire systems with the University's Design Standards and all relevant Australian Standards.

The commissioning agent's appointment will be subject to approval by the University's Fire Manager.

8.6 DESIGN CHANGE AUTHORISATION

All requests of changes to the requirements of the Design Standards must be made on the Modification Request Form. No design work is to proceed on the basis of the proposed modification until the modification request has been approved in writing.

8.7 DEFECTS LIABILITY PERIOD

The design consultant MUST include in the project documentation a requirement that as part of his contact, the fire services contractor is to provide a full maintenance programme (regulatory, programmed, breakdown etc) during the 12 months defects liability period. The contractor must provide monthly reports, work docket etc to the University's Fire Co-Ordinator.

SECTION 9: MECHANICAL SERVICES CONTENTS

9.1	GENERAL	3
9.1.1	Design Principles	3
9.1.2	Heritage Requirements	4
9.1.3	Standards and Regulatory Requirements	4
9.1.4	Design Change Authorization	5
9.2	DESIGN BRIEF	5
9.3	GENERAL DESIGN CRITERIA	6
9.3.1	Ambient Conditions	6
9.3.2	Internal Design Criteria	6
9.3.3	Occupancy	6
9.3.4	Ventilation Rates	6
9.3.5	Filtration	6
9.3.6	Noise and Vibration	6
9.3.7	System Efficiencies	7
9.3.8	Refrigerants	8
9.4	GENERAL REQUIREMENTS	8
9.4.1	Safety in Design	8
9.4.2	Plantroom Design	8
9.4.3	Service Ducts	9
9.4.1	Redundant Installation	9
9.4.2	Painting and Identification	9
9.4.3	Bearings and Drives	10
9.4.4	Gas Detection	11
9.4.5	Building Services Penetrations	11
9.5	MECHANICAL SYSTEMS	11
9.5.1	Air Conditioning Systems	11
9.5.2	Electric Motors	12
9.5.3	Chillers	12
9.5.4	Cooling Towers	12
9.5.5	Chilled Water Distribution	13
9.5.6	Packaged Air Conditioning Units	13
9.5.7	Heating Systems	14
9.5.8	Ventilation and Exhaust Systems	15
9.5.9	Pipework	18

9.5.10	Variable Speed Drives (VSD)	20
9.5.11	Fume Extract and Fume Cupboards	20
9.6	BUILDING AUTOMATION SYSTEM	21
9.6.1	General	21
9.6.2	Functional Control Description	21
9.7	MECHANICAL SERVICES – ELECTRICAL	22
9.7.1	Standards	22
9.7.2	Documentation	22
9.7.3	Location and Fixing of Cables	22
9.7.4	Balancing and Phase Rotation	22
9.7.5	Cable Selection	23
9.7.6	Busduct	23
9.7.7	Mechanical Services Switchboard (MSSB)	23
9.7.8	Isolation and Overload Protection	23
9.7.9	Controls and Indicators	24
9.8	TESTING, COMMISSIONING AND OPERATIONAL MAINTENANCE	24
9.8.1	General Requirements	24
9.8.2	Test Points for Measurements	25
9.8.3	Guarantee Tests of Major Items or Equipment	25
9.8.4	Testing and Commissioning	25
9.8.5	Operational Maintenance and As-built Information and Manuals	27

9.1 GENERAL

This section details the design principles and mandated minimum requirements to be addressed in the design and specification of mechanical services.

The designer is required to produce their own specification which incorporates the requirements set out in this and other sections of the University's Design Standards. The design documentation is not to reference this design standard.

This section of the Design Standards is to be read in conjunction with the other sections of the University's Design Standards, and in particular.

- Section 7 - Electrical Services.
- Section 10 – BAS & Controls.
- Section 16 - Laboratory Freezers and Refrigerators

In addition, the designer must comply with other design standard documents published on the Design Standards web page including:

- Computer Room Air Conditioning: The University of Melbourne Computer and Network Accommodation Strategy (CANAS) standard.

Should the designer identify any discrepancy between this section and other sections of the Design Standards or relevant statutory codes and standards, the more onerous requirement shall be adopted.

The design team is encouraged to innovate and may propose alternative design standards, however any departures from the Design Standards must be requested and approved via the Modification Request Form.

9.1.1 *Design Principles*

The mechanical services installation is required to optimise the total cost of ownership with respect to capital, energy, maintenance and renewal costs.

With a large property portfolio, the University also requires a consistent approach to system design, equipment types and sizing, particularly for maintainable assets or assets which have a user interface.

The mechanical systems are to be designed to ensure that they can be safely maintained and operated and ultimately renewed. The designer is required to include a plant access, maintenance and replacement strategy as part of the design development report.

The mechanical systems are to be designed to meet the approved project design criteria as set out in the project design brief. The design documentation shall ensure that the mechanical systems provide for easy future system modifications.

The mechanical systems for new buildings and large refurbishment projects are to be designed such that they are resilient to the impacts of a changing climate and natural disasters. A Climate Change Resilience Plan (refer to Section 3 - Sustainable Design) shall be provided with the system Pre-Design Report submitted to the University Project Manager for review.

For projects that include a Green Star Sustainability Rating outcome refer to Section 3: Sustainable Design of the Design Standards for details of the minimum requirements for Green Star points.

9.1.2 Heritage Requirements

Various buildings on the campuses are heritage protected. Mechanical services design and installation methods for these buildings require approval by the Heritage Consultant and the University's Project Manager.

The status of the building heritage is to be determined by the designer prior to commencing the design. A list of heritage listed buildings is available from the Heritage of Council Victoria and local Municipal Council's website.

The design for heritage protected buildings shall minimise interference with the original building fabric as far as practicable and is to specify the recording of original architectural details and locations in order to ensure accurate reinstatement.

All wiring and pipework shall be concealed within existing wall cavities. Where wall chases are unavoidable, approval by the Heritage Consultant must be obtained prior to works proceeding.

9.1.3 Standards and Regulatory Requirements

All work shall be designed to meet the requirements of national and local authorities and shall be in accordance with the following in so far as they apply to the work:

- National Construction Code (NCC) and Building Permit conditions
- Local Electricity, Water and Gas Authority requirements
- Australian Wiring Rules AS/NZS 3000
- Worksafe Victoria
- Occupational Health Safety & Welfare Act and Regulations
- Environment Protection Authority
- Australian Communications Authority (ACA)
- Gas Board Regulations
- Gas Installation Code
- Energy Safe Victoria Regulations and Legislation
- Disability Discrimination Act (DDA)
- All Health Authority Requirements
- Codes of Practice for the Control of Legionella
- Victorian Fire Brigade requirements
- All Local Council regulations
- State Government codes of practice for cooling towers

The works must also comply with all applicable Australian Standards. Note that the following list is not exhaustive, and the design team is required to inform themselves of all Standards which are relevant to the project.

Code	Description
AS/NZS 1132	Methods of tests for air filters for use in air conditioning and general ventilation
AS/NZS 1324.2	Air Filtration
AS/NZS 1345	Identification of the contents of piping, conduits and ducts
AS/NZS 1432	Copper tubes for plumbing, gas fitting and drainage applications
AS/NZS 1530	Methods of fire tests on building materials, components and structures

AS/NZS 1571	Copper seamless tubes for air conditioning and refrigeration
AS/NZS 1668	The Use of Ventilation and Air Conditioning in Buildings
AS/NZS 1677	Refrigeration systems
AS/NZS 1851	Maintenance of Fire Protection Equipment
AS/NZS 1894	The storage and handling of non-cryogenic and refrigerated liquids
AS/NZS 2243	Safety in Laboratories
AS/NZS 2625	Mechanical Vibration
AS/NZS 2670	Vibration
AS/NZS 2982	Laboratory design and construction
AS/NZS 3500	Plumbing and drainage
AS/NZS 3666	Air handling and water systems of buildings set
AS/NZS 3833	The storage and handling of mixed classes of good, in packages and intermediate bulk containers
AS/NZS 4254	Ductwork for air handling systems in buildings
AS/NZS 4289	Oxygen and acetylene gas reticulation systems
AS/NZS 4332	The storage and handling of gases in cylinders
AS/NZS 4603	Flashback arrestors – Safety devices for use with fuel gases and oxygen or compressed air
AS/NZS 5601	Gas Installations
AS/NZS 60079	Electrical Apparatus for Explosive Gas Atmospheres

9.1.4 **Design Change Authorization**

All requests for changes to the requirements of the Design Standards must be made on the Modifications Request Form.

No design work is to proceed on the basis of the proposed modification until the modification request has been approved in writing.

9.2 **DESIGN BRIEF**

If required to confirm the University of Melbourne requirements, the designer shall prepare a return Mechanical Services Design Brief that confirms the following key aspects of the proposed project:

- Scope of Works
- Works by Others and Associated Works
- Design Criteria
- System Description

9.3 GENERAL DESIGN CRITERIA

9.3.1 *Ambient Conditions*

The heating and cooling systems shall be designed to meet the University's internal design criteria, based on the ambient conditions specified in the "The Australian Institute of Refrigeration, Air-Conditioning and Heating (AIRAH) – Design Handbook" for location-based weather data for typical design summer and winter temperatures.

Plant & equipment providing comfort air conditioning shall be specified to continue to operate at an ambient air temperature of not less than 45°C. Note that for the Dookie campus this temperature limit shall be increased to 50°C.

The operating ambient temperature shall be increased to 50°C when the plant serves operationally critical areas such as computer rooms, server rooms etc.

9.3.2 *Internal Design Criteria*

Unless there are specific temperature and/or relative humidity requirements, comfort air conditioning shall be designed to maintain a temperature of between 20°C and 25°C.

In situations where there is potential to provide operational or sustainability benefits by modifying these design conditions, the designer shall consult with the Manager Engineering & Infrastructure. Approval to any proposed change to the design standards must be obtained via the Modification Request Form process.

9.3.3 *Occupancy*

Occupant numbers for any given zone are to be nominated by the architect in consultation with the University's Project Manager.

9.3.4 *Ventilation Rates*

Outside air ventilation rates to internal spaces shall achieve, as a minimum, the requirements defined in AS/NZS 1668.2.

Where Indoor Air Quality (IAQ) is a key consideration (i.e. meeting rooms, labs etc.), ventilation rates higher than the requirements set out in AS/NZS 1668.2 should be considered and balanced with energy related considerations.

Consideration shall be given to the use of CO₂ monitoring as a means of modulating ventilation rates to a given zone where occupancies vary significantly.

Naturally ventilated spaces intended for frequent occupation shall achieve at least the minimum ventilation rates as defined in AS/NZS 1668.4. This should be demonstrated by calculation at the design stage and, where required, verified with onsite measurement prior to practical completion.

9.3.5 *Filtration*

Filtration for comfort air conditioning systems shall be a minimum F6.

The air velocity of the filters shall not exceed 1.8m/s.

9.3.6 *Noise and Vibration*

Noise from mechanical services shall be free of tonal and spectral content, and not exceed the levels stated in the following table, when measured at a distance of 1.2m above floor level and 1.5m horizontally from any diffuser or plant enclosure (including services voids).

Space/Function	Noise Level (NR)
Lecture Theatres	30
Professional Suites, Associated Deans, Training, Conference and Seminar Rooms	38
Senior academic staff, academic offices, managerial offices, meeting rooms, syndicate and common rooms	38
Foyers, Corridors, Toilets and Store Rooms	45
Laboratories	40

Continuous noise level criteria are expressed in terms of Noise Rating (NR) Curves and measured in the octave bands 63Hz to 4kHz. Sound levels are measured in terms of Leq over a period of 60 seconds.

Refer to Design Standards Section 12: Acoustics, Vibration and EMI for more information.

The requirement for vibration isolation shall be assessed for all mechanical plant, equipment and distribution systems. Where required, anti-vibration mountings shall be provided.

The contractor is required to provide details of the location and type of anti-vibration protection to the University's Project Manager for approval prior to installation.

9.3.7 System Efficiencies

Plant shall be selected to achieve, as a minimum, the more stringent of NCC Part J requirements, relevant Australian MEPS and the criteria nominated below.

All plant selections shall be presented to the Manager Engineering and Infrastructure for approval prior to procurement. Where new technology offers potential for greater levels of efficiency these should be presented for consideration using the Modification Request Form. The additional efficiency benefits, including both initial and ongoing costs must be clearly presented.

Item	Efficiency
Pumps	>70%
Fans	>75%
Motors	Motors shall comply with the high efficiency requirements of AS1359.5:2000
Gas Fired Heaters	>82% Not more than 750kW >83% More than 750kW
Water Cooled Chiller	Minimum chiller IPLV/NPLV (measured to ARI550/590:1995) of: IPLV 5.5 — water-cooled chiller <500kW; IPLV 7 — water-cooled chiller >500kW; Note that part load and full load COPs are to be assessed to ensure ABGR requirements are achieved.
Air Cooled Chiller	IPLV 3.75 – Air Cooled Chillers
VRF/Split Systems	DX Air cooled packaged systems (including condenser): COP of 3.0. DX Water cooled package systems (excluding condenser): COP of 3.5

An Energy Impact Statement shall be completed for each new major University building project. This statement is intended to focus the attention of designers in all disciplines on solutions that ensure efficient energy use throughout the building's life. The statement shall be submitted to the Manager Engineering and Infrastructure at the design stage of the project.

9.3.8 Refrigerants

No equipment that requires the use of chlorofluorocarbon gases shall be specified.

The specification of all equipment utilising refrigerants shall be subject to the approval by the Manager Engineering & Infrastructure.

Offered refrigerants should have an Ozone Depletion potential of zero.

9.4 GENERAL REQUIREMENTS

9.4.1 Safety in Design

The Designer shall comply with the Occupational Health and Safety Regulations and assure that their design addresses the prevention of hazards or risks arising to health and safety out of the design through the construction and ongoing operation and maintenance of the mechanical services including their ultimate replacement.

Specific care shall be taken to ensure that the surrounding space and access routes are adequate for the safe maintenance and replacement of equipment.

The designer shall provide a documented Safety in Design report (refer to Section 2 – Health and Safety) that identifies risks and risk assessment methods used in the design process to eliminate or minimises the risks so far as reasonably practical related to the installation, operation and maintenance of the mechanical services.

9.4.2 Plantroom Design

Access

New plant rooms shall be provided with suitably sized access openings for removal and replacement of plant. Level access should be provided between plantroom and plant replacement route. Where level access cannot be achieved alternative measures such as access ramps and fixed lifting beams are to be provided to facilitate plant replacement.

The designer is required to include a plant access, maintenance and replacement strategy in the O&M manuals addressing each major plant item/system.

Plantrooms shall have restricted access by BiLock plantroom master key series only.

Structural Checks

Where new plant is to be installed in existing buildings, the designer/contractor shall obtain a Structural Engineers assessment of the resultant structural load against the buildings existing structural loading allowances.

The Consultant/Contractor is to ensure that there is adequate waterproofing applied to the plantroom floor.

Dust and Dirt Control

Plantrooms shall be provided with ventilation to maintain air quality and minimise the build-up of dust and other such small-scale dirt and debris.

During construction, modification and/or maintenance, all works in plant areas shall be carried out such that dirt and debris production is minimised. Following completion of

works, plantrooms shall be cleared of debris and receive a thorough clean. This shall be the responsibility of the Mechanical Contractor.

9.4.3 **Service Ducts**

Entrance doors to ducts shall be fitted with a night latch to suit a BiLock plantroom master key and shall be sufficiently sized to facilitate easy entry and have a 2-hour fire rating.

Large service ducts shall be fitted with sufficient lighting to facilitate inspection and repair work. Switches for these lights shall be located just inside duct entry doors.

Installation of grid flooring or vertical ladders in vertical ducts to facilitate inspection and repairs shall be provided.

240V power outlets shall be located close to duct entry doors so that they may be used for portable electric tools or inspection lamps in the duct etc.

One draw-wire shall be installed in small horizontal service ducts.

9.4.1 **Redundant Installation**

Any services installation made redundant by the works shall be disconnected and removed from the site.

9.4.2 **Painting and Identification**

Asset Identification

All plant and equipment shall be labelled and tagged in accordance with the University's Asset Services identification system as provided by the University Project Manager.

Painting and Colour Scheme

The painting of all plant and equipment which is not factory finished shall be carried out in accordance with the following standards:

- AS/NZS 2311 - The painting of buildings;
- AS/NZS 2312 - Guide to the protection of iron and steel against exterior atmospheric corrosion.

An appropriate painting system (including surface preparation, primers and finishes) for each application shall be nominated from a recognised referencing system such as GPC or APAS and submit to the University's Project Manager for approval.

The following paint colours shall be adopted for Mechanical Services:

Equipment	Paint Colour
Boilers	Oatmeal Y54
Pumps	Oatmeal Y54
Chillers	Oatmeal Y54
Heat Exchangers	Oatmeal Y54
Motors	Oatmeal Y54
Air Handling Units	White Y35
Fan Coil Units	White Y35
Ductwork (visible)	White Y35
Fans	White Y35

Packaged Air Conditioning Units	White Y35
Plenums, attenuators	White Y35
Flues and Exhausts	Aluminium

Services Distribution Labelling and Identification

Services distribution i.e. pipework and ductwork shall be identified in accordance with 'AS 1345 – Identification of the contents of pipes, conduits and ducts'.

Markings, labels and signs shall be located where they can be readily seen. This includes the use of self-adhesive markers indicating the service type and flow direction.

In general, label lettering should be a minimum of 30mm in height. Final lettering heights shall be suitable for the application given the local lighting conditions, the required viewing distance and status of the label or instruction.

Labels shall consist of two colour laminated plastic e.g. Traffolyte or similar approved system.

Warning and operational labels must be located to ensure visibility before any person is placed at risk. Labels should be applied to all internal MSSB equipment including filling the label compartments of all door mounted hardware.

Equipment Labelling

All items of equipment shall be suitably identified with Traffolyte labels, fixed with screws or pop rivets. Thermometers, pressure gauge tappings, remote sensing points and valves shall be similarly labelled to indicate their function.

A valve schedule shall be provided in the plant room indicating valve number and function.

Any hidden equipment shall be identified with a label placed on the ceiling or wall within 1 metre from the equipment. The label shall include identification of isolating valves, electrical circuit number, switchboard location, and the area (room number/s).

All plant shall be coded, compatible with the University's Asset Services identification system as provided by the University Project Manager.

9.4.3 Bearings and Drives

Lubrication of Ball and Roller Bearings

Where bearings require lubrication, they shall be fitted with grease nipples which are readily accessible. A lubrication schedule shall be included in the maintenance manual as per the manufacturer's recommendations.

Lubrication Points

Grease nipples shall not be painted but shall be fitted with removable yellow coloured caps with tethers attached to the equipment housing to prevent caps being lost during maintenance operations. Grease nipples, oil filling level and drain plugs shall be accessible on all items of equipment. Where access is difficult a central lubricating system shall be installed.

Machine Guards

Machine guards shall be applied to all rotating and oscillating equipment (e.g. pumps, fans, shafts, levers, arms, pushrods etc.).

All guards shall be of expanded metal, mesh or similar to enable easy inspection of the moving parts and belts. They shall be designed for ease of removal and re-attachment,

provided with sufficient space to allow for maximum belt stretch, and be strong enough to support the weight of a man.

Guards shall be designed to be lifted safely by one person by the incorporation of mechanical lifting devices or breaking the guards down into several lighter parts. All guards shall comply with current Australian Standards.

All belt drive equipment shall have a minimum of two vee belts. All equipment pulleys shall be equivalent to Taperlock cast iron pulleys. Aluminium pulleys shall not be used.

Motor mountings, slides or other equipment shall provide for simple and accurate belt tensioning and alignment and shall be rigid enough to resist flexing and vibration.

Maintenance manuals shall record belt and groove sizes.

Belt sizes and types shall be clearly indicated on machine housings to facilitate ease of maintenance by the use of permanently attached labels with engraved letters and numerals.

9.4.4 Gas Detection

All areas that house specialist gases are to be provided with depletion monitoring with alarm functionality and connection to the BAS.

9.4.5 Building Services Penetrations

All external services penetrations are to be sealed.

The design team shall clearly document all smoke and fire compartmentation on the services documentation. Where a penetration passes through a smoke or fire-resistant wall the penetration is to be provided with an approved barrier system.

Physical Containment laboratories shall have clearly documented containment and quarantine lines depending on the project.

Depending on the location of the penetration, thermal and/or acoustic barriers may also be required.

9.5 MECHANICAL SYSTEMS

9.5.1 Air Conditioning Systems

General Requirements

The University's Air Conditioning systems shall be designed to comply as a minimum with part J5 of the NCC.

Energy efficiency and acceptable comfort conditions shall be the prime consideration in the design of the air conditioning system.

Systems shall be effective in delivering the required conditions to each thermal zone and/or application. The designer shall assess the overall concept of system design based on all given standard and specific user information.

Systems shall be designed in accordance with Standard 55 of ASHRAE Thermal Environmental Conditions for Human Occupancy. For details refer to Section 3: Sustainable Design of the Design Standards.

There shall be inherent design features that permit ease of modification and flexibility to suit future room or partition layout changes.

Refrigeration plant type selection shall be based upon a life cycle analysis of the most effective and economic system available.

Closed cycle condensing systems such as evaporative condensers are preferred for heat rejection in lieu of open cooling tower systems.

Where appropriate, air cooled equipment shall be installed instead of cooling towers. In general, systems greater than 1,000 kW shall be water cooled chiller systems.

Consideration is to be given to utilising existing precinct/main plant infrastructure such as chilled water and heating water where practicable.

Externally mounted window air conditioning units are unacceptable and must not be used.

The design and location of equipment is subject to the approval from the Manager Engineering & Infrastructure.

Critical areas such as computer rooms, server rooms, etc. shall be provided with dedicated air conditioning systems and must not be part of the main building plant. Such systems shall also be connected to the BAS.

Application of Green Star credits

The Green Star credits referred to in this section apply, at a minimum, to new buildings and major building refurbishments.

9.5.2 *Electric Motors*

The University requires the use of 3-phase motors, complying with relevant international and Australian standards and MEPs High Efficiency Classifications.

The minimum IP rating for all motors shall be IP56.

9.5.3 *Chillers*

Air Cooled Chillers

Air-cooled chillers are to be sourced from manufacturers providing comprehensive performance data determined against a recognized performance standard i.e. ARI 550-590 and local maintenance support.

New air-cooled chillers shall achieve, as a minimum, the efficiencies detailed in Section 9.3.7.

Water Cooled Chillers

Water-cooled chillers are to be sourced from manufacturers providing comprehensive performance data determined against a recognized performance standard i.e. 'ARI 550-590 and local maintenance support.

New water-cooled chillers shall achieve, as a minimum, the efficiencies detailed in Section 9.3.7.

A refrigerant gas leak detection alarm is to be interlocked with the operation of the Chiller. An alarm notification shall also be sent to the Building Automation System (BAS).

9.5.4 *Cooling Towers*

The designer shall be thoroughly familiar with the Victorian Government's 'Guidelines for the Control of Legionnaires Disease' and adhere strictly to those guidelines in their design.

Cooling tower discharge shall be separated by adequate distance from any fresh air intake to prevent entrainment of cooling tower flume

Cooling tower intakes shall be separated by adequate distance from all exhaust systems that could contaminate the condenser water system.

The University will only consider towers that comply with AS/NZS 3666. Cooling towers shall have drift eliminators installed to prevent water loss as per the applicable Victorian Government regulations.

Tower fans are to be controlled through a Variable Speed Drive (VSD).

Stainless steel basins and components shall be used where exposed to moisture.

Adequate space shall be allocated for effective and unhindered maintenance.

Cooling towers shall be set out in accordance with the manufacturer's recommendations to ensure maintainability and adequate air flow through the tower and separation between air inlets.

Acoustic performance requirements are required to be considered in the selection, location and acoustic treatment of cooling tower installations.

Cooling tower make up water supply lines are to be fitted with water meters with connection to the BAS.

All cooling tower sizing exercises shall include a water quality assessment such that bleed rate and blow down requirements can be accurately determined.

Attention is drawn to the appropriate regulations for the disposal of tower waste water. The designer to incorporate the capture, treatment and potential reuse of bleed and blow down water as a means of reducing overall water consumption.

In accordance with Green Star Credit 18A.1, the Potable Water may be used where appropriate to reduce the buildings predicted water usage. Correct filtration methods shall be used in line with the manufacturers recommendation where potable water is used.

9.5.5 Chilled Water Distribution

The chilled water system shall be designed to provide energy efficient chilled water distribution and high levels of flow control.

Individual high spots in a system shall be minimised.

Air and dirt separators are to be installed when upgrading CHW central plant or when a new central system is installed.

To provide for system maintenance, isolating valves shall be installed to each circuit in accessible locations and clearly shown on the schematic design.

Temperature and pressure gauges capable of connection to the BAS for remote monitoring shall be installed on both the supply and return lines of all systems. Temperatures gauges to be installed in plantroom areas.

9.5.6 Packaged Air Conditioning Units

The use of package air conditioning systems is only acceptable where no centrally distributed water services are available, i.e. chilled water for cooling and/or hot water for space heating.

Packaged air conditioning units refers to the following equipment types:

- Rooftop packaged units;
- Single split DX units;
- Multiple indoor unit Variable Refrigerant Flow (VRF) systems;
- DX/VRF Systems with air cooled condensers;
- DX/VRF Systems with water cooled condensers.

For all proposed works involving packaged air conditioning units the designer/contractor is required to provide documentary evidence to the Manager Engineering and Infrastructure that the availability of centrally distributed services has been investigated.

New packaged systems should achieve, as a minimum, the efficiencies detailed in Section 9.3.7.

9.5.7 Heating Systems

General Requirements

Heating systems shall be provided to all occupied areas and to specific applications (e.g. constant temperature rooms, animal houses etc.) as nominated by the University.

Energy efficiency is of prime consideration. Systems shall be effective in delivering the required conditions to each thermal zone and/or application.

The University's heating systems are to be designed to comply with part J5 of the NCC.

Boilers/Water Heaters

The University requires boilers to be fired with gas and be fully automatic. All boiler rooms shall be supplied with audible gas monitors/alarms with a link to the Building Automation System (BAS). A Gas Leak alarm isolation button is to be located outside the plantroom. Boiler/water heater installations should conform to the following standards:

- AS/NZS 1375 - SAA industrial fuel appliances code;
- AS/NZS 3100 - General requirements for electrical equipment;
- AS/NZS 3892 - Pressure equipment – installation;
- AS 3920:1 - Assurance of product quality - Part 1: pressure equipment manufacture;
- AS/NZS 5601 - Gas installations;
- BS 7190 - Method for assessing thermal performance of low temperature hot water boilers using a test rig.

Fully modulating burners compliant with the current regulations complete with an approved firing programmer are to be provided and able to be locked onto low fire.

All boilers shall have an interlock with the boiler pump and a supply air fan. Gas leak detection alarm is to be interlocked with the operation of the boiler.

All gas lines to boilers shall be fitted with usage meters capable of connection to the University's BAS System.

Multi-boiler systems are preferred in lieu of a single boiler for standby capacity.

New Boilers/Water Heaters should achieve, as a minimum, the efficiencies detailed in Section 9.3.7.

Low Temperature Heating Water Distribution

The number of individual high spots in a system shall be minimised.

Air and dirt separators shall be installed when upgrading HHW central plant or when a new central system is installed.

To provide for system maintenance, isolating valves shall be installed in each circuit in accessible locations and clearly shown on the schematic design.

Temperature and pressure gauges connected to the BAS are to be installed on both the supply and return lines of all systems.

Space Heating Equipment

Where dedicated space heating is provided such as radiators, trench heaters and convectors they should conform to the following standards:

- AS 1571 – Copper-seamless tubes;
- BS EN 442-1, -2 and -3: Specification for radiators and convectors.

Such systems are to be installed to the manufacturer's specification by a suitably qualified installer and subsequently pressure tested.

Panel radiators/connectors shall be equipped with automatic temperature control valve and balancing valve. Valves to be provided with isolation capability.

Direct electric heating devices including radiant panel heaters are not to be used.

9.5.8 Ventilation and Exhaust Systems

General Requirements

Fresh air shall be supplied to the building in accordance with AS/NZS 1668.2, refer also to Section 9.2.4.

Internal exhaust ducts shall be connected to the fan suction side of the system. Exhaust outlets shall be arranged to avoid contamination of air intakes, opening windows, doors, wall vents or other building openings. Exhausts shall be positioned above roof level and comply with the relevant Regulations and Australian Standards. Notwithstanding such Regulations, the positioning shall be such as to ensure safe operation. Inlet louvres shall be located away from any possible sources of contamination. Inlets shall be located at least 6 meters away from exhaust locations.

Outside air shall not be drawn through plant rooms to inlet plenums. If necessary, outside air may be ducted to inlet plenums direct from outside, providing the ducting does not affect plant room use.

Fire and smoke damper locations shall be identified with a permanently attached engraved label placed where it is easily visible from within the occupied area of the room. New fire dampers shall be either fully actuated or of the fusible link type. For the latter, dampers should be provided with a contactor such that the BAS shall monitor damper position. Access panels shall be provided either side of smoke and fire dampers to facilitate periodic inspection, cleaning and maintenance.

All building areas served by an extract ventilation system shall be maintained at negative pressure. Similarly, all building areas served by supply ventilation system shall be maintained at positive pressure.

Thermostat controlled exhaust systems shall be provided to all new main switchrooms.

Air Handling Units

Air handling units should be capable of delivering air at the design supply temperatures throughout the year with fan motor input powers compliant with Section J5 of the NCC.

Air conditioning systems should be provided with an economy cycle feature as a means of reducing energy consumption.

All air conditioning systems over 35kW_r shall be provided with economy cycle operation in compliance with Section J5.2 of the NCC.

Where enthalpy control is provided there shall also be a mechanism that locks out and protects the system from inappropriate economy cycle operation upon failure of a humidity sensor.

Air handling unit installations should comply with all relevant standards including the following:

- AS/NZS 1668:1 - Fire and smoke control in multi-compartment buildings.
- AS4254 - Ductwork for air handling systems in buildings.
- ANSI/ARI 430 - Central station air handling units.

Air handling units should achieve, as a minimum, the efficiencies detailed in Section 9.3.7.

Air handling units shall be located and arranged relative to other services such that all components are readily accessible for maintenance. The design shall provide adequate space to allow the largest components to be removed unimpeded.

Unit selections shall incorporate internal lights where they are accessible.

Installations to be coordinated with all other services and building structure.

Fan Coil Units

New fan coil unit installations shall, as a minimum, achieve motor input powers compliant with Section J of the NCC.

Fan coil unit installations should comply with all relevant standards including the following:

- AS/NZS 1668:1 - Fire and smoke control in multi-compartment buildings;
- AS4254 - Ductwork for air handling systems in buildings;
- ANSI/ASHRAE 79 - Methods of testing for rating room fan-coil air conditioners;
- ARI 440 - Room fan-coil and unit ventilators.

Fan coil unit installations must be fully accessible in all ceiling types. Allow to provide ceiling access panels in suitable locations such that all control panel, isolators and filters are accessible.

Installations to be coordinated with all other Services and building structure.

Air Filters

Where new air handling systems are provided filters are to be provided in accordance with the following standards:

- AS 1324.1 - Air filters for use in general ventilation and air conditioning - application, performance and construction
- AS 1324.2 - Air filters for use in general ventilation and air conditioning - methods of test
- AS/NZS 1530.3 - Simultaneous determination of ignitability, flame propagation, heat release and smoke release
- AS/NZS 1668.1 - Fire and smoke control in multi-compartment buildings
- AS 1668.2 - Mechanical ventilation for acceptable indoor air quality
- AS 1807.9 - Particle counting in clean rooms by microscopic sizing and counting
- AS 1807.7 - Determination of integrity of HEPA filter installations not terminally mounted
- AS 3666 - Air handling and water systems for buildings - microbial control
- AS 4260 - High efficiency particulate air (HEPA) filters - classification, construction and performance.

All new air filters must be serviced periodically during the defects liability period by the installing contractor.

Diffusers

Diffusers shall be selected to provide adequate air distribution and occupant comfort conditions for all supply conditions throughout the year.

For air conditioning applications selected terminal devices shall achieve an Air Diffusion Performance Index (ADPI) of 80 or better when tested against 'ANSI/ASHRAE 113: Method of testing for room air diffusion'.

Ductwork

Ductwork shall comply with all relevant standards, including but not limited to, with the following:

- AS 4254.1 & 2 - Ductwork for air-handling systems in buildings
- AS 1668.1 - Fire and smoke control in multi-compartment buildings;
- AS 1668.2 - Mechanical ventilation for acceptable indoor air quality
- AS 1682.1 - Fire dampers, specification
- AS 1682.2 - Fire dampers, installation
- AS 3666 - Air-handling and water systems of buildings - microbial control

Flexible duct shall be non-perforated type and shall comply with AS 4254.2 and the NCC. Flexible duct shall only be used on the final connection from the rigid duct to air terminal device.

Flexible ductwork is not permitted on hazardous exhaust systems or clean room systems.

All ductwork is to be insulated in accordance with part J5 of the NCC.

A sufficient number of bends and internal insulation is to be provided on ductwork passing over/through sound attenuated walls and through baffles.

Fans

Fans shall achieve, as a minimum, the efficiencies detailed in Section 9.3.7. Fan motor input powers shall be compliant with Section J5 of the NCC.

Fan installations shall comply with all relevant standards including the following:

- AS 1668.1 Fire & Smoke Control.
- AS 4429 Smoke Spill Tests.
- BS848 Part 1 Air Flow Tests.
- BS848 Part 2 Noise Tests.

Pumps

Pump selections shall be based on calculated system duty points, calculations shall be carried out based on ARIAH Design Guides and installation drawings and selected equipment to determine the respective system pressure losses and final pump selection.

Design head not to exceed 90% of the pump capacity.

Pumps shall comply with [ISO or DIN standards.

Pumps 5.5kW and over shall be long coupled end suction type. Pumps below 5.5kW may be inline or short coupled.

Pumps are to be provided with the following features:

- Balanced/unbalanced mechanical seals suitable for the system operating pressures and temperature.
- Guarding of moving parts as per the relevant Australian Standards.
- Flexible couplings, supply and discharge on the horizontal legs.
- Drained drip trays.
- Gauges (suction/discharge)

Pump installations shall include:

- Isolation valves.
- Suction strainers.
- Check valves.
- Variable speed devices.

Domestic hot water circulating pumps shall be made of bronze or stainless steel (Grundfos or approved equivalent).

9.5.9 Pipework

Pipework design, installation and testing shall comply with all applicable Australian Standards including the following:

- AS 4041 - Pressure piping to statutory requirements;
- AS 2129 - Flanges for pipes, valves and fittings;
- AS 2528 - Bolts, stud-bolts and nuts for flanges and other high and low temperature applications;
- AS5601 - Gas installations;
- AS/NZS 3500.1.1 - Performance requirements;
- AS/NZS 3500.1.2 - Acceptable solutions;
- AS 3500.4.1 - Hot water supply systems;
- AS/NZS 3500.4.2 - Hot water systems;
- AS 1722.1 - Pipe threads of Whitworth form - sealing pipe threads.

Piping systems should be provided in accordance with the following table.

System	Type	Material
Cold Water	Open	Copper
Condenser Water	Open	Copper, Stainless Steel 316L
Compressed Air	Open	Less than 20 mm dia - Copper, Other - Galvanised Steel or polyethylene
Chilled Water	Closed	Less than 100 mm dia - Copper, Other – Copper or carbon steel
Drains	Open	Copper or UPVC
Floor Heating	Closed	Polyethylene
Heating Hot Water	Closed	Less than 100 mm dia – Copper Other - Copper or carbon steel
Natural Gas	N/A	Copper or steel to AS 5601
Vents	Open	Copper

All external pipe work i.e. exposed to weather, etc. (including refrigerant lines) shall be insulated and encased in galvanised metal cladding or an equal or approved alternative.

All pipe work shall be identified in accordance with Section 9.4.2. Flow direction arrows shall be provided to all pipe work in accordance with the above section.

All exposed pipe work in plant rooms and risers shall be clearly labelled to indicate the purpose of the pipework service, direction of flow and, if relevant, hazards.

All pipe work shall have test points, air bleeds and drains to ensure reliable operation and ease of maintenance.

Strainers shall be installed on the supply side of pumps.

Provide temperature and pressure gauges with a link to the BAS for remote monitoring on the flow and return lines.

Air bleeds and air / dirt separators are to be fitted to all heating and chilled water systems.

Electrolysis protection for inground services shall be provided.

Refrigeration pipework

Refrigeration pipe work exceeding 10 metres in length and on branch tee's shall have service isolation valves provided in the suction and discharge lines.

Long refrigerated pipe runs shall be in accordance with manufacturer's recommendations.

Pipework supports, anchors and movement joints

Pipework support to be provided in accordance with the following standards:

- AS 4100 – Steel structures;
- AS 4041 – Pressure Piping;
- AS/NZS 3500.1 – National Plumbing and Drainage Code.

Movement, vibration and thrusts are to be calculated and appropriate fittings provided to counteract such effects.

Valves

The University requires isolating & balancing valves in heating and cooling water pipelines.

All similar valves shall be of one manufacture. Valves shall be approved by the Manager Engineering and Infrastructure.

Globe valves shall be used for the control of steam.

The University requires the use of STA-T Balancing Valves, where applicable, in water circuit: with isolating valves up-stream of STA-T valves.

Isolating valves must be installed at each floor to allow isolation of systems without the need for draining the whole circuit.

In general valves shall be as follows;

- Ball valves to be used up to 50mm
- Victaulic manufacture butterfly valves to be used for valves 65mm and above.

HHW and CHW headers shall be provided with STA-T valves on the return side, with ball valves and Victaulic manufacture valves on the supply side.

Insulation

Insulation provided shall be compliant with Section J: Energy Efficiency of the National Construction Code (NCC) and should have zero Ozone Depletion Potential (ODP).

Insulation shall comply with all relevant standards including the following:

- AS 1530.3 - For all internal and external surfaces of ductwork;
- AS 1668:1 – Fire and smoke control in multi-compartment buildings;

- AS 2352 - Glossary of terms for thermal insulation of buildings;
- AS 4254 – Ductwork for air-handling systems in buildings;
- AS 4508 - Thermal resistance of insulation for ductwork used in building air conditioning.

Insulation shall be provided to mechanical services to limit heat loss or heat gains, prevent condensation and ensure fluids are delivered at required conditions at point of use. Applications included but are not limited to the following:

- Supply air systems ductwork;
- Return air systems ductwork;
- Spill air system prior to heat exchanger;
- Re-circulation ductwork;
- Air handling plants;
- Heat exchangers;
- Water heaters and flue systems;
- Storage tanks;
- Heating fluid headers, pipelines, valves, strainers and other fittings;
- Hot water supply headers, pipework, valves, strainers and other fittings.

9.5.10 Variable Speed Drives (VSD)

Variable Speed Drives shall be of Danfoss or ABB manufacture.

VSD's shall be installed no further than 1500mm from the equipment served.

Drives must not be installed at high level and shall be operable from floor level.

All VSDs shall be provided with isolators immediately upstream of the drive.

Labelling shall be provided on the VSD indicating the equipment it is serving and the switchboard that is supplying it.

In addition, the labelling shall include the relevant safety and fire mode labelling in accordance with Australian Standards on the front of the drive.

Labelling shall be Traffolyte. Dymo/Brother type labelling shall not be used.

9.5.11 Fume Extract and Fume Cupboards

Fume cupboard installations

Fume cupboard installation shall comply AS/NZS 2982 Laboratory Design and Construction standard and be appropriate for the use specified in the client brief.

Fumehoods are to be fitted with an appropriate mesh at the discharge outlet.

Fumehoods duct fire protection method will be either fire collars or fire dampers. The preferred design will require evaluation by the Fire Services Engineer and Building Surveyor.

Installation guidelines for fume cupboards include, but not limited to, AS2243 part 8.

Due to the close proximity of buildings on the University's main campus at Parkville, plume studies may be required for any fume cupboard installation.

Fume cupboards must be provided with LED lighting and automatic lowering sashes for energy efficiency.

Testing

All tests shall include face velocity, smoke, operation of controls and emergency button, condition of fans, belts, and bearings.

All tests shall be carried out by an independent NATA (National Association Testing Authority) accredited organisation approved by the University's Project Manager, and tested to AS2243.9. A copy of the calibration certificate for the instrument is to be included in the report.

Fan specifications are to be included in the test report giving details of fan, motor, total fan static pressure, total fan duty (l/s) measured in exhaust duct, make model and type of fan and operation details. The fan can be a belt driven or direct drive centrifugal fan and shall be capable of a 20% increase over the air quantity specified.

Extraction outlets shall maintain a safe distance from any operable intake in accordance with AS/NZS 1668.2.

Belt driven fans are to have a minimum of two belts on the drive train.

Instruments used for testing

The instrument to be used for testing fume cupboards shall be of the hot wire type. At the time of use, the instrument shall have a current NATA-issued certificate.

Hot wire anemometer readings shall be corrected against the calibration certificate.

Commissioning

All commissioning results shall be submitted in written format as agreed with the Manager Engineering and Infrastructure.

9.6 BUILDING AUTOMATION SYSTEM**9.6.1 General**

The Building Automation System shall comply with the requirements set out in

- Building Automation Systems (BAS): Section 10 – BAS & Controls.

9.6.2 Functional Control Description

The designer shall prepare a functional monitoring and control description that includes details of the global control functions provided including operational priorities, including the following as applicable:

- Fire mode
- Power failure and power fail restart
- Optimal start / stop
- Night purge
- Normal occupancy hours
- After hours operation

Details of the individual equipment control strategies and sequences complete with the following details:

- Plain English overview of the control strategy or sequence
- Sequence of automatic operation for all operating modes such normal, after hours, fire mode, etc.
- Sequence charts where applicable
- Details of all other interdependent control strategies, both parent and child

- Fault sequences including return to normal operation
- Duty or sequence roll over where applicable
- All associated physical and virtual BMCS points
- All operating setpoints and control parameter values
- All trend point logging and defined intervals
- All point alarming including alarm designation, actions and priorities

9.7 MECHANICAL SERVICES – ELECTRICAL

9.7.1 *Standards*

The installation shall comply with requirements of the Local Supply Authority Services Rules and all applicable regulations and Statutory Authority requirements.

Work not covered by the requirements of Statutory Authorities shall comply with the latest edition of the appropriate publication from the Standards Association of Australia and in particular the following standards;

- AS/NZS 3000 – Wiring Rules
- AS/NZS 3008 - Electrical installations – selection of cables – Cables for alternating voltages up to and including 0.6/1 kV
- AS/NZS 3111 - Approval and test specification- Miniature overcurrent circuit-breakers
- AS/NZS 3947.3 - Low voltage switchgear and control gear - Switches, disconnectors, switch-disconnectors and fuse-combination units

Refer to Section 7: Electrical Services for cable selection and installation requirements.

9.7.2 *Documentation*

Fully detailed drawings and schematics showing the proposed electrical installation shall be provided for review of the Manager Engineering and Infrastructure.

Functional schematic diagrams shall be prepared in a form which illustrate the electrical relationship between items of equipment, the sequence of operation and the control and protective functions.

9.7.3 *Location and Fixing of Cables*

Wiring within the ceiling space shall be run in an orderly manner parallel to the structure and on either cable trays, catenary wires or other method approved by the University's Project Manager.

Wiring within plant room areas shall be surface mounted on cable tray or in conduit and concealed within the building fabric in areas external to the plant room. Surface mounted conduit on building facades shall be avoided.

Except at tunnel-type terminals, all conductors shall be terminated with an industry standard clamp or crimp-type cable lug.

9.7.4 *Balancing and Phase Rotation*

Balancing and phase rotation shall be in accordance with AS/NZS 3000. The contractor must balance each section of the installation evenly over all phases and ensure that phase rotation is correct throughout.

9.7.5 **Cable Selection**

The minimum size of conductors shall be 2.5mm² for power on a 16 Amps circuit, 4mm² for power circuits on a 20 Amp circuit and 1.5mm² for control wiring using multi-strand copper conductors. See Design Standards Section 10: BAS and Controls for further specification of controls wiring.

Copper conductor fire rated cabling shall be used to supply all Life Safety Services equipment and control services. Aluminium cables shall not be used.

The project Consultant shall undertake all calculations necessary to ensure cables are installed in accordance with regulatory standards and requirements, based on final equipment selections, loads and length of cabling.

Equipment deemed as Life Safety Services equipment to run under fire conditions shall be wired with fire-rated cable and equipment as per AS/NZS 3000, AS/NZS 3013, AS/NZS 3008, AS/NZS 1668 etc.

Isolators used for Life Safety Services equipment e.g. smoke exhaust fans shall be locked in the ON position and be labelled

“WARNING: THIS ISOLATING SWITCH MUST BE LOCKED IN THE ‘ON’
POSITION AS THE FAN IS REQUIRED TO OPERATE DURING A FIRE.”

9.7.6 **Busduct**

Copper conductor busduct systems may be used in certain installations where appropriate. In general, busduct may be used to supply high current, non-fire rated loads. Early approval of the use of busduct is to be obtained from the Manager Engineering and Infrastructure.

9.7.7 **Mechanical Services Switchboard (MSSB)**

Refer to Section 7: Electrical Services for details of MSSB and switch gear design and selection requirements.

During construction, on-site drilling or cutting may be required within the MSSB and/or controls cabinet. Where this occurs, filings, swarf, etc. shall not be allowed to lodge in electrical components. Cabinets shall be well cleaned out using vacuum cleaners, etc. at the completion of work.

9.7.8 **Isolation and Overload Protection**

Contactors and thermal overloads shall be as manufactured by Sprecher and Schuh, Telemecanique, or Moeller.

Isolating switches shall be provided adjacent to all items of equipment.

Isolator shall be rated at:

- AC-21 for normal switching duty.
- AC-23 for motor starter duty.

Short circuit protection may be provided by circuit breaker protection device.

Circuit breakers shall be Terasaki, Merlin Gerin or Moeller.

The capacities and types shall be chosen according to the manufacturers' recommendations, with due regard for the temperature of their location, frequency of operation, etc.

9.7.9 Controls and Indicators

Where extra low voltage controls are employed the preferred voltage is 24V.

Where appropriate, each control circuit shall be provided with a labelled selector switch offering the choice of AUTO-OFF MAN, AUTO-MAN or selector switch as required. See Section 7: Electrical Services for the labelling of switches for remote control wiring. Where appropriate, equipment controlled by the MSSB shall include indicating lamps. Lamps shall be LED type and be of 22mm diameter.

Colours:

- GREEN indicates 'ON';
- RED indicates 'FAULT';
- RED indicates 'FIRE alarm'.

The panel design shall provide a test push button to check that all lights operate. The incoming electrical supply to the MSSB shall be fitted with current transformers and a Multi-function Energy Meter (MFM) shall be provided.

As a minimum the MFM shall have a LED or LCD display and provide the following functions:

- Current in all three phases (Amps);
- voltage each phase to neutral (volts);
- voltage between phases (volts);
- total load (kW).

The MFM shall be provided with a high level interface to the University BAS.

9.8 TESTING AND COMMISSIONING

9.8.1 General Requirements

A list of all systems proposed to be tested and commissioned shall be provided to the Manager Engineering and Infrastructure for review and approval a minimum of 2 weeks prior to the testing and commissioning date.

On completion of the project works, the installation is to be commissioned in all modes of operation including fire mode testing.

The Contractor is to carry out comprehensive pre-commissioning, commissioning and quality monitoring in strict accordance with CIBSE Commissioning Codes or the HVAC&R Technical Requirements for the Commissioning Process published by ASHRAE (2007) to satisfy the relevant Green Star Commissioning Credit 2.2. Refer to Section 3: Sustainable Design for details of the minimum requirements for Green Star points.

Qualified technicians shall undertake testing and commissioning with appropriately calibrated equipment to carry out such tests as may be necessary to satisfy the Independent Commissioning Agent (ICA) that the installation meets the requirements of this Design Standard. All test instruments/equipment are to be calibrated at an approved N.A.T.A. certified laboratory prior to carrying out the tests. ICA's will be appointed by the University for all new build projects, this is also in line with Green Star Credit 2.4. Refer to Section 3: Sustainable Design for details of the minimum requirements for Green Star points.

All pre-commissioning information, commissioning data, test records etc. shall be provided to the Manager Engineering and Infrastructure in a report format prior to practical completion.

In accordance with Green Star Credit 2.1, a services and maintainability review shall be undertaken during the design phase of the project. The review shall include input from the University and shall address the following;

- Commissionability
- Controllability
- Maintainability
- Operability, including fitness for purpose
- Safety

Refer to Section 3: Sustainable Design for details of the minimum requirements for Green Star points

Application of Green Star credits

The Green Star credits referred to in this section apply, at a minimum, to new buildings and major building refurbishments.

9.8.2 Test Points for Measurements

The project specification shall require the provision of properly designed test points for the measurement of all pressures, flows, temperature, etc. necessary for commissioning and performance testing. Such test points shall become part of the final installation so that they are available to the University for performance checks and fault finding during the operating life of the equipment.

9.8.3 Guarantee Tests of Major Items or Equipment

The performance of the boilers, chillers, cooling towers and other major plant items shall be demonstrated to operate at both peak and part loads and where required tested offsite prior to delivery. Testing procedures including methodology, testing standards, test rig details and testing outcomes shall be provided to the Manager Engineering and Infrastructure in for approval. Documentation is to include the following:

- Description of tests undertaken;
- Locations of test runs (i.e. on site, at manufacturer's premises or other location);
- Details of test rigs including method for simulating load;
- Where equipment fails to achieve specified design loads, remedial action and successful re-testing is to be undertaken prior to practical completion.

The Consultant's specification for the project shall clearly state what testing information is required for each item of equipment undergoing performance testing.

The designer/contractor shall be fully responsible for costs and programme implications of underperforming equipment.

9.8.4 Testing and Commissioning

The design consultant shall develop testing instructions and performance data sheets. The level of detail required, along with sample sets of such test and data sheets shall be reviewed by the Manager Engineering and Infrastructure. The design consultant shall draw up testing instruction and data sheets appropriate to the particular job and include them as part of the Mechanical Services specification.

The specification must require the contractor to prepare the equipment in all respects for the tests and advise the consultant of the date and time for their performance. Engineering and Infrastructure Services shall also be advised so that a suitably qualified University officer can be present to witness the tests.

All equipment shall be commissioned and fully operational prior to practical completion. All commissioning shall be undertaken by NEBB qualified personnel and in accordance with NEBB procedures.

Copies of the completed performance test sheets shall be included in the Operating and Maintenance manuals (O&M).

All systems are to be tested to the satisfaction of the design consultant and the University and in strict accordance with the CIBSE Commissioning Codes or ASHRAE Commissioning Guideline 1-1996 to satisfy the relevant Green Star Commissioning Credits. Refer to Section 3: Sustainable Design for details of the minimum requirements for Green Star points.

In addition to the design consultant's requirements for systems testing and commissioning, the following systems shall also be tested and commissioned;

- Plant and equipment
- Controls
- Air Systems
- Variable Air Volume (VAV) systems
- Water systems
- Water treatment systems
- Condensate systems
- Refrigeration systems
- Natural gas systems
- Compressed air systems
- Mechanical electrical systems

All adjustments necessary for the safe, reliable and satisfactory operation of the plant prior to the practical completion. The Certificate of Practical Completion is not to be issued until after the plant has been inspected and approved and the requirements of this section of the specification are fulfilled.

Building system tuning

In accordance with Green Star Credit 2.3, tuning and adjustments of all building systems is to be provided on a quarterly basis for a period of 12 months from date of Practical Completion.

The objectives of the building tuning process are as follows:

- Verify that systems are performing to their design potential during all full and part load conditions;
- Reviews of environmental performance against the environment targets;
- Collection of user feedback to match the system performance with the occupant's needs;
- Adjustment of all the systems to account for all deficiencies discovered;

A building tuning report shall be provided to Engineering and Infrastructure Services which reports the outcomes of the quarterly tuning process.

Refer to Section 3: Sustainable Design for details of the minimum requirements for Green Star points.

9.8.5 Operational Maintenance and As-built Information and Manuals

The design consultant must ensure that the project documentation includes a requirement that all installations are provided with a 12-month maintenance period from the date of Practical Completion. Routine and regulatory maintenance shall be scheduled per the manufacturers and regulatory requirements. Monthly maintenance reports shall be provided to Engineering and Infrastructure Services for the University's records and information.

Refer to the University's CAD Standards for details of the formatting and submission requirements for as-built drawings, manuals and warranties. The CAD Standards can be found in the Associated Documents Section of the Design Standards web page.

O&M manuals are to comprise, but not limited to, the following;

- Maintenance manuals and instructions
- Maintenance reports
- General description of plant and systems
- As-installed/built drawings
- Plant operating instructions
- Schedule of technical data
- List of equipment suppliers
- Equipment literature
- Routine and preventative maintenance instructions
- Copy of the completed training records
- Product warranty certificates
- Copies of all test and approval certificates
- Detailed operating methodology for equipment and systems such that the reader can clearly understand the scope and performance of facilities provided;
- Consultants design specification relevant to the works;
- Function, normal operating characteristics and limiting conditions of equipment;
- HVAC equipment lists and manufacturers information
- Systems commissioning data, test sheets and instrument calibration certificates.
- Contact details for Consultant, Contractor, Sub Contractors, Commissioning Agents and other responsible parties.
- Details of consumables and spares (filters, fan belts etc).
- Plant access, maintenance and replacement strategy.
- Local Authorities certificates.
- Registrations (as applicable) in the name of the University of Melbourne.

Draft manuals, inclusive of all the above noted items are to be provided four weeks prior to practical completion. Final manuals are required a maximum of four weeks after practical completion.

Systems Specialists Visits

Prior to practical completion, the Manager Engineering and Infrastructure shall be provided with details of any ongoing servicing requirements requiring the attendance of a manufacturer trained specialist. eg. proprietary systems.

Breakdown Emergencies

There are a number of occasions when malfunctioning of service equipment causes inconvenience to users or damage to new buildings during the Defects Liability Period (DLP). University service departments employ suitable tradespersons, who are often able to take remedial action much quicker than the Contractor or the Contractor's Sub-contractor, thereby minimising damage and inconvenience. In addition, the University operates a roster system to deal with out-of-hours emergencies. In many breakdown emergencies, use of University staff would be mutually advantageous to the Contractor and the University.

The contract documentation is to state that occasionally the University, without obligation and without prejudice, may make service staff available for emergency work under the following rules:

- The Contractor or Sub-contractor shall be notified that an emergency fault exists and agreement as to who will handle the job shall be reached.;
- If the Contractor or Sub-contractor cannot be contacted, the University may, at its discretion take remedial action;
- If more than two hours work is involved, the University may claim reimbursement at normal overtime rates. For work of a lesser magnitude no charge will be made for the service;
- University staff shall exercise care in the performance of these jobs but shall not guarantee success or assume responsibility for subsequent faults or consequential damage resulting from failure.
- The Contractor's responsibilities under the contract will not be diminished by any breakdown emergency action undertaken by the University or its agents.

SECTION 10: BAS & CONTROLS CONTENTS

10.1	INTRODUCTION	3
10.2	GENERAL SYSTEMS AND STRATEGY	3
10.2.1	Future Direction: The BAS Strategy	3
10.2.2	BAS Migration Plans	4
10.3	AUSTRALIAN STANDARDS AND CODES	5
10.4	GENERAL REQUIREMENTS	5
10.4.1	Point Schedules	5
10.4.2	BAS Ethernet Networks	6
10.4.3	LON & BACnet Open Communication Protocols	6
10.4.4	DDC Network Controllers	6
10.4.5	DDC Field Controllers	7
10.4.6	High Level Interfaces (HLI's)	8
10.4.7	BAS Spare Capacity	8
10.4.8	BAS Product Support	8
10.4.9	Criteria for Connection to BAS	9
10.4.10	Safety	9
10.4.11	Energy & Water Conservation	9
10.4.12	Motion Detector Equipment	10
10.4.13	Temperature Monitoring	10
10.4.14	Status Monitoring	10
10.4.15	Set Point Adjustments	10
10.4.16	Liaison	11
10.4.17	Labelling	11
10.4.18	Commissioning	11
10.4.19	Training, As-Built Drawings, Operating & Maintenance Manuals	12
10.5	HARDWARE REQUIREMENTS	12
10.5.1	Input / Output	12
10.5.2	Direct Digital Control (DDC) Controller	13
10.5.3	Temperature Sensors	13
10.5.4	Pressure Switches	13
10.5.5	Pressure Sensors	13
10.5.6	Damper Actuators	14
10.5.7	Valve Actuators	14
10.5.8	Wiring	14

10.5.9	Flow Measurement	14
10.5.10	Connection at the Mechanical Services Switchboard	15
10.5.11	Uninterruptible Power Supply (UPS)	15
10.6	SOFTWARE REQUIREMENTS	15
10.6.1	Capabilities	15
10.6.2	User Friendliness	16
10.6.3	Graphics	16
10.6.4	Software Versions	17
10.6.5	BAS Communications	17
10.6.6	Reporting	17
10.6.7	Trend Logging	18
10.6.8	BAS Alarms	18
10.7	BAS HARDWARE POINT REQUIREMENTS	19
10.7.1	General AHU	20
10.7.2	General FCU	21
10.7.3	General VAV	22
10.7.4	General Ventilation Fan	23
10.7.5	Kitchen Exhaust Fan	23
10.7.6	CHW / HHW pump	24
10.7.7	Fire Monitoring	24
10.7.8	Electrical Meter	24
10.7.9	Gas / Water Meter	25
10.7.10	Thermal Meter	25
10.8	BAS CONTROL STRATEGIES	25
10.9	CONTROLS CONTRACTOR REQUIREMENTS	26
10.10	SAMPLE SCHEMATIC DIAGRAMS	27
10.11	DESIGN CHANGE AUTHORISATION	31

10.1 INTRODUCTION

This section of the Design Standards provides details of the University's minimum requirements for the design, installation and operation of Building Automation System (BAS) services. The BAS contractor (or for larger building projects, the project consultant) is expected to produce their own detailed BAS specification incorporating the elements of the following information and to submit all designs to the University's Manager Engineering and Infrastructure (Campus Services) for review and approval prior to tendering the project and commencing any works on site.

Please read this section in conjunction with the rest of the Design Standards documentation.

10.2 GENERAL SYSTEMS AND STRATEGY

10.2.1 *Future Direction: The BAS Strategy*

The University's BAS Strategy aims to consolidate all existing and future BAS sub-systems into a central building management system to provide a single point of access for monitoring and control of all buildings across the Parkville campus. This centralised structure will provide the following operational benefits:

- A single point of access for monitoring and control of all buildings throughout the campus;
- More efficient servicing and system diagnosis;
- Remote access support for monitoring and control of any building from any location throughout the Parkville campus and from off-site locations; and,
- Access to all BAS systems via portable devices

The strategy is underpinned by a commitment that all systems / devices must comply with the open protocol of either the LON or BACnet IP communications standard. All DDC controllers must support open programming using software programming tools available to a number of local based Melbourne BAS contractors for ongoing support purposes. Where buildings have existing LON based BAS systems, it is required for new projects to install compatible LON controllers. However, for a significant building upgrade project, it may be considered a better solution to install BACnet controllers and to interface them with the existing LON based BAS network.

Furthermore, the University is committed to developing a centralised BAS management and support facility that allows technicians and operators to access any of the University's BAS systems from a central location or remotely via secure Internet access.

The following key outcomes are sought from implementing the BAS Strategy:

- Centralised BAS management tools, interface, reporting, trending, event and alarm logs;
- Remote web-access to all BAS systems;
- LON or BACnet IP-based controller communication protocol;
- A single point of access for control and monitoring of all buildings throughout the campus;
- Use of a common set of BAS / DDC products that support the LON or BACnet IP protocol and can be integrated onto the centralised BAS by our preferred BAS Services Contractor or selected BAS contractors;

- The capability to integrate other building sub-systems (i.e. lighting, fire, security, energy and water metering, etc.);
- The ability to implement energy efficient control strategies and functions such as time scheduling, load shedding, optimum start/stop, morning warm-up and night-purge, etc.);
- High level communication interfaces to VRV systems, chillers, VSD's, electrical metering and lighting control systems;
- Standardised alarm functionality integrated throughout the BAS with automatic alarm SMS paging and/or email notification to designated responsible persons for each area / system, as advised by the University;
- No obsolete products, devices, protocols or systems are to be installed; and,
- No proprietary systems are to be installed that would result in the University being dependent on a single organisation for ongoing support and maintenance.

To achieve these outcomes, the University has developed a three tier BAS Architecture to achieve the key outcomes identified above, as follows:

- Tier 1: Centralised BAS Management;
- Tier 2: Building Specific BAS Systems;
- Tier 3: Localised BAS / DDC controller devices that support LON or BACnet IP.

10.2.2 BAS Migration Plans

The following table summarises the range and extent of the different BAS systems currently in place at the University's Parkville Campus, together with comments regarding the future migration plans for each system type.

SYSTEM TYPE	MIGRATION STRATEGY
Tridium Niagara N4 using DGLux 5 graphical interface	Current controller products support the BAS strategy and includes the use of the Tridium expansion modules. DGLux 5 is the graphical interface tool used throughout The University of Melbourne.
Schneider Electric Structureware	Current controller products support the BAS strategy and the LON standard in specific buildings
IA Series Niagara R2	The University is phasing out this product range. All of these systems should be migrated over time to Tridium Niagara N4 current technology systems with a web interface.
Satchwell IAC / MN-FLO	These proprietary products communicate via a gateway. These products should be upgraded to LON or BACnet based VAV products.
Schneider Electric 'IA' Series	Current controller products support the BAS strategy and the LON standard.
Distech	Current controller products support the BAS strategy and the LON standard.
Stand Alone Controls	These products should be replaced with Tridium Niagara N4 current technology products during any repairs / upgrade / refurbishment works.

It is essential that any proposed refurbishment / upgrade project which is likely to impact on a current BAS installation must be discussed with and approved by the Engineering and Infrastructure Services team prior to any tender submission to ensure that the proposed works will comply with the University's BAS Strategy and will not compromise

/ conflict with an existing BAS installation and the relevant building's BAS migration / upgrade plan. The same applies to the design and construction of any new building.

10.3 AUSTRALIAN STANDARDS AND CODES

All BAS installations shall be designed, installed, tested and maintained in strict accordance with the most recent ratified publication of the following Australian Standards and Codes:

AS/NZS 3087.1.2003	Telecommunications Installations – Specification for the testing of balanced communications cabling
AS/NZS 3087.2.2003	Telecommunications Installations – Specification for the testing of patch cords
AS/NZS 3000:2007	SAA Wiring Rules
AS/NZS 3080.2003	Telecommunications Installations – Generic cabling for commercial premises
AS/NZS 3084.2003	Telecommunications Installations – Pathways and spaces in commercial buildings
AS 60529:2004	Specification for degrees of protection provided by enclosures (IP code)
AS 1668.1	Fire and smoke control in multi-compartment buildings
AS 1668.2	Ventilation design for indoor air contaminant control
AS 1668	The use of ventilation and air conditioning in buildings
ANSI/ASHRAE 135-2016 and 135.1-2013	BACnet data communications protocol (ISO 16484-5:2017) and Method of Test for Conformance
ISO/IEC 14908-1B & related standards	LonWorks data communications protocol
ANSI/ASHRAE 134-2005	Graphic symbols for HVAC and refrigeration systems
ANSI/ASHRAE GUIDELINE 1.1 2007	HVAC technical requirements for commissioning process
Modbus-IDA	Modbus Application Protocol Specification V1.1b3

10.4 GENERAL REQUIREMENTS

10.4.1 Point Schedules

For any BAS design, consultants shall provide comprehensive hardware point schedules detailing point descriptions, functions, types and any special requirements.

A copy of the 'As Built' revision points schedule shall be included in the BAS Operation & Maintenance manual for any BAS upgrade or new installation works and a hard-copy left in each field control panel.

Points schedules shall include, as a minimum, the point tag name, point description, point type (AI, DI, AO or DO), cable label, field device part number, field device description and comments columns.

10.4.2 **BAS Ethernet Networks**

Any new BAS installation shall be connected to the University IT department's Ethernet TCP/IP networks. The University has developed a three-tier BAS architecture, as follows:

- Tier 1: Centralised BAS management tools for campus-wide monitoring and control with remote web access capability via remote access to the University's Ethernet TCP/IP network;
- Tier 2: Local IP-based controller communication protocol between devices within individual buildings;
- Tier 3: Localised BAS / DDC controller devices that support LON or BACnet IP.

The Consulting Engineer shall liaise with the University's Engineering & Infrastructure team (Campus Services) on BAS design and requirements, and obtain information on the existing BAS systems before commencing the initial project design phase.

10.4.3 **LON & BACnet Open Communication Protocols**

The University intends to maintain and support existing LON based BAS controllers where installed. For refurbishment and building upgrade projects where there are existing LON based BAS controllers, it is desirable to install new compatible LON based controllers. However, for a significant building refurbishment project, it may be more cost effective to install BACnet controllers interfaced to the existing building BAS system. Any new installation must be capable of a full and transparent interface. All configuration files, bindings, graphics, etc. must be non-proprietary and able to be edited or amended by the University or its appointed BAS Installation Contractors / preferred BAS Services Contractor.

Proprietary type controller device communication protocols will not be accepted for any University project.

For further details, refer to the appropriate current LonMark or BACnet IP standards documentation.

10.4.4 **DDC Network Controllers**

All field network controllers are to support LON or BACnet network communications, as appropriate for the project. Most of the existing installed network controllers are Schneider UNC R2 LON type controller or Distech; for which the University holds a licenced copy of the software or has plug-ins for tunnelling to freely program and alter the existing programs. The UNC R2 network controllers are no longer to be installed at the University.

Proprietary type controllers with locked programming tools that are not available to any other Melbourne based BAS contractor or provided to the University as part of the project are not accepted for any University project.

The preference for new installations or replacement is:

- Tridium Niagara 8000 N4

The protocols at field level that are acceptable are;

- Non-propriety open licence Tridium Niagara N4 JACE 8 or greater
- A minimum of one unit per building.
- Either one JACE 8 be utilised per each floor of a building or a maximum of 120 field devices
- be connected to a single JACE.

- It is a requirement that each MSTP network is to serve a maximum of one floor.
- Additionally, all new JACE controllers must be licensed with Lon MSTP as a minimum.

In making modifications or additions to an existing JACE(s) the vendor is to ascertain whether the existing JACE(s) have the capacity to accommodate for new works. In the event that the existing JACE(s) are inadequate in handling the additional project works, the vendor must provide additional JACE(s) for new works unless otherwise specified or instructed. In the event of the overloading and causing of instability of JACE controllers, the vendor is to bear the costs of rectification the problem.

The vendor will be responsible for connecting the new project works onto the BMS network, arranging IP addresses, and all other related works. Under no circumstance will JACE(s) from other buildings be used in performing control functions, store trends, store graphics, and other related processes.

Any additional Lon system controllers or routers, to be installed, are acceptable but must communicate to the JACE(s) controlling the building.

The only software accepted for modification, setting up, commissioning, programming, editing, backing up or servicing any controllers is Tridium Niagara N4 Workbench.

All Workbench PC tools and software installed on JACEs to be compatible with the above version of Tridium Niagara N4.

Any project works carried out involving existing JACEs that do not meet the minimum version requirements are to be upgraded to the latest version at the cost of the vendor. Each vendor must provide the required modules for modification, setting up, commissioning, programming, editing, backing up or servicing the field controllers and install the modules into Tridium Niagara N4 Workbench.

The vendor working on the Tridium software must all be fully Tridium licenced and must be an authorised Tridium System Integrator.

Controls that require 3rd party tools outside of Tridium Niagara N4 AX workbench to modify, setup, commission, program, edit, backup or service shall not be deemed acceptable without prior approval from the Manager Engineering and Infrastructure. This specifically includes all 3rd party software that requires dongle.

10.4.5 DDC Field Controllers

All field DDC controllers are to support LON or BACnet network communications as appropriate for the project. Most of the existing installed controllers are Schneider I/A Series LON or Distech LON type controllers; for which the University holds a licenced copy of software to freely program and alter the existing DDC programs.

Any new LON or BACnet field controllers must support and have open programming tools allowing multiple Melbourne based other BAS contractors to be able to modify and install new programs. Programming tools are to be supplied and licensed to the University for any new controllers installed.

Proprietary type controllers with locked programming tools that are not available to any other Melbourne based BAS contractor or provided to the University as part of the project are not accepted for any University project.

The preference for new installations or replacement is:

- LON or BACnet Schneider I/A Series
- Distech EC range of controllers

The protocols at field level that are acceptable is LonMark TP/FT-10

It is not acceptable to install proprietary communications protocols or gateways to proprietary protocols without prior approval from the Manager, Engineering and Infrastructure.

Standard off the shelf, non-proprietary and openly programmable controllers that require individual licensing are not accepted without prior approval from the Manager Engineering and Infrastructure.

New systems will be capable of future expansion with spare capacity in memory and processing power and 20% spare Input / Output capacity.

All firmware updates and bugs to be upgraded throughout defect liability period at no additional cost. The field controller's system shall be compatible with future software and hardware updates.

10.4.6 High Level Interfaces (HLI's)

Any VRV or proprietary type air conditioning system or sub-system planned to be installed or upgraded as part of the BAS or any other building service, should be fitted with a LON or BACnet interface network device to support communication with the BAS system.

Chillers, VSD's, electrical metering and lighting controls are expected to have HLI's to the BAS.

Wherever possible, installation of native open LON or BACnet protocol devices is preferred.

10.4.7 BAS Spare Capacity

The network controllers and main plant DDC controllers are to be installed with both 20% minimum spare hardware and software capacity at the time of project practical completion.

Spare hardware capacity is defined as 20% minimum spare of each point type being analogue input, analogue output, digital input, digital output and totaliser type points, without adding any additional hardware modules.

Spare software capacity is defined as 20% spare for additional programming control loops and graphics from the accepted installed system, as at practical completion, to match future hardware points or further software strategies.

The front-end BAS software is to be licensed and capable to provide 20% spare point capacity, including trend and event logging from the installed system, as at practical completion, to allow for future system expansion.

10.4.8 BAS Product Support

All new BAS products and devices installed on projects must have a minimum of 10 years remaining product support from the manufacturer. The University may request written information from the manufacturer to confirm this support.

Products deemed within 2 years of the end of their product lifecycle are not to be installed.

10.4.9 Criteria for Connection to BAS

The following equipment is to be connected to the BAS, as a minimum (unless a project exception is agreed to by the University):

- Mechanical Equipment (chillers, boilers, fans, pumps, VSD's, AHU's, FCU's, VAV's, VRV's, etc.);
- Electrical Equipment (meters, power factor correction, UPS, etc). The University's preference for high level communication interfacing, and not low level pulse signals;
- Lighting Controls: The preference is for high level communication interfacing;
- Hydraulic Systems, including water metering;
- Access Control, as necessary;
- Fire System point monitoring, as necessary;
- Solar Equipment / Panels; and,
- Air Quality.

10.4.10 Safety

No combination or sequence of operations of the BAS control shall cause a condition which is unsafe, unhealthy or liable to cause damage to equipment.

Functionality which is essential for safe operation shall be mechanically interlocked. For example, the enabling of electric re-heat units via the BAS controller output shall be overridden by a hardwired interlock in the mechanical panel to prevent the electric re-heat from operating unless the hardwired interlock to that unit's air flow switch and / or other air-flow proving device is satisfied.

Appropriate delay times and run-on timers shall be incorporated, wherever required, to ensure dampers are open prior to fans starting, fans run-on following electric re-heat no longer required, etc.

10.4.11 Energy & Water Conservation

The BAS shall be capable of implementing sustainability energy management programs including:

- Time programmed start / stop;
- Optimum start / stops;
- Supply air temperature reset;
- Economy cycle;
- Lighting control where appropriate;
- Occupancy sensing, control and scheduling;
- Wide temperature band / load reset;
- CO and CO₂ sensing control for air quality;
- Variable pressure control strategies for air and water systems;
- Thermal energy calculation;
- Virtual energy/water meter calculation;
- Optimum plant operation. For example, ventilation to lecture theatres being controlled on air quality level. Occupancy sensors should be used where appropriate;

- Load shedding of gas and electricity consumption;
- Any other monitored points which may assist in producing energy saving or energy consumption statistics;
- Water, gas and energy consumption, demand and totalisation by day / week / month / year and associated reporting;
- Tenant billing ability;
- Advanced water, gas and energy automated reports, custom reports, forecasting, unusual event detection and alarming, historical data record and back-up, comparison between individual meters, buildings and/or historical records (e.g. last month versus same month of previous year, etc.);
- Calculation of CO₂ emissions based on user-adjustable emission factors, definable for each component of the energy used (i.e. ensure the consumption of zero carbon energy from alternate sources is not included in the calculation of total CO₂ emissions).

10.4.12 Motion Detector Equipment

Motion detectors should be connected to the building's BAS system to control lighting and air conditioning in the affected areas. Wider temperature dead band control and reduced air flow shall be incorporated into a standby mode function.

10.4.13 Temperature Monitoring

Space temperature sensors shall be installed in each air-conditioning zone as independently controlled by the heating / cooling system. In the case where a zone covers several rooms, sensors shall be installed in each room and the average temperature shall be used for temperature control.

A supply air temperature sensor shall be fitted to any heating / cooling coil including VAV boxes with reheats to provide the BAS with a status of the plant and equipment.

10.4.14 Status Monitoring

Equipment status shall be a means of accurate verification of actual air/water flow. For example, the status of fans and pumps shall be provided by differential pressure transmitters/switches rather than contactor auxiliary contact points or other voltage free contacts that may not be reliable in all scenarios. Should a fan belt break on belt driven equipment, the contactor status is not to be affected.

Sufficient statuses shall be provided to the controller to allow the behaviour of the system to be monitored and diagnosed. If the BAS controls a pump or a fan, it shall monitor the pump or fan status. If the BAS controls a chiller or a boiler, all other associated parameters (i.e. status, alarm, water flow and return temperatures, pump status, etc.) shall be monitored. The BAS shall provide a mismatch alarm from control and status points for "fail to start" and "running in manual".

Should the fire system override plant for emergency shutdown due to a fire alarm condition, this alarm shall be provided to the BAS controller as a status digital input, an alarm shall be raised on the BAS head-end and all associated alarms arising due to the fire override of plant shall be disabled to prevent nuisance alarms arising from the fire override condition.

10.4.15 Set Point Adjustments

Where appropriate for the design, safe and efficient operation of the plant, the BAS front-end graphics shall provide the ability to override the control setpoints of mechanical plant

provided all necessary conditions for setpoint reset are satisfied, as detailed in the BAS specification by the design consultant.

The BAS control shall prevent the override of set points beyond a reasonable range, as defined by the design consultant and/or plant manufacturer.

A temporary setpoint adjust needs to be provided for the mechanical contractors to temporarily override set points for a maximum of 1 hour.

Occupants of a space shall not be provided with the facility to vary the zone temperature set point locally.

10.4.16 Liaison

The Consulting Engineer shall liaise with the University's Engineering & Infrastructure team (Campus Services) on BAS design and requirements and obtain information on the existing BAS systems before commencing the initial project design phase.

10.4.17 Labelling

All items of equipment associated with the BAS shall be suitably identified with traffolyte or equivalent plastic labels. Front End, field controllers, VAV boxes, valves, dampers, and field sensors shall be labelled with identification that matches the relevant item programmed in the Front End.

All works shall be adequately documented so that every wire can be subsequently identified by wire number, colour code or termination frame location. All wires shall be numbered individually, and multi-core cables shall be terminated according to the standard colour code.

10.4.18 Commissioning

The BAS installation shall be fully commissioned and operational at the time of practical completion stage of the project. Commissioning procedures shall conform to Section 9: Mechanical Services and shall be carried out at the end / field equipment device to verify correct operation of equipment. All field sensors are to be calibrated against verified test instruments.

All sensors are to be calibrated and checked for correct operation. Dampers and valves are to be correctly stroked for 0%, 50% and 100% open positions.

Commissioning documentation is expected to be supplied to demonstrate that all BAS hardware and software has been fully commissioned including interfaces to other systems and devices.

All control loops must be fine-tuned to avoid valve actuators, damper motors and VSD speeds hunting for stable plant operation.

Commissioning of floor mixing boxes in conjunction with the mechanical contractor to calibrate airflow readings and implement commissioning airflow setpoints.

Undertake an air-conditioning system fire test in conjunction with mechanical contractor to ensure dampers and any VSD installation operates correctly for fire mode.

Fully configured graphical trend logs shall be required to be implemented for all equipment by the project BAS contractor to enable effective operational performance analysis and fine tuning during the commissioning phase.

All commissioning / test reports are to be provided to the University's Engineering and Infrastructure team (Campus Services) and design consultants for review.

10.4.19 Training, As-Built Drawings, Operating & Maintenance Manuals

The specification shall require the BAS Contractor to instruct and provide training to relevant University personnel and its nominated Contractors in the operation of the system prior to practical completion or project hand over.

As-built drawings, operating and maintenance manuals are to be provided as described in the CAD Standards Section of the University's Design Standards. The following BAS documentation is to be provided as a minimum:

- a) Communication network and controller architectural drawings;
- b) High level interface details;
- c) Description of Operation including all control strategies;
- d) Controller I/O hardware schedules including field device details;
- e) Configured IP addresses;
- f) Product data sheets for field sensors/devices; and,
- g) Maintenance schedules.

One electronic set is to be supplied to the University's nominated Project Manager in PDF format (via email) and on a USB memory stick.

Manuals also need to be accessible via a link on the BAS building home page.

10.5 HARDWARE REQUIREMENTS

10.5.1 Input / Output

All interfacing with control devices shall conform to the following standards:

- Binary input:
 - Voltage-free contact;
 - Pulse input.
- Binary output: voltage-free contact;
- Analogue input:
 - 0–10V, 0–5V;
 - 4–20 ma;
 - Current device sensor;
 - Resistance device sensor;
 - Voltage device sensor.
- Analogue output:
 - 0–10V, 2-10V;
 - 4–20 Ma.
- Service meters (gas, water, electricity): smart meter for electricity, gas and water consumption. HLI connection for electricity metering and pulse input connection for gas and water metering;
- Control relays shall operate at 24V AC; and,
- Other interfacing standards are only acceptable in unusual circumstances, where sensors and devices conforming to the above standards are not available.

10.5.2 Direct Digital Control (DDC) Controller

The Direct Digital Control (DDC) Controllers shall support LON or BACnet communications and be a completely independent stand-alone unit, with all firmware and software programs to maintain control on an independent basis in event of a network communications failure. The controllers shall have full open software programming capability that at least three Melbourne based BAS contractors can access and perform DDC program modifications.

The main AHU, chiller and boiler Plant Controllers shall be enclosed in metal powder coated IP54 rated panels or within dedicated spaces within mechanical switchboards.

The system shall allow various main controllers and sub-controllers to be networked and have the flexibility to readily permit software modifications and additions of the control functions. Should one controller in a network fail, it shall not affect the performance of any others.

10.5.3 Temperature Sensors

Temperature sensors shall be resistance, voltage or current device types with ranges selected to suit specific applications and have a repeatable accuracy of $\pm 0.3^{\circ}\text{C}$. Sensors shall be protected in a neat plastic or metal casing so that access to terminal strips and cabling can easily be achieved by removal of a cover. Sensors mounted on external walls shall be insulated with cable entry holes effectively sealed. Sensors shall be professionally labelled to indicate air-conditioning zone or sensor number.

Sensors shall not be locally adjustable. Where two or more sensors are provided for one zone, an average signal shall be used for temperature control.

Sensors shall be mounted such that effects of direct radiation from heating / cooling sources (e.g. direct sunlight, heat generating equipment, supply air duct discharge grilles, draughts, etc.) are minimised.

10.5.4 Pressure Switches

Pressure switches shall have adjustable ranges and adjustable differentials to suit the application.

Pressure switches shall be sensitive enough (as low as 20 Pa if necessary) to ensure correct monitoring of small fans and shall have a switching differential of not more than 10% of the scale range;

Substitute the use of a pressure switch in favour of a current transformer with voltage free contact for status monitoring of very small fans where the duct pressure is unlikely to exceed the minimum sensible pressure.

10.5.5 Pressure Sensors

- Shall be suitable for the sensing medium, operating temperatures and pressures;
- Shall be capable of withstanding a hydraulic test pressure of 1.5 times the normal working pressure;
- Connections shall be suitable for 8mm (¼") o.d. copper tube or poly tube for air connections;
- Ductwork versions shall be supplied with air connections permitting their use as static or differential pressure sensors; and,
- The setpoint shall fall within 30%-70% of the sensing range of the sensor.

10.5.6 Damper Actuators

- Control voltage shall be 0–10V DC and power supply shall be 24V AC;
- Shall have sufficient drive torque to open and close valves against the maximum out of balance pressure across them;
- Dampers shall incorporate spring return facility, wherever necessary, for fail-safe operation during fire mode or in the event of power failure;
- Mounting shall be rigid without distortion during operation. Linkages shall be fixed to shafts with grub-screws set in drilled recesses;
- Dampers shall be supplied complete with the necessary universal joints, cranks, linkages and mountings for the specified motorised damper; and,
- Dampers shall have position indicators unless fitted to terminal units. The fully open and closed positions shall be unambiguously marked.

10.5.7 Valve Actuators

- Control voltage shall be 0–10V DC or 24 volt AC floating and power supply shall be 24V AC;
- Valve actuators shall be linear in operation fitted with a manual override such that, in the event of a power failure, manual operation can be achieved;
- Valve actuators shall have sufficient drive torque to open and close control valves against the maximum system pressure;
- Valve actuators shall be supplied complete with the necessary universal joints, cranks, linkages and mountings for the specified motorised valve; and,
- Valve actuators shall have position indicators unless fitted to terminal units. The fully open and closed positions shall be unambiguously marked.

10.5.8 Wiring

The wiring for data communication between sensors, controllers, valve / damper actuators and any other BAS analogue or digital signals shall be shielded so as to not be susceptible to any electromagnetic interference such as electrostatic, magnetic, mode and cross talk noise. Cabling is to have suitable sized conductors to minimise voltage drop at devices.

All cabling shall be routed at least 500mm away from any low or high voltage power wiring and cross-over at right angles where required (no parallel runs).

Orange CAT5e communications cabling shall be used for all BAS communications wiring.

Orange CAT5e patch leads are preferred by the University's IT Section.

All other wiring shall conform to the requirements of Section 7: Electrical Services.

10.5.9 Flow Measurement

Flow measurement devices shall include differential pressure transmitter / orifice plates, turbines, electromagnetic flow meters, ultrasonic flow meters, probe air velocity sensors or grid matrix air velocity sensors.

All flow measurement devices shall be calibrated during commissioning by calibrated independent equipment and appropriate scaling, offsets and/or K-factors applied to the measured values accordingly.

All calibration data including K-factors and offsets shall be documented and incorporated in the Operation & Maintenance Manual for the BAS.

10.5.10 Connection at the Mechanical Services Switchboard

Controls shall be designed so that the equipment will work safely and without risk to University staff or property in the event of loss of power from a BAS controller.

Control cabling shall be wired to mechanical switchboards in conduits, cable trays or enclosed ducts and be terminated to control interface terminal strips provided in each board.

Control Auto-Off-Manual switches are to be front panel mounted on all Mechanical Services switchboards. These switches shall conform to the University's standard, and shall be provided with LED indicator lamps as follows:

- RED: ALARM, or equipment in FAULT
- GREEN: equipment switched ON (either manually or remotely)

In general, controllers shall be segregated, but close to a mechanical services switchboard which shall supply the necessary power to the controller. Note: all cabling passing through a mechanical services switchboard shall conform to appropriate standards (e.g. 500V insulation), but the controller shall be limited to extra low voltages (less than 35V), and data cable shall be rated accordingly.

10.5.11 Uninterruptible Power Supply (UPS)

For critical building operation, as per the consultants' design, the BAS is to be supported with an uninterruptible power supply (UPS) which must be capable of sustaining power to the controllers and associated devices for a minimum period of thirty (30) minutes.

The BAS shall be of the type that in the event of mains failure the equipment supported shall not power down and reboot.

The system shall incorporate sealed batteries and include alarm volt free contacts for connection to the BAS for monitoring of "UPS fault", "low battery" and "charger fault".

10.6 SOFTWARE REQUIREMENTS

10.6.1 Capabilities

The BAS controller software shall perform the following functions:

- Time schedule start / stop;
- Optimum start / stop;
- Duty / standby cycling;
- Lead / Lag staging;
- Automatic temperature control;
- Maximum demand control;
- Control mode selection (i.e. P, PI or PID);
- Calculation points;
- Run hours totalisation;
- Lighting control;
- Integration with scheduling programs (where applicable);

- Integration with metering devices;
- Scanning and alarm processing;
- Alarm functions (via SMS and email);
- Load shedding;
- Temperature set point reset algorithm;
- Night purge, warm-up mode, etc.;
- Graphics reporting;
- Trend logging (graphical);
- Global communication (including web functionality and remote access);
- OPC server compliance;
- Tenant billing;
- Energy reporting; and,
- Auto controller restart in event of power failure.

10.6.2 **User Friendliness**

The BAS front-end software shall be easy to operate and program. Operators should be able to perform the following operations after minimal training:

- View building parameters;
- Select relevant graphical pages, building systems and points;
- Acknowledge alarms;
- Turn on and off controlled points manually;
- Modify setpoints;
- Log trend data;
- Generate custom reports;
- Understand system performance;
- Understand device communication failures/alarms.

10.6.3 **Graphics**

The University of Melbourne standard graphics package is DGLux5.

DGLux5 is a multiple-deployment, drag-and-drop interface application accessible in browsers with HTML5. Using DGLux5 enables the following features to input the University's graphics standard:

- Animated widgets, background themes, patterns, effects, 3D equipment images and assorted icons
- Customisable charts & gauge components
- Tables with data formatting, calculations and transformation
- Create custom interactions by adding behaviours to any object
- Set mouse and touch screen gestures and behaviours for desktop, tablet and mobile smart devices using Intelligent scaling with responsive layout to create once for all devices.

The Graphics pages reside on the Tridium Niagara N4 Supervisor for the building. Standard status effect colours are:

- Communications Error Yellow
- Fault Orange
- Alarm Red
- Manual Purple
- Enabled Green

As part of the standards the graphics shall include:

- Building graphics with selectable floor buttons that highlight red when building has an alarm.
- Floor plan graphics with room that highlight red when building has an alarm.

Two levels of plant graphics with the first graphic showing BMS information about the plant to easily identify problems and a more detailed view accessible or popup to show more detailed information about specific plant.

No Vendor branding is to appear on any graphics pages.

Provide a link from the main graphic page to access the functional description related to that building.

10.6.4 Software Versions

The latest BAS software shall be installed at time of project practical completion.

10.6.5 BAS Communications

Any BAS system installed on University properties shall provide reliable user interface functions to responsible staff via the University's IT computer network. This will allow the relevant staff to:

- Access buildings from the central BAS front-end or via secure internet connection;
- Receive SMS alarm messages for critical alarm conditions; and,
- View building live and historical trend data from the central BAS front-end or via secure internet connection.

Within each of the particular networks, controllers shall have the ability to broadcast data, transmit input/output points as global points onto the network for use by other controllers to capture data for internal processing. If one controller fails, it shall not affect the other controller's performance

Any device communication failures shall raise a critical alarm on the BAS head-end.

10.6.6 Reporting

The BAS shall be capable and configured to produce the following reports to be viewed on the BMS screen, printed or exported to Microsoft *Excel* format. These configured reports are easily accessed from the main menu with selectable time/date start and end report durations and single point or multiple group point type or label selections.

A standard suite of reports is to be configured and provided for operator access including:

- Points in manual or override report:
 - Detail of points that have been operator overridden.
- Operator changes report:
 - Detail of what operator changes have been made. Single operator or all operator selectable.

- Point disabled or off scan report:
 - Detail of which points are not communicating or have been disabled from updates values to the front-end.
- Alarm event report:
 - Detail of alarms or point state change for a single point, group of points or all points.
- BMS controller or communications report:
 - Detail of communications alarms and controller diagnostic alarms.
- After Hours A/C report:
 - Detail of floor afterhours air-conditioning usage on a floor by floor basis with date and time stamping.

Reports are to include advanced water, gas and energy automated reports, custom reports, forecasting, unusual event detection and alarming, historical data record and back-up, comparison between individual meters, buildings and/or historical records (e.g. last month versus same month of previous year, etc.).

10.6.7 Trend Logging

The BAS shall have the ability to store logged data, including all input/output points, for a minimum period of two years online without manual data handling. Trend data must be easily retrievable for export to Excel spreadsheet.

Each point shall have individual time scales for system reporting. The time scale shall be adjustable in one minute increments.

The BAS software shall display live and historical trend data on demand.

The software shall allow the operator to select points, groups of points, and mechanical systems through user friendly graphics functionality.

It shall also be possible to register the start / stop sequence of any selected plant using the trend log, such as: main plant, floor / zone manager, services settings, water temperatures, etc.

Trend logging functions should be easy to query, manipulate trend periods, and adjust from the same graphics page.

The system shall have the facility for printing any display trend log.

All logs are to be stored for a minimum of 12 months.

10.6.8 BAS Alarms

Whenever abnormal conditions arise, alarms shall be generated and the alarm messages shall be displayed on the BAS head-end alarm log and simultaneously generate SMS and email messages, as appropriate to the application.

When an alarm condition is generated, the relevant head-end terminals on the system shall beep continuously until the alarm is acknowledged at any terminal.

The BAS shall prioritise alarm groups. Critical alarms shall be sent to nominated Asset Services Department staff for immediate action via SMS and email.

All devices and third party equipment shall be configured such that the BAS 'alarm' or 'fault' contact is in the alarm condition upon loss of power at the device/equipment.

A minimum of 3 levels of alarming is to be configured, as being "Urgent", "High" and "Low" priority or similar.

All alarms are to be event logged within the front-end database where applicable where a BAS database front-end is installed or the main network controllers where a front-end is not installed.

Change of state monitoring events for equipment on / off status are to be event logged within the front-end database.

Access for operator event report data retrieval is required for reporting.

The following alarms are to be configured as a minimum:

Urgent Priority Alarms

- AHU fan fail to start
- Return air fan fail to start
- Controller communications fail
- Fire GFA alarm
- UPS alarm
- Chiller common fault
- Boiler common fault
- High CHW flow temp
- Low HHW flow temp
- Hydraulic fault
- Pump fault
- Cooling tower fan fault

High Priority Alarms

- VSD common fault
- Low static pressure
- High CO
- High CO₂
- FCU fan fail

Low Priority Alarms

- Temperature alarms if 3 degrees above or below setpoint when associated plant is operating. Time delay of 30 minutes to be configured for temperature alarms.
- Filter alarms

Alarm conditions are to be clearly indicated on associated front-end graphic pages.

10.7 BAS HARDWARE POINT REQUIREMENTS

The University has a standard template of BAS monitoring and control points required for any typical new plant for consistency in building operations and control.

The University or design consultants may choose additional points beyond the standard template requirements depending on the type of project.

10.7.1 General AHU

Inputs

Description	Device	Point Type
Room zone temperature (may have multiple zone temperatures depending on project requirements)	Room temperature sensor	AI
AHU supply air temperature	Duct temperature sensor	AI
AHU return air temperature	Duct combination temperature	AI
AHU return air CO ₂	Duct probe CO ₂ sensor	AI
AHU supply air static pressure	Duct probe air pressure sensor	AI
AHU return air static pressure	Duct probe air pressure sensor	AI
AHU supply air fan status	Air differential pressure switch	DI
AHU filter pressure	Air differential pressure sensor	AI
AHU return air fan status	Air differential pressure switch or current switch for direct drive fans	DI
After Hours push buttons (project specified)	Room pushbuttons	DI
AHU supply air fan VSD fault	From VSD	HLI
AHU return air fan VSD fault	From VSD	HLI
AHU supply air fan VSD kW	From VSD	HLI
AHU return air fan VSD kW	From VSD	HLI
AHU supply air fan VSD kWh	From VSD	HLI
AHU return air fan VSD kWh	From VSD	HLI
Outside air temperature	Typically from building common sensors	Controller software transfer
Outside air humidity	Typically from building common sensors	Controller software transfer

Outputs

Description	Device	Point Type
AHU supply air fan start/stop	Low level wired to mech board	DO
AHU return air fan start/stop	Low level wired to mech board	DO

AHU supply air fan VSD speed	Low level wired to VSD	AO
AHU return air fan VSD speed	Low level wired to VSD	AO
AHU chilled water valve	Control actuator and matched valve	AO
AHU heating water valve	Control actuator and matched valve	AO
AHU outside air damper	Damper actuator	AO
AHU return air damper	Damper actuator	AO
AHU spill air damper	Damper actuator	AO
AHU bypass damper (If fitted)	Damper actuator	AO

10.7.2 General FCU

Inputs

Description	Device	Point Type
Room zone temperature (may have second zone temperature depending on project requirements)	Room temperature sensor	AI
AHU / FCU supply air temperature	Duct temperature sensor	AI
AHU / FCU return air temperature	Duct combination temperature	AI
AHU supply air static pressure	Duct probe air pressure sensor	AI
AHU return air static pressure (if R/A fan fitted)	Duct probe air pressure sensor	AI
AHU supply air fan status	Air differential pressure switch	DI
AHU filter pressure	Air differential pressure sensor	AI
AHU return air fan status (if R/A fan fitted)	Air differential pressure switch or current switch for direct drive fans	DI
AHU supply air fan VSD fault	From VSD	HLI
AHU return air fan VSD fault (if R/A fan fitted)	From VSD	HLI
AHU supply air fan VSD kW	From VSD	HLI

AHU return air fan VSD kW (if R/A fan fitted)	From VSD	HLI
AHU supply air fan VSD kWh	From VSD	HLI
AHU return air fan VSD kWh (if R/A fan fitted)	From VSD	HLI
Outside air temperature	Typically from building common sensors	Controller software transfer
Outside air humidity	Typically from building common sensors	Controller software transfer

Outputs

Description	Device	Point Type
AHU supply air fan start / stop	Low level wired to mech board	DO
AHU return air fan start / stop (if R/A fan fitted)	Low level wired to mech board	DO
AHU supply air fan VSD speed	Low level wired to VSD	AO
AHU return air fan VSD speed (if R/A fan fitted)	Low level wired to VSD	AO
AHU chilled water valve	Control actuator and matched valve	AO
AHU heating water valve	Control actuator and matched valve	AO
AHU outside air damper	Damper actuator	AO
AHU return air damper (if fitted)	Damper actuator	AO
AHU spill air damper (if fitted)	Damper actuator	AO

10.7.3 General VAV

Inputs

Description	Device	Point Type
Room zone temperature (may have second zone temperature depending on project requirements)	Room temperature sensor	AI
VAV supply air temperature (if reheat coil is fitted)	Duct temperature sensor	AI

VAV velocity sensor	Duct probe air pressure sensor	AI
---------------------	--------------------------------	----

Outputs

Description	Device	Point Type
VAV damper	Damper actuator	AO
VAV heating water valve (if fitted)	Control actuator and matched valve	AO

10.7.4 General Ventilation Fan

Inputs

Description	Device	Point Type
Fan status	Air differential pressure switch or current CT	DI
Room temperature (if fan is temperature controlled)	Room temperature sensor	AI
Fan VSD fault (if VSD fitted)	From VSD	HLI
Fan VSD Kw (if VSD fitted)	From VSD	HLI
Fan VSD kW (if VSD fitted)	From VSD	HLI

Outputs

Description	Device	Point Type
Fan start/stop	Low level wired to mech board	DO
Fan VSD speed (if VSD fitted)	Low level wired to VSD	AO

10.7.5 Kitchen Exhaust Fan

Inputs

Description	Device	Point Type
Fan status	Air differential pressure switch	DI
Local control switch	Pushbutton or control switch	AI
Duct pressure (if VSD fitted)	Differential air pressure sensor	AI
Fan VSD fault (if VSD fitted)	From VSD	HLI
Fan VSD Kw (if VSD fitted)	From VSD	HLI
Fan VSD kW (if VSD fitted)	From VSD	HLI

Outputs

Description	Device	Point Type
Fan start / stop	Low level wired to mech board	DO
Fan VSD speed (if VSD fitted)	Low level wired to VSD	AO

10.7.6 CHW / HHW pump**Inputs**

Description	Device	Point Type
Pump status	Water differential pressure switch	DI
Field differential pressure	Water differential pressure sensor	AI
Pump VSD fault (if VSD fitted)	From VSD	HLI
Pump VSD Kw (if VSD fitted)	From VSD	HLI
Pump VSD kW (if VSD fitted)	From VSD	HLI

Outputs

Description	Device	Point Type
Pump start / stop	Low level wired to mech board	DO
Pump VSD speed (if VSD fitted)	Low level wired to VSD	AO

10.7.7 Fire Monitoring**Inputs**

Description	Device	Point Type
Zone fire alarm for each zone	From Mech board	DI
General fire alarm	From Mech board	DI

10.7.8 Electrical Meter**Inputs**

Description	Device	Point Type
Red phase volts	From electrical meter	HLI
White phase volts	From electrical meter	HLI

Blue phase volts	From electrical meter	HLI
Red phase amps	From electrical meter	HLI
White phase amps	From electrical meter	HLI
Blue phase amps	From electrical meter	HLI
3 phase kW	From electrical meter	HLI
3 phase kWh	From electrical meter	HLI
Power factor	From electrical meter	HLI

10.7.9 Gas / Water Meter

Inputs

Description	Device	Point Type
Gas / Water meter pulse	From gas / water meter pulse interface	Totaliser

10.7.10 Thermal Meter

Inputs

Description	Device	Point Type
Supply water temperature	From thermal meter	HLI
Leaving water temperature	From thermal meter	HLI
Flow rate	From thermal meter	HLI
Thermal kW	From thermal meter	HLI
Thermal kWh	From thermal meter	HLI

10.8 BAS CONTROL STRATEGIES

The University has a standard template of high level BAS control strategy requirements for any new typical plant for consistency in building operations, control and energy efficiency.

A general summary of the standard control strategy requirements are as follows:

- Average zone temperature control based on supply air temperature reset strategy;
- Wide temperature dead bands for 20.5 to 24.5. degree room temperature control;
- CO2 monitoring for indoor air quality for outside air damper control;
- Chiller outside air temperature lockout;
- Boiler outside air temperature lockout;
- Chilled water temperature reset;

- Heating water temperature reset;
- Variable AHU static pressure control for VAV systems;
- Variable AHU supply airflow based on zone temperatures for non VAV systems;
- Variable CHW/HHW pumping based on pressure reset;
- Motion sensor monitoring for theatre, meeting & lecture rooms to provide a standby control mode with reduced fan speeds and wider temperature control;
- After Hours pushbuttons in areas likely to be used inconsistently for operating business hours;
- Upon a mismatch of a fan control and fan status, a fan start fail or fan running in manual alarm shall be generated after a delay period of 1 minute;
- Upon zone temperatures greater than 3 degrees from setpoint for a period of 30 minutes generate a high priority alarm on the BAS front-end if relevant plant is operating in time schedule hours;
- Generate a dirty filter alarm when the filter pressure drop reading is above a default setpoint of 250pa for a period of 2 minutes;
- The BAS shall mimic the mechanical switchboard fire controls and fully close/open outside and spill air dampers and control fan speeds based on the specified project fire matrix; and,
- SMS alarming for critical plant alarms.

10.9 CONTROLS CONTRACTOR REQUIREMENTS

Only a person experienced with the installation and maintenance of the equipment and software proposed shall install the system as to ensure that the entire system can interface seamlessly.

Each technician from the vendor is required to have completed training prior to performing any works on the controls they are using. Vendors working on the Tridium Niagara N4 software must be Tridium licensed and an authorised Tridium System Integrator.

10.10 SAMPLE SCHEMATIC DIAGRAMS

Niagara 4 Topology

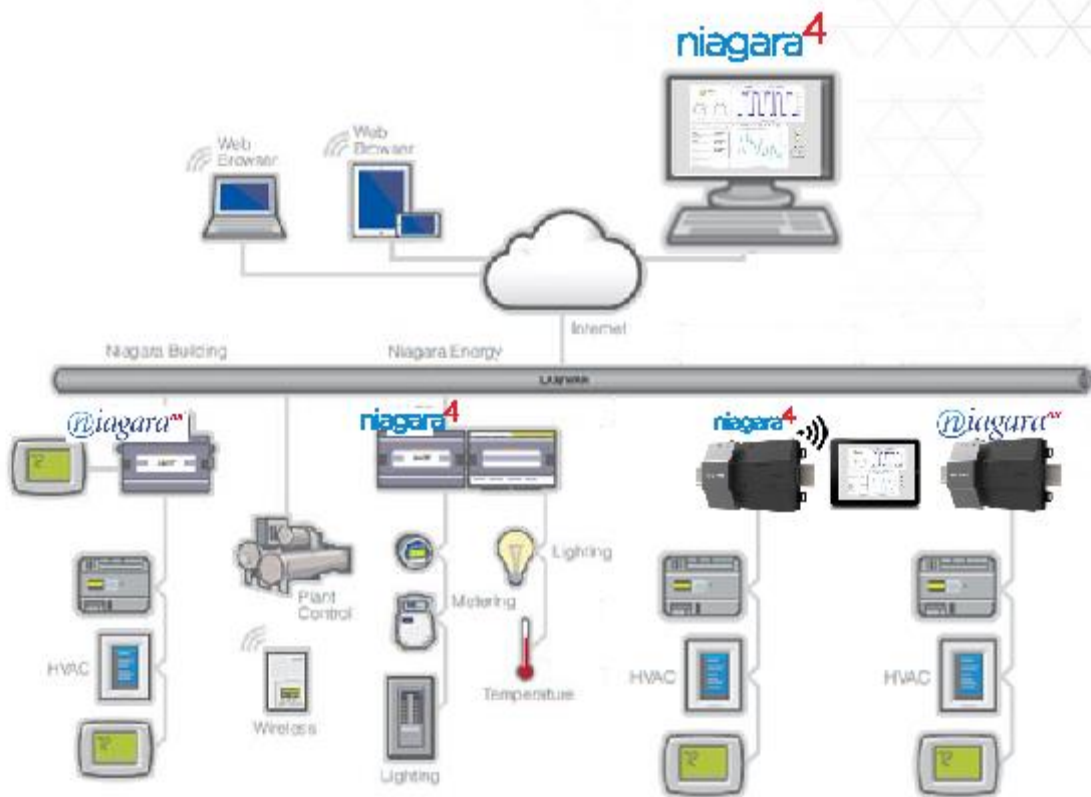

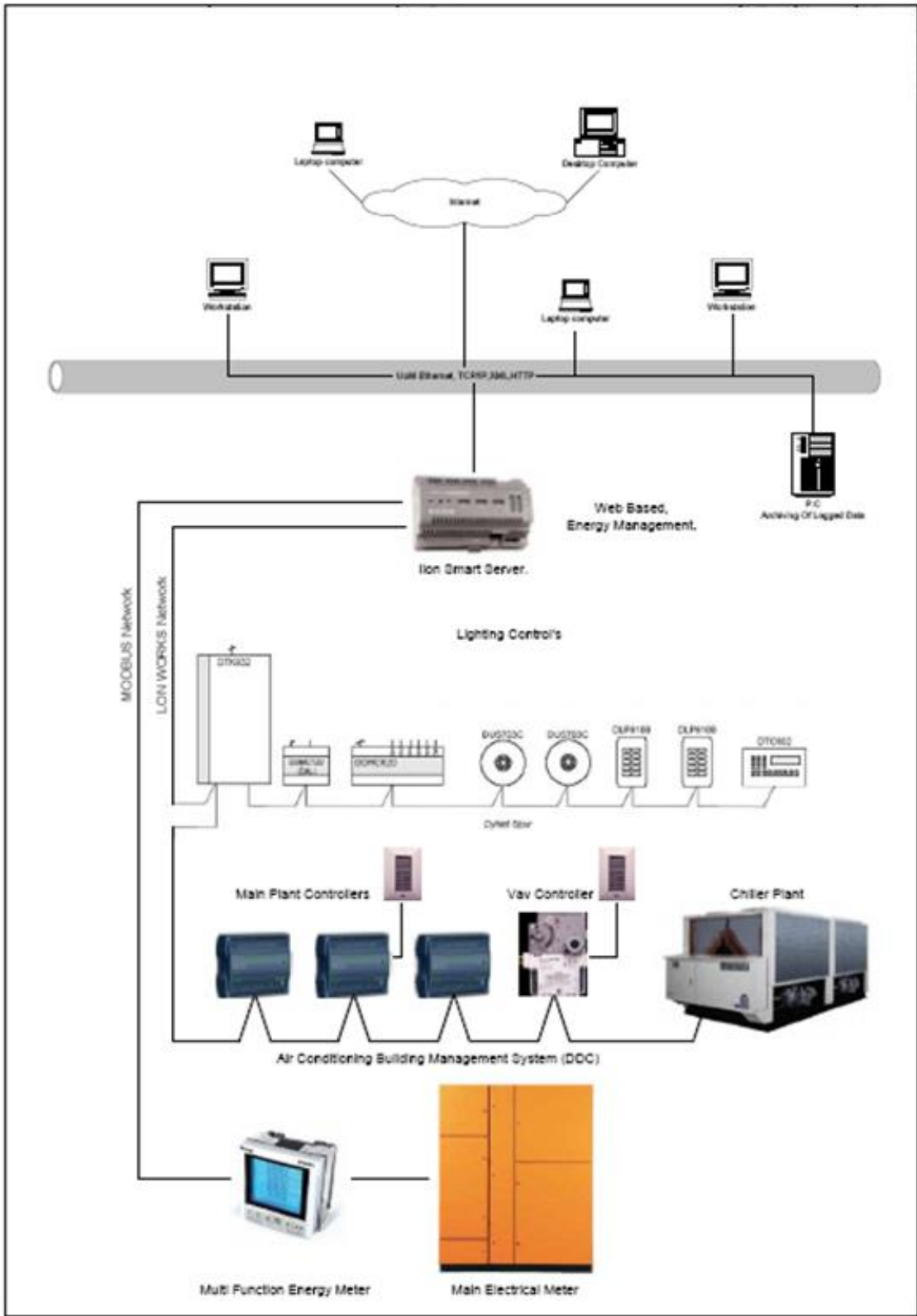

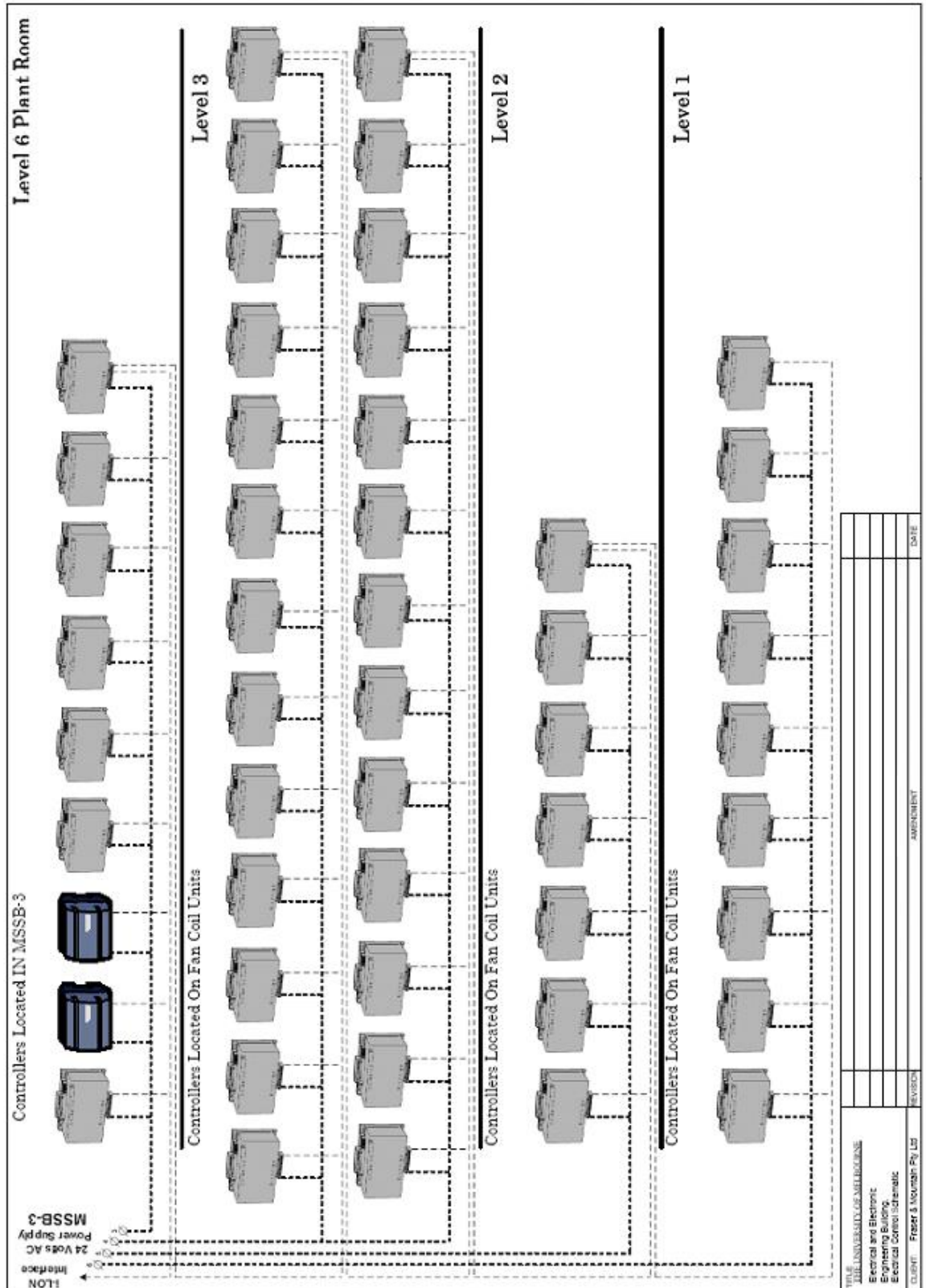

10.11 DESIGN CHANGE AUTHORISATION

All requests for changes to the requirements of the Design Standards must be made on the Modification Request Form. No design work is to proceed on the basis of the proposed modification until the modification request has been approved in writing.

SECTION 11: VERTICAL TRANSPORT CONTENTS

11.1	INTRODUCTION	3
11.2	LEGISLATION, STANDARDS AND CODES	3
11.3	LIFT DESIGN	3
	11.3.1 Objectives	3
	11.3.2 Lift Design	3
	11.3.3 Design Criteria	4
	11.3.4 Traffic Analysis	4
	11.3.5 Lift Control Systems	5
	11.3.6 Lift Types	6
	11.3.7 Lift Interior Finishes	6
	11.3.8 Lift Appointments	7
	11.3.9 DDA Requirements	9
	11.3.10 Car and Landing Doors	10
	11.3.11 HLI Access Control Security	10
	11.3.12 Emergency Communication System	10
	11.3.13 Lift Well	10
	11.3.14 Lift Well Access	10
	11.3.15 Electromagnetic Compatibility	10
	11.3.16 Lift Monitoring	11
	11.3.17 Lift Machine Room Design Requirements	11
	11.3.18 Machine-Room-Less (MRL) Requirements	11
	11.3.19 Ride Quality and Acoustic Treatment	12
	11.3.20 Lift Contractor List	12
	11.3.21 Energy Considerations	12
	11.3.22 List of Required Drawings	12
	11.3.23 As-Built Documentation, Manuals and Related Information	13
	11.3.24 Maintenance Records	13
11.4	BUILDING MAINTENANCE UNIT DESIGN	14
	11.4.1 Applicable Standards	14
	11.4.2 Design Objectives	14
	11.4.3 BMU Installation and Operation	15
	11.4.4 As Installed Equipment Label	15
	11.4.5 List of Required Design Information	15
	11.4.6 As-Built Documentation, Manuals and Related Documentation	16

11.4.7	Maintenance	16
11.4.8	Maintenance Records	16
11.5	DESIGN CHANGE AUTHORISATION	16

11.1 INTRODUCTION

The section of the Design Standards provides details of the University's minimum requirements for vertical transportation.

The consultant is required to produce his own project specification which incorporates this section and other sections of the Design Standards as well as all relevant legislation, regulation, codes and standards.

Note that the consultant must use the Modification Request Form to obtain approval for any proposed departure from the Design Standards.

All project documentation is required to be submitted for review prior to tendering.

11.2 LEGISLATION, STANDARDS AND CODES

The design of the lift systems shall meet the requirements of all current regulations and the requirements of the Authorities having jurisdiction over the project.

The lift system shall be designed and installed in accordance with the following Standards, codes and regulations:

- Occupational Health and Safety Act 2004 (Vic)
- Occupational Health and Safety Regulations 2017 (Vic)
- National Construction Code of Australia (NCC);
- AS1735.1 incorporating:
 - EN81.20 – Safety Rules for the Construction and Installation of Passenger & Goods Lifts.
 - EN81.50 – Safety Rules for the Construction and Installation of Lifts – Examinations and Test
 - EN 81-28:2003 - Remote Alarms on Passenger and Goods Passenger Lifts.
- AS1735.2 (Obsolescent) – Applicable sections as required as reference guide.
- AS3000 Wiring Rules;
- AS1735.12 – Facilities for People with Disabilities;
- Disability Discrimination Act

The lift designer shall also design vertical transport systems using a Safety in Design principle.

11.3 LIFT DESIGN

11.3.1 Objectives

Vertical Transportation Services designed for the University of Melbourne shall be based on appropriate educational institution and commercial design standards and good engineering practices. The lift installation, duty and speed shall be designed to assist with the efficient circulation of students and staff during the peak operating “class change” period, where up to 50% of the student population could require vertical transportation.

11.3.2 Lift Design

The lift designer shall adopt the following when designing the lifts:

- Passenger lifts shall be wider than they are deep to allow for the ease of passenger movement into and out of the lift car. Minimum passenger lift car size shall be W1600mm x D1400mm. Note that the stretcher requirements of the NCC shall be met where required;
- If a dedicated goods lift is not being provided a ceiling boot giving a clear internal height of at least 3m shall be provided in at least one of the lift cars. Where a passenger lift is fitted with a boot for goods service, protective blankets shall be provided to protect the interior finishes;
- A dedicated goods lift shall be considered for buildings requiring specialist goods movement. Goods lifts shall be designed with the appropriate load levels as required by the University including platform point loads and car and landing sill load requirements. Class C goods lifts as defined in AS1735.2 shall be nominated where heavy loading conditions may apply and/or where fork lifts or loading systems are used to load the lift;
- When planning the location of the lift or lift bank architects shall ensure the lifts are central relative to the building's circulation and are easily identifiable to assist in way finding.

11.3.3 Design Criteria

The vertical transportation design and architectural design of a building must complement each other to provide an efficient lift system design that is based on the following Key Performance Indicators:

- Waiting Interval – 30 – 50 seconds based on theoretical two-way study
- Handling Capacity – 15 - 25% of building population
- TEFMA, Best Practice, Space Planning Guidelines
- CIBSE Guide D – Transportation Systems in Buildings. Lift Planning and Selection, Universities and Education Buildings.

To maximise the effectiveness of the vertical transportation it is recommended that building design complements the lift design by designing buildings in zones. This may depend on the available space and accessibility requirement but where possible the recommended zones are:

- Lecture halls and class rooms located in the lower part of the building (large population movement).
- Labs located in the mid-section of the building (moderate population movement).
- Administration and staff located in upper-section of the building (low population movement).

11.3.4 Traffic Analysis

Where floors are designed for populations of 100 persons or more and requiring a bank of lift over at least 4 floors, a traffic analysis shall be provided to demonstrate the suitability of the lift design. Where necessary simulation studies shall be provided to the University Project Manager to review and consider.

Waiting Interval and Handling Capacity criteria range shall be based on the 10 – 15 minute student and staff movement between lectures. The parameters upon which the lift traffic analyses shall be based, are as follows:

- a) Waiting Interval is defined as the time a passenger waits after registering a call (or entering the waiting queue if a call has already been registered) until the responding lift departs that floor

- b) Handling Capacity (HC) is the percentage of the given building population wanting to use the lifts in a 5 minute period.
- c) Estimated division of student and other traffic during a 5 minute period:
 - 35% lift users enter the building
 - 35% lift users exit the building
 - 30% lift users travel between floors
- d) Stair factor is considered where the stairs are clearly visible and accessible from the lift lobby. Stair factor - ranging between 20% to 50% of potential lift users over a range of floors e.g. 1 floor 50%, 2 floors 25%, 3 floors 15% etc
- e) Home floor – Typically Ground
- f) Door dwell time – 1.0 second
- g) Door Open and Door Close times – 2.8 seconds and 3.4 seconds
- h) Passenger Loading Time – 1.0 second in and 1.0 second out
- i) Acceleration/deceleration – 1.0 m/s²
- j) Start Delay – 0.5 seconds

11.3.5 Lift Control Systems

As a minimum all lifts shall operate on the principal of a two button collective control system having at least the following features.

- Exclusive service;
- Fireman's service, as per the requirements of AS1735;
- Load-weighing control;
- Door nudging system;
- Anti-nuisance feature;
- Emergency Power for lighting and phones;
- HLI Access control provisions, applicable where access control is provided to the lift.

Where applicable lift group control systems shall be high speed micro-processor and software based and incorporate the latest proven demand based traffic management algorithms to optimise system response times and operating/energy efficiencies.

It is a particular requirement of the University that all equipment be of a non-proprietary (open architecture) nature. Equipment requiring proprietary service tools or user guides/codes will not be accepted unless a Modification Request Form is submitted and approved.

The lift system shall incorporate a software protocol that allows the maintenance, servicing, tuning and adjustment of the equipment by third party service providers. The lift system hardware and software shall be provided so that the complete installation is capable of continuous unrestricted operation from the date the lift becomes the property of the University and for the life of the installation. The system must be capable of being readily maintained and adjusted on site, without the need for the use of codes, locks, external devices, external information, re-activation sequences, or the like.

Where any form of diagnostic tool is required to diagnose the lift equipment and where such a tool is required to re-program replacement components, a tool shall be provided for the exclusive use of the University for ongoing maintenance of the lift.

Drive systems shall be permanent magnet VFAC drives. Preferably of the high efficiency gearless type.

Where stand-by power is being provided to the building consideration shall be given to operating at least one lift to assist in the movement of people with disabilities.

11.3.6 **Lift Types**

When selecting the type of lift to be used the following lift types are to be considered:

- Machine Room-Less (MRL) lifts;
- Conventional overhead lift motor room traction lifts;
- Hydraulic lifts shall not be considered unless required for a particular problem-solving application or where MRL lifts cannot be provided;
- Disabled platform lifts in accordance with AS1735.14 or 16. These are only to be used for short rise very low use applications only;
- Where possible and appropriate lifts which are being refurbished shall be provided with regenerative drives.
- New building projects shall include a requirement for regenerative drives.

The lift designer is required to support the lift selection with a whole life (20 years) cost analysis and present this to the University Project Manager. The costs analysis shall include an indicative cost breakdown of the whole lift costs of the life as per the following:

- Power consumption, machine and control system efficiency;
- Consumable items, such as ropes, sheaves, bearings, guides, etc;
- Expected cost for comprehensive maintenance.

11.3.7 **Lift Interior Finishes**

Lift interior finishes shall be robust, low maintenance and vandal resistant. When designing a lift car interior, the following should be considered:

- The layout of the car shall meet the requirements of AS1735.12;
- Wall finishes shall be durable. Consideration should be given to the use of the lift and the environment that it will operate in.
- Car operating panels (COP) shall generally be provided on the side walls, mounted in a vertical alignment and compliant to AS1735.12;
- Handrails shall be provided adjacent to the main COP in compliance with AS1735.12.
- Lift display screens shall generally be provided in the COP;
- Lift car flooring shall be durable and suitable for its application.
- Lift car skirting shall be finished stainless steel;
- Lighting within the lift car shall consist of diffused LED down lights or strip lights and provide a minimum of 100 lux evenly distributed over the floor of the lift car;
- Where lifts are provided in glass lift shafts the lifts shall incorporate lift car air conditioning;
- A GPO must be installed;
- Where glass is used it shall comply with the requirements of Appendix H of AS1735.

Acceptable lift interior finishes based on lift type are:

11.3.7.1 Goods Lifts

For goods lifts the lift car interior shall consist of finished or rimex stainless steel walls with at least two rows of stainless steel bumprails;

Handrails shall be of finished stainless steel finish;

Ceilings shall be white colour laminate or finished stainless steel.

LED lighting shall be provided and shall be located within pelmets and provide a minimum 100lux on the floor of the lift;

Excelon vinyl floor tiles provided by Armstrong Commercial Flooring shall be used.

11.3.7.2 Passenger Lifts

For passenger lifts predominantly used by students the car interiors shall consist of finished stainless steel and/or mirror finishes for the side walls. The rear wall shall consist of colour backed glass. The glass may include an etched image of the University logo.

Ceilings shall be white colour laminate.

Lighting shall consist of diffused LED lighting and located so that it shall not wash out the information on the COP's. Lighting shall provide a minimum of 100Lux evenly distributed over the floor of the lift.

Handrails shall be of finished stainless steel finish;

Excelon vinyl floor tiles provided by Armstrong Commercial Flooring shall be used.

11.3.8 Lift Appointments

The following requirements are applicable to car and landing appointments:

11.3.8.1 Buttons

Buttons shall be of the Dewhurst US95 or US96 type and shall be dual illuminating white/blue or other approved colour combinations. Buttons shall include Braille and tactile information as per the requirements of AS1735.12.

11.3.8.2 Car Operating Panel (COP)

Car operating panels shall be designed in line with the requirements of AS1735.12 regarding location, type, height and location of buttons.

Lift number and building address details shall be engraved on the COP.

The project architect shall ensure that each level is correctly labelled according to the University's room numbering system. Refer to Section 1 of the Design Standards, Planning and Architecture.

11.3.8.3 Displays

Displays shall be of the colour LCD PI-70 type as provided by Pixel Technology Technologies or approved equivalent. Displays shall be capable of permanently displaying the University's logo whilst displaying lift direction and level indication. Displays shall also be capable of displaying messages relating to the lift status including: name of floor at which lift is arriving, "Exclusive Service", "Fire Service", "Out of Service", other fault/status messages as appropriate.

11.3.8.4 Hall Lanterns

One hall lantern shall be provided per lift entrance and shall indicate direction of travel of arriving lift by visible and audible means. Two sound signals for downward travel of arriving lift and one sound signal for upward travel.

The design of the hall lantern shall be such that it consists of jewels projecting approximately 20mm past the hall lantern faceplate. Jewels shall be illuminated via long-life LEDs.

Car position indication shall be provided within the hall indicator and shall indicate direction of travel as well as lift position.

11.3.8.5 Hall Button Station

Hall button stations shall be located so that the button heights comply with the requirements of AS1735.12. Hall button stations shall incorporate "Do not use" signage in accordance with NCC requirements. Signage shall be engraved on the landing button faceplate.

11.3.8.6 Car Fan

The lift car fan shall be operated via a push button in the car operating panel. A key switch operated fan is not acceptable. Upon activation of the fan the fan shall operate for a period of 2 to 5 minutes, adjustable.

The extractor fan shall be mounted on the car roof with sound isolated supports.

11.3.8.9 Voice Annunciation

Voice annunciation shall be provided in each lift car to the requirements of AS1735.12. The volume of the voice annunciation shall be adjustable and the voice projection shall be clear and free from accent.

In addition to the above lifts shall be provided with a building evacuation speaker.

11.3.8.10 Key Switches

Key switches shall be provided at Practical Completion for Fire Service, Exclusive Service and Light Switch. The Fire Service key arrangement must comply with the requirements of AS1735. The Exclusive Service key arrangement shall include ON, OFF and PARK facilities.

The keying system shall be:

Bilock 'B' – Fires Service;

TOK 3 – Exclusive Service and car light and fan;

TOK 9 – Special features such as Hazardous Goods Service.

11.3.8.11 Emergency Lights

Each lift shall contain an automatically rechargeable emergency lighting system that operates at least two emergency lights and is capable of providing at least 50 lx for 2 hrs, on each control panel.

This lighting shall come on automatically upon failure of the normal lighting supply.

11.3.8.12 Fixings

Fixings for all appointments shall be of the hidden type if possible. Alternatively, and visible fixings shall be of the security type and shall match the finish of the faceplate.

11.3.8.13 Entrance Protection

All lift entrances shall be provided with a Memco Panachrome, or approved equivalent, 3D entrance monitoring system consisting of infra-red beams continually monitoring the clear opening from 50mm above floor level to at least 1550 above floor level. The system shall be unaffected by dust, moisture, vibration and ambient light and shall comply with AS1735.12.

The system shall incorporate coloured indicators that operate on door movement. The detectors shall illuminate green when the doors are opening, flash red as they start to close, and stay red as the doors move together.

11.3.9 DDA Requirements

The lifts shall meet the full requirements of AS1735.12. The minimum facilities considered necessary to meet the access needs of people with disabilities as required by the NCC and AS1735.12 for the passenger lifts, include the following:

- Minimum 600mm long handrail located adjacent to the COP in compliance with the requirements of AS1735.12;
- Floor dimensions not less than 1,100mm x 1,400mm;
- Lift entrance protection system complying with AS1735.12;
- Minimum clear door opening on 900mm wide in accordance with AS1735.12;
- Lighting in accordance with AS1735.12;
- Emergency hands-free self-dialling push button initiated communication system with audible feedback;
- Alarm button shall illuminate when emergency communications has been established
- Car operating panels designed to meet AS1735.12 requirements;
- Levelling accuracy of ± 6 mm;
- Visible, tactile and audible information on landings and within the car;
- Call buttons per the requirements of AS1735.12

Disabled platform lifts compliant with AS1735.14 shall be an automatic type including automatic doors with a door height of no less than 1000mm. It shall not rely on constant pressure devices for its operation. The platform lift shall have a minimum platform size of 1100mm x 1400mm in compliance with DDA requirements.

The disabled platform lift shall be located in an area that is easily visible and accessible to the intended user. It shall not be located behind a door of any kind that may restrict the access to the lift.

Stair climber and non-automatic disable access lifts conforming to AS1735.15 will not be accepted.

11.3.10 Car and Landing Doors

Lift car and landing doors shall be of the two panel centre opening type where possible and practical. Door opening widths and heights shall be designed to suit the lifts application. Doors shall be finished stainless steel. Full depth door jams that project past the lobby finish shall be provided to all lifts. Goods lift door jambs shall be solidly grouted.

11.3.11 HLI Access Control Security

HLI Access control shall be provided to all lifts with the exception of platform lifts. The lift designer shall specify for the provision of HLI access control even if there is no project requirement to do so. This is for possible future connection.

The card reader shall be provided behind a cut-out with perspex cover and shall be located on the COP.

11.3.12 Emergency Communication System

The lift emergency communication system shall consist of a Pixel Technology Wireless Communication Gateway (EM-4GE2) incorporating a self-dialling hands-free telephone mounted in the car operating panel. The telephone shall be activated by means of pressing the phone button (to illuminate on pressing) on the car operating panel for 5 seconds and shall automatically dial a permanently attended location such as the University's Security Control Room. The phone system shall also be capable of receiving calls, and automatically deactivating upon time-out (adjustable), busy tone, etc.

It shall have capability for dual SIM to enable dual network redundancy. Emergency lift phones shall continue to operate during power interruptions due to confirmation that not all mobile phones will work from inside lifts -in particularly if below ground level e.g. Underground car parks. Battery backup power should be supplied.

System shall comply with AS1735.12.

The lift car and lift well communication system shall be self-diagnostic in compliance with EN81-28 and compatible with the current University standard emergency phone

11.3.13 Lift Well

Lift well shall be constructed in compliance with the NNC and EN81-20.

Lift pits shall be provided with pit sumps with a minimum size of 300x300x300 and shall include a sump cover. Lift pits shall slope towards the pit sump.

Concrete plinths or equal and approved equivalent for support of buffers, etc shall be specified.

11.3.14 Lift Well Access

Access to the lift pit shall be in accordance with EN81-20, through the lift entrance door if the pit is less than 2.5m deep, or alternatively through a pit access door complying with the requirements of the EN81-20 if the pit is 2.5m deep or greater.

11.3.15 Electromagnetic Compatibility

Where equipment including fittings, apparatus, appliances, wiring and the like is likely to be incompatible with emission levels, harmonics and power quality for other areas of the building, all such equipment shall be provided with suitable filtering to ensure correct operation in the environment.

11.3.16 Lift Monitoring

Lifts shall be provided with BAS signals that detail when the lift alarm has been pressed or when the lift is in a fault condition.

All lifts shall have provisions for future connection to a Lift Management System (LMS). For large buildings where the lift designer considers it is warranted, an LMS shall be provided. The system shall allow the operator to select units by group and individually, and give status of major normal operating characteristics, including access control status, as well as major defects and alarms. It shall also be capable of recording the incidence of demands on all units and responses in such a way as to allow ready analysis by individual units, groups, and selected time intervals.

11.3.17 Lift Machine Room Design Requirements

The design of the lift machine room shall comply with the following:

- Lift machine rooms, where provided, shall be designed in accordance with the requirements of AS1735.2 Section 5;
- Be suitably ventilated or air conditioned in accordance with the control and alarm requirements detailed in AS1735.2 Clause 5.15. Fresh air intake, if provided, shall be adequately filtered;
- Be suitably lit in accordance with AS1735.2 Clause 5.13. Lights shall be of an LED tubes or LED panel type fittings. Emergency lighting shall be of the non-maintained type;
- Entrances shall be 2-hr fire rated and shall be keyed with a B2.4 cylinder. Access keys shall only be available from the University campus security. Lift machine room entrances shall be provided with a 'Danger.....' notice in accordance with AS1735.2;
- Fire extinguishers and detection shall be provided in lift machine rooms;
- A permanent 415/240V 3-phase and neutral fire-rated power supply connected to a dedicated lift switchboard;
- Finishes to walls, floor and ceiling shall be durable and painted in full gloss enamel for easy cleaning. The ceiling colour shall be white and walls off-white. Floors shall be properly sealed and receive two coats of grey coloured paving paint;
- Any required lifting beams or lifting eyes shall be fitted with SWL notices;
- Lift shop drawings shall be laminated and hung on the LMR wall. Lift wiring diagrams shall be within protective sleeves and provided in bound booklets and shall be stored in the lift controller;
- At practical completion the lift machine room shall be clean and free of tools and redundant equipment.

11.3.18 Machine-Room-Less (MRL) Requirements

The design of the MRL lift shall comply with the following:

- MRL lifts shall only be considered for passenger lifts where speeds of 1.0 to 2.5m/s are required. When a lift speed of 2.5m/s and above is required conventional overhead lift motor room traction lifts shall be provided. Overhead lift motor room lifts shall also be considered where a high rated load is required, for example large goods lifts.
- The machine space shall have lighting with a minimum of 200Lux at the controllers.

- The control cabinet at the landing shall be fire rated and have a satin stainless steel finish.
- Where a control cabinet is remotely located from the lift, where the movement of the lift for maintenance or service cannot be observed through an open landing door or by other means, closed circuit television screen shall be provided in the controller for service staff viewing only with the camera(s) mounted in the lift well.
- Provide shaft cooling where glass walled shafts are exposed to sunlight or external air temperature.
- In the event the temperature in the machine space reaches or exceeds 40 degrees Celsius, automatic means shall be installed to prevent the lift from continuing to operate once it is at a floor level and the doors have opened.

11.3.19 Ride Quality and Acoustic Treatment

As a minimum the lifts shall meet the following ride quality requirements:

- Acceleration: 0.8 – 1.1 m/s²;
- Jerk: 1.8 m/s³;
- Lateral Vibration: ≤ 15 m-g (10 Hz filtered A95);
- Noise level inside car with lift running at contract speed, shall be less than 55 dB(A);
- Levelling accuracy of ± 6mm.

Lift guide shoes shall be of the roller guide type.

In order to reduce noise and vibration, lift equipment such as hoisting machines, controller, and if appropriate, switchgear, sheave, guide shoes, door mechanism and rope hitch shall be mounted on appropriate isolating pads or mountings.

11.3.20 Lift Contractor List

Prior to the issuing of tender documentation, the design consultant shall obtain a list of nominated lift contractors from the University's Project Manager.

11.3.21 Energy Considerations

The lift designer shall consider the reduction of lift energy usage when designing the lift system. The following shall be considered for all lift applications:

- Automated switching of light fittings and screens in lift cars and on landings, to reduce the electrical load to the minimum allowable when lifts are idle. Lights and screens shall automatically be switched off whenever the lift has been idle for 2 minutes, except when the lift is in a special operation mode (exclusive, fire, etc), or if the lift is in a failed start or fault condition;
- The lift drives shall be based on variable frequency AC permanent magnet motors;
- Drives for lifts in new buildings shall have a regenerative capability that recovers excess energy in an overhauling condition to be returned to the electrical mains rather than rejected as heat.

11.3.22 List of Required Drawings

During the design phase of the project the following drawings shall be submitted to the University Project Manager for review:

- Lift layouts;
- Lift car interiors;

- Lift landing entrances;
- Lift car and landing faceplate appointments;
- Lift notices, labels and signs; and
- Any other item of equipment visible to a normal user of the finally installed equipment.

11.3.23 As-Built Documentation, Manuals and Related Information

Four weeks prior to practical completion of the project the University shall receive draft copies of the following documentation. Final copies are to be provided no later than four weeks after practical completion.

- Project specification;
- As installed drawings;
- Operation and Maintenance Manuals;
- Certificate of Electrical Safety;
- Testing verification in accordance with requirements of EN81-20 and EN81-50
- Plant Registration documentation in the University's name;
- Plant Design Notification documentation (if applicable);
- Hazard and Risk Assessment as provided by the lift contractor;
- All hardware, software & documentation required for diagnostics and maintenance activities;
- Details of the following performance at the point of handover:
 - Ride Quality results
 - Door open and close times
 - Door dwell times
 - Floor levelling accuracy
 - Acceleration and deceleration rates
 - Jerk rate
 - Contract speed
 - Flight times (door open to door open) for one, two and four floor runs

11.3.24 Maintenance Records

The project documentation is to include a requirement that the lift contractor is responsible for all maintenance (including breakdown, preventative etc) and servicing requirements during the defect liability period. A comprehensive record of maintenance carried out during the defects liability period shall be kept on site for all preventative maintenance, breakdown calls and repairs carried out. Copies of these records shall also be forwarded to the Engineering Services Manager.

At the end of the initial six-month maintenance period the maintenance contractor shall produce a performance report giving details of operation versus design parameters.

All maintenance records shall be submitted to the University on expiration of the defects liability period.

11.4 BUILDING MAINTENANCE UNIT DESIGN

The selection and design of Building Maintenance Unit (BMU) services installed at 'The University of Melbourne', shall take into account the requirements of the Design Standards. The designer shall produce their own specification incorporating the following information and submit all designs to the University Project Manager for review prior to tender or any works commencing on site.

This design standard details the minimum requirements applicable to certain components of the BMU installation and details the design intent. The designer must use the Modification Request Form to seek approval for any departure from any clause in the design standards.

11.4.1 Applicable Standards

The design of BMU systems shall comply with the current regulations and requirements of the Authorities having jurisdiction over the project.

The BMU shall meet the requirements of relevant Australian Standards and Work Health and Safety regulations. The BMU designer, installer and maintenance provider shall identify, eliminate and/or control all hazards to health and safety associated with the installation, commissioning, decommissioning, dismantling, erection and use of the BMU.

The BMU system shall be designed and installed in accordance with the following codes and regulations and shall conform to a Safety in Design principle:

- AS1418.1 Cranes, Hoists and Winches – General Requirements
- AS1418.13 Cranes (including Hoists and Winches) – Building Maintenance Units
- AS 2550.13 Cranes, Hoists and Winches – Safe Use - Building Maintenance Units
- Occupational Health and Safety Act and Regulations.
- National Construction Code of Australia (NCC);
- AS3000 Wiring Rules;
- Equipment (Public Safety) Regulations
- Authorities having jurisdiction over the works.

The contractor is to ensure that the BMU design is registered with Work Safe Victoria in the name of "The University of Melbourne" as the owner.

11.4.2 Design Objectives

The BMU Services shall be based on appropriate commercial design standards, and good engineering practices, incorporating:

- Space in which plant is to be installed shall ensure that the intended equipment can be properly accommodated without alteration to the base building design.
- Minimum design life is to be 25 years or longer as required in order to meet the design life of the building structure and the façade to be serviced,
- Facility for garaging the BMU is recommended for longevity,
- All metal within the structure of a building maintenance unit shall be treated to prevent corrosion,
- Appropriately designed stable working platform that ensures safe access and egress, includes safety harness anchor points and means for a restraint system,

- Safe means of access and facilities to enable inspection and maintenance of the BMU,
- Weatherproof control cabinet and operating panel,
- Emergency rescue provisions shall be designed in to the system which may include the ability to land the platform at the bottom of the building in all platform drop positions,
- A permanently connected communication system shall be provided as per the requirements of Section 8 of AS1418.13,
- The BMU shall be provided with detailed operator instructions and shall include appropriate security systems and procedures that ensure only trained operators are able to use the BMU.

11.4.3 BMU Installation and Operation

All BMU installation and operational activities shall be carried out by competent persons who have the training and experience necessary to carry out the works.

11.4.4 As Installed Equipment Label

The BMU shall be provided with a permanent and legible installation information plate with the following details (in English):

- Australian Standard to which the equipment is installed
- Date installed/upgraded
- Statutory registration details
- Manufacturer's name, installer's information.
- Country of manufacture.
- Serial number or other identifying number.
- Safe working load on the components (of a davit system).
- Safe working load of the platform.
- Details of the wire ropes used, as follows:
 - (i) Nominal size.
 - (ii) Grade.
 - (iii) Construction.
 - (iv) Minimum breaking strength.
 - (v) Rope lengths.
- Basic operating instructions on the drive unit and working platform.
- An instruction notice stating that the building maintenance unit shall be parked in a nominated parking position (where applicable).
- Contact telephone number for the University's Security Control Room.

11.4.5 List of Required Design Information

During the design phase of the project the following information shall be submitted to the University Project Manager for review:

- Roof layouts showing position of each platform drop,
- Track or runway details including anchor points,

- Platform restraint details;
- Drive unit details including operating and travelling speed
- Loads on building structure,
- Lift notices, labels and signs; and
- Any other item of equipment visible to a normal user of the finally installed equipment.

11.4.6 As-Built Documentation, Manuals and Related Documentation

Four weeks prior to Practical Completion of the project the University shall be provided with copies of the following documentation:

- Project specification;
- As installed drawings;
- Operation and Maintenance Manuals;
- Certificate of Electrical Safety;
- Testing verification in accordance with requirements of AS 1418.13
- Plant Registration documentation in the University's name;
- Plant Design Notification documentation (if applicable);
- Hazard and Risk Assessment as provided by the BMU contractor;
- All hardware, software & documentation required for diagnostics and maintenance activities;

11.4.7 Maintenance

The project documentation is to include a requirement that all maintenance (including preventative and breakdown) and servicing during the defects liability period is to be undertaken by the installation contractor. The BMU shall be maintained in a safe working condition and a preventive maintenance programme shall include periodic and routine maintenance carried out quarterly in accordance with the requirements of AS 2550.13.

11.4.8 Maintenance Records

A comprehensive record of maintenance carried out during the defects liability period shall be kept on site for all preventative maintenance, breakdown calls and repairs carried out. Copies of these records shall also be forwarded to the Manager Engineering and Infrastructure.

At the end of the first six-months of the defects liability period the maintenance contractor shall produce a performance report giving details of operation versus design parameters.

All maintenance records shall be submitted to the University's Manager Engineering and Infrastructure on expiration of the defects liability period.

11.5 DESIGN CHANGE AUTHORISATION

All requests for changes to the requirements of the Design Standards must be made on the Modification Request Form. No design work is to proceed on the basis of the proposed modification until the modification request has been approved in writing.

**SECTION 12: ACOUSTICS, VIBRATION AND EMI
CONTENTS**

12.1	INTRODUCTION	2
12.2	INTERNAL NOISE LEVELS	3
12.3	EXTERNAL NOISE LEVELS	4
12.4	SOUND INSULATION	4
12.5	INTERNAL ACOUSTICS	6
12.6	VIBRATION	7
12.7	COMMISSIONING TESTING	7

12.1 INTRODUCTION

This section of the Design Standards provides details of the minimum requirements for the acoustic design of new and refurbished University spaces.

The project designer is required to produce their own specification which satisfies the requirements of this and other sections of the Design Standards. All designs are to be submitted to the University for review prior to tendering or any works commencing on-site. The Design Standards are to be considered in conjunction with all relevant statutory regulations.

The designer must use the Modification Request Form to obtain approval from the University for any departure from any clause in the Design Standards. No design work is to proceed on the basis of the proposed modification until the modification request has been approved in writing. Any proposed departures would generally be required to be accompanied by justification from a suitably qualified Acoustic Consultant.

An appropriately qualified Acoustic Consultant shall be engaged as part of the project team; especially in areas where high acoustic performance is required due to:

- high noise levels (roads/rail, plant rooms, etc.),
- noise sensitive spaces (performance spaces, libraries, accommodation, etc.)
- vibration sensitive spaces (laboratories)
- speech privacy requirements (private offices, counselling rooms, etc.)

Acoustic Consultants must be a member firm of the Association of Australasian Acoustical Consultants (AAAC).

Examples of rooms/spaces where high acoustic performance is required include:

- auditoriums,
- lecture theatres,
- board and conference rooms
- private offices
- libraries,
- study areas,
- theatres,
- drama, dance & music rooms,
- student accommodation.

Requirements for laboratories housing sensitive equipment (e.g. electron microscopes) and bio-resources are provided separately.

12.1.1 Standards, Policies, Regulations & Guidance

All work shall meet the requirements of the national and local authorities, and shall be in accordance with the following as relevant to the project:

- Australian/New Zealand Standard AS/NZS 2107 *Acoustics – Recommended Design Sound Levels and Reverberation Times for Building Interiors*.
- Australian Standard AS2021 *Acoustics - Aircraft noise intrusion - Building siting and construction*
- State Environmental Protection Policy (Control of Noise from Commerce, Industry and Trade) No. N-1 ([SEPP N-1](#))
- State Environmental Protection Policy (Control of Music Noise from Public Premises) No. N-2 ([SEPP N-2](#))
- [Noise from Industry in Regional Victoria](#) (NIRV)
- National Construction Code (NCC) / Building Code of Australia (BCA)

- [Assessing Vibration: A Technical Guideline](#), NSW Department of Environment and Conservation, February 2006.
- AAAC Guideline for [Educational](#) Facilities, Version 2.0

Other guidance documents which may assist the designer in relation to the acoustics include:

- Section 6.11 of the [Building Quality Standards Handbook](#) published by the Department of Education and Early Childhood Development
- Chapters 4 and 5 of [Sound Transmission and Insulation in Buildings](#) published by the Australian Building Codes Board.

Acoustic criteria and recommendations within these guidance documents do not supersede the information provided within these Design Standards. Guidance Documents should be used for information only.

12.2 INTERNAL NOISE LEVELS

The total internal noise level within a space from steady and quasi-steady noise sources should exceed the levels stated in AS/NZS 2107 “*Acoustics — Recommended design sound levels and reverberation times for building interiors*”. This should include:

- noise generated by building services serving the space itself
- noise intrusion from mechanical plant serving other buildings and spaces
- noise intrusion from external sources such as road traffic, tram and rail noise.

Transient noise sources, such as rain and aircraft noise, should also be considered in the design but are not subject to the AS/NZS 2107 design criteria.

12.2.1 Building Services Noise

Noise from building services (including mechanical services and hydraulics services) shall be free of tonal and spectral content and not exceed the levels stated in AS/NZS 2107 “*Acoustics — Recommended design sound levels and reverberation times for building interiors*”. Where a design sound range is provided, the lower level is to be used as a design goal and the upper level indicates the maximum permissible level on-site. Additional guidance for internal noise levels for education spaces can be found in the AAAC *Guidance for Educational Facilities*.

AS/NZS 2107:2016 notes that when the sound level is below the lower level of the range, the inadequacy of background sound to provide masking sound can become problematic, by allowing other intermittent noise sources to cause distraction, annoyance, or lack of privacy. In spaces where acoustic isolation and speech privacy are important, and the sound levels are below the lower level of the recommended design range, acoustic masking may be required to be introduced into the space to raise the sound level to within the recommended design sound range level.

For noise sensitive spaces such as auditoriums, lecture theatres and other enclosed rooms, Appendix C of AS/NZS 2107:2016 provides maximum recommended octave band sound pressure levels which can be scaled appropriately to achieve the a suitable overall L_{eq} recommended design level for the space.

12.2.2 Rain Noise

In line with the advice provided with the AAAC [Guideline for Educational Facilities](#), the internal noise level with a rainfall rate of 25 mm/hr should not exceed the upper extent of the AS/NSZ 2107 noise level range by more than 5 dB(A).

12.2.3 External Noise Intrusion

External noise intrusion into University facilities shall be limited so that the total internal noise level (including building services) within spaces does not exceed the levels stated in AS/NZS 2107 “Acoustics — Recommended design sound levels and reverberation times for building interiors”. Where a design sound of range is provided, the lower level is to be used as a design goal and the upper level indicates the maximum permissible level on-site.

Where University facilities (especially student accommodation) are close to highways, freeways, busy arterial roads and rail corridors, the Acoustic Consultant shall design the building envelope or provide noise mitigation advice to suitably reduce the internal noise levels.

Where University facilities are under flight paths for aircraft or helicopters, external noise intrusion from these sources should also be considered. In these cases, facilities should be designed to achieve compliance with AS 2021 *Acoustics - Aircraft noise intrusion - Building siting and construction*.

12.3 EXTERNAL NOISE LEVELS

12.3.1 Mechanical Services

Within metropolitan Melbourne, the *State Environmental Protection Policy (Control of Noise from Commerce, Industry and Trade) No. N-1* ([SEPP N-1](#)) regulates environmental noise emissions to neighbouring noise sensitive areas (residential, hotels, hospitals, etc.). To comply with this legislation, noise at adjacent noise sensitive areas due to the operation of mechanical plant must not exceed noise limits determined in accordance with the legislation.

Outside metropolitan Melbourne, the *Noise from Industry in Regional Victoria* provides guidance on environmental noise emissions to neighbouring noise sensitive areas.

Additionally, operation of mechanical plant shall not cause internal noise levels in adjacent land uses not covered by SEPP N-1 to exceed those contained in AS/NZS 2107 “Acoustics – Recommended Design Sound Levels and Reverberation Times for Building Interiors”.

12.3.2 Music Noise

The State Environmental Protection Policy (Control of Music Noise from Public Premises) No. N-2 ([SEPP N-2](#)) regulates music noise emissions to neighbouring noise sensitive areas (residential, hotels, hospitals, etc.). To comply with this legislation, music noise at adjacent noise sensitive areas must not exceed noise limits determined in accordance with the legislation.

In many instances music noise from University facilities would not strictly need to comply with this policy as they would not be defined as an ‘Indoor Venue’ or ‘Outdoor Venue’ under SEPP N-2. However, music performances or events should comply with the requirements of this policy as part of a best practice approach.

12.4 SOUND INSULATION

In order to achieve the appropriate level of sound insulation between spaces, partitions must be designed to achieve a minimum measured acoustic performance on site.

Weighted Sound Reduction (R_w) values are used for design and procurement purposes of individual building elements. Weighted Level Difference (D_w , $D_{n,w}$ and $D_{nT,w}$) values are used for in-situ verification of construction performance, because they provide a

measure of the 'as-experienced' condition including the level of degradation from any unwanted flanking paths which can arise from poor design and/or construction.

The advice below is based on D_w values. For the purposes of design, it is sufficient for the assessment to be carried out on the basis of R_w values for different elements. The R_w value of a large element (e.g. wall or floor) should be selected such that it is at least 5 dB above the desired D_w value, and specific consideration should be given to the design of smaller elements and detailing such that the desired D_w value between the two spaces is achieved.

Further information can be found in the Appendix of AAAC [Guideline for Educational Facilities](#).

12.4.1 Airborne Sound Insulation

For walls without doors, the AAAC [Guideline for Educational Facilities](#) provides recommended D_w sound insulation ratings for various room types based on the noise generated within room types and the noise tolerance of the room adjacent (Table 3 and Table 5 of AAAC *Guidance for Educational Facilities*). Sound insulation of walls for University facilities shall be designed so that the D_w ratings are met upon completion of the project.

The sound insulation requirements within the AAAC [Guideline for Educational Facilities](#) are based on a typical ambient noise levels of L_{eq} 35 – 40 dB(A). For lower internal noise levels, the sound insulation rating needs to be increased to achieve a similar subjective performance. For every 5 dB(A) reduction in the background noise level, the D_w requirement shall be increased by 5 dB to achieve the same subjective performance.

12.4.2 Doors

Where doors are proposed between spaces, consideration must be given to the placement and performance requirements of the door since ratings for doors with no acoustic treatment are not likely to exceed D_w 20 dB while standard solid core doors with full perimeter acoustic seals could achieve a rating of up to D_w 30 dB.

Proprietary acoustic door systems can achieve a sound insulation greater than D_w 30 dB if manufacturer installation instructions are followed. However, these doors are heavier than standard doors and can be more difficult to operate. This should be considered (especially in relation to DDA door force limits) where proprietary acoustic doors are proposed.

The D_w for walls containing doors should only be reduced by a maximum of 10 dB compared to the D_w of the wall only (i.e. does not contain a door). If a wall containing a door is required to achieve a D_w greater than 35, then a proprietary acoustic door, back-to-back doors, or airlock design will likely be required.

It is acoustically preferable to use hinged doors rather than sliding doors as it is more practical to achieve an airtight seal around the door. Hinged doors shall be used for all spaces requiring high acoustic performance. Sliding doors shall only be used in D_w 40 walls or lower where speech privacy is not important.

For adjacent spaces, all doors should not be located adjacent to each other. Wherever possible, doors to adjacent spaces should be separated by 2 metres or more.

12.4.3 Operable Walls

Acoustically rated operable walls may pose operational and manual handling constraints, as a heavy mass is required to achieve a high level of sound attenuation. Lighter more easily operated walls may be used where walls are opened and closed frequently, but only where a lower level of acoustic separation has been accepted.

Operable walls shall:

- be rated to a minimum R_w 50
- have mechanically adjustable ends, and it is also preferable for the doors to have mechanically adjustable top and bottom seals, however, contact seals are acceptable if manufacturer warrants their performance
- have a baffle above the operable wall constructed from 1 x 13 mm plasterboard on one side of the structural member
- have adjacent ceilings with a Ceiling Attenuation Class (CAC) of 35 or higher. Adjacent ceilings with a CAC lower than 35 will require an upgrade to the operable wall or the ceiling baffle or both. Advice shall be sought from an appropriately-qualified Acoustic Consultant.

12.4.4 Impact Isolation

For floor impact noise, the of AAAC [Guideline for Educational Facilities](#) provides recommended L_{nTW} impact isolation ratings for various room types based on the noise generated within room types and the tolerance of the room adjacent (Table 3 and Table 4 of AAAC *Guidance for Educational Facilities*). Impact isolation ratings of floors for University facilities shall be designed so that the L_{nTW} ratings are met upon completion of the project.

12.4.5 Student Accommodation

For University student accommodation the acoustic requirements within Part F5 of the National Construction Code (NCC) / Building Code of Australia (BCA) shall be achieved as a minimum standard. In particular, impact noise isolation of floors shall be designed to achieve a higher standard than the nominated rating in the NCC / BCA. The impact noise isolation of new developments shall aim to achieve $L_{nTW} \leq 50$, and the impact noise isolation of refurbished accommodation shall aim to achieve $L_{nTW} \leq 55$.

12.5 INTERNAL ACOUSTICS

12.5.1 Reverberation Time

Reverberation Time (T_{60}) is measured in seconds and indicates how quickly sound decays within a space. The higher the T_{60} , the more reverberant or acoustically “live” is the space. A low T_{60} indicates an acoustically “dead” space. A higher T_{60} generally promotes higher noise levels during activity which results in worsening conditions for communication.

The reverberation times within University spaces are to be designed to comply with the recommended reverberation times within AS/NZS 2107 “*Acoustics — Recommended design sound levels and reverberation times for building interiors*”. Additional reverberation time guidance for education spaces can be found in the AAAC [Guideline for Educational Facilities](#).

For performance spaces and rooms where music/speech quality is important (i.e. auditoriums, lecture theatres, drama & music rooms, etc.) the location and extent of acoustic absorption within the room should be designed by the Acoustic Consultant to achieve the required reverberation time. Note that, for specialist performance spaces, limited guidance on suitable reverberation times is provided in AS/NZS 2107 and additional guidance on an appropriate design standard should be sought from an appropriately-qualified Acoustic Consultant.

12.5.2 **Speech Transmission Index**

Speech Transmission Index (STI) describes the clarity of speech in a space, and takes account of the space's acoustic characteristics, the background noise level and other noisy activities which may be occurring.

AAAC *Guidance for Educational Facilities* provides STI values for spaces where high quality speech communication is important such as:

- Open plan teaching areas
- Auditoria
- Gymnasias (sole use)
- Multipurpose Hall.

The internal acoustics of these types of spaces shall be designed so that the STI values in Table 6 of the AAAC [Guideline for Educational Facilities](#) are met upon completion of the project.

12.6 VIBRATION

12.6.1 **Mechanical Plant**

Radiated structure borne noise caused by vibration from building service plant shall be limited to ensure the internal noise limits (refer to Section 12.2) are not exceeded.

12.6.2 **Building Isolation**

The building structure should be designed so that vibration levels comply with the levels for "Education Institutions" published within [Assessing Vibration: A Technical Guideline](#), NSW Department of Environment and Conservation, February 2006.

12.7 COMMISSIONING TESTING

For projects containing spaces where a high acoustic performance is required, the University may require acoustic commissioning testing.

In such cases, a commissioning testing methodology is required to be submitted to the University for approval to ensure that the selection of spaces is appropriate. Generally, it would not be necessary or practical for testing to be carried out on every space, but a sufficient number of spaces should be tested to enable verification of the design. As a minimum, 10% of high acoustic performance spaces should be tested.

The tests should have regards to the acoustic sensitivities of the spaces and the works that were carried out. For example, it may not be necessary to carry out commissioning testing of airborne noise separation for projects where no works were undertaken to walls. Similarly, vibration testing would not generally be required where there has been no change to the structure of a building.

The methodology for the tests should address the requirements of this section of the Design Standards and the requirements outlined below.

12.7.1 **Walls and Floors**

The airborne rating of building elements is to be carried out and assessed in accordance with

- AS/NZS ISO 717.1:2004 Acoustics—Rating of sound insulation in buildings and of building elements Part 1: Airborne sound insulation, and
- AS ISO 140.4—2006 Acoustics – Measurement of sound insulation in buildings and of building elements – Part 4: Field measurements of airborne sound insulation between rooms for airborne sound separation between rooms.

The impact noise rating of floors is to be carried out and assessed in accordance with:

- AS/NZS ISO 717.2 Acoustics—Rating of sound insulation in buildings and of building elements Part 2: Impact sound insulation.
- AS ISO 140.6—2006 Acoustics—Measurement of sound insulation in buildings and of building elements Part 6: Laboratory measurements of impact sound insulation of floors for impact noise separation between floors.

12.7.2 Noise Levels

Noise levels shall be measured in accordance with Section 6 of AS2107:2016. Appendix D of AS/NZS 2107 provides information on identifying spectral imbalance and tonal components of internal noise levels.

12.7.3 Reverberation

Reverberation times shall be measured in accordance with Section 6.2 of AS/NZS 2107:2016.

12.7.4 Vibration

Vibration levels shall be measured to allow comparison with the levels for “Education Institutions” published within [Assessing Vibration: A Technical Guideline](#), NSW Department of Environment and Conservation, February 2006.

SECTION 13: SECURITY CONTENTS

13.1	INTRODUCTION	3
13.2	PRINCIPLES OF SECURITY CLASSIFICATION	3
	13.2.1 Classification Criteria	3
	13.2.2 Application to Building Design	4
13.3	UNIVERSITY APPROVED CONTRACTORS	5
13.4	OPERATIONAL REQUIREMENTS	6
13.5	ELECTRONIC SECURITY SYSTEMS	7
	13.5.1 Building Access Control Design Criteria	7
	13.5.2 Door Requirements	9
	13.5.3 Electronic Intrusion Alarm System	13
	13.5.4 CCTV System	14
13.6	MECHANICAL SECURITY SYSTEMS	16
13.7	EMERGENCY HELP POINTS (BLUE PHONES)	17
13.8	LIGHTING	17
13.9	RADIO EQUIPMENT	17
13.10	INTERFACE WITH THE FIRE PANEL	17
13.11	SECURITY EQUIPMENT (HARDWARE)	18
	13.11.1 Electric Door Strike	18
	13.11.2 Electric Mortice Lock	18
	13.11.3 Magnetic (Static) Locks	18
	13.11.4 Controller Panels	18
	13.11.5 Controller Cabinets	18
	13.11.6 Expansion Interface Modules	19
	13.11.7 Access Cards, Card Readers and Exit Devices	19
	13.11.8 Break Glass Units	19
	13.11.9 Duress Buttons	20
	13.11.10 Door Monitoring	20
	13.11.11 DC Emergency Power Supplies	21
	13.11.12 240 Volt Power Supplies	21
	13.11.13 Passive Infra-Red Detectors	21
	13.11.14 Glass Break Detector	21
	13.11.15 Intercom System	21
	13.11.16 Grey Boxes	21
	13.11.17 Key Switches	22

13.11.18	Condition of Equipment	22
13.12	INSTALLATION REQUIREMENTS	22
13.13	SYSTEM PROGRAMMING	22
13.14	GRAPHIC MAPS	23
13.15	NAMING CONVENTION	23
13.16	CABLING	25
13.17	NETWORK INFRASTRUCTURE	26
13.18	SYSTEM TRAINING, AS-BUILT DOCUMENTATION AND OPERATION & MAINTENANCE MANUALS	27
13.19	TESTING & COMMISSIONING	27
13.20	NOTICE OF COMPLETION	28
13.21	DESIGN CHANGE AUTHORISATION	28
13.22	APPENDICES	29
13.22.1	Appendix A – Automatic Door Wiring Diagram	29
13.23	APPENDIX B – CONTRACTOR PROGRAMMING REQUIREMENTS	30
13.23.1	Workshare Arrangement for Commissioning of Gallagher Access Control System for the University of Melbourne	30
13.23.2	Prerequisites	30
13.23.3	Installation Contractor Responsibilities	30
13.23.4	Commissioning Contractor Responsibilities	31
13.23.5	Integrations and other non-standard functions	31

13.1 INTRODUCTION

The section provides the minimum standards for the electronic security design for new developments and/or upgrades to existing buildings.

The building security concept shall be established during the design stage of each project and shall be based on a risk based approach. The design consultant shall meet with the University Security Manager and relevant stakeholders to identify the security risks which are required to be mitigated. These security measures shall become the basis of the security concept design. The design consultant shall then develop the detailed design based on the security concept design.

The design consultant is required to produce their own project specification which incorporates this section and other sections of the Design Standards, notably, the Electrical Services, Fire Protection and Detection Services, Building Trades and Standards for the installation of Telecommunication Networks; together with the requirements of all relevant codes, standards and good practice guides.

This section of the Design Standards only takes into consideration the physical security measures employed to deter, detect, and delay unlawful activity. Information Technology security measures are outside the scope of this document.

13.2 PRINCIPLES OF SECURITY CLASSIFICATION

The security classification of buildings, or areas within buildings, is based on the degree of damage which could be caused to the University through personal injury; loss of, or damage to property (including intellectual data) or interruption to a critical service.

13.2.1 *Classification Criteria*

The following is a general list of functions of particular concern requiring security consideration:

- Store rooms containing radioactive material or dangerous chemicals;
- Computer laboratories, with 24-hour access;
- Biological resource facilities;
- Lecture theatres;
- Areas of substantial intellectual or monetary value (e.g. computer software design, saleable medical research etc.);
- Places handling substantial quantities of money;
- Areas in which critical administrative functions are carried out (e.g. office of The Vice Chancellor, University Information Division Computer Room, Information Division Plant, Network Distribution Switch rooms, Student Records Office and PABX rooms);
- Sensitive waste storage;
- Mission critical plant rooms or infrastructure such that the loss of functions would significantly disrupt the day-to-day operations of the University or areas of the University;
- Rooms where examination papers are stored;
- Rooms or buildings housing vulnerable or “at risk” individuals.
- Extended hours areas, such as study zones and libraries;
- Accommodation facilities;

- Crowded places, such as sports stadia, concert event spaces, etc. These spaces may be outdoors as well as indoors.

This list is not meant to be exhaustive. There may be rooms or areas other than on the list above requiring security consideration. These rooms or areas should be clearly identified by the design consultant based on the risk based approach described.

13.2.2 **Application to Building Design**

The protection afforded to the assets is linked to the hierarchy of space that exists within all environments. The general hierarchy is as follows:

Category of Space	General Condition of use/access	Comments
Public	Areas that are freely accessible to members of the public.	External spaces, buildings with free access.
Semi-public	Areas that are accessible to members of the public by invitation but where there is no specific criteria in place.	Social environments, sporting facilities and free events.
Semi-private	Areas that are restricted to those with a legitimate reason for being there plus invitees that meet agreed criteria.	Areas where visitors are required to pay a fee or are subject to some form of screening.
Private	Areas that are restricted to those with a legitimate reason for being there. Visitors are escorted at all times.	Working areas of the University restricted to staff members and students etc. Visitors carrying out specific tasks.
Secure	Areas where access is limited to nominated individuals only. Visitors are not normally allowed but where necessary are escorted at all times.	Areas containing critical equipment, facilities or items of intrinsic value. Visitors are normally excluded except for essential maintenance staff.

In accordance with the principles of Crime Prevention through Environmental Design (CPTED), the territorial definition of these spaces shall be clear and unambiguous; in addition, the transit between the spaces shall be reflected in the form and function of the access control measures to be adopted.

The greater the difference in status between adjacent spaces, the more robust shall be the physical measures, the more stringent the access controls between them and the level of surveillance practiced. Therefore, access to a secure area should be via a controlled door (appropriate to the location and usage), be alarmed and monitored by CCTV; whereas, access to a semi-private area may not require a controlled door, an alarm or to be monitored unless these are identified as appropriate controls during the risk assessment process.

Design principles relevant to security include:

- Access control design shall take into consideration the needs of disabled users, refer relevant DDA requirements;
- Passenger lift control functions;
- Design of the shell of the building;

- Design of internal user areas;
- Security of accessible low-level windows etc;
- Combining all high-security functions to one area of a building;
- External lighting design;
- Crime Prevention Through Environmental Design (CPTED);
- Specific operational requirements of the building or areas.

Refurbishments and new building designs shall have, as a minimum but not limited to:

- An access controlled main entry point in line with the Design Standards;
- Electronic locking and monitoring of all external doors;
- Access control on student A/H facilities;
- Access control on lift lobbies and communications rooms;
- Access control on biological resource facilities and lecture theatres;
- An interface between the fire panel and the Gallagher panel to indicate an alarm and to drop power to emergency egress doors;
- Intrusion detection devices to monitor private or secure areas; Remote arming terminals shall be installed at strategic locations for arming/disarming and to provide alarm status and system status monitoring;
- Where required by the University, intrusion detection devices to monitor internal common/public circulation areas;
- Where required by the University, intrusion detection devices to monitor internal doors;
- An Emergency Services Key Vault (Grey Box) keyed to the University's CyberLock electronic key system, supplied by the University Security Office.
- CCTV coverage to a standard commensurate with the location and purpose of the image. Areas to be covered include:
 - All entry points
 - External coverage of external doors
 - Entry/exit points of private or restricted areas
 - Student A/H facilities and computer rooms
 - Entry points to a floor
 - General circulation spaces
 - Alarmed locations, where required by the University
 - External public gathering spaces and thoroughfares surrounding University properties

13.3 UNIVERSITY APPROVED CONTRACTORS

All security system hardware must be installed by a University of Melbourne approved security contractor.

All restricted master keyed locks, cylinders and keys must be supplied through the University of Melbourne's nominated locksmith.

A current list of approved security contractors and the current nominated locksmith are available from the University Security Office or University Project Manager.

13.4 OPERATIONAL REQUIREMENTS

Security works must meet all the requirements of national and local statutory authorities and shall be in accordance with the following:

Standard Reference	Description
AS/NZS 3080:2013	Telecommunications Installations – Generic cabling for commercial premises
AS/CA S008:2010	Requirements for customer cabling products
AS/ACIF S009:2013	Installation requirements for customer cabling (Wiring rules)
AS/NZS 3084:2017	Telecommunications installations – Telecommunications pathways and spaces for commercial buildings
AS/NZS 3085.1-2004	Telecommunications installations – Administration of communications cabling system – Basic Requirements
AS/NZS 3000:2018	Electrical installations (known as the Australia/New Zealand Wiring Rules)
AS 2201.1-2007	Intruder alarm systems – Client’s premises – Design, installation, commissioning and maintenance
AS 2201.2-2004	Intruder alarm systems – Monitoring centres
AS 2201.3-1991	Intruder alarm systems – Detection devices for internal use
AS 2201.4-1990	Intruder alarm systems – Wire-free systems installed in Superintendent’s premises
AS 2201.4-1990/Amdt 1-1990	Intruder alarm systems – Wire-free systems installed in Superintendent’s premises
AS 2201.5-2008	Intruder alarm systems – Alarm transmission systems
AS/NZS 2201 Set-2008	Intruder alarm systems set
AS 4360	Risk Management
HB 167:2006	Security risk management
ASTM F571-87 (2016)	Standard Practice for Installation of Exit Devices in Security Areas
AS/NZS 60950.1:2015	Information Technology Equipment – Safety – General Requirements
AS 4806.1-2006	Closed Circuit Television (CCTV) Management and Operation
AS 4806.2-2006	Closed Circuit Television (CCTV) Application Guidelines
AS 4806.3-2006	Closed Circuit Television (CCTV) PAL signal timings and levels
AS 4806.4-2008	Closed Circuit Television (CCTV) Part 4: Remote Video
AS 5007 – 2007	Powered doors for pedestrian access & egress
AS 1428	Design for Access and Mobility

- Building Code of Australia and building permit conditions;
- Electricity supply authorities;
- Fire brigade requirements;
- The rules and regulations of local government;
- All other relevant codes and standards.

13.5 ELECTRONIC SECURITY SYSTEMS

The *Gallagher Command Centre Site Management System* shall be specified for intrusion detection and access control applications in University buildings and/or areas.

IndigoVision CCTV cameras and Network Video Recorders shall be specified for surveillance and monitoring purposes.

2N IP Intercom units shall be specified for intercom units and Blue Phone communication purposes.

13.5.1 Building Access Control Design Criteria

Online Access Control System

The microprocessor based control unit shall be a fully redundant system (that shall remain in operation if the *Security TCP/IP network* is offline) with a distributed processing network topology.

Whilst operating, the system shall grant or deny access through a door to a card holder based on the presentation of a properly encoded card to an authorised card reader at a valid time of day, day of week and card status. Each individual card transaction, both through entry or egress card readers, shall log as a separate event at each door, i.e. entry shall be distinguishable from egress at the same door.

The system shall be connected to a dedicated security Virtual Local Area Network (VLAN). Battery backup shall be provided to maintain normal access control operations including all memory and the real time clock calendar for not less than 8 hours should mains power fail. The battery shall be automatically recharged when mains power is applied.

When the dedicated security LAN becomes offline, all events and transactions shall be retained in its memory. These events and transactions shall automatically upload to the database of the Gallagher Command Centre management software when the security LAN connection re-establishes.

All events and transactions shall be stored in the central database with time & date stamps. The time & date stamps shall be referenced for security data retrieval.

Gallagher Command Centre site management software is in use at the University of Melbourne. All building security systems shall be connected to the Security network and shall be programmed as per sections 13.13, 13.14 and 13.15 of these Design Standards.

Note that not all Gallagher Command Centre management software functionalities are required. The Security Contractor shall refer to the capabilities of the Gallagher Command Centre management software and liaise with the Security Office to identify specific features or functionalities for implementation.

Specific requirements shall include (but not limited to) the following:

- In principle, the design should encourage persons (staff, students, visitors and contractors) to enter or leave a building through the same access control points.

- The design should limit the number of public access control points. As far as practical, public access should be limited to one door;
- Doors shall be named according to conventions outlined in section 13.15 of these design standards;
- Floors shall be named according to convention outlined in section 13.15 of these design standards;
- Security controllers shall be named according to location;
- Label all security panels, security equipment and cables according to a labelling scheme agreed with the University Security Office during installation;
- Provide regulated power supply and battery system to back up the operations of the access controller and electronic door locking devices for 8 hours when there is a mains failure. Refer to section 13.11.11 for details;
- Label all batteries with the installation dates;
- Mechanical key override must be provided for all external access control doors and any internal access control doors that have no secondary path of access to the internal side of the door
- All mechanical cylinders must be keyed to the University of Melbourne's restricted keying system as nominated by the University Security Manager.
- All handles on electric strike doors shall be locked to avoid doors being opened mechanically by the handle and triggering a 'forced door' alarm;
- Install door closers on all monitored doors.

The design consultant shall discuss with the University Security Manager and other stakeholders to identify other specific requirements for implementation.

Electronic Key System

Electronic key system shall be CyberLock.

A user shall be able to turn the cylinder and open a door if the user carries a valid electronic key (with pre-programmed data).

The transaction or event shall be kept within the memory of the electronic key. The data shall be uploaded to the system database when the user presents the key to an online reader. At the same time when a user presents his/her key to an online reader, the programmed data stored in the electronic key memory will be updated (e.g. to update the list of accessible doors, to bad-list a key, to delete a door from the accessible door list, etc.).

Electronic key cylinders shall be utilised as an alternative to an online access control installation for 'back of house' services areas, where installation of an online access control solution is difficult or not viable e.g. Roof access hatches that can't be locked via a wired electronic locking device and instead require a padlock.

In addition, the electronic key system shall be used as the override cylinder on all comms room online access control installations, refer section 13.5.2 – Door requirements.

In all instances an online access control solution is preferred and every effort should be made to facilitate this. Usage of the CyberLock system within a security design requires approval by the University Security Manager.

13.5.2 Door Requirements

The following sections detail the security door hardware required for each type of door. The design consultant shall recommend the required door type for each access control point based on the outcomes of the security risk assessment. If a required door hardware configuration does not match any one of the door types, the design consultant shall consult the University's Security Office to agree with the proposed configuration.

It should be noted that not all door hardware (e.g. lever, handle, thumb turn, key cylinder, door seal, etc.) are included in the following sections. Door hardware is normally included in the door hardware schedule under the architectural package. The design consultant is required to coordinate with the Project Architect to ensure all security-related door hardware is included in the door hardware schedule.

Bottom rail locks and Euro cylinder are not to be installed.

Push and pull plates are the preferred mechanical hardware on doors secured by Mag Locks, additional door locks are not required.

Main Entry Doors

Where double doors are installed, the inactive leaf shall be secured with a lockable ADI panic bolt of no less than 300mm on the bottom of the door and a non-lockable panic bolt no less than 400mm on the top of the door. Alternatively a lockable ADI panic bolt can be installed at the top of the door of no less than 500mm in length. Lockable ADI panic bolts are to be keyed to the University restricted master key system, as nominated by the University Security Manager.

Standard Doors

FEATURES / HARDWARE	DOOR TYPE			
	A	B	C	D
ENTRY: Proximity card reader installed on the unsecured side of the door (See section 13.11.7)	X	X		
EGRESS: Proximity card reader installed on the secured side of the door (See section 13.11.7)	X			
EGRESS: Push button installed on the secured side of the door unless an electric mortice lock is used		X		
Electric door strike, electric mortice lock or magnetic lock. The Security Contractor shall select the appropriate door lock device to suit the specific door type	X	X	X	
Local door alarm sounder for DOTL and Forced Door alarms (except in biological resource facilities, unless approved otherwise)	X	X	X	X
Break glass door release unit. The break glass unit shall be installed on the secure side and shall be monitored	X	X	X	
Reed switch door monitoring	X	X	X	X
ADI lockable panic bolt on fixed leaf (where applicable)	X	X	X	
ADI or other University approved Blocker plate installed (where applicable)	X	X	X	X
Automatic door closer	X	X	X	X
Door status indicator			X	

Custom signage (where applicable)			X	
No external door furniture on external emergency exit doors			X	

- Type A Door (Full Access Control)

These doors shall have the following hardware/features:

- All Type A doors shall be controlled by Gallagher Controller 6000 Controllers.
- ENTRY: T15 Multi-Tech card reader installed on the unsecured side of the door (See section 13.11.7);
- EGRESS: T15 Multi-Tech card reader installed on the secured side of the door (See section 13.11.7);
- Electric door strike, electric mortice lock or magnetic lock. The University's preference is for electric door strikes to be used. The design consultant, in conjunction with the University's Security Manager shall select the appropriate door lock device to suit the specific door type;
- Break glass door release unit. The break glass unit shall be installed on the path of egress and shall be monitored;
- Reed switch door monitoring
- Local door alarm sounder for DOTL and Forced Door alarms;
- ADI lockable panic bolt on fixed leaf (where applicable);
- ADI or other blocker plate approved by the University's Security Manager (where applicable);
- Automatic door closer.

Each entry/egress card transaction at each door shall be logged as a separate transaction in the access control system database.

- Type B Door (Partial Access Control)

These doors shall have the following hardware/features:

- All Type B doors shall be controlled by Gallagher Controller 6000 controllers;
- ENTRY: T15 Multi-Tech card reader installed on the unsecured side of the door (See section 13.11.7);
- EGRESS: Push button installed on the secured side of the door unless an electric mortice lock is used;
- Electric door strike, electric mortice lock or magnetic lock. The University's preference is for electric door strikes to be used. The design consultant, in conjunction with the University's Security Manager shall select the appropriate door lock device to suit the specific door type;
- Break glass door release unit. The break glass unit shall be installed on the path of egress side and shall be monitored;
- Reed switch door monitoring;
- Local door alarm sounder for DOTL and forced door alarms (where applicable);
- ADI lockable panic bolt for fixed door leaf (where applicable);

- ADI or other blocker plate approved by the University's Security Manager (where applicable);
- Automatic door closer;

Any Partial Access Controlled Door shall be cabled such that a future upgrade to a Type A door shall not require any additional cabling between the security controller and the future egress T15 Multi-Tech card reader;

Each entry card and push button transactions at each door shall be logged as a separate transaction in the access control system database.

- Type C Door (Controlled / monitored / 24 Hour emergency doors)

These doors shall have the following hardware/features:

- All Type C doors shall be controlled by Gallagher Controller 6000 controllers
- Electric door strike, electric mortice lock or magnetic lock. The University's preference is for electric door strikes to be used. The design consultant, in conjunction with the University's Security Manager shall select the appropriate door lock device to suit the specific door type;
- Local door alarm sounder for DOTL and forced door alarms;
- Break glass door release unit. The break glass unit shall be installed on the path of egress side and shall be monitored;
- Reed switch door monitoring;
- Door status indicator;
- ADI lockable panic bolt for fixed door leaf (where applicable);
- ADI or other blocker plate approved by the University's Security Manager (where applicable);
- Automatic door closer;
- No external door furniture on external emergency exit doors;
- Custom signage;

Any Partial Access Controlled Door shall be cabled such that a future upgrade to a Type A door shall not require any additional cabling between the security controller and the future entry and/or egress T15 Multi-Tech card reader or push to exit button;

Each transaction shall be logged in the access control system database.

- Type D Door (Monitored Door)

These doors shall have the following hardware/features:

- All Type D doors shall be controlled by Gallagher Controller 6000 controllers.
- Reed switch door monitoring;
- Local door alarm sounder for DOTL and forced door alarms;
- ADI or other blocker plate approved by the University's Security Manager (where applicable);
- Automatic door closer

Each transaction shall be logged in the access control system database.

Special consideration shall be taken regarding doors of the following nature.

- Comms Room Doors

Access control door type A or B (minimum) fitted with Padde ES9000 and CyberLock key system as an override, as opposed to the traditional physical University master key system unless otherwise approved by the University's Security Manager.

- Plant Room Doors

Type B access control doors shall be nominated for plant room access control. The traditional physical University plant room master key system shall be used on all Plant and Comms risers unless otherwise approved by the University's Security Office.

- Biological Resource Facilities

Local alarm sounders and strobes shall be excluded from installation into these facilities unless otherwise approved by the University Security Manager.

- Electro-Mechanical Doors

The installation of an electro-mechanical operated door (e.g. main entry doors) shall meet Australian Standards AS5007 – 2007 & AS1428.

Where electronic access control is installed, the system shall be programmed to lock/open the main entry doors on the basis of a user defined time schedule. T15 Multi-Tech card readers shall allow access outside normal business hours. The high-level wiring configuration to achieve this has been illustrated in Appendix A – Automatic Door Wiring Diagram, of this section of the Design Standards.

Electro-mechanical doors shall provide:

- Audible alarm at the door for DOTL and forced door alarms;
- Monitored battery backup in the event of mains power failure. In the event of an electrical power failure, the battery backup system would keep the doors locked and secure;
- The ability to physically monitor the doors when open;
- The ability to physically monitor the doors when closed;
- The ability to monitor the status of the electric lock;
- Fail safe mode allowing a person to open the doors manually when there is a mains failure;
- Entry & exit radar detectors;
- Lock it Well K2 two position spring return key switch keyed to the University's master key system (IN);
- Lock it Well K4 four position key switch (auto/exit/open/locked) keyed to the University's master key system (OUT).

The electronic access control system shall interface with the door actuator at low-level via a relay. When access control functionalities are activated (e.g. during afterhours), the entry and exit radar detectors shall be deactivated accordingly.

The design consultant shall arrange for the University Security Office to supply the correct cylinder in the K2 (IN) & K4 (OUT) key switches prior to installation.

The door operator shall provide separate individual alarms to the security system (Gallagher Command Centre) when:

- there is a 240 volt power failure at the door;
- low battery voltage is detected at the door;
- there is a fault with the battery charger.

All alarms shall simultaneously be reported to the University's Security Office directly and appear at the Gallagher Command Centre Server & workstation to alert an operator.

- **Sliding Door (Non-auto)**

Non-automatic sliding doors should not be fitted with electronic access control devices, due to the ability for them to be left open and not automatically secure after use. Suitable Lockwood mechanical door locking hardware should be installed on any non-automatic sliding door.

- **Bicycle Hubs – Access Control:**

The following equipment shall be provided:

- T15 Multi-Tech card reader;
- Padde single magnetic lock;
- Door closer/Self closing hinges;
- IndigoVision IP digital CCTV camera, HD quality minimum;
- Break glass;
- Egress button;
- Black powder-coat pedestal to suit break glass & egress.

13.5.3 Electronic Intrusion Alarm System

Any Intrusion alarm systems installed at the University of Melbourne shall be based on Gallagher Controller 6000 equipment. The alarms are monitored from the University of Melbourne Security Control Room.

Specific requirements shall include (but not limited to) the following:

- Appropriate intrusion detection devices shall be placed at locations or areas identified in the risk assessment;
- The design consultant shall select the appropriate device types to meet the specific requirements;
- The Controller 6000 shall be programmed for event driven data transfer with the University's Gallagher Command Centre servers via the University's IP network. A TCP/IP port to be provided adjacent to the Controller 6000. The University Project Manager shall be responsible for acquiring an appropriate IP address from the University of Melbourne Security Office;
- Remote Arming Terminal (RAT) - all RAT's shall be the Gallagher T20 Multitech Reader device;

- Alarms shall sound locally and simultaneously be reported to the University of Melbourne Security Control Room;
- At each door, or where there is a passive infra-red detector in the area, a sounder shall be installed locally. When an alarm is triggered, the sounder shall go off, providing alarm signalling locally;
- All alarm inputs shall be terminated with end-of-line resistors recommended by the manufacturer;
- Each alarm device shall be wired to a separate input allowing each device to be monitored individually;
- Alarms shall be monitored for 4 states (i.e. normal, alarm, tamper (open circuit) and tamper (short circuit));
- Provide regulated power supply and battery backup of the intrusion detection system for 8 hours when there is a mains failure. Refer to section 13.1.11 for details;
- A Licensed and University approved structured cabling contractor shall be engaged to connect the intrusion alarm system to the Gallagher Command Centre management software by patching through the Security TCP/IP Network;
- Interface with the CCTV system allowing the cameras to be linked to alarm activations with pop-ups on high priority alarms.
- All inputs shall be named according to convention as per section 13.15;
- As required, alarm inputs shall be tied with outputs providing the capabilities to interface third-party systems or to switch on/off an alerting devices, e.g.:
 - After a DOTL alarm is acknowledged, the sounder shall be deactivated automatically;
 - When an alarm is triggered, switch on the lights installed within the alarmed area.

The design consultant shall discuss with the University Security Manager and other stakeholders to identify other specific requirements for implementation.

13.5.4 CCTV System

Operational requirements for each camera shall be developed in accordance with AS4806.1-2006 allowing field of view and detection grade to be specified, along with all other relevant Australian Standards, Codes and Authorities.

General Principles

The use of Closed Circuit Television (CCTV) equipment at the University of Melbourne is to assist security personnel to provide staff and students with a safe environment in which they can work and study. This is primarily achieved with CCTV through:

- Active observation;
- Providing a visual deterrent;
- The recording of images.

General Camera Requirements

- All power for University CCTV cameras shall be derived from the comms room to which it has been cabled back to. The use of local GPO's (general purpose outlets) to power CCTV cameras is not permitted;
- No camera will be fixed to a heritage building environment without the appropriate approvals;

- Planning and placement of all underground infrastructure, including pull boxes, must be approved by the University's Project Manager;
- Placement of external camera poles will be subject to agreement with the University Security Manager and Grounds Manager;
- As part of the installation commissioning process, all cameras must be adjusted (if required) to ensure the best possible picture is achieved during the hours of darkness;
- Wherever possible cameras will be placed at a height that allows them to be safely accessed for repairs and maintenance without the need for specialised access equipment;
- External cameras will be of a vandal proof design with no loose cables or easily vandalised mounting brackets;
- Traffic control zone cameras must be mounted so as to provide optimum views without impeding the flow of traffic or coming into contact with pedestrians or vehicles;

In accordance with applicable legislation, cameras will not be used to capture or view private activities unless clear and obvious signage is placed within the area in which the activities take place. Cameras will not be installed in private areas such as toilets or change rooms.

Camera Placement Requirements

The purchase or installation and placement of any security CCTV camera must be authorised by the University Security Manager.

Camera specification and location must be individually assessed based on the specific environmental conditions and desired purpose for the camera. CCTV system design and camera placement is to be based on industry best practice and be provided to the University Security Manager for review and sign-off.

All cameras designated to provide identification images must be situated between 2.4m and 2.8m from the fixed floor level.

Where possible, all cameras are to be mounted in such a manner, and at such a height, as to allow for ongoing maintenance without specialised equipment.

Recording Equipment

The IndigoVision Network Video Recorders (NVR's) shall be specified for recording CCTV cameras for security purposes.

Prior to installation of cameras, recording streams/licenses shall be confirmed with the University's Security Office.

Where any new installation requires additional recording capability additional NVR's may be required. Installations of four (4) or more cameras requires the installation of an NVR with sufficient capacity to record a minimum of eight (8) external cameras, of the same specification as those being installed.

It is the responsibility of the security contractor to ensure all new devices have the appropriate licences required to capture CCTV images onto the University of Melbourne's IndigoVision network.

All recording equipment shall be connected to the University of Melbourne network and configured to synchronize their clocks with the University NTP server.

Recording Requirements

All CCTV cameras shall meet the following recording requirements:

- Recording capacity: 30 days;
- Alarm / Event triggered recording: 25 fps;
- Recording format: H.264;
- All cameras shall record at a minimum of 4096 kbps upon alarm or event;
- All external cameras and entries to buildings shall record at 25 fps 24/7 at a minimum of 4096 kbps;
- All internal cameras (excluding entry points) shall record at 25 fps, 24/7 at a minimum of 4096 kbps during Alarm / Motion / Event triggered recording, but can otherwise be set to relevant ACF or background recording functions as mentioned above;
- All cameras shall be recording 24/7;

Camera Types

Cameras shall be compatible with the IndigoVision recorders and Control Centre management software. The preferred specification is for a suitable megapixel (MP) camera to be used. At a minimum, 1080p high definition (HD) specification cameras shall be used.

To be compatible with the IndigoVision recorders and Control Centre management software all cameras installed should be selected from the IndigoVision range of products or ONVIF compatible products certified as compatible by IndigoVision and approved for use by the University's Security Manager. All cameras shall be supplied with Enhanced Management Software license. All ONVIF cameras shall be supplied with appropriate licences to record to their designated NVR.

It is the responsibility of the security contractor to ensure all new devices have the appropriate licenses required to stream and record CCTV images onto the University of Melbourne IndigoVision network.

Dummy Cameras

Dummy cameras will not be used. It is the responsibility of the security contractor to ensure any newly installed device is operating and recording as soon as practical after its physical installation.

Operational Requirements

The University shall define the operational requirements for CCTV systems using the parameters set out in the Australian Standard AS4806.2-2006. The definition shall include:

- Coverage grade – identification, recognition, detection, monitoring and vehicle number plate visual recognition;
- Image size at maximum target distance – percentage of picture height;
- Field of view (FoV);
- Maximum target distance;
- Mounting height;

13.6 MECHANICAL SECURITY SYSTEMS

All mechanical locks (and associated keys) for doors, access hatches, services areas and the like, must be part of the University of Melbourne's restricted master key systems.

For all new buildings and refurbishments, the project team must provide a door hardware schedule to the University's nominated locksmith, who will provide a Keying Schedule

outlining the relevant locks and key hierarchy structure for sign off by the University's Security Manager and project team. The project team will be responsible for coordinating the keying requirements of all stakeholders, including the University's Security Office and providing this information to the University's nominated locksmith.

All door hardware must meet University Design Standards, as outlined in Section 5 (Building Fabric) and throughout this section.

13.7 EMERGENCY HELP POINTS (BLUE PHONES)

Blue Phones are an essential part of the University's safety offering and shall be considered as part of any security design. Consideration must be done in conjunction with the University Security Manager.

Blue Phones form part of the broader University security services and as such are not required as part of every project, however assessment and determination must be made on a project by project basis.

Current specifications can be requested from the University's Security Office.

13.8 LIGHTING

The main external entrance to a building shall be well lit after dark. Refer to Section 7 - Electrical Services for details of lighting controls.

At other perimeter doors and other ground level points of potential access shall be well illuminated by security lighting after dark as per the Australian Standards (AS/NZS 1158.3.1).

At locations or areas where digital recording CCTV cameras will be installed, the location or placement of light fittings will be critical. The security lighting from the building shall extend and integrate into existing light corridors such that continuous lighting of trafficable paths is maintained.

In order to allow high quality video image to be captured, the lighting level shall be a minimum of 15 lux at a horizontal level of 1.5 metres above the finished floor level. The contrast ratio between the maximum to minimum (average) lighting level shall be no greater than 1:3.

13.9 RADIO EQUIPMENT

Buildings with basement levels or underground car parks shall have a radio repeater installed to facilitate communications on the digital radio network in place at the University.

13.10 INTERFACE WITH THE FIRE PANEL

The Gallagher system shall interface with the fire panel at low-level via relay. When a fire alarm is triggered, a relay output shall be provided by the fire panel. When this relay output is received by the Gallagher Controller 6000 controller, the Gallagher Command Centre security management software shall display an alarm indicating that power to the door locks has been lost.

All electronic access controlled doors should release upon a fire alarm via this method, unless identified as a high-security door.

13.11 SECURITY EQUIPMENT (HARDWARE)

13.11.1 **Electric Door Strike**

Electric door strikes shall be PADDE ES 9000 or FSH FES90M-P. Blocker plates shall be installed on external doors to prevent tampering with electric strikes. Each door strike shall be complete with:

- Keeper security status monitoring (i.e. wired for both N/O & N/C);
- Each electric strike shall be configured for fail safe mode.

13.11.2 **Electric Mortice Lock**

- Electric mortice lock (with dead latch) shall be LOCKWOOD 3574 EL AM2R/L--SC. Each electric mortice lock shall be configured for fail safe mode;
- The mechanical override lock cylinder shall be keyed to the University Master key system;
- Cable transfer devices shall be specified as Lockwood LC8810 or LC8811 stainless steel concealed recessed flex conduit.

13.11.3 **Magnetic (Static) Locks**

- Magnetic locks shall be Lockwood PADDE Z8 monitored single or double electromagnetic lock or from the FSH ECO5700, FEM5700 monitored range;
- The design consultant shall obtain permission from the University Project Manager prior to specifying magnetic locks;
- Magnetic locks shall require separate power supplies each with battery back-up and failure monitoring, via interface to the Gallagher Command Centre management software;
- Each magnetic lock shall be fused individually.

13.11.4 **Controller Panels**

All new Security Controller panels shall be Gallagher Controller 6000 (C300100). The controller shall be connected to the security VLAN and shall communicate directly to Gallagher Command Centre Site Management Software.

Controller 6000's shall be housed within a Gallagher Cabinet or approved alternative within Comms rooms where one exists.

All panels shall have tamper status monitoring via mechanical switches in the cabinet, or via optical switches located on the Controller. Tamper alarms report to the University Security Control room.

For typical applications where Card Readers are required, The Controller 6000 will be expanded upon with a Gallagher 8H Module (C300182) or 4H Module (C300142).

13.11.5 **Controller Cabinets**

Controller equipment shall be housed within a Gallagher Dual Cabinet (C200104). Where space doesn't permit a Dual Cabinet, a Gallagher Single Cabinet (C200100) should be used.

All Gallagher cabinets must be installed with glands for cable entry and exit points, to maintain cabinet IP ratings.

All cabinets shall be keyed alike (refer to the University Security Office for keying instructions).

Where space is an issue, third party cabinets can be used, following approval from the University's Security Office.

Controller cabinets are to be labelled with the building code and controller number as per the naming convention specified in section 13.15.

When possible, GPO's powering the controller equipment and Network connection points shall be located immediately above the cabinet.

13.11.6 Expansion Interface Modules

Expansion Interface modules are used to add alarm monitoring points and output control points to the security system. Subject to the requirements of each project, the appropriate input/output modules shall be selected for the job.

Appropriate modules are:

-HBUS 16 In 16 Out Board (C300688)

-HBUS 8 In Board (C300680)

-HBUS 8 In 4 Out Board (C300684)

-HBUS 8 In 2 Out Door Module (C300660)

Expansion modules must be wired as per the manufacturer's requirements.

All Expansion Interface Modules shall be housed within a security cabinet that is monitored for tampering, as per section 13.11.4.

13.11.7 Access Cards, Card Readers and Exit Devices

Access Cards

Access cards (Staff, Student or Visitor cards) shall be issued by the University of Melbourne.

Card Readers

Gallagher T15 (C300480) Multi-Technology card readers shall be used on all new installations.

If the installation is part of an existing card reader system, the existing card readers and associated cabling shall be upgraded to the Gallagher T15 Multi-Technology card readers.

All card readers are preferred to be installed at a height between 1000-1200mm providing easy access to disabled persons.

Request-To-Exit Push Button

Where required, the design consultant shall specify Green mushroom head SEADAN SSE, 4350, DP/DT or similar as approved by the University Security Manager. The push buttons shall be installed at a height between 1000-1200mm adjacent to the controlled door.

13.11.8 Break Glass Units

Break glass release units shall be white in colour double-pole KAC WW2200/SW, SEADAN kw200/SW/B or similar approved by the University Security Manager. They shall be installed at a height of between 1000-1200mm adjacent to the secure side of the door.

When the glass is broken in an emergency, the controlled door shall:

- Unlock automatically (1st pole);

- Initiate an alarm (2nd pole).

All break glass units shall be monitored for tamper and shall be installed along the path of egress.

13.11.9 Duress Buttons

All new duress button installations must be accompanied by the installation of a CCTV camera, (see section 13.5.4). The location of the camera is to be confirmed with the University's Security Office prior to installation. Wireless duress buttons are generally not approved for use and are only to be specified with approval from the University's Security Manager in special circumstances.

Where required, the design consultant shall specify from the Honeywell 269R/270R/269SN Range of hold-up devices or alternative approved by the University Security Manager.

13.11.10 Door Monitoring

Reed Switches

SENTROL 1078 1" (one inch) reed switch shall be specified for all doors connected to the access control or intruder detection systems.

Each encapsulated reed switch shall consist of an individual magnet to be installed in the door leaf. Under normal situations, the magnet shall be installed at 100mm from the leading edge of the door. Whilst the switch and the end of line circuitry (EOL) shall be mounted in each door jamb head at the location matching the mounting location of the magnet.

The magnet to operate the reed switch shall be concealed by recessing into the door leaf and the gap between the reed switch and magnet shall not exceed 4.0 mm.

For wide gap and roller door applications, other reed switches would be required. The design consultant shall recommend a brand and model to suit the application to the University's Security Manager for approval.

For applications which require surface mount reed switches, the design consultant shall recommend a brand and model to the University's Security Manager for approval.

Door Status Indicators

Door status indicators shall be specified for all Type C doors. Each door status indicator shall consist of:

- Clipsal series 2000 plate;
- Green LED (engraved: 'Door Available');
- Red LED (engraved: 'Door Unavailable').

The design consultant shall specify custom mounting brackets where required.

Local Door Sounders

All local door sounders shall be Fulleon AWD sounder (RS Stock No. 626-141) or other as approved by the University's Security Manager. They shall be triggered via software programming and driven off a separate relay located on the same controller that the associated door is wired to.

The local door sounder shall be programmed so that it is silenced when the associated alarm is acknowledged by the control room operators.

13.11.11 DC Emergency Power Supplies

12-volt/24 volt DC battery backup regulated power supply and battery system shall be specified to maintain power to the electric locks and security systems (including access control, intrusion detection and CCTV systems) for an 8 hour period should normal "mains" power be disrupted. The backup power supply system shall be fully monitored by the Gallagher Command Centre security system.

13.11.12 240 Volt Power Supplies

All security panels and other equipment & devices shall be wired on circuits dedicated to security. A Lock-dog shall be installed on each associated circuit breaker. Each 240V GPO shall be labelled with "ESSENTIAL SECURITY EQUIPMENT DO NOT DISCONNECT".

13.11.13 Passive Infra-Red Detectors

Where required the design consultant shall specify from the Bosch Tritech range of PIR's, or other approved by the University's Security Manager. A dedicated Fulleon AWD sounder (RS Stock No. 626-141) or other as approved by the University's Security Manager should be installed per room with any PIR installation in the absence of access controlled doors in the area.

13.11.14 Glass Break Detector

Where required the design consultant shall specify from the Bosch DS110i Series Glass Break Detectors, or other as approved by the University's Security Manager.

13.11.15 Intercom System

Where required the design consultant shall specify from the 2N Intercoms IP range of equipment for intercom applications. All new intercoms must be added into the University's Cisco VOIP telephony system, 2N Access Commander system and any associated systems such as IndigoVision Control Centre, if required. Allowances for a 2N IP Gold License along with any other required licenses shall be made per intercom purchased.

13.11.16 Grey Boxes

All University of Melbourne buildings are required to have a University of Melbourne grey box installed for emergency service access. This includes all refurbishments and new building designs unless otherwise specified by the University's Security Manager.

Grey boxes are keyed to the University's electronic key system and are supplied by the University's Security Office. The following installation requirements apply;

- To be installed at main entry within one (1) metre adjacent to FIP or MIMIC panel whichever is applicable
- To be fixed at a height of 900-1200mm, preferably into a concrete pillar or similar strength location.
- To be fixed in such a manner as to be unable to be removed without accessing the inside of the grey box

The installation of a grey box is considered critical and must be completed prior to practical completion.

13.11.17 Key Switches

Where required, for electromagnetic doors and/or lifts or other applications, the design consultant shall specify that a Lock-it-well override key switch, with cylinder keyed to University master key system, shall be used. The following installation requirements apply;

- To be installed no more than one meter from door at a height of 900-1200mm unless otherwise approved by the University's Security Manager.

13.11.18 Condition of Equipment

All equipment supplied to the University must be new. The use of refurbished or second hand materials and parts is not permitted. Parts that include a manufacturers stamping must not exceed 18 months.

13.12 INSTALLATION REQUIREMENTS

All security installations shall be performed by businesses and individuals holding a Private Security License in accordance with the Private Security Act 2004 & Private Security Amendment Act 2010.

Electronic security devices shall only be installed and programmed by a specialist University of Melbourne approved Security Contractor. The Security Contractor must be Gallagher Command Centre accredited. Evidence of this accreditation shall be required prior to a log on to the management software is provided.

The design consultant must ensure that the project documentation includes a requirement that all installations are provided with a 12 month maintenance period from the date of practical completion.

Specific requirements shall include:

- The control of security devices shall be centralised via the Gallagher Command Centre site management software;
- Security data of all security devices shall be maintained in a single database (Gallagher database);
- The University requires that the Security Contractor shall be a direct Sub-contractor to the Builder - not to the Electrical Contractor;
- Graphical maps of the project area allowing icons of doors, break glass units, Gallagher panels, cameras, NVR's, remote arming terminals, PIRs, etc to be mapped.

13.13 SYSTEM PROGRAMMING

All programming into Gallagher Command Centre is to be completed by the University's nominated Gallagher programming contractor, and is to be completed as per the details outlined in these Design Standards, including Appendix B. For details of the current University nominated contractor, please contact the Security Office. For details of the current University nominated contractor, please contact the Security Office.

- Established programming and naming conventions as advised by the University Security Office shall be followed for any new programming entered into the system.
- All Security Panels shall be located on the graphic maps, including non-functioning devices.
- Unless otherwise stated, access control doors shall be programmed with 2 x Access Zones (Entry/Exit).

- All cameras are to be programmed into Gallagher Command Centre with an icon placed on the graphical maps that allows the operator to view camera footage.
- All cameras are to be programmed into IndigoVision Control Centre, including all camera setup options, recording schedules, graphical mapping, surrounding camera locations and any other programming aspects in line with University programming requirements.
- All intercoms are to be programmed into 2N Access Commander, as well as any other associated system such as Gallagher Command Centre or IndigoVision Control Centre including icons placed on graphical maps that allows the operator to control intercoms.
- Where appropriate, alarm or events shall have camera associations mapped in programming, in that when an event occurs, the security operator is able to display the linked video footage at the time of the event. Such events include duress alarms, intercom calls, intrusion alarms, fire alarms, etc.
- The function of automatic arming & disarming and locking & unlocking of controlled/monitored doors shall be carried out individually via time zones.
- All doors shall be individually monitored for alarms and all transactions & events shall be logged in the access control system database.

During programming the security contractor shall confirm all system programming requirements with the University's Security Manager prior to completion.

13.14 GRAPHIC MAPS

Graphical maps are to be provided for all new building and refurbishment projects. These maps are to show the actual layout of internal walls and security devices. The Graphical maps should be provided in a tiered system (Home > Campus > Precinct > Building > Building Level) to allow for navigation to each security devices located on the building level.

The building level should include navigation buttons allowing the user to move to each level of the current building and to adjacent internal views of the same building (where applicable).

Graphic maps should be taken from the University's Archibus (Spatial Information Portal SISfm) system and imported into Gallagher Command Centre and IndigoVision Control Centre with a portion of the map describing the Building Number, Building Address, Level, Data Source and date of import of the image. (i.e. 203 - 215 Grattan Street Level 1 - SISfm – 1/1/2017).

13.15 NAMING CONVENTION

Security devices should be programmed using the following naming conventions for each device, as outlined.

Device Type	Device Acronym	Naming Convention	Example
Controller 6000	FT####	Bldg# - FT# "DeviceType" Location	203 - FT0001 L01 Comms Room
Expansion Board 8In/4Out	8IO#	Bldg# - FT# "DeviceType" BUS# Location	203 - FT0001 8IO0 L01 Comms Room
Expansion Board 16In/16Out	16IO#	Bldg# - FT# "DeviceType" BUS# Location	203 - FT0001 16IO1 L01 Comms Room

Expansion 8 In 2 Door Module	2DM#	Bldg# - FT# "DeviceType" BUS# Location	203 - FT0001 2DM2 L01 Comms Room
Remote Arming Terminal	RAT	Bldg# - "DeviceType" "BldgLvl" Description	177 - FT0008 RAT L03 Special Collect 1
Door	DR	Bldg# - "DeviceType" "BldgLvl" Description	387 - DR GND East Store Rm Ent
Door - Reedswitch (Access Controlled)	RSA	Bldg# - "DeviceType" "BldgLvl" Description	387 - RSA MEZ East Store Rm Ent
Door - Egress	E/G	Bldg# - "DeviceType" "BldgLvl" Description	387 - E/G B01 East Store Rm Ent
Elevator (Lift)	LFT	Bldg# - "DeviceType" "Lift#" Description	387 - LFT1 Passenger High Rise
Elevator Floor	FLR	Bldg# - "DeviceType" "BldgLvl" "Lift#" Description	387 - FLR L01 LFT1 Passenger High Rise
Elevator Floor Access Zone	ACZ FLR	Bldg# - "DeviceType" "BldgLvl" "Lift#" Description	387 - ACZ FLR L01 LFT1 Passenger High Rise
Card Reader	C/R	Bldg# - "DeviceType" "BldgLvl" Description	387 - C/R Gnd East Store Rm Ent
Access Zone Standard	ACZ	Bldg# - "DeviceType" "BldgLvl" Description	387 - ACZ GND East Store Rm Ent
Access Zone "IN"	ACZ	Bldg# - "DeviceType" "BldgLvl" Description IN	387 - ACZ MEZ East Store Rm Ent IN
Access Zone "OUT"	ACZ	Bldg# - "DeviceType" "BldgLvl" Description OUT	387 - ACZ B02 East Store Rm Ent OUT
Input - Reedswitch Only Door	RSO	Bldg# - "DeviceType" "BldgLvl" Description	387 - R/S GND Reception To C/Park
Input - Duress	DURESS	Bldg# - "DeviceType" "BldgLvl" Description	387 - DURESS L06 Reception
Input - Break Glass	B/G	Bldg# - "DeviceType" "BldgLvl" Description	387 - B/G GND Main Entry Auto Dr
Input - PIR	PIR	Bldg# - "DeviceType" "BldgLvl" Description	177 - PIR L03 Stacks Main Corridor
Input - Power Supply Monitoring	PSU	Bldg# - "DeviceType" "BldgLvl" Description	310 - PSU GND Comms Rm
Input - Battery Monitoring	BAT	Bldg# - "DeviceType" "BldgLvl" Description	310 - BAT GND Comms Rm
Input - Glass Break	G/B	Bldg# - "DeviceType" "BldgLvl" Description	487 - G/B GND Office Window
Input - General Fire Alarm	GFA	Bldg# - "DeviceType" "BldgLvl" Description	187 - GFA GND Gate Keepers Cottage
Input - Miscellaneous		Bldg# - "DeviceType" "BldgLvl" Description	387 - FIRE ALARM GND Computer Lab
Relay - Electric Mortice Lock	LKE	Bldg# - "DeviceType" "BldgLvl" Description	177 - LKE L03 West Door
Relay - Strike Lock	LKS	Bldg# - "DeviceType" "BldgLvl" Description	185 - LKS GND Office Door
Relay - Magnetic Lock	LKM	Bldg# - "DeviceType" "BldgLvl" Description	185 - LKM L07 Office Door
Relay - Roller Door	LKR	Bldg# - "DeviceType" "BldgLvl" Description	185 - LKR GND Office Door
Relay - Bollard Lock	LKB	Bldg# - "DeviceType" "BldgLvl" Description	185 - LKB L12 Office Door
Relay - Auto Door	LKA	Bldg# - "DeviceType" "BldgLvl" Description	185 - LKA GND Office Door
Relay - Buzzer / Sonalert	BUZ	Bldg# - "DeviceType" "BldgLvl" Description	192 - BUZ GND Comms Rm 168
Relay - Strobe	STR	Bldg# - "DeviceType" "BldgLvl" Description	177 - STR L13 Fire Strobe
Alarm Zone	A/Z	Bldg# - A/Z Description	903 - A/Z Burnley Engineering
Site Plans		Bldg# - Address - Lvl	387 - 13-21 Bedford St - GND
Schedules		Bldg# - "Time Range" "Day Range" "BldgLvl" Description	203 - 0700-1700 MO-SA GND Entry Door
Camera - External		Bldg# - Ext Location Description "PTZ"	387 - Ext Main Entry 387 - Ext N/W PTZ

Camera – Internal		Bldg# - "BldgLvl" Location Description "- Rm#" "PTZ"	387 - L01 Foyer 387 - L03 Meeting Room - Rm 3.58
NVR		Bldg# - "BldgName" "NVRType" "#"	192 - Physics NVR1 192 - Physics WinNVR2

Common Abbreviations			
Building Level		Cardinal Points	
<i>Abbrev</i>	<i>Name</i>	<i>Abbrev</i>	<i>Name</i>
B02	Basement level 2	North	North
B01	Basement level 1	East	East
GND	Ground	South	South
GND MEZ	Ground Mezzanine	West	West
L01	Level 1	N/E	North East
L01 MEZ	Level 1 Mezzanine	S/E	South East
L02	Level 2	N/W	North West
L03	Level 3	S/W	South West
L04	Level 4		
L05	Level 5	Room Numbering Examples	
L06	Level 6	<i>Abbrev</i>	<i>Name</i>
L07	Level 7	Rm	Room
L08	Level 8	G.01	Ground room 1
L09	Level 9	1.06	Level 1 Room 6
L10	Level 10	E2.04	East Wing Level 2 Room 4
L11	Level 11	B.76	Basement Room 76
L12	Level 12		
L13	Level 13		
ROOF	Roof		
EXT	External		

Any device that is required to be programmed into multiple databases shall conform to the naming conventions listed above and shall be the same in both systems. Any modifications to the name of a device in the primary alarm monitoring suite shall also be reflected in any additional database the device is listed in.

13.16 CABLING

- No end device should be wired to a Controller located in another building;
- All cabling shall follow the manufacturer's recommended cabling standards.
- GBUS/HBUS cabling must be polarized and must be terminated using a 120-ohm resistor, jumper or termination wire at the last unit. The termination jumper on either the GBUS/HBUS circuit needs to be fitted if the Controller 6000 is the end device for this circuit or the communication port is not in use.
- All terminations into control equipment shall be provided with Ferrules (Boot Laces) sized appropriately for the cable.

- Cables shall not be joined or extended.
- The cabling from the Controller 6000 to the readers shall be a minimum 4-core (14/0.20mm²) cable with cable runs not exceeding 150m as per manufacturer's specifications;
- There is to be a maximum of 10 access controlled doors installed on each Controller 6000 processor;
- UOM installation practice is to have only 1 card reader wired back per HBUS port, where there is an IN/OUT card reader configuration, 2 readers on the one HBUS line is accepted;
- Figure 8 cable (min 24/0.20mm²) shall be used on electric strike and mortice locks;
- Figure 8 cable (min 26/0.30mm²) shall be used on electromagnetic locks, where double-electromagnetic locks are used, 2x Figure 8 cables shall be used; All Break Glass Units, Egress Buttons, Duress Buttons, Reed Switches, Local Sounders, PIR's and Door Status Indicators shall use 4-core (min 14/0.20mm²) cable;
- All alarm monitored inputs shall be installed with 2x 10k ohm end-of-line resistors at the field device, to allow for monitoring of the following input state conditions: Open / Closed / Short Circuit (Tamper) / Open Circuit (Tamper);
- Any network cabling shall not exceed 90m from point-to-point;
- There is to be no more than 10% in voltage drop for any ELV power cable;
- Refer to section 8.3.7 of the Design Standards for wall penetration requirements.

The security contractor shall submit samples (with technical product data sheets) of all cable types for approval by the University's Security Manager.

13.17 NETWORK INFRASTRUCTURE

The security systems operate on the University Network. Accordingly, the Contractor shall:

- Be appropriately certified, if not certified the Security Contractor must engage a contractor from the University's preferred contractor list;
- Provide structured cabling including all required patch panels, data outlets, etc.;
- Certify all new network cabling and patching as per University's Standards for the Installation of Communications Infrastructure, which can be accessed from the Design Standards web page;
- Network switches will be supplied and configured by the University;
- Provide all required patch cords and fly leads as per the University's Standards for the Installation of Communications Infrastructure, which can be accessed from the Design Standards web page;
- Coordinate connection to and configuration of the active network equipment;
- Notify the Project Manager of additional network switches and related details 4 weeks before hardware is required;
- All security equipment shall reside on the Security VLAN as per IP addresses allocated by the University Security office.

13.18 **SYSTEM TRAINING, AS-BUILT DOCUMENTATION AND OPERATION & MAINTENANCE MANUALS**

The security contractor is required to provide the following to the University:

- System training to the operators. The security contractor shall liaise with the University Security Manager to identify the training needs including breakdown of the training into levels to meet the operational requirements and the preparation of training materials. Training is to be completed seven (7) days prior to handover;
- As-built documentation – the security contractor shall prepare the as-built documentation to document the as-installed status of the security systems. This shall include (but not limited to the following):
 - As-built layout drawings;
 - As-built cable schedules;
 - As-built schematic wiring diagrams;
 - As-built cable reticulation and conduit layout;
- O & M manuals – the security contractor shall prepare the O & M manuals to document the following:
 - Product data sheets;
 - Operating procedures of the security systems;
 - Maintenance procedures of the security systems;
 - User guide;
 - Call-out procedures;
 - Troubleshooting guide;
 - Warranties;
 - Test results;
 - Final commissioning checklist;

Draft copies of O & M manuals are to be provided at a minimum of four (4) weeks prior to practical completion, with final versions provided no later than four (4) weeks post project practical completion.

The design consultant must include all these requirements in the specification.

13.19 **TESTING & COMMISSIONING**

Testing & commissioning shall be a two-stage process. The security contractor shall undertake internal testing to check the functionalities of every device and equipment against the performance of the security systems specified in the specification. The test results shall be recorded in test results record sheets, which shall be submitted to the design consultant for review and approval.

The security contractor shall also submit a test plan to detail the steps or procedures to verify the performance of the security systems against the specification. The test plan shall be submitted to the design consultant for review and approval. The approved test plan shall become the reference document for final commissioning.

The test plan shall cover (but not be limited to):

- The verification of all system functions and facilities sufficient to demonstrate the correct installation and operation of the system as a whole;

- Both night and daytime tests as applicable to the system components;
- Operational tests designed to verify the operation of all aspects of the system, together with the interfaces between the various security sub-systems and any non-security systems e.g. Fire Panel.

The test plan shall be thorough in its testing and recording, and shall effectively demonstrate all performance and operational aspects of the specified security systems. The form of the document shall be mainly a check sheet of system operations, functions and facilities with space to insert numerical values where applicable. A separate column or space shall be provided for comments to be inserted.

Upon the approval of the test results & the test plan and the security contractor is satisfied that the security systems are ready for final commissioning, the security contractor shall organise with relevant stakeholders (including representatives from the University's Security Office and design consultant) to witness the final commissioning of the systems.

The security contractor is to provide at least two persons to conduct the final commissioning and hand-held radios such that they may carry out tests and demonstrations in accordance with the test plan for relevant stakeholders to witness. In the case of CCTV testing, supply all test targets and recording equipment as may be necessary for the tests. The security contractor shall note that final adjustment on cameras (e.g. focus, angle of view and field of view) may be required to achieve the operational requirements.

With the security contractor undertaking internal testing before final commissioning, it is expected that tests can proceed without delays due to wiring errors or poor adjustment.

As part of the testing & commissioning process, the security contractor shall note that a copy of the final camera view (after final adjustments) for each camera shall be printed. The copy shall form part of the as-built documentations. The print out of the camera view shall be the reference for the maintainer to adjust the camera view after maintenance works.

The design consultant shall include all these requirements in the specification.

13.20 NOTICE OF COMPLETION

The security contractor is to ensure that the security systems are completed and commissioned prior to practical completion. This process shall not be considered complete until the nominated University Security representative, has signed off that they are satisfied with the installed systems and they are ready to operate.

The design consultant shall be responsible to witness the final commissioning of the security systems and prepare the final acceptance certification of the completed installation. Upon satisfactory completion of the project the design consultant shall forward the completed test results to the University Project Manager and the University's Security Office.

13.21 DESIGN CHANGE AUTHORISATION

All requests for changes to the requirements of the Design Standards must be made on the Modification Request Form. No design work is to proceed on the basis of the proposed modification until the modification request has been approved in writing.

13.22 APPENDICES

13.22.1 Appendix A – Automatic Door Wiring Diagram

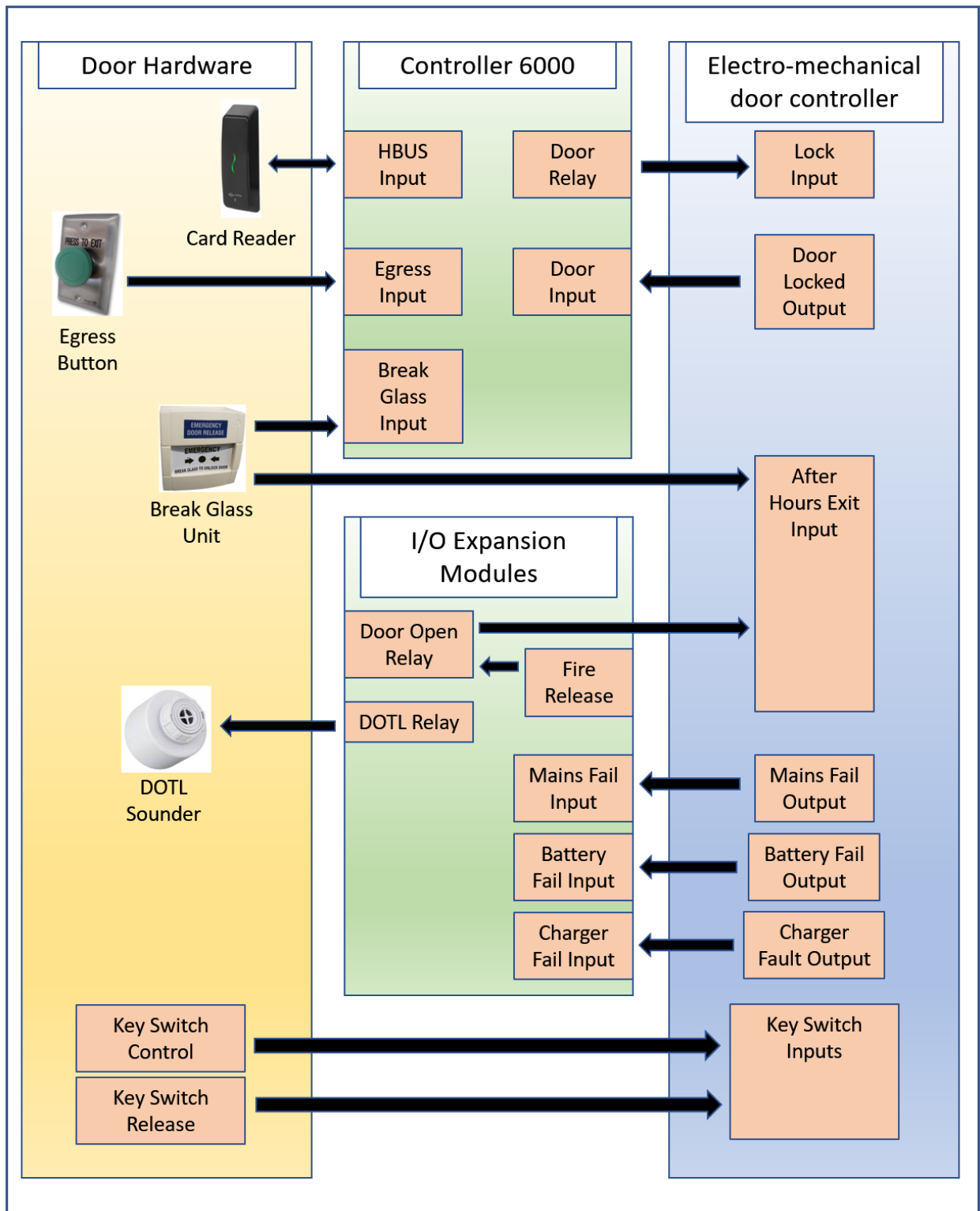

13.22.2 Appendix B – Contractor Programming Requirements

Workshare Arrangement for Commissioning of Gallagher Access Control System for the University of Melbourne

The purpose of this document is to establish a workshare arrangement between security sub-contractors for the delivery of Gallagher Access Control and Intrusion Systems throughout The University of Melbourne. It is intended to provide clear direction on the responsibilities of each contractor when delivering access control and intrusion detection installation works for the University of Melbourne.

Installation Contractor (“IC”) – The contractor responsible for the cabling, fit-off of end devices, fit-off of panels, coordination of network and power and pre-commissioning of hardware.

Commissioning Contractor (“CC”) - The contractor responsible for the programming and commissioning of software and configuration of the system.

Prerequisites

All contractors must be on the University of Melbourne’s approved security contractor list. This list is available from the University’s Security Office upon request.

The University’s nominated Commissioning Contractor is MGA Electronic Security. Any installation of Gallagher Access Control and Intrusion Systems throughout The University of Melbourne, must be programmed into the University of Melbourne’s Gallagher Command Centre software by MGA Electronic Security.

Installation and commissioning of all equipment shall be in compliance with Section 13: Security of the University’s Design Standards document. This is available via <https://staff.unimelb.edu.au/contractors> or by contacting the University Security Office.

Installation Contractor Responsibilities

- Procurement of all hardware
- Installation of all cabling and hardware
- Panel fit-off
- Coordination of power
- Coordination with head contractor and third parties (including UoM) of network installation including;
- Patch leads
- Network points
- Coordination with UoM IT for the availability of network switches and ports
- Pre-commission all end points, including completed and signed test plans.
- Note: For devices that require software (readers/controllers), it is expected that the Installation Contractor can confirm the device powers up.
- Terminate and test fire interface and relays.
- Final commissioning of all points alongside Commissioning Contractor. This will require an Installation Contractor technician in the field, working with the Commissioning Contractor technician.
- Provide all necessary documentation (drawings/point schedules/schematics) and other contractual requirements as issued by a Head Contractor or the University of Melbourne.

- Provide final install marked up plans, a schedule of points and any other pre-agreed documentation to the Commissioning Contractor, at a reasonable time prior to commissioning, to enable the Commissioning Contractor to program the system.
- Provide reasonable notice to the Commissioning Contractor for commissioning works. Reasonable cooperation is expected between both Installation and Commissioning Contractors to make these arrangements.
- Schedule commissioning for Buildings/Areas/Level in such a way to minimize repeated attendances for commissioning of small areas or single devices/doors.
- Warrant all hardware, cabling and installation works for a minimum 12 months.

Commissioning Contractor Responsibilities

- Procurement and implementation of all licenses and software.
- Coordination with UoM on access zone and alarm zone programming.
- Coordination of network port programming with UoM IT.
- Programming of all inputs, outputs, doors, access groups and end devices into the Gallagher database.
- Programming of site plans and icons.
- Programming and commissioning of visitor management system (where required).
- Integration with other security sub systems (i.e. Keysafes, CCTV)
- Final commissioning of all points, alongside Installation Contractor. This will require a Commissioning Contractor technician working with the Installation Contractor technician in the field.
- Provide commissioning services at the request of the Installation Contractor, provided reasonable notice is given. Reasonable cooperation is expected between both Installation and Commissioning Contractors to make these arrangements.
- Warrant all software, firmware and configuration for a minimum 12 months.

Both the Installation Contractor and the Commissioning Contractor MUST sign-off on the notice of completion of works, before submission to the Head Contractor or University of Melbourne and acceptance that the works are complete.

Integrations and other non-standard functions

Any non-standard functions such as high level integrations to other systems will need to be coordinated separately between UoM the Installation Contractor and the Commissioning contractor.

SECTION 14: TRAFFIC AND PARKING

CONTENTS

14.1	INTRODUCTION	2
14.2	PARKING SIGNAGE.....	2
14.3	BOLLARDS	2
14.4	TRAFFIC LIGHTS	3
14.5	BOOM GATES	3
14.6	PARKING PAY STATIONS.....	3
14.7	PARKING BAYS	4
14.8	SPEED HUMPS.....	4
14.9	REFERENCES	5
14.10	AS-BUILT DOCUMENTATION.....	5
14.11	DESIGN CHANGE AUTHORISATION.....	5

14.1 INTRODUCTION

This section of the Design Standards provides details of the University's minimum requirements for traffic and parking. Consultants are to produce their own specification incorporating this and other sections of the Design Standards as well as the requirements of all relevant legislation, regulations, codes and standards.

Consultants must use the Modification Request Form to obtain approval for any proposed departure from the Design Standards. No design work is to proceed on the basis of a proposed modification until the modification request has been approved in writing.

All project documentation is required to be submitted to the University Project Manager for review prior to tendering.

14.2 PARKING SIGNAGE

All parking signs shall be clearly sign-posted in accordance with AS 1742.11 and the Road Safety Rules 2017. Signs at the main entries to car parks and University campuses shall have the following additional messages:

- The type of parking restrictions that apply;
- That vehicle parking on the campus is subject to the Road Safety Act 1986 (Vic);
- That penalties apply for unauthorized parking;
- That vehicles must only be parked in marked bays;
- That drivers enter the campus and use the car parks at their own risk and that the University does not accept any liability for loss or damage to, or theft from, vehicles;
- That motorcycles must be parked in designated bays;
- That bicycles must be secured to the hoops provided;
- The designated speed limit for the area.

14.3 BOLLARDS

Bollards are primarily used for traffic control and property protection.

Fixed bollards are, as a minimum, to have the following features:

- Cylindrical shape of 160mm diameter and 900 mm in height;
- Stainless steel construction;
- Cylinder fixed into a removable stainless steel tube;
- Suitable for installation into any concrete surface;
- A 50mm in height reflective band around top of post;
- Removable bollards are to be lockable with manual key lock consistent with the University master key management system.

Rising bollards shall have the following minimum features:

- Cylindrical shape of 275mm in diameter and 600 mm in height;

- Stainless steel construction;
- The cylinder is to be visible in all environmental conditions. It is to incorporate a 55mm high reflecting strip all around the cylinder and LED lights that flash red when the bollard moves and stay permanently ON when the bollard is raised.
- Traffic flow must be controlled by traffic lights;
- VoIP intercom connected to University network;
- Access control card reader connected to the University network and security systems to meet University Design Standards Section 13: Security;
- Vehicle detectors loop systems.

The project specification shall be tailored to the specific needs of the job. The consultant is to discuss the requirements with the University Physical Security Manager.

14.4 TRAFFIC LIGHTS

Traffic lights shall have the following features:

- Alternating red/green LED lights on two opposite sides;
- Pole mounting should be three meters in height;
- Bolted above ground to a concrete pad (minimum size 500mm x 500mm);
- Shall be connected to the bollard operation or used for the control of competing flows of traffic.

The project specification shall be tailored to the specific needs of the job. The consultant is to discuss the requirements with the University Physical Security Manager.

14.5 BOOM GATES

Boom gates shall have the following features:

- Controlled by the University network and security systems to meet University Design Standards Section 13: Security;
- In ground vehicle detection loops to protect vehicles as well as to allow vehicles to freely exit the carpark;
- Must have automatic powered operation;
- Brand is consistent with University preferred supplier;
- Red and white diagonal stripes;
- Constructed of fiberglass or lightweight metal;
- Connected to the University network and security systems to meet University Design Standards Section 13: Security;

The project specification shall be tailored to the specific needs of the job. The consultant is to discuss the requirements with the University Physical Security Manager.

14.6 PARKING PAY STATIONS

Parking pay stations shall have the following features:

- A choice of credit card, electronic funds transfer at point of sale (EFTPOS) or cash handling payment methods;

- Software system available to indicate logging of transactions, errors, warnings, and electronic access to allow precise tracking of different events;
- Alarm connected to the University network and security systems to meet University Design Standards Section 1: Security to identify unauthorized access;
- Disability friendly design;
- LED large display or screen;
- A cash vault that is accessed via one door while the main serviceable components are accessed via a separate door;

The project specification shall be tailored to the specific needs of the job. The consultant is to discuss the requirements with the University Physical Security Manager.

14.7 PARKING BAYS

Off-street parking shall conform to AS/NZS 2890.1 Parking Facilities - Off-street car parking.

On-street parking shall conform to AS/NZS 2890.5 Parking Facilities - On-street car parking.

Provision of parking spaces for people with disabilities shall conform to AS/NZS 2890.6 Parking Facilities - Off-street Parking for People with Disabilities.

Off-street commercial vehicle shall conform to AS/NZS 2890.2 Parking Facilities – Off-Street Commercial Vehicle Facilities.

The following are the minimum requirements for off and on street parking bay sizes at the University:

- Standard car bay – minimum 2.3m by 6m;
- Disabled car bay – minimum 3.5 by 6m;
- Space between bays rows – minimum 7.5m.

Parking bays shall be clearly line marked to conform to AS/NZS 2890.1

14.8 SPEED HUMPS

Speed humps shall conform to AS/NZS2890.1. The project specification shall be tailored to the specific needs of the job. Speed humps shall have the following features:

- Speed humps shall be made suitable for traffic conditions;
- Appropriate for use on long aisles and circulating roadways in outdoor surface and car parks to check the speed of vehicles travelling at 30km/h or less;
- Speed hump marking shall be black and yellow in colour and visible to drivers;
- Speed humps shall not impede pedestrians or wheelchair traffic on any accessible travel path provided for people with disabilities;
- Preference to 'flat-top' speed hump heavy duty and highly durable, installed with dynabolts for concrete and hex anchor bolts for bitumen applications, and easily removable;

The project specification shall be tailored to the specific needs of the job. The consultant is to discuss the requirements with the University Physical Security Manager.

14.9 REFERENCES

Road Safety Act 1986 (Vic).

AS 1742.11 Manual of Uniform Control Devices: Parking Controls.

AS 1742.11 Road Safety Road Rules 2009.

AS/NZS 2890.1 Parking Facilities - Off-street Car Parking.

AS/NZS 2890.5 Parking Facilities - On-street Parking.

AS/NZS 2890.6 Parking Facilities - Off-street Parking for People with Disabilities.

AS/NZS 2890.2 Parking Facilities - Off-street Commercial Vehicle Facilities.

14.10 AS-BUILT DOCUMENTATION

As-built documentation, operation and maintenance manuals, guarantees, warranties and other related information is to be provided to the University. Draft documentation is to be provided four weeks prior to practical completion and final form documentation is to be provided no later than four weeks after practical completion.

The University of Melbourne CAD Standards detail the formatting and submission requirements for as-built drawings, manuals and warranties. The CAD Standards can be found in the Associated Documents Section of the Design Standards web page.

14.11 DESIGN CHANGE AUTHORISATION

All requests of changes to the requirements of the Design Standards must be made on the Modification Request Form. No design work is to proceed on the basis of the proposed modification until the modification request has been approved in writing.

**SECTION 15: GROUNDS AND LANDSCAPING
CONTENTS**

15.1	INTRODUCTION	2
15.2	SCOPE	2
15.3	STANDARDS AND REGULATORY REQUIREMENTS	2
15.4	REFERENCE MATERIAL	2
15.5	SITE APPRECIATION AND DESIGN PRINCIPLES	3
15.6	LANDSCAPE PROTECTION	5
15.7	EARTHWORKS	6
15.8	SOFT LANDSCAPING	8
15.9	HARD LANDSCAPING	9
15.10	ROOFTOP WORKS	9
15.11	WATER SUPPLY AND IRRIGATION	10
15.12	DRAINAGE	12
15.13	LIGHTING	13
15.14	LANDSCAPE FURNITURE	13
15.15	DEFECTS LIABILITY PERIOD	13
15.16	DESIGN CHANGE AUTHORISATION	13
15.17	AS-BUILTS, WARRANTIES AND MANUALS	13
15.18	APPENDICES	13

15.1 INTRODUCTION

The University of Melbourne is recognised for the quality of its landscape and external environment. The University's on-going objective is to ensure that all new landscape areas provide visually pleasing places for campus users to meet, study and relax.

Landscape designers are required to meet the minimum standards nominated and to ensure that the overall design integrates well with the existing landscape.

The standards focus on maintaining design cohesion by providing a consistent pallet of linking elements to connect disparate buildings and structures throughout the campus. It is important that designers ensure that the landscape design is fully integrated with the design of related new built infrastructure.

The design of landscape projects must consider, to the maximum extent possible, the following factors:

- Safety in design
- Water sensitive urban design
- Sustainability and biodiversity
- Solar screening and access
- Pedestrian and traffic flows
- Noise reduction and privacy
- Maintenance of desirable sightlines
- Definition of borders between facilities
- Visual stimulation and creation of interest
- Reduced maintenance costs and vandal proofing

15.2 SCOPE

This section covers the following grounds and landscape requirements:

- Design principles
- Asset protection
- Hard and soft landscaping elements
- Services and,
- Establishment and maintenance

The following design considerations and elements are detailed in elsewhere in the Design Standards:

- Road and pavement sub base
- Bollards
- Water supply
- Security Help Points
- External drinking fountains
- External lighting

15.3 STANDARDS AND REGULATORY REQUIREMENTS

Design and documentation is to fully comply not only with the Design Standards but also with all relevant Acts, Codes, Regulations and Australian Standards. Any relevant landscaping good practice guidelines should also be complied with. Any inconsistency between these documents is to be notified to the University's project manager.

15.4 REFERENCE MATERIAL

- o Campus)

- National Trust Register of Significant Trees (refer link in section 15.5)
- City of Melbourne Register of Exceptional Trees (refer link section 15.5)
- University of Melbourne Urban Forest website (refer link in section 15.5)

15.5 SITE APPRECIATION AND DESIGN PRINCIPLES

The University of Melbourne's landscaping philosophy stems from a long history dating back to its establishment in 1853. At the Parkville campus, heritage landscapes such as the System Garden, South Lawn and the collection of mature trees are integral to the University's external fabric. The mid twentieth century expansion of the University saw a series of distinguishable courts and connecting lanes emerge that command their own unique quality. This distinctive feature of the University of Melbourne is to be retained and continued as new landscape works are undertaken.

The result is a diverse natural environment that is realised from old traditions blended with modern approaches. A key feature at Parkville is that the campus landscape integrates aesthetically with buildings whilst aiding and facilitating the logical and safe movement of students and staff.

What the University requires from future landscape designs is the preservation of important landscape areas and attributes as well as a continuance of the blending of one area of landscaping to the next. With the exception of zones which the University may nominate as requiring a unique landscape treatment, the University requires the continuation of its overall landscape concept. On occasion, the University may be amenable to new concepts, particularly ones which acknowledge changing climate conditions. However, overall design cohesion and adherence to the detailed information contained in the Design Standards is required.

The University recognises the importance of sustainable practices and, in particular, biodiversity as detailed in the Biodiversity Management Plan.

https://sustainablecampus.unimelb.edu.au/_data/assets/pdf_file/0011/2315819/Biodiversity-Management-Plan-2017.pdf.

Landscape consultants and designers are encouraged to pursue increased biodiversity whenever opportunities present themselves.

The University's significant tree collection is a valuable feature of the Parkville campus and includes trees on the National Trust Tree Register and the City of Melbourne's Exceptional Tree Register.

<https://sustainablecampus.unimelb.edu.au/key-areas/campus-grounds/urban-forest-data>

<https://www.nationaltrust.org.au/services/significant-tree-register/>

<http://www.melbourne.vic.gov.au/community/parks-open-spaces/tree-protection-management/pages/exceptional-tree-register.aspx>

Designs which impact either physically or visually on significant trees are to be avoided.

Design for external areas should provide a diversity of space types (ranging from reflective spaces to those which encourage interaction) and that allow for spaces to function as living laboratories in support of teaching, learning and research.

Melbourne University campuses generally combine Australian native plants with complimentary exotic species. This sympathetic blending of species should be continued.

Where appropriate, distinct planting themes or character may be developed for new landscapes. Such themes might draw upon plant communities of a specific geographic region; be based on foliage / flower colour; plant forms, physiologies or properties; botanic classification; indigenous; culinary etc. Any theme devised for a new garden or precinct area is to be thoroughly discussed and tested in the project design phase. The Urban Forest Data webpage has layers displaying the current distribution of tree species, habit and origin. These may help in identifying existing themes across the landscape and help new landscaping tie in with its existing surrounds.

Mass planting is encouraged and is appropriate for large open spaces. An appropriate balance is to be achieved between areas of garden planting and occupiable space such as lawns according to expected levels of usage. Landscape design plans should at the same time seek to maximise use of vegetation and green space, whether garden, trees or lawn, to maintain and extend where possible the concept of a campus in a garden or park setting.

Desire lines of expected pedestrian movement across landscape space should be identified and allowed for. Garden beds should not be positioned so as to obstruct desire lines or hamper ease of movement around the campus. Consideration must be given to protection of sensitive landscape areas by creation of designed barriers which may include hedges, densely planted garden beds, retaining walls, furniture, water features or similar.

Plant selection should be principally based on use of trees, shrubs, grasses and strappy-leaved plants, and groundcovers. Perennials should be restricted to use as accent plants only, and in limited number, to reinforce and expand on an adopted theme. Ephemeral flowering annuals, bulbs and the like are to be avoided.

All plants should be selected for best suitability to the given landscape situation. Full account must be given to the aspect, sunlight levels, soil conditions including drainage, wind, natural rainfall patterns and the established planting character of adjacent areas.

Preference should be given to plant selections that are hardy, drought-tolerant, non-weedy or invasive, long-lived, low maintenance, resistant to pests and disease, and as free as possible of potential hazards.

Species selection, especially for large specimen trees in prominent locations, should take account of vulnerability to forecast climate change and extreme weather conditions in coming decades. Tree selection in such instances should only be for those species deemed to be suitably adaptable, tolerant and hardy over the course of their expected useful amenity life. The University's Urban Forest webpage contains tree temperature vulnerability assessment information which identifies the tree species which have been deemed vulnerable to future warming temperatures in Melbourne.

Tree choice should aim to increase overall canopy cover across the campus, so larger long-lived specimens should be selected by preference where the situation allows. Deciduous trees should be favoured where winter sunlight penetration is a clear advantage for year-round amenity of any space. If any canopy is removed during a

project, the same area should be planned for replacement by planting a new tree/s that once mature will reinstate or expand on the canopy cover area that has been removed.

Tree species known to cause allergies or regularly shed limbs must be avoided.

Climbing plants intended to cover building walls must have durable and adequate support structures installed to provide for growth and maintain wall adhesion. Climbing plants should only be used where there is sufficient access for appropriate equipment for on-going pruning and maintenance

Landscape and planting design must consider maintenance requirements into the future, aesthetic presentation and visual impact throughout all stages of growth to maturity, and any amenity issues or possible adverse implications for campus infrastructure.

The above provides only a short summary of the University's required approach to landscape design. Landscape consultants and designers are required to initiate early discussion with the University's Grounds Manager to ensure that a thorough understanding of the elements underpinning the University's landscape design philosophy is obtained.

15.6 LANDSCAPE PROTECTION

During the early design stages, the Consultant shall consult with the Grounds Manager and Biodiversity Co-ordinator or their nominees with regards to the impact of the proposed construction works on trees, shrubs and grounds within the construction site.

An assessment of each tree within the construction zone shall be carried out by the Grounds Section during the design process and any trees requiring protection will be nominated at this time.

Depending on the scale of the project, an external project arborist may need to be appointed by the Contractor to provide oversight and advice for tree protection throughout the project term. Such an appointment will be at the recommendation and approval of the Grounds Manager and all costs, including for recommended tree protection measures, will be included in the tendered/quoted project cost. Any reports generated by the project arborist will be made available to the Grounds Manager.

The University of Melbourne's buildings and grounds contain a large number of objects of cultural importance such as sculptures, facades, mosaics, heritage items etc. These belong to the various cultural collections of the University and are to be protected during works.

Protection and care of objects of cultural significance during works will be based on advice sought by the University's Project Manager from the University's Potter Museum of Art, the custodian of the University's cultural objects.

Individual objects of cultural significance are to be identified in tender documents and the specific nature of their protection and care during works is to be documented prior to site occupation. Site inspections may be made to ascertain compliance with protection of cultural materials.

The Contractor may be required to salvage valuable landscape items and materials for storage or reuse as part of early work for the project. The Grounds Manager or his/her nominee will give advice of any requirements

Damage to grounds, gardens, plant material, tree roots, paving, irrigation systems and outdoor furniture must be avoided. If damage does occur work must cease immediately and the matter reported without delay to both the relevant University Project Officer and the Grounds Manager

Any tree, group of trees or shrubs nominated in the tender documents as requiring protection must have suitable protection provided. This shall be in the form of a minimum 1.8m high fixed hoarding or chain-link fencing, complete with access gate to be erected, maintained and removed by the Contractor. The fence shall be placed at the outer edge of the TPZ or drip line of the tree(s) or shrubs, and shall serve as an exclusion zone for all construction activity. No building or construction material or liquid waste is to be stored or disposed of within the designated zone of protection, or other areas of garden. Tree Protection Zone signage shall be fixed to the fence, and shade cloth if stipulated.

Depending on the timeframe for the project (both duration and time of year) a layer of mulch or aggregate of between 50-100mm depth may be required around the tree within the protection zone, along with temporary irrigation.

Pruning of branches and / or roots and any removal of plants must only be carried out by the University's Ground Section or their nominated contractor.

The Contractor is required to consult with the Grounds Section at least 2 working days prior to the commencement of any excavation and / or construction in garden areas and tree root zones.

In the likelihood that activities associated with intended site works or construction would damage or remove significant portions of plant root zones anywhere within the project site, the Project Arborist and Grounds Manager or his/her nominee shall be advised and an appropriate course of action identified prior to works proceeding.

If the supply of water to either the landscape or, specifically, to irrigation systems, including landscape areas beyond the project site itself is to be disrupted for longer than one week, arrangements will be made by the Principal Consultant to install and manage a suitable temporary water supply system until such time as the infrastructure is repaired or replaced.

The Grounds Manager or his/her nominee may require a bank guarantee to the value of the nominated tree(s) on construction sites. Such a guarantee shall be held by the University in trust against damage and injury to the nominated tree(s) for at least the period of the construction defects period, or any longer period as judged to be necessary by the Grounds Manager or his/her nominee. The value of the tree will be determined by the University using the City of Melbourne's valuation methodology as a basis.

Note that any works which could adversely impact a registered significant tree (as listed on the City of Melbourne Register of Exceptional Trees) will require a planning permit.

Construction works and activities shall ensure appropriate hygiene practices are carried out to avoid transmission of soil borne disease which can threaten plant health. Contaminated material must be removed from site and all materials brought in must be clean. The Grounds Manager will give advice of any specific disease concerns for an area of the campus, and appropriate control measures are to be implemented by the Contractor.

Depending on the scale and location of the work, regular site inspections may be required by the Grounds Manager or his/her nominee. Any non-compliance will require work to cease until satisfactory rectification can be made.

The documentation for all projects is to include a requirement for the full reinstatement of the landscape to a standard at least equal to existing condition.

15.7 EARTHWORKS

Excavations and earthworks should be limited in order to avoid disturbance to adjacent landscape. Plant material, irrigation and other landscape objects are to be removed prior

by Grounds staff unless otherwise agreed by the Grounds Manager. Hard surface materials to be salvaged shall be removed without damage by the Contractor and put aside or into storage.

Checks for underground services shall be made by the Contractor. Services damaged by the work shall be repaired by the Contractor.

Topsoil shall be set aside separately from other spoil and kept clean of contaminants.

Advice shall be sought from the Grounds Manager should any tree roots be uncovered larger than 30mm. Such tree roots shall not be damaged or cut without inspection, advice and approval from the Grounds Manager or his/her nominee.

Care shall be taken when using excavators or other digging or earthmoving equipment in proximity to overhanging trees or other vegetation to avoid damage to branches or the canopy.

At times in certain sensitive landscape situations, hand digging will be required. The Grounds Manager will provide further information during preliminary discussion regarding the project works.

Subsoils must not be mixed with topsoil when backfilling trenches or used as a finishing layer.

Heavy clays and rocks shall be discarded and removed from site as waste unless otherwise agreed. No contaminants of any description are to be buried or remain on site.

Stockpiled topsoil is to be reused to a minimum depth of 100mm.

Fresh soils, sands and aggregates brought to site for reinstatement must be clean and appropriate to their purpose. Additional topsoil shall be of consistent physical and chemical properties to existing, and complimentary to intended planting. Soil analysis evidencing appropriate physical and chemical properties may be required for larger quantities (greater than five cubic metres) of additional fresh topsoil. This shall be obtained by the Contractor from the supplier and submitted to the Grounds Manager for approval.

Geotextiles where used shall be new, comply with the relevant Australian Standard, be fit for purpose and installed correctly.

All reinstatement shall be adequately compacted to avoid slumping and finished grade changes over time. Heavy compaction of areas to be planted must be avoided.

Finished grades should not enable soils or mulches to erode or wash onto adjacent paths or hard surfaces, or contaminate drains, with following rain.

On completion, the site shall be cleared of all spoil and hard surfaces left clean. Any landscape fittings temporarily removed to allow the work to proceed will be reinstated by the Contractor.

Depending on the scale and location of the work regular site inspections may be required by the Grounds Manager or his/her nominee. Any non-compliance will require work to cease until satisfactory rectification can be made.

15.8 SOFT LANDSCAPING

Garden soils:

Imported garden topsoils, where required, must be free of perennial weeds and their roots, bulbs and rhizomes; building rubble and other contaminants which can adversely affect plant growth; and rocks and stones greater than 5mm or 5% by volume; of neutral pH (6.0 – 7.0); friable with a light to medium texture; free of silts and non-hydrophobic.

Imported garden soils are required to meet Australian Standard AS4419 *Soils for Landscaping and Gardening Use*.

NATA accredited laboratory soil tests for physical properties and nutrient levels may be required.

Imported soils shall be blended with existing soil by first ripping and cultivating site subsoil to a depth of 300mm then thoroughly mixing through the new soil.

Where necessary to avoid ponding of surface water in garden beds or grassed areas, subsoil drainage shall be installed using 100mm PVC AG Drain/UPVC slotted drain pipe.

Garden beds:

New garden beds shall be constructed by excavating to a minimum depth of 300mm. Existing topsoil shall be separated and kept aside. Subgrade in areas for planting shall be ripped to a minimum depth of 150mm and cultivated with gypsum. Subsoils shall then be graded and lightly and evenly compacted at 300mm below finished level. 200mm topsoil shall be added uncompacted. Retained and imported topsoils shall be blended before use. 75mm mulch shall be applied as a finish dressing.

Garden beds shall be edged to clearly define the extent of the garden bed, retain the mulch, and inhibit the encroachment of grasses and/or weeds from adjacent lawn areas. Refer Appendix 1.

Garden mulches:

All mulches must be free of weed material and seed, debris and other foreign matter or contaminants of any kind. No recycled building materials such as treated pine or chipboard are acceptable.

Organic mulches must be thoroughly aged, with a coarse texture comprising 80% of particles in the 20-35mm size range and 5-10mm in thickness, with no particles exceeding 50mm.

Organic mulches may be derived from weathered bark, chipped or shredded plantation pine or other tree prunings, or wastes from native plantation operations. Such mulches should comply with Australian Standard AS4454 *Composts, Soil Conditioners and Mulches*.

Inorganic mulches may be suitable for some applications, and comprise gravels, stone, recycled brick or coarse sands. River cobbles, stone or pebbles are acceptable in small feature landscapes only, but preference should be given to alternative materials with less environmental impact. Samples must be submitted to the Grounds Manager for approval prior to application.

Mulches shall be evenly spread at 75mm thickness over garden beds except for directly around the stems of all plants to avoid the possibility of rot. Valve boxes, drain covers or other landscape hardware or fixtures at surface level shall not be covered.

Any nitrogen drawdown, or likelihood of, resulting from the application of mulches must be counteracted by use of appropriate fertilisers

Planting:

A planting design plan shall be developed for each project, denoting the species to be used, the size and number of each species, and the set out and density within any garden bed, for approval by the Grounds Manager.

Any proposed species substitution or other changes to the design plan must be advised to the University Project Manager and the Grounds Manager for approval prior to installation.

Planting density must take full account of the mature size of all species used so that each specimen has adequate space for growth and establishment. New plants must not be crowded so as to inhibit proper growth and form, or spread so far that empty space in the garden will remain over time.

The minimum pot size for garden planting is 150mm. Introduced trees should be of advanced size. Only quality professional nursery stock is acceptable. Plants must be treated and handled carefully at all times to avoid damage to roots, stems and growing shoots.

New plants must be provided with adequate nutrition by application of appropriate fertilisers to ensure full establishment.

Plants must be set at the correct planting depth so the top of the rootball is even with the finished soil level. The planting hole, to be prepared by hand unless another methodology is approved, must be 75-100mm wider than the rootball. A suitable fertiliser shall be incorporated with topsoil for backfilling.

Plants must be thoroughly watered in by hand immediately on completion of the planting task.

Fertilisers:

Pelletised, low odour, slow release organic fertilisers with a balanced NPK ratio are preferred.

Low phosphorus fertilisers are to be used for native plantings.

Fertilisers intended for use with establishing new plantings, including lawns, are to be advised to the University Grounds Manager for approval during the project design phase or prior to use.

All fertilisers are only to be used at the manufacturer's prescribed rate.

15.9 HARD LANDSCAPING

Refer to the Appendices at the end of this Section for data sheets on hard landscaping elements.

15.10 ROOFTOP WORKS

The University's Grounds Manager must be consulted during the planning and design process for any green roof project.

The following points are to be adhered to when designing green roofs:

- Projects are only to be documented by consultants with design experience in similar installations.
- Only use waterproof membranes which are specifically designed for roof gardens
- Use a water membrane which incorporates a certified root barrier treatment or, if a separate root barrier layer is being used, the separate membrane materials must be compatible with each other

- When the membrane installation is complete, it must be tested by flooding and inspection.
- Only use plants which are proven to survive in roof top environments. Plants with aggressive root systems are not to be used.
- The growing medium is to comprise a minimum of 75 per cent inorganic materials.
- Any concrete roof is to contain a waterproofing additive.
- Particular attention is to be paid to ensure that water drains freely and does not pond.
- All the drainage and protection layers and irrigation components must relevant Australian standards.
- It is preferred that non-potable water sources for irrigation of roof gardens are explored.
- Any exposed components are to be UV stable
- Roof outlet drains are to be located, sized and protected to ensure that they never become covered or blocked

Consultants are encouraged to refer to the Growing Green Guide

<http://www.growinggreenguide.org/>

A documented photographic record through the construction period of any roof top project must be maintained by the builder. The photographic record must clearly show the built form of the garden area including hobs, irrigation, drainage points as well as drainage and protection layers.

15.11 WATER SUPPLY AND IRRIGATION

- All work is to be compliant with all applicable Plumbing Regulations and a Compliance Certificate is to be issued to the University on completion.
- The Consultant / Contractor must determine the location of any underground services in the area of the works. Repair costs to services damaged by the Contractor, shall be the responsibility of the Contractor.
- All materials and quality of work shall be to the best of their respective kind, conform to manufacturer's recommendations for installation and shall meet the following Australian Standards:

AS 1477	Unplasticised PVC (uPVC) pipes & fittings for pressure applications
AS 3879	Solvent cements and priming fluids for use with unplasticized PVC (uPVC) pipes and fittings
AS 1462	Methods for testing uPVC pipe & fittings
AS 4130	Polyethylene Metric – PE80B – pipe for pressure applications
AS 1432	Copper tubes for water, gas and sanitation
AS 2032	Code of Practice for installation of PVC pipe systems
AS 2698.1	Polyethylene micro irrigation pipe
AS 2053	Non-metallic conduits and fittings
AS 3000	Electrical installations
AS 3500.1	National Plumbing and Drainage Code: Part 1 Water Supply
- All pipework and associated fittings are to be new Class 12 uPVC, unless otherwise stated.

- Trenching for pipework will be to a depth to allow for 300mm minimum cover over installed pipe unless agreement with the nominated University project manager is reached for alternative installation. Trenches are to be backfilled with soil, free of rock or other debris, to surface level. Trenches are not to be left open overnight.
- Conduits under paving for wiring & pipework are to be 100mm sewer grade PVC, unless otherwise stated. Any lifting of paving for conduit placement will require reinstatement according to the University Design Standard for paving (refer Appendix 1).
- Solenoid control wires are to be coded, poly coated valve wiring of 0.5mm diameter between controller and all solenoid valves where wire runs are less than 100m. Allow for 500mm loop at each valve connection to provide for valve removal for servicing. All wire runs should be continuous with no joints. All wiring joints in the field must be made using 'king' type 3M DBY or heat shrink connectors
- Two spare control wires to be left at the furthest solenoid in any direction from the controller, and at the master solenoid valve to allow for possible future extension of the irrigation system, or repair.
- An external lockable power switch is to be fitted in line to the controller
- An appropriate backflow prevention device in line after the water meter or master gate valve is required unless backflow prevention is otherwise already provided on the supply line.
- Rain and/or ET sensor, or dedicated weather station to be fitted to all new systems. Soil moisture sensor(s) may be required for major systems. Any such need will be advised by the Grounds Manager during project design and consultation.
- Large multi-station systems shall have a flow control valve fitted on the downstream side of the meter or backflow device. Fitting of a flow control valve substitutes for a master gate valve. The flow control valve is to be wired back to, and compatible with, the system controller
- Irrigation systems utilising reclaimed water must use appropriately identifiable components (lilac colour)
- On completion of installation the system is to be tested, in the presence of a representative from the University's Grounds Manager.
- The Contractor will provide to the University as built drawings of the installed system and any operational manuals and keys for the controller box.
- A 12 months defects liability period for the system will apply from the commissioning date or date of practical completion, whichever is the later, during which time the Contractor will be responsible for maintenance of the system.

The following components and arrangements are approved for use in irrigation systems:

Micro/drip Systems

- Toro Drip Eze or Enviro-Drip 13mm pressure compensating
- Emitters at 30cm spacing
- When laid in grid pattern, line spacing 300mm apart in garden beds; 500mm apart under trees, unless otherwise specified.

Garden (and short-throw turf) Sprays

- $\frac{3}{4}$ " threaded PVC no-flex risers for standpipe use

- Rainbird 1800 spray bodies (pop up height to suit application) or equivalent
- Filter screens to be fitted to each spray
- Hunter MP Rotator spray heads appropriate to each application

Turf Sprays

- Hunter PGP rotors (nozzles selected according to application)

Irrigation Controllers (appropriate to given system application)

- Basic automatic controller: Hunter Pro C (modular)
- Smart automatic controller: Hunter I-Core or Hunter ACC
- Battery-operated programmable controller: Hunter Node

Sensors (Rain, ET, Flow)

- Rain sensor (basic): Hunter Rain-Clik (wired or wireless)
- Weather sensor: Hunter Solar Sync (wired or wireless)
- Flow sensor (compatible with ACC and I-Core controllers): Hunter Flow-Sync

Valves

- Gate valves to function as isolation valves, prior to the solenoid valve, are to be fitted on the discharge side of the water meter or mains supply point, and to irrigation lateral lines. Gate valves must be tested, brass construction, with a rated working pressure of 800 kPa, and 25mm BSP threaded female connection.
- Solenoid valves are to be 25mm Irritrol (Richdel) 205 series with flow control, or equivalent
- A Richdel master solenoid valve in line after the backflow prevention device (where fitted) or isolating gate valve, is to be installed.
- All control valves are to be placed below ground and housed in suitably sized commercial grade valve boxes. Valve boxes are to be set flush at finish level in lawn areas and 50mm above finished grade in garden beds.

Irrigation system performance

- Spray irrigated areas are required to meet industry best practice for effectiveness of application and uniformity. The industry standard for sprinklers is Field Distribution Uniformity (DU) 75%
- Drip systems are required to achieve high uniformity of emitter discharge. Emission Uniformity (EU) 85% is required.
- Applied water is not to result in runoff or wasteful application.
- The selection of components is required to achieve effective and reliable operation and sound functioning of the irrigation system.
- All equipment selected and installed is to meet local regulatory requirements and Australian Standards.
- All spray fittings to be installed to throw water away from building walls

15.12 DRAINAGE

Refer to Appendix 2 at the end of this Section for data sheets on drainage elements.

15.13 LIGHTING

Refer to Section 7, Electrical Services for external lighting requirements.

15.14 LANDSCAPE FURNITURE

Refer to Appendix 3 at the end of this Section for data sheets on landscape furniture.

15.15 DEFECTS LIABILITY PERIOD

During the defects liability period the Contractor will be responsible for the full establishment and maintenance of installed landscape plantings, paving, fittings and features, and the operation and proper functioning of associated irrigation.

On completion of the defects liability period:

- Any planting failures, equipment breakdowns or other repairs associated with installations delivered as part of the project works is to be made good by the Contractor.
- Trees and garden plantings shall be healthy and well presented.
- The density and composition of the planting shall comply with the specification.
- Garden beds shall be free of weeds and have an appropriate covering and depth of mulch or other specified surface dressing.
- All landscape surfaces, fixtures, fittings, furniture and equipment shall be in proper order as per the specification.
- An inspection carried out by the Grounds Manager or his/her nominee and approval given.

General cleaning of external areas within the project precinct during the Defects Liability Period will be the responsibility of the University.

15.16 DESIGN CHANGE AUTHORISATION

All requests for changes to the requirements of the Design Standards must be made on the Modification Request Form. No design work is to proceed on the basis of the proposed modification until the modification request has been approved in writing.

15.17 AS-BUILTS, WARRANTIES AND MANUALS

In addition to the normal items required to be provided to a building owner at project completion, all requirements noted in this section of the Design Standards are to be provided to the University's Project Manager. Draft documentation is required four weeks prior to practical completion and final documentation no later than four weeks after practical completion.

15.18 APPENDICES

- Appendix 1 - Hard Landscaping
- Appendix 2 – Drainage
- Appendix 3 – Furniture

Note that the information in the above appendices generally applies to all campuses however some adjustments may be appropriate for the non-Parkville campuses. Any such changes are to be approved via the Modification Request Form noted in Section 15.16 above.

APPENDIX 1 – Hard Landscaping

This Appendix comprises the following data sheets:

- Brick Paving - Pedestrian Footpaths
- Brick Paving – Vehicle Roads
- Bluestone Pavers - Pedestrian Footpaths
- Bluestone Pavers – Vehicle Roads
- Tactile Indicators
- Handrails
- Fences
- Edges – Paved Brick
- Edges – Steel Strip
- Edges – Bluestone

Paving Element –Brick Paving for Pedestrian Footpaths

Description

University Grey brick paving is one of the two standard materials used for pedestrian paving treatment at the University of Melbourne. The pavers used are Austral University Grey and their dimensions are approx. 230 x 110x 76mm. The arrangement of pavers for pedestrian access only areas is detailed below.



Technical Details

Pedestrian Pathways

Base Course

Thickness of pedestrian footpath base course depth is 150mm with a rating of 20mm class 2 wet mix crushed rock compacted to Aust. Standards **OR** a minimum depth of 100mm concrete slab with a minimum rating of 32mpa with SL82 steel and with a 80mm depth of 20mm class 2 wet mix crushed rock compacted to Aust. Standards

Bedding Course (Wet Mortar)

The bedding material is washed coarse sand from Aggregate Sand Seymour 921055 mixed six parts with one part Portland cement. The wet consistency should be firm and hold together when squeezed in the hand.

Bedding should not exceed 50mm depth and not less than 25mm depth. The mortar must not dry out whilst laying is in progress.

Brick Paving

Bricks are laid normally in stretcher bond pattern. Bricks must be laid to levels and lines as per drawing supplied but should always have a minimum fall of 1:80 to allow for adequate drainage.

Large colour or size variation between deliveries from the brick supplier are not acceptable. Colour blending, to avoid patches of light and dark colours can be resolved by working off three paver pellets at the same time, is the responsibility of the layer. Using a rubber mallet the bricks should be hand-tapped down into the mortar, with a gap of approximately 3mm between courses and verticals. No mechanical vibrators are to be used. The final surface profile shall be without hollows that would allow water to pond.

Joint Filling

After each section of the area is completed fine white dry washed sand must be brushed into the spaces between the bricks and some sand allowed to remain on the surface. The latter must be swept off when the works are completed and joints completely filled.

Paving Element – Brick Paving for Vehicle Roads

Description

University Grey brick paving is one of the two standard materials used for road access treatment at the University of Melbourne. The pavers used are Austral Brick – University Grey and their dimensions are approx. 230 x 110 x 76mm. The arrangement of pavers for roads or shared (pedestrian and vehicular) access are detailed below.

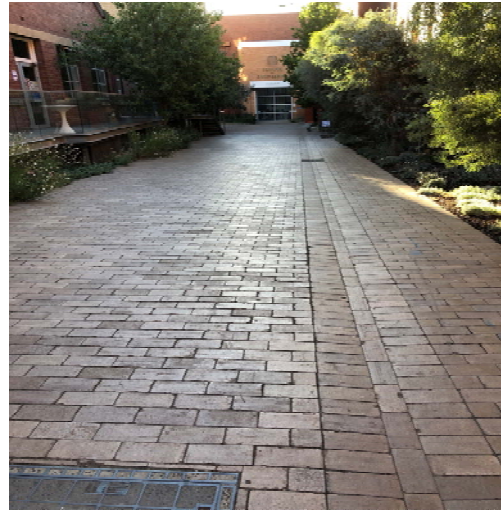

Technical Details

Vehicle Roads

Base Course

Thickness of road base course is 300 mm thick of 20mm crushed rock compacted to Aust. Standards or no less than 150mm concrete slab minimum 25 mpa with SL62 steel with a sub base of 80mm of 20mm crushed rock compacted to Aust. Standards.

Bedding Course (Wet Mortar)

The bedding material is washed coarse sand from Aggregate Sand Seymour 921055 mixed six parts with one part Portland cement. The wet consistency should be firm and hold together when squeezed in the hand. Bedding should not exceed 50mm depth and not less than 25mm depth. The mortar must not dry out whilst laying is in progress.

Brick Paving

Bricks are laid normally in stretcher bond pattern. Bricks must be laid to levels and lines as per drawing supplied but should always have a minimum fall of 1:80 to allow for adequate drainage. Large colour or size variation between deliveries from the brick supplier are not acceptable. Colour blending, to avoid patches of light and dark colours can be resolved by working off three paver pellets at the same time, is the responsibility of the layer. Using a rubber mallet the bricks should be hand-tapped down into the mortar, with a gap of approximately 3mm between courses and verticals. No mechanical vibrators are to be used. The final surface profile shall be without hollows that would allow water to pond.

Joint Filling

After each section of the area is completed fine white dry washed sand must be brushed into the spaces between the bricks and some sand allowed to remain on the surface. The latter must be swept off when the works are completed and joints completely filled.

Paving Element – In-situ Bricks Paving Roads & Footpaths

Technical Details

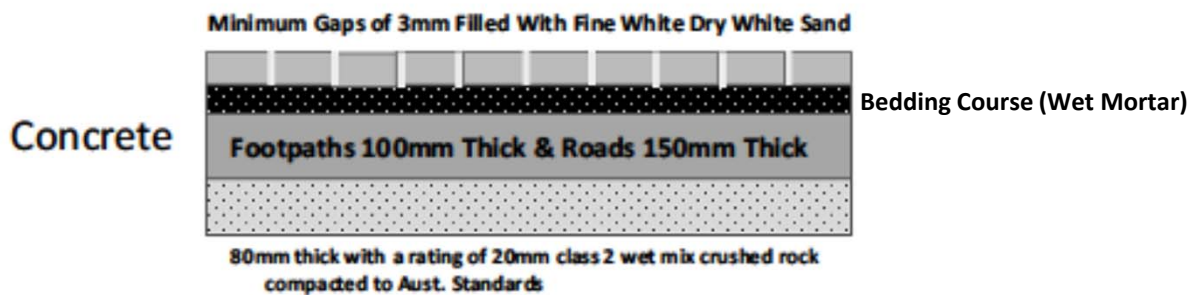
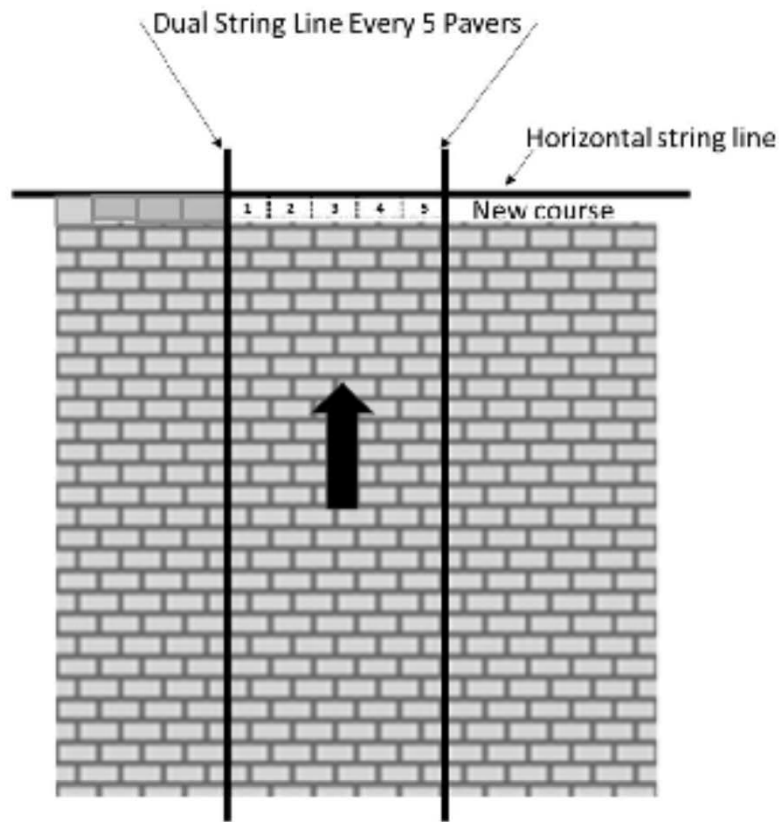

OR

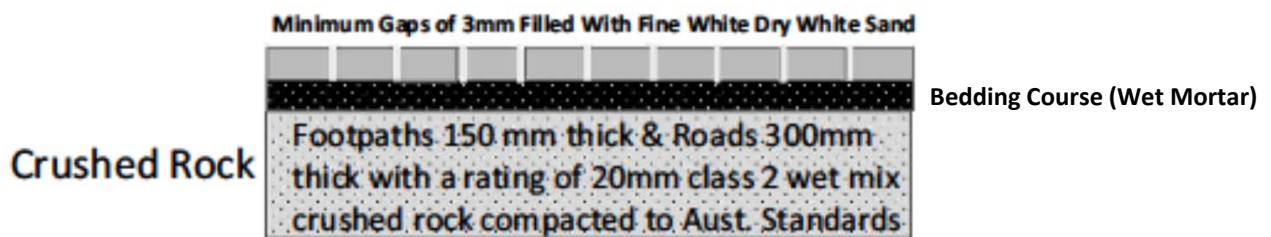

Paving Element – Bluestone Pavers

Bluestone Pavers For Roads

Description

Bluestone pavers are one of the two standard materials used for vehicle access treatment at the University of Melbourne.

The bluestone paver dimensions are of various lengths and widths with a minimum depth of 80mm.

The type of bluestone used is diamond sawn with an approved sandblasted finish. The arrangement of pavers for roads and for shared (pedestrian and vehicular) access are detailed below.

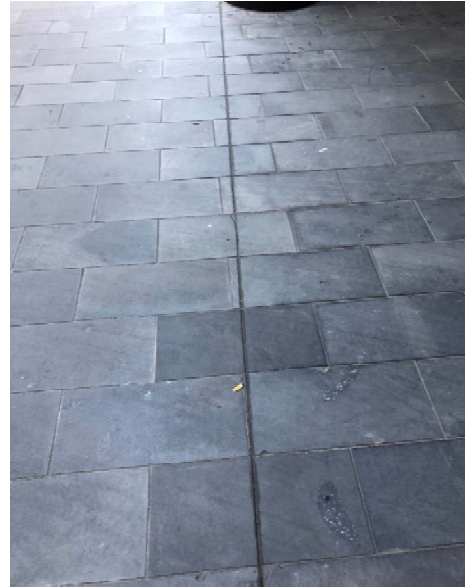

Technical Details

Vehicle Road Ways

Sub Base Course

Thickness of the sub base for roadways is at a minimum depth of 80mm with a rating of 20mm class 2 wet mix crushed rock compacted to Aust. Standards

Base Course

Thickness of the base concrete slab for roadways is at a minimum depth of 200mm with a minimum rating of 32 mpa with SL82 steel.

Bedding Course (Wet Mortar)

The bedding material is washed coarse sand from Aggregate Sand Seymour 921055 mixed six parts with one part Portland cement. The wet consistency should be firm and hold together when squeezed in the hand. Bedding should not exceed 50mm depth and not be less than 25mm depth. The mortar must not dry out whilst laying is in progress.

Bluestone Paving

Pavers shall be 80mm thick (nominal) diamond sawn bluestone with an approved sandblasted finish. no more than 20% "cats paws" (blotches) and/or vented streaks on the face of the pavers is permissible.

Grouts/Joints

Grouts/Joints between pavers shall be a maximum 2.5mm wide. Grout joints with an approved non shrink cementitious grout (Lanko 702 Durabed or equivalent which is equal and approved). Mix and apply in accordance with manufacturer's recommendations. Ensure that no residue grout remains on paver surface.

Max 2.5mm Grout Joint

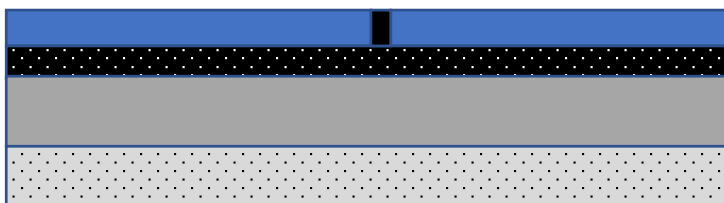

Min. Width 80mm Bluestone Paver

Min. 25 to 50mm Depth Bedding Course

Min. depth 200mm Concrete Slab

Min. depth 80mm - 20mm class 2 wet mix crushed rock compacted

Paving Element – Bluestone

In-situ Bluestone Pavers For Pedestrian Footpaths

Description

Bluestone pavers are one of two standard materials used for pedestrian footpaths at the University of Melbourne.

The bluestone paving dimensions are of various lengths, widths with a minimum thickness of 40mm.

The type of bluestone used is a diamond sawn with an approved sandblasted finish. The arrangement of pavers for pedestrian footpaths is detailed below.



Technical Details

Pedestrian Footpaths

Sub Base Course

Thickness of the sub base for footpaths is at a minimum depth of 80mm with a rating of 20mm class 2 wet mix crushed rock compacted to Aust. Standards.

Base Course

Thickness of the concrete slab base for footpaths is at a minimum depth of 100mm with a minimum rating of 32 mpa with SL82 steel.

Bedding Course (Wet Mortar)

The bedding material is washed coarse sand from Aggregate Sand Seymour 921055 mixed six parts with one part Portland cement. The wet consistency should be firm and hold together when squeezed in the hand. Bedding should not exceed 50mm depth and not be less than 25mm depth. The mortar must not dry out whilst laying is in progress.

Bluestone Paving

Pavers shall be 40mm thick (nominal) diamond sawn bluestone with an approved sandblasted finish.

No more than 20% "cats paws" (blotches) and/or vented streaks on the face of the pavers is permissible.

Grouts/Joints

Grouts/Joints between pavers shall be a maximum 2.5mm wide. Grout joints with an approved non shrink cementitious grout (Durabed or equivalent which is equal and approved). Mix and apply in accordance with manufacturer's recommendations. Ensure that no residue grout remains on paver surface.

Max 2.5mm Grout Joint

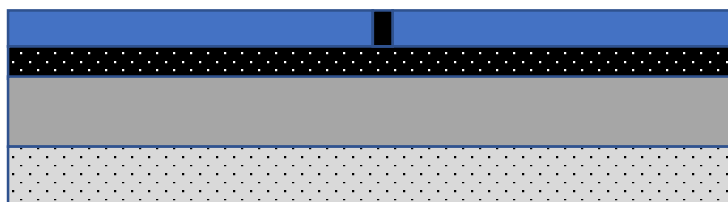

Min. Width 40mm Bluestone Paver
Min. 25 to 50mm Depth Bedding Course
Min. depth 100mm Concrete Slab
Min. depth 80mm - 20mm class 2 wet mix crushed rock compacted

Tactile Indicators

Bluestone tactile Pavers For Pedestrian Footpaths

Description

Bluestone tiles with granite tactile indicators are a standard material used in the University.

They are used to assist visually impaired pedestrians in hazardous areas and for directional access treatment.

The tactile tile comes in multiple dimensions sizes 300sq, 400sq and 600sq and is 40mm thick.

The tactile tile must be installed compliant with DDA Standards.



Technical Detail:

Pedestrian Footpaths

Sub Base Course

Thickness of the sub base for footpaths is at a minimum depth of 80mm with a rating of 20mm class 2 wet mix crushed rock compacted to Aust. Standards.

Base Course

Thickness of the concrete slab base for footpaths is at a minimum depth of 100mm with a minimum rating of 32 mpa with SL82 steel.

Bedding Course (Wet Mortar)

The bedding material is washed coarse sand from Aggregate Sand Seymour 921055 mixed six parts with one part Portland cement. The wet consistency should be firm and hold together when squeezed in the hand. Bedding should not exceed 50mm depth and not be less than 25mm depth. The mortar must not dry out whilst laying is in progress.

Bluestone Paving

Pavers shall be 40mm thick (nominal) diamond sawn bluestone with an approved sandblasted finish.

No more than 20% "cats paws" (blotches) and/or vented streaks on the face of the pavers is permissible.

Grouts/Joints

Grouts/Joints between pavers shall be a maximum 2.5mm wide. Grout joints with an approved non shrink cementitious grout (Durabed or equivalent which is equal and approved). Mix and apply in accordance with manufacturer's recommendations. Ensure that no residue grout remains on paver surface.

Handrails

The University preferred external type of handrail is stainless steel or galvanized steel and must be compliant with DDA Standards.

All external handrails must have skateboard deterrent components and a button on either end of the hand rail to assist the visually impaired as per drawing below. The end of the handrail must be finished with a curved end or end post as per drawing and photo.



Technical Details

All handrail components, dimensions and installations must be compliant with DDA standards.

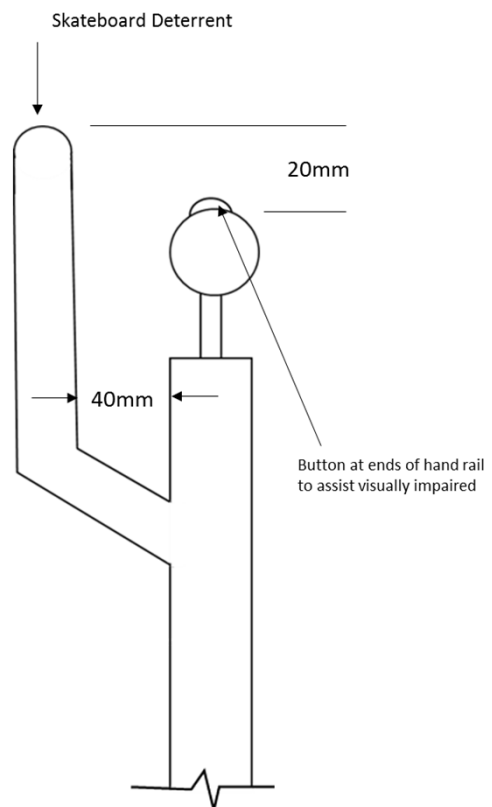
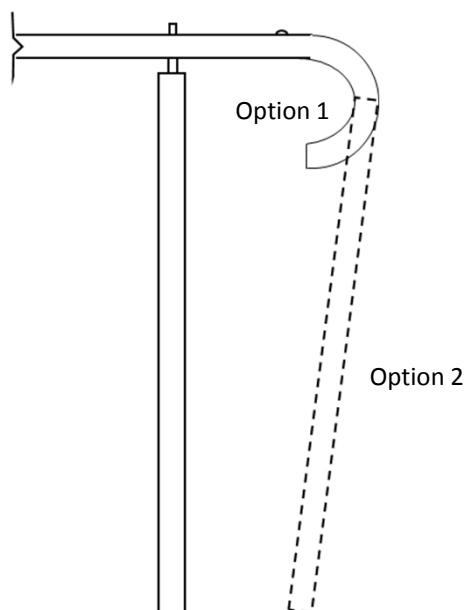

Fences

Description:

University border fencing.

A



B



Technical Details

The University has two preferred fences.

Top Rail (Tube)	50x25x3mm	Top Rail D Section	50x6mm
Posts (Tube)	40x40x3mm	Posts (Tube)	75x75x3mm
Pickets / Baluster (Round)	12mm ϕ	Pickets / Baluster	40x5mm
Bottom Rail	40x12x3mm	Bottom Rail	75x50x3mm

Fence (**A & B**) components either galvanized steel or hot dip galvanized.

Fence (**A & B**) Pickets / Balusters maximum spacing is 115 mm.

Fence posts must have a minimum depth of 300 mm into a concrete footing.

Maximum span between post 1300 mm.

Concrete footings 300x300x450 depending on soil condition .

University preferred colour and paint type is : Dulux 'PG1A7 TICKING' - Super Enamel High Gloss

Edges

Paved Brick Garden Edges



Product Description

Garden edges are used in instances where garden beds are adjacent to University Grey brick pedestrian paving. Pavers adjacent to mulch are to be laid in a repetitive, offset fashion with a concrete haunch on the end of the paver to prevent movement. This arrangement also applies with bluestone paving.

Installation

Garden edges are to be installed in all instances where university grey paving or bluestone paving and garden beds are adjacent.

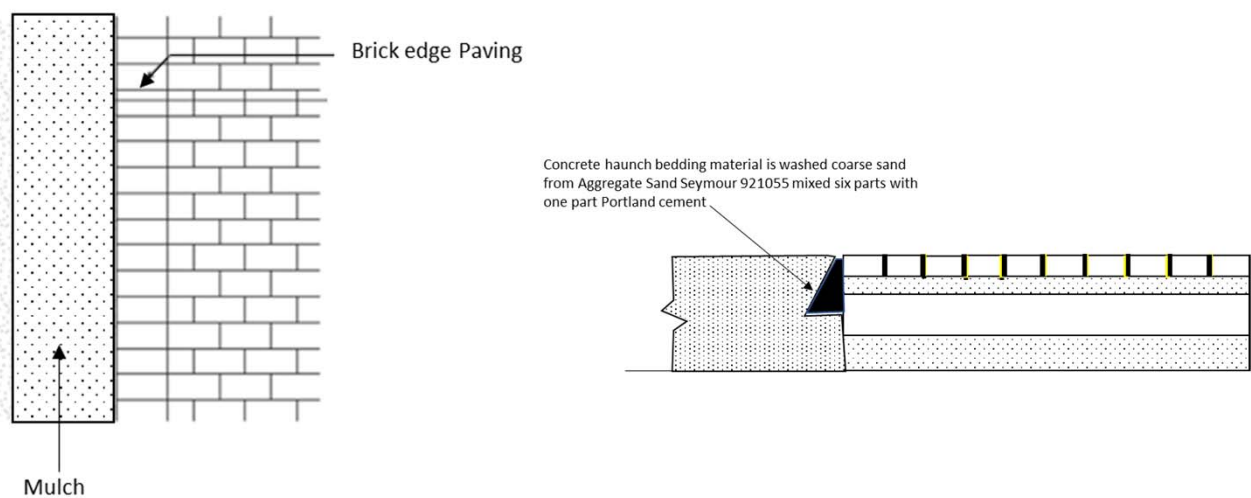

Edges

Steel Garden Edges



Product Description

Mild steel or stainless steel edges are used for separating paved or asphalted paths from garden beds and lawn. These edges are to be used where separation for tight or curved areas is required.

Installation

When a hard course of bricks cannot be laid e.g. around trees, then steel edges are to be installed flush with paving finished level.

The minimum dimension of mulch area for trees is governed by the drip line of the tree foliage.

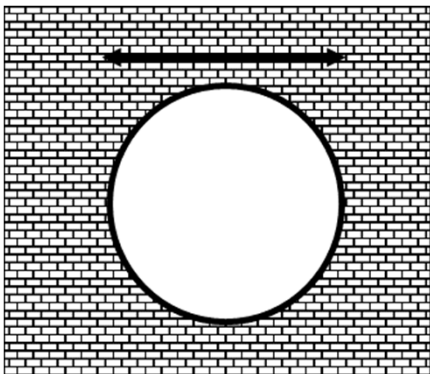

Concrete haunch bedding material is washed coarse sand from Aggregate Sand Seymour 921055 mixed six parts with one part Portland cement

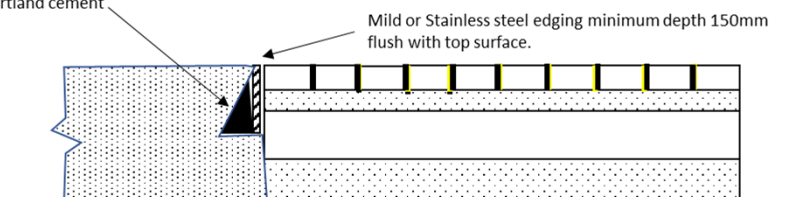

Edges

Paved Bluestone Garden Edges



Product Description

Garden edges are used in instances where garden beds are adjacent to University Grey brick pedestrian paving. Pavers adjacent to mulch areas are laid in a repetitive, offset fashion with a concrete haunch on the end of the paver to prevent movement. This also applies with bluestone paving.

Installation

Garden edges are to be installed in all instances where University Grey paving or bluestone paving and garden beds are adjacent.

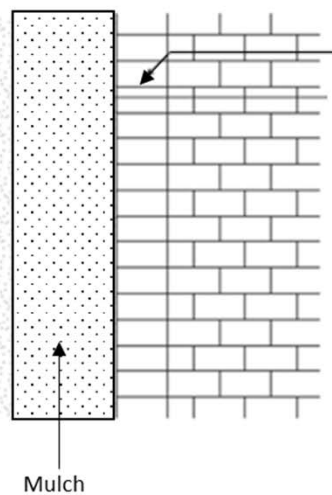

Bluestone Edging

Concrete haunch bedding material is washed coarse sand from Aggregate Sand Seymour 921055 mixed six parts with one part Portland cement

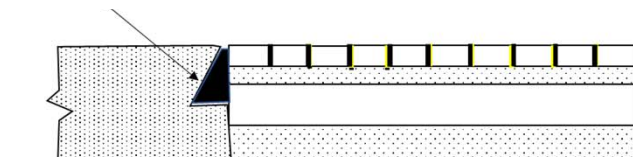

APPENDIX 2– Drainage

This Appendix comprises the following data sheets:

- Bluestone Kerb and Channel
- Brick Channel Drains
- Side Entry Pits
- Stainless Steel Grates
- Galvanised Grates
- Pits and Lids

Kerbs

Bluestone Pitcher Kerb and Channel

Product Description

Sawn bluestone kerbs are one of the two standard kerbing materials used at the University.



Technical Details

Sawn bluestone kerbstones are 300 x 300mm with a 25mm bullnose. Their length is typically 1000mm and a minimum of 800mm. Adjacent channel (gutter stone) is typically 250mm wide by 100mm thick, with a typical length of 900mm.

The bedding sub base for the bluestone kerbing is a bed of 80mm thick 20mm class 2 wet mix crushed rock compacted to Aust. Standards and a 100mm slump concrete bedding.

The butt joints in the kerb and channel must be staggered and the butt joints in the kerb sections need to be tight (no mortar).

A typical 10mm joint between the curb and channel is mortared. Refer to drawings below

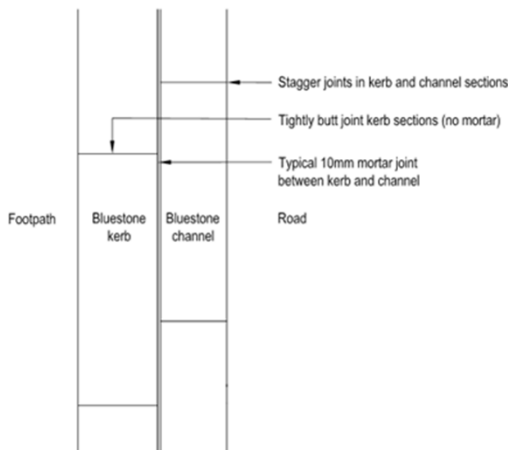

Plan

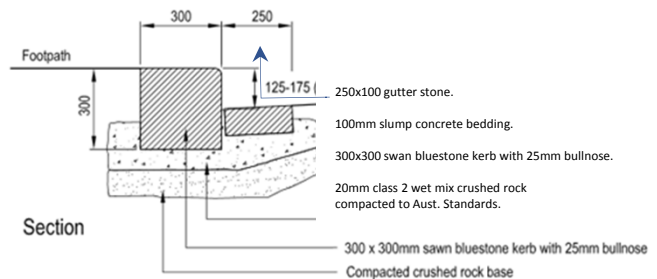

University Grey Brick Channel Drains



Description

University Grey paver spoon channels provide natural drainage in paved areas. It is the preferred detail within the University of Melbourne

Technical Details

Base Course

Refer to paving details for ether footpath or roads.

Bedding Course (Wet Mortar)

Refer to paving details for ether footpath or roads.

Brick Paving

Bricks must be laid to achieve a 10 to 15mm hollow at the deepest point in the channel to allow for adequate drainage.

Using a rubber mallet the bricks should be hand-tapped down into the mortar, with a gap of approximately 3mm between courses and verticals.

No mechanical vibrators are to be used. The final surface profile shall be without hollows that would allow water to pond.

Joint Filling

After each section of the channel is completed apply wet mortar into the joint spaces between the bricks within the channel until completely filled.

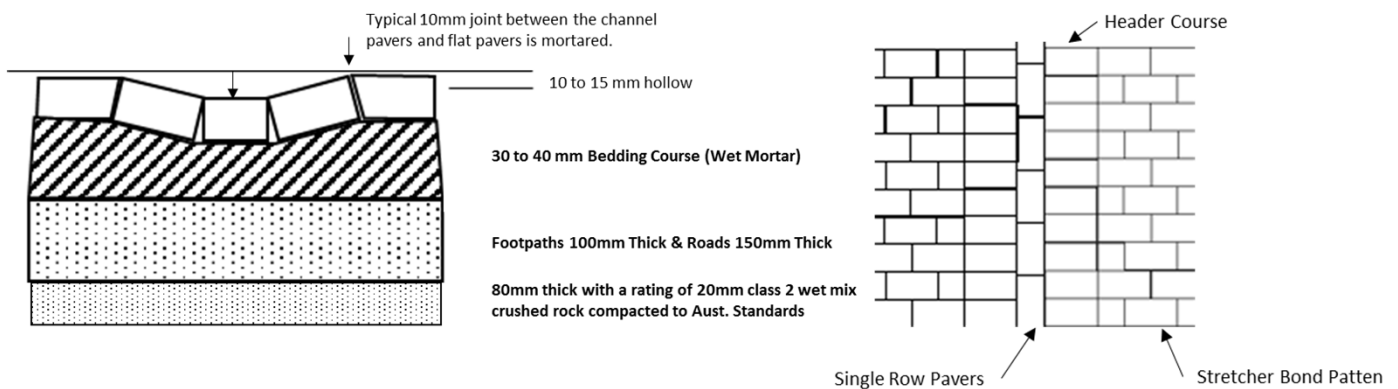

Road Drainage Pit Side Entry

Product Description

Sawn bluestone overflow kerbs with a Class D bike proof steel grate is one of the two standard arrangements used in the University.

Depending on surrounding surfaces, a concrete side entry pit may be used.



Technical Details

The sawn bluestone overflow kerb is 300 square with a 25mm bullnose. Length is typically 1300 mm to suit a standard grate.

Adjacent channel (gutter stone) is typically 250mm wide by 100mm thick, with a typical length of 900mm.

The bedding sub base for the bluestone kerbing is a bed of 80mm thick 20mm class 2 wet mix crushed rock compacted to Aust. Standards and a 100mm slump concrete bedding.

The butt joints in the kerb and channel must be staggered and the butt joints in the kerb sections need to be tight (no mortar).

A typical 10mm joint between the curb and channel is mortared.

The pit depth, pipe entry and drain details are to be designed according to site conditions.

The grate should be Class D rating (heavy duty) with a bike proof grate design.

Refer to drawings below

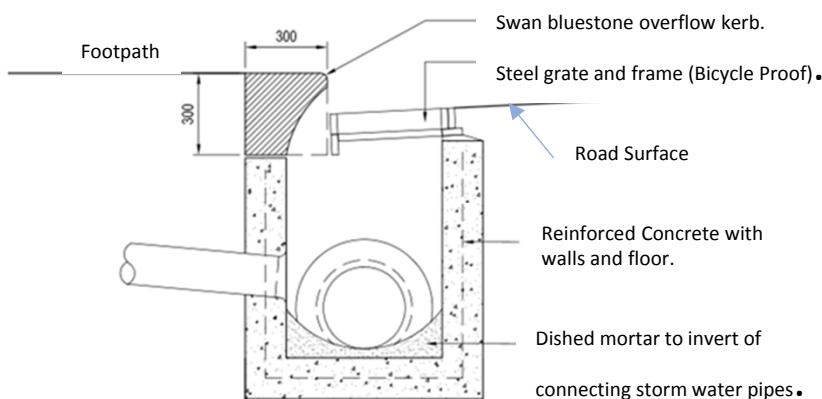

Section

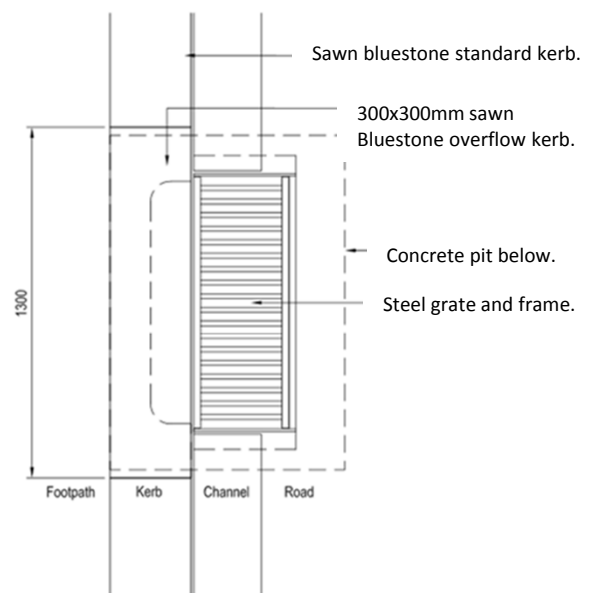

Plan

Stormwater and Strip Drain Grates / Pits

Stainless steel

Stainless steel heelguard grate pit covers are one of two preferred types of pit cover used in University grounds. The pit covers must have minimum strength rating of class D for all roads, pathways and other areas. The minimum requirement for precast concrete pits is class D and for in-situ pits the concrete must be 40 mpa with reinforcement steel.



Technical Details

Grates

Stainless steel grates should be class D rating (heavy duty) with 5mm maximum gaps between slats for every heel proof grate design. Stainless steel grates must have dimples on face surface as per drawing below.

Pits

Refer to Pits and Lids details sheet.

Stainless Steel Heel Proof Grate

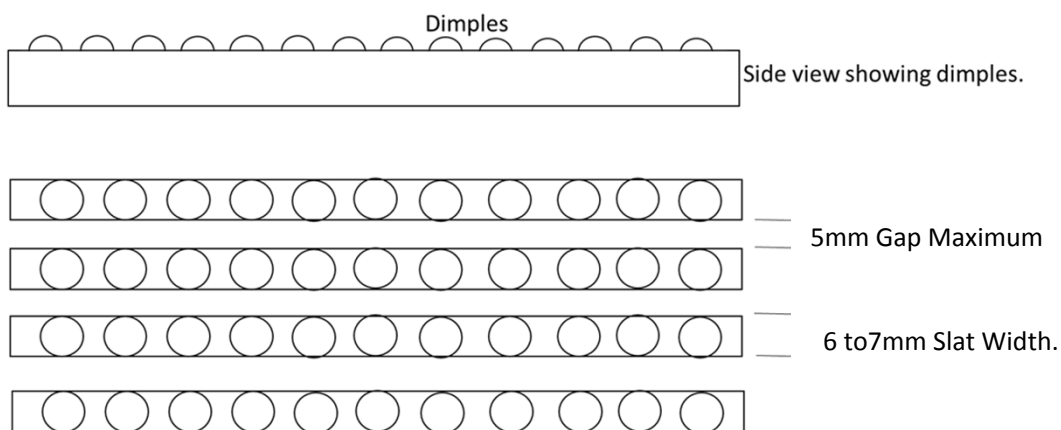

Note: Pits & Grates must be rated class D

Stormwater and Strip Drain Grates / Pits

Galvanized Steel

Galvanized steel heelguard grate pit covers are one of two preferred types of pit cover in the University grounds. The pit covers must have minimum strength rating of class D for all roads, pathways and other areas. The minimum requirement for precast concrete pits is class D and for the in - situ pits the concrete must be 40 mpa with reinforcement steel.



Technical Details

Grates

Galvanized steel grates shall be Class D rating (heavy duty) with 5mm maximum gaps between slats for heel proof grate design.

Pits

Refer to Pits and Lids details sheet.

Pits and Lids

Concrete infilled access pit covers are the preferred type of pit cover in the University grounds. The pit covers must have minimum strength rating of class D for all roads and pathways. The concrete infilled access cover is to be used for all under ground services pits.

The preferred minimum requirement for precast concrete pits is class D and for in-situ pits the concrete must be 40 mpa with reinforcement steel.



Precast pits Class D

The pre cast pit to be installed to manufacturer guidelines.

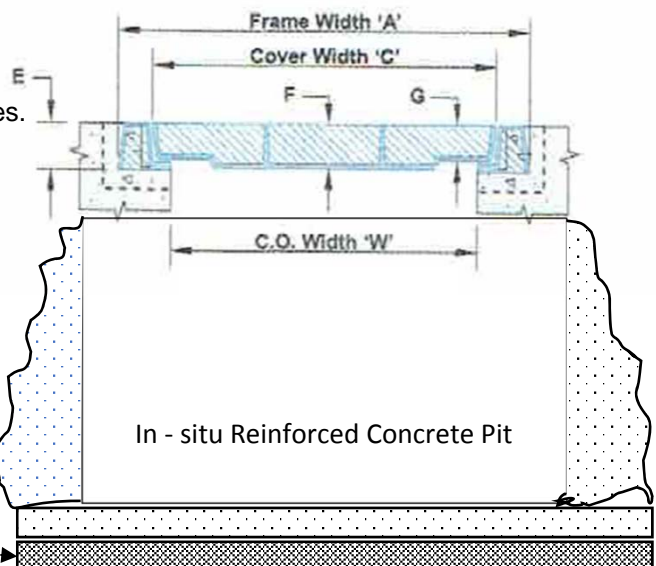
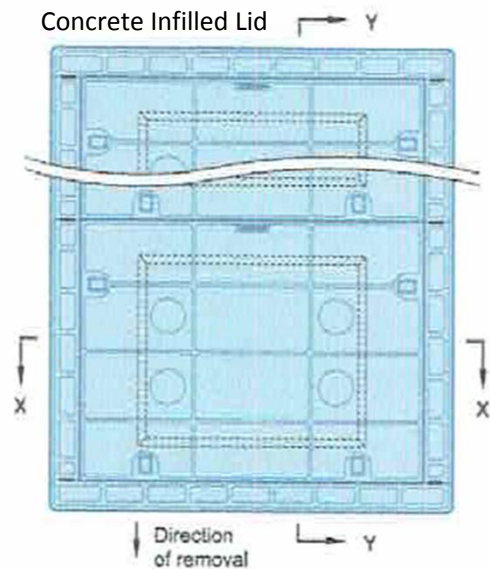

Reinforced Concrete

80mm thick with a rating of 20mm class 2 wet mix crushed rock compacted to Aust. Standards

APPENDIX 3 – Furniture

This Appendix comprises the following data sheets:

- University Timber and Concrete Bench/Seat
- York Timber Seats
- Metro Town and Park Seats
- External Bin Enclosures
- Bike Hoops
- Service Meter Enclosures

Seating

Timber Bench /Seat on concrete legs

Description

Timber and concrete Bench/Seat units are one of the standard types of seating used throughout the University.

The seat is made of Spotted Gum with galvanised mild steel brackets bolted onto concrete columns. Note - This type of seating comes with or without back rests.



Technical Detail:

Base frame is hot dip galvanised steel 100x10mm.

Timber battens are kiln dried Spotted Gum hardwood sized 132x40mm.

The concrete columns are 300mm diameter

4x M10 Dynabolt at 100mm are used to fix the seat to the concrete columns.

Installation:

Seats must be made level and 455 mm above natural surface level.

Sub-surface mounts are preferable.

Wooden seat to be bolted down to concrete column.

Concrete columns installed by contractors on site.

Finish

Timber Slats – 3 coats of Sikkens Cetol HLSe

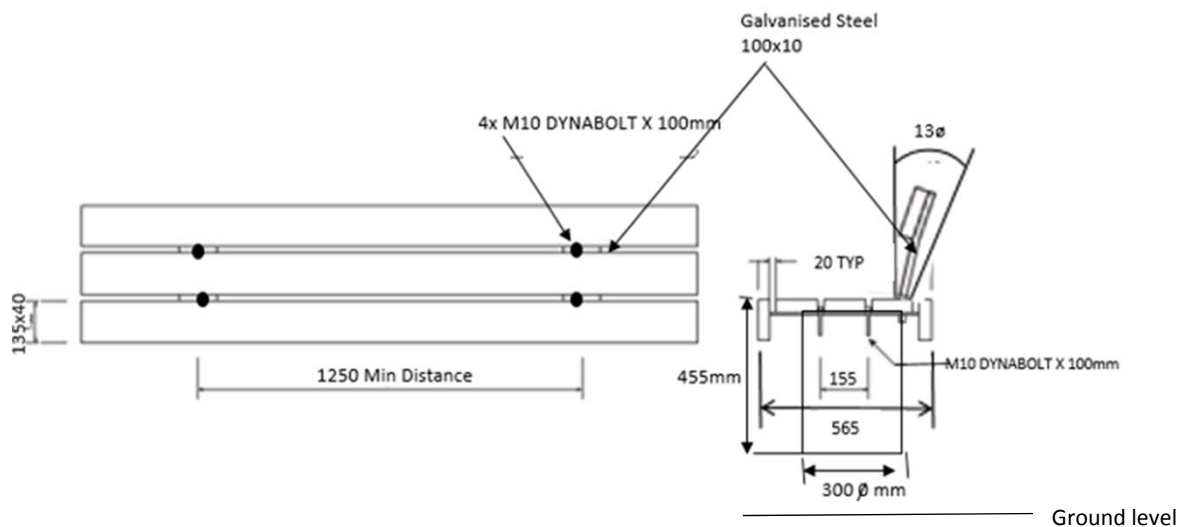

Seating

York – Seat with back

Product Description:

The 'York' Seat with back is used throughout the University in heritage areas .

The York seat is made of teak hardwood.



Installation:

When the seat is installed in outdoor paving, concrete or asphalt areas the seat must be secured with the manufacturer's anti-theft kit on a 600 x 300mm x 450mm deep concrete footings as per drawings below. It is preferred that the seats are not sited on grass areas.

Supplier:

Lister Teak Garden Furniture

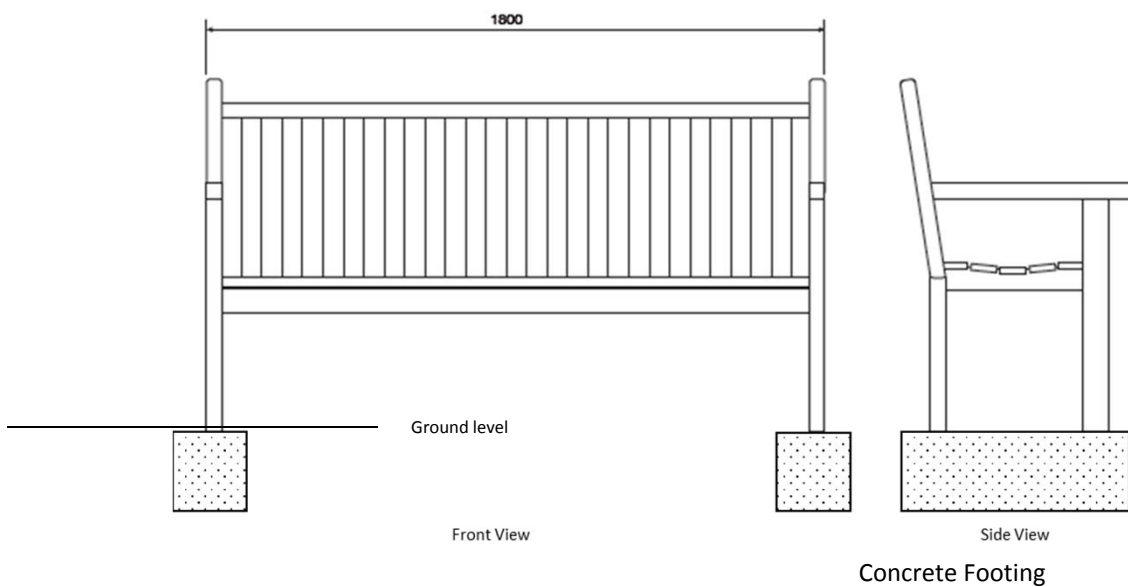

Seating

Metro - Town & Park BSE Seat

Product Description:

The timber and steel 'Metro' seat comes with or without a back rest is a marine grade aluminium unit with stainless steel fixing and its design allows up to 4 metres of continuous FSC 100% hardwood. This seat is one of three types of Metro seat used in the University.



Technical Detail:

The Metro seats to be bolted down by 4 x 10M Dynabolts x200mm.

Installation:

There are many different types of Metro seats but they are all installed the same way as per drawings. Metro seating SSD/SS - If Installed in paving areas and in asphalt areas must be bolted down on 300 X 700 X 450mm deep concrete footing, as per drawings below.

Supplier:

Stoddart Town & Park.

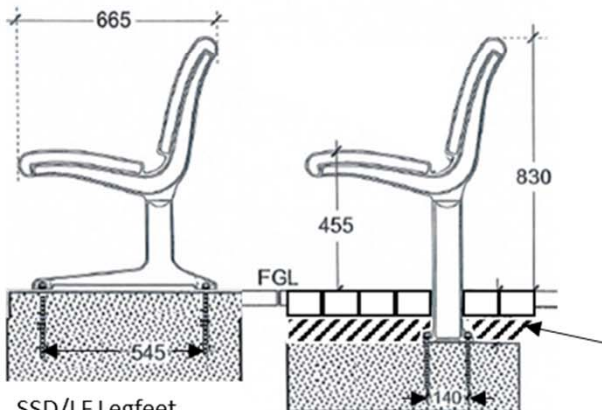

SSD/LF Legfeet (bolt down). For established concrete areas.

SSD/SS Sub-surface post. For paved and asphalt areas.

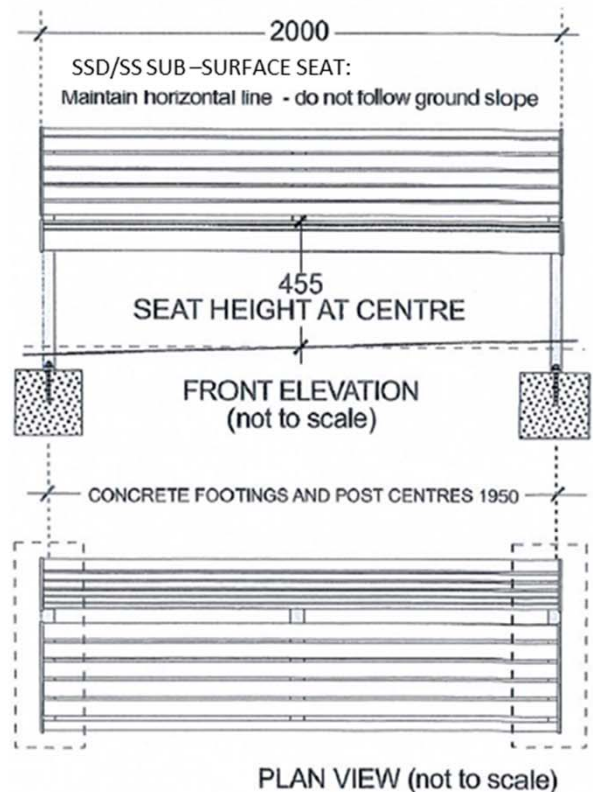

Pavers shown on mortar bed over concrete footing.

External Bin Enclosures

Litter & Recycling Receptacle Bins

Description

Metro bins are a standard stainless steel bin enclosure used throughout the university. They are installed as sets of two bins. One being red for litter and the other being yellow for recycling. The bins must have University approved signage affixed..

There are two standards for installing the bins:

1. Concrete areas
2. Paved areas



Technical Detail:

The Metro stainless steel bins are designed to encase a 110 litre wheelie bin.

Installation:

The bins are only to be installed on hard surfaces ie. concrete surface or bluestone pavers. For both options, bins are to be secured with 4 x 12M Dynabolts x 150mm.

When installing bins on bluestone pavers, the pavers must be installed as per drawing below.

Signs to be installed on both sides of stand-alone bins ie. on the door and on the back of the bin. For one sided access bins, signage is only fixed to the door.

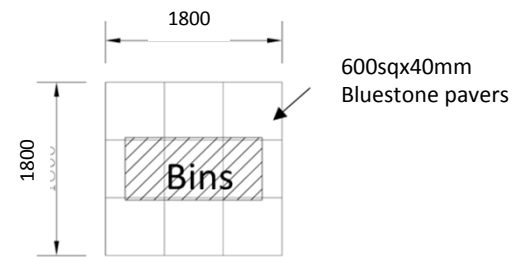

Option A
For stand alone bins access on both sides.

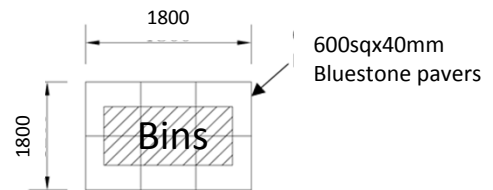

Option B
For bins up against walls fences, etc.

Supplier:

Furphy Foundry (Metro Litter Receptacle GOV119)

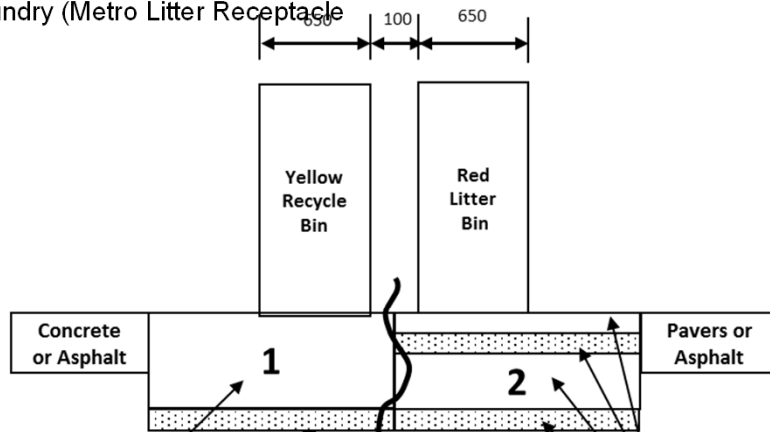

100mm Concrete Slab with a minimum rating of 32 mpa with SL82 steel.

Bluestone pavers 40mm Wide.
Min. 25 to 50mm Depth Bedding Course.
100mm Concrete Slab with a minimum rating of 32 mpa with SL82 steel.
Min. depth 80mm - 20mm class 2 wet mix crushed rock compacted

1/concrete surface or 2/ bluestone pavers

Bike Hoops

Individual Hoops Bluestone Edge

Description:

The individual bike hoops are 40NB 48.26x2.77 grade 304 linished stainless steel pipe with a 304 grade stainless steel base plate (65x200x20mm) fillet welded to the hoop. Base plates to have 20mm bolt holes.



Technical Detail:

The stainless steel bike hoops are to be bolted down with 4 x 12M Dynabolts x100mm.

Installation:

1. Bike hoops in brick paved areas must be bolted down on a concrete slab 100mm thick with a minimum rating of 32 mpa with SL82 steel . Note concrete base is the same size as the whole bike parking paved area
2. Bike hoops installed in asphalt areas are to be bolted down on 300mm square by 450mm deep concrete pads. As per Drawing below.

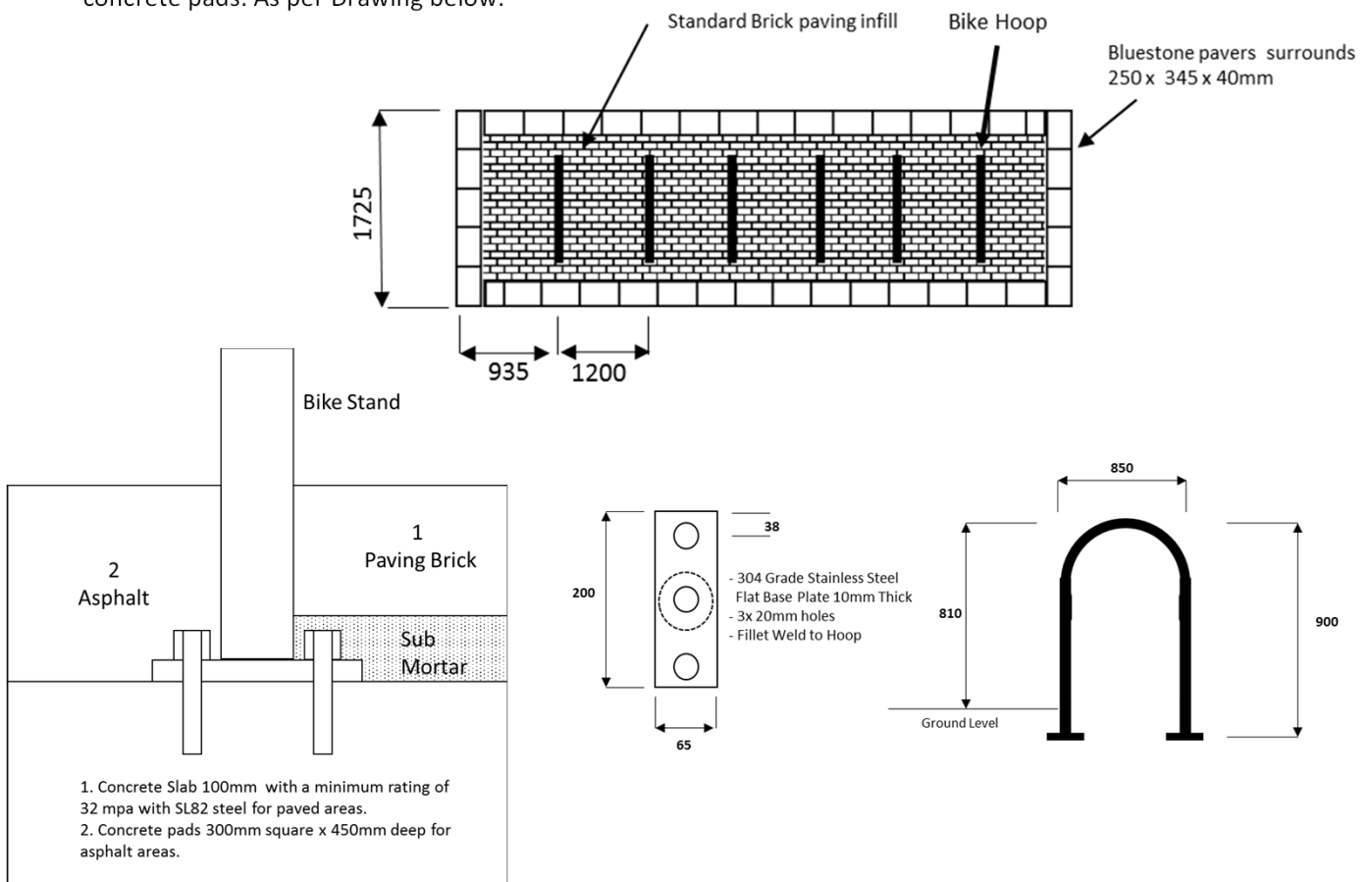

Service Meter Enclosures

Service meter enclosures are the required for all services meters and fire equipment.

Doors must open outwards and be lockable by a padlock. Type of padlock is determined by the services enclosed e.g. gas, water and fire services.

The cage must be secured down on a 75mm concrete slab.



Technical Details

Gates & enclosure framing is 50x50x3mm steel angle.
Internal 9mm perforated galvanized steel sheeting 2mm thick.
Gates & enclosure middle internal bracing railing is 25x25x3mm square tubing.
Padlock plates – 50x75x3mm flat bar with 15mm \varnothing diameter hole for padlock.
Mounting by 10mm dyna bolts galvanized.
Ball pin lift off welded gate hinges galvanized.
Centre post for double gate units is 50x50x3mm.
ALL components must be either DuraGal or hot dip galvanized steel.

University preferred colour and paint type is: Dulux 'PG1A7 TICKING' - Super Enamel High Gloss.

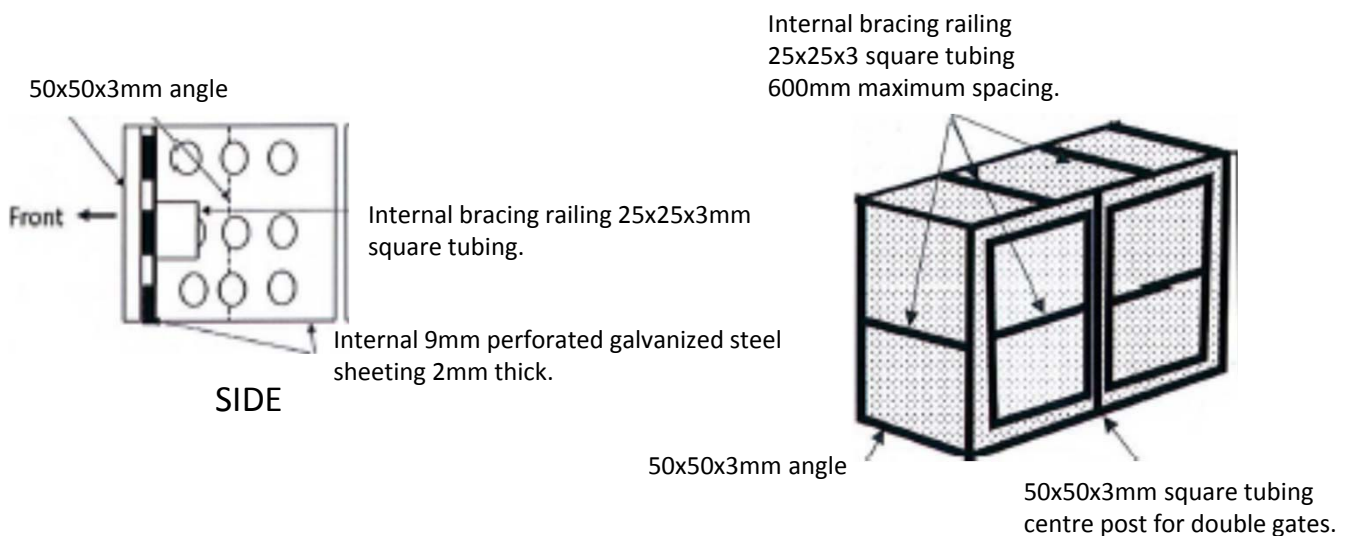

Sled Bike Hoops

4 x Galvanized bike hoops attached to galvanized steel sleds.

Description:

Galvanized bike sleds can accommodate 8 parked bikes per unit.



Technical Detail:

The bike sled hoops are to be bolted down by 4 x 16M Dynabolts x100mm or screw bolts 16Mx100mm.

Installation:

Bike sled hoops can be surface mounted on paved, concrete and asphalt areas.

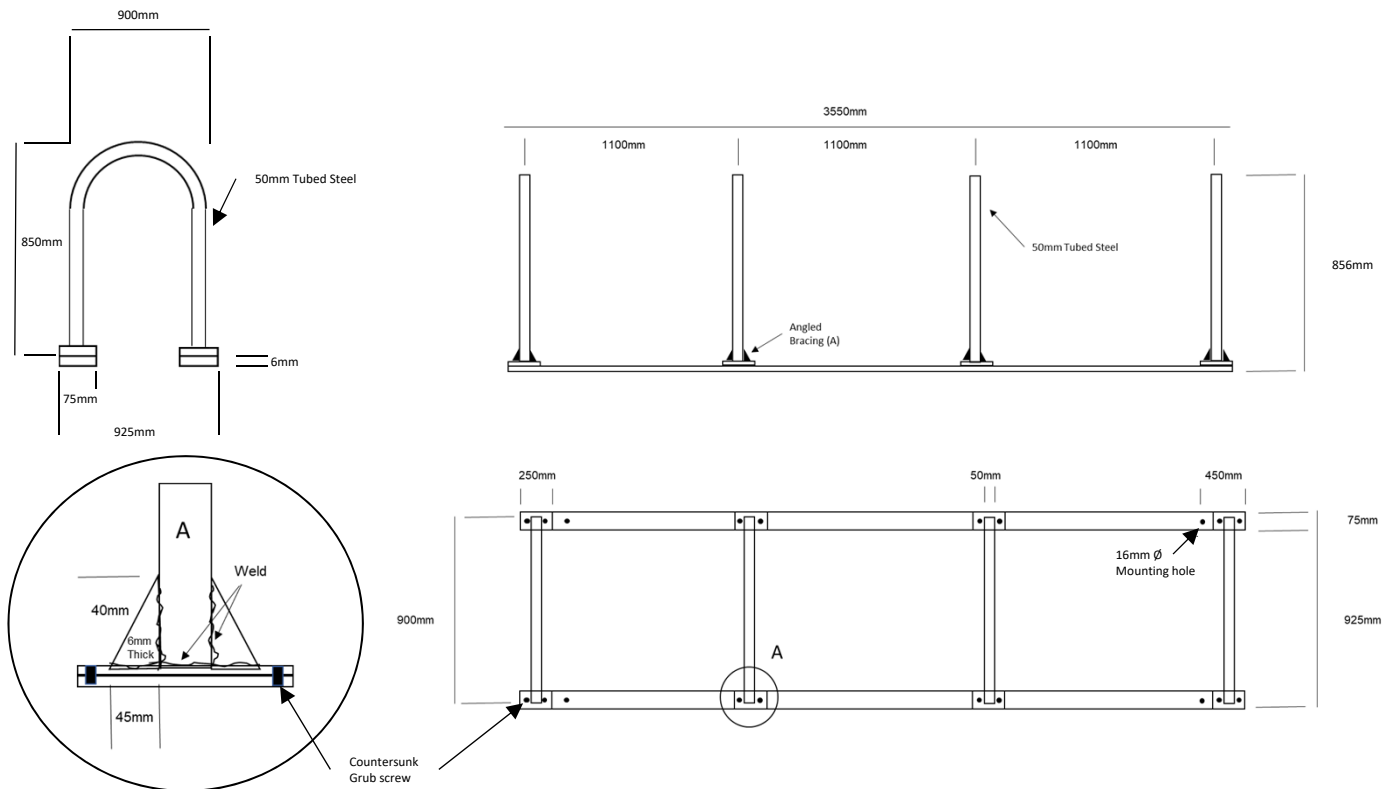

SECTION 16: LABORATORY REFRIGERATORS and FREEZERS

CONTENTS

16.1 INTRODUCTION	3
16.1.1 Overview	3
16.1.2 General Scope	3
16.1.3 Standards and Requirements	4
16.1.4 Definitions	5
16.1.5 Brief Overview Summary	7
16.2 GENERAL INFORMATION.....	8
16.2.1 General Safety Considerations	8
16.2.2 Procurement – New Appliances	9
16.2.3 Relocation of new Appliances.....	9
16.2.4 HVAC Considerations	10
16.2.5 Lighting.....	10
16.2.6 Floors	10
16.2.7 Electrical.....	11
16.2.8 Network Data Point Outlets	15
16.3 ROOM DESIGN STANDARDS	15
16.3.1 Space Allocation Requirements	15
16.3.3 Freezer Farm Facilities	16
16.3.4 Construction Considerations.....	17
16.3.5 Laboratory Entry Point – Considerations.....	17
16.3.6 Sustainability	17
16.4 REMOTE TEMPERATURE MONITORING AND ALARM	17
16.4.1 Background	17
16.4.2 Scope	18
16.4.3 Remote Temperature Monitoring - Setup.....	20
16.4.4 Temperature Monitoring.....	20
16.4.5 Local Temperature Alerts and Alarms	21
16.5 OTHER ULTRACOLD FREEZER - BACKUP SYSTEMS.....	21
16.5.1 Liquid CO2 Backup	21
16.6 ACCESS CONTROL – ROOM SECURITY.....	21
16.6.1 Access Control System.....	21

16.6.2 Freezer Monitoring Via Access Control.....	22
16.7 B.A.S. MONITORING.....	22
16.7.1 Generally.....	22
16.7.2 B.A.S. For Freezer Alarm Monitoring	22
16.8 DESIGN CHANGE AUTHORISATION.....	22
16.9 OPERATIONAL MAINTENANCE, AS-BUILTS, WARRANTIES & MANUALS	22

16.1 INTRODUCTION

16.1.1 OVERVIEW

The University of Melbourne Parkville campus & other campuses contain many buildings that accommodate a variety of laboratories that have installations of laboratory fridges and freezers that store important and valuable substances at specific temperatures. These appliances are usually used to contain biological material of high research value and must be installed appropriately to ensure proper and sustainable operating conditions and, to provide an effective appliance to protect the valuable research material stored within them.

16.1.2 GENERAL SCOPE

This Design Standard provides University of Melbourne Staff, Project Managers, Architects, Electrical Engineers, Electricians, Builders, Security contractors, and others with guidance as to how to install laboratory fridges and freezers, and Ultracold freezer appliances in laboratory environments.

This Design Standard is designed to assist laboratory design practitioners to correctly accommodate moveable refrigeration appliances in laboratories. It also takes into consideration the high value of research materials stored in these appliances and aims to mitigate the risk of the appliance failure impacting on the contents.

The Design Standard document refers to four different types of laboratory Fridge / Freezer appliances – either installed individually in Laboratories or collectively in a dedicated Freezer room; referred to as a Freezer farm.

- 1 Laboratory Refrigerator (Fridge) – nominally operates at +5°C
- 2 Combination Laboratory Fridge and Freezer - nominally operates at +5°C and -20°C
- 3 Laboratory Freezer - nominally operates at -20°C
- 4 Ultracold Freezer - nominally operates at - 80°C

16.1.2.1 Exclusions

- Cool rooms or Freezer rooms or Other Constant Temperature (CT) rooms
- Liquid nitrogen vessels – dewars

16.1.2.2 Cool Rooms or Freezer Rooms or Other Constant Temperature Rooms

This document does not cover the design or installation of cool rooms or freezer rooms which form part of the fabric of the building.

Advice for these specialist facilities are available in:-

- AS/NZS 2982-2010 - Laboratory Design and Construction
- AS/NZS 2243.1:2005 - Safety in Laboratories Planning and Operational Aspects;
- AS 2243 SET (2006): Safety in Laboratories Set

16.1.2.3 Liquid Nitrogen Storage Vessels - Dewars

This document does not cover the storage of research material in liquid nitrogen vessels - dewars, commonly referred to as cyrostorage.

Liquid nitrogen poses a high risk and special storage and handling facilities are required –

For advice on cryostorage refer to:-

- AS/NZS 2981-2010 Laboratory Design and Construction.
- AS 2243.3 (2010): Safety in Laboratories – Part 3: Microbiological safety and containment
- AS 1894 (1997): The storage and handling of non-flammable cryogenic & refrigerated liquids

16.1.3 STANDARDS AND REQUIREMENTS

16.1.3.1 Standards & Requirements

The following Australian Standards are particularly relevant to the design of laboratory refrigerators and freezers.

- AS/NZS 2982-2010 - Laboratory Design and Construction -
- AS/NZS 2243.1:2005 - Safety in Laboratories Planning and Operational Aspects;
- AS 2243 SET (2006): Safety in Laboratories Set
- AS/NZS-60335.2.24 - Australian Electrical Standards - for refrigeration appliances
- AS/NZS_-3000:2007- Electrical Installations

The design consultant is required to produce his own specification which incorporates this section and other sections of the Design Standards, as well as all relevant Legislation, Regulations, Codes of Practice, and Australian Standards

16.1.3.2 Other Related Documents

- AS 1894 (1997): The storage and handling of non-flammable cryogenic & refrigerated liquids
- AS 2243 SET (2006): Safety in Laboratories Set
- AS 2243.3 (2010): Safety in Laboratories – Part 3: Microbiological safety and containment
- AS/NZS 3000.2000 -Australian/New Zealand Wiring Rules;
- AS / NZS 4474:2018 – Energy labelling and minimum energy performance Standards requirements
- AS / NZS IEC 62552:2018 Parts 1-3; Household refrigeration appliances – Characteristics and test methods
- Environment Protection Authority for relevant State
- The Gene Technology Act 2000;
- The Gene Technology Regulations 2001;
- AS 85000:2011 - QCPS - Quality Care Pharmacy Standard - quality management system for pharmacies in Australia;
- AS3864.1-2012 - Medical refrigeration equipment – For the storage of blood and blood products, Part-1: Manufacturing requirements;
- AS3864.2-2012 - Medical refrigeration equipment – For the storage of blood and blood products, Part-2: User-related requirement for care, maintenance, performance verification and calibration;

- Australian Government – National Health and Medical Research Council- Dept. of Industry, Innovation and Science - Australian Clinical Trials

16.1.4 DEFINITIONS

- Access Control – Challenger system – a form of alarm control system - used by Security to control access/egress with electronic door latches and for Security CCTV
- BAS -Building Automation System – used to monitor and send out alerts when there are issues with building operational systems such as HVAC.
- Captive mains power socket “Flip top” GPO – a GPO with a flip top cover to hold the mains plug and prevent the accidental removal of the mains plug
- Captive mains power PLUG industrial type with screw collar fitting – a plug to match captive socket, fitted to mains power flex cable which is attached to an electrical appliance typically an Ultracold freezer
- Captive mains power SOCKET industrial type with screw collar fitting – a mains power outlet with 3 flat pins, which maybe 10A or 15A, to be used with Ultracold Freezers at UoM. Usually fitted to the wall or a pendent style suspended from the ceiling
- Circuit Breaker – a device that is usually fitted to a circuit in a mains power distribution board. It isolates mains power when a high current, short circuit, is detected. It can also be manually activated/ reset to isolate/return mains power to a circuit.
- Commercial Freezer – similar to laboratory freezer
- Commercial Fridge – similar to laboratory fridge
- Converter - a Testo Saveris product - a type of Modem or network access point –that is part of the freezer temperature network. It is typically attached to a wall in the laboratory and establishes a WLAN through a CAT-6 cable attached to an IT network point in the vicinity, usually within 25m, of a Testo Saveris WiFi Data logger.
- Cryogenic Liquids – liquids at very cold temperatures - typically liquid nitrogen (minus) -180°C
- Cyclic defrost - an inbuilt heating cycle to reduce or prevent the build-up of ice in a freezer
- Data-Port – an IT network access point - RJ45 socket
- Dewar – a vessel that contains cryogenic liquids
- D.H.C.P. - Dynamic Host Configuration Protocol. is a network management protocol used to dynamically assign an IP address to any new node entering the network.
- Domestic Freezer – a refrigeration appliance mostly used in a domestic situation – generally has cyclic defrost refrigeration system which, in most cases, is not suitable for laboratory installations
- Dry Ice - a solid form of carbon dioxide, typically at -80 °C refer to solid carbon dioxide. Used for temporary refrigeration i.e. during transport.
- Earth Leakage Detector (ELD) - a type of RCD electrical safety switch
- FCU – Fan Coil Unit - a cooling condenser with an active fan connected to a buildings chilled water system

- Freezer Farm – a dedicated, and suitable fitted room, for a collection of laboratory fridges, laboratory freezers or ultracold freezers. Usually it is a collection of Ultracold Freezers.
- Freezer Temperature Monitoring system - a system that monitors and send out alerts when temperatures are outside a pre-determined high/low setpoint
- I.P. address – Internet Protocol address is a numeric address that identifies an individual item of computer equipment. This can be a static or dynamic number
- Laboratory Fridge - typically a refrigeration appliance, suitable for a laboratory application, that will maintain temperatures above zero (0.0) degrees, at +4 'C
- Laboratory Freezer - typically a refrigeration appliance, suitable for a laboratory application, that will maintain temperatures below zero (0.0) degrees, at around (minus) – 20 'C or – 30 'C
- Liquid Carbon Dioxide – R744 is a form of refrigerant. Usually in a G size cylinder attached to an Ultracold freezer as an optional temporary backup refrigeration system. – the use of liquid carbon dioxide is not recommended as a backup system.
- Liquid Nitrogen – liquid that is very cold and used for cold storage (minus) -180 'C
- Logger – a Testo Saveris product – a type of temperature data logger. Usually a T3D which is fitted to the front of a refrigerated appliance (fridge, freezer or ultracold freezer). The data logger periodically measures the temperature inside the appliance, and stores the data until it transmits the data, wirelessly to the local Converter, and then to the temperature monitoring computing database. The data logger has a temperature probe which is placed inside the appliance to measure the temperature.
- Medical Freezer – similar to laboratory freezer but with more accurate temperature control
- Medical Fridge – similar to laboratory fridge but with more accurate temperature control. Commonly used for Clinical trials or for Vaccine storage
- Network Node - is either a network redistribution point or a communication endpoint such as a data-port
- POE – Power Over Ethernet
- Refrigeration Condenser – a refrigeration heat exchanger usually located at the back, underneath or on top of a refrigeration appliance.
- RCD – Residual Current Device – an electrical safety device that is usually fitted to a mains circuit within a mains power distribution board. The RCD constantly measures the current between the active and earth lines and cuts mains power if it detects any residual current. Usually, an RCD responds very quickly and requires very low current levels to isolate mains power i.e. 10 milli Amp
- Safety Switch- refer to RCD
- Scientific Fridge - similar to laboratory fridge
- Scientific Freezer – similar to laboratory freezer
- Solid Carbon Dioxide – a very cold, solid pellet form of carbon dioxide, typically at (minus) – 80 'C
- Testo Australia Pty Ltd – local supplier of Saveris freezer monitoring equipment
- Testo Saveris – Manufacturer and brand of preferred freezer temperature monitoring equipment at UoM
- Ultracold Freezer – typically a refrigeration appliance that will maintain temperatures as low as (minus) - 80 'C. There are a number of refrigeration systems used for

ultracold freezers - twin compressor cascade systems, single compressor system, dual single compressor system and Stirling engine system.

- Vaccine Fridge - a fridge with a defined operating range typically; +1 to +8 °C
- WLAN –Wireless Local Area Network - a local form of wireless communication
- WiFi – wireless communication system

16.1.5 BRIEF OVERVIEW SUMMARY

Laboratory fridge/freezer and ultracold freezer installations

Procurement:

- All new laboratory fridge, freezers and ultracold freezers must be purchased through a UoM preferred supplier as identified by UoM Procurement Services.
- Laboratory fridges and freezers must be “fit for purpose” and must not be of the domestic variety.
- Refrigeration appliances purchased for UoM from preferred suppliers will come supplied with the appropriate electrical plug and a temperature probe for connection to the UoM Freezer Monitoring system

Electrical:

- Each of the fridges / freezers will require appropriate power for each installation, i.e.; single circuit and flip up captive GPO preferable non-RCD and labelled accordingly
- Ultracold freezers will need a single circuit screw captive, 3pin 10A or 15A, GPO, no RCD on the circuit and labelled accordingly.

Carpentry:

- Appropriate space should be dedicated to fit the fridge or freezer, with a 10-cm space at either side, on top and behind the fridge or freezer – to allow for air circulation.
- Ultracold freezers may require additional space along the side for CO2 backup cylinders, if provided (rarely and not recommended), the space is needed for “G size” gas cylinders
- Laboratory entry doors must have a side leaf to allow for the relocation & passage of large ultracold freezers
- Floor coverings must be laboratory grade vinyl where fridges / freezer or ultracold freezers are located, and edges must be coved to contain liquid spills

Mechanical (HVAC)

- Ventilation and cooling is required to allow for the heat output of fridges and freezers and ultracold freezers. Heat extraction and makeup air supply must be considered.
- Air-conditioning is required to maintain an operating room temperature between 18 to 30°C and must be operational 24/7

Monitoring

- The Freezer Management Unit must be consulted regarding the temperature monitoring of laboratory fridges, freezers and ultracold freezers.
- The construction project must provide one (1) UoM IT network data-port (type RJ45 single or double) in the laboratory containing research fridges or freezers. The data-port must be active, have POE and be patched to the freezer temperature monitoring network by UoM IT. Currently this is VLAN 1200

- The construction project may be required to purchase and supply / provide one (1) Testo Saveris T3D temperature logger per laboratory fridge, freezer appliance. This will be fitted by a specialist contractor.
- The University Preferred Freezer Temperature Monitoring System is the Testo Saveris Freezer Temperature Monitoring System – managed by the Freezer Management Unit within UoM Infrastructure Services
- The University Testo Saveris Freezer Temperature Monitoring System will automatically send notifications indicating “out of normal range” temperature alarms, to designated responsible research staff, by SMS and email.
- All new fridge / freezer and ultracold freezer purchases must be supplied with fitted temperature probes for the UoM monitoring system.
- Existing fridges and freezers will be retro-fitted with temperature probes by specialist contractors or the Freezer Management Unit.
- Each laboratory fridge or freezer will be given a UoM Freezer ID Tag placed on the front top of each appliance by the Freezer Management Unit.
- A Testo Saveris T3D temperature logger and WiFi transmitter will be supplied and fixed to the front of laboratory fridges and freezers by the Freezer Management Unit
- The supplied data-port is used to connect the monitoring “Modem” and is used to setup a local freezer monitoring network WiFi network (WLAN) and can accommodate up to 15 appliances wirelessly.
- The Freezer Management Unit will install the WiFi modem (Converter) for the monitoring service.
- The Freezer Temperature Monitoring Service, will also require the names of 3 research staff, from the Faculty, to receive alarms from the monitoring system. this will be programmed by the Freezer Management Unit.
- In-time, freezer monitoring software will be available to university managed PC computers, through UoM “Viewer Only” software, to enable research staff on the UoM network to view the operating temperatures for their laboratory fridges or freezers

16.2 GENERAL INFORMATION

16.2.1 GENERAL SAFETY CONSIDERATIONS

This Design Standard provides installation requirements of individual or multiple laboratory fridges or laboratory freezers or ultracold freezer appliances that must be considered for the safe and efficient installation of these appliances.

16.2.1.1 Electrical, Size, Weight, Heat Output and Ventilation

Safety aspects must be taken into consideration when planning for the installation of a new appliance or the relocation of existing laboratory fridges, freezers or ultracold freezer appliances.

These include infrastructure aspects of the laboratory fit-out such as:

- electrical mains power supply,
- the size and weight of the appliance
- the heat output of the appliance

- HVAC ventilation and cooling
- Lighting
- Floor covering
- Adequate floor space and passage around the appliance
- Freezer Temperature Monitoring

16.2.2 PROCUREMENT – NEW APPLIANCES

16.2.2.1 Considerations

The University has selected preferred major suppliers of laboratory grade appliances. These suppliers can assist and recommend appropriate laboratory fridges, laboratory freezers and Ultracold freezers.

A range of “fit for purpose” laboratory appliances are available at tendered prices, through the University IProct system, these appliances include laboratory fridges, freezers and Ultracold freezers in various sizes and configurations covering most laboratory and research applications.

The preferred suppliers cover the major range of brands and models of these appliances.

Laboratory fridges and freezers should be “fit for purpose” and must not be of the domestic variety.

Refrigeration appliances purchased for the UoM from preferred suppliers will come supplied with the appropriate electrical plug and a temperature probe for connection to the UoM Freezer Monitoring System.

16.2.3 RELOCATION OF NEW APPLIANCES

16.2.3.1 Considerations.

Wherever possible, domestic fridges and domestic freezers should not be relocated into refurbished laboratory facilities. They should be replaced with ‘fit for purpose’ new laboratory grade appliances due to the risk to research materials from old and unreliable appliances.

Laboratory grade appliances, in good working condition and less than 10 years old, may be relocated and used in refurbished laboratory facilities.

16.2.3.2 Safety & Loaded Weight Considerations

A safety risk assessment should be conducted, considering the size and weight of the appliance, prior to relocating any large laboratory refrigeration appliance.

When considering the relocation of large laboratory fridges, laboratory freezers and ultracold freezers, it should be noted that most appliances have castors that are designed to cope with the stationary total weight load. These castors can usually handle the load for small local movements of the appliance.

Laboratory appliances should not be moved over long distances when fully loaded with contents. Allowance should be made to relocate the contents separately, and then to relocate the empty appliance.

16.2.4 HVAC CONSIDERATIONS

16.2.4.1 Ventilation and Cooling Considerations

A laboratory facility must be designed to adequately reject heat by all fridges and freezers operating within the facility. Full redundancy shall be designed in cooling systems to allow for HVAC equipment failure and maintenance issues. A mechanical engineer must make this assessment.

16.2.4.2 HVAC - Options

Preference is to use outside air ventilation where possible, especially where small numbers of fridges and freezers are contained within the room. However, if active cooling is required then specify in order of preference;

- Controlled chilled water system – dedicated fan coil connected to piped chilled water system within the building
- Self-Contained Cooling system – Split or packaged systems.

Fan coil units, (FCU's) shall be fitted with 3-way control valves and dedicated air filters.

16.2.4.3 Room Temperature Setpoints

Active cooling systems must be set to maintain room temperatures conditions 24 hours, 7 days a week to 22 °C with a dead band of 2 °C.

16.2.4.4 Room Temperature HVAC Monitoring

The Building Automation System (BAS) shall monitor room temperature and display ventilation and cooling system operational details on the head end of the graphic display.

A BAS alarm shall notify University maintenance staff of any abnormal room temperature conditions that occurs within the room ventilation or cooling system.

16.2.5 LIGHTING

Adequate laboratory lighting is essential to provide a safe working environment.

For lighting considerations refer to

- AS/NZS 2982-2010 - Laboratory Design and Construction -
- AS/NZS 2243.1:2005 - Safety in Laboratories Planning and Operational Aspects

16.2.6 FLOORS

16.2.6.1 Floor Coverings

Appropriate floor coverings must be used for laboratory or Freezer Farm facilities.

Typically, continuous vinyl floor coverings with coved edges shall be used.

For appropriate floor coverings consideration, refer to

- AS/NZS 2982-2010 - Laboratory Design and Construction
- AS/NZS 2243.1:2005 - Safety in Laboratories Planning and Operational Aspects

16.2.6.2 Room Flooding Considerations

The room shall be located to eliminate the risk of flooding or ingress of water due to burst pipework occurring nearby. The slope of the floor and adjoining corridors shall impede the natural flow of water, or in the case of a basement facility then an appropriate sump and sump pump shall be installed.

16.2.6.3 Floor Loadbearing Capacity - Weight Consideration

A consultant structural engineer shall confirm that the floor carrying capacity will cope with the anticipated total weight of all the refrigeration appliances within the laboratory facility.

Each laboratory fridge freezer appliance can weigh up to 300Kg (when empty) and an additional allowance should be made for the weight of the contents.

As a guide, allow 0.5 kg for each litre of appliance capacity, for example; for a 700L capacity appliance, 350kg of contents should be added to the nett weight of the appliance.

16.2.7 ELECTRICAL

16.2.7.1 Considerations

The electrical power supply to the laboratory refrigerated appliances shall be arranged to minimise the likelihood of power failure as detailed by the following specific electrical components.

16.2.7.2 Laboratory Electrical Emergency Stop – Isolator buttons

In most cases, laboratory emergency electrical stop isolators are no longer required as these have been superseded by Safety Switches / RCD's for most electrical circuits supplying mains power to laboratories. - refer to figure 1

Laboratory fridges and freezers on dedicated electrical circuits should not be connected to electrical emergency stop buttons unless instructed otherwise and approved by the project manager. Refer to the University Design Standard on Electrical Services section 7



Figure 1 Example of electrical emergency stop red button.

16.2.7.3 Freezer Farm Facility

A new distribution switchboard shall be established within a Freezer Farm facility dedicated to powering all fridge and freezer appliances contained within the room. The switchboard must comply with Section 7, Electrical Services of the Design Standards.

Each refrigeration appliance shall be provided with a dedicated single circuit originating from the Freezer Farm switchboard.

Each refrigeration appliance dedicated single circuit shall be protected by a circuit breaker without an RCD device fitted.

16.2.7.4 Conditions for the exclusion of RCD protection

Extract from AS-3000 for exclusion of RCD protection

- a) The connected equipment is required by the owner or operator to perform a function that is essential to the performance of the installation and that function would be adversely affected by a loss of supply caused by an RCD operation and,
- b) The connected equipment is designed, constructed and used in such a manner that is not likely to present a significant risk of electric shock; and
- c) The socket-outlet in a position that is not likely to be accessed for general purposes and
- d) The socket-outlet is clearly marked to indicate the restricted purpose of the socket-outlet and that RCD protection is not provided. Refer to figure 6 for an example of required GPO signage

16.2.7.4.1 Conditions for Refrigeration Appliances to meet RCD removal requirements

To meet conditions, as described in AS-3000, the refrigeration appliance must be designed, constructed and used in such a manner that is not likely to present a significant risk of electric shock. This will require any new, used or current refrigeration equipment to be assessed to ensure it meets relevant electrical standards (for refrigeration appliances AS/NZS-60335.2.24) prior to connecting it to a non-RCD protected circuit. It will also require the local department to use the appliance in a way that will not introduce risk of electric shock.

16.2.7.4.2 Refrigerated Appliances- operational requirements to meet non-RCD protected circuits

For this to be effective there needs to be a few actions:

1. Existing appliances need to be “tested and tagged” for electrical safety prior to installing on a non-RCD protected circuit.
2. Any refrigeration appliances (new and used) need to be assessed prior to installing on a non-RCD protected circuits. New freezers must meet Australian Electrical Standards (for refrigeration appliances AS/NZS-60335.2.24). Used equipment must be “tested and tagged” for electrical safety prior to installing on a non-RCD protected circuit.
3. Operation of the equipment: must be in a manner that will not introduce significant risk of electric shock.

16.2.7.5 Essential Supply – Backup Power

Consideration shall be given to incorporating a standby backup diesel generator to provide an essential power supply to the Freezer Farm room switchboard. This shall be considered when stand-by power is available.

16.2.7.6 Power Socket Outlets

To reduce the risk of a refrigerated appliance power plug being accidentally disconnected, a captive-type secure mains socket system, as specified in this Design Standard shall be used.

16.2.7.6.1 For Laboratory Fridges & Laboratory Freezers

This is typically a “flip-top” captive GPO, eg; Clipsal- type 10PL refer to figure 2

16.2.7.6.2 For Ultracold Freezers

This is typically a captive screw fitted industrial GPO, eg; Clipsal type 56 series refer to figures 3 & 4

16.2.7.7 Power Plugs

Normally, new refrigeration appliances purchased through the University’s online purchasing system, iProct from preferred suppliers, will be delivered with the appropriate plug fitted. Refer to figures 2,3 & 4

16.2.7.7.1 Individual laboratory Fridges or Freezers - electrical plug requirements

Each laboratory fridge or freezer appliance will be fitted with a standard Australian electrical mains 3 pin plug.

16.2.7.7.2 Ultracold freezers -- electrical plug requirements

Each ultracold freezer appliance **MUST** be fitted with an industrial screw CAPTIVE mains 3 pin plug, Clipsal type 56 series - refer to figure 4

For existing electrical appliances an electrician will need to be contacted to remove and replace the 3 pin plug for ultracold freezers with the recommended industrial captive screw 3 pin plug & matching wall or pendant outlet.

16.2.7.8 Flexible Electrical Cables

The appliance flexible power cable shall be of sufficient length to allow for the appliance to be plugged directly into the captive supply socket without the need for an extension lead or power-board.

If this is not the case then, as required, an electrician will be engaged to replace the flexible electrical cable with one that is of suitable length.

VARIOUS CAPTIVE MAINS POWER OUTLETS, PLUGS and LABELLING

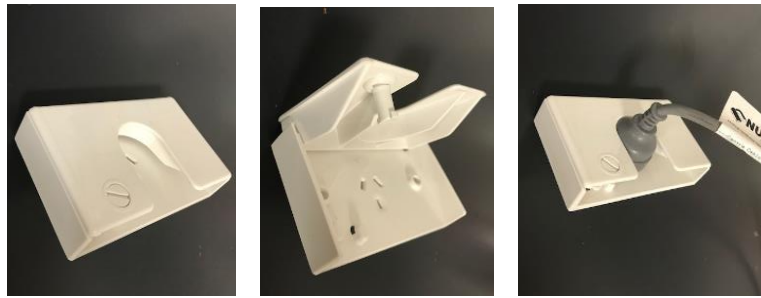

Figure 2 Standard GPO with the “FLIP TOP” cover for fridges and freezers- Clipsal- type 10PL.



Figure 3 Industrial captive screw sockets – wall mounted- Clipsal type 56 series.



Figure 4 Compatible Industrial **captive screw plugs** - Clipsal type 56 series.



Figure 5 Suspended **Pendent type** - Industrial captive screw sockets –

Clipsal type 56 series.



Figure 6 Dedicated circuit - example of required signage for GPO with RCD removed.

16.2.8 NETWORK DATA POINT OUTLETS

16.2.8.1 Consideration

Several network data-points are required for communications such as telephone and Freezer Temperature Monitoring on the University IT network.

The Freezer Temperature Monitoring Program requires one or 2 network data-points near multiple refrigerated appliance installations.

16.2.8.2 Freezer Farm Facilities – network data-port requirements

Freezer Farm facilities require a minimum of two (2) network data-points provided for the Freezer Temperature Monitoring Program – refer to figure 7

16.2.8.3 Other Laboratory Facilities - network data-port requirements

In other laboratory areas, one network data-port shall be reserved for the Freezer Temperature Monitoring Program.



Figure 7 (a) Single RJ45 network socket.

(b) Dual RJ45 network socket.

16.3 ROOM DESIGN STANDARDS

16.3.1 SPACE ALLOCATION REQUIREMENTS

Adequate space for individual laboratory fridges or freezers must be allowed for, as part of the laboratory design.

Consideration should be given to the maximum number of appliances in the facility / laboratory

Free Standing refrigeration appliances MUST not be bigger than 1500 L or wider than 1.5 m

16.3.1.1 Space requirements for air circulation around appliances

Appropriate space should be dedicated to fit the refrigerated appliance in the room, with a 10-cm space at either side, on top and behind the fridge or freezer – this is to allow for air circulation.

Refrigeration appliances typically have heat condensers either on the back or underneath the appliance, it is important to keep heat away from this condenser coil to allow for the proper operation of the appliance.

16.3.1.2 Locating refrigeration appliances in a laboratory

Space should be made available, preferably along an internal wall of a facility / laboratory, to adequately fit the appliances.

16.3.1.3 Laboratory Passage Clearance

Adequate space must be allowed for the movement of people along internal corridors, for when the appliance door is opened.

16.3.1 FLOOR CLEANING AND DUST FREE ENVIRONMENT

The facility design shall be such to provide easy access for floor cleaning and reduce the build-up of dust.

16.3.3 FREEZER FARM FACILITIES

Where a dedicated freezer facility is required, referred to as a “Freezer Farm”, then adequate space must be allowed for each fridge / freezer or ultracold freezer as well as future additions within the Freezer Farm.

The freezer farm shall be sized to adequately fit all current laboratory fridges and freezer, and ultracold freezers.

Some space allowance shall be provided for any future appliance acquisitions that maybe required.

Consideration must be given to the space needed to move appliances in and out for cleaning and maintenance. Sufficient space is required and must be allowed for personnel to access power outlets adjacent to freezers, without the need to move the appliance.

16.3.4 CONSTRUCTION CONSIDERATIONS

A Freezer Farm facility does not require external windows, as these will only introduce unnecessary heating loads. If a proposed Freezer Farm room has existing windows these should be covered with plasterboard and insulation to minimise external heat loads into the room.

The Freezer Farm facility shall be constructed with 2-hour fire rated construction for added protection of Ultracold Freezer appliances in the event of a fire that occurs elsewhere in the building.

16.3.5 LABORATORY ENTRY POINT – CONSIDERATIONS

The laboratory entrance shall take account the passage of large laboratory equipment like laboratory fridges and laboratory freezers.

As a guide, the laboratory entrance should have a minimum opening of a door and side-leaf, or double doors, with manual door closers fitted to both doors. This is to allow for the passage of larger laboratory appliances and equipment such as laboratory refrigeration appliances.

16.3.6 SUSTAINABILITY

16.3.6.1 General Considerations

Consideration of direct and indirect energy usage should be given to the design of the installation of refrigeration appliances in laboratories or dedicated freezer farm facilities.

16.3.6.2 Ultracold Freezers - Energy Consumption and Heat Output

Attention is drawn to Ultracold freezers as they use large amounts of electricity per day, a single Ultracold Freezer uses in the order of 14 kWh / day and produces a high heat output into the room, to maintain the relatively low temperatures inside the freezer cabinet. As a result, these appliances require an uninterrupted power supply and HVAC 24/7 to maintain a cool operating environment.

16.3.6.3 Uninterrupted 24/7 Requirement for Mains Power and HVAC

Multiple Ultracold Freezer units in a Freezer Farm Facility require special consideration. A dedicated switchboard capable of supplying sufficient uninterrupted power to all refrigerated appliances shall be provided.

A 24/7 uninterrupted cooling system shall be provided to Freezer Farm facilities.

16.4 REMOTE TEMPERATURE MONITORING AND ALARM

16.4.1 BACKGROUND

The University of Melbourne has established a Freezer Temperature Monitoring System independent from the Building Automation System (BAS), called the Testo Saveris Freezer Temperature Monitoring System. The Testo Saveris Monitoring System has a dedicated server that is solely responsible for the data logging and monitoring of temperatures originating from Faculty refrigeration equipment, such as Laboratory Fridges, Laboratory Freezers, Laboratory Ultracold Freezers, and other specialised Laboratory equipment such as Laboratory Incubators and storage Liquid Nitrogen tanks.

The objective of the Testo Saveris Monitoring System is to detect and remotely notify laboratory users, and maintenance personnel of the presence of problematic temperatures within important laboratory refrigeration appliances.

The University Freezer Monitoring system uses the Testo Saveris Temperature Monitoring system and is managed by the UoM– Freezer Management Unit, located within Infrastructure Service, together with contractors from Testo Australia.

16.4.2 SCOPE

16.4.2.1 Provision of Freezer Temperature Monitoring Equipment and Setup

The majority of laboratory fridges, freezers or ultracold freezers shall be connected to the University Temperature Monitoring System (Testo Saveris system).

The following system components will be installed by the Freezer Management Unit or a UoM approved contractor-

- For new appliances the Temperature probe with mini connector is supplied and should already have been fitted by the preferred suppliers.
-
- For existing appliances that require Freezer Temperature Monitoring, the Freezer Management Unit will provide the following: -
 - Temperature probe with mini connector; refer to figure 8
 - Freezer identification tag (UoM Freezer ID) – with Location details; refer to figure 9
 - Testo Saveris T3D WiFi Logger & mounting bracket attached to appliance; refer to figure 10
 - Testo Saveris WiFi converter (WLAN-modem) attached to Laboratory fittings; refer to figure 11

TESTO SAVERIS 1 - FREEZER TEMPERATURE MONITORING COMPONENTS



Figure 8 Temperature probe with mini connector.



Figure 9 Freezer ID label.



Figure 10 Testo Saveris 1 - T3D data logger.



Figure 11 Testo Saveris 1 - Converter connected to data port via cat 6 cable.

16.4.2.2. Testo Saveris Data Input

The data logger device will be programmed onto the Testo Saveris Monitoring System and, if the temperature profile is stable, then the Alarm feature will be available to the Faculty.

The Testo Saveris Monitoring System provides alarms, via SMS and email., where “abnormal temperatures” are observed.

16.4.2.3 Faculty Alarm Contacts.

The initial setup, additions and deletions of the Testo Saveris Monitoring Software System “alarm contacts”, will be managed by local laboratory officers in conjunction with the Freezer Management Unit - Infrastructure Services.

The Faculty must provide the names of (maximum) 3 x nominated responsible researchers contact details, to receive Freezer alarms; These details will be initially uploaded into the Testo Saveris software program by the Freezer Management Unit.

16.4.2.4 Testo Saveris Operating System maintained by the Freezer Management team

The University enterprise level - Freezer Management Operating System (the Saveris software) will reside on a secure University Virtual Machine, located in a secure University Computer Data Centre. The Saveris Enterprise software will be managed at the University by the Freezer Management Unit, with the support of the UoM IT Microsoft Platform team, and Testo Australia.

16.4.2.5 UoM Testo Saveris Freezer Temperature Monitoring System

The Testo Saveris Monitoring System consisting of; Testo Saveris Data Loggers, Converters, Base-Station and enterprise Saveris Software will be managed and maintained by the Freezer Management Unit and Testo Australia.

The Freezer Management Unit shall be the first point of contact if there is any maintenance issue with the Testo Saveris Monitoring System or components.

The contact address for the Freezer Management Unit is: -

- **email:-** “ freezer-monitoring@unimelb.edu.au ”

16.4.3 REMOTE TEMPERATURE MONITORING - SETUP

The majority of research laboratory fridges, freezers or ultracold freezer appliances require connection to the Freezer Temperature Monitoring System.

16.4.3.1 Freezer Monitoring setup

Each laboratory fridge or freezer or ultracold freezer appliance will be fitted with a temperature probe with a mini plug, suitable for connection to the Testo Saveris 1, T3 logger. The Testo Saveris data logger is fitted with long life batteries.

16.4.4 TEMPERATURE MONITORING

Each laboratory fridge or freezer or ultracold freezer appliance that contains valuable research material must be connected to a “Temperature Monitoring System with Remote Alarm”. At the UoM most refrigerated appliances shall have its internal temperature monitored by the University enterprise Testo Saveris Freezer Temperature Monitoring system

A Testo Saveris system WLAN must first be established near the laboratory fridge or freezer or ultracold freezer installation. The WLAN shall comprise an RJ45 style outlet and associated Cat 6 cable for the connection of a Testo Saveris Converter. This is to establish the local Testo Saveris WiFi network (WLAN).

The local Testo Saveris WiFi network (WLAN) through the Converter will accommodate up to 15 refrigerated appliance Monitored Data loggers, within a 25-m radius of the Converter.

The data-port outlet, RJ45 outlet must be suitably labelled, patched and activated to the Testo Saveris UoM IT Networks VLAN (currently 1200)

16.4.5 LOCAL TEMPERATURE ALERTS AND ALARMS

16.4.5.1 Ultracold Freezers - local alarm features

Most ultracold freezers are supplied with “local” temperature alarm devices.

The “local” alarm monitors the operational parameters of the Ultracold Freezer including- internal cabinet temperature, external room temperature, condenser temperature, mains power supply, compressor performance and door opening times.

When a “local temperature alarm” is activated it may be an “alert” or an “alarm” and is designed to attract the attention of the research staff that “own” the fridge / freezer. It is the responsibility of the research staff to manage “local ultracold freezer alarms”.

16.4.5.2 Testo Saveris - only measures freezer temperature

The University Testo Saveris Freezer Temperature Monitoring System only measures the temperature inside the ultracold freezer unit. The Testo Saveris Freezer Monitoring System - alarm system is only triggered by fluctuations of temperature that are measured by the temperature probe inside the appliance.

When the Testo Saveris Monitoring System measures a temperature that is not in the normal temperature range, then an alarm is triggered. The Testo Saveris alarm system is independent of the internal Ultracold alarm system and it cannot control the local ultracold alarm system.

Often “local” alarms may be triggered by localised power outages but these do not necessarily trigger a “temperature alarm” on the Testo Saveris System unless the internal cabinet temperature rises significantly to trigger a “temperature alarm”.

16.5 OTHER ULTRACOLD FREEZER - BACKUP SYSTEMS

16.5.1 LIQUID CO₂ BACKUP

Most Ultracold Freezers (minus 80 °C) can be purchased with the option to use a liquid CO₂ backup system to maintain the very cold temperatures within the Freezer in the event of a power outage or other refrigeration problems.

CO₂ backup systems are not recommended because they are not generally reliable. Freezer Temperature Monitoring with remote alarming provides sufficient early notification to prevent spoilage, should a refrigeration problem occur

16.6 ACCESS CONTROL – ROOM SECURITY

16.6.1 ACCESS CONTROL SYSTEM

- Refer to Section 13 of the Design Standards – Security.
Requirements: -
 - Proximity card reader to the outside of the Laboratory / Freezer room.

- Electric lock fitted to the door system.
- Micro-switches to detect if the door has been left open.
- Integration with the University Campus Access Control System.
- Programmed to alert maintenance personnel if door has been left open too long.
- Free handle exit egress through the door.
- Automatic release of door lock during a building fire-alarm.

16.6.2 FREEZER MONITORING VIA ACCESS CONTROL

At all UoM locations Access Control is no longer required for monitoring of laboratory fridges or freezers, or ultracold freezers.

If laboratory fridges or freezers are found to be connected to the Access Control System this must be advised to the Freezer Management Unit in Infrastructure Services for corrective action.

16.7 B.A.S. MONITORING

16.7.1 GENERALLY

B.A.S. monitoring is almost exclusively used to monitor and manage the building infrastructure systems such as HVAC, room temperatures, make up air flow rates, water temperature, water flow rates, pump operational status i.e. “on/off”, mains power supply, diesel generator operational status i.e. on/off, etc

16.7.2 B.A.S. FOR FREEZER ALARM MONITORING

In some areas of the University the B.A.S. system is still used to monitor the alarm status of Ultracold freezers that are located within the building.

The sites include:

- Doherty Institute (Building 248) – also known as the “PDI”
- Kenneth Myer building- (Building 144) - also known as “Neurosciences building”, or the “Melbourne Brain Centre” (MBC)

16.8 DESIGN CHANGE AUTHORISATION

All requests for changes to the requirements of the Design Standards must be made on the Modification Request Form. No design work is to proceed on the basis of a proposed modification, until the modification request has been approved in writing.

16.9 OPERATIONAL MAINTENANCE, AS-BUILTS, WARRANTIES & MANUALS

The Design consultant must ensure that the project documentation includes a requirement for all refrigeration and monitoring items to be provided with a full routine and regulatory maintenance period of at least 12 months from the date of practical completion / commissioning. Any registrations of equipment are to be placed in the University's name prior to practical completion / commissioning.

The University of Melbourne CAD Standards detail the formatting and submission requirements for as-built drawings, manuals, and warranties. The CAD Standards can be found in the Associated Documents section of the Design Standards.

Campus Wayfinding
(Currently under development)

SECTION 18: AUDIO VISUAL DESIGN STANDARDS 2019

CONTENTS

18.1	INTRODUCTION	4
18.2	OBJECTIVES	4
18.3	COLLABORATION ENDPOINTS	4
18.4	PROJECT RESPONSIBILITIES	5
18.5	PROJECT PROCESS	5
18.6	PROJECT STAKEHOLDERS	6
18.7	RESPONSIBILITY MATRIX	7
18.8	AV CONSULTANT	8
18.9	AV CONTRACTOR	9
18.10	VARIATION FROM THE DESIGN GUIDELINES AND CUSTOM DESIGNS	10
18.11	TEACHING SPACES	10
18.12	COLLABORATIVE LEARNING SPACES	10
	18.12.1 Description	10
	18.12.2 AV Equipment	11
18.13	MAJOR LECTURE THEATRE	11
	18.13.1 Description	11
	18.13.2 AV System Functionality	11
	18.13.3 AV Equipment	12
18.14	LECTURE THEATRE	13
	18.14.1 Description	13
	18.14.2 AV System Functionality	13
	18.14.3 AV Equipment	14
18.15	SEMINAR ROOMS	15
	18.15.1 Description	15
	18.15.2 AV System Functionality	15
	18.15.3 AV Equipment	15
18.17	PROFESSIONAL SPACE	16
	18.17.1 Description	16
	18.17.2 AV System Functionality	16
	18.17.3 AV Equipment	17
18.18	TECHNICAL REQUIREMENTS	17
18.19	PROJECTION SYSTEM	17
	18.19.1 Projector Requirements	18
	18.19.2 Lines of Sight	18
	18.19.3 Projection Screen / Surface	18

18.19.4	Projector Configuration	19
18.19.5	Projector Installation	19
18.19.6	Fixed Projector Mount	19
18.19.7	Motorised Projector Lift	20
18.19.8	Dual Projection	20
18.19.9	Triple Projection	20
18.20	FLAT PANEL DISPLAY	20
18.21	FPD Requirements	21
18.22	Installation Requirements	21
18.23	Panel Brackets	22
18.24	Panel Enclosure	22
18.21	INTERACTIVE FPD AND INTERACTIVE WHITEBOARDS	22
18.22	VIDEO SWITCHING	23
18.23	SOUND REINFORCEMENT	23
18.23.1	Microphones	23
18.25	HEARING AUGMENTATION SYSTEMS	24
18.25.1	Hearing Induction Loop	24
18.26	Infra-Red System	25
18.27	Radio Frequency (RF) System	25
18.27	CONTROL SYSTEM	26
18.27.1	User interface	26
18.27.2	Device Integration	26
18.27.3	Programming	27
18.27.4	Shut Down / Motion Sensor	27
18.27.5	Remote Management	27
18.27.6	Remote Power Management	28
18.27.8	IP Address & Asset Schedule	28
18.28	CABLING	29
18.29	CONNECTION PLATES AND FLY-LEADS	31
18.30	POWER AND DATA REQUIREMENTS	32
18.31	LECTERN / TEACHER'S DESK JOINERY	33
18.32	AUDIO VISUAL EQUIPMENT STORAGE	33
18.32.1	Ventilation	34
18.32.2	Power Supply	34
18.32.3	Dimensions of Equipment Cupboards	34
18.32.4	Access to Equipment	34
18.32.5	Cantilevered Cupboards and Bio-Boxes	35

18.32.6	Lighting Inside Cupboards	35
18.32.7	Dimensions and Location of Projection Room	35
18.32.8	Acoustic Isolation	35
18.32.9	Doors	35
18.32.10	AV Equipment Rack	35
18.33	LECTURE CAPTURE	36
18.34	36	
	DIGITAL SIGNAGE	36
18.35	OVERFLOW	36
18.36	MEDIALINKS	37
18.37	AV Links	37
18.38	Media Connection	37
18.37	LIGHTING	37
18.37.1	Lighting Levels	37
18.37.2	Integration	37
18.38	VIDEOCONFERENCING SYSTEM	38
18.38.1	Codec Based Systems	38
18.38.2	Web-conferencing	38
18.39	HANDOVER	39
18.40	DOCUMENTATION AND SUBMISSIONS	40
18.41	TRAINING	41
APPENDIX A	STANDARD TOUCH PANEL AND KEYPAD LAYOUTS	
APPENDIX B	APPROVED AV EQUIPMENT MANUFACTURERS	
APPENDIX C	AV COMMISSIONING SHEET TEMPLATE	
APPENDIX D	UOM ASSET AND IP SCHEDULE TEMPLATE	
APPENDIX E	UOM STANDARD LECTERN DESIGN	
APPENDIX F	DIGITAL SIGNAGE COMMISSIONING SHEET	

DOCUMENT CHANGE LOG

Revision	Summary of Changes/Section	Prepared/ Updated	QA Checked	Approved	Issue Date
A	Approved Issue	BG	DK	PC	7-3-2019
B	Updated with UoM comments	DK			19-3-2019
C	Appendix A Updated	DK			22-3-2019

18.1 INTRODUCTION

This section provides details of minimum requirements for the design, installation and operation of audio-visual services. These design standards supersede 'The University of Melbourne Teaching Space Design Standards (2018) and shall be read in conjunction with other sections of 'The University of Melbourne Design Standards'.

Both project management and design standards apply to all learning spaces, professional spaces and digital signage. The critical role of learning spaces for the University and the specialised nature of learning space design means that particularly rigorous standards of design and construction are required which are reflected in the standards.

The Designer is expected to produce their own specification incorporating the elements of the following information and submit all designs to the University for review prior to any works commencing on site. This design standard sets out the University's minimum requirements and shall be considered an adjunct to all relevant statutory regulations.

18.2 OBJECTIVES

Teaching spaces throughout the University are places of social and personal interaction, where learning takes place and where creative thinking is encouraged. The primary objective of this design standard is to provide a consistent arrangement of all audio visual systems on campus such that operation, maintenance and management are simplified.

This document aims to prescribe a list of recommendations and considerations that should be included in designing audio visual systems for teaching, learning and professional spaces. It is recommended that all spaces are specifically designed to meet the user group's requirements and be coordinated by Collaboration Endpoints.

18.3 COLLABORATION ENDPOINTS

Collaboration Endpoints is the team responsible for maintaining the University's teaching, learning and professional space standards. Collaboration Endpoints sits within the Digital Workplace Team in Client Services. Collaboration Endpoints are responsible for inspecting new audio visual installations in these spaces prior to handover to ensure that works are completed satisfactorily and meet the standards herein.

The AV Consultant shall invite a representative of Collaboration Endpoints to meetings with the end users when issues relevant to audio visual equipment are discussed and shall coordinate with the Collaboration Endpoints representative prior to completion of the design.

Any variation from the selection of audio visual equipment currently being used must be authorised by the Collaboration Endpoints representative in writing.

Collaboration Endpoints contact details are:

The University of Melbourne – Collaboration Endpoints

Level 1, 11 Barry St Carlton, VIC

Email: dwt-collaborationendpoints@lists.unimelb.edu.au

18.4 PROJECT RESPONSIBILITIES

Each project team shall include a representative of the User Group to provide user input. However, the project team shall take account of the fact that some of the University's learning spaces are common learning spaces and may be used by other departments.

It is the responsibility of the AV Consultant to ensure adherence to the standards herein, and to liaise with the User Group, Collaboration Endpoints staff and the University appointed Project Manager/ Project Services representative.

18.5 PROJECT PROCESS

AV Projects follow a similar format to standard construction project management processes and include the following phases:

Design	Workshops are conducted and AV system requirements are established, including specific functional and technical requirements. Preliminary design options are produced by AV Consultant with preliminary cost estimates for AV services. Options are presented with Collaboration Endpoints and stakeholders for consideration.
Contract documentation	Preferred design option is developed further. System design schematics, AV drawings and technical specification are produced for tender. All AV services are coordinated with architectural and engineering services. A detailed, pretender cost estimate is produced.
Tender	AV documentation is issued for tender to an endorsed list of specialist AV Contractors. Tender submissions are evaluated for their technical and commercial merit and tender recommendation is provided by AV Consultant. Project Manager engages AV Contractor for the project.
Construction	AV Contractor installs, programs and commissions AV systems as specified. AV Contractor coordinates works with the Head Contractor and other trades as necessary. Any issues, questions or clarifications are issued to Project Manager as an RFI. AV Consultant responds to RFIs formally as a Consultant's Advice Notice (CAN).

Handover	Handover occurs once systems have been installed and tested. Complete written test results are submitted to AV Consultants. AV Consultant conducts an independent inspection of AV systems to verify AV test results. All defects identified are issued to AV Contractor as a CAN to rectify. Practical completion is awarded by Project Manager once all items noted in Section 20.36 have been addressed.
-----------------	---

18.6 PROJECT STAKEHOLDERS

The following stakeholders will generally be involved in University projects:

Architect	External consultant engaged to design the overall teaching space and coordinate all services. On occasion acts as superintendent.
AV Consultant	External consultant engaged to design and coordinate the installation of the audio visual system. The AV Consultant shall liaise with all other stakeholders listed below. On projects where no external AV Consultant is present, the role of designer will be undertaken by a Collaboration Endpoints Engineer.
AV Contractor	External contractor engaged to perform audio visual works
Collaboration Endpoints	University representatives who are responsible for the maintenance of audio visual standards within the University.
Project Services	Typically assigned as Project Managers for projects.
Services Consultant	External consultant engaged to design and coordinate installation/modification of engineering services for teaching spaces.
Support Centre	Responsible for maintenance and management of audio-visual systems once installed
User Group	University representative selected to outline specific requirements for the teaching space.

18.7 RESPONSIBILITY MATRIX

The following table outlines the project team's typical responsibilities.

Task	Architect	AV Consultant	Collaboration Endpoints	Property Services PM	Services Consultant	User Group
Attend project workshops/meetings	R	R	R	R	R	R
Learning & Professional spaces and design	R	C	C	C	C	C
Furniture and joinery	R	C	C	C	C	C
AV system design	C	R	C	I	I	C
Electrical/Data cabling Services	C	C	I	C	R	I
Mechanical Services	C	C	I	C	R	I
Fire Services	C	C	I	C	R	I
University LAN/WAN access	I	I	I	R	C	I
Networks switches	I	I	I	R	C	I
Wireless Access Points	I	I	I	R	C	I
Computers, monitors, keyboards etc	I	C	R	I	I	C
Telephones	I	I	I	R	C	I
Echo Systems	I	C	C	R	I	C
Videoconferencing system setup (IP/PSTN details)	I	C	C	R	I	C
IP addresses (general)	I	C	C	R	I	I
AV Remote Management setup	I	R	C	C	I	I
Touch panel layouts and icons	I	R	C	C	I	C
Lighting pre-sets and configurations	I	C	C	C	R	C
MATV Services	I	C	C	R	C	I

Task	Architect	AV Consultant	Collaboration Endpoints	Property Services PM	Services Consultant	User Group
Padlocks for AV equipment	I	I	C	R	I	I
TEC and LEC locks	I	I	I	R	I	I
Room Booking	I	R	I	I	I	I

R - Member of the project team who is responsible for documentation of the task

C - Requires coordination with this member of the project team

I - Must inform this member of the project team

N - Not involved with the nominated task

18.8 AV CONSULTANT

The audio visual consultant will be engaged by Project Services and/or Collaboration Endpoints. In the case of minor works Collaboration Endpoints may perform the role of AV consultant. Otherwise, the AV consultant must be selected from the University's approved AV Consultant panel.

The AV Consultant will be responsible for the design and the coordination of the delivery of all AV services. The Consultant must be strictly versed on the University design standards and must ensure that all systems strictly comply with University standards and best practice.

As a minimum AV Consultant must have the following qualifications:

Qualification	Mandatory	Preferable
AVIXA/Infocomm Certified Technology Specialist (CTS)	✓	
AVIXA/Infocomm Certified Technology Specialist – Design (CTS-D)		✓
Extron XTP Systems Engineer Certification	✓	
Minimum 4 years Industry Experience	✓	

As a minimum, the AV Consultant must be responsible for the following works:

- Attend design workshops and document AV services requirements as nominated by Stakeholders. All requirements must be captured formally as part of meeting minutes and/or Return Brief for formal acceptance.
- Produce AV systems designs to be issued for approval by Collaboration Endpoints . System design shall include:
 - Video system schematic
 - Audio system schematic
 - Control system schematic
 - Cable schedules

- AV equipment rack layout
- Produce AV drawings for coordination with Architect and Services Engineer. Drawings shall include:
 - Floor plan indicating locations of AV equipment
 - Elevations
 - Reflected ceiling plans
- Produce technical specification for tender. Technical specifications shall include:
 - AV scope of works
 - Functional and technical description of each system
 - Technical specifications
 - Installation requirements
 - Details of coordination with other trades
 - Specific access requirements and working conditions
 - Details of defects liability and warranty
- Project coordination during installation including:
 - Review shop drawings produced by AV Contractor
 - Respond to RFIs issued by AV Contractor
 - Provide design advice as requested by Project Manager
 - Coordinate integration with other services
 - Coordinate commissioning and testing of AV systems
- Conduct independent inspection of AV systems to ensure it meets Stakeholder requirements
- Review training material and coordinate training
- Review as-built documentation and operational manuals

18.9 AV CONTRACTOR

The audio-visual Contractor must be enlisted with Property and Campus Services and Collaboration Endpoints . The Contractor must be on the University approved AV Contractor panel as a specialist AV Contractor, in order to be appointed to undertake any AV works at the University of Melbourne. Organisations that are not on the University AV Contractor panel are not permitted to undertake any AV works for the University.

AV Contractors carrying out works must have appropriate experience and qualifications required of their trade. As a minimum AV Contractors must have the following certifications:

Qualification	Mandatory	Preferable
AVIXA / Infocomm Certified Technology Specialist (CTS)	✓	
AVIXA / Infocomm Certified Technology Specialist – Design (CTS-D)		✓

Qualification	Mandatory	Preferable
AVIXA / Infocomm Certified Technology Specialist – Installation (CTS-I)	✓	
Extron XTP Systems Engineer Certification	✓	
Extron XTP Systems Technician Certification	✓	
Extron Control Specialist Certification (ECS)	✓	
Extron Control Professional Certification (ECP)	✓	
Biamp Audia, Nexia, Tesira Certification	✓	

The AV Contractor must appoint an installation manager who will act as a single point of contact throughout the delivery of the project and have enough experience to be able to ascertain if the works carried out are fit for purpose.

AV Contractors must undergo induction of the University site procedures prior to commencing work. AV Contractors must adhere to and observe all safety, security and administrative rules and regulations by the University as well as local, state and federal regulations.

18.10 VARIATION FROM THE DESIGN GUIDELINES AND CUSTOM DESIGNS

Variation and changes to the AV Design Guidelines may be considered for a project for a number of reasons, including unique user requirements, building environment, change in equipment supply etc.

Any variation may only be considered by way of a variation request form, submitted to Collaboration Endpoints for approval using the UoM Modification Request Form. Requests for variation must identify the scope of the change, the reason for the change and any impact or risk to the project and ongoing operations.

18.11 TEACHING SPACES

The following sections describes the various types of learning spaces at the University of Melbourne, their minimum audio-visual functional requirements and recommended equipment.

Each type of learning space, as outlined below, has differing design considerations according to their intended use. The design of each space shall be coordinated closely with architectural, faculty and services requirements.

18.12 COLLABORATIVE LEARNING SPACES

18.12.1 Description

Collaborative learning spaces are unique teaching spaces designed to enhance and facilitate adaptable teaching, interaction and shared communications. A range of different models have been developed by the University to bring about the functionality required for these spaces. Some spaces are fitted out with several complex integrated AV and IT systems whilst others are provided with simplistic presentation systems.

The specific designs for each collaborative room shall be developed to meet the requirements of the User Group on a project by project basis. Typically, all collaborative spaces will allow for some of the following functionalities:

- Students to interact with the teacher via the installed computer
- Students to work in large or small individual groups
- Student groups to share content with other student groups
- Students to present to entire class
- Teacher to monitor each student computer
- Interactive capabilities via interactive flat panel display (FPD), interactive whiteboard, tablet PC or touch screen
- Capacity to connect laptop or other 3rd party device to share multimedia content with classroom.

18.12.2 AV Equipment

AV equipment nominated for collaborative classrooms will vary to suit specific teaching requirements. Equipment manufacturer and technology must be consistent with University standards and quality to ensure that it can be readily supported by Collaboration Endpoints staff.

18.13 MAJOR LECTURE THEATRE

18.13.1 Description

Major lecture theatres are generally single function spaces with fixed seating and writing furniture on a tiered or sloping floor surface with a seating capacity of 150 or more. Each seat should have a clear unobstructed view to the lecturer and to all boards and screens located on the presentation wall. These spaces are generally well equipped for audio visual equipment including projection system, dedicated sound reinforcement system; touch panel control system and playback equipment installed within a dedicated lectern. The AV system including theatre lighting must be operatable via an integrated touch panel control system.

18.13.2 AV System Functionality

As a minimum, major lecture theatres shall be provided with the following audio visual system functionality:

- Dual video/data projection to display the following sources:
 - University supplied computer
 - Laptop connection(s)
 - Document camera(s)
- Local preview of all sources on lectern monitor(s) (not required for iMacs)
- All source audio shall be via front of house speakers
- All microphone audio shall be reinforced via ceiling mounted speakers
- The hearing augmentation system shall provide 80% coverage of the entire space with low spill to adjacent spaces. The induction loop shall take a combined feed of source and microphone audio.
- Audio output plate on lectern or nominated location for recording/ media feed (mix of microphone and source audio)

- Dedicated audio output (XLR connection) from audio DSP for web-conferencing applications (Skype, Zoom etc.) Located at lectern.
- Provision to integrate Echo Systems
- The control system processor and touch panel, as a minimum, shall interface with the following equipment:
 - Video matrix switch
 - Digital Audio processor
 - Video/data projectors
 - Motorised screen(s) (as required)
 - Motorised projector lift (as required)
 - Motion sensor
 - Equipment rack power controller
 - Room lighting dimmers
 - Extron GVE network (via the LAN)
- A fixed lectern installed at the front of the theatre to house the following AV equipment:
 - University supplied computer
 - Laptop input connection plate (mounted above the lectern)
 - Touch panel
 - Boundary microphones
 - Document camera(s)
- All other AV equipment shall be securely installed in a dedicated full height AV equipment rack. AV equipment rack shall be securely locked in a dedicated cupboard locked with a University standard 'TEC lock'.

18.13.3 AV Equipment

As a minimum, major lecture theatre shall be provided with the following audio visual equipment:

- 2 x Video/data projectors
- University supplied computer
- Laptop input connection plate(s)
- Document camera(s)
- Front of house speakers
- Ceiling mounted speakers
- Wired boundary microphones
- Wireless lapel microphone system and charging dock
- Wireless handheld microphone system and charging dock
- Hearing augmentation system
- Video matrix switch
- Digital audio processor

- Audio amplifiers and 100V line transformers
- Touch panel
- Control system processor
- Dedicated local AV network switch if required
- Echo 360 Systems
- Dedicated AV equipment rack
- Motorised projection screen (as required)
- Motorised projector lift (as required)
- Fixed lectern

18.14 LECTURE THEATRE

18.14.1 Description

Lecture theatres shall have a capacity of 60 to 150 and are designed for presentation of video/data via a single projector. The AV system, input devices and theatre lighting shall be controlled via a dedicated wired touch panel installed on the University standard lectern.

The lectern, as a minimum, shall house one University supplied computer, document camera, laptop connection plate, and touch panel. All audio visual switching and processing equipment shall be housed in a dedicated audio visual equipment rack located in a separate cupboard/joinery.

Voice reinforcement shall include wired and wireless microphones along with ceiling speakers and a hearing augmentation system.

Lecture theatres may be tiered or have a levelled floor.

Lighting shall generally be controlled using a self-standing lighting control system accessed by a wall panel offering a limited number of standard lighting scenes and the option of ramping audience and board lighting.

18.14.2 AV System Functionality

As a minimum, lecture theatres shall be provided with the following audio visual system functionality:

- Single video/data projection to display the following sources:
 - University supplied computer
 - Laptop connection(s)
 - Document camera
- Local preview of computer on lectern monitor(s) (not required for iMacs)
- All source audio shall be via front of house speakers
- All microphone audio shall be via ceiling mounted speakers
- The hearing augmentation system shall provide 80% coverage of the entire space with low spill to adjacent spaces. The induction loop shall take a combined feed of source and microphone audio.
- Audio output plate on lectern or nominated location for recording/ media feed (mix of microphone and source audio)

- Dedicated audio output (XLR connection) from audio DSP for web-conferencing applications (Skype, Zoom etc.) Located at lectern.
- The control system processor and touch panel, as a minimum, shall interface with the following equipment:
 - AV media presentation switch
 - Digital audio processor
 - Video/data projector
 - Motion sensor
 - Equipment rack power controller
 - Extron GVE network (via the LAN)
- A fixed lectern installed at the front of the theatre to house the following AV equipment:
 - University supplied computer
 - Laptop connection plate(s)
 - Touch panel
 - Document camera
- All other AV equipment shall be securely installed in a dedicated AV equipment rack. AV equipment rack shall be securely locked in a dedicated cupboard locked with a University standard 'TEC lock'.

18.14.3 AV Equipment

As a minimum the lecture theatre shall be provided with the following audio visual equipment:

- Video/data projector
- University supplied computer
- Laptop connection plate
- Document camera
- Front of house speakers
- Ceiling mounted speakers
- Wired boundary microphones
- Wireless lapel microphone system and charging dock
- Wireless handheld microphone system and charging dock
- Hearing augmentation system
- AV media presentation switch
- Digital audio processor (if required)
- Audio amplifiers and 100V line transformers
- Touch panel
- Control system processor
- Dedicated local AV network switch if required
- Echo 360 Systems

- Dedicated AV equipment rack
- Fixed lectern

18.15 SEMINAR ROOMS

18.15.1 Description

Seminar rooms have a capacity of up to 56 people but typically have classes of 30 people. The use of different presentation media is restricted.

The AV system shall typically comprise of a projection system or large format FPD (depending on the size of the space), and front of house sound reinforcement. All systems shall be controlled via a dedicated push-button keypad or touch panel. Control system shall be interfaced with all AV equipment.

18.15.2 AV System Functionality

As a minimum, seminar rooms shall be provided with the following audio visual system functionality:

- Video/data projector or FPD to display the following sources:
 - University supplied computer
 - Laptop connection(s)
 - Document camera
- All source audio shall be via front of house speakers
- The control system processor, as a minimum, shall interface with the following equipment:
 - AV media presentation switch
 - Digital audio processor
 - Video/data projector / FPD
 - Motion sensor
 - Equipment rack power controller
 - Extron GVE network (via the LAN)
- A teacher's desk installed at the front of the room to house the following AV equipment:
 - University supplied computer
 - Laptop connection plate
 - Push button keypad / touch panel
- All other AV equipment shall be securely installed in a dedicated AV equipment rack. AV equipment rack shall be securely locked in a dedicated cupboard/joinery locked with a University standard 'TEC lock'.

18.15.3 AV Equipment

As a minimum the seminar rooms shall be provided with the following audio visual equipment:

- Video/data projector
- FPD (optional)

- University supplied computer
- Laptop connection plate(s)
- Document camera
- Front of house speakers
- AV media presentation switch
- Digital audio processor
- Wired boundary microphones (optional)
- Wireless lapel microphone system and charging dock (optional)
- Wireless handheld microphone system (optional)
- Hearing augmentation system
- Audio amplifier
- Push button keypad / touch panel
- Control system processor
- Dedicated local AV network switch if required
- Dedicated AV equipment rack
- Fixed teacher's desk joinery

18.17 PROFESSIONAL SPACE

18.17.1 Description

Professional spaces are designed for staff, students and other users. Consult with Collaboration Endpoints for more detailed standards regarding staff meeting spaces in 2019.

Room types may include:

- Huddle Spaces up to 4-5 people
- Meeting rooms from 5 - 9 people
- Large Meeting Rooms from 10–12 people
- Boardrooms and Multipurpose spaces for 12 people and over
- Stand-up style meeting spaces
- Project Rooms, student presentation spaces

These rooms are basic in their design and layout with tables and chairs, one panel whiteboard as well as a flat panel display (or projector depending on the size of the space) and AV playback devices. AV system shall be controlled by a push-button keypad / touch panel.

18.17.2 AV System Functionality

As a minimum, Professional spaces shall be provided with the following audio visual system functionality:

- FPD / projector to display the following sources:
 - University supplied computer or Unified Communications Engine
 - Laptop connection(s)

- Wireless presentation system
- All source audio shall be via front of house speakers
- All staff meeting spaces should be enabled with the University's preferred soft-conferencing and collaboration platform. *Consult with Collaboration Endpoints.*
- Source equipment shall be directly connected to the FPD
- The control system processor and touch panel, as a minimum, shall interface with the following equipment:
 - FPD / projector
 - Motion sensor
 - Equipment rack power controller if present
 - Extron GVE network (via the LAN)

18.17.3 AV Equipment

As a minimum the Professional spaces shall be provided with the following audio visual equipment:

- Display: FPD / Projector / Interactive FPD
 - Displays smaller than 80" may be interactive where practical
 - Interactive FPD for all stand-up meeting spaces
- Front of house speakers if required (in-built flat panel display speakers can be used for smaller spaces)
- University supplied computer
- Laptop connection plate(s)
- Wireless presentation system
- Push-button keypad / touch panel
- Control system processor
- Skype & Zoom Compatible Cameras and microphones for web conferencing (not required for stand-up meeting spaces)

18.18 TECHNICAL REQUIREMENTS

The following sections detail the minimum technical requirements for audio visual equipment specified in The University of Melbourne's teaching spaces.

The make and models of all audio visual equipment nominated for The University of Melbourne teaching spaces shall be verified by Collaboration Endpoints prior to installation. A list of AV equipment manufacturers currently supported by Collaboration Endpoints is included in Appendix B.

18.19 PROJECTION SYSTEM

Projection systems play a primary role at the University and are present in the majority of learning spaces across the campus. It is imperative that the projection system for these spaces meet the technical and functional requirements of the space.

Engineers shall confirm make, model and specifications of projector with a Collaboration Endpoints representative prior to finalising system configuration.

As a minimum, projection systems at the University of Melbourne shall comply with the following:

18.19.1 Projector Requirements

As a minimum, nominated video/data projectors shall adhere to the following standards:

- Minimum of 4000 ANSI lumens. The specific brightness of the projector shall depend on the application and the particular space.
- Minimum contrast ratio 2000:1. The specific contrast of the projector shall depend on the application and the particular space.
- Capacity to support 4:3 and 16:9 aspect ratios
- Native 1920 x 1080 resolution
- As a minimum, projectors shall include the following video inputs:
 - HDMI
 - HDBaseT
- RS232 / Ethernet controllable
- Ethernet interface (for management)
- Lamp-less technology (e.g. laser)
- Low noise
- Ceiling mountable

18.19.2 Lines of Sight

Optical calculations shall be performed to determine suitable projection parameters for each space; however, the following standards shall be applied:

- Furthest Viewer – no student shall be further than 5.3 image height lengths from the projection surface
- Closest Viewer – no student shall be closer than two screen height lengths from the projection surface
- Horizontal Viewing Angle – audience shall be positioned within an arc of 45 degrees from either side of the centre line of projection
- Vertical Viewing Angle - audience shall be limited to 15 degrees maximum head tilt above horizontal, in relation to the centre of the projection image
- Image position – The base of the projected image should be at least 1200AFFL

Whilst the horizontal viewing angle and closest viewer rules are slightly flexible, the furthest viewer rule is not flexible at all.

The size and the height of the image shall take into account environmental considerations such as ceiling height, ceiling mounted equipment, furniture, audience seating position etc.

18.19.3 Projection Screen / Surface

The projection image shall be located in the centre of the front of house, or in the case of two images (which may include writing space) each shall be situated on either side of the centre. Where possible the projection system shall be able to be used simultaneously with writing boards.

Projection walls shall be a non reflective surface painted matte white. Projection shall be above or behind the writing board area, which may be lowered to expose the projection surface.

If required, fixed and motorised projection screens shall be provided. The projection screen shall be sized to suit the space and a 16:9 aspect ratio.

Motorised projection screens shall be quiet and robust and when recessed, shall be flush mounted within the ceiling cavity where possible. The screen must move from recessed position to presentation position within 25 seconds. Screens shall be individually controlled via the touch panel control system.

18.19.4 Projector Configuration

The projector must be configured for optimal image reproduction. The projector must be configured with the following settings:

- Colour matching – for side by side projectors
- Panel alignment – adjust if necessary, will fine tune colour and make image sharper
- Eco mode – switch off Auto Dim feature

18.19.5 Projector Installation

Video/data projectors shall be securely installed on either a ceiling bracket or within a dedicated bio-box depending on the requirements of space.

The following considerations shall be taken into account when positioning the video/data projector:

- Presentation position – The projector shall be installed such that the projected image is not obstructed by the lectern or the presenter. Consideration shall also be taken to ensure that the presenter is not affected by the glare from the projection angle.
- Projection image size – Each projector manufacturer recommends an optimal installation distance for a given projected image. Engineers shall ensure that a suitable lens is provided for the desired position.
- Ease of maintenance – Consideration shall be taken to ensure that the projector is accessible for maintenance purposes. It is preferred that projectors are not installed above stairs or un-sturdy surfaces where ladders cannot be placed.
- Other ceiling mounted services and equipment – Projection image should not be obstructed by other ceiling mounted services such as security cameras, light fitting, air-conditioning ducts etc.
- Security – Projector shall be installed in a location where it is not easily accessible and prone to damage or theft.

Projector shall be installed on fixed ceiling mount bracket or motorised projector lift.

18.19.6 Fixed Projector Mount

Each projector shall be fitted on a University approved mounting bracket/mounting plate with University standard security screws and high tensile steel padlocks. The mounting bracket shall be fitted to a compatible dropper which is then fixed directly to the ceiling slab. The projector shall be installed such that the projector aligns horizontally with the top of the projected image and electronic image correction or adjustment shall not be required.

Electronic image correction or keystone adjustments shall only be used if prior approval is provided in writing by Collaboration Endpoints.

University preferred mounting bracket is an 'Ultralift Spyder (Uni-Melb) bracket' make and model.

18.19.7 Motorised Projector Lift

Where possible, video projectors shall not be mounted higher than 2700AFFL. If projectors cannot be mounted within 2700AFFL on a fixed bracket, then a University approved custom built mechanical lift shall be fitted.

The projector shall be fitted within the lift cage with University approved security screws and high tensile steel padlocks. The cage shall be modified to suit the projector. The cage should allow for removal and servicing of projector lamps, filters and lenses without having to remove the projector from the cage (often the underside of the cage is cut out to allow access).

The lift shall be cabled back to the AV control system and controlled by the touch panel. Furthermore, IR bud and remote control shall be provided as a failsafe.

The projector lift shall be installed securely on ceiling slab and configured for single stage drop, for service only. When projector is retracted to home position, it must be in show mode. Service height shall be approximately 1500AFFL.

CAT6A cabling must be used for all audio, video and control signals. Cabling must be terminated on connection plate within the ceiling adjacent the lift with braided cable down to the receiver/projector.

Electronic image correction and keystone adjustments shall only be used if approved in writing by Collaboration Endpoints.

University preferred projector lift is an Ultralift Unilift 2, custom modified to suit specific projector.

18.19.8 Dual Projection

Dual projection systems shall have two images projected side-by-side ensuring that they do not overlap. Each projected image shall be of the same size, brightness and contrast. It is recommended the same projectors are used in dual projection rooms.

The AV control system shall be flexible enough to allow the user to select any input source, to be displayed on either or both of the projection systems concurrently. Echo 360 Systems shall be configured to capture left projections by default.

18.19.9 Triple Projection

Triple projection systems shall have three images projected side by side ensuring that they do not overlap. Each projected image shall be same brightness and contrast. It is recommended the same projectors are used in triple projection rooms.

The AV control system shall be flexible enough to allow the user to select any input source, to be displayed on any one, two or all of the projection systems concurrently. Echo 360 Systems shall be configured to capture the left and centre projections (selectable via the control system).

18.20 FLAT PANEL DISPLAY

Flat panel displays are used in smaller tutorial rooms and collaborative classrooms and professional spaces where video/data projectors are not suitable. The installation

requirements for flat panel displays are governed by the same rules as the projections system.

The University of Melbourne currently only deploy FPD within teaching spaces. The following table lists the recommend panel size for the furthest viewer.

Flat panel display size (diagonal)	Recommended Furthest viewer	Recommended Closest viewer
32"	2.0m	0.8m
40"	3.0m	1.0m
46"	3.5m	1.0m
52"	4.0m	1.5m
55"	4.0m	1.5m
65"	5.0m	1.5m
70"	6.0m	1.5m
80"	7.0m	1.5m
84"	7.5m	1.5m
98"	8.5m	1.5m

18.21 FPD Requirements

As a minimum, the nominated FPD shall adhere to the following requirements:

- Minimum HD resolution 1920 x 1080
- Widescreen, 16:9 aspect ratio
- High brightness
- Minimum 800:1 contrast ratio
- Standard sizes (as nominated in the table above) to meet room requirements
- NTSC/PAL Colour system
- RS232 / Ethernet controllable
- VESA compliant, wall mountable
- As a minimum, the panel shall include the following inputs:
 - HDMI x 2
- Optional input slots for twisted pair receivers, TV tuners, HDBaseT, cards readers etc.
- Optional speakers

18.22 Installation Requirements

FPDs shall be fitted with University approved mounting bracket with high tensile University padlocks and security mechanisms to prevent theft or malicious damage. The security mechanisms shall meet the University's security requirements. Any modifications to the installation bracket or security mechanisms shall be approved by Collaboration Endpoints.

Final height of FPDs shall be coordinated with architectural drawings and optimal viewing angles. Ceiling mounted FPDs and panels mounted at high levels shall be angled down to ensure image integrity. Where FPDs have equipment installed behind or if panel is recessed, an articulated bracket must be installed to allow for servicing.

Interactive whiteboards or FPDs with touch overlays shall be installed so the top of the board is no higher than 2000AFFL.

18.23 Panel Brackets

The bracket shall be from a reputable manufacture (Vogel, Ultralift, Atdec, etc.) and be approved by Collaboration Endpoints prior to installation

18.24 Panel Enclosure

FPDs installed in public and unsecured areas shall be fitted within a custom built enclosure. As a minimum, the enclosure shall have the following:

- Fully sealed (glass front)
- Lockable with keys or security screws (locks to be provided by UoM)
- Suitable to all temperatures
- Integrated air movement
- Mounting options: Wall mount, ceiling mount, stand-alone pedestal etc.
- Accommodate LCD screen and speakers within the enclosure
- To suit nominated FPD
- VESA mounting compatible or equivalent
- IP54 rated – dust and splash proof design
- Screen shall be accessible for servicing and maintenance.

18.21 INTERACTIVE FPD AND INTERACTIVE WHITEBOARDS

Interactive FPD and Interactive Whiteboards shall be minimum 55” diagonal, 16:9 aspect ratio and from a reputable manufacturer approved by Collaboration Endpoints.

The University recommends the use of interactive FPDs where possible. Interactive whiteboards shall only be used if 80” diagonal image, or larger is required. Interactive whiteboards must be supplied with an approved short-throw projector mounted on a manufacturer recommended ‘snorkel type’ arm / bracket. Contractors must ensure that the projector is positioned to minimise glare into the user’s eyes.

Interactive whiteboards and FPDs must be installed on walls and shall be mounted such that the top of the board is no higher than 2000AFFL.

Interactive whiteboards shall be directly cabled to University supplied computers.

18.22 VIDEO SWITCHING

The University transmits and switches the following video signals:

Type	Video Signal	Example
Analogue Video	XGA (1024x768) / WXGA (1280x768). Generally transmitted over RGBHV for cable runs longer than 3m	Legacy equipment
HD Video	HD1080 (1920 x 1080p)	Special requirements
Digital Video	HDMI / (EDID enabled)	Fixed computer, laptop input, document cameras, DVD, Blu-Ray, videoconferencing camera, videoconferencing codec etc.

All video signals shall be switched, scaled, transmitted and displayed in full HD resolution (1920x1080 pixels).

All new AV systems must be provided with provisions to support both digital video equipment (e.g. HDMI) as well as legacy analogue video equipment (Composite, VGA RGBHV etc.). All digital AV switching equipment must support EDID, CEC and HDCP protocols.

Video switching equipment must be provided with the ability to disable HDCP from any input, including HDMI computer sources, HDMI laptops and HDMI document cameras.

All source devices that provide HDCP content must also provide sufficient HDCP (KSV) keys to allow all display devices to display content.

18.23 SOUND REINFORCEMENT

Despite the growth in the use of visual and computer means of communication, verbal communication remains the single most important method of teaching and learning. Irrespective of the size of the space, maximum attention must be paid to optimising the acoustic properties of the space.

Amplification is required for all lecture theatres and should be considered for small presentation spaces of 35 seats or more.

Wherever amplification is installed, whether for presenter's voice or for electronic sound, provision for hearing aid induction loops and Echo360 should be considered.

Auxiliary inputs for sound presentation (audio-cassette, CD, iPod and computer audio), is always required for language teaching, and is required for all lecture theatres.

Typically, source audio shall be reproduced via dedicated front of house speakers and microphone audio shall be via ceiling mounted speakers. The hearing augmentation system and Echo360 system shall have combination of both source and microphone audio inputs.

18.23.1 Microphones

Wired and wireless microphones shall be used as required. Wired microphones shall be condenser boundary type microphones with a low profile and semi-cardioid pattern.

Wireless microphones using digital modulation shall operate on Band A 520-558MHz frequency range. Commissioning of wireless microphone systems shall be coordinated

with the existing range of frequencies in use in nearby spaces to ensure there is no interference. Alternative configurations to wireless microphones require approval from Collaboration Endpoints staff. Appropriate amplification shall be installed when quality sound reinforcement system is required.

Wherever microphone systems are installed, hearing augmentation systems must be installed.

18.25 HEARING AUGMENTATION SYSTEMS

The Contractor must provide Hearing Augmentation systems where there is an inbuilt amplification system, other than one used solely for emergency warnings, as per BCA requirements.

The type of Hearing Augmentation system must be determined with due consideration of the building environment, restrictions, interference and user requirements.

IR and RF hearing augmentation systems require approval from Collaboration Endpoints staff. Hearing induction loops are the preferred option for all projects.

A complete set of written test results must be provided with each system including a certificate of compliance as per AS1428.5-2010.

All hearing augmentation systems must be provided with a constant audio feed, that cannot be muted, from the AV system consisting of a mix of both source and microphone audio.

18.25.1 Hearing Induction Loop

The Contractor shall coordinate with the builder to install copper foil tape below the floor covering. Chasing of floor will not be feasible.

Hearing augmentation system shall provide 80% coverage of the space as per BCA, with low spill to outside areas unless otherwise specified.

As a minimum, the assistive hearing loop must meet the following minimum criteria:

- Field strength inside the area of use must be equal to 400mA/m plus/minus 3dB (tested with 125ms RMS measurement with 1kHz Sine wave)
- Total variation in signal across the frequency band 100Hz to 5kHz at 1kHz must be within 3dB anywhere in the loop area
- Background noise must be less than or equal to -32dB relative to 400mA/m.

Contractors shall specify an appropriate loop layout from the list below for rooms over 100m².

- Counter Loop - Typically used for counters and benches where one-to-one interaction is required.
- Perimeter Loop - Typically used in spaces where there are no spill issues and minimal metal loss.
- Single Array Loop - Typically used in fixed seating arrangements where it is known that users will not pass through the "null" zones during use.
- Cancellation Loop - Typically used for rooms located back-to-back where loop spill is reduced in one direction.
- Low Loss Phased Array - Typically used in spaces where metal loss occurs and there is a requirement to reduce spill into adjacent rooms.

- Ultra-low Spill Phased Array - Typically used in spaces where metal loss occurs and there is a requirement to reduce spill for confidentiality purposes.

The installer must seek specialist design advice from the manufacturer regarding the specific design of the system.

The Contractor must coordinate on site to determine the presence of existing adjacent hearing loop systems within the building.

The Contractor must conduct a site survey to undertake field strength measurements prior to designing the new hearing loop, to determine whether background interference is greater than, or equal to, -32dB relative to 400mA/m. The field strength measurements must be taken whilst adjacent hearing loop systems are in operation.

If an interfering system is discovered, the Contractor must advise the Project Manager and the Consultant and then proceed with the design of the hearing loop system.

The Contractor must submit results of background field strength measurements included with a manufacturer endorsed hearing loop technical design proposal. The measurement results and loop design proposal must be submitted to the Project Manager for approval prior to installation.

Where the manufacturer endorsed design includes the installation of copper foil tape below floor coverings (where chasing of floor is not be feasible), detailed technical drawings must be submitted for approval by Project Manager prior to installation.

The Contractor must engage the manufacturer of the hearing augmentation system to provide specialist design advice, site testing, technical data and design documentation from the system manufacturer for each space.

The manufacturer of the loop system, or their approved Australian distributor, must undertake the final system testing and provide the manufacturer certificate of compliance.

18.26 Infra-Red System

Infra-Red Hearing Augmentation system must include IR transmitters, antennas, IR receivers and room entrance and in room signage.

As a minimum, the IR Hearing Augmentation system must meet the following criteria:

- IR Hearing Augmentation must provide 95% coverage of the room as per the BCA
- Multiple transmitters may be required to ensure correct operation for all room configurations
- Transmitters must not be installed outside or in direct sunlight
- The number of receivers must correspond to the number of people the space accommodates to meet BCA regulations.
- Recharger and rechargeable batteries must be provided for each receiver supplied

Contractor must conduct a site survey and review line of sight restrictions and ambient light, prior to submitting a detailed design submission.

18.27 Radio Frequency (RF) System

Radio Frequency Modulated Hearing Augmentation system must include RF modulator, antennae, RF receivers and room entrance and in room signage.

As a minimum, the RF Hearing Augmentation system must meet the following criteria:

- RF Hearing Augmentation must provide 95% coverage of the room as per BCA

- The number of RF receivers must correspond to the number of people the space accommodates to meet BCA regulations
- Recharger and rechargeable batteries must be provide for each receiver supplied
- System must include all relevant licenses and fees

The Contractor must ensure that all RF transmitters and receivers do not interfere with existing equipment's frequency bandwidth or commercial frequency spectrum.

18.27 CONTROL SYSTEM

All teaching spaces provided with an audio visual system shall include a dedicated Extron control system fully programmed to control all audio visual devices. As a minimum each room shall be provided with a dedicated control system processor (Extron IP Link Control Processor or Integrated IP Link Processor) and fixed control interface (touch panel or keypad).

18.27.1 User interface

The University typically uses the following control interfaces:

Device	Model	Typical application
Wired Touch Panel	Extron TLP 1025	Lecture Theatres, Collaborative Spaces and some Seminar Rooms
Wireless touch panel	Requires approval from Collaboration Endpoints	Videoconferencing rooms and collaborative teaching spaces.
16 /8 button keypad	Extron MLC Plus Series	Seminar rooms and professional spaces

18.27.2 Device Integration

Typically, the following audio visual equipment shall be interfaced with the control system processor as follows:

Device	Control Interface
Video switch	RS232 or Ethernet
Audio DSP / Digital audio processor	RS232 or Ethernet
Audio amplifier	No control required
Video/data projector / FPD	RS232 or Ethernet
Lighting dimmers	RS232 or RS485. Interfaces to be provided by lighting contractor
Playback equipment	RS232
Document camera	RS232 or Ethernet
Wireless microphone system	Ethernet
Motorised projection screens	I/O or Relays or Ethernet

Motorised projector lift	I/O or Relays
--------------------------	---------------

Alternative configurations shall be approved in writing by Collaboration Endpoints.

18.27.3 Programming

Programming of control systems shall be coordinated with Collaboration Endpoints. The Control System programming shall be consistent with that of other teaching and professional spaces at The University of Melbourne where possible.

The Contractor shall organise workshops and submit samples of the touch panel and keypad layout to a Collaboration Endpoints representative to verify the layouts are correct prior to commissioning. A range of configurations and automation shall be available from the touch panel. Selecting a function from the touch panel shall operate all required equipment to perform that function e.g. selecting play on the Blu-Ray will switch the projector on, switch the AV switch to select Blu-Ray input and play the Blu-Ray.

Typical touch panel and keypad layouts are attached in Appendix A. Final touch panel layouts shall be developed on a project by project basis in conjunction with Collaboration Endpoints and User Groups.

The Contractor shall supply the fully working control system source codes on USB memory stick to the University on completion of the project. Software provided by the Contractor shall be procured and transferred in full compliance with the publisher's copyright, licensing and other requirements of ownership and use. License agreements shall be registered in the Principal's name.

The University shall retain full rights to all custom software and programming developed by the Contractor as part of the Project. This shall include, but not be limited to the right to use, reproduce and modify the software as reasonably required to operate the systems and to support their ongoing maintenance and development.

All IPCP Pro Series controllers shall be programmed in Global Scripser. Any deviation will require formal approval from Collaboration Endpoints.

18.27.4 Shut Down / Motion Sensor

Ceiling mounted motion sensors shall be provided for all spaces equipped with a control system. The control system shall be configured to automatically turn off all equipment when the motion sensor has not detected any movement for 2 hours, and the control interface has not been active within this period.

Additionally the control system shall be programmed to check status of the motion sensor at 11pm every night. If no motion has been detected, the AV system shall shut down all equipment. If motion has been detected, the system will repeat check every 2 hours.

18.27.5 Remote Management

All devices attached to an Extron control system with feed-back control (RS232, RS422, RS485 and TCP-IP) shall be able to be monitored and managed via the University of Melbourne's Remote Management platform, Extron GVE, via the University LAN. All AV control systems provided for the University must be enabled for remote management by Extron GVE. Contractors must coordinate with Collaboration Endpoints staff to integrate control systems for all spaces.

Existing spaces with AMX control systems must be upgraded to Extron control systems and integrated to the Extron GVE.

- As a minimum the remote management platform shall allow for real-time monitoring and problem notifications
- Source usage shall have the following labels:
 - Projector
 - FPD
 - Document Camera
 - Laptop Input – VGA
 - Laptop Input - HDMI
 - Computer
 - Set-top box
 - Aux Video Input
 - Wireless Microphone System(s) (monitor battery levels, frequency and name)
- Equipment/system status and hot list of equipment errors
- Flexible, intuitive interface that lets the user select how and what is monitored
- Professional help desk and monitoring
- Capacity to create the following web-based and/or log data reports:
 - Help requests
 - Room usage
 - Lamp hours
 - Both lamps for dual projection
 - Lamp fail message for all lamps
 - Source usage
 - System & device usage
- Monthly reports on all maintenance requirements

Consultants and Contractors shall confirm final requirements with Collaboration Endpoints on a project by project basis.

18.27.6 Remote Power Management

A networked power distribution unit (PDU) must be provided to all AV equipment racks to enable remote monitoring and management of devices. As a minimum the PDU must allow for the following functionality via a web-based RMS interface:

- Current metre per outlet
- Individual outlet power consumption
- Remote ON/OFF and reboot switching
- User defined group control (switched and un-switched devices)
- PDU must have minimum 8 ports, each rated at 10A at 240V AC.

18.27.8 IP Address & Asset Schedule

All devices connected to the network must be listed on the UOM Asset and IP Address Schedule and handed over to Collaboration Endpoints for ad hosting 2 weeks prior to commissioning AV system. The schedule will be shared by the Collaboration Endpoints

team via SharePoint. MAC addresses must be provided by AV contractor prior to IP addresses being allocated. The information must strictly follow the format provided (see figure below) and include the following details:

- Building Number
- Level
- Room Name/Type
- Room Number
- Device
- Make
- Model
- VLAN
- IP Address
- Subnet
- Default Gateway
- Host Name
- Outlet/Patch Number
- Switch/Port Number
- Port Req
- Sys Dev/No/ID
- IP Set
- Mac Address
- Serial

BLD Number	Building Name	Room Name/Type	Room Number	AV Integrator	Project Name/Number	Handover Date	Device Category	Manufacturer	Model Name	VLAN	IP Address	Subnet	Default Gateway	Host Name	Outlet/Patch Point	Switch/Port Number	Port Req	Sys Dev/No/ID	IP Set	Mac Address	Serial	Patch Lead Req	

Any decommissioned equipment needs to be documented and a spreadsheet sent to Collaboration Endpoints Team for instruction. Items will need to be delivered to either Collaboration Endpoints Team or the e-waste office.

18.28 CABLING

The Contractor shall ensure that all cabling is installed to avoid sources of electromagnetic interference. Cabling shall be run concealed in ceilings, floor ducts or in wall cavities, and shall be labelled to indicate source, destination and function. Surface ducts or conduits shall not be used.

Velcro ties are to be used for cable management. No plastic cable ties or “zip ties” shall be accepted.

The cables installed shall be as listed below:

Cable Type	Cable Description	Approved Manufacture
Video Projector Control	Low capacitance, 72 pF/m. 4 x stranded inner pairs with overall foil and drain screening only. Pair colours as per CAT5	Belden / Turnbull
Video Coaxial Cable	Coax, 1 coax, 20 AWG, stranded (26x34) TC - tinned copper conductors, EPDM - ethylene propylene diene monomer rubber insulation, conductive textile wrap, tinned copper Spiral Serve Shield, 72% shield coverage, neoprene jacket	Belden / Turnbull
Computer Video Cable	Digital video coax 5-way snake, miniature RG59/U, 23AWG, solid, soft PVC, 95% braiding, black	Belden / Turnbull
Digital Video Cable	HDMI cable, CTS category 2 version 1.3b compliant, verified for 1080p. 4 pair, 25 AWG stranded with drain wire, FR-PVC jacket. For continuous runs for no longer than 10m	Extron Ultra Series Extron Micro Series
Audio Cable	1 pair, 22 AWG (7/0.32) tinned copper, polyethylene insulation, twisted beldfoil shielded pair, 22 AWG stranded tinned copper drain wire, PVC jacket.	Belden / Turnbull
Speaker Cable	2 core speaker cable 14 AWG, stranded, 75 degree insulated, PVC jacket	Belden / Turnbull
Twisted pair	Category 6A shielded twisted pair. Data twist / media twist. Purple colour PVC jacket for AV services.	Siemon
Fibre	50/125 µm multi-mode fiber, OM3	Extron

Shielded twisted pair cabling installed for AV services must be fitted off on RJ45 block within lectern and RJ45 connection plates at the device location. Each location must be clearly labelled. Braided CAT6 leads must be used between connection plate/block and equipment.

Cabling that is to be routed within a motorised projector lift must be fitted off to a connection plate within the ceiling space at the mounting location. Shielded twisted pair cabling installed within a motorised projector lift must be a pre-terminated Alogic purple shielded Cat6a patch cable.

All other CAT6 leads must be terminated on R&M RJ45, IP67, FM45, rated jacks suited for industrial environments. Alternatives will not be accepted.

Shielded Cat6a cabling must be installed with a minimum bend radius of 50mm.

18.29 CONNECTION PLATES AND FLY-LEADS

Cabling points and engraved connection plates shall be installed as nominated on drawings. All connection plates shall be engraved to indicate the function for each nominated outlet. The style and finish of all connection plates shall be consistent and match the décor of the space.

Typically, all audio visual connections shall be terminated on Clipsal 2000 series connection plates. The following table details University standard connections:

Type	Video	Audio	Typical Installation location	Label
University supplied computer input	HDMI and appropriate adapter	3.5mm mini stereo jack for audio	Installed below lectern in dedicated shelf for computer	COMPUTER
Laptop input	HDMI		Installed above lectern	LAPTOP
Document Camera input	HDMI		Installed above lectern	DOC CAM
Lecture Capture System / Echo 360	HDMI	Phoenix connector for audio (combined microphone and source outputs from digital audio processor)	Installed in AV equipment rack	ECHO SYSTEM
Microphone		3-pin XLR Female	Installed on lecterns, media link, bio-boxes and floor boxes	MICROPHONE #

- denotes the number

Contractors shall submit connection plate samples for approval by Collaboration Endpoints.

Video adapters (mini DP, DP, USB-C etc.) must be approved by Collaboration Endpoints for suitability. Video adapters must be from the Liberty Digitalinx range and securely tethered to AV fly-leads using a Liberty DL-CL adapter ring clamp.

Contractors must provide all necessary fly-leads for all devices. Laptop fly-leads (HDMI) must comply with the following. Alternatives will not be accepted:

Fly-Lead Type	Description	Model	Length
HDMI	Designed to transmit HDMI digital video and audio signals, including 4K and UHD resolutions	Extron Micro series or Extron Ultra series	To suit application. Minimum 600mm

Wall mounted connection plates must be provided with suitably sized fly-leads. Leads must be neatly coiled within joinery or on hooks where joinery is not available. Contractor must ensure that fly-leads and cables do not pose any OH&S risk.

18.30 POWER AND DATA REQUIREMENTS

The following table details the typical electrical and data requirements to support AV systems. The final requirements shall be coordinated on a project by project basis with Services Engineer to match the system design.

Location	Electrical Requirements	Data Requirements	Typical AV Equipment
AV equipment racks	1 x 15 Amp captive outlet on dedicated circuit 1 x DGPO	4 x Data outlets	AV switching/ processing equipment, Echo360, videoconferencing codec, AV control system.
Lectern	4 x DGPO within joinery 1 x DGPO above joinery	3 x Data outlets within joinery 1 x Telephone outlet	Teacher's computer and monitor, local AV switch, AV touch panel, Blu-Ray player, document camera, laptop etc.
Teacher's desk	4 x DGPO within joinery 1 x DGPO above joinery	4 x Data outlets within joinery	Teacher's computer and monitor, local AV switch / distribution amplifier, AV touch panel, Blu-Ray player, document camera, laptop etc.
FPD, video/data projector location (standard installation)	1 x DGPO	2 x Data	Projector/ FPD, future AV receiver etc.
FPD, video/data projector location (motorised lift/mount)	2 x DGPO	2 x Data	Motorised lift, projector/ FPD, future AV receiver etc.
Motorised projection screen	1 x GPO	1 x data	Motorised projection screen

The requirement or use of a dedicated AV Network Switch in any project shall be discussed and approved with the Collaborations Endpoints Team prior to inclusion and where required the University's Network Operations Team. Where a dedicated switch is used, a single UoM LAN point must not have any more than 9 MAC addresses associated.

There are four key UoM Network configuration classifications for AV Projects at the University that are used/referenced in a given AV project.

- LS VLAN/1300 – Dedicated AV VLAN Network (most if not all AV equipment)
- MITS/1400 – Digital Signage and devices requiring UoM User authentication
- Staff Mobility/1100 – Fixed IT Computing
- VoiP – In-Room Resource Phone

*ports are configured for PoE (802.3)

18.31 LECTERN / TEACHER'S DESK JOINERY

University standard lecterns shall be used in all lecture theatres and large teaching spaces. Smaller classrooms and seminar rooms may use standard mini-lectern or teacher's desk, depending on the amount of AV equipment.

The standard lecterns provide an area on top of the bench for presenter's notes/laptop, microphone(s), touch panel, PC monitor, document camera(s), wireless microphone charger(s) and input connections. It also includes sufficient space below the bench for University PC, and other AV switching equipment.

The standard lectern design can be modified to match the aesthetics to a limited extent. However changes to the design must not change the structural frame of the lectern and must be approved by Collaboration Endpoints staff prior to installation.

A floor duct or trench is required to carry electrical and AV wiring to the lectern. The duct must be compartmented to provide separation between services. Services must be terminated in floor boxes for mobile lecterns.

All AV equipment must be securely installed in an equipment rack within the lectern. Ventilation provided within the lectern must not be obstructed or covered. The lectern doors and access panels shall be secured with University standard TEC keys. Contractor must ensure that lecterns can be raised and lowered unimpaired.

A telephone shall be fixed securely in a position on the lectern where easily seen and usable without bending and where it does not interfere with the main flat surface of the lectern. Microphones must be fixed to lectern with tamperproof screws. Design and construction of the unit shall provide a well damped, rigid structure without excessive resonance.

Final joinery details shall be coordinated and approved by Collaboration Endpoints. UOM standard lectern designs are included in Appendix D.

18.32 AUDIO VISUAL EQUIPMENT STORAGE

The following AV equipment storage is required:

- AV equipment cupboard for ready access by presenters using the "LEC key", recessed completely into a wall at the front of the theatre, and utilising the international 19" rack mounting standard and readily accessible to service staff.

- AV systems and AV equipment racks shall be separately keyed under the "TEC key" for access by maintenance and technical staff.
- A dimmer cupboard usually adjacent to the switchboard outside the theatre, and never physically adjacent to the AV systems rack.

18.32.1 Ventilation

Ventilation shall be provided to maintain the temperature of all AV equipment within the manufacturer's specifications. Ventilation requirements shall be determined by the Services consultant. Ventilation methods may include:

- Air inlets at low level and air outlets at high level must be provided to provide airflow through the rack, lectern, joinery or other relevant enclosure requiring ventilation.
- Ventilation slots or grilles shall be selected following consultation with the Architect.
- Natural convection or fan driven ventilation shall be provided to accommodate the heat load of the AV equipment requiring ventilation.
- Lighting dimmer cupboards will also require ventilation to maintain temperatures within the range of the dimmer manufacturer's specification.

18.32.2 Power Supply

240V mains power on dedicated AV circuits are required for AV equipment, generally as follows:

- 15 Amp captive outlets for AV racks fitted with internal power rails.
- 10 Amp single or double GPOs for AV equipment

Specific requirements for each project are to be determined by the Services Consultant.

18.32.3 Dimensions of Equipment Cupboards

The internal cupboard enclosure usually provides a mounting surface for audio visual cable looms and ducts, power distribution conduits etc.

Adequate clearance must be provided for these services plus the actual metal rack frame. At least 150mm clear space is required behind the equipment rack frame, inside the cupboard.

Minimum internal dimensions for an equipment rack cupboard are 750mm x 650mm (depth x width).

Cupboard height varies with the size of the rack installation; however two common formats do occur:

- Typically the height is around 2100mm, allowing for installation of a full height (45RU) equipment rack.
- In the second case, the cupboard is much lower, usually no more than one metre high, often built with a bench top for use by presenters. In these cases the cupboard needs to be twice as wide, to allow for installation of two half height rack frames.

18.32.4 Access to Equipment

The rack shall be mounted on wheels to allow rack removal for service and the lecture theatre floor and the rack cupboard floor must be continuous. If the equipment is housed in two racks, there must be sufficient length of cable connection between the two racks to allow one of the two racks to be brought out alone.

All rack cupboard doors are fitted with the TEC key lock for technician access to remove/repair equipment and LEC key lock for user access to operate equipment.

18.32.5 Cantilevered Cupboards and Bio-Boxes

Projector cabinets and such shall not be cantilevered out from walls. This creates a safety hazard in terms of people knocking their heads, and in terms of people hanging on them. All cabinet work shall be taken down to the floor, not supported from walls.

18.32.6 Lighting Inside Cupboards

Light sources shall be located in a shielded position inside the projector cabinets or cupboards which activates when the access door is opened.

Rear projection rooms require adequate shielded lighting for operators.

All equipment racks require adequate internal lighting for technical staff.

18.32.7 Dimensions and Location of Projection Room

Sufficient height is required to clear audience heads and sufficient room is required for a bench for video/data projectors.

18.32.8 Acoustic Isolation

The Dimmer cupboard and rear projection room must be acoustically insulated to prevent dimmer or projector noise from disturbing lectures.

18.32.9 Doors

The front door of a recessed cupboard has conventional hinges and with the door closed, the cupboard door face is flush with the wall.

18.32.10 AV Equipment Rack

The AV Equipment Rack shall house all AV switching and processing equipment and thus be appropriately sized. The 19" AV equipment racks shall meet the following specifications:

- 540mm wide x 540mm deep
- Sized to accommodate equipment plus 20% spare capacity in AV cupboards
- Complete with 19" patch panels for termination of AV cabling
- Vertical and horizontal patch-lead management
- 1 x 8 way vertical power strip fitted with captive plug tops
- 1 x 8 way vertical power strip for switched power, connected to output of the power controller
- Power surge protection
- 2 x 100mm cable trays fitted to the inside of the equipment rack
- Fix the power controller to one of the cable trays
- Install manual reset button to be configured with power controller
- Allow for security panels as shown on the drawings
- Lockable doors and side panels
- Heavy duty castors to allow rack to be pulled out of cupboard for servicing.
- Shall be of reputable local manufacture

The colour finish and labelling of the cabinets shall be approved by Collaboration Endpoints.

Seminar rooms, Professional spaces and other small teaching spaces shall be provided with 19" rack strips installed within teacher's desk, in place of dedicated equipment racks. The size of rack strips shall be selected to accommodate equipment.

Detailed shop drawings shall be submitted for approval prior to manufacture, indicating the layout and labelling of the patch panels.

18.33 LECTURE CAPTURE

The University of Melbourne Lecture Capture System is a central recording system that records and distributes audio and visual content from lecture theatres and other teaching spaces. The audio visual content is captured, encoded, stored on a central server and delivered over the University network via dedicated portal and a network connection to a dedicated VLAN.

The Lecture Capture System requires a dedicated video input from the theatre video switch and a dedicated audio feed from the theatre digital audio processor connected to the balanced audio inputs.

The audio feed shall be a combined mix of both microphone and source audio inputs terminated into the stereo phoenix connectors. PA / program audio touch panel controls shall not affect the level to the capture appliance. It will have a constant audio feed.

The video input to the Lecture Capture is HDMI and is split from the primary display (left projector in a dual projection room), however in some spaces a HDMI video output is also provided from a camera installed within the theatre. Video feed must be 720p or 1080p.

The touch panel control system installed within the theatre shall include a dedicated page for Lecture Capture Systems to monitor, pause and stop recordings (see appendix A). Control system must post-fade/mute audio feed when recording is paused or stopped. System shall have remote powering on/off capabilities for new devices.

The Echo 360 System must be installed securely within the AV equipment rack.

18.34 DIGITAL SIGNAGE

Digital signage systems provided within the University shall be network enabled and be integrated with the centrally managed Samsung digital signage platform.

Each project will be required to determine the following:

- Number and type of displays and player hardware
- Number of content administrators / authors
- Content management policy
- Network storage

Design and deployment of all digital signage systems must be coordinated with Collaboration Endpoints.

Digital Signage commissioning sheet to be sent to Collaboration Endpoints once screen is installed.

18.35 OVERFLOW

Selected theatres shall be provided with over flow displays (FPDs / projection systems) in the foyer area outside. Overflow displays are used in special circumstances when the theatre does not have enough seating capacity within the venue.

Nominated theatres must be provided with PTZ camera(s) within the theatre that can capture and display the presenter to the overflow display. Additionally, a dedicated feed from the video matrix switch must also be provided so that the overflow display can replicate the same content shown on the primary projection system within the theatre.

The size of the overflow display and installation locations shall be confirmed with Collaboration Endpoints.

18.36 MEDIALINKS

Selected theatres shall be provided with media outlets to allow external parties, such as news services, to connect for recording purposes. Additionally, audio visual links shall also be provided to adjacent theatres to allow media and other external parties to view lectures.

The specific number of connections and the number of links required shall be confirmed with Collaboration Endpoints.

18.37 AV Links

The following links, if available, must be transmitted to adjacent theatres:

- HDMI video content from primary projector
- Video from PTZ camera
- Combined audio from digital audio processor. Audio shall be a mix of source and microphone.

18.38 Media Connection

As a minimum, media outlet shall consist of the following connections:

- 4 x Male XLR connections for microphones
- Female XLR connections for microphones
- BNC connections for video if required

18.37 LIGHTING

18.37.1 Lighting Levels

Lighting levels within teachings spaces must comply with the minimum requirements as nominated in the Property Services standards.

18.37.2 Integration

AV Contractor shall coordinate with electrical contractors to integrate lighting systems with the AV control system. The electrical contractor shall be responsible for providing and installing lighting dimmers along with an RS232/RS485 interface.

As a minimum the AV contractor shall provide the following lighting pre-sets:

Pre-set	Description
OFF	All lights turned off (excluding lectern light, emergency lights and aisle lighting)
ON	All lights on

AV	Stage lighting directed at the front of the theatre is turned off to reduce any glare on the projection surface. Theatre lighting reduced to 40%
Presentation	Stage light turned on. Theatre lights reduced to 40%

Final lighting requirements and configurations shall be coordinated with Collaboration Endpoints and User Groups.

The University preferred lighting dimmer system is Philips Dynalite.

18.38 VIDEOCONFERENCING SYSTEM

The University currently deploys videoconferencing systems to selected teaching and professional spaces. Each teaching space shall be designed in consultation with Collaboration Endpoints to meet the User Groups requirements. The AV Consultant shall consider and coordinate the following aspects of the room:

- Lighting
- Lighting control
- Furniture selection
- Interior design (wall colour, carpets, curtains etc.)
- Acoustics
- Wireless network coverage
- Wired network bandwidth and capacity (to be coordinated with Information Technology Services)

18.38.1 Codec Based Systems

Codec based systems are no longer deployed. Liaise with Collaboration Endpoints staff to confirm requirements.

18.38.2 Web-conferencing

Small meeting rooms, huddle spaces and selected teaching spaces may be provided with a web-conferencing system that is configured to operate via software pre-loaded onto a resident PC. Web-conferencing systems provided to the University must comply with the following:

- Web-conferencing software must be Zoom or Skype for Business/ MS Teams cloud based application linked to the University's existing account/subscription.
- IP enabled and configured to operate over the University LAN
- H.323/SIP compliant with provision to connect to multiple endpoints
- Support H.264, H.239, H.235, and G.722 protocols
- Capacity to support content collaboration for concurrent video and content streams.
- Full control via GUI software
- USB camera and microphone(s)
- Huddle and Meeting spaces up to 12 people will require cameras that are Zoom / Skype for Business / MS Teams compatible, controlled via software.

18.39 HANDOVER

Practical completion will be granted when the following minimum requirements have been fulfilled by the AV Contractor:

- Completed IP Data Sheet has been submitted to Collaboration Endpoints
- System has been tested and commissioned
- System has been inspected by Collaboration Endpoints and the AV Consultant and has been deemed to be operational and practically complete
- Serial numbers of all new equipment has been submitted to Collaboration Endpoints
- All documentation has been approved by the AV Consultant and submitted to Collaboration Endpoints
- All control system source codes have been handed over to Collaboration Endpoints and become the intellectual property of the University
- Interface testing to the Extron GVE system has been successfully completed
- All training has been completed
- All accessories, software, fly-leads and remote controls have been handed over to Collaboration Endpoints. All packages of information handed over to Collaboration Endpoints shall be scheduled in a transmittal, copied to the Project Services project manager and AV Consultant
- Notice of Practical Completion issued by AV Consultant

The issuance of a Notice of Practical Completion by the AV Consultant is contingent upon the rectification of any installation defects by the AV Contractor. Installation defects are classified as follows:

Severity	Characteristics	Examples
Critical	Space is unable to be used, no workaround exists	Network not active for computers Displays not working User interface not working OHS related issues
Major	Functionality is limited or contains significant performance issues. A workaround can be temporarily implemented to allow use of space.	Some sources not working Lighting pre-sets not finalized No source audio present Some components not supplied Performance issue may include poor audio quality, distorted video signal

Minor	Space is usable though some known errors are present, and some functionality may be limited. Some aspects of space may not conform to specification and applicable standards.	Fly-lead missing / adapters not supplied Equipment not secured, such as touch panel Hook for fly leads not present EDID not set correctly Display not aligned AV equipment is not on network for monitoring and remote support
Trivial	Issues that do not impact on useability of space	Grammatical errors on user interface Errors in document submissions such as user guides and as-built drawings

The priority of these installation defects are further categorised as follows:

Priority	Characteristics	Examples
Immediate	Defect to be resolved asap to be able to proceed with delivery of space	OHS Issues Critical Defects
Urgent	Defects to be resolved prior to high, normal and low defects	Major Defects
High	Should be fixed as soon as possible	Major and Minor Defects
Normal	To be resolved once higher priority defects have been attended to	Minor Defects
Low	Fixing may be deferred until a later period	Trivial Defects

18.40 DOCUMENTATION AND SUBMISSIONS

As a minimum the following documentation shall be submitted to Collaboration Endpoints:

- Installation manuals with full description of the installed system including maintenance requirements
- Operational manual with clear and concise description on how to operate the AV system
- Quick reference guide. A one-page summary, briefly describing the basic operation of the AV system for each room using a UoM provided template.
- Equipment manuals of all equipment installed
- Details of equipment manufacturers and distributors

- As-built drawings including the following:
 - Audio schematic
 - Video schematic
 - Control system schematic
 - Floor plans, elevations and sections of teaching space indicating equipment locations, mounting heights and installation detail, including hearing loop layout if present.
 - Cabling schedule
- Serial numbers and MAC addresses of all equipment provided
- Commissioning test results (See Appendix C for template)

Contractors must provide an electronic copy of all documentation in PDF format via email or shared via cloud based platform.

18.41 TRAINING

Contractors shall allow for a minimum of 2 training sessions for each teaching space. An operator training course and a technical training course shall be provided.

The operator training course shall include but not be limited to training of the following systems:

- Basic operator principles of the system
- Operating principles of video, audio and control system equipment and functions
- Practical training in the operation of each function of the control system
- Equipment locations and operation

The technical training course shall include, but not be limited to, training of the following systems:

- Overall principles of operation of the AV System with specific emphasis on the installed system
- Basic operator principles of the system
- Operating principles of video, audio and control system equipment
- Practical training in the operation of each function of the control system
- Equipment locations and operation
- Maintenance and fault finding procedures
- Fault simulation for practical training in fault finding procedures

Training is to be formally structured. A training program, syllabus and personnel assessment format shall be provided prior to commissioning for approval. Training shall be provided prior to the issue of final certificate of the works.

Additional training courses may be requested by Collaboration Endpoints or the User Group.

APPENDIX A STANDARD TOUCH PANEL AND KEYPAD LAYOUTS

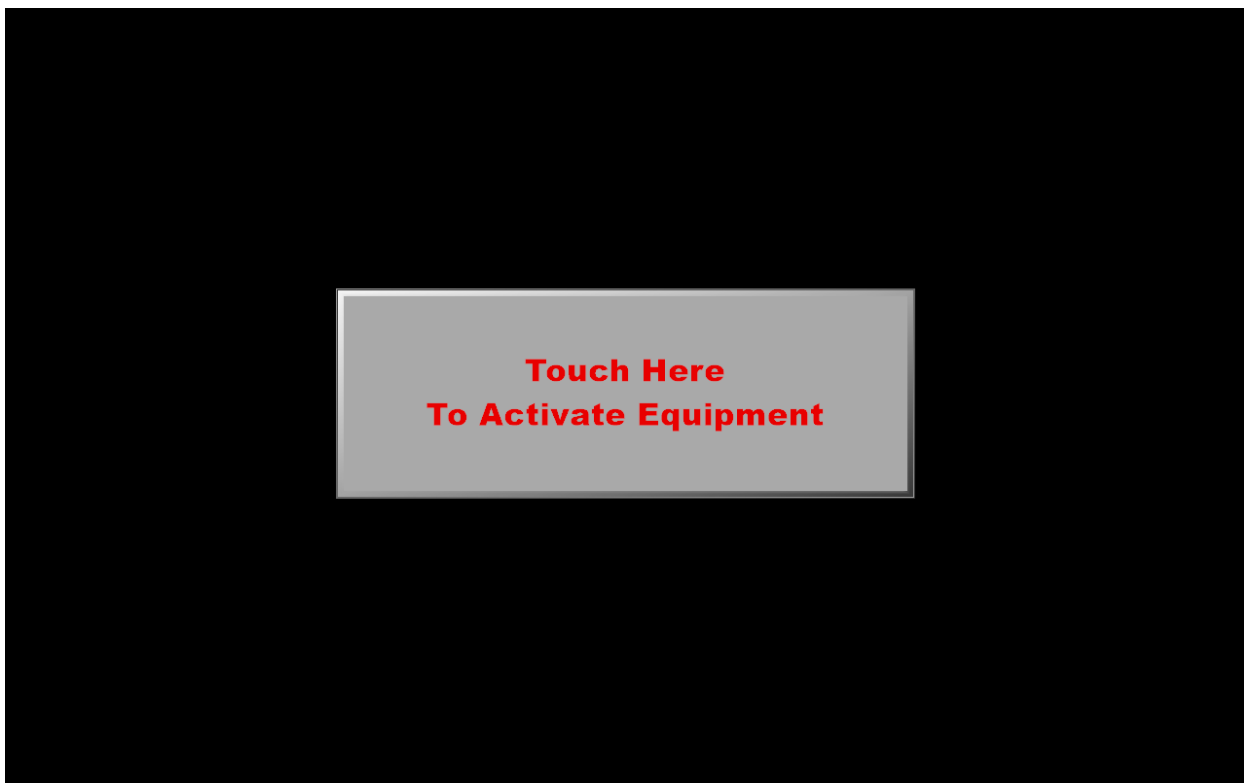

Start Up

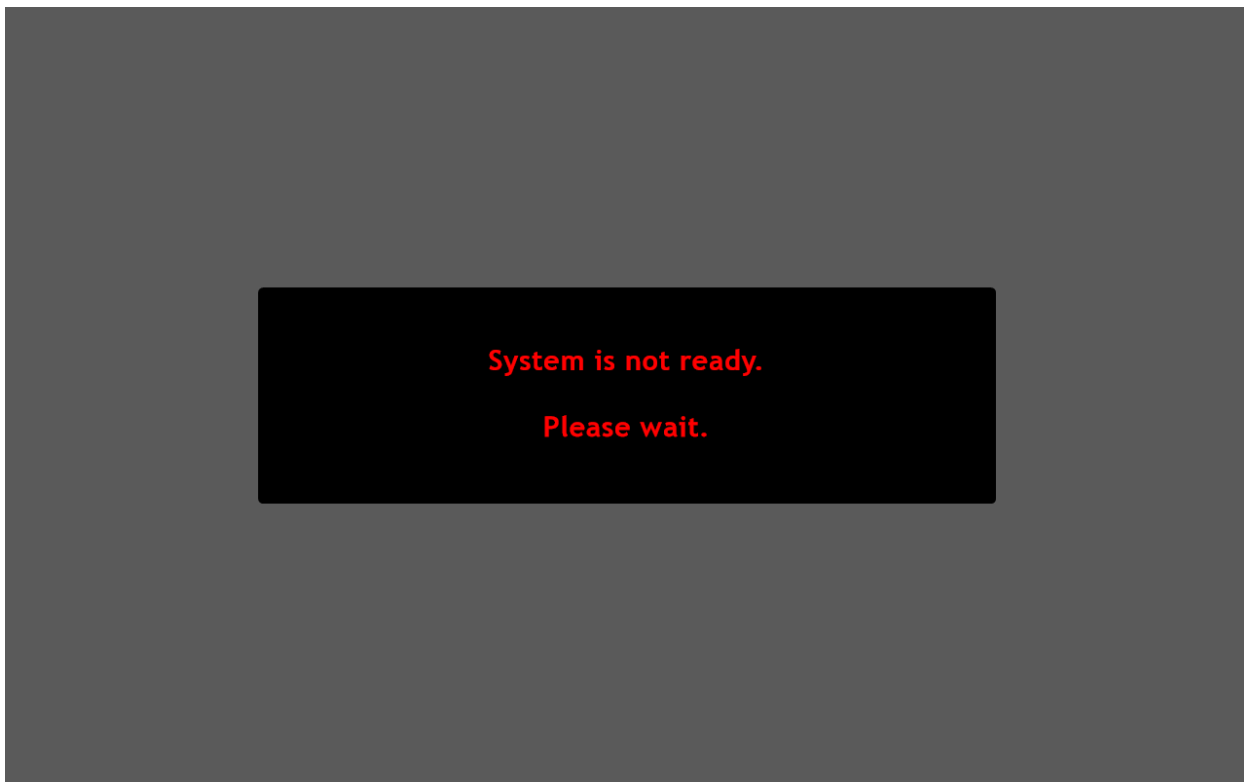

System Waiting

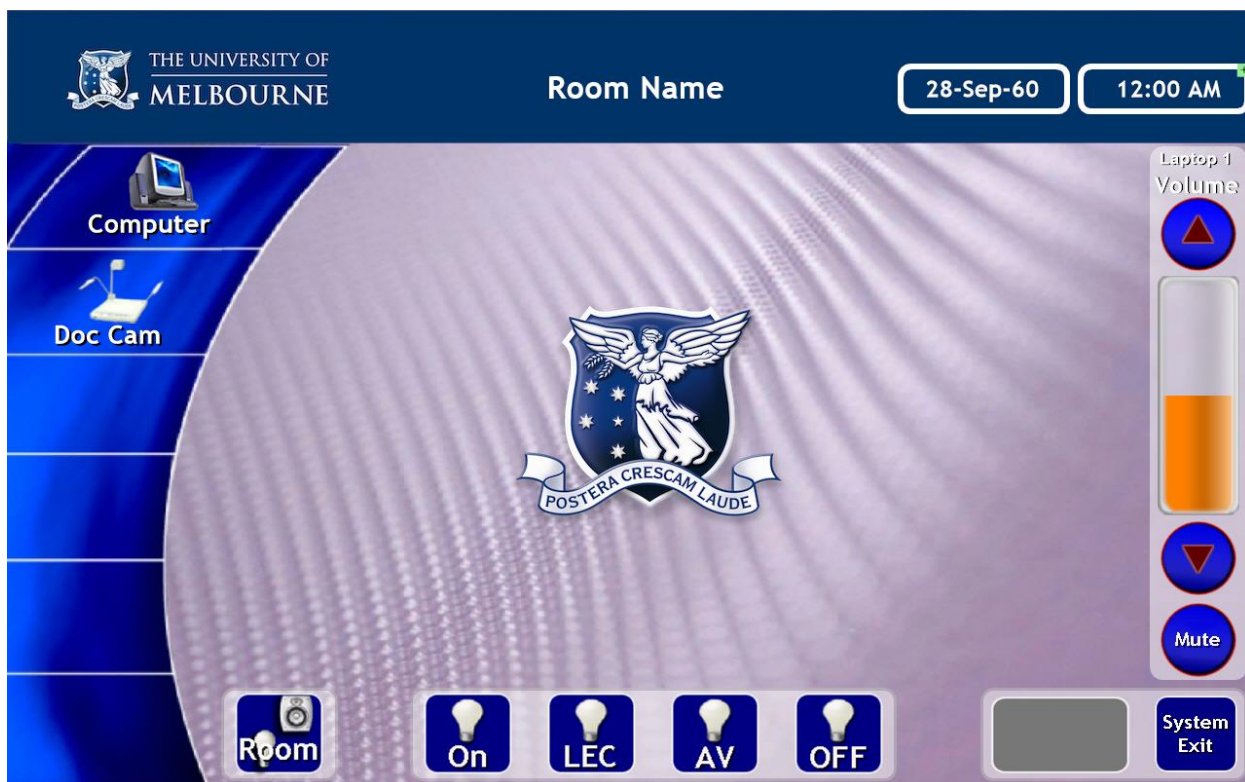

Main Page

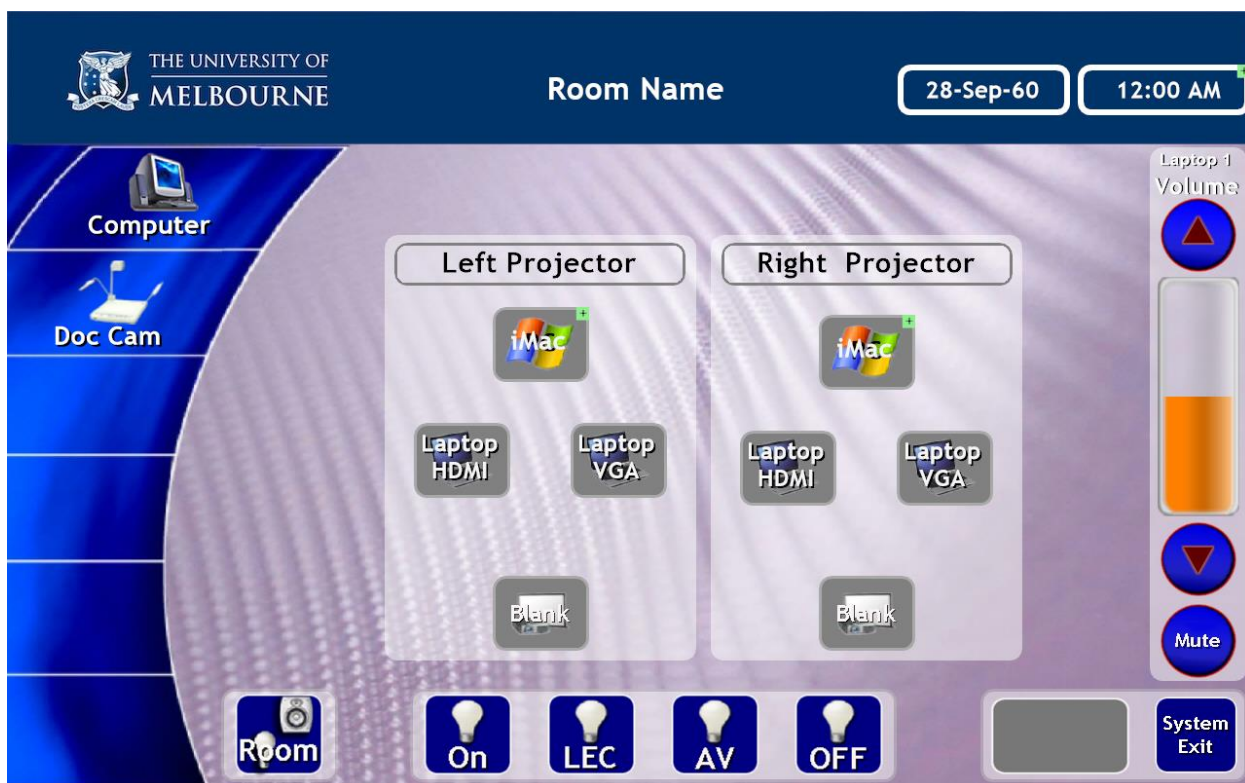

Computer



Document Camera

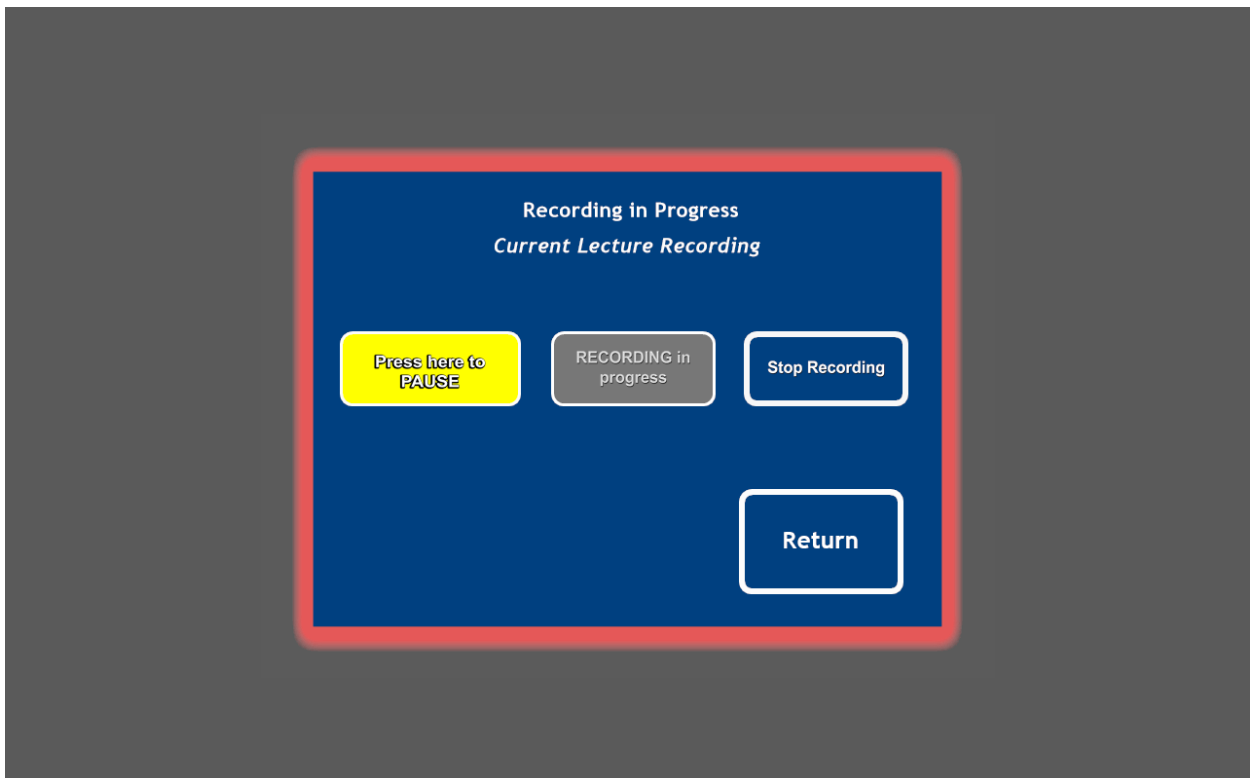

Lecture Recording

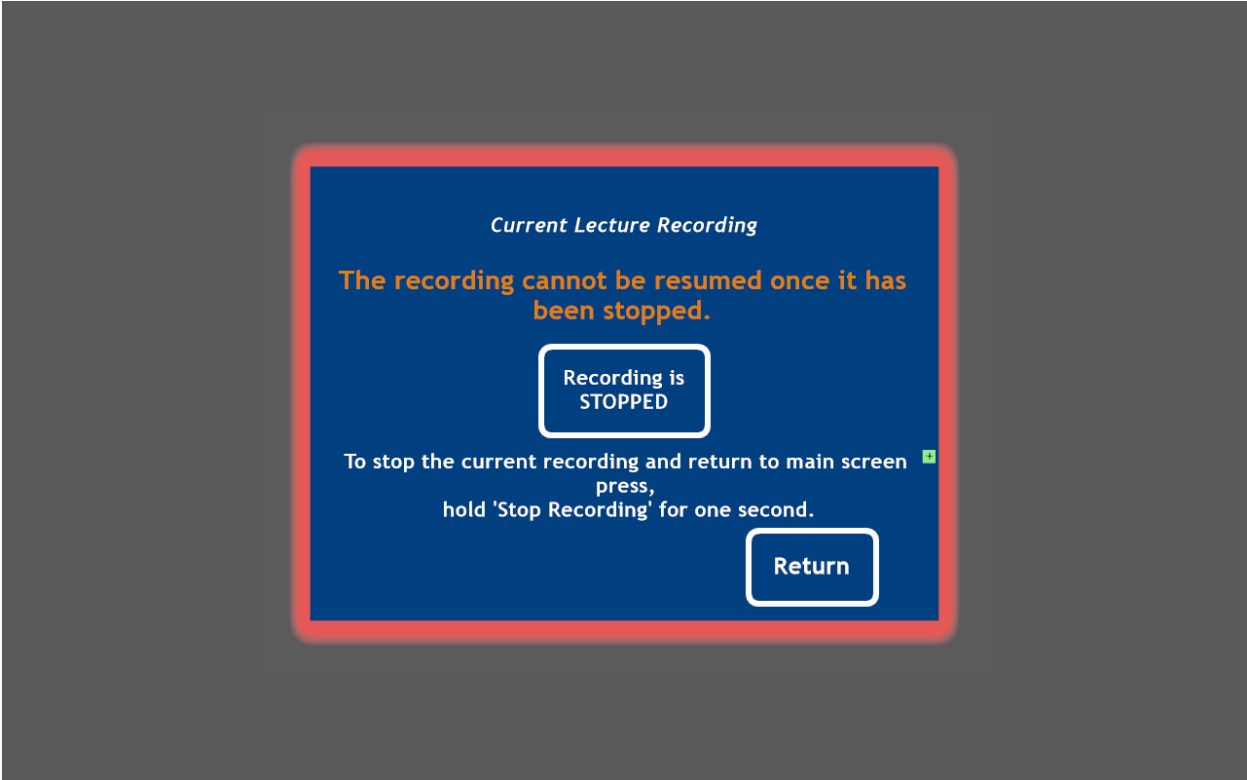

Lecture Recording stop

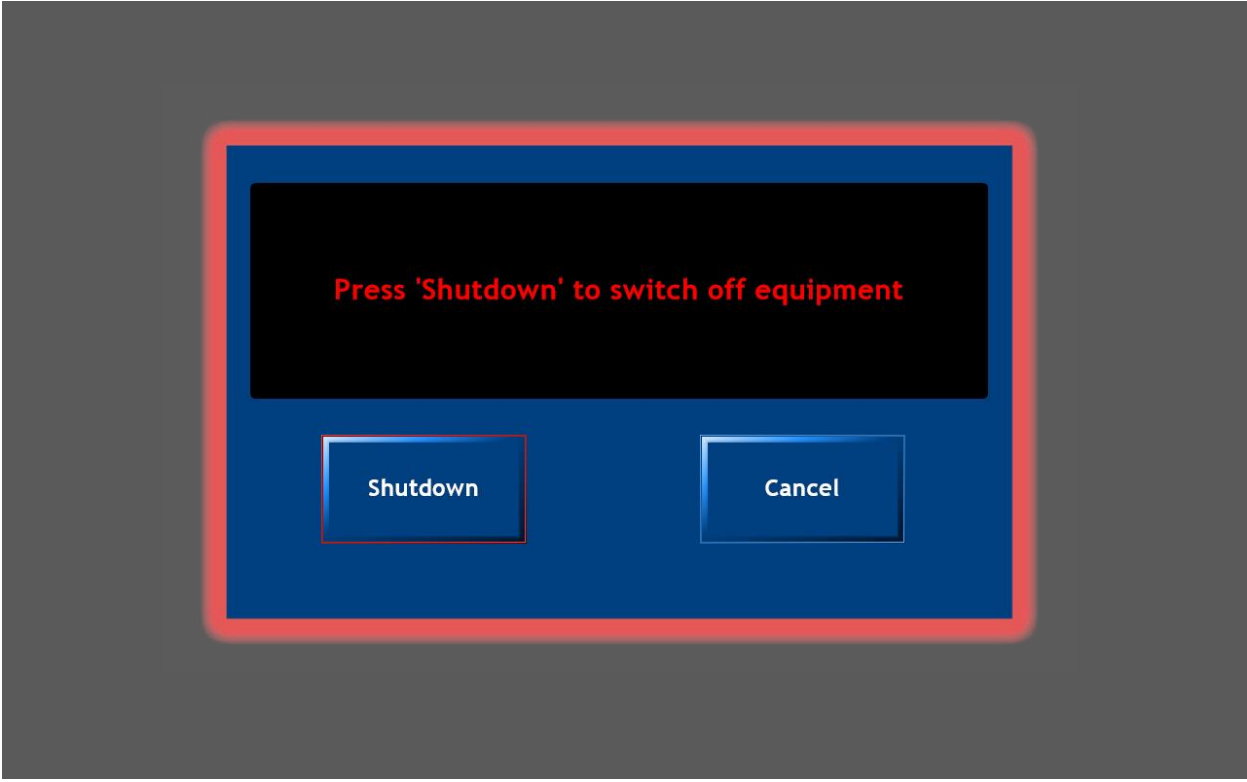

System Shutdown

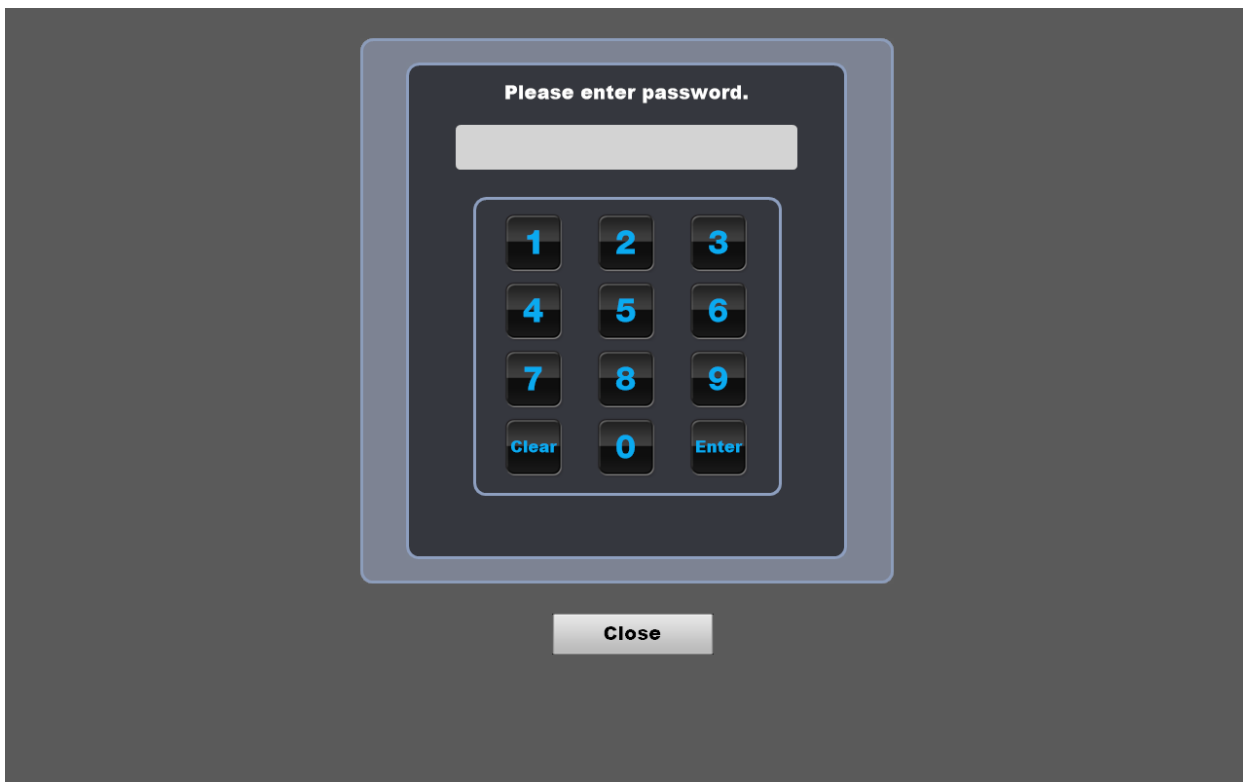

Password for technical page access

The image displays a technical dashboard with several panels:

- Displays:** A table with columns: GVE Name, Connection (Offline), Hours, Fault, and Lift (Up, Down buttons).
- Other Devices:** A table with columns: GVE Name, Connection, GVE Name, Connection, GVE Name, Connection.
- Radio Mics:** A table with columns: GVE/TX Name, Connection (Offline), Battery, Frequency, Squelch.
- Test Theatre name:** A panel with fields for GVE Name (????????), Appliance (Test Theatre name), and Title (This is test text). It includes buttons for Pause, Resume, and Recording System Offline. The device state is Inactive.
- Motion Detectors:** A panel with four status indicators (circles) and a Timeout Period of 600 minutes.
- System Info:** Sys Boot: 200 days 23h:42m:50s, Prog Start: 2018-12-30 23:55:44.
- Return:** A button at the bottom right.

Technical Page



*Button labels will differ on a project by project basis. Contractors must confirm labels with Consultant prior to commissioning

APPENDIX B APPROVED AV EQUIPMENT MANUFACTURERS

EQUIPMENT / DEVICE	MANUFACTURER	MODEL
Projector	Sony	VPLFHZ58 or to meet project requirements
Large Venue Projector	Sony Panasonic	VPLFHZ700 (to meet project requirements)
Interactive Short Throw Projector		Consult with Collaboration Endpoints
Interactive Flat Panel Display	NEC Hitachi Samsung Flip	(to meet project requirements)
Flat Panel Displays	NEC Panasonic Samsung Sony	(to meet project requirements)
FOH Speaker	Bose JBL	Panaray 402 Control 23, Control 25, Control 28
Ceiling Speaker	JBL	Control 24CT, Control 26CT
Pendant Speaker	JBL	Control 60, Control 67, Control 65
PTZ Camera	Sony	SRG300, SRG120DU
Document Camera	Wolf Vision	WOLVZ8L4, WOLVZ3
Wireless Presentation System		Consult with Collaboration Endpoints
Boundary Microphone	Beyerdynamic	PMC65VC
Wireless Handheld Microphone	Sennheiser	SL Handheld Set DW-3-AU R
Wireless Lapel Microphone	Sennheiser	SL Lavalier Set DW-3-AU R
Wireless Microphone Charging Bay	Sennheiser	CHG 2 or CHG 4N
Ceiling Microphone	Shure	MXA910 MX202
AV Switch	Extron	(to meet project requirements)
Twisted Pair Extenders	Extron	(to meet project requirements)

EQUIPMENT / DEVICE	MANUFACTURER	MODEL
AV Control System Processor	Extron	(to meet project requirements)
Touch Panel	Extron	TLP Pro series – 10”
Wireless Touch Panel		Consult with Collaboration Endpoints
Keypad	Extron	MLC Plus Series
Digital Audio Processing	Biamp Extron Shure	Nexia, AudiaFlex, Tesira DMP Series P300, ANIUSB when using MXA910
VC Codec	-	(confirm with LSS)
Audio Amplifier	Yamaha Extron Crown	P2500 MPA152, XPA1002, XPA2001, XPA2002 XLI series, XLS series
Hearing Induction Loop	Ampetronics	(to meet project requirements)
IR Hearing Systems	Sennheiser	(to meet project requirements)
Digital Signage	Samsung	Magic Info (Consult with Collaboration Endpoints)
AV Network Switch	Netgear	GS108* (Consult with Collaboration Endpoints)
Projector Mounts	Ultralift	Spyder UOM Custom
LCD Mounts	Ultralift Vogel	(to meet project requirements)
Projector Lift	Ultralift	UOM Custom Unilift 2 (to meet project requirements)
Projection Screen	Screen Technics	(to meet project requirements)
Racks (Frame)	Elgee	ZipRacks
Racks (Cabinet)	MFB	2005 Series
USB Cameras	Logitech	HD Pro Webcam C930, MeetUp, Pro PTZ 2
USB Microphone	ClearOne	Chat 150 / Chat Attach
USB Scaling Bridge	Extron	MediaPort 200
Lectern	Lectern Hub	UOM Custom
Room Booking Panel		(Consult with Collaboration Endpoints)

APPENDIX C AV COMMISSIONING SHEET TEMPLATE

University of Melbourne / Collaboration Endpoints

AV Commissioning Template



Project Details

UOM Project BR Reference:

Project Name:
Building Address:
Room No./Space:
AV Contractor
AV Contractor's Project Manager:
AV Contractor's Commissioning Manager:
Date of Commissioning:

Notes:

Input Devices

Item		Tested	Comments / Notes
Installed PC / iMac	Audio	<input type="checkbox"/>	
	Video	<input type="checkbox"/>	
Laptop Connection Plate	Audio	<input type="checkbox"/>	
	Video	<input type="checkbox"/>	
DVD/ Blu-Ray Player	Audio	<input type="checkbox"/>	
	Video	<input type="checkbox"/>	
Document Camera	Video	<input type="checkbox"/>	

Item		Tested	Comments / Notes
Video Conferencing System	Video	<input type="checkbox"/>	
	Audio	<input type="checkbox"/>	
	AEC	<input type="checkbox"/>	
Boundary Microphone	Audio	<input type="checkbox"/>	
Wireless handheld Mic	Audio	<input type="checkbox"/>	
Wireless Lapel Mic	Audio	<input type="checkbox"/>	

Output Devices

Item		Tested	Comments / Notes
Video/Data Projector	Video	<input type="checkbox"/>	
LCD Panel	Audio	<input type="checkbox"/>	
	Video	<input type="checkbox"/>	
Echo System	Audio	<input type="checkbox"/>	
	Video	<input type="checkbox"/>	
Front of House Speaker	Audio	<input type="checkbox"/>	
Ceiling Speakers	Audio	<input type="checkbox"/>	
Hearing Augmentation Sys.	Audio	<input type="checkbox"/>	

Hearing induction loop system compliance certificate provided as per AS1428.5-2010 Yes/No

Control System

Item		Tested	Comments / Notes
AV Switching	Audio	<input type="checkbox"/>	
	Video	<input type="checkbox"/>	
Audio DSP	Levels	<input type="checkbox"/>	
	Quality	<input type="checkbox"/>	
DVD/Blu-Ray Player	Audio	<input type="checkbox"/>	

Item		Tested	Comments / Notes
	Video	<input type="checkbox"/>	
	Play	<input type="checkbox"/>	
	Stop	<input type="checkbox"/>	
	Fwd/Rev	<input type="checkbox"/>	
	Next/Prev	<input type="checkbox"/>	
	Menu	<input type="checkbox"/>	
	Navigation	<input type="checkbox"/>	
	Enter	<input type="checkbox"/>	
	Vol +/-	<input type="checkbox"/>	
Projector Lift	Up/Down	<input type="checkbox"/>	
Lighting	ON	<input type="checkbox"/>	
	OFF	<input type="checkbox"/>	
	AV	<input type="checkbox"/>	
	Pres	<input type="checkbox"/>	
Control System	Shutdown	<input type="checkbox"/>	
	Reset	<input type="checkbox"/>	
	Helpdesk	<input type="checkbox"/>	
	RMS	<input type="checkbox"/>	
Touch Panel	Layout	<input type="checkbox"/>	
	Icons	<input type="checkbox"/>	
	Labels	<input type="checkbox"/>	

Other

Item	Tested	Comments / Notes
(Contractor to specify)	<input type="checkbox"/>	
(Contractor to specify)	<input type="checkbox"/>	
(Contractor to specify)	<input type="checkbox"/>	

APPENDIX E UOM STANDARD LECTERN DESIGN

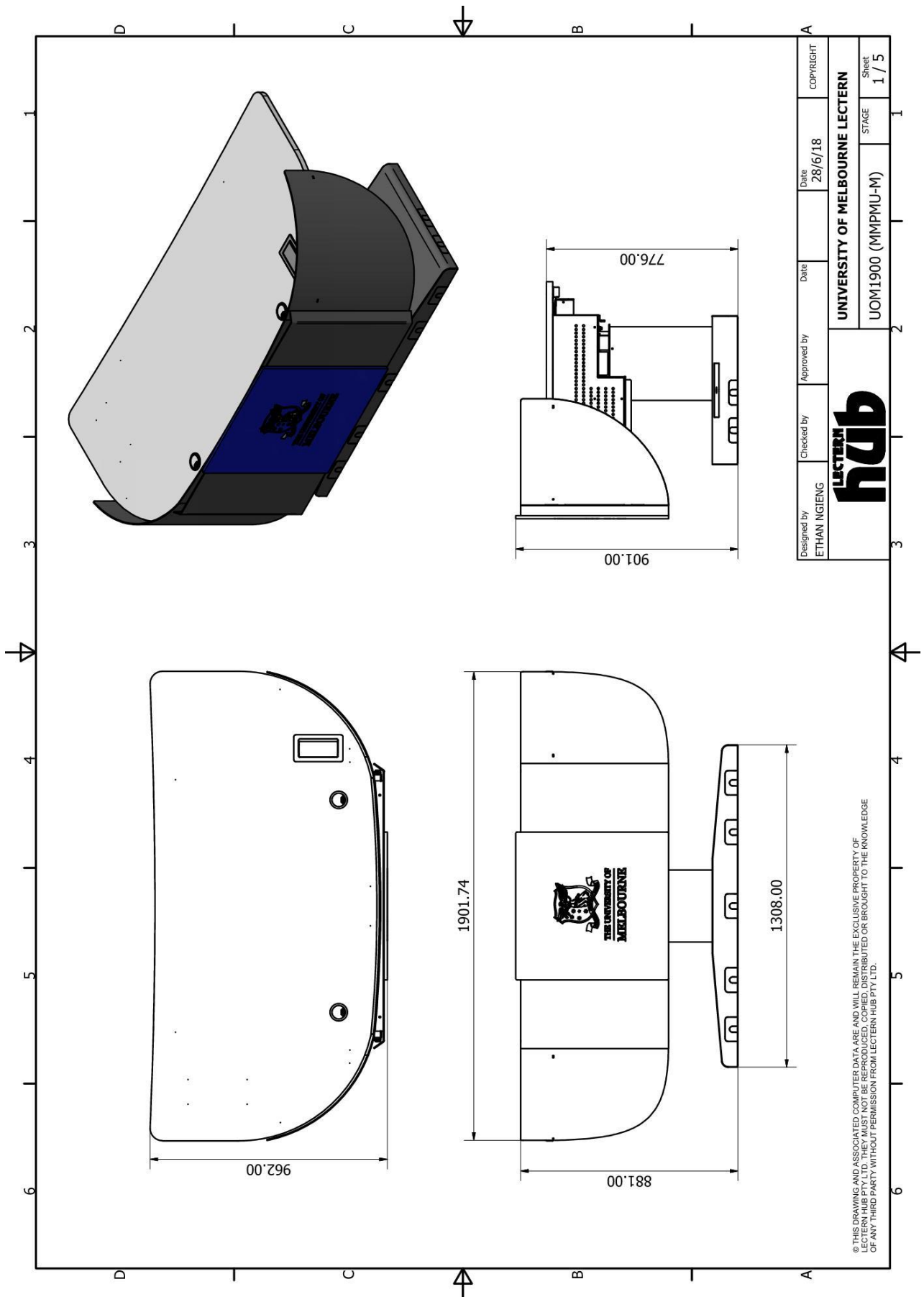

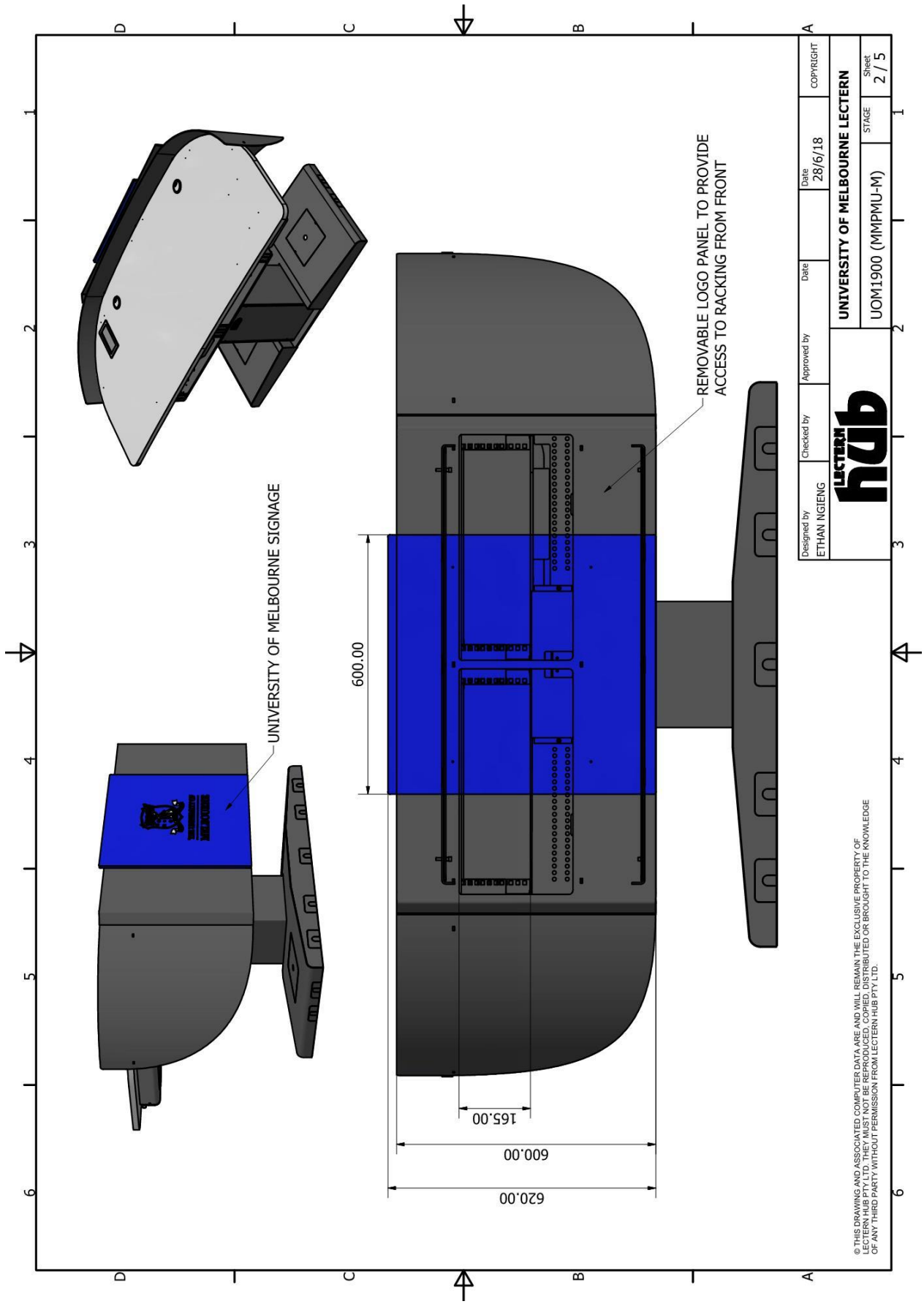

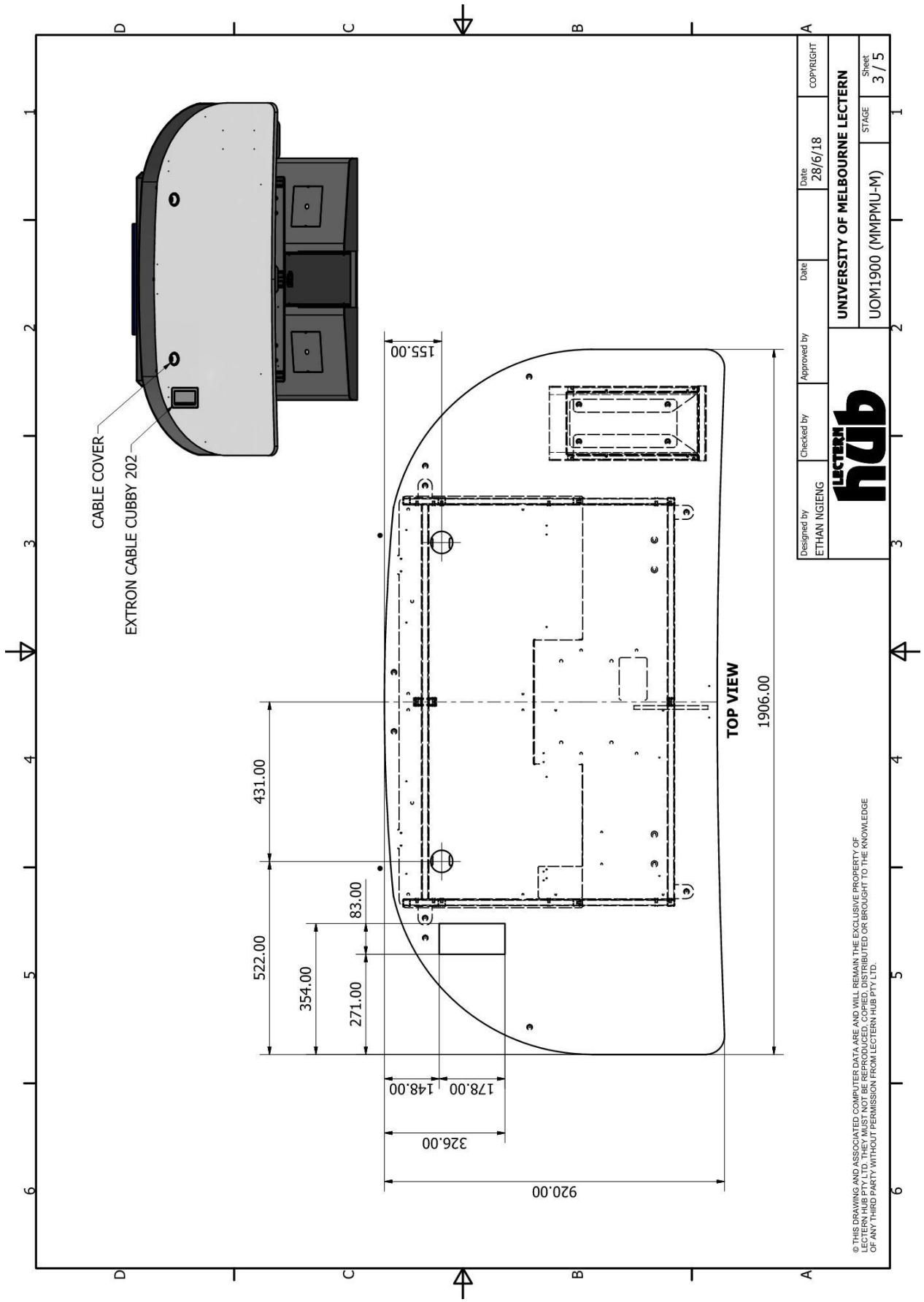

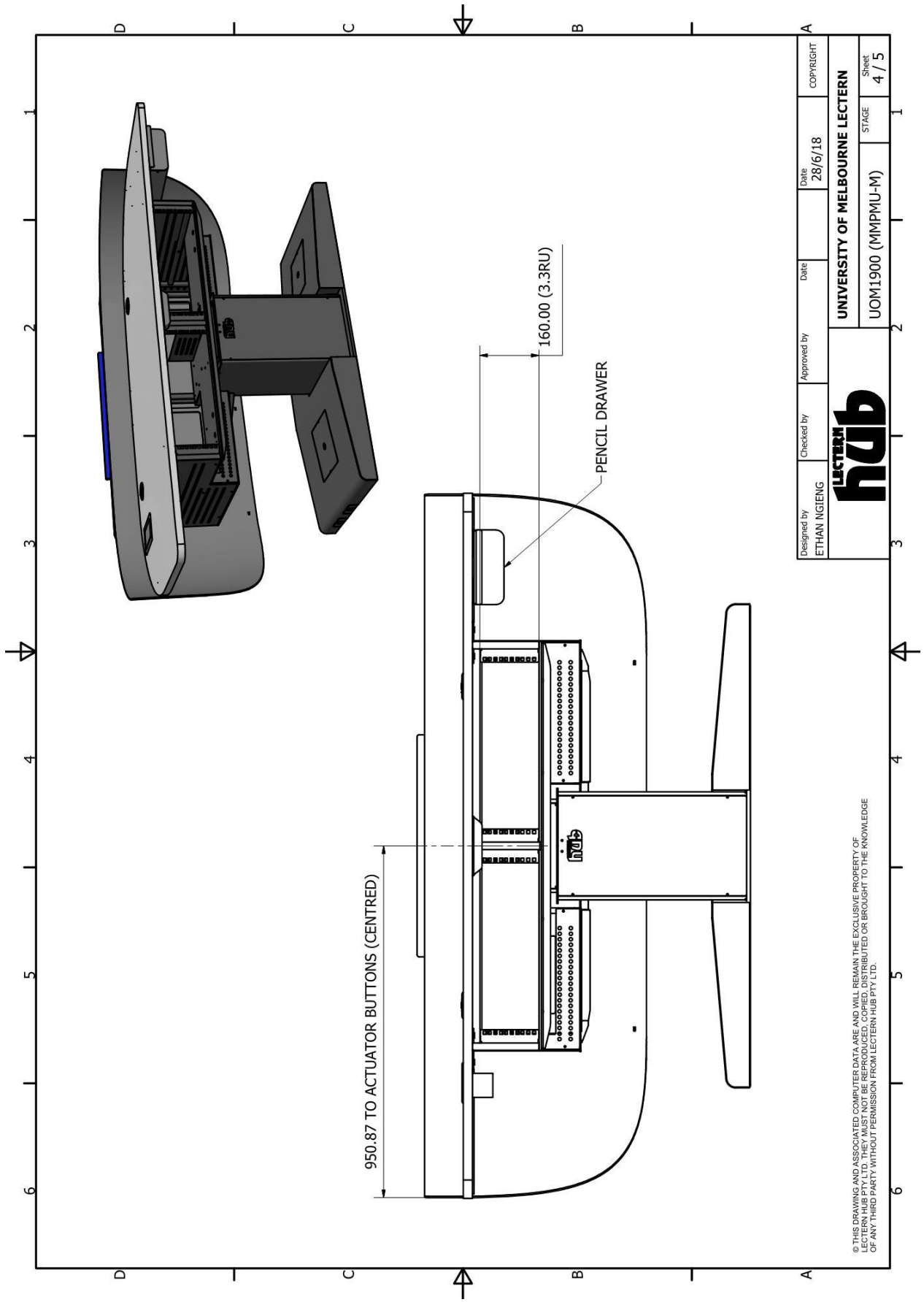

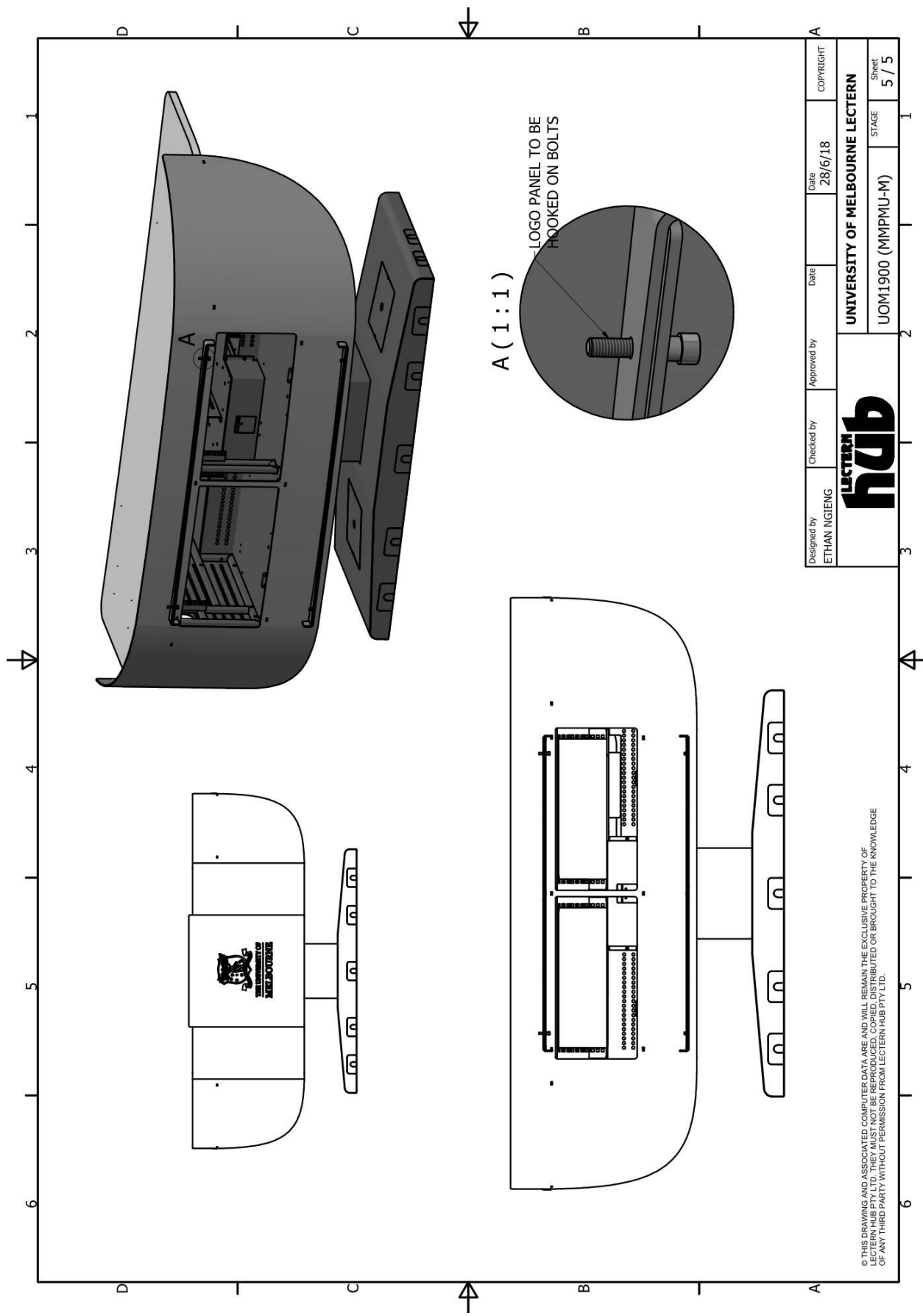

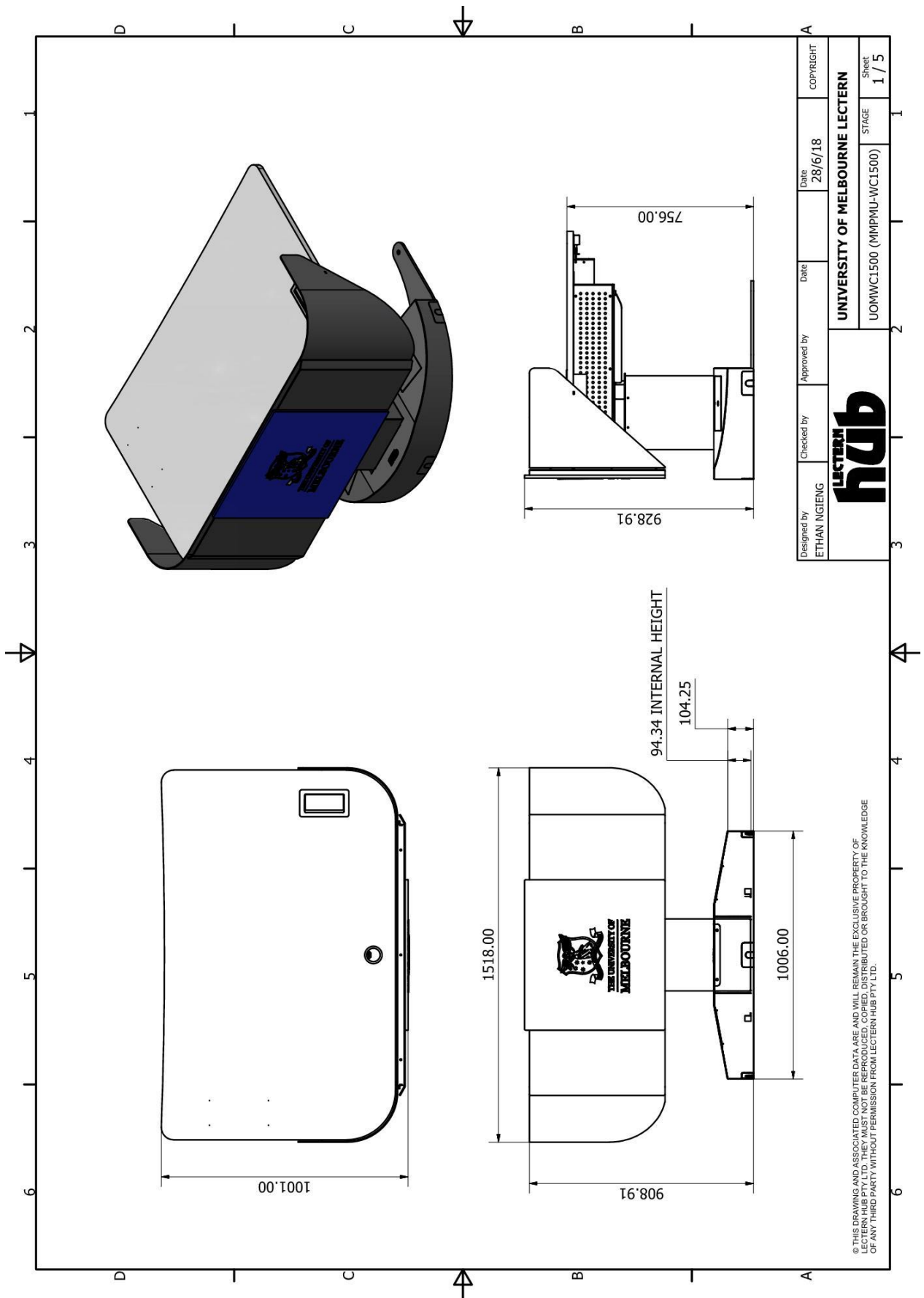

Designed by ETHAN NGIENG	Checked by	Approved by	Date 28/6/18	COPYRIGHT
			UNIVERSITY OF MELBOURNE LECTERN	
			UOM1900 (MPPMU-M)	STAGE 5 / 5

© THIS DRAWING AND ASSOCIATED COMPUTER DATA ARE AND WILL REMAIN THE EXCLUSIVE PROPERTY OF LECTERN HUB PTY LTD. THIS DRAWING IS NOT TO BE REPRODUCED OR Brought TO THE KNOWLEDGE OF ANY THIRD PARTY WITHOUT PERMISSION FROM LECTERN HUB PTY LTD.



© THIS DRAWING AND ASSOCIATED COMPUTER DATA ARE AND WILL REMAIN THE EXCLUSIVE PROPERTY OF LECTERN HUB PTY LTD. THIS DRAWING IS NOT TO BE REPRODUCED OR BROUGHT TO THE KNOWLEDGE OF ANY THIRD PARTY WITHOUT PERMISSION FROM LECTERN HUB PTY LTD.

Designed by ETHAN NGIENG	Checked by	Approved by	Date 28/6/18	COPYRIGHT
			UNIVERSITY OF MELBOURNE LECTERN	
			UOMWC1500 (MMPMU-WC1500)	STAGE 1 / 5

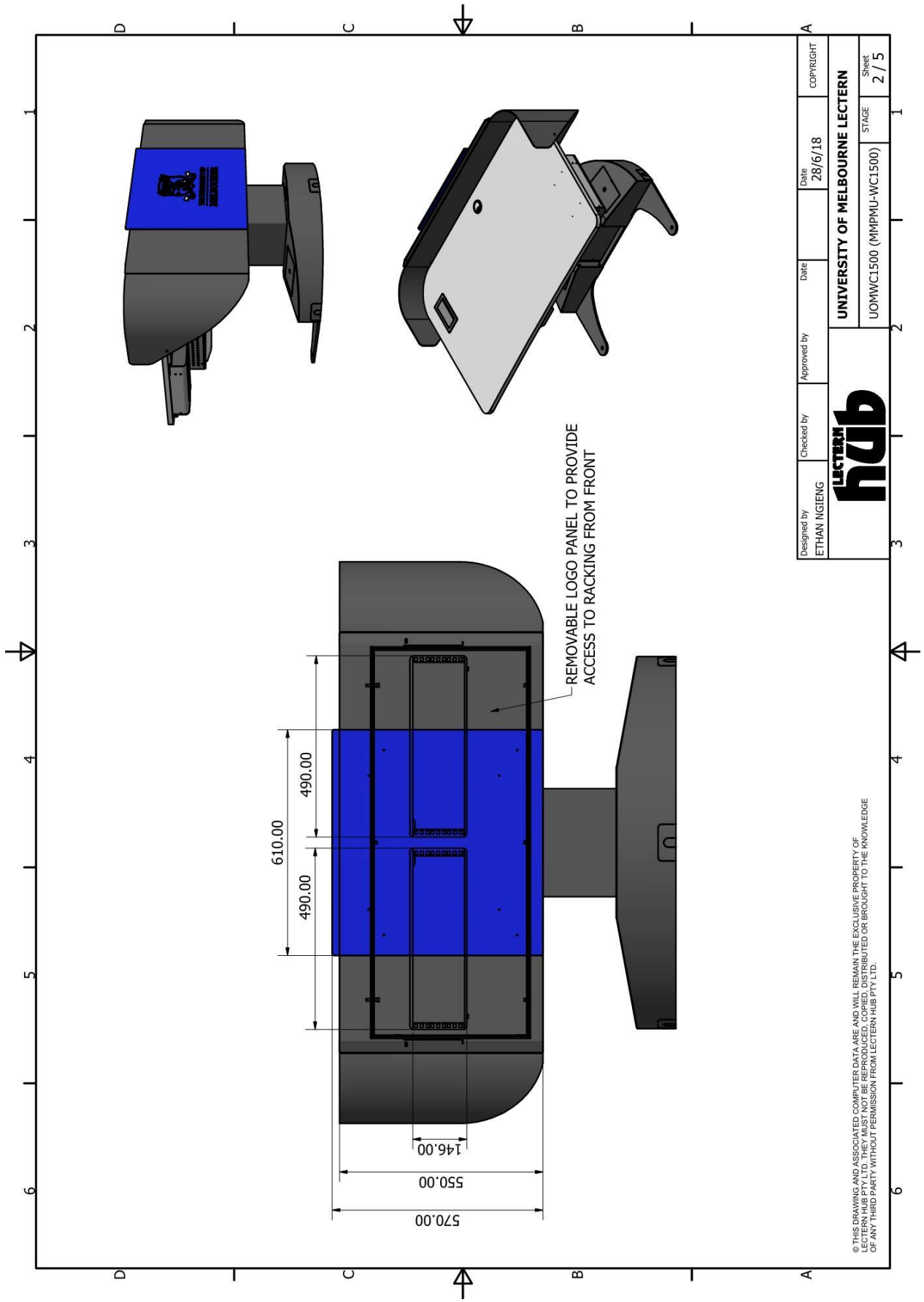

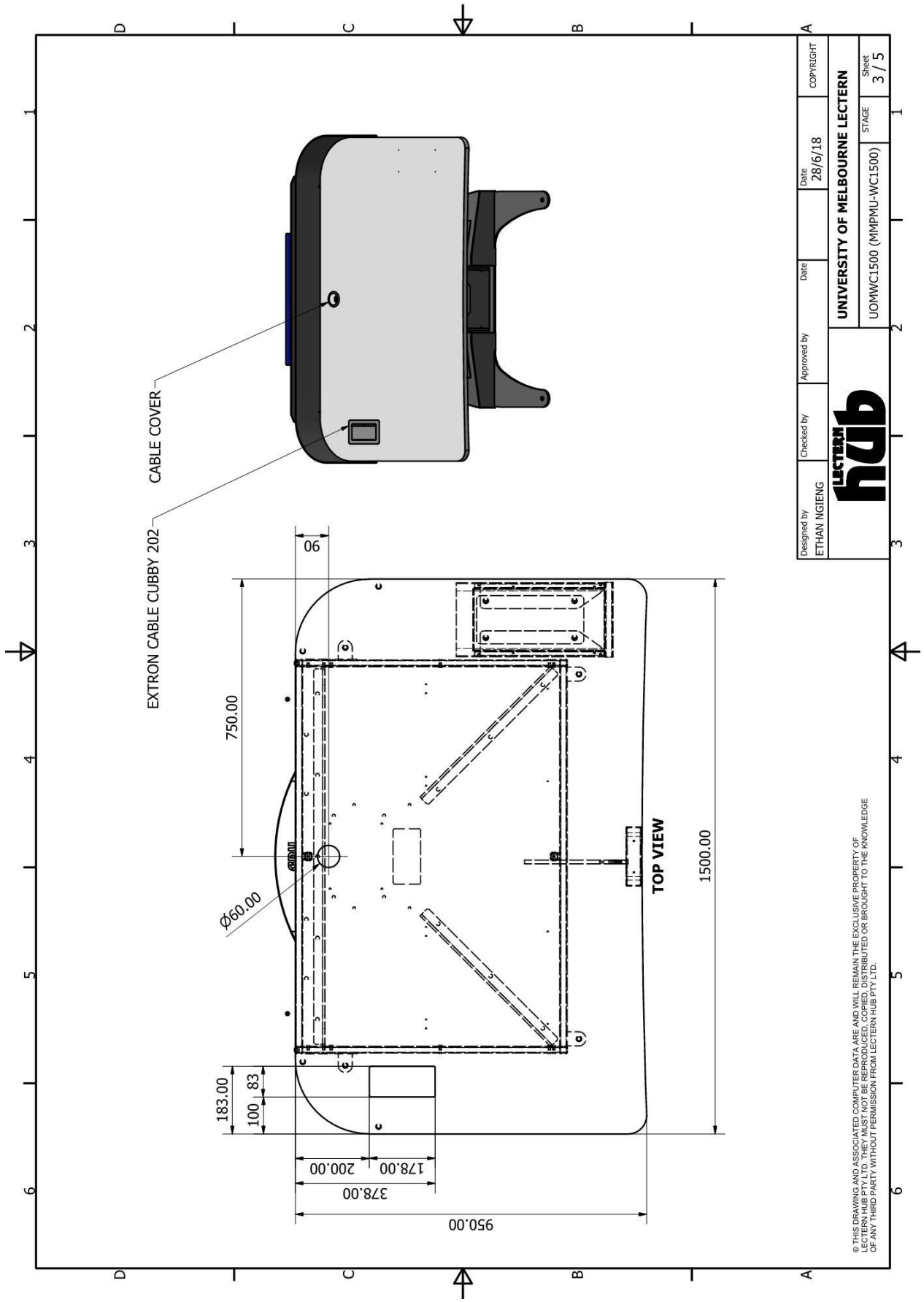

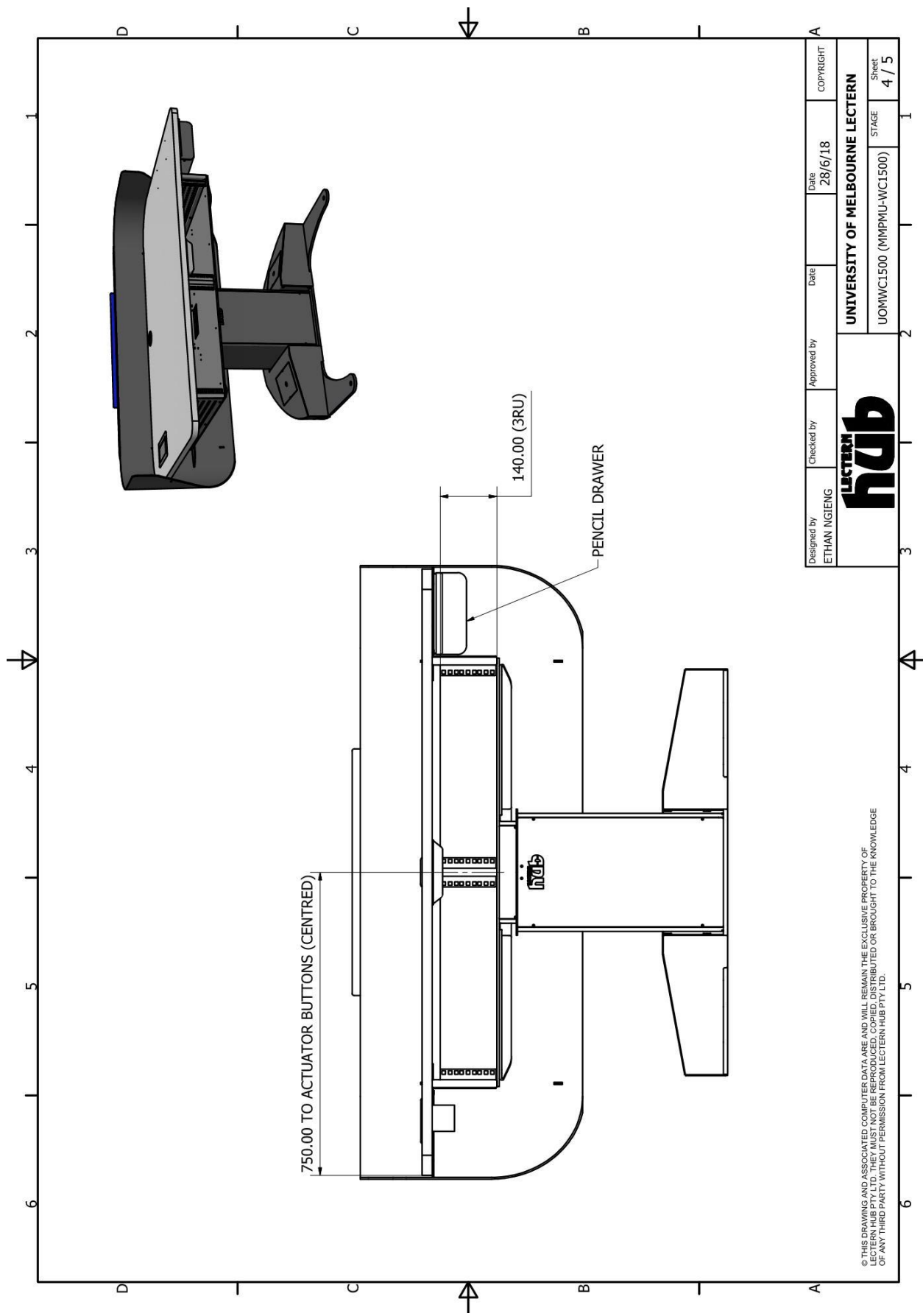

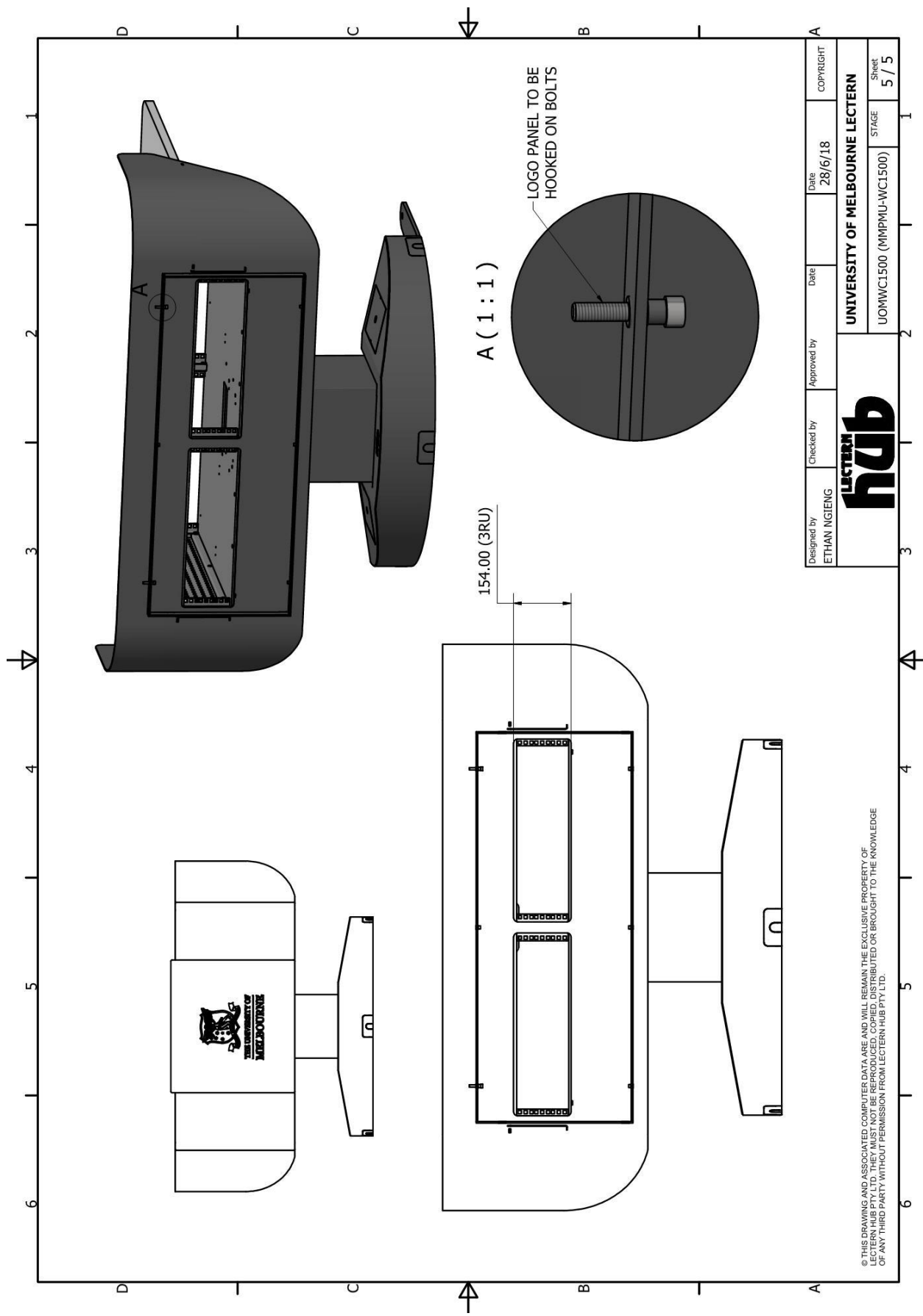

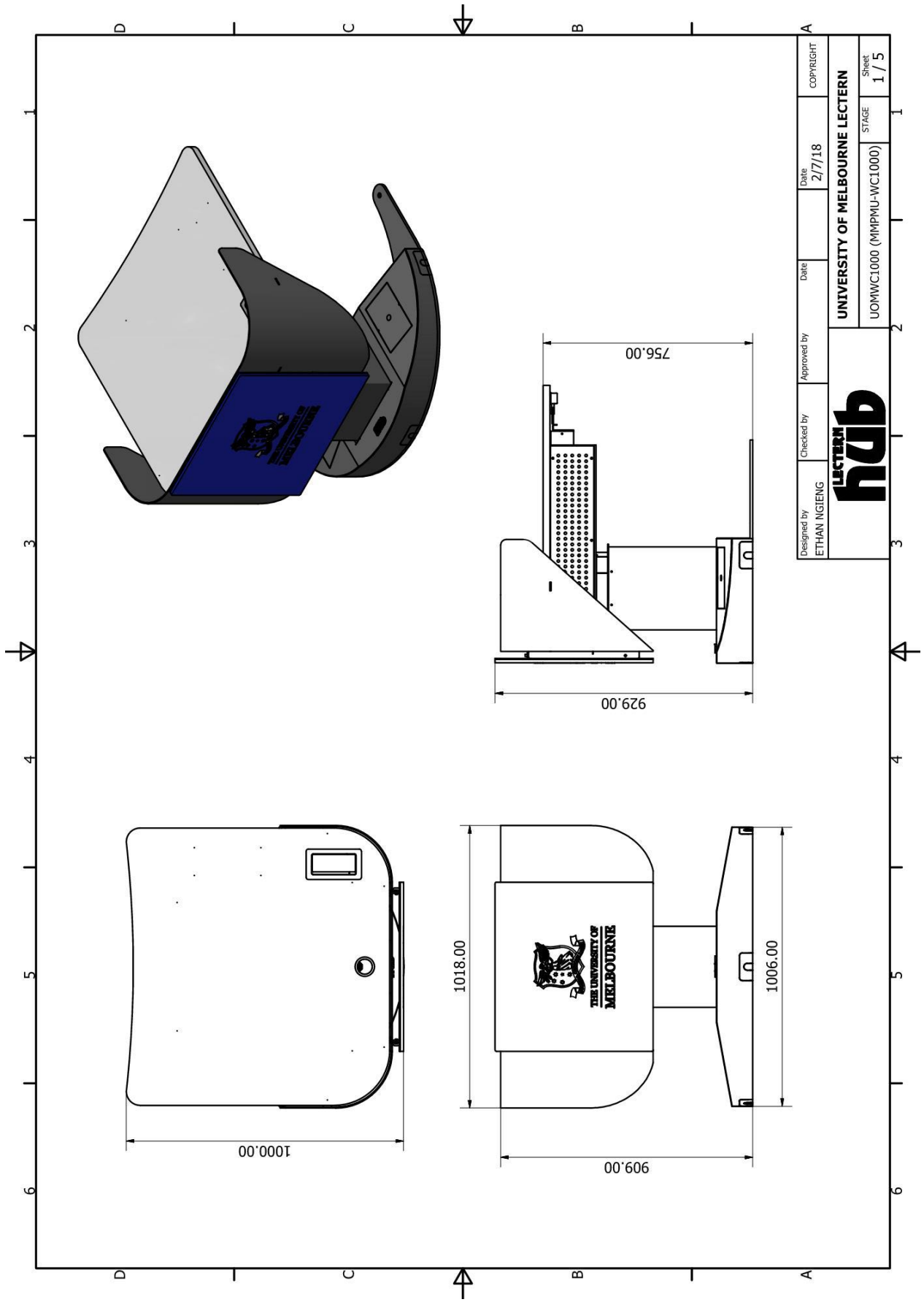

© THIS DRAWING AND ASSOCIATED COMPUTER DATA ARE AND WILL REMAIN THE EXCLUSIVE PROPERTY OF LECTERN HUB PTY LTD. THIS DRAWING IS NOT TO BE REPRODUCED OR DISTRIBUTED OR BROUGHT TO THE KNOWLEDGE OF ANY THIRD PARTY WITHOUT PERMISSION FROM LECTERN HUB PTY LTD.

Designed by ETHAN NGIENG	Checked by	Approved by	Date 28/6/18	COPYRIGHT
			UNIVERSITY OF MELBOURNE LECTERN	
			UOMWC1500 (MMPMU-WC1500)	STAGE 5 / 5

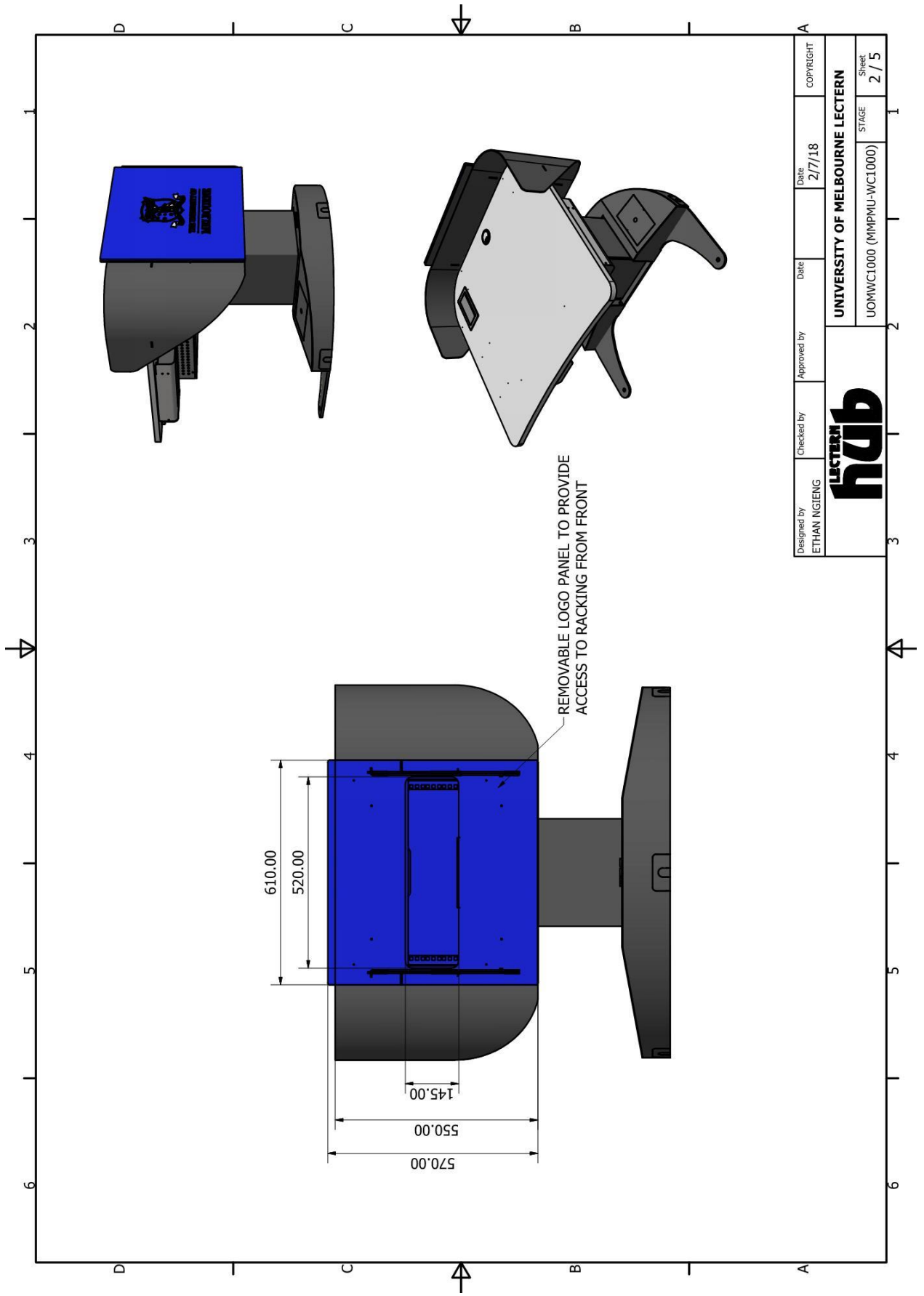

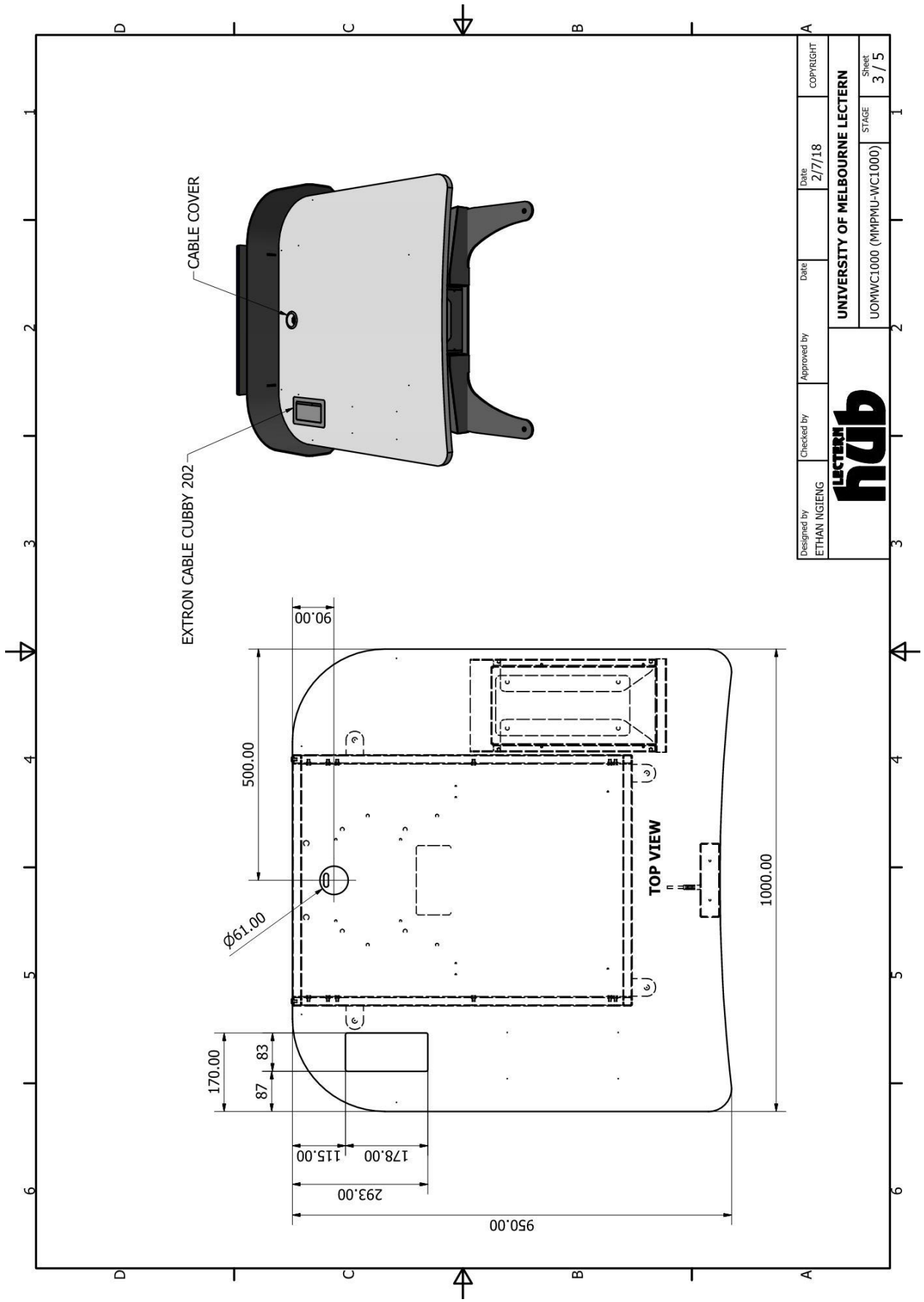



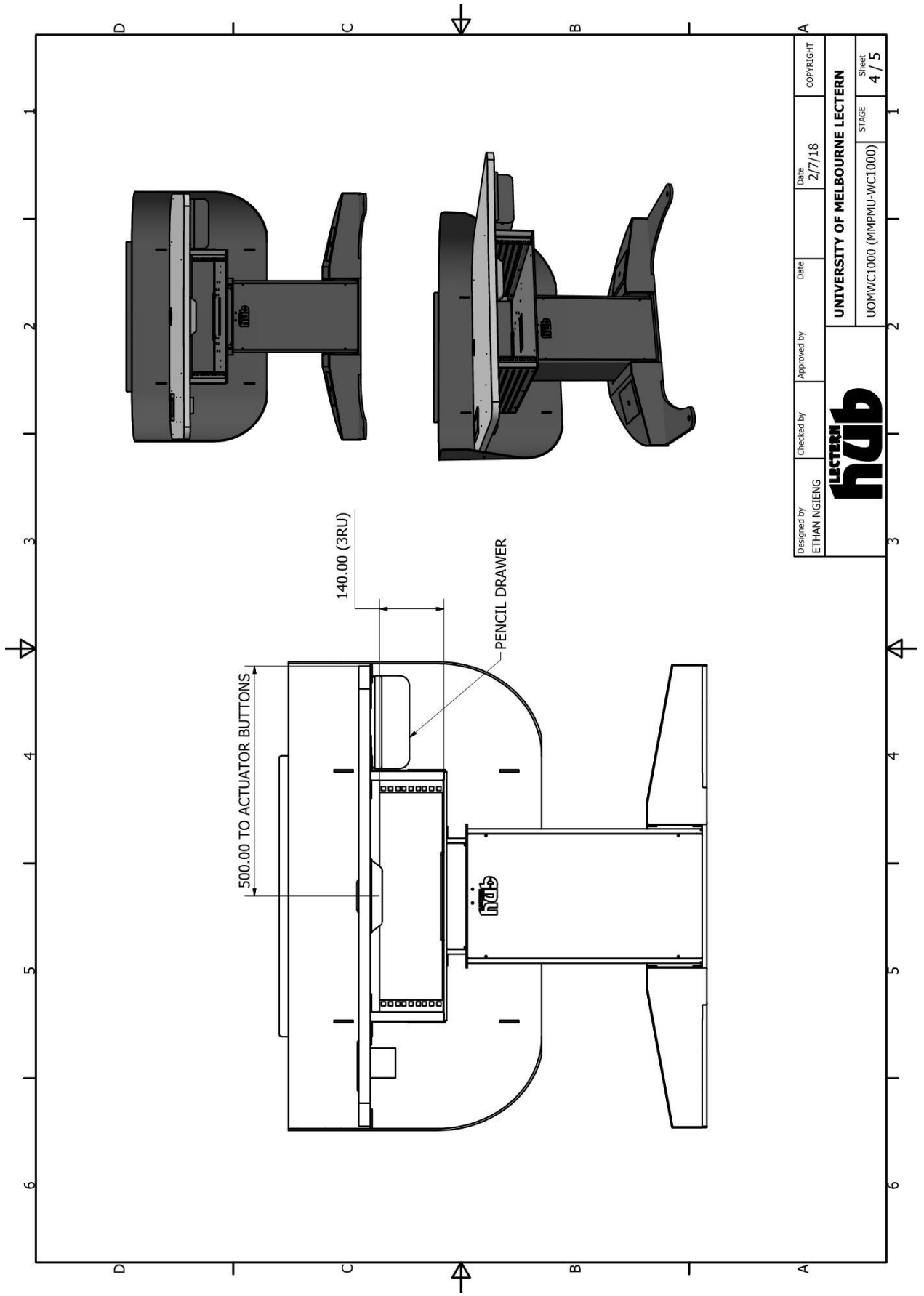

Designed by ETHAN NGIENG	Checked by	Approved by	Date 2/7/18	COPYRIGHT
			UNIVERSITY OF MELBOURNE LECTERN	
			UOMWC1000 (MMPMU-WC1000)	STAGE 3 / 5

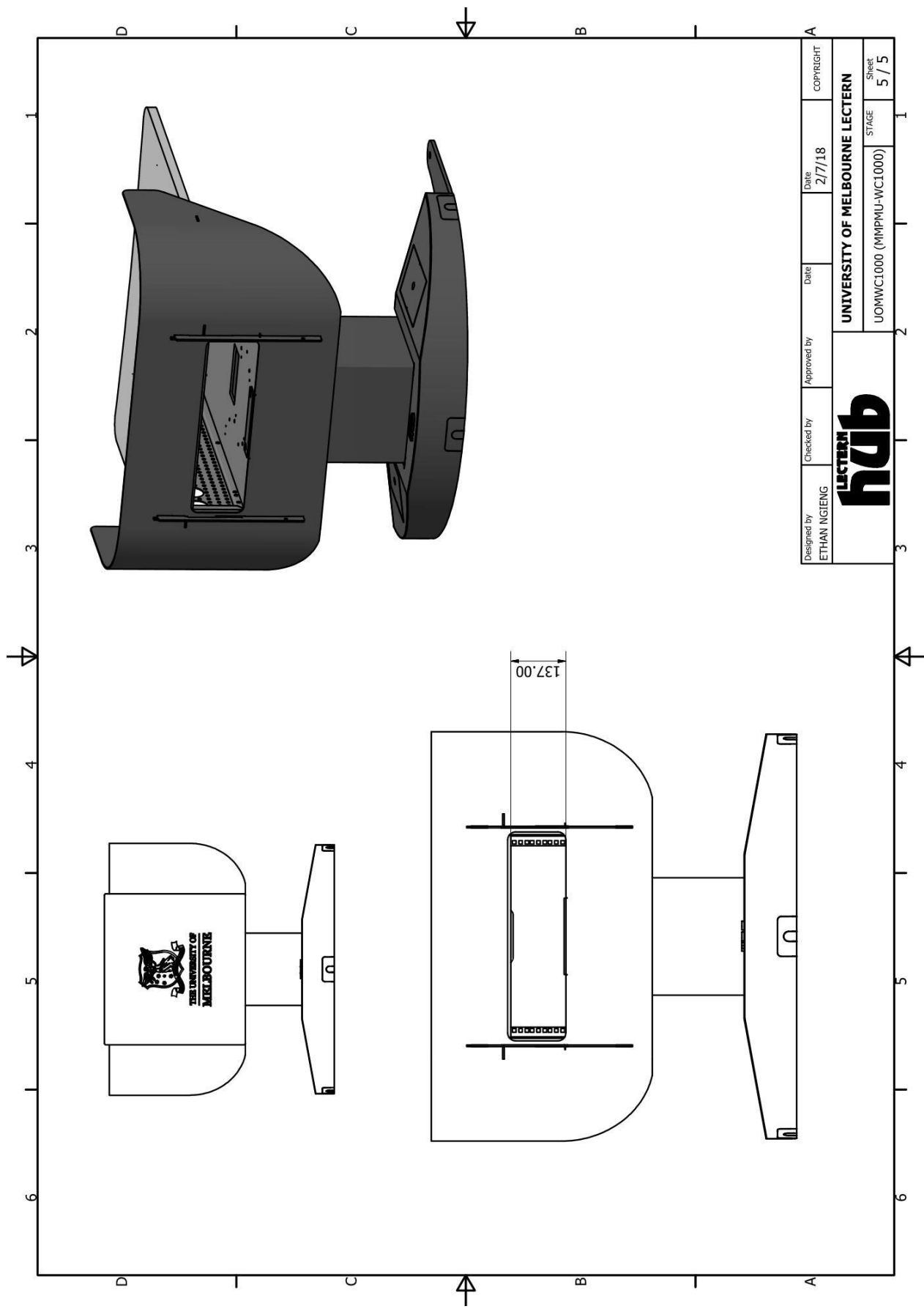

Designed by ETHAN NGIENG	Checked by	Approved by	Date 2/7/18	COPYRIGHT
 LECTERN hub			UNIVERSITY OF MELBOURNE LECTERN	
			UOMWC1000 (MMPMU-WC1000)	STAGE 4 / 5



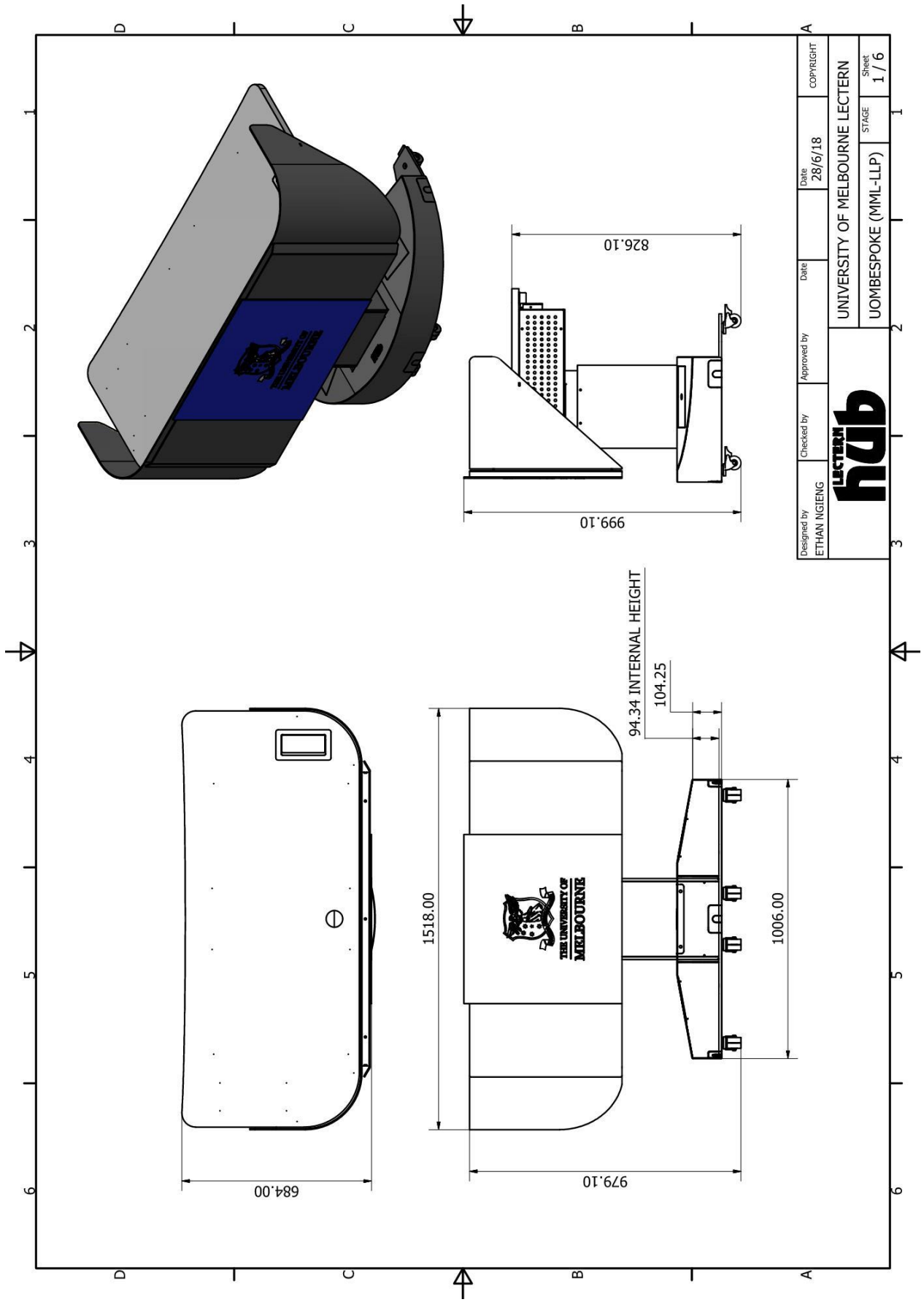

Designed by ETHAN NGIENG	Checked by	Approved by	Date 2/7/18	COPYRIGHT
			UNIVERSITY OF MELBOURNE LECTERN	
			UOM/WC1000 (MMPMU-WC1000)	STAGE 5 / 5

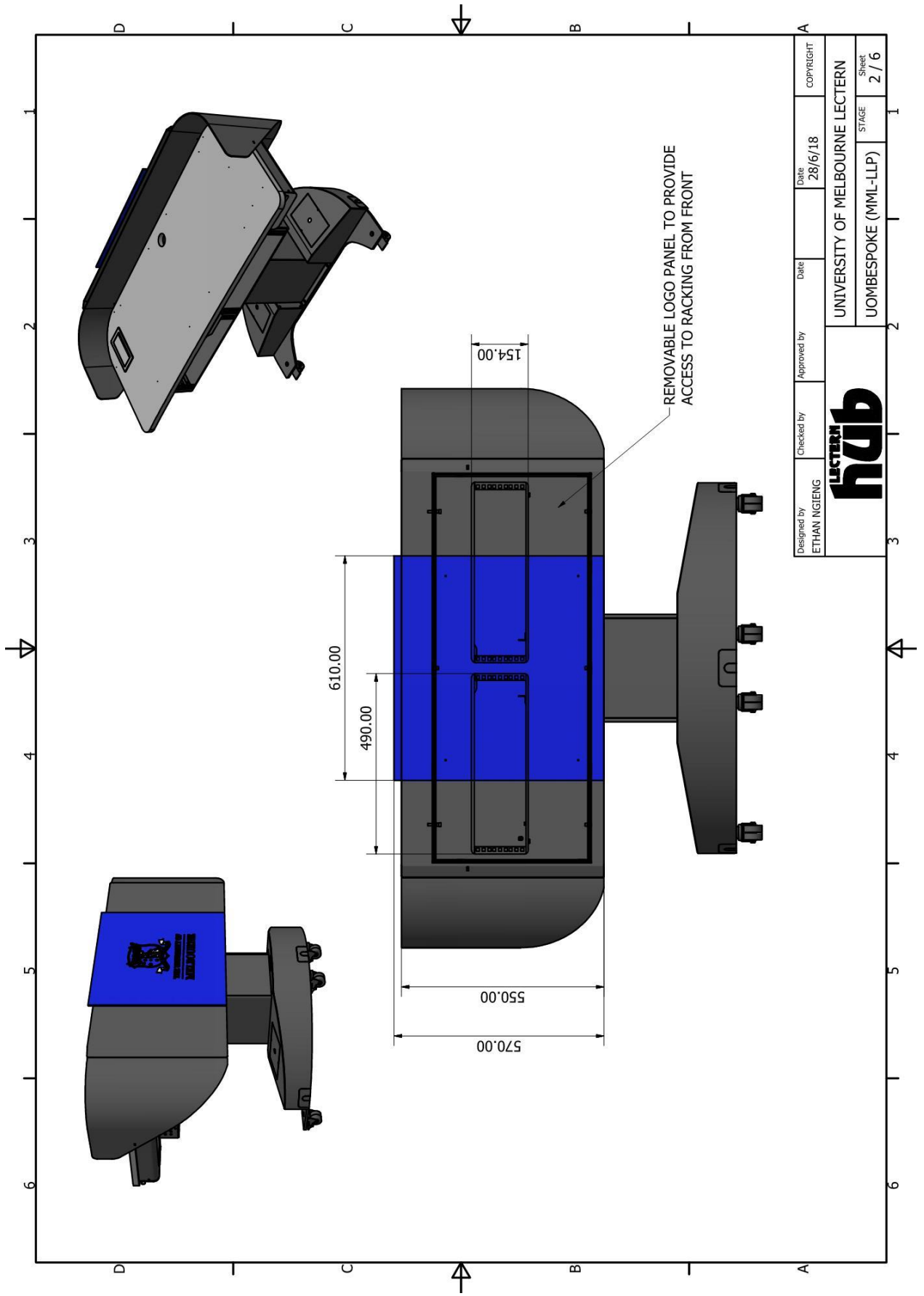

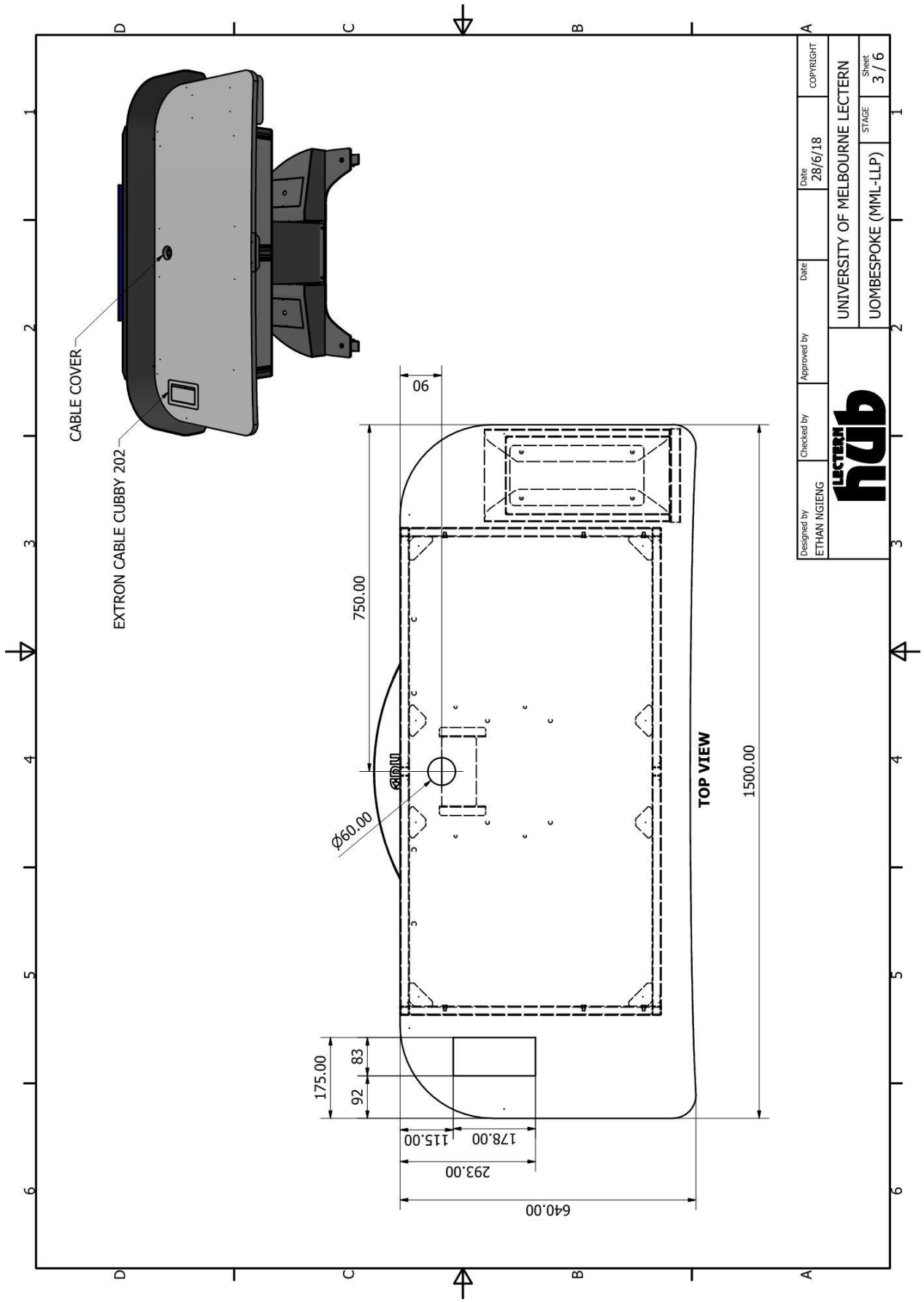

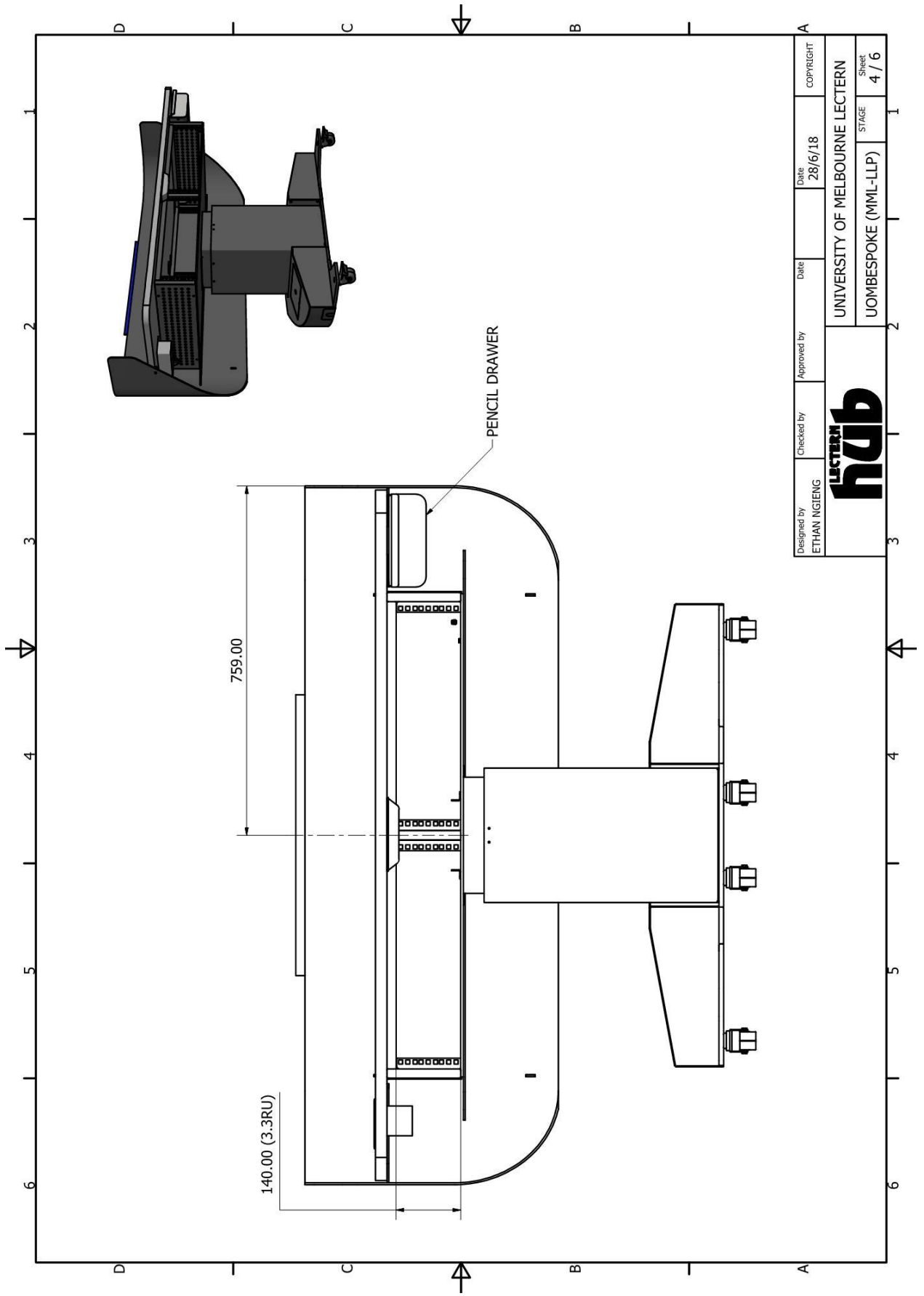





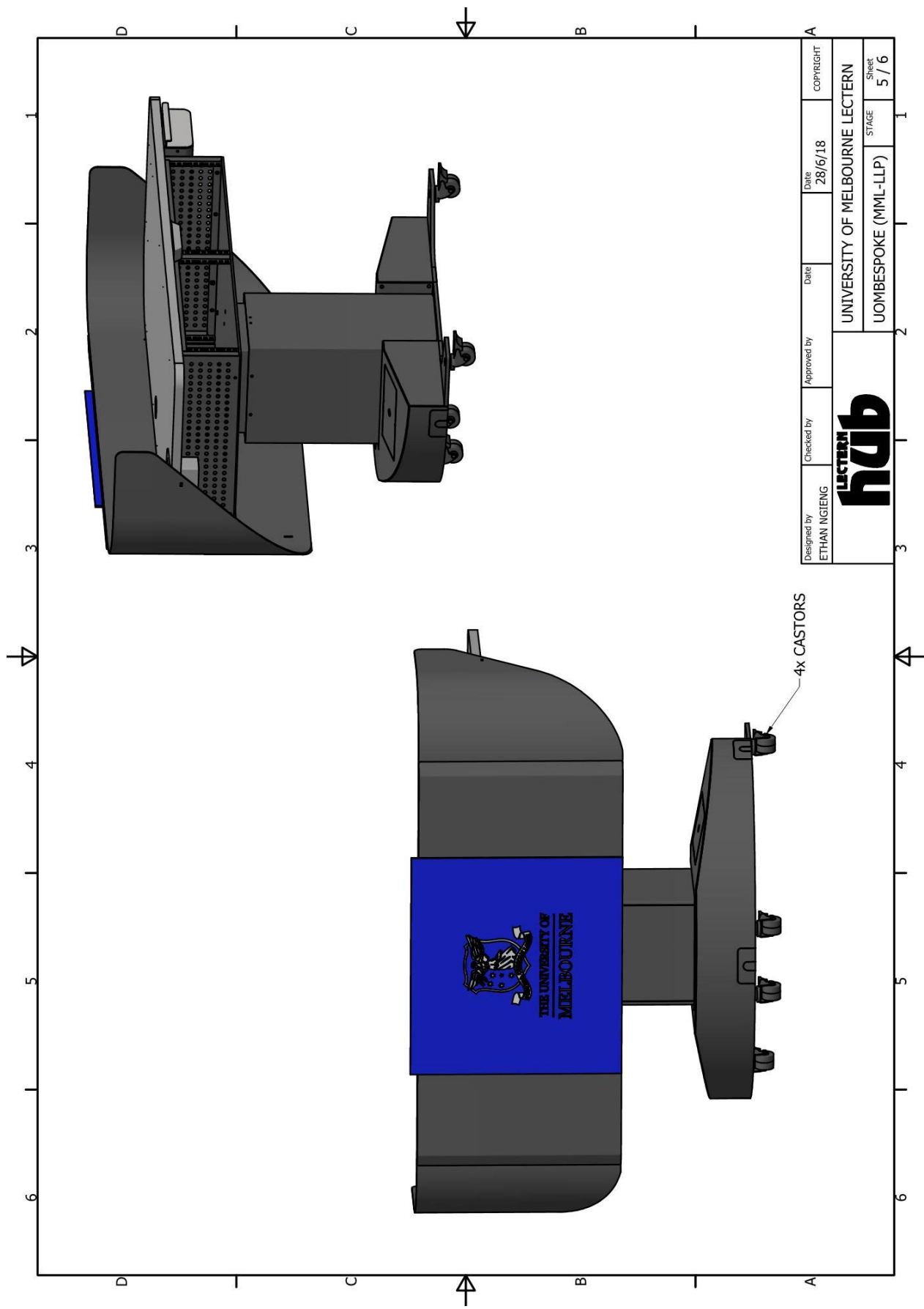

Designed by ETHAN NGIENG	Checked by	Approved by	Date 28/6/18	COPYRIGHT
			UNIVERSITY OF MELBOURNE LECTERN	
			UOMBESPOKE (MML-LLP)	Sheet 4 / 6

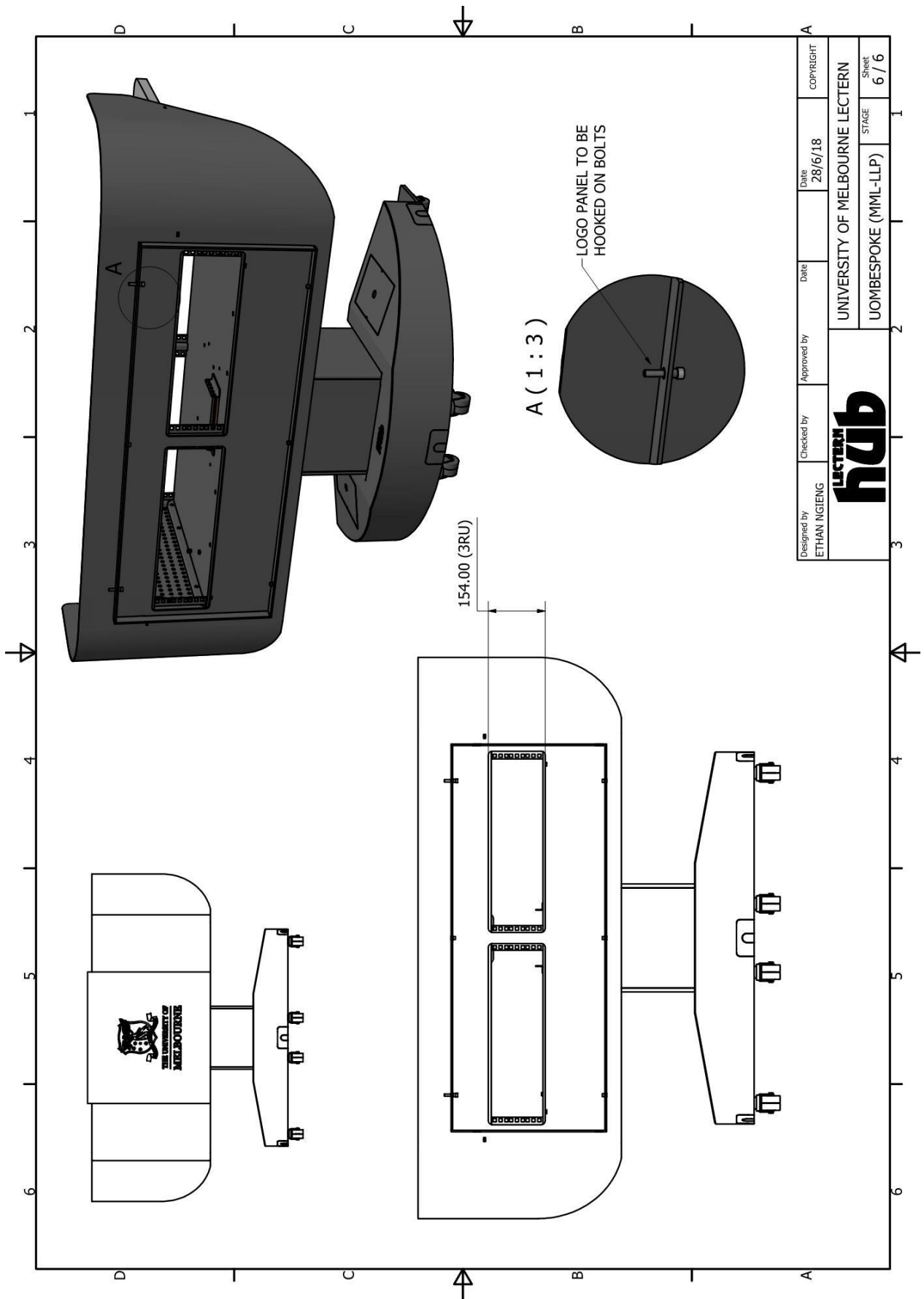

Designed by ETHAN NGIENG	Checked by	Approved by	Date 28/6/18	COPYRIGHT
 LECTERN hub			UNIVERSITY OF MELBOURNE LECTERN	
			UOMBESPOKE (MML-LLP)	



Designed by ETHAN NGIENG	Checked by	Approved by	Date 28/6/18	COPYRIGHT
			UNIVERSITY OF MELBOURNE LECTERN	
			UOMBESPOKE (MML-LLP)	
			STAGE	Sheet 6 / 6

APPENDIX F DIGITAL SIGNAGE COMMISSIONING SHEET

**UNIVERSITY OF MELBOURNE
SAMSUNG MAGIC INFOR - DIGITAL SIGNAGE SETUP**



Job Name: _____

Date: _____

Completed By: _____

Connect LCD to the LAN port on the wall.
NOTE THE LAN PORT NUMBER HERE: _____

WIRED CONNECTION Confirmed

- 1 Press the **MENU** button on the remote control.
- 2 Select **Network** - Open Network Settings.
- 3 Select **Wired**. – The network test screen appears and then the verification process starts.
- 4 When the connection has been verified, select **OK**

NETWORK STANDBY Confirmed

- 1 Press the **MENU** button on the remote control.
- 2 Select **System** - Open **System Settings**.
- 3 Select **Power Control**
- 3 Select **Network Standby** – ensure this is **ON**

CONNECT TO SERVER Confirmed

- 1 Press the **MENU** button on the remote control.
- 2 Select **Network** - Open Network Settings.
- 3 Select **Server Network Settings**
- 3 Select **Connect to Server**
Enter :::: 172.24.80.81

LCD INFO Confirmed

- 1 Press the **MENU** button on the remote control.
 - 2 Select **Support**
 - 3 Select **Contact Samsung**
- Advise all the Relevant Data:

Serial Number: _____

WIRED MAC Address (not wireless): _____

**SECTION 19: COMMUNICATIONS INFRASTRUCTURE
CONTENTS**

19.1	INTRODUCTION	2
19.2	WIRED & WIRELESS DATA NETWORKS	3
19.2.1	User Requirements Gathering	3
19.2.2	Network Design and Documents.	3
19.3	TELEPHONE SYSTEMS	4
19.3.1	User Requirements and Design	4
19.3.2	Budgets	5
19.3.3	Telephone Handsets	5

19.1 INTRODUCTION

The University's Infrastructure Services (IS) group within University Services (US) is responsible for the design and management of all University telecommunications infrastructure (including wired and wireless data, voice and video communications).

All projects that include new Communications Infrastructure installations (including telecommunication cabling, wired and wireless networking infrastructure) must have a IS Network Engineer assigned to them. The Network Engineer must approve any cabling designs and active network equipment model selections to ensure it is consistent with the University's overall Network Architecture and standards specifications.

The University presently maintains two key specification documents used in the specification, design and deployment of Communications Infrastructure, which consultants shall comply with:

- Standards for the Installation of Communications Infrastructure (SICI) – the current version is available on the University's Design Standards web page.
- Computer and Network Accommodation Strategy (CANAS) - the current version is available on the University's Design Standards web page.

This section provides a brief introduction to these documents and some concepts within to assist in compliance with the specifications. The assigned IS Network Engineer for works will also utilize the above specifications and inspect new installations for compliance and defects prior to hand-over.

A copy of the tender specification, schematic and/or floor plan shall be submitted to the assigned IS Network Engineer for approval prior to the issuing of documents for tender.

A complete wired data, wireless data and voice communications network integrated into the University's infrastructure is to be documented for by the Consultants. The Consultant shall be responsible for:

- Incorporating a network that meets the University's requirements and is endorsed by the IS assigned Network Engineer as being operable and compatible with the University's general Communications Infrastructure, Standards and Architecture;
- Documenting the design to the comply with the above Communications Infrastructure standards (SICI and CANAS). Any installation that does not comply with these Standards shall not be connected to the University network infrastructure;
- Including in the project budget all costs necessary to have the designed Communications Infrastructure and associated services fully operational on occupation by the Users (e.g. racks/cabinets, data network switches for wired communications, wireless network access points, telephony services, programming of numbers and appropriate maintenance/support in place, etc.);
- Ensure that any Trade Contractor(s) complies with the University Communications Infrastructure Standards (SICI and CANAS as listed above);
- Ensure that the US assigned Network Engineer inspects and approves the network(s) for operational use at the completion of the pre-commissioning tests.

19.2 Wired & Wireless Data Networks

19.2.1 User Requirements Gathering

The Communications Consultant in conjunction with the Architect is to ascertain the initial communications requirements of the Users to cover:

- Description of the number and type of users (e.g. indicating numbers of staff and students that different spaces are to support);
- Expected usage profiles of the space (e.g. types of rooms, theatres, open spaces, meeting rooms etc.) and any advanced user requirements (e.g. high density wireless, research computing, real-time location services requirements);
- Any advanced usage requirements of a space that would be considered above and beyond standard University space and usage (e.g. Commercial usages, high requirement collaborative spaces, support of advanced technologies, etc.)
- Initial estimation of the number and location of data outlets (see the SICI specification in regards to UoM standards for number of outlets per working area);
- Any required fibre optic cabling (to meet requirements in the SICI specification);
- Any non-communications technology components (e.g. Desktop computing, Server computing, Printers, etc.) are not covered by the Communications Infrastructure design, however information on potential usages is required to ensure the Communications Infrastructure supports the intended usage/devices.

Note: In addition to the above information, it is important to note that as of 2018, the University has a desire to explore opportunities for a “wireless first” approaches to building network design for users and devices. This may include additional wireless design and infrastructure to support a reduced deployment of physical network cabling. Any new product deemed suitable should be authorised by the Assigned UoM Network Engineer.

19.2.2 Network Design and Documents.

Cost Estimates (based on user requirements):

- Network Equipment cost estimates and deployment time estimates will be provided to the UoM Project Manager by the IS assigned Network Engineer. The Network Engineer will require the above User Requirements Gathering information to generate these cost estimates. More accurate information will result in more accurate estimates.

Physical Network Design (Data Outlet Floor Plans/as-built showing data outlets):

- The Consultant will need to ensure data outlet location design balances user requirements with adherence to UoM standards and the IS Network Engineer will need to approve the final data outlet location plan.
- The consultant will need to facilitate the final data outlet location plan by bringing together building tenant representatives, Project Staff and the IS Network Engineer to agree on the outlet numbers and locations.
- Test results will need to be provided to the University by the Contractor (facilitated by the Consultant or University Project Manager)

Logical Network Design:

- An initial Detailed Building Network Deployment Design document will be completed by the IS assigned Network Engineer subsequent to receiving the agreed floorplan/outlet location information.

- This will be updated prior to handover to Operational support with any updates made during deployment.

Wireless Design:

- Wireless Design shall be undertaken by a UoM IS assigned Wireless Network Engineer only, at the relevant project phase (working with the primary assigned IS Network Engineer) – Construction/Building consultants are NOT to provide any wireless design or estimates.
- Preliminary Wireless Design work will be undertaken to facilitate cost estimation, based on available User Requirements gathering information as captured above).
- Further design refinements will be undertaken on receipt of floor plans (predictive survey) and final design will be provided by the Wireless Engineer during initial deployment (based on actual site surveys and any remediation work undertaken at that stage to fine tune coverage due to any obstructions).

Device Commissioning requests:

- The University has a template for requesting addressing/commissioning of core building networked services (e.g. BMS, AV, Security) required to commission the building. This will be provided to any external party commissioning devices during construction and must be completed and sent to the IS Network Engineer in order to activate (patch/program) new devices.

The design of the wired and wireless data networks is to be done on separate drawings to the electrical installation. All documentation is to be submitted to the IS assigned Network Engineer for approval at the preliminary budget stage and prior to tendering the works.

19.3 Telephone Systems

The University currently deploys a Cisco IP Telephony system as its main telephony delivery mechanism. There are cases in which certain telephony services will not be able to be connected to the IP Telephony system or will require connection through an Analog to digital medium (such as NBN provided gateways, University Voice Gateways or 3G/4G services). Examples of this include any existing direct exchange line, lift phones and fax services. For these cases the project budget will need to account for provision of required additional services to support these usages.

19.3.1 User Requirements and Design

As per section 19.2.1 above, the Communications Consultant, in conjunction with the Architect, is to audit the existing telephone installation and determine from the Users their new requirements:

- Types of Telephony handsets and locations;
- Quantities of new and re-used handsets;
- Number of new extensions;
- Fax machine points;
- Whether telephony cabling in the building has to be upgraded.
- Where any of the above requires non-IP telephony based services (e.g. NBN services, Voice Gateway Analog services, 3G/4G services, mobile augmentation)

The Consultants are to prepare marked-up drawings in consultation with the Users. The design of the telephone installation is to be done on a separate drawing to the electrical installation and all documentation is to be submitted to the assigned IS Network Engineer

for approval at the preliminary budget stage and prior to tendering the works.

19.3.2 Budgets

The consultant shall allow in the budget for:

- The current cost of each Telephony handset;
- The cost of providing fax machine extensions;
- Programming of extensions;
- All analogue cable requirements between the installation and the Campus MDF.

19.3.3 Telephone Handsets

The Consultant shall approach IS, through the project Co-ordinator, for the current cost of each item and make allowance for the purchase of handsets and the programming of new extensions in the project contract documentation as a Prime Cost item.