



Family Name

Given Name

Student Number

Centre

Signature

23 June 2010

6077AC Electrical Systems Safety – Capstone Assessment

Time allowed – Three hours plus Ten minutes reading time

29 Pages in this Question Booklet

TOTAL MARKS AVAILABLE =100

Aids to be supplied by college:

- None.

Aids to be supplied by student:

- Australian/New Zealand Wiring Rules AS/NZS 3000:2007 incorporating amendment 1.
- Australian/New Zealand Electrical Installations – Selection of Cables AS/NZS 3008.1.1:1998 or 2009.
- Service and Installation Rules of NSW incorporating amendment 2.
- AS/NZS 3017:2007 Electrical Installation Testing Guidelines.
- Student's own marginal notes, indexing and formal amendments may be included in the above regulation books.
- Pen, pencil, eraser, rule, calculator.

Section	Possible Marks	Achieved Marks
A	15	
B	20	
C	45	
D	20	
Total	100	

Instructions to student:

- **Mobile phones are to be turned off and removed from your person.** You cannot access a mobile phone during this examination.
- All questions are to be attempted.
- All questions to be answered in the space provided in this **examination paper**. Answers to Section A (multiple choice questions) are to be answered on the sheet attached to this examination paper.
- You are not to use any other reference books in this examination.
- The whole of this paper is to be handed to the supervisor upon completion.

Aids permitted where indicated:

Standard Dictionaries	Bilingual Dictionaries	Technical Dictionaries	Programmable Calculators	Non-programmable Calculators	Electronic Devices
No	No	No	No	Yes	No

SECTION A – (15 Marks)

Instructions: Select the best answer for the following statements and place an “X” in the appropriate box on the Answer Sheet attached to this examination paper. Each correct answer is worth ONE (1) mark.

QUESTION 1. (1 Mark)

It is required to earth the structural metalwork forming the frame of a dwelling in a domestic installation. How can this connection be made?

- (a) 4 mm² bonding conductor provided that the resistance between the earth bar and any part required to be earthed does not exceed 0.5 Ω
- (b) 2.5 mm² protective earthing conductor provided that the resistance between the earth bar and any part required to be earthed does not exceed 0.5 Ω
- (c) appropriately sized protective earthing conductor at one point of the metalwork provided that the resistance between the earth bar and any part required to be earthed does not exceed 0.5 Ω
- (d) appropriately sized bonding conductor at one point of the metalwork provided that the resistance between the earth bar and any part required to be earthed does not exceed 0.5 Ω

QUESTION 2. (1 Mark)

What is the minimum allowable load current rating of a separate RCD installed in a domestic installation? The RCD is protecting two (2) final sub circuits each with a 10A CB. The total maximum demand of the two circuits is 9A.

- (a) 20A
- (b) 10A
- (c) 9A
- (d) Sum of individual circuit breakers

QUESTION 3. (1 Mark)

From AS/NZS 3000:2007, the maximum permissible voltage drop between the point of supply and the main switch on a 230V main switch board with several final sub-circuits attached is:

- (a) 5% U_o
- (b) 11.5 V
- (c) 5% of the voltage measured at the MSB
- (d) not prescribed

SECTION A – (Cont'd)

QUESTION 4. (1 Mark)

Under short circuit conditions, what is the maximum permissible sheath temperature for a 25 mm² PVC (V90) Cu single core cable?

- (a) 160°C
- (b) 90° C
- (c) 75° C
- (d) 250° C

QUESTION 5. (1 Mark)

What is the standard minimum depth of laying an enclosed service mains cable underground?

- (a) 300 mm
- (b) 500 mm
- (c) 600 mm
- (d) 1000 mm

QUESTION 6. (1 Mark)

The colour code that distinguishes a dry chemical powder fire extinguisher is:

- (a) red with white stripe
- (b) red with black stripe
- (c) blue
- (d) red

QUESTION 7. (1 Mark)

What is the maximum allowable earth leakage current for a 230V class I appliance with sheathed heating elements?

- (a) 30 mA
- (b) 0 mA
- (c) 0.22 mA
- (d) 23 mA

SECTION A – (Cont'd)

QUESTION 8. (1 Mark)

The sign shown in Figure 1 is an example of a:



Figure 1

- (a) prohibition sign
- (b) mandatory sign
- (c) restriction sign
- (d) warning sign

QUESTION 9. (1 Mark)

Automatic disconnection of the supply is required to limit the harmful effects of internal switchboard arcing. Protection should initiate at a current less than:

- (a) 20% of three phase prospective fault level
- (b) 20% of single phase prospective fault level
- (c) 60% of single phase prospective fault level
- (d) 30% of three phase prospective fault level

QUESTION 10. (1 Mark)

What is the maximum allowable resistance of an equipotential bonding conductor?

- (a) not specified
- (b) 2 Ω
- (c) 1 Ω
- (d) 0.5 Ω

SECTION A – (Cont'd)

QUESTION 11. (1 Mark)

With which standard must equipment installed in a hazardous area comply?

- (a) AS/NZS 2381.1
- (b) AS2209
- (c) AS3017
- (d) all of the above

QUESTION 12. (1 Mark)

After conducting a risk assessment, what is the first course of action taken to reduce risk?

- (a) elimination
- (b) PPE
- (c) substitution
- (d) administration

QUESTION 13. (1 Mark)

A Certificate of compliance of electrical work must be finalised when an electrical installation is tested. The section pertaining to testing should be completed by:

- (a) the consumer
- (b) the holder of the electrical contracting licence
- (c) the qualified supervisor (electrical) who completed the test
- (d) a registered installation inspector

QUESTION 14. (1 Mark)

The maximum disconnection time specified for protection against indirect contact for a final sub circuit protecting a lighting circuit is:

- (a) unspecified
- (b) 0.1 s
- (c) 0.4 s
- (d) 5 s

SECTION A – (Cont'd)

QUESTION 15. (1 Mark)

Every conductor shall have a current-carrying capacity that must be:

- (a) less than the current for which the circuit is designed (IB)
- (b) not less than the circuit breaker nominal rating (IN)
- (c) not greater than the current to be carried by the conductor
- (d) based on an ambient air temperature of 40°C

(END OF SECTION A)

SECTION B – (20 Marks)

Instructions: Blank spaces in the following statements represent omissions. Write the appropriate word, words or information in the spaces provided. Each question is worth TWO (2) marks. ONE (1) mark is deducted for each incorrect or missing reference. TWO (2) marks are deducted for each incorrect answer.

- Use AS/NZS 3000:2007 to best answer each question.
- **Include AS/NZS 3000 references where required.**

QUESTION 1. (2 Marks)

What distance is required between a combustible structural member and a recessed halogen lamp?

.....
.....

(AS/NZS 3000 Reference:)

QUESTION 2. (2 Marks)

Is it necessary to provide an equipotential bond to a conductive water pipe that is in contact with the ground and accessible from within a building?

.....
.....

(AS/NZS 3000 Reference:)

QUESTION 3. (2 Marks)

What is the minimum size and colour of the MEN connection in a main switchboard that is supplied by unprotected consumer mains?

.....
.....

(AS/NZS 3000 Reference:)

SECTION B – (Cont'd)

QUESTION 4. (2 Marks)

What is the maximum length of time a person can withstand a touch potential of 65V under wet conditions?

.....
.....

(AS/NZS 3000 Reference:)

QUESTION 5. (2 Marks)

Is it permissible to use bare copper cable as an earth electrode?

.....
.....

(AS/NZS 3000 Reference:)

QUESTION 6. (2 Marks)

What are the specific requirements (including IP rating) of a socket outlet installed within zone 2 of a sink having a capacity less than 45 litres?

.....
.....

(AS/NZS 3000 Reference:)

QUESTION 7. (2 Marks)

What is the minimum rating of a circuit breaker used to protect a domestic final sub circuit supplying a 12kW range?

.....
.....

(AS/NZS 3000 Reference:)

SECTION B – (Cont'd)

QUESTION 8. (2 Marks)

Is the following item of electrical equipment included in the classification of fire and smoke control equipment? Air handling systems intended to exhaust and control the spread of fire and smoke.

.....
.....

(AS/NZS 3000 Reference:)

QUESTION 9. (2 Marks)

List FIVE (5) criteria that need to be addressed when designing an electrical installation:

- (i)
- (ii)
- (iii).....
- (iv).....
- (v)

(AS/NZS 3000 Reference:)

QUESTION 10. (2 Marks)

Wiring systems associated with fire and smoke control equipment, evacuation equipment and lifts, shall be capable of maintaining an adequate supply to such equipment when:

.....
.....

(AS/NZS 3000 Reference:)

(END OF SECTION B)

Marks

SECTION C – (45 Marks)

Instructions: This section involves calculations. Show all necessary working in the space provided. Marks will be awarded accordingly. Answers are to be highlighted or underlined.

QUESTION 1. (4 Marks)

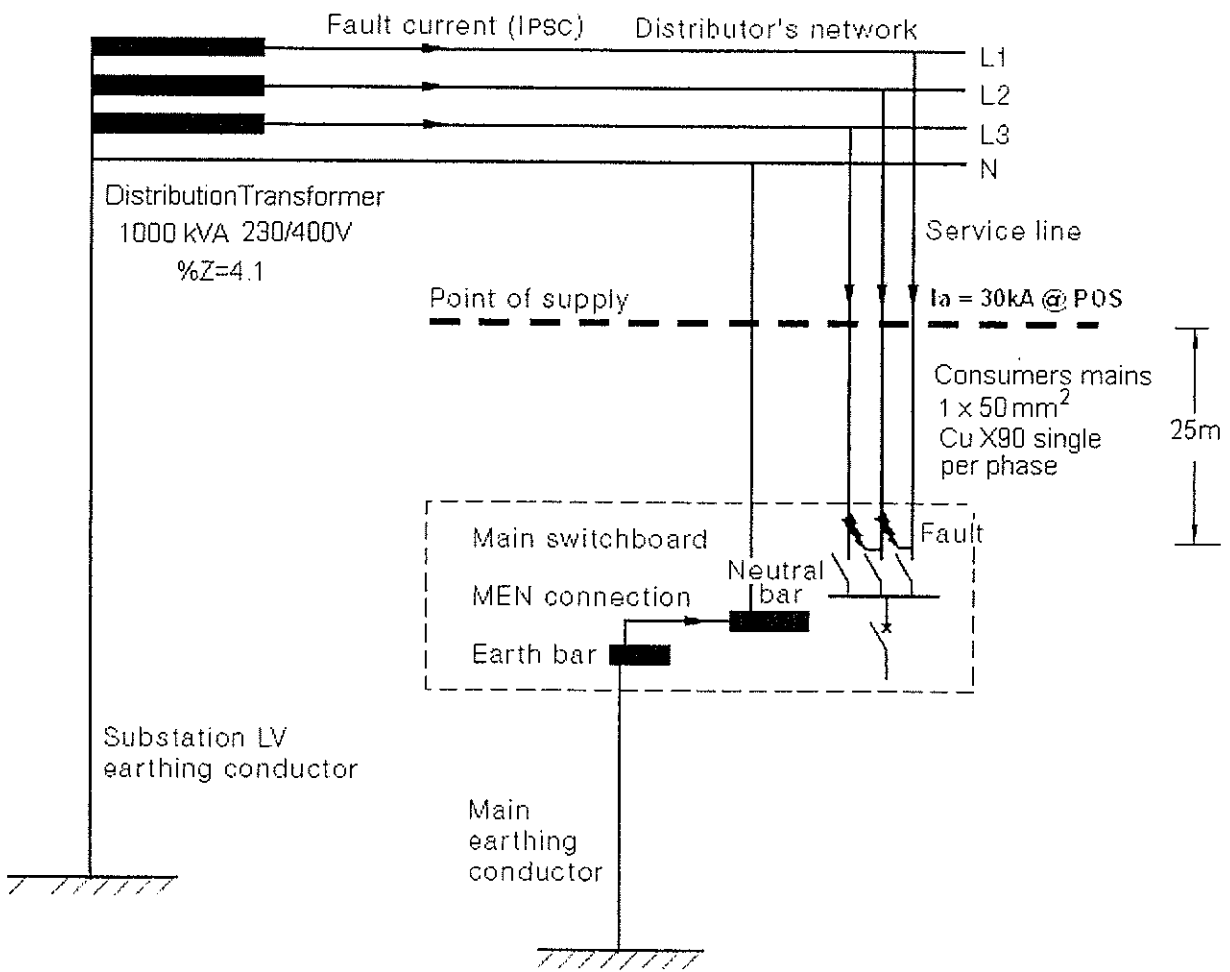

Figure 1

Parts a to d relate to Figure 1.

- (a) Determine the phase impedance of the distribution transformer.

.....

.....

.....

.....

.....

.....

Marks

SECTION C – (Cont'd)

QUESTION 1. (cont'd)

- 1 (b) Determine the distributor's network system impedance, for a 3 ϕ prospective fault current of 30kA at the point of supply.

.....
.....
.....
.....

- 1 (c) Assuming a bolted 3 ϕ fault at the M.S.B. as indicated on the diagram, calculate the maximum prospective short circuit current. The Consumer mains consist of 1 x 50 mm² Cu X90 SDI per phase with a route length of 25m. The maximum fault level at the Point of supply is 30kA, as indicated on the diagram. (AS3008 has appropriate tables for conductor resistance – ignore reactance.)

.....
.....
.....
.....
.....
.....
.....
.....

- 1 (d) From the list below choose a suitable interruption capacity for protective devices installed at the main switch board:

3kA
4.5kA
8kA
10kA
15kA

SECTION C – (Cont'd)

QUESTION 2. (4 Marks)

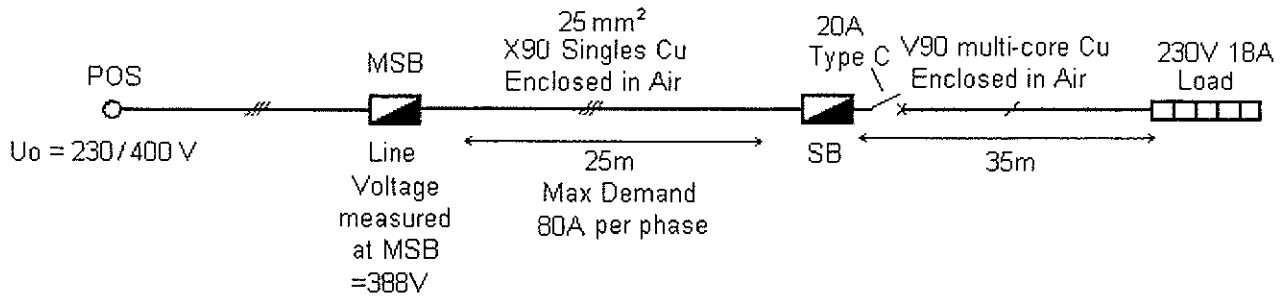

Based on VOLTAGE DROP, determine the minimum size cable for the SINGLE PHASE final sub circuit shown above.

.....

.....

.....

.....

.....

QUESTION 3. (4 Marks)

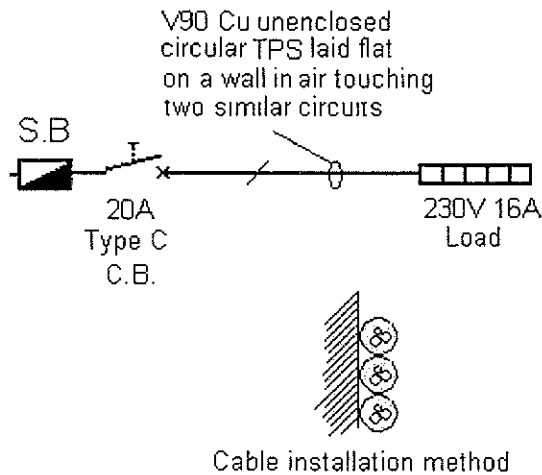

Based on CURRENT CARRYING CAPACITY, determine the minimum size cable for the SINGLE PHASE final sub circuit shown above.

.....

.....

.....

SECTION C – (Cont'd)

QUESTION 4. (4 Marks)

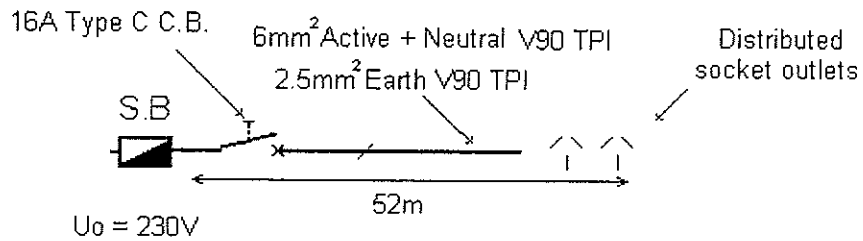

Based on FAULT LOOP IMPEDANCE, determine if the final sub circuit satisfies the requirements of AS/NZS 3000:2007. Show all references and working.

.....

.....

.....

.....

.....

.....

.....

.....

QUESTION 5. (4 Marks)

Determine the maximum demand for the following 230V SINGLE Domestic Installation:

- 36 x 50W down lights
- 18 x double 10A socket outlets
- 4 x single 10A socket outlets
- 1 x 8 kW 230V cooktop
- 1 x 3.6 kW 230V oven
- 1 x 15A socket outlet (general purpose)
- 1 x permanently connected 230V 8A split air conditioner
- 4 x permanently connected 115W ceiling fans
- 2 x 10A socket outlets installed > 2.4m for 65W exhaust fans
- 1 x 400 litre Solar hot water with a 20A quick recovery boost element

SECTION C – (Cont'd)

Load Group	Load / Qty	Calculation	Maximum Demand
Ai			
Aii			
Bi			
Bii			
Biii			
C			
D			
E			
F			
G			
Maximum Demand			

SECTION C – (Cont'd)

QUESTION 6. (7 Marks)

Determine the maximum demand for the following 230/400V three-phase MULTIPLE domestic installation, consisting of twenty five (25) individual living units.

Electrical equipment associated with each individual (1) unit:

22 x 50W down lights *A_i*

12 x double 10A socket outlets *B_i*

3 x single 10A socket outlets *B_i*

1 x 10A socket outlet for 230V air conditioner *B_i OR D*

2 x permanently connected 120W ceiling fans *A_i*

In addition to the load above, six (6) of the units have the following electrical loads.

1 x 11 kW 230V range *C*

1 x 4.8 kW electric storage hot water system *C*

The following communal load is also installed:

1 x 400V 3 ϕ 18A Atrium air conditioning system *D*

30 x 230V 100W security lights (10 lights per phase)

1 x 400V 35A 3 ϕ lift motor *T*

SECTION C – (Cont'd)

QUESTION 6. (Cont'd)

Use only the required load groups in the table below

Load Group	Load / Qty	Calculation	Red	White	Blue
Ai					
Aii					
Bi					
Bii					
Biii					
C					
D					
E					
F					
G					
H					
I					
Ji					
Jii					
Jiii					
K					
L					
M					
Maximum Demand					

SECTION C – (Cont'd)

QUESTION 7. (3 Marks)

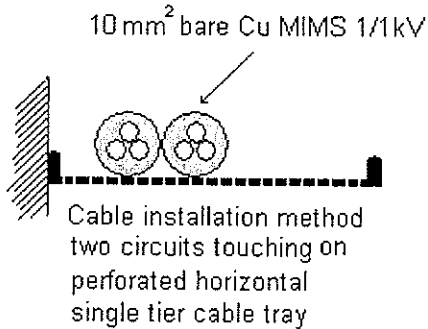

Determine the CURRENT CARRYING CAPACITY of the THREE phase 10 mm² bare multi-core Cu MIMS cable, which is installed flat on a perforated cable tray touching another similar circuit.

.....

.....

.....

QUESTION 8. (4 Marks)

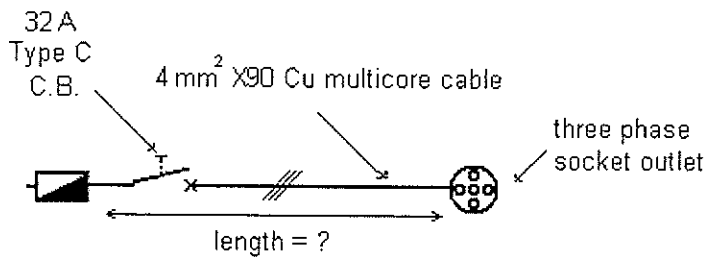

A 400V three phase final sub circuit supplying a socket outlet is to be wired with 4 mm² X90 four-core and earth cable. The circuit is protected by a 32A, type C circuit breaker. The voltage drop in the cables supplying the Sub Board is 3.1% of U₀. In order to comply with AS/NZS 3000:2007 regarding voltage drop, what is the maximum allowable route length of the circuit?

.....

.....

.....

.....

.....

SECTION C – (Cont'd)

QUESTION 10. (6 Marks)

Determine the maximum demand for the following 400V NON DOMESTIC RETAIL installation. Each retail shop has light, power and air conditioning loads. The office has light, power and variable volume air conditioning loads.

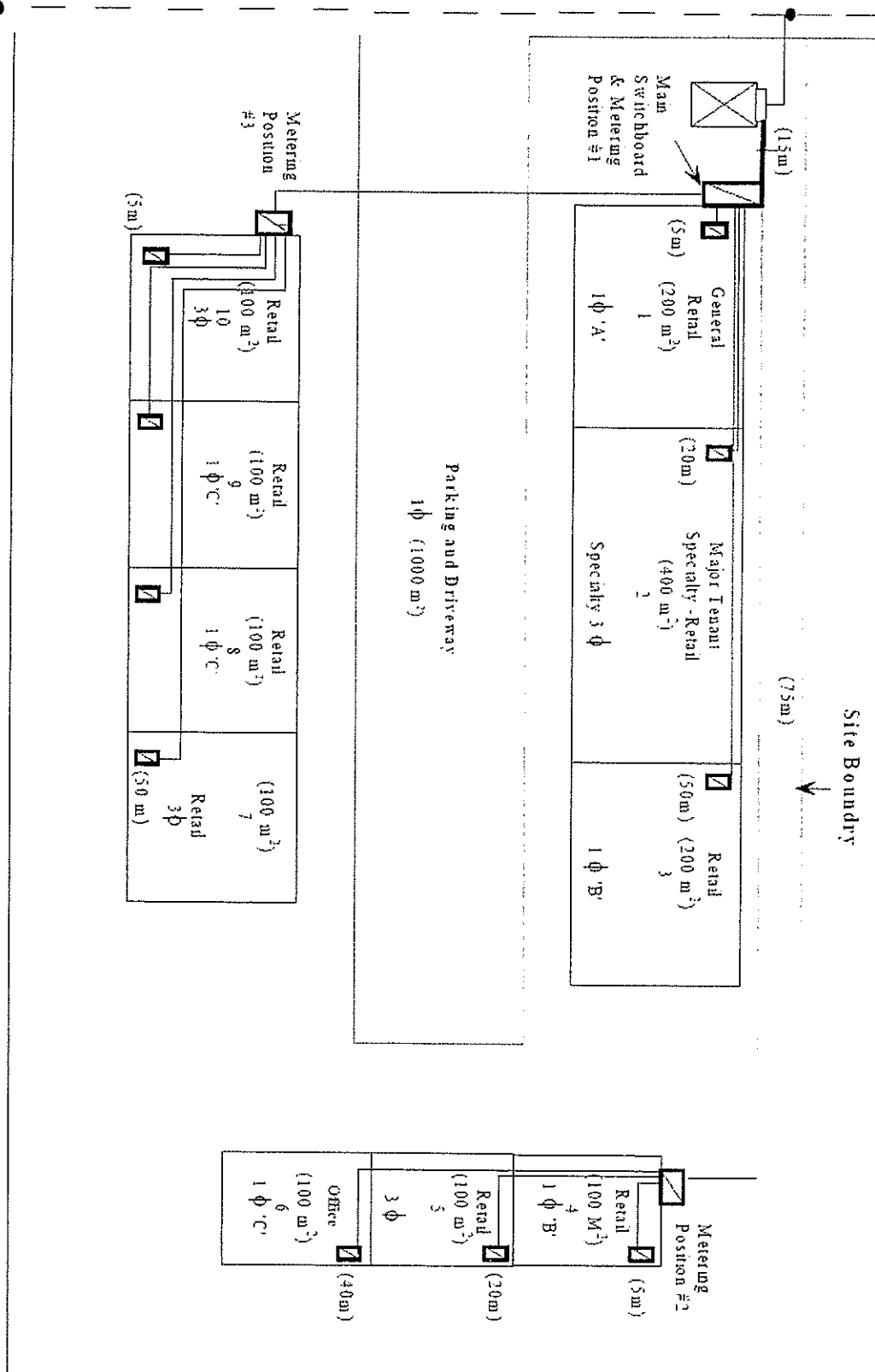

SECTION C – (Cont'd)

QUESTION 10. (Cont'd)

Unit	Area	Calculation	A	B	C
1					
2					
3					
4					
5					
6					
7					
8					
9					
10					
Carpark					
Maximum Demand					

(END OF SECTION C)

SECTION C – (Cont'd)

QUESTION 10. (Cont'd)

Unit	Area	Calculation	A	B	C
1					
2					
3					
4					
5					
6					
7					
8					
9					
10					
Carpark					
Maximum Demand					

(END OF SECTION C)

SECTION D – (20 Marks)

Instructions: The questions in this section require some simple drawing. Ensure that the drawing is neat and legible. The use of pencil on the drawing is acceptable in this section only.

QUESTION 1. (5 Marks)

The following diagram shows a sub board in a domestic installation. The sub mains include an active, neutral and earth from the MSB. There are four (4) final sub circuits supplying socket outlets, wired with 2.5 mm², multi-core, V90, Cu cables. The installation condition of all final sub circuits is **fully surrounded by thermal insulation**.

Complete all necessary active, neutral and earth connections for these four final sub-circuits on the wiring diagram below, ensuring the completed wiring complies with the relevant Australian Standards.

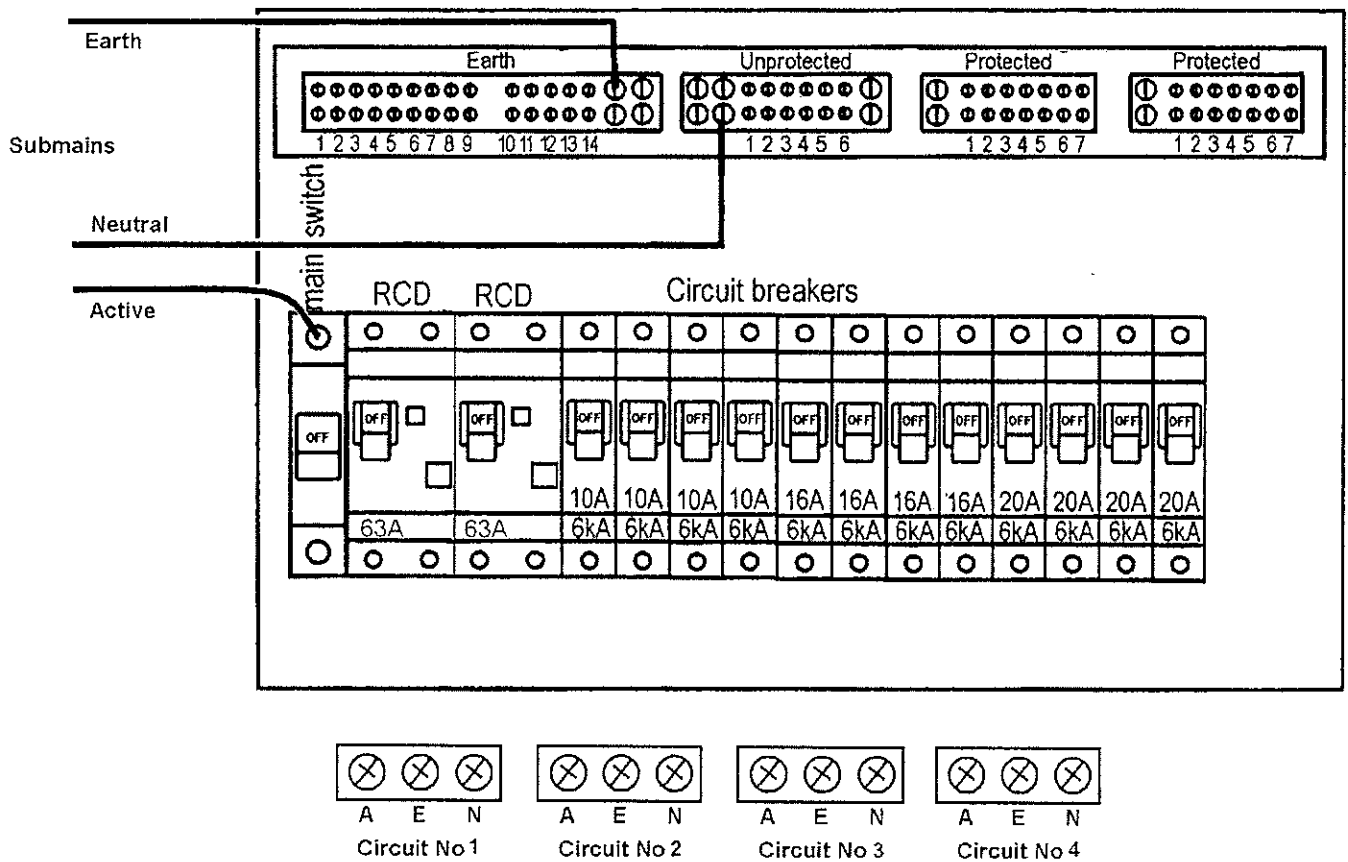

SECTION D – (Cont'd)

QUESTION 2. (2 Marks)

A 16A circuit breaker with the tripping characteristic shown below is protecting a 230V circuit wired with 2.5 mm², multi-core, V90, Cu cable. The circuit is supplying socket outlets. The fault loop impedance was measured at the furthestmost point on the circuit using a fault loop impedance instrument. The result was 1.7 Ω at ambient conditions (i.e., 40°C). Answer the following questions showing all working, and support your answer/s by marking the characteristic curve Figure 2 below.

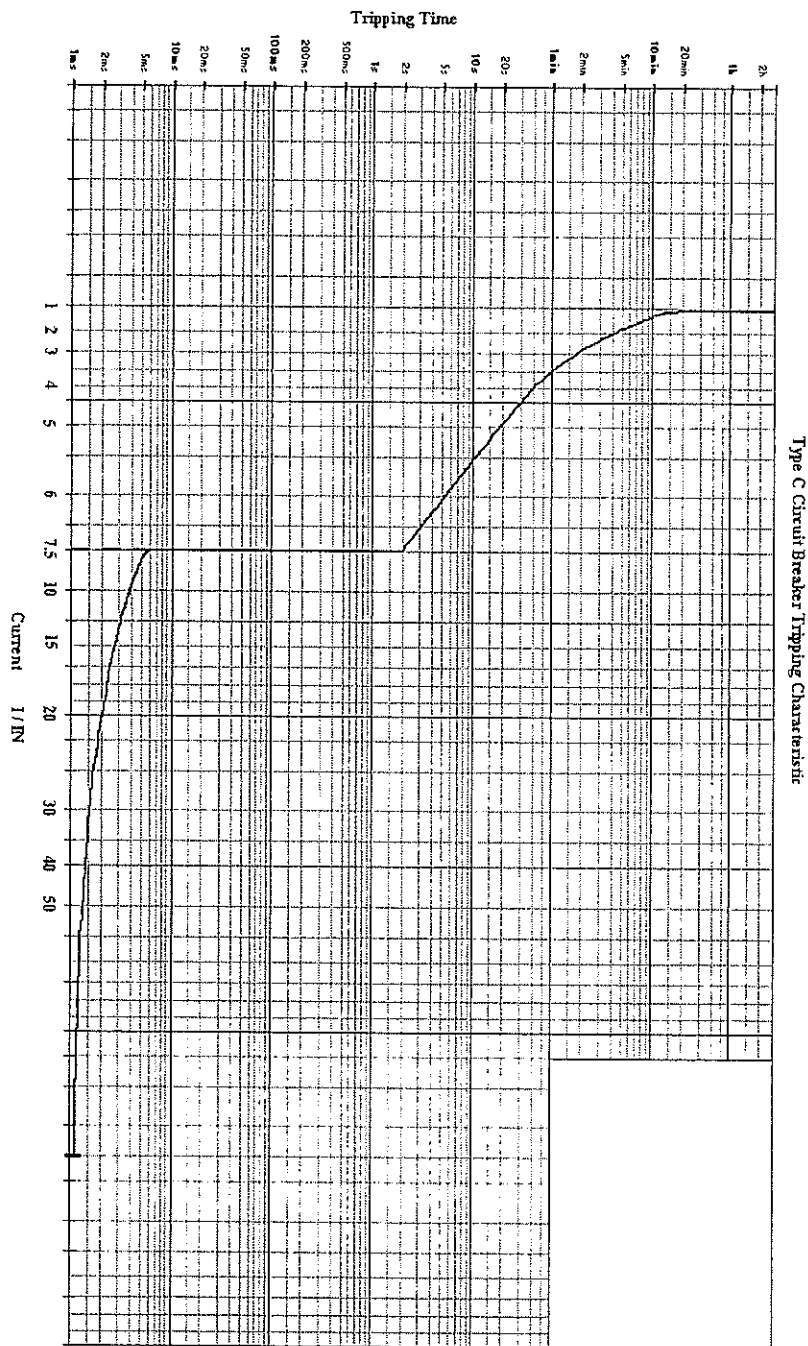

Figure 2

SECTION D – (Cont'd)

QUESTION 2. (Cont'd)

a) Calculate the fault current for an active to earth fault at the furthestmost point.

.....
.....
.....
.....

b) Determine the circuit breaker disconnection time considering the fault condition indicated above.

.....
.....
.....

c) Does the circuit meet AS/NZS 3000:2007 requirements for fault loop impedance?
YES/NO

Why?.....
.....
.....
.....

d) Determine the maximum allowable resistance of the protective earth conductor.

.....
.....
.....
.....

SECTION D – (Cont'd)

QUESTION 3. (4 Marks)

The following diagram shows how the switchboard has been prepared, ready for testing the insulation resistance between active and earth of a single-phase power circuit. The circuit is protected by a 32A separate RCD and a 16A MCB. Identify the correct setting for the insulation resistance tester by placing an "X" in the appropriate box and answer the four following questions. The board is electrically isolated.

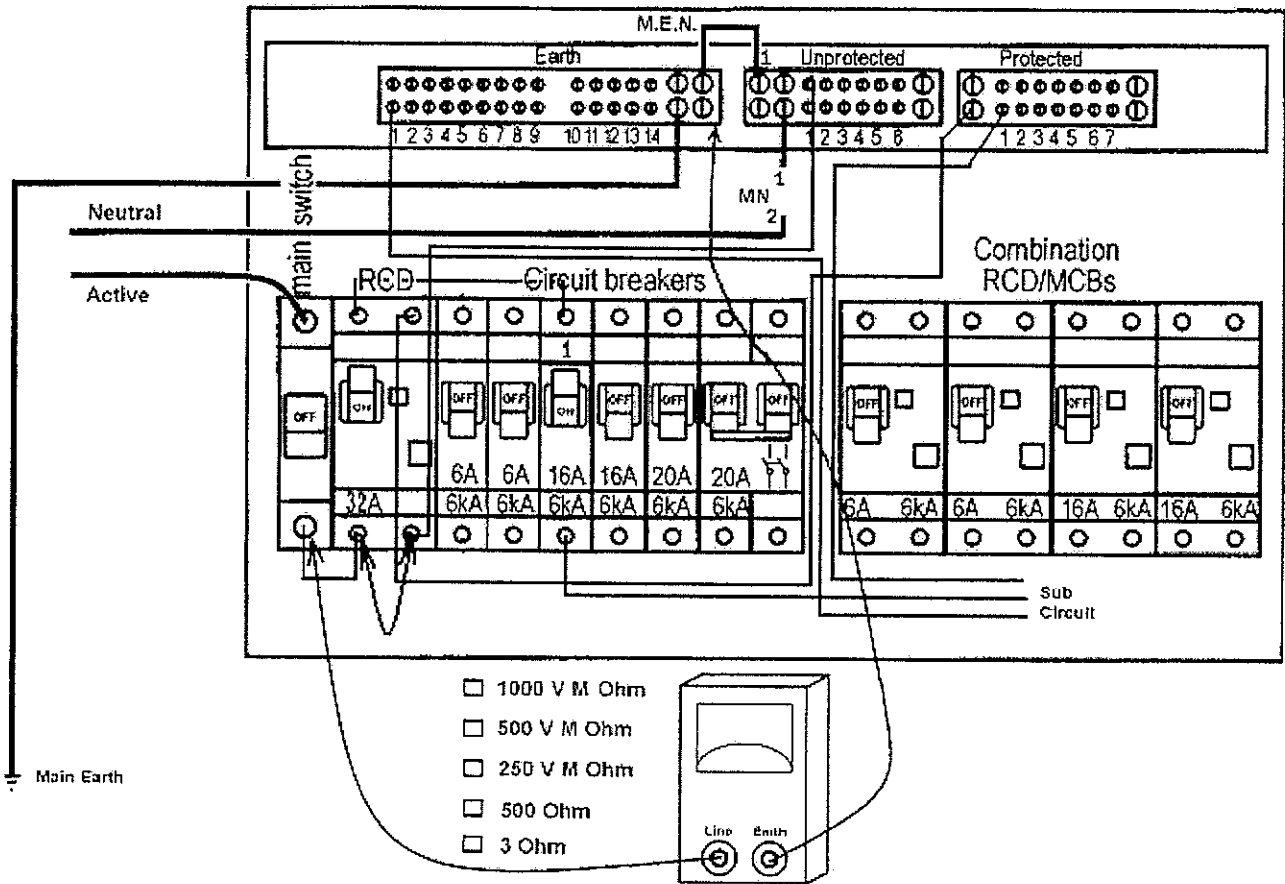

Circle the correct answer

The MEN link (2) should be:

- a) Connected to position 1 as shown
- b) Disconnected

A reading of ∞ M Ω would indicate:

- a) Satisfactory result
- b) Unsatisfactory result

The main neutral should be:

- a) Disconnected as shown
- b) Connected to Position 1

The leads of the testing device are:

- a) Correctly connected
- b) Incorrectly connected

SECTION D – (Cont'd)

QUESTION 4. (3 Marks)

Answer the question and complete the following table using the diagram below.

A correct circuit connection test is being performed. Identify the correct setting for the test equipment by placing an "X" in the appropriate box. The board is electrically isolated.

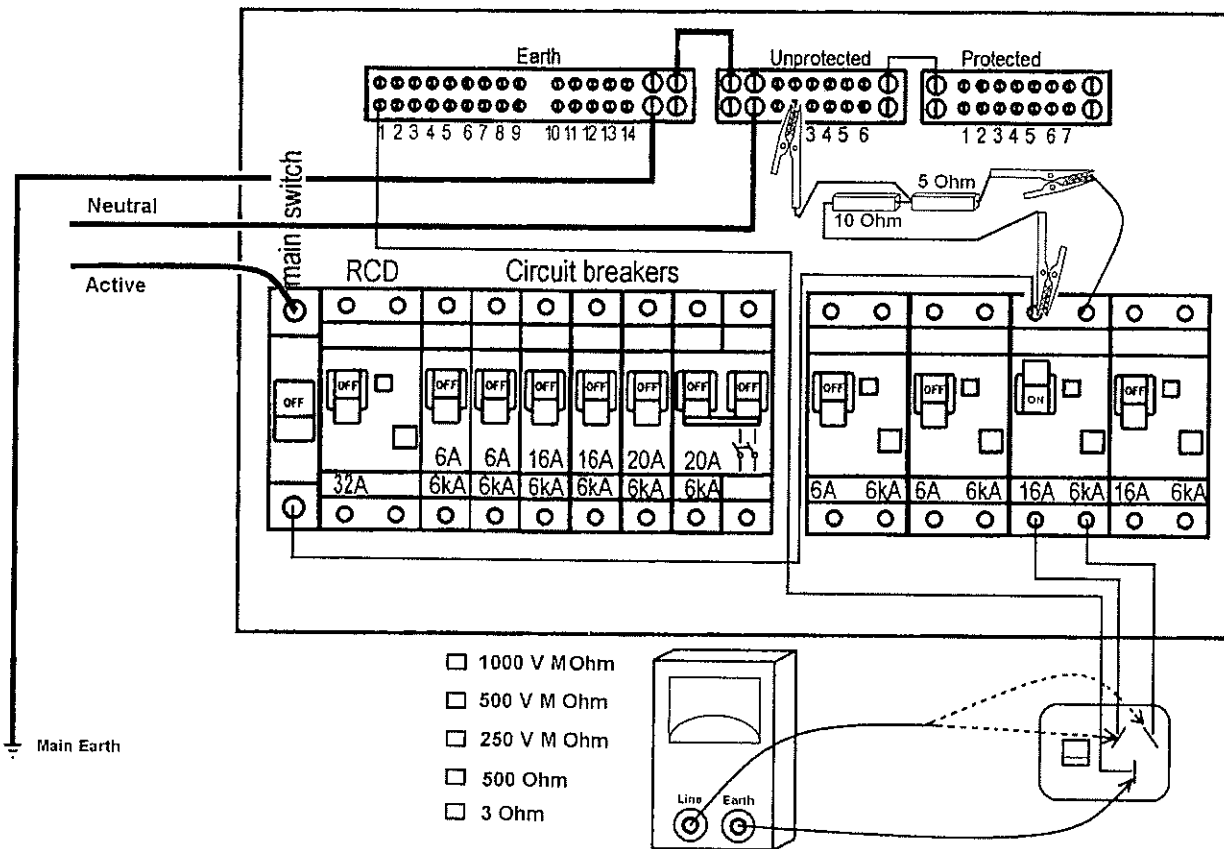

Assuming the socket outlet is correctly connected, complete the table:

Test Equipment Connection	Reading
Active to Earth with socket outlet switched on	
Active to Earth with socket outlet switch off	
Neutral to Earth with socket outlet switch off	
Neutral to Earth with socket outlet switch on	

Identify any fault indicated by a reading of approximately 15 Ω between the neutral and earth socket measured at the socket outlet:

.....

SECTION D – (Cont'd)

QUESTION 5. (3 Marks)

Provide a brief written explanation highlighting why each fault is potentially dangerous.

Fault	Answer
Insulation resistance too low	<hr/> <hr/> <hr/> <hr/> <hr/> <hr/> <hr/> <hr/>
Socket outlet reversed active neutral polarity	<hr/> <hr/> <hr/> <hr/> <hr/> <hr/> <hr/> <hr/>
Intermix of two lighting circuit neutrals	<hr/> <hr/> <hr/> <hr/> <hr/> <hr/> <hr/> <hr/>

(END OF SECTION D)

Equation Data Sheet

$$\cos \phi = \frac{P}{S}$$

$$\cos \phi = \frac{R}{Z}$$

$$S = \sqrt{P^2 + Q^2}$$

$$S = VI$$

$$P = VI \cos \phi$$

$$Q = VI \sin \phi$$

$$f_o = \frac{1}{2\pi\sqrt{LC}}$$

$$V_L = \sqrt{3}V_p$$

$$I_L = \sqrt{3}I_p$$

$$S = \sqrt{3}V_L I_L$$

$$P = \sqrt{3}V_L I_L \cos \phi$$

$$Q = \sqrt{3}V_L I_L \sin \phi$$

$$\tan \phi = \sqrt{3} \left(\frac{W_2 - W_1}{W_2 + W_1} \right)$$

$$Q = mC\Delta t$$

$$V' = 4.44\Phi f N$$

$$\frac{V_1}{V_2} = \frac{N_1}{N_2}$$

$$\frac{I_2}{I_1} = \frac{N_1}{N_2}$$

$$N_{syn} = \frac{120f}{P}$$

$$s\% = \frac{(n_{syn} - n)}{n_{syn}} \times \frac{100}{1}$$

$$f_r = \frac{s\% \times f}{100}$$

$$V_{reg} \% = \frac{(V_{NL} - V_{FL})}{V_{FL}} \times \frac{100}{1}$$

$$V_{reg} \% = \frac{(V_{NL} - V_{FL})}{V_{NL}} \times \frac{100}{1}$$

$$T = \frac{\Phi ZIP}{2\pi\alpha}$$

$$I_{ST} = \frac{1}{3} \times I_{DOL}$$

$$T_{ST} = \frac{1}{3} \times T_{DOL}$$

$$I_{ST} = \frac{V_{ST}}{V} \times I_{DOL}$$

$$T_{ST} = \left(\frac{V_{ST}}{V} \right)^2 \times T_{DOL}$$

$$I_{motor st} = \frac{\%TAP}{100} \times I_{DOL}$$

$$I_{line st} = \left(\frac{\%TAP}{100} \right)^2 \times I_{DOL}$$

$$E = \frac{\Phi_v}{A}$$

$$E = \frac{I}{d^2}$$

$$\eta_v = \frac{\Phi_v}{P}$$

$$V_L = 0.45V_{ac}$$

$$V_L = 0.9V_{ac}$$

$$V_L = 1.17V_{phase}$$

$$V_L = 1.35V_{line}$$

$$PRV = \sqrt{2}V_{ac}$$

$$PRV = 2\sqrt{2}V_{ac}$$

$$PRV = 2.45V_{ac}$$

$$V_{ripple} = \sqrt{2}V_{ac}$$

$$V_{ripple} = 0.707V_{phase}$$

$$V_{ripple} = 0.1895V_{line}$$

Equation – Data Sheet

$$Q = It$$

$$v = \frac{s}{t}$$

$$a = \frac{\Delta v}{t}$$

$$F = ma$$

$$W = Fs$$

$$W = mgh$$

$$W = Pt$$

$$\eta\% = \frac{\text{output}}{\text{input}} \times \frac{100}{1}$$

$$I = \frac{V}{R}$$

$$P = VI$$

$$P = I^2R$$

$$P = \frac{V^2}{R}$$

$$R_2 = \frac{R_1 A_1 l_2}{A_2 l_1}$$

$$R_h = R_c(1 + \alpha \Delta t)$$

$$R = \frac{\rho l}{A}$$

$$R_T = R_1 + R_2 + R_3$$

$$V_T = V_1 + V_2 + V_3$$

$$\frac{1}{R_T} = \frac{1}{R_1} + \frac{1}{R_2} + \frac{1}{R_3}$$

$$I_T = I_1 + I_2 + I_3$$

$$V_2 = V_T \frac{R_2}{R_1 + R_2}$$

$$I_2 = I_T \frac{R_1}{R_1 + R_2}$$

$$R_x = \frac{R_A R}{R_B}$$

$$C = \frac{Q}{V}$$

$$\tau = RC$$

$$\frac{1}{C_T} = \frac{1}{C_1} + \frac{1}{C_2} + \frac{1}{C_3}$$

$$C_T = C_1 + C_2 + C_3$$

$$C = \frac{A \epsilon_0 \epsilon_r}{d}$$

$$F_m = IN$$

$$H = \frac{F_m}{l}$$

$$B = \frac{\Phi}{A}$$

$$\Phi = \frac{F_m}{S}$$

$$S = \frac{l}{\mu_0 \mu_r A}$$

$$V = N \frac{\Delta \Phi}{\Delta t}$$

$$e = Blv$$

$$L = \frac{\mu_0 \mu_r AN^2}{l}$$

$$L = N \frac{\Delta \Phi}{\Delta I}$$

$$V = L \frac{\Delta I}{\Delta t}$$

$$\tau = \frac{L}{R}$$

$$F = Bil$$

$$T = Fr$$

$$E_g = \frac{\Phi Z n P}{60 a}$$

$$P = \frac{2\pi n T}{60}$$

$$t = \frac{1}{f}$$

$$f = \frac{np}{120}$$

$$V = 0.707 V_{\max}$$

$$I = 0.707 I_{\max}$$

$$V_{\text{ave}} = 0.637 V_{\max}$$

$$I_{\text{ave}} = 0.637 I_{\max}$$

$$v = V_{\max} \sin \phi$$

$$i = I_{\max} \sin \phi$$

$$I = \frac{V}{Z}$$

$$Z = \sqrt{R^2 + (X_L - X_C)^2}$$

$$X_L = 2\pi f L$$

$$X_C = \frac{1}{2\pi f C}$$

Name:.....

College:.....

ANSWER SHEET – Section A (Multi-choice Questions)

Module - 6077AC

Examination Date: 23 June 2010

Instructions:

- Enter your name and college on this sheet.
- Place an **X** in box of your choice. If you make a mistake- circle your answer **(X)** and choose again.
- For your convenience you can remove this page while you answer Section A. **Remember to re-attach it** to the paper when you hand it in.

Question	a	b	c	d
1				
2				
3				
4				
5				
6				
7				
8				
9				
10				
11				
12				
13				
14				
15				
Totals				
Total Correct Section A				

Total Marks Section A: /15

END OF EXAMINATION

MARKING GUIDE

Module/Unit No: 6077AC

Module/Unit Name: Electrical Systems
Safety-Capstone Assessment

Exam Date: 23/6/10

Number of Pages: 29 (including this page)



Family Name

Other name.....

Centre

Signature

23rd June 2010

6077AC (Electrical System Safety)

Time allowed – Three hours plus Ten minutes reading time

28 Pages in this Question Booklet

All Questions to be attempted

TOTAL MARKS AVAILABLE = 100

Section	Possible mark	Actual mark
A	15	
B	20	
C	45	
D	20	
Total	100	

Aids to be supplied by college

- None

Marking Guide

Aids to be supplied by student

- Australian/New Zealand Wiring rules AS/NZS 3000:2007 incorporating amendment 1
- Australian/New Zealand Electrical Installations – Selection of Cables AS/NZS 3008.1.1:1998 or 2009
- Service and Installation Rules of NSW incorporating Amendment 2
- AS/NZS 3017:2007 Electrical Installation Testing Guidelines
- Students own marginal notes, indexing and formal amendments may be included in the above regulation books.
- Pen, pencil, eraser, rule, calculator

Instructions to Student

- **Mobile phones are to be turned off and removed from your person.** You cannot access a mobile phone during this test.
- All questions to be answered in the space provided on this **examination paper**. Answers to Section A – multi-choice questions, are to be answered on the sheet attached to this examination paper.
- You are not to use any other reference book in this examination.
- The whole of this paper is to be handed to the Supervisor upon completion.

Aids permitted where indicated:

Standard Dictionaries	Bilingual Dictionaries	Technical Dictionaries	Programmable Calculators	Non-programmable Calculators
No	No	No	No	Yes

SECTION A – (15 Marks)

INSTRUCTIONS: Select the best answer for the following statements and place an 'X' in the appropriate box on the Answer Sheet attached to this examination paper. Each correct answer is worth ONE (1) mark.

QUESTION 1. (1 Mark)

It is required to earth the structural metalwork forming the frame of a dwelling in a domestic installation. How can this connection be made?

- (a) 4mm² bonding conductor provided that the resistance between the earth bar and any part required to be earthed does not exceed 0.5 Ω
- (b) 2.5mm² protective earthing conductor provided that the resistance between the earth bar and any part required to be earthed does not exceed 0.5 Ω
- (c) appropriately sized protective earthing conductor at one point of the metalwork provided that the resistance between the earth bar and any part required to be earthed does not exceed 0.5 Ω
- (d) appropriately sized bonding conductor at one point of the metalwork provided that the resistance between the earth bar and any part required to be earthed does not exceed 0.5Ω

QUESTION 2. (1 Mark)

What is the minimum allowable load current rating of a separate RCD installed in a domestic installation? The RCD is protecting two (2) final sub circuits each with a 10A CB. The total maximum demand of the two circuits is 9A.

- (a) 20A
- (b) 10A
- (c) 9A
- (d) sum of individual circuit breakers

QUESTION 3. (1 Mark)

From AS/NZS 3000:2007, the maximum permissible voltage drop between the point of supply and the main switch on a 230V main switch board with several final sub-circuits attached is:

- (a) 5% U_o
- (b) 11.5 V
- (c) 5% of the voltage measured at the MSB
- (d) not prescribed

SECTION A – (Cont'd)

QUESTION 4. (1 Mark)

Under short circuit conditions, what is the maximum permissible sheath temperature for a 25mm² PVC (V90) Cu single core cable?

- (a) 160° C
- (b) 90° C
- (c) 75° C
- (d) 250° C

QUESTION 5. (1 Mark)

What is the standard minimum depth of laying an enclosed service mains cable underground?

- (a) 300 mm
- (b) 500 mm
- (c) 600 mm
- (d) 1000 mm

QUESTION 6. (1 Mark)

The colour code that distinguishes a dry chemical powder fire extinguisher is

- (a) red with white stripe
- (b) red with black stripe
- (c) blue
- (d) red

QUESTION 7. (1 Mark)

What is the maximum allowable earth leakage current for a 230V class I appliance with sheathed heating elements?

- (a) 30 mA
- (b) 0 mA
- (c) 0.22 mA
- (d) 23 mA

SECTION A – (Cont'd)

QUESTION 8. (1 Mark)

The sign shown in Figure 1 is an example of a:

- (a) prohibition sign
- (b) mandatory sign
- (c) restriction sign
- (d) warning sign



Figure 1

QUESTION 9. (1 Mark)

Automatic disconnection of the supply is required to limit the harmful effects of internal switchboard arcing. Protection should initiate at a current less than:

- (a) 20% of three phase prospective fault level
- (b) 20% of single phase prospective fault level
- (c) 60% of single phase prospective fault level
- (d) 30% of three phase prospective fault level

QUESTION 10. (1 Mark)

What is the maximum allowable resistance of an equipotential bonding conductor?

- (a) not specified
- (b) 2Ω
- (c) 1Ω
- (d) 0.5Ω

QUESTION 11. (1 Mark)

With which standard must equipment installed in a hazardous area comply?

- (a) AS/NZS 2381.1
- (b) AS2209
- (c) AS3017
- (d) all of the above

SECTION A – (Cont'd)

QUESTION 12. (1 Mark)

After conducting a risk assessment what is the first choice of action taken to reduce risk is:

- (a) elimination
- (b) PPE
- (c) substitution
- (d) administration

QUESTION 13. (1 Mark)

A Certificate of compliance of electrical work must be finalised when an electrical installation is tested. The section pertaining to testing should be completed by:

- (a) the consumer
- (b) the holder of the electrical contracting licence
- (c) the qualified supervisor (electrical) who completed the test
- (d) a registered installation inspector

QUESTION 14. (1 Mark)

The maximum disconnection time specified for protection against indirect contact for a final sub circuit protecting a lighting circuit is

- (a) unspecified
- (b) 0.1 s
- (c) 0.4 s
- (d) 5s

QUESTION 15. (1 Mark)

Every conductor shall have a current-carrying capacity that must be

- (a) less than the current for which the circuit is designed (IB)
- (b) not less than the circuit breaker nominal rating (IN)
- (c) not greater than the current to be carried by the conductor
- (d) based on an ambient air temperature of 40°C

(End of Section A)

SECTION B – (20 Marks)

INSTRUCTIONS: Blank spaces in the following statements represent omissions. Write the appropriate word, words or information in the numbered spaces provided. Each question is worth TWO (2) marks. 1 mark is deducted for each incorrect or missing reference. 2 marks are deducted for each incorrect answer

- Use AS/NZS 3000:2007 to best answer each question.
- Include AS/NZS 3000 references where required.

QUESTION 1.

What distance is required between recessed halogen lamp?

200mm

AS/NZS 3000 Reference ()

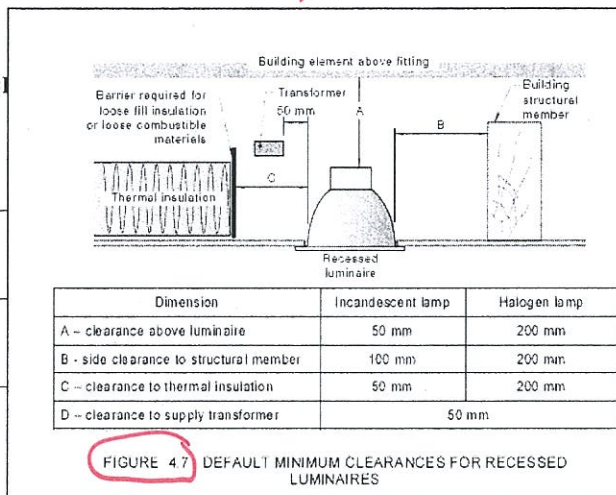

QUESTION 2.

Is it necessary to provide an equipotential contact with the ground and accessible to the public for a type that is in a switchboard?

YES

AS/NZS 3000 Reference ()

5.6.2.2 b

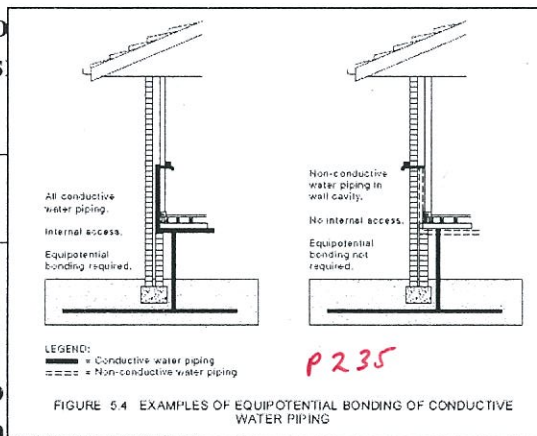

QUESTION 3.

What is the minimum size and color of a 100kV conductor that is supplied by unprotected consumers mains?

100kV

5.3.5.3 → GREEN/YELLOW/SAME SIZE AS NEUTRAL - 5.3.5.2

5.3.5.5 Unprotected consumers mains
 Exposed conductive parts associated with consumers mains not provided with short-circuit protection on the supply side shall be earthed by a conductor with a current-carrying capacity not less than that of the main neutral conductor.
 This conductor shall be connected to—
 (a) the main neutral conductor or bar; or
 (b) the main earthing terminal/connection or bar, in which case, in accordance with Clause 5.3.5.2, the cross-sectional area of the MEN connection shall be not less than that of the main neutral conductor.

5.3.5.2 Size
 The MEN connection shall be a conductor complying with Clause 5.3.2 and have a cross-sectional area capable of carrying the maximum current that it may be required to carry under short-circuit conditions.
 The minimum size shall be not less than, but need not exceed, the current-carrying capacity of the main neutral conductor.
 Exception: The minimum size of the MEN connection need not exceed that of the main earthing conductor where—
 (a) short-circuit protection is provided on the supply side of the consumers mains; or
 (b) the earthing of an enclosure containing consumers mains not provided with short-circuit protection on the supply side is made by connection directly to the neutral bar or link in accordance with Clause 5.3.5.5; or
 (c) double insulation of the consumers mains conductors is maintained up to the supply terminal/s of the service protective device/s, and short-circuit protection is provided by such device/s.
 NOTE: An electricity distributor's upstream service protective device may provide short-circuit protection of consumers mains.
5.3.5.3 Identification
 Where the MEN connection is insulated, the insulation shall be coloured green or in a combination of green and yellow, in accordance with Clause 3.8.

SECTION B – (Cont'd)

QUESTION 4.

What is the maximum length of the cable for a 65V under wet conditions?

~~450~~ 350ms

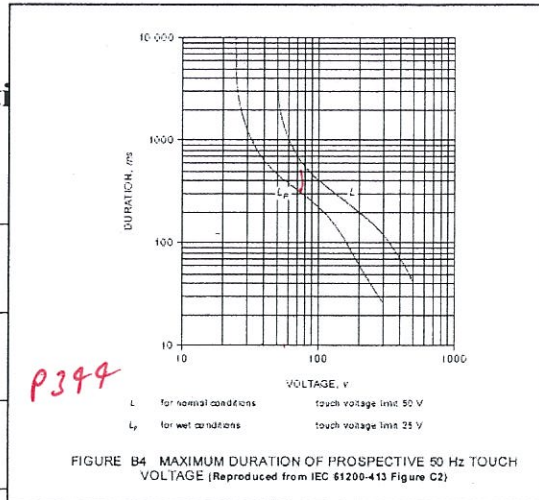

potential of

AS/NZS 3000 Reference (

QUESTION 5.

Is it permissible to use bare copper electrodes?

YES

TABLE 5.2
ACCEPTABLE EARTH ELECTRODES

Material	Surface treatment	Minimum dimensions	Minimum surface treatment thickness
Vertical electrodes			
Steel	Copper clad	Ø12 mm circular rod	250 µm
	Copper plated	Ø12 mm circular rod	250 µm
	Stainless (clad)	Ø12 mm circular rod	600 µm
	Hot dipped galvanised	Ø16 mm circular rod	63 µm
	Hot dipped galvanised	Section with minimum cross-sectional area of 200 mm ² and with no part less than 3 mm thick	63 µm
Non-ferrous (excluding aluminium)	Solid	12 mm	N/A
Horizontal (strip) electrodes			
Copper rod	Solid	Ø7 mm circular	N/A
Copper strip	Solid	25 mm x 1.6 mm	N/A
Copper pipe		Ø15 mm circular x 2.45 mm wall thickness	N/A
Copper cable	Bare	35 mm ²	N/A
Steel pipe	Hot dipped galvanised	Ø20 mm	63µm
Steel strip	Hot dipped galvanised	40 mm x 3 mm	63µm

Handwritten 'P220' is below the table.

AS/NZS 3000 Reference (T5.2

QUESTION 6.

What are the specific requirements (in addition to those in zone 1) for electrical equipment installed within zone 2 of a sink having a capacity of 100 litres?

AS

IPX NOT REQUIRED

TABLE 6.1
GUIDANCE ON THE SELECTION AND INSTALLATION OF ELECTRICAL EQUIPMENT FOR BATHS, SHOWERS AND OTHER FIXED WATER CONTAINERS

Equipment	Zone 0	Zone 1	Zone 2	Zone 3
Clause 6.2.4.2 Socket-outlets	Not permitted	Not permitted	(a) a shower outlet; or (b) RCD-protected and in a cupboard (no specific IP rating).	(a) <0.3 m not permitted (b) ≥0.3 m no IP rating* but shall have— (i) RCD protection; or (ii) separated supply; or (iii) SELV or PELV supply
Clause 6.2.4.3 Switches and accessories	Not permitted	Same as Zone 2	<0.3 m not permitted ≥0.3 m IPX4*	<0.3 m not permitted ≥0.3 m no IP rating*
Clause 6.2.4.4 Luminaires	IPX7 and specifically for use and SELV or PELV supply	IPX4*	IPX4*; or Class II construction (double or reinforced insulation); or SELV or PELV; or recessed into ceiling	No IP rating*
Clause 6.2.4.5 Other	IPX7 and specifically for use and SELV or PELV supply	IPX4*	IPX4*; or recessed into ceiling	No IP rating*
Clause 6.2.4.6 Switchboards	Not permitted	Not permitted	Not permitted	Not permitted

*Degree of protection IPX5 required in communal bath/showers.

Handwritten 'P299' is above the table.

installed

AS/NZS 3000 Reference (

6.2.4.2b

QUESTION 7.

What is the minimum rating of a circuit breaker for a sub-circuit supplying a 12kW range?

32A MIN

final

AS/NZS 3000 Ref

TABLE C4
MAXIMUM DEMAND—DOMESTIC COOKING APPLIANCES

Appliance full-load energy rating per phase	Assessed maximum demand
Not greater than 5000 W	16 A
Greater than 5000 W but not greater than 8000 W	23 A
Greater than 8000 W but not greater than 10000 W	25 A
Greater than 10000 W but not greater than 13000 W	32 A
Greater than 13000 W	40 A

Handwritten 'P373' is above the table.

12kW MAX
I = $\frac{12000}{230} = 52A$

SECTION B – (Cont'd)

QUESTION 8.

Is the following item of electrical smoke control equipment? Air handling systems intended to exhaust and control the spread of fire and smoke.

_____ YES _____

7.2.1.2 Fire- and smoke-control equipment P 284

For the purposes of this Clause 7.2, fire- and smoke-control equipment shall be deemed to include the following items and electrical equipment that are essential to their safe operation:

- (a) Fire hydrant booster pumps.
- (b) Pumps for automatic sprinkler systems, water spray or deluge systems and similar fire-extinguishing systems.
- (c) Pumps for fire-hose reels, where such hose reels form the sole means of fire protection, i.e. where fire hydrants and automatic fire-sprinkler systems are not installed.
- (d) Fire detection and alarm systems.
- (e) Air-handling systems intended to exhaust and control the spread of fire and smoke.

and the

AS/NZS 3000 Reference (_____)

QUESTION 9.

List five criteria that need to be addressed when designing an electrical installation.

1.6 DESIGN OF AN ELECTRICAL INSTALLATION P 50, 51

1.6.1 General

An electrical installation shall be designed to—

- (a) protect persons, livestock and property from harmful effects;
- (b) function correctly as intended;
- (c) connect, operate safely and be compatible with the electricity distribution system, or other source of supply, to which the electrical installation is to be connected;
- (d) minimize inconvenience in the event of a fault; and
- (e) facilitate safe operation, inspection, testing and maintenance.

AS/NZS 3000 Reference (1.6.1)

QUESTION 10.

Wiring systems associated with fire and smoke control equipment, evacuation equipment and lifts, shall be capable of maintaining an adequate supply to such equipment when:

7.2.7 Wiring systems P 291

7.2.7.1 General

Wiring systems associated with safety services shall be capable of maintaining an adequate supply to such equipment when exposed to fire.

AS/NZS 3000 Reference (7.2.7.1) OR 7.2.7.1

(End of Section B)

SECTION C – (45 Marks)

INSTRUCTIONS: This section involves calculations. Show all necessary working in the space provided, marks will be awarded accordingly. Answers are to be highlighted or underlined.

QUESTION 1. (4 Marks)

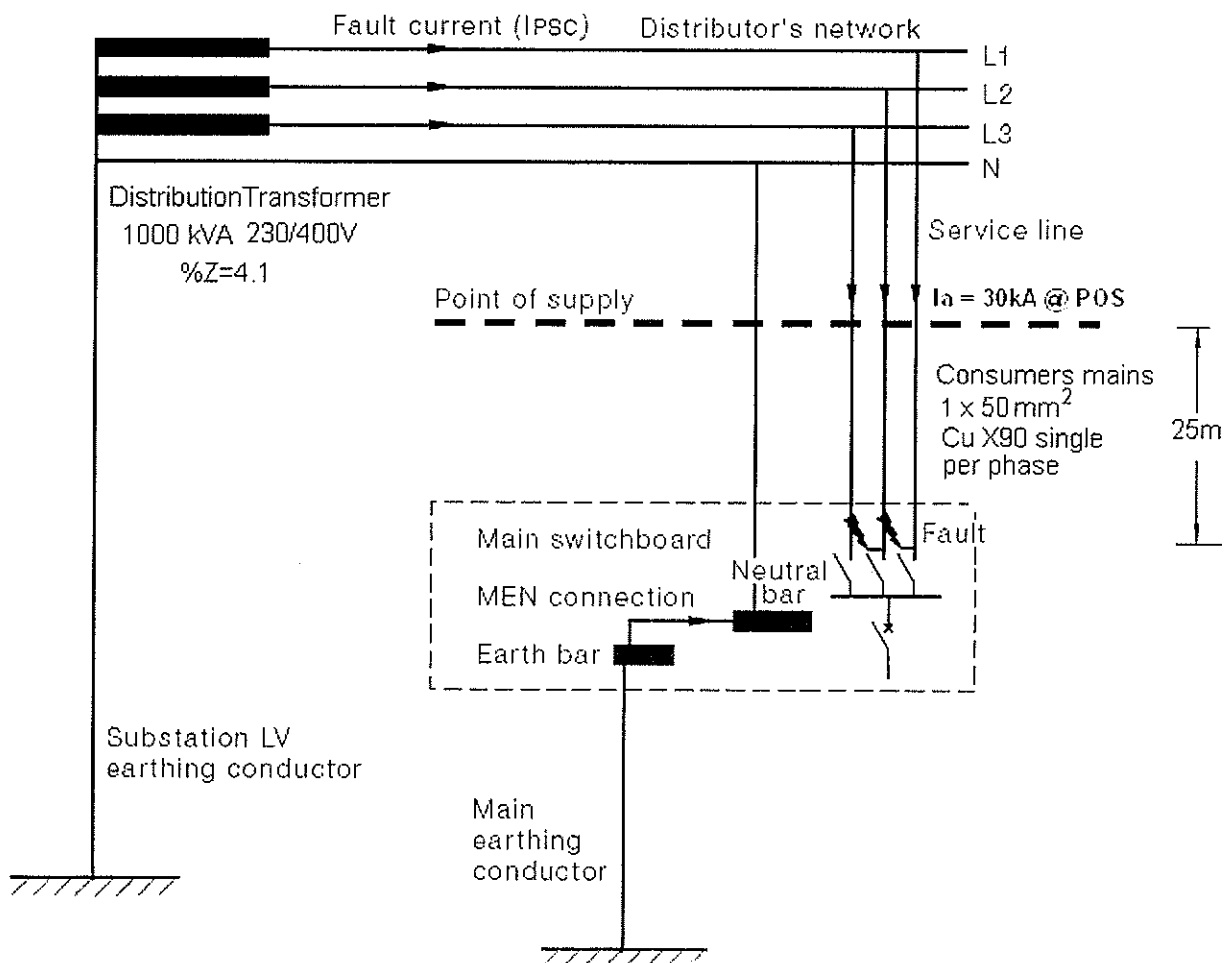

Figure 1

Parts a to d relate to figure 1

a) Determine the phase impedance of the distribution transformer.

1 Mark	$I_{fl} = \frac{S}{\sqrt{3}U}$ $= \frac{1,000,000}{693}$ $= 1,443 \text{ A}$	$I_{sc} = \frac{100 I_{fl}}{\%z}$ $= \frac{144,300}{4.1}$ $= 35.2 \text{ kA}$	$Z_{ph} = \frac{U_{ph}}{I_{sc}}$ $= \frac{230}{35,200}$ $= 6.53 \text{ m}\Omega$ <p style="margin-left: 20px;"><i>0.00653 \Omega</i></p>	OR	$Z_{ph} = \frac{\%z U_L^2}{100S}$ $= \frac{4.1 \times 400^2}{100 \times 1,000 \times 10^3}$ $= 6.56 \text{ m}\Omega$
---------------	--	---	--	----	--

SECTION C – (Cont'd)

- b) Determine the distributor's network system impedance, for a 3 ϕ prospective fault current of 30kA at the point of supply

1 Mark

$$Z_{sys} = \frac{U_{ph}}{I_{psc}}$$
$$= \frac{230}{30,000}$$
$$= 7.67 \text{ m}\Omega$$

0.00766\Omega

- c) Assuming a bolted 3 ϕ fault at the M.S.B. as indicated on the diagram, calculate the maximum prospective short circuit current. The Consumer mains consist of 1 x 50 mm² Cu X90 SDI per phase with a route length of 25m. The maximum fault level at the Point of supply is 30kA, as indicated on the diagram. (AS3008 has appropriate tables for conductor resistance – ignore reactance. Assume conductor initial temperature is 45 deg)

1 Mark

$$Z_{sys} = \frac{U_{ph}}{I_{psc}}$$
$$= \frac{230}{30,000}$$
$$= 7.67 \text{ m}\Omega$$
$$I_{sc} = \frac{U_{ph}}{Z_{total}}$$
$$= \frac{230}{0.00767 + 0.0107}$$
$$= 12,520 \text{ A}$$
$$= 12.6 \text{ kA}$$

AS3008 Table 34 @ 45°
25m x 50mm² X90 Cu
 $= \frac{0.426 \times 25}{1000}$
 $= 10.7 \text{ m}\Omega$
0.0107\Omega

- d) From the list below choose a suitable interrupting capacity for protective devices installed at the main switch board *FOR COUNCIL FUSE*

3kA

4.5kA

8kA

10kA

15kA

Correct answer

1 Mark

SECTION C – (Cont'd)

QUESTION 2. (4 Marks)

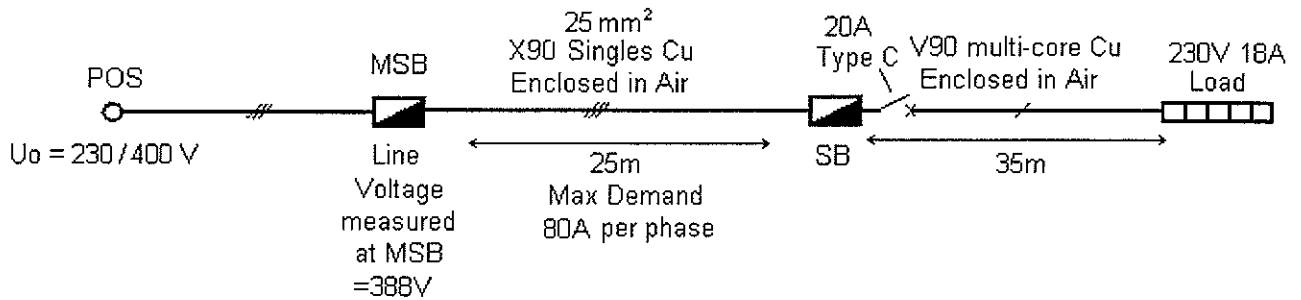

Based on VOLTAGE DROP, determine the minimum size cable for the SINGLE PHASE final sub circuit shown above.

AS3008 Table 41 25mm ² Cu X90 Vc = 1.601 mV/Am	$V_d = \frac{V_c L I}{1000}$ $= \frac{1.601 \times 25 \times 80}{1000}$ $= 3.2V$	Total Vd to MSB 400-388= 12V Total Vd to SB = 12 + 3.2 = 15.2V Convert to 1 ϕ Vd $= \frac{15.2}{\sqrt{3}}$ $= 8.77V$	5% \times 230 = 11.5V 11.5-8.77=2.73V $V_c = \frac{1000 V_d}{L I}$ $= \frac{1000 \times 2.73}{35 \times 18}$ $= 4.3 \text{ mV/Am}$	Convert 4.3 to 3 ϕ Vc 4.3 \times 0.866 = 3.72mV/Am AS3008 Table 42 V90 Cu Multicore Minimum cable size 16mm (2.43mV/Am)
	1 Mark	1 Mark	1 Mark	1 Mark

QUESTION 3. (4 Marks)

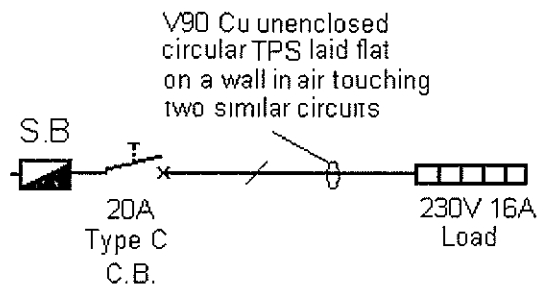

Cable installation method

Derating Table 22 Item 3 Column 6 Derating factor 0.79	1 Mark	... CITY determine the minimum size cable for n above.
Cable minimum CCC = 20 $\frac{20}{0.79}$ $= 25.3A$	1 Mark	
From AS3008 Table 3.1 Item 12 Table 10 Column 5	1 Mark	
Minimum cable size = 2.5mm (26A)	1 Mark	

SECTION C – (Cont'd)

QUESTION 4. (4 Marks)

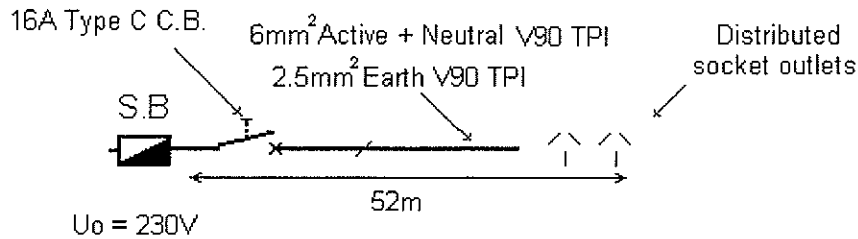

Based on FAULT LOOP IMPEDANCE determine if the final sub circuit satisfies the requirements of AS/NZS 3000:2007 – show all references and working

AS3000.2007 Disconnection time 0.4s Unable to use Table B1	From AS3000.2007 Appendix B5.2.2 $\rho=0.0225$ Appendix B4.5 $I_a=16 \times 7.5$ $I_a=120 A$	$L_{max} = 0.8 U_o S_{ph} S_{pe}$ $I_{ap}(S_{ph} + S_{pe})$ $L_{max} = \frac{0.8 \times 230 \times 6 \times 2.5}{120 \times 0.0225 \times 8.5}$ $L_{max} = \frac{2760}{22.95}$ $L_{max} = 120m$	Circuit Length = 52m $L_{max} = 120m$ $52 < 120$ Circuit satisfies the requirements of fault loop impedance.
1 Mark	1 Mark	1 Mark	1 Mark

QUESTION 5. (4 Marks)

Determine the maximum demand for the following 230V SINGLE Domestic Installation

- 36 x 50W down lights A_i
- 18 x double 10A socket outlets A_i
- 4 x single 10A socket outlets B_i
- 1 x 8 kW 230V cooktop C
- 1 x 3.6 kW 230V oven C
- 1 x 15A socket outlet (general purpose) B_{ii}
- 1 x permanently connected 230V 8A split air conditioner
- 4 x permanently connected 115W ceiling fans
- 2 x 10A socket outlets installed $> 2.4m$ for 65W exhaust fans A_i
- 1 x 400 litre Solar hot water with a 20A quick recovery boost element

SECTION C – (Cont'd)

Deduct 1 mark each incorrect line

* CAN USE IN D

Load Group	Load / Qty	Calculation	Maximum Demand
Ai	36 lights 4 c fans 2 ex fans	42 points 3A (first 20) + 2A (next 20 or part thereof) + 2A (next 20 or part thereof)	7A
Aii			
Bi	18 Dbl 10A 18 x 2=36 4 Single 10A 1 x 8A AC*	41 points 10A (first 20) 5A (next 20 or part thereof) 5A (next 20 or part thereof)*	20A
Bii	1 x 15A socket outlet	1 point 10A	10A
Biii			
C	8kW CT 3.6kW Oven	11.6 kW total (50% connected load) $I = \frac{11600}{230} \times 0.5$ =25.2A	25.2A
D		$75 \times 8 = 6A$	6A
E			
F	20A Quick recovery element	20A (FLC) $I=20A$ $20 \times 230 = 4600$ $\frac{4600}{400} = 11.5$	20A
G			
Maximum Demand			83.1A ✓

SECTION C – (Cont'd)

QUESTION 6. (7 Marks)

Determine the maximum demand for the following 230/400V three-phase MULTIPLE domestic installation, consisting of twenty five (25) individual living units.

Electrical equipment associated with each individual (1) unit:

22 x 50W down lights

12 x double 10A socket outlets

3 x single 10A socket outlets

1 x 10A socket outlet for 230V air conditioner

2 x permanently connected 120W ceiling fans

In addition to the load above, six (6) of the units have the following electrical loads.

1 x 11 kW 230V range

1 x 4.8 kW electric storage hot water system

The following communal load is also installed:

1 x 400V 3 ϕ 18A Atrium air conditioning system

30 x 230V 100W security lights (10 lights per phase)

1 x 400V 35A 3 ϕ lift motor

7 MARKS

SECTION C – (Cont'd)

UNITS / P
A B C
8 8 9 UNITS = 250W
TCI COL 4

Use only the required load groups in the table below

Deduct 1 mark each incorrect line

SHOULD BE 5.0 A φ

Load Group	Load / Qty	TCI Calculation COL 4	A Red (9) UNIT	B White (8) UNIT	C Blue (8) UNIT
Ai	lighting	Column 4 9 l/u per φ (heaviest) $5A + 0.25A \times 9 = 7.25A$ heaviest φ	7.25	5+2 7	5+2 7
Aii					
Bi	10A skt outlets	Column 4 9 l/u per φ 48.8A $15A + 3.75A \times 9 = 52.5A$ heaviest φ	48.8	45	45
Bii					
Biii					
C	11kW Cooking	Column 3 2 l/u per φ 15A per φ	15	15	15
D		Inc in Bi - footnote i			
E					
F	4.8 kW O.P.H.W.	Column 3 2 l/u per φ 6A per l/u = $6A \times 2 = 12A$ per φ	12	12	12
G					
H	30 bollard	10 bollard per φ $(10 \times 100) / 230 = 4.35A$ per φ	4.35	4.35	4.35
I					
Ji					
Jii	3φ 18A AC	$75\% \times FLC = 0.75 \times 18 = 13.5A / \phi$	13.5	13.5	13.5
Jiii					
K	35A 3φ Lift	$125\% \times FLC = 1.25 \times 35 = 43.8A / \phi$	43.8	43.8	43.8
L					
M					
Maximum Demand			144.7	140.7	140.7

SECTION C – (Cont'd)

QUESTION 7. (3 Marks)

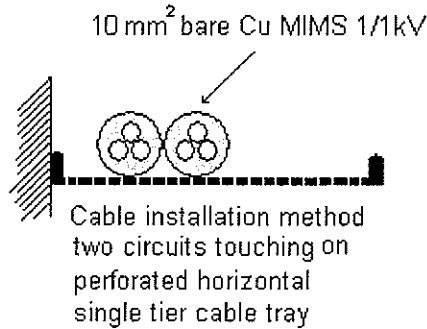

Determine the CURRENT CARRYING CAPACITY of the THREE phase 10 mm² bare multi-core Cu MIMS cable, which is installed flat on a perforated cable tray touching another similar circuit.

Bare multicore MIMS AS3008 Table 19 Item 4	Unserviced MIMS cable avoids derating AS3008.1.1 3.5.2.2 <i>p20</i>	AS3008 From Table 19 Item 4 10mm ² = 71A C.C.C. = 71A
1 Mark	1 Mark	1 Mark

QUESTION 8. (4 Marks)

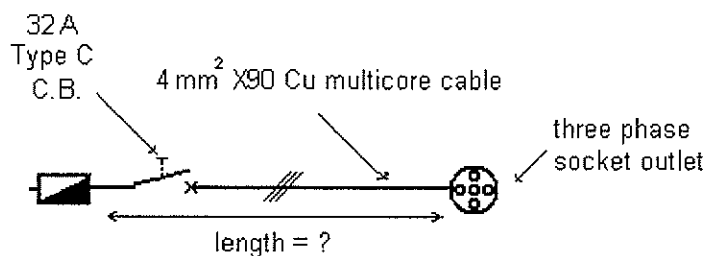

A 400V three phase final sub circuit supplying a socket outlet is to be wired with 4mm² X90 four-core and earth cable. The circuit is protected by a 32A, type C circuit breaker. The voltage drop in the cables supplying the Sub Board is 3.1% of U₀. In order to comply with AS/NZS 3000:2007 regarding volt drop, what is the maximum allowable route length of the circuit?

Total %Vd remaining 5% - 3.1% = 1.9%	1.9% x 400 = 7.6V Maximum available voltage drop remaining = 7.6V	AS3008 Table 42 4mm Cu X90 3φVc = 10.2 mV/Am	L = $\frac{1000Vd}{VcI}$ = $\frac{1000 \times 7.6}{10.2 \times 32}$ = 23.3m ✓
1 Mark	1 Mark	1 Mark	1 Mark

SECTION C – (Cont'd)

QUESTION 9. (5 Marks)

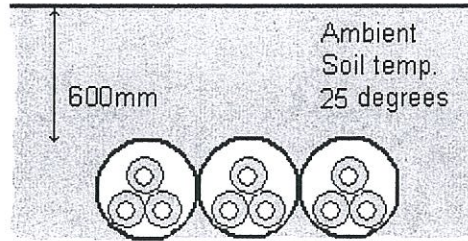

A 400V THREE phase consumer main is to be enclosed in three separate HD PVC conduits that will be installed touching underground at a depth of 600mm as shown above. The ambient soil temperature is 25 °C. The circuit will be wired with 3 x single core X90 Cu cables in parallel per phase.

A three pole 1250A circuit breaker will protect the circuit.

- a) List any applicable de-rating tables and results for the circuit

1 Mark

Multiple circuits enclosed DR table 26(2) 3 x circuits touching = 0.83 ✓
 Depth of Laying 28(2) 600mm = 0.98 ✓

1 Mark

- b) Determine the minimum required CURRENT CARRYING CAPACITY for each parallel group of cables

$$= \frac{1250}{0.83 \times 0.98}$$

$$= 1537A$$

1 Mark

$$\frac{1250}{0.98} = 1275.5A$$

- c) Determine the minimum cable size. (divide the current equally between the parallel group)

$$= \frac{1537}{3}$$

$$= 512A \text{ per cable}$$

Table 3(4) Item 2
 Table 8 Col 24
 400mm² (557A)

$$\frac{1275.5}{3} = 425A/\phi$$

T8 col 24 290mm @ 426A

1 Mark

1 Mark

SECTION C – (Cont'd)

QUESTION 10. (6 Marks)

Determine the maximum demand for the following 230/400V NON DOMESTIC RETAIL installation. Each retail shop has light, power and air conditioning loads. The office has light, power and variable volume air conditioning loads.

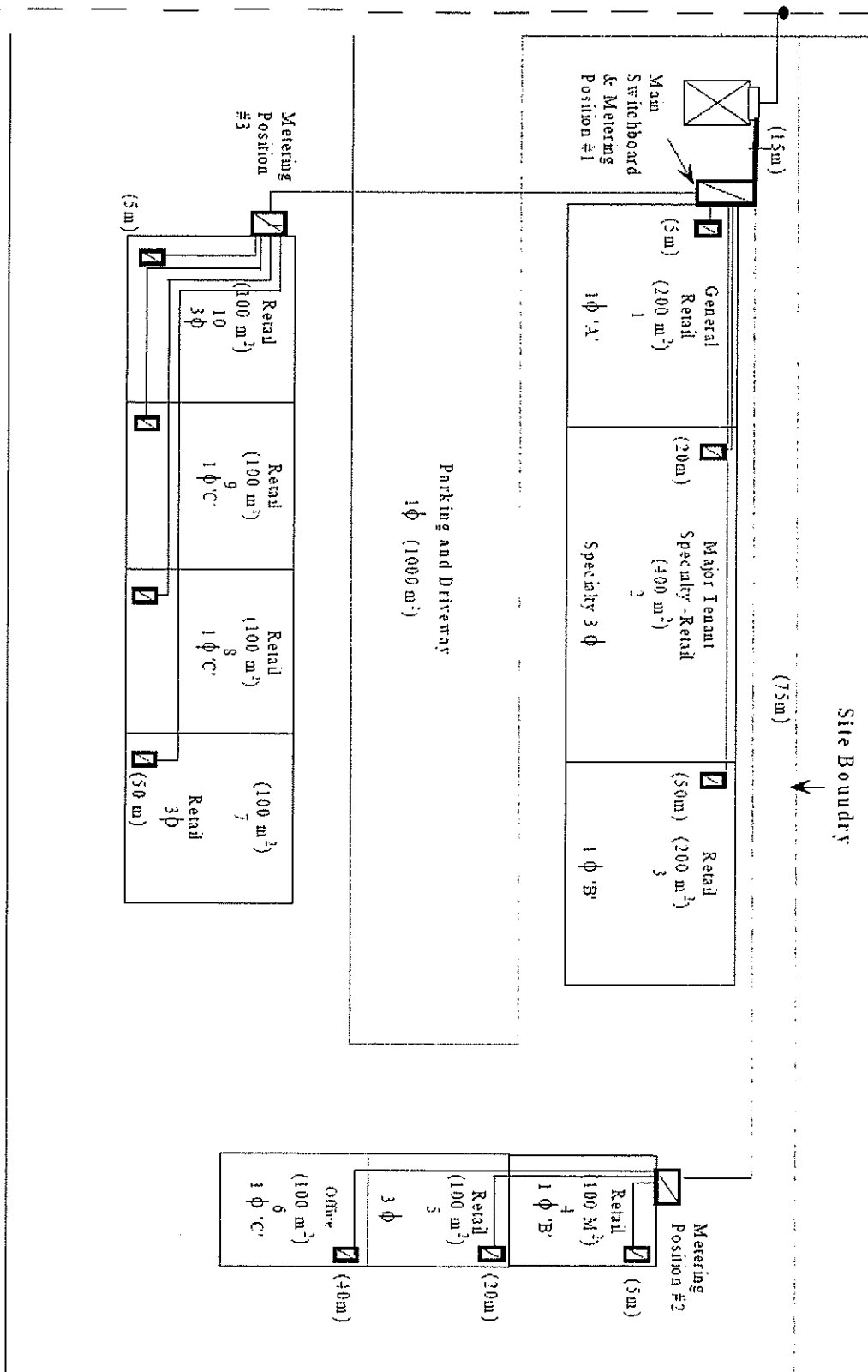

SECTION C – (Cont'd) P371

TABLE C3

Deduct 1 mark each incorrect line

Unit	Area	Calculation	A	B	C
1	200 m ²	100 VA/m ² = 20kVA 20000/230 = 87A (A)	87 ✓		
2	400 m ²	4 100 VA/m ² = 40kVA 40000/(1.732x400) = 57.7A (A B C)	57.7 ✓	57.7 ✓	57.7 ✓
3	200 m ²	100 VA/m ² = 20kVA 20000/230 = 87A (B)		87	
4	100 m ²	100 VA/m ² = 10kVA 20000/230 = 43.5A (B)		43.5	
5	100 m ²	100 VA/m ² = 10kVA 10000/(1.732x400) = 14.4A (A B C)	14.4	14.4	14.4
6	100 m ²	70 VA/m ² = 7kVA 7000/230 = 87A (C) 30.4A (C)			30.4 ✓
7	100 m ²	100 VA/m ² = 10kVA 10000/(1.732x400) = 14.4A (A B C)	14.4	14.4	14.4
8	100 m ²	100 VA/m ² = 10kVA 2 0000/230 = 43.5A (C)			43.5
9	100 m ²	100 VA/m ² = 10kVA 20000/230 = 43.5A (C)			43.5
10	100 m ²	100 VA/m ² = 10kVA 10000/(1.732x400) = 14.4A (A B C)	14.4	14.4	14.4
Carpark	1000 m ²	5 VA/m ² = 5kVA 5000/230 = 87A	21.7		
Maximum Demand			210	231	218

(End of Section C)

SECTION D – (20 Marks)

INSTRUCTION: The questions in this section require some simple drawing. Ensure that the drawing is neat and legible. The use of pencil on the drawing is acceptable in this section only.

QUESTION 1. (5 Marks)

The following diagram shows a sub board in a domestic installation. The sub mains include an active, neutral and earth from the MSB. There are four (4) final sub circuits supplying socket outlets, wired with 2.5 mm², multi-core, V90, Cu cables. The installation condition of all final sub circuits is fully surrounded by thermal insulation.

Complete all necessary active, neutral and earth connections for these four final sub-circuits on the wiring diagram below, ensuring the completed wiring complies with the relevant Australian Standards.

DEDUCT 1 MARK each incorrect connection. Deduct 5 MARKS for inclusion of a MEN connection

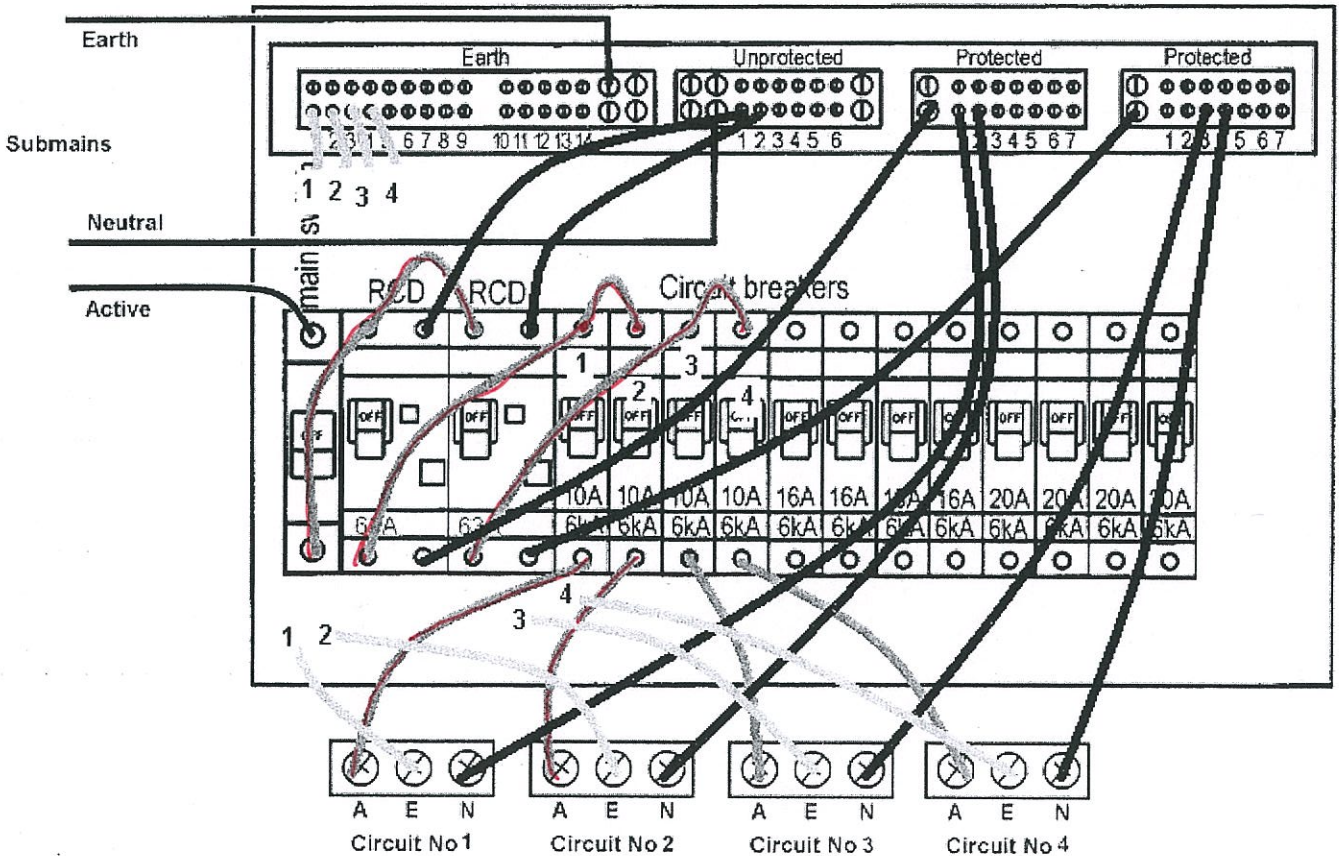

NOTE: AS3000 table C5 allows 16A for 2.5 mm sq cable completely surrounded by thermal insulation. AS3008 is not as generous, therefore either 10A or 16A breakers may be used.

SECTION D – (cont)

QUESTION 2. (5 Marks)

A 16A circuit breaker with the tripping characteristic shown below is protecting a 230V circuit wired with 2.5 mm^2 , multi-core, V90, Cu cable. The circuit is supplying socket outlets. The fault loop impedance was measured at the furthestmost point on the circuit using a fault loop impedance instrument. The result was 1.7Ω at ambient conditions (ie 40° C). Answer the following questions showing all working, and support your answer/s by marking the characteristic curve Figure 2 below.

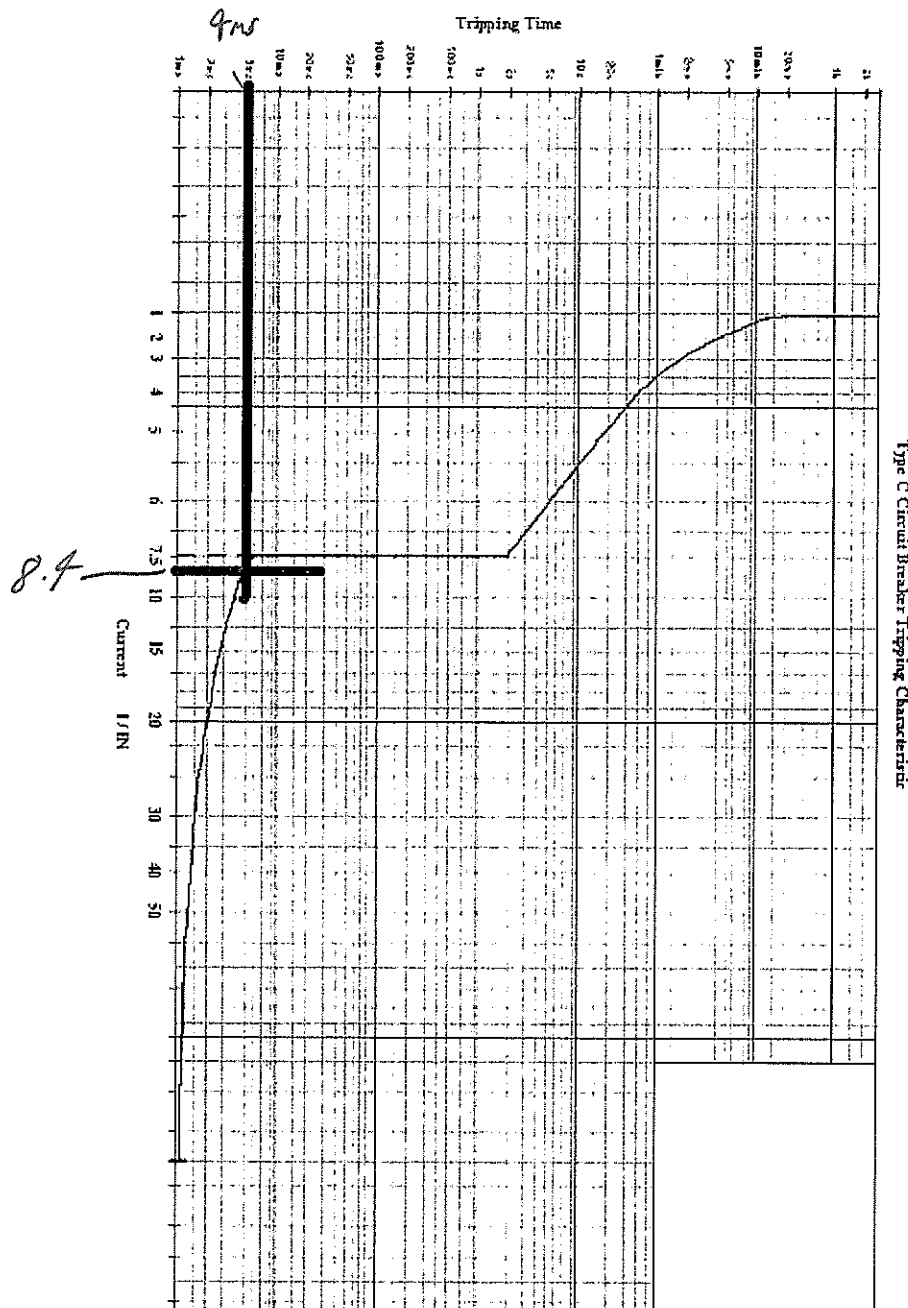

Figure 2

SECTION D – (cont)

a) Calculate the fault current for an active to earth fault at the furthestmost point.

$I_a = \frac{U_o}{Z_{fl}}$ $= \frac{230}{1.7}$ $= 135A$	
---	--

1 Mark

b) Determine the circuit breaker disconnection time considering the fault condition indicated above.

$\frac{I}{I_n}$ $= \frac{135}{16}$ $= 8.4$	1 Mark	$\approx 4ms$	1 Mark
--	---------------	---------------	---------------

c) Does the circuit meet AS/NZS 3000:2007 requirements for fault loop impedance?

YES/NO YES

Why? **1 Mark**

d) Determine the maximum allowable resistance of the protective earth conductor.

1 Mark
Re
0.61Ω

SECTION D – (cont)

QUESTION 3. (4 Marks)

DEDUCT 1 MARK each incorrect answer

The following diagram shows how the switchboard has been prepared, ready for testing the insulation resistance between active and earth of a single-phase power circuit. The circuit is protected by a 32A separate RCD and a 16A MCB. Identify the correct setting for the insulation resistance tester by placing an “X” in the appropriate box and answer the four following questions. The board is electrically isolated.

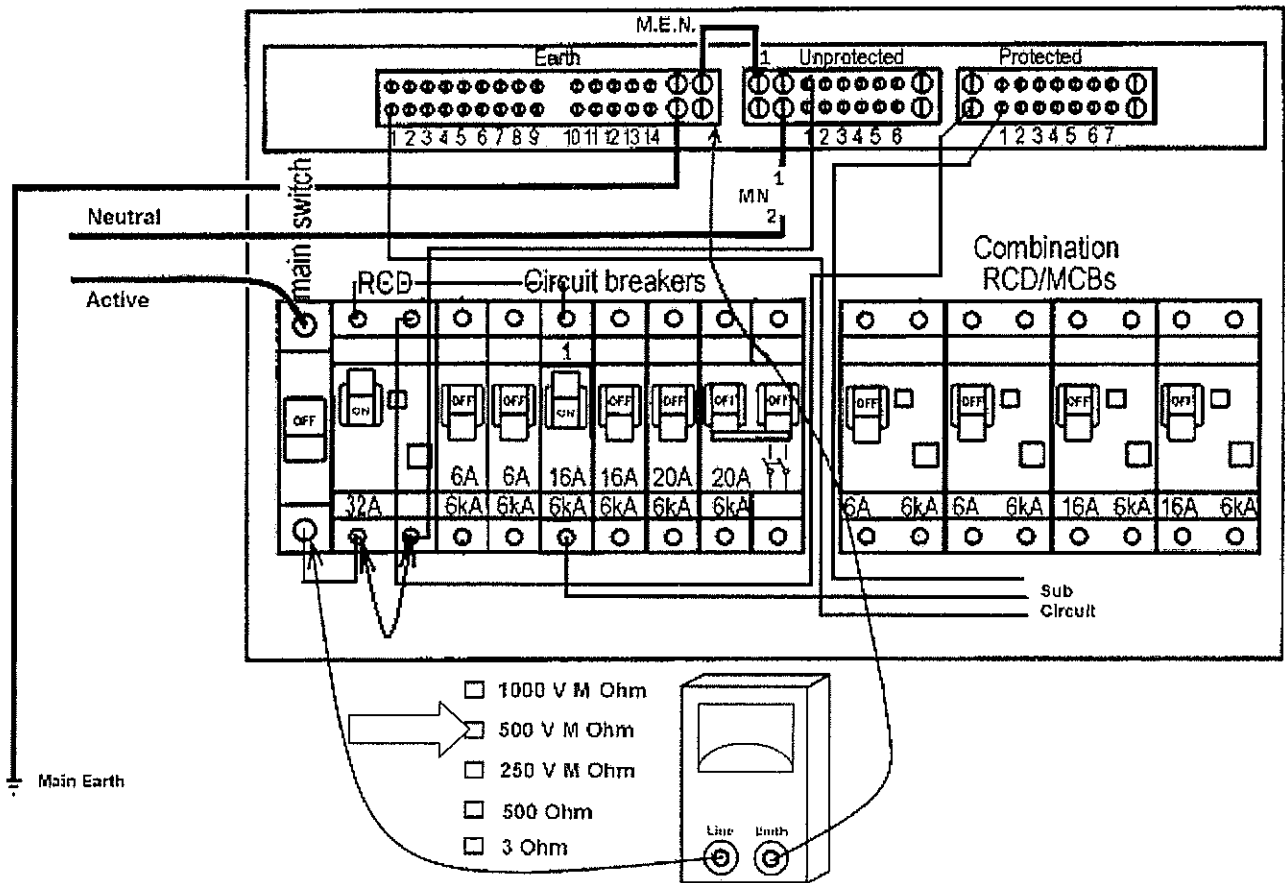

Circle the correct answer

The MEN link (2) should be:

- a) Connected to position 1 as shown
- b) **Disconnected**

A reading of ∞ M Ω would indicate:

- a) **Satisfactory result**
- b) Unsatisfactory result

The main neutral should be:

- a) **Disconnected as shown**
- b) Connected to Position 1

The leads of the testing device are:

- a) **Correctly connected**
- b) Incorrectly connected

SECTION D – (cont)

QUESTION 4. (3 Marks)

DEDUCT 1 MARK each incorrect answer

Answer the question and complete the following table using the diagram below. A correct circuit connection test is being performed. Identify the correct setting for the test equipment by placing an “X” in the appropriate box. The board is electrically isolated.

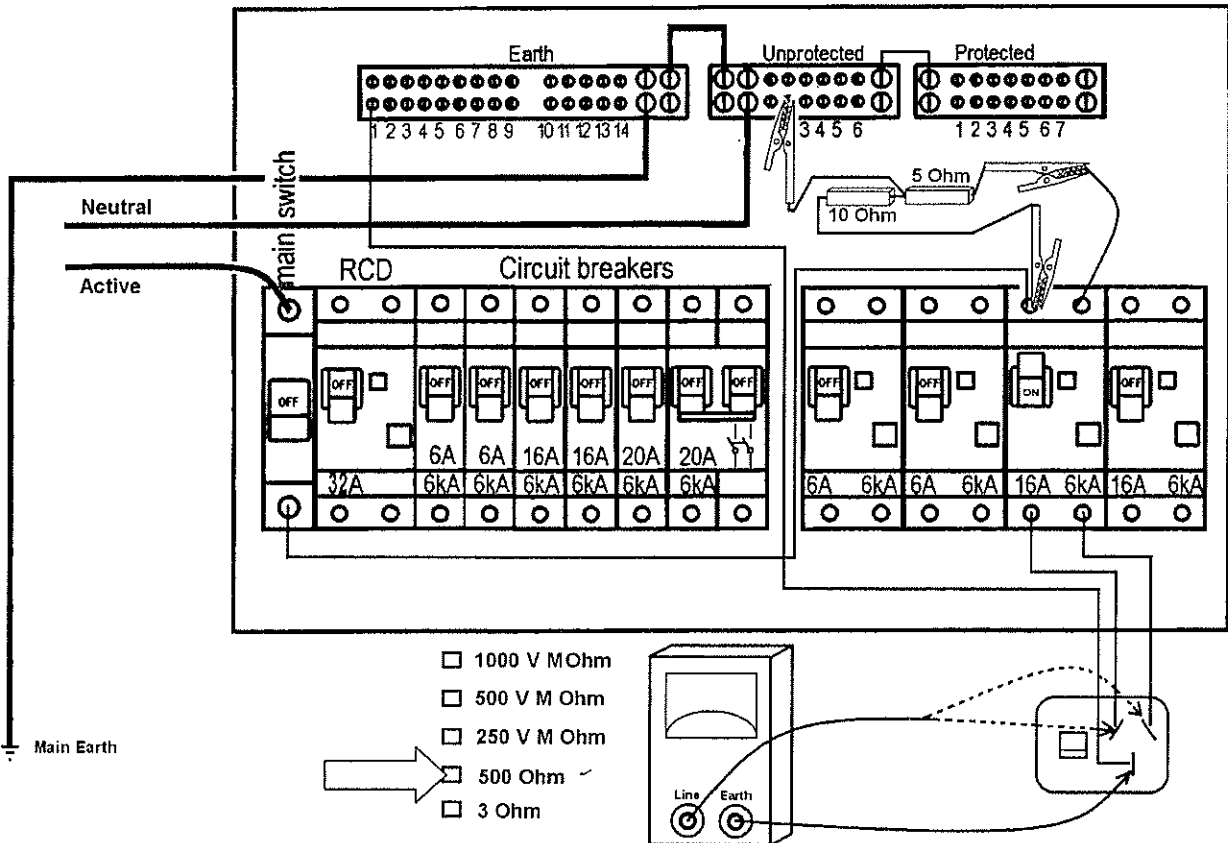

Assuming the socket outlet is correctly connected, complete the table

Test Equipment Connection	Reading
Active to Earth with socket outlet switched on	10 Ω ✓
Active to Earth with socket outlet switch off	∞ Ω ✓
Neutral to Earth with socket outlet switch off	5 Ω ✓
Neutral to Earth with socket outlet switch on	5 Ω ✓

Identify any fault indicated by a reading of approximately 15 Ω between the neutral and earth socket measured at the socket outlet:

Active Earth transposition

SECTION D – (cont)

QUESTION 5. (3 Marks)

Provide a brief written explanation highlighting why each fault is potentially dangerous.

Fault	Answer	
Insulation resistance too low	A low insulation resistance between all live conductors and earth or, as the case may be, all live parts and earth means the insulation is not adequate to ensure the integrity of the insulation. This could permit electric shock hazards from inadvertent contact; fire hazards from short-circuits and equipment damage	1 Mark
Socket outlet reversed active neutral polarity	A polarity fault due to the incorrect connection of active, neutral and earthing conductors may result in parts of appliances, such as heating elements and lampholders, remaining energised when the switches are in the 'OFF' position.	1 Mar
Intermix of two lighting circuit neutrals	A correct circuit connections fault of interconnected conductors between different circuits under some circumstances may cause disconnected neutral connections to become live.	1 Mark

(End of Section D)

Equation Data Sheet

$$\cos \phi = \frac{P}{S}$$

$$\cos \phi = \frac{R}{Z}$$

$$S = \sqrt{P^2 + Q^2}$$

$$S = VI$$

$$P = VI \cos \phi$$

$$Q = VI \sin \phi$$

$$f_o = \frac{1}{2\pi\sqrt{LC}}$$

$$V_L = \sqrt{3}V_p$$

$$I_L = \sqrt{3}I_p$$

$$S = \sqrt{3}V_L I_L$$

$$P = \sqrt{3}V_L I_L \cos \phi$$

$$Q = \sqrt{3}V_L I_L \sin \phi$$

$$\tan \phi = \sqrt{3} \left(\frac{W_2 - W_1}{W_2 + W_1} \right)$$

$$Q = mC\Delta t$$

$$V' = 4.44\Phi f N$$

$$\frac{V_1}{V_2} = \frac{N_1}{N_2}$$

$$\frac{I_2}{I_1} = \frac{N_1}{N_2}$$

$$N_{syn} = \frac{120f}{p}$$

$$s\% = \frac{(n_{syn} - n)}{n_{syn}} \times \frac{100}{1}$$

$$f_r = \frac{s\% \times f}{100}$$

$$V_{reg} \% = \frac{(V_{NL} - V_{FL})}{V_{FL}} \times \frac{100}{1}$$

$$V_{reg} \% = \frac{(V_{NL} - V_{FL})}{V_{NL}} \times \frac{100}{1}$$

$$T = \frac{\Phi Z I P}{2\pi a}$$

$$I_{ST} = \frac{1}{3} \times I_{DOL}$$

$$T_{ST} = \frac{1}{3} \times T_{DOL}$$

$$I_{ST} = \frac{V_{ST}}{V} \times I_{DOL}$$

$$T_{ST} = \left(\frac{V_{ST}}{V} \right)^2 \times T_{DOL}$$

$$I_{motor\ st} = \frac{\%TAP}{100} \times I_{DOL}$$

$$I_{line\ st} = \left(\frac{\%TAP}{100} \right)^2 \times I_{DOL}$$

$$E = \frac{\Phi_v}{A}$$

$$E = \frac{I}{d^2}$$

$$\eta_v = \frac{\Phi_v}{P}$$

$$V_L = 0.45V_{ac}$$

$$V_L = 0.9V_{ac}$$

$$V_L = 1.17V_{phase}$$

$$V_L = 1.35V_{line}$$

$$PRV = \sqrt{2}V_{ac}$$

$$PRV = 2\sqrt{2}V_{ac}$$

$$PRV = 2.45V_{ac}$$

$$V_{ripple} = \sqrt{2}V_{ac}$$

$$V_{ripple} = 0.707V_{phase}$$

$$V_{ripple} = 0.1895V_{line}$$

Equation Data Sheet

$Q = It$	$v = \frac{s}{t}$	$a = \frac{\Delta v}{t}$
$F = ma$	$W = Fs$	$W = mgh$
$W = Pt$	$\eta\% = \frac{\text{output}}{\text{input}} \times \frac{100}{1}$	$I = \frac{V}{R}$
$P = VI$	$P = I^2 R$	$P = \frac{V^2}{R}$
$R_2 = \frac{R_1 A_1 l_2}{A_2 l_1}$	$R_t = R_c (1 + \alpha \Delta t)$	$R = \frac{\rho l}{A}$
$R_T = R_1 + R_2 + R_3$	$V_T = V_1 + V_2 + V_3$	$\frac{1}{R_T} = \frac{1}{R_1} + \frac{1}{R_2} + \frac{1}{R_3}$
$I_T = I_1 + I_2 + I_3$	$V_2 = V_T \frac{R_2}{R_1 + R_2}$	$I_2 = I_T \frac{R_1}{R_1 + R_2}$
$R_x = \frac{R_A R_B}{R_B}$	$C = \frac{Q}{V}$	$\tau = RC$
$\frac{1}{C_T} = \frac{1}{C_1} + \frac{1}{C_2} + \frac{1}{C_3}$	$C_T = C_1 + C_2 + C_3$	$C = \frac{A \epsilon_0 \epsilon_r}{d}$
$F_m = IN$	$H = \frac{F_m}{l}$	$B = \frac{\Phi}{A}$
$\Phi = \frac{F_m}{S}$	$S = \frac{l}{\mu_o \mu_r A}$	$V = N \frac{\Delta \Phi}{\Delta t}$
$e = Blv$	$L = \frac{\mu_o \mu_r AN^2}{l}$	$L = N \frac{\Delta \Phi}{\Delta I}$
$V = L \frac{\Delta I}{\Delta t}$	$\tau = \frac{L}{R}$	$F = Bil$
$T = Fr$	$E_z = \frac{\Phi ZnP}{60a}$	$P = \frac{2\pi nT}{60}$
$t = \frac{1}{f}$	$f = \frac{np}{120}$	$V = 0.707V_{\max}$
$I = 0.707I_{\max}$	$V_{\text{ave}} = 0.637V_{\max}$	$I_{\text{ave}} = 0.637I_{\max}$
$v = V_{\max} \sin \phi$	$i = I_{\max} \sin \phi$	$I = \frac{V}{Z}$
$Z = \sqrt{R^2 + (X_L - X_C)^2}$	$X_L = 2\pi fL$	$X_C = \frac{1}{2\pi fC}$

Name:.....

College:.....

ANSWER SHEET – Section A (Multi-choice Questions)

Module - 6077AC

Examination Date: 23rd June 2010

Instructions:

- Enter your name and college on this sheet.
- Place an **X** in box of your choice. If you make a mistake- circle your answer **(X)** and choose again.
- For your convenience you can remove this page while you answer Section A. **Remember to re-attach it** to the paper when you hand it in.

Question	a	b	c	d
1			X	
2		X		
3				X
4	X			
5		X		
6	X			
7				X
8		X		
9				X
10				X
11	X			
12	X			
13			X	
14			X or X	
15		X		
Totals	4	4	3	4
Total Correct Section A				

1.5.5.3d P95

Total Marks Section A: /15

END OF EXAMINATION