



Family Name .....

Given Name .....

Student Number .....

Centre .....

Signature .....

*2 December 2010*

**6077AC Electrical Systems Safety – Capstone Assessment**

*Time allowed – Three hours plus Ten minutes reading time*

*27 Pages in this Question Booklet*

*All Questions to be attempted*

**TOTAL MARKS AVAILABLE =100**

**Aids to be supplied by college:**

- None.

**Aids to be supplied by student:**

- Australian/New Zealand Wiring rules AS/NZS 3000:2007, AS3008.1.1, AS3017, NSW Installation and Service Rules
- Students own marginal notes, indexing and formal amendments may be included in the above regulation books.
- Pen, pencil, eraser, rule, calculator.

Section	Possible Marks	Achieved Marks
A	15	
B	20	
C	40	
D	25	
<b>Total</b>	<b>100</b>	

**Instructions to student:**

- **Mobile phones are to be turned off and removed from your person.** You cannot access a mobile phone during this examination.
- All questions to be answered in the space provided on this **examination paper**. Answers to Section A – multi-choice questions, are to be answered on the sheet attached to this examination paper.
- You are not to use any other reference books in this examination.
- The whole of this paper is to be handed to the Supervisor upon completion.

**Aids permitted where indicated:**

Standard Dictionaries	Bilingual Dictionaries	Technical Dictionaries	Programmable Calculators	Non-programmable Calculators	Electronic Devices
Yes	No	No	No	Yes	No

## SECTION A – (15 Marks)

**Instructions:** Select the best answer for the following statements and place an 'X' in the appropriate box on the Answer Sheet attached to this examination paper. Each correct answer is worth one (1) mark.

### QUESTION 1. (1 Mark)

What is the most common method of fault protection?

- (a) automatic disconnection of the supply
- (b) use of class II equipment or equivalent insulation
- (c) electrical separation of the system, in accordance with clause 1.5.5.5
- (d) limit the fault current that can pass through a body to a value lower than the shock current

### QUESTION 2. (1 Mark)

What are the touch voltage limits?

- (a) 12Vac or 32Vdc
- (b) 32Vac or 50Vdc
- (c) 50Vac or 120Vdc
- (d) 50Vac or 500Vdc

### QUESTION 3. (1 Mark)

What type of insulation must be used to replace removed or damaged insulation when joining cables?

- (a) reinforced insulation
- (b) PVC tape
- (c) insulation which is not inferior to that which was removed
- (d) encapsulated in resin

### QUESTION 4. (1 Mark)

Where double insulation is maintained between the point of supply and the load terminals of the protective devices for the sub-mains and final sub-circuits, the size of the main earth may be determined by:

- (a) the largest active conductor of the largest outgoing sub-main or final sub-circuit
- (b) the consumers mains
- (c) the maximum permissible fault current
- (d)  $4\text{mm}^2$

## SECTION A – (Cont'd)

### QUESTION 5. (1 Mark)

Polarity testing is performed on a socket outlet:

- (a) to ensure conductors are not transposed
- (b) only on the earth conductor
- (c) only on the active conductor
- (d) to ensure there is no intermix from other circuits

### QUESTION 6. (1 Mark)

A major hazard with confined spaces is:

- (a) difficulty in using tools
- (b) cramped working conditions
- (c) only one person can work at a time
- (d) flammable contaminants

### QUESTION 7. (1 Mark)

When selecting a circuit breaker for a final sub-circuit, its rating should be:

- (a) equal to or less than the demand of the final sub-circuit and equal to or more than the cables continuous current carrying capacity
- (b) equal to or less than the demand of the final sub-circuit and equal to or less than the cables continuous current carrying capacity
- (c) equal to or more than the demand of the final sub-circuit and equal to or more than the cables continuous current carrying capacity
- (d) equal to or more than the demand of the final sub-circuit and equal to or less than the cables continuous current carrying capacity

$$I_B \leq I_N \leq I_2$$

## SECTION A – (Cont'd)

### QUESTION 8. (1 Mark)

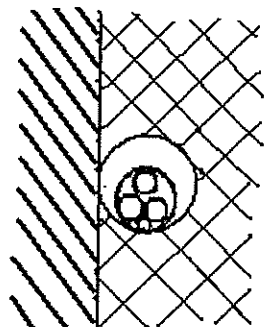

Figure 1

What does the picture illustrated in figure 1 represent?

- (a) enclosed three core cable, partially surrounded by thermal insulation
- (b) three single core cables enclosed, completely surrounded by thermal insulation
- (c) enclosed three core cable, completely surrounded by thermal insulation
- (d) three single core cables enclosed, partially surrounded by thermal insulation

### QUESTION 9. (1 Mark)

The values for calculating cable voltage drop as given in Table 40 to 50 in AS3008.1.1 are three phase. What is the *factor* applied to these values to convert them to *single phase*?

- (a) multiply the table value by 1.732
- (b) divide the table value by 1.732
- (c) multiply the table value by 1.155
- (d) divide the table value by 1.155

### QUESTION 10. (1 Mark)

What is the maximum allowable disconnection time for a range supplied with 230 V, 50 Hz in the event of a short circuit between active and earth?

- (a) 0.4 seconds
- (b) 1 second
- (c) 5 seconds
- (d) 1 minute

## SECTION A – (Cont'd)

### QUESTION 11. (1 Mark)

Which of the following would not be dealt with by the application of a de-rating factor, when selecting cables based on current carrying capacity?

- (a) circuit protection by a fuse
- (b) enclosed by thermal insulation
- (c) high ambient temperature
- (d) installed on unperforated cable tray

### QUESTION 12. (1 Mark)

Who of the following would not receive a copy of the 'Certificate of Compliance' - Electrical Work for a new installation that is to be connected to the supply in the street?

- (a) the customer
- (b) the contractor
- (c) the Office of Fair Trading
- (d) the supply authority

### QUESTION 13. (1 Mark)

AS/NZS3000 states that every electrical installation shall be divided into a number of circuits. A reason for this is to:

- (a) make efficient use of cables and energy converters
- (b) facilitate safe operation, inspection, maintenance and testing
- (c) make efficient use of protective devices
- (d) reduce the length and loading of circuits

### QUESTION 14. (1 Mark)

Safety at work is the responsibility of:

- (a) building owners and employers
- (b) work site supervisor
- (c) employers and their employees
- (d) owner and/or controller of the work site and employers and their employees

**SECTION A – (Cont'd)**

**QUESTION 15. (1 Mark)**

What is the maximum allowable resistance of a main earthing conductor?

- (a) not specified
- (b) 0.5 ohms
- (c) 2 ohms
- (d) a value low enough to cause circuit protection to operate in the event of a fault

**(END OF SECTION A)**

## SECTION B – (20 Marks)

**Instructions:** Blank spaces in the following statements represent omissions. Write the appropriate word, words or information in the numbered spaces provided.

- Use AS/NZS 3000:2007 to best answer each question.
- Write clause or table numbers where required.

### QUESTION 1. (2 Marks)

Two methods for preventing live parts or parts separated from live parts by single insulation, from coming into contact with structural metalwork if a conductor was to break at a termination are:

.....  
.....  
.....

(Clause number .....)

### QUESTION 2. (2 Marks)

What precautions are required when installing down-lights in a ceiling near loose fill thermal insulation materials?

.....  
.....  
.....

(Clause number .....)

### QUESTION 3. (2 Marks)

When selecting and installing an earthing arrangement, what function must the arrangement perform when carrying earth fault and earth leakage currents?

.....  
.....  
.....  
.....

(Clause number .....)

**SECTION B – (Cont'd)**

**QUESTION 4. (2 Marks)**

What value of current should be used when calculating voltage drop on a circuit?

.....  
.....  
.....

(Clause number .....)

**QUESTION 5. (2 Marks)**

What types of thermoplastic cables are suitable for an installation operating at minus eight degrees?

.....  
.....  
.....

(Clause number .....)

**QUESTION 6. (2 Marks)**

What are the requirements for installing a twenty metre run of rigid PVC conduit, not marked with the letter 'T', in direct sunlight where the temperature may vary between zero and forty degrees Celsius?

.....  
.....  
.....

(Clause number.....)

**QUESTION 7. (2 Marks)**

When the MEN connection is not made at one extremity of the neutral bar or link and the main neutral is not connected in the next adjacent terminal, what would be the requirements for identifying the main neutral and MEN connection at the bar or link?

.....  
.....  
.....

(Clause number.....)



**SECTION B – (Cont'd)**

**QUESTION 8. (2 Marks)**

What is the maximum length of unprotected interconnecting conductors from a solar electricity generation system?

.....  
.....

(Clause number .....)

**QUESTION 9. (2 Marks)**

Isolation switches operating in an AC motor supply circuit shall be capable of interrupting the locked rotor current. In the absence of any specific information supplied by the manufacturer, the locked rotor current shall be taken as?

.....  
.....  
.....

(Clause number.....)

**QUESTION 10. (2 Marks)**

What is the recommended maximum number of 2.5mm<sup>2</sup> two core and earth circular cables that may be installed in 40mm medium duty corrugated conduit?

.....  
.....

(Clause number .....)

**(END OF SECTION B)**

### SECTION C – (40 Marks)

**Instructions:** This section involves calculations. Show all necessary working in the space provided. Marks will be awarded accordingly. **Answers are to be highlighted or underlined.**

#### QUESTION 1. (4 Marks)

A three-phase distribution switchboard located in a commercial installation, comprising mainly single phase loads, has a maximum demand of 141A per phase. Given that the sub-main into the distribution switchboard is a four-core R-EP-90 copper cable, which is installed touching a surface, determine:

- (a) The required current rating of the neutral conductor with AS/NZS3000 reference

AS/NZS3000 reference.....

- (b) The size of the neutral conductor with the AS/NZS3008.1.1 reference

AS/NZS3008.1.1 reference.....

## SECTION C – (Cont'd)

### QUESTION 2. (6 Marks)

A single phase domestic installation has the following load. Calculate the maximum demand for the installation

Room	Load
Kitchen	1 fitting with 6 x 9W lamps, 3 fittings with 1 x 9W ceiling fluorescent down lights, 1 x 15W pendant fluorescent lamp, 2 double SO, 1 single SO, 100W range hood, 4.6kW oven, 5.6kW hotplate
Dining	1 x 15W pendant fluorescent lamp, 3 fittings with 1 x 9W ceiling fluorescent down lights, 1 double SO
Family	5 x 9W ceiling fluorescent down lights, wall unit 5 x 9W fluorescent down lights, 4 double SO, 3kW Air. Con.
Laundry	1 x 9W lamp, 1 double SO, 400L off peak HWS with a 12 ohm 4.8kW 240V rated element
Toilet 1	1 x 9W lamp
Lounge	1 fitting with 3 x 9W lamps, 4 double SO
Foyer	1 fitting 3 x 9W lamps, 1 single SO
Porch	3 fittings with 1 x 9W lamps
Deck	1 weatherproof 300W quartz halogen lamp, 1 WP double SO
Bedrooms 1 to 3 (each room)	1 fitting with 3 x 9W lamps, 2 double SO
Master bedroom	1 fitting with 5 x 9W lamps, 4 double SO
Wardrobe	1 x 9W lamp
Hall 2	1 x 9W lamp, 1 single SO
Ensuite	1 x 9W lamp, 60W ceiling exhaust fan, 750W strip heater, 1 double SO
Bathroom	1 x 9W lamp, 60W ceiling exhaust fan, 2 x 375W heat lamps, 1 x 1800W spa heater, 1 x 750W spa pump
Vanity	1 x 9W lamp, 1 double SO
Toilet 2	1 x 9W lamp

Total lighting points	
Total socket outlets	



## SECTION C – (Cont'd)

### QUESTION 3. (6 Marks)

A multiple domestic installation comprises of 20 identical two bedroom units with dedicated undercover parking and one car wash bay. The installation also has a common BBQ area suitable for family picnics. The communal load is separately metered with one only *single phase meter on C phase*. Determine the maximum demand of the three phase 230/400V installation.

Each unit has the following associated load:

- 32 lighting points
- 19 double socket outlets
- 4 single socket outlets
- 1 combination 2 lamp heater/light/exhaust fan unit 3.5A
- 1 combination 4 lamp heater/light/exhaust fan unit 6A
- Stiebel Eltron 300L heat pump HWS 3A
- Induction cook top 5.9kW
- Built in oven/grill 2.1kW max
- 3.0 hp air-conditioner 11.5A max

The communal load associated with the installation is as follows

- 1 automatic garage door motor 3.9A
- 20 garage lights each having a maximum rating of 60W
- 12 bollard lights each having a maximum rating of 60W
- 12 hall and stairwell lights having a maximum rating of 60W
- 24 socket outlets

**SECTION C – (Cont'd)**

Load	Load group	Calculation	Phase A	Phase B	Phase C
		<b>Total</b>			

**Maximum Demand = \_\_\_\_\_**

**SECTION C – (Cont'd)**

**QUESTION 4. (6 Marks)**

Calculate the maximum demand of three phase factory load listed below. All of the factory is heated by 30kW gas heater. The supply is 230/400V

- 18 - 3.3A high bay lamps
- 36 -twin fluorescent lamps at 0.46A per fitting
- 4– 300W quartz halogen lamps
- 2– 18kW, 400V 40A per phase, 3 phase motor
- 2 – 9kW, 400V 23A per phase, 3 phase motor
- 2– 4.8kW, 400V 10 A per phase, 3 phase motors
- 3-2.9kW, 230V 50L quick recovery water heaters
- 2-2000kW instantaneous water heaters
- 10-three phase 30A socket outlets
- 30 double 10A single phase socket outlets
- 22 single 10A single phase socket outlets

Load	Load group	Calculation	Phase A	Phase B	Phase C
		<b>Total</b>			

Maximum Demand = \_\_\_\_\_ A

### SECTION C – (Cont'd)

#### QUESTION 5. (4 Marks)

A final sub-circuit to supply a single phase motor with a maximum demand of 22A and a route length of 42 metres is wired with 4mm<sup>2</sup>, TPS V90 flat multi-core copper cable installed in heavy duty PVC conduit. Calculate the voltage drop in the cable.

Answer .....Volts

Reference.....

#### QUESTION 6. (4 Marks)

A three phase sub-main to supply a factory consists of X90 SDI copper conductors installed in trefoil on a horizontal perforated cable tray touching two other sub-mains. The maximum demand of the factory is 212A.

- (a) Determine the minimum acceptable size of the active conductor

Size.....

References.....

References.....

- (b) Determine an acceptable size for the sub-main earth conductor

Size.....

References.....



### SECTION C – (Cont'd)

#### QUESTION 7. (4 Marks)

A 230V final sub-circuit is to be wired in 6 mm<sup>2</sup> V90, TPI conductors with a 4mm<sup>2</sup> earth to enable the circuit length to be increased. The circuit is protected by a 40A Type C circuit breaker and has a maximum demand of 34A. Determine the increased length obtained by using a 4mm<sup>2</sup> earth conductor instead of a 2.5mm<sup>2</sup> earth conductor with regard to fault loop impedance.

Maximum length using a 2.5mm<sup>2</sup> earth cable \_\_\_\_\_ metres

Maximum length using a 4.0mm<sup>2</sup> earth cable \_\_\_\_\_ metres

Increased length \_\_\_\_\_ metres

#### QUESTION 8. (6 Marks)

The prospective short circuit current at the point of service for a 230/400V installation is 30kA.

- (a) Determine the source impedance for the installation.

Z source = \_\_\_\_\_ ohms

- (b) If the consumers mains are 120mm<sup>2</sup> SDI V90 aluminium conductors and 35 metres long, determine the prospective short circuit current at the main switchboard.

Prospective short circuit current \_\_\_\_\_ kA

- (c) If a distribution board is fed by sub-mains, originating at the main switchboard and are 120 metres long, 50mm<sup>2</sup> multi-core V75 copper conductors, determine the prospective short circuit current at the distribution board.

Prospective short circuit current \_\_\_\_\_ kA

### SECTION D – (25 Marks)

**Instruction:** The question in this section requires some simple drawing. Ensure that the drawing is neat and *legible*. The use of pencil on the drawing is acceptable in this section only.

#### QUESTION 1. (4 Marks)

A domestic installation is supplied with parallel 16mm<sup>2</sup> unprotected consumers mains where double insulation is not maintained up to the service fuse and service neutral link. Complete the following tasks on Figure 2

- (a) On the main switchboard draw all cables used for earthing and identify any specific 'marking' requirements for the cables and or positions.
- (b) Mark next to the cables the minimum required size as specified in AS/NZS3000

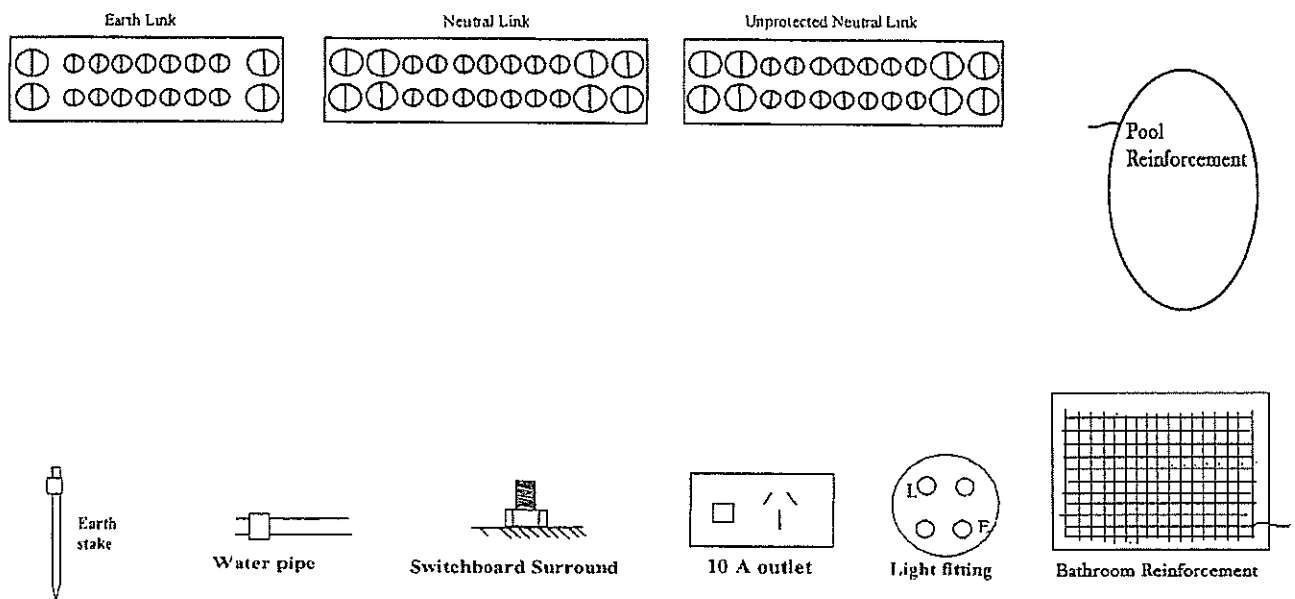

Figure 2

### SECTION D – (Cont'd)

#### QUESTION 2. (4 Marks)

The suitability of a 32A type C circuit breaker having a tripping characteristic shown in Figure 3 to protect a circuit supplying a motor that takes 6 second to run up to speed and has a maximum starting current of 240A. Show all working and how you came to your answer from the diagram.

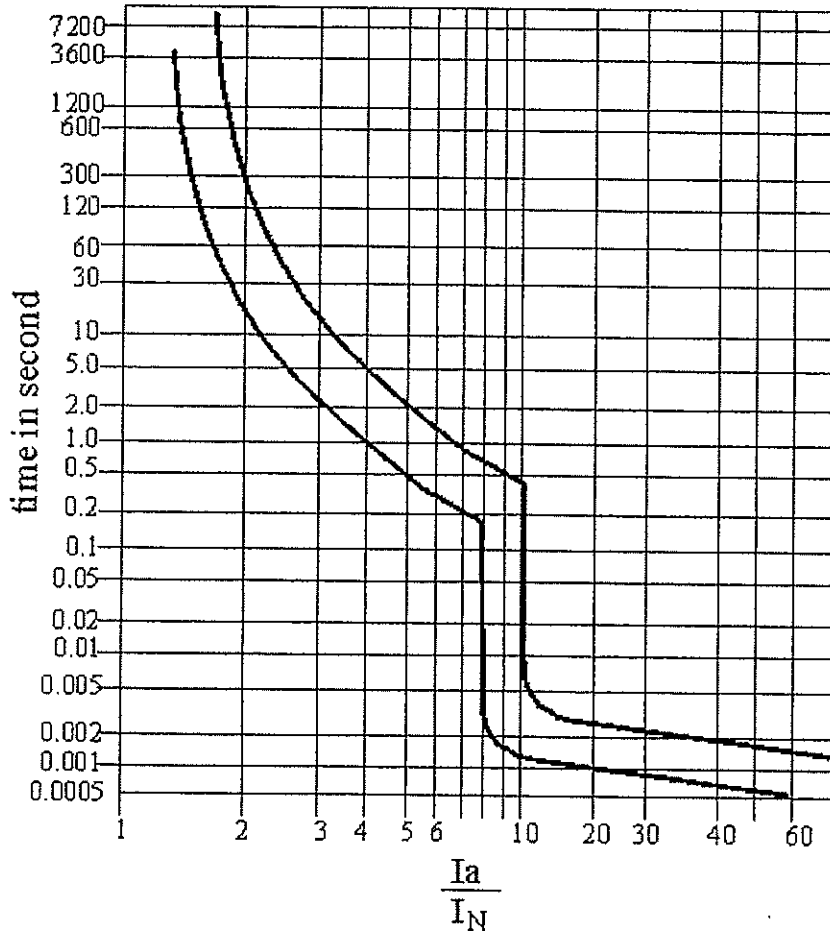

Figure 3

---

---

---

---

---

---

---

---

---

---

Suitable / Unsuitable

### SECTION D – (Cont'd)

#### QUESTION 3. (4 Marks)

A polarity test is to be performed on a final sub-circuit, containing socket outlets. Record your results for the polarity test in the table below.

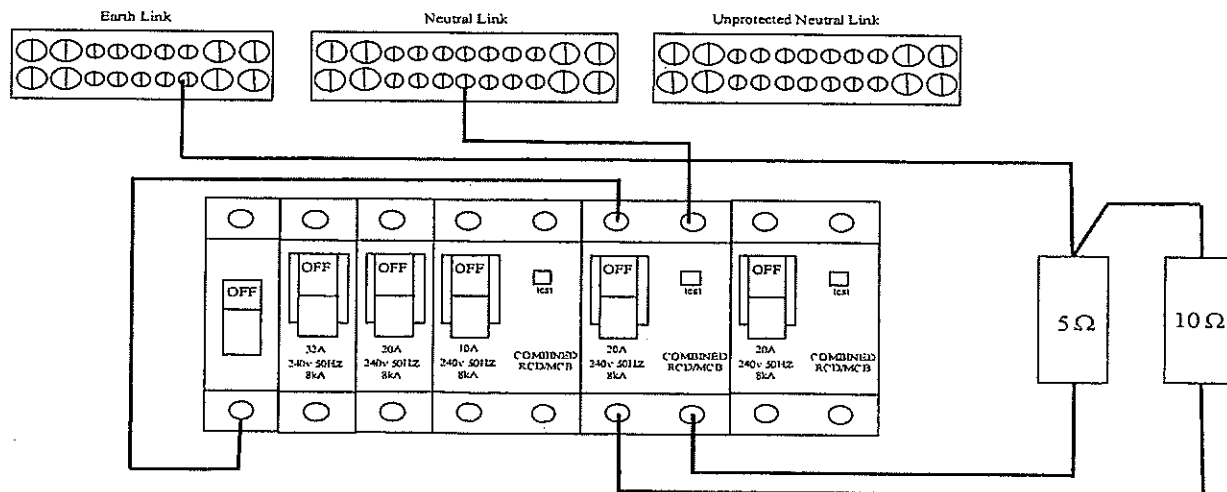

**Switchboard connections**

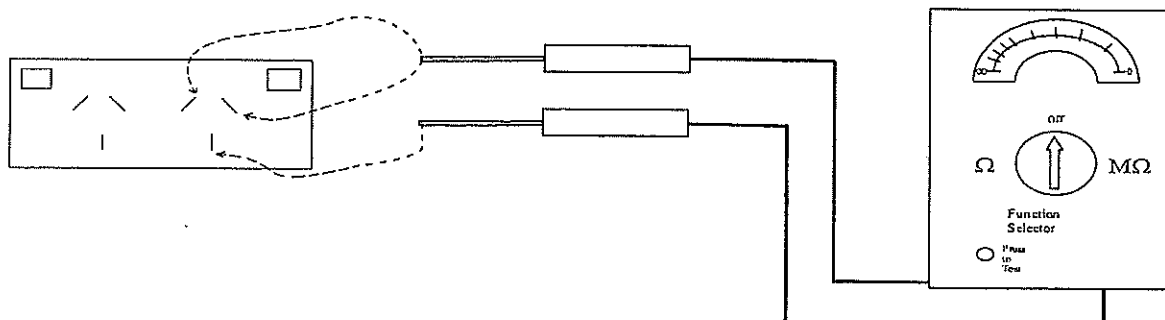

**Figure 4**

Select correct meter position, circle correct selection below,

3Ω, 500Ω, 250V, 500V, 1000V (1mark)

The results for correct polarity check would be: (3marks)

Combination	Result
Active-neutral	Ω
Active-earth	Ω
Neutral-earth	Ω
Active-neutral Switched off	Ω
Active-earth Switched off	Ω
Neutral-earth Switched off	Ω

## SECTION D – (Cont'd)

### QUESTION 4. (4 Marks)

Complete the required sections on the Certificate of Compliance – Electrical Work on the following page to satisfy the following. Note: Do NOT include any details for the electrician or tester.

<b>Customer:</b>	Malcolm Turnbull, 77 Florida Drive, Canberra. 2299.	
<b>Cross street:</b>	Coronation Drive	
<b>Meter number:</b>	11772	
<b>Electrician:</b>	Ignore any reference	
<b>Installation details</b>	Install 5 light points and 6 socket outlets to existing circuits for a small extension.	
<b>Consumer mains:</b>	Four by 16mm <sup>2</sup> SDI	
<b>Main earth electrode:</b>	1meter to the left of the switchboard	
<b>Water service equipotential bond:</b>	At water pipe entry at front of building on switchboard side of building	
<b>Test results:</b>		
Insulation resistance:	Water heater	0.8 MΩ
	Range	0.4 MΩ
	Other circuits	Infinity
Earth continuity:	Main earth	0.1 Ω
	Equipotential bond	0.1 Ω
	All other	<0.4 Ω
All other tests:	Correct	

### SECTION D – (Cont'd)

## CERTIFICATE OF COMPLIANCE – ELECTRICAL WORK

Customer COPY

CERTIFICATE NO: 000403

#### CUSTOMER DETAILS

Name			Telephone Contact	
Address			Meter No:	
Cross Street		Postcode	NMI (if applicable)	

<b>INSTALLATION WORK DETAILS</b> Indicate the type of installation and types of work performed under this Notice					
Type of Installation	<input type="checkbox"/> Residential	<input type="checkbox"/> Commercial	<input type="checkbox"/> Industrial	<input type="checkbox"/> Rural	<input type="checkbox"/> Other
Special Conditions	<input type="checkbox"/> over 100 amps	<input type="checkbox"/> High Voltage	<input type="checkbox"/> Hazardous Area	<input type="checkbox"/> Generator	<input type="checkbox"/> Unmetered Supply

**CERTIFICATE MUST BE ISSUED TO THE CUSTOMER FOR ALL ELECTRICAL WORK**

Work of the following type must ALSO be notified to the **ELECTRICITY DISTRIBUTOR (DNSP)**

<input type="checkbox"/> New Installation	<input type="checkbox"/> Network connection or metering
<input type="checkbox"/> Additions or alterations to a switchboard or associated equipment	<input type="checkbox"/> Defect Rectification No:

**DETAILS OF EQUIPMENT** Describe the equipment and estimate load increase of the work affected by this Notice. If insufficient space attach separate sheets.

EQUIPMENT	RATING	No.	PARTICULARS OF WORK
<input type="checkbox"/> Switchboards			
<input type="checkbox"/> Circuits			
<input type="checkbox"/> Lighting			
<input type="checkbox"/> Socket-outlets			
<input type="checkbox"/> Appliances			
Estimated increase in load A/ph			<input type="checkbox"/> Increased load is within capacity of installation/service mains
<input type="checkbox"/> Work is connected to supply			<input type="checkbox"/> Work is not connected to supply pending inspection by DNSP

The work has been carried out or supervised by:  Licence No:

**TEST REPORT** Indicate the relevant tests and checks that have been performed on the work. If test records are provided attach as separate sheets.

<input type="checkbox"/> Earthing system integrity Ω	<input type="checkbox"/> Residual current device operation
<input type="checkbox"/> Insulation resistance MΩ	<input type="checkbox"/> Visual check that installation is suitable for connection to supply
<input type="checkbox"/> Polarity	<input type="checkbox"/> Stand-alone power system complies with AS 4509
<input type="checkbox"/> Correct circuit connections	<input type="checkbox"/> Fault loop impedance (if necessary)

I confirm that I have carried out the above tests and visually checked that the installation work described in this Certificate complies with AS/NZS 3000 and is suitable for its intended use.

Name:  Licence No:

Signature:  Date of Testing:

**CERTIFICATION**  
I, the Electrical Contractor give notice to the Customer and (Name of DNSP or OFT), that the work described in this Certificate has been completed in accordance with the Electricity (Consumer Safety) Regulation 2006

Name:  Licence No:

Signature:  Date of Notice:

Address:  Telephone No. or Other Contact:

**ELECTRICITY DISTRIBUTOR (DNSP) REMARKS**

Inspected by:  Date:

Comments:



### SECTION D – (Cont'd)

#### QUESTION 5. (4 Marks)

The equipment shown below is for a distribution board for a single dwelling. The four final sub-circuits are to be connected using the breakers shown below. All the final sub-circuits are wired with V90 cable and partially surrounded by thermal insulation. Show on the diagram the necessary Active and Neutral connections to supply these circuits.

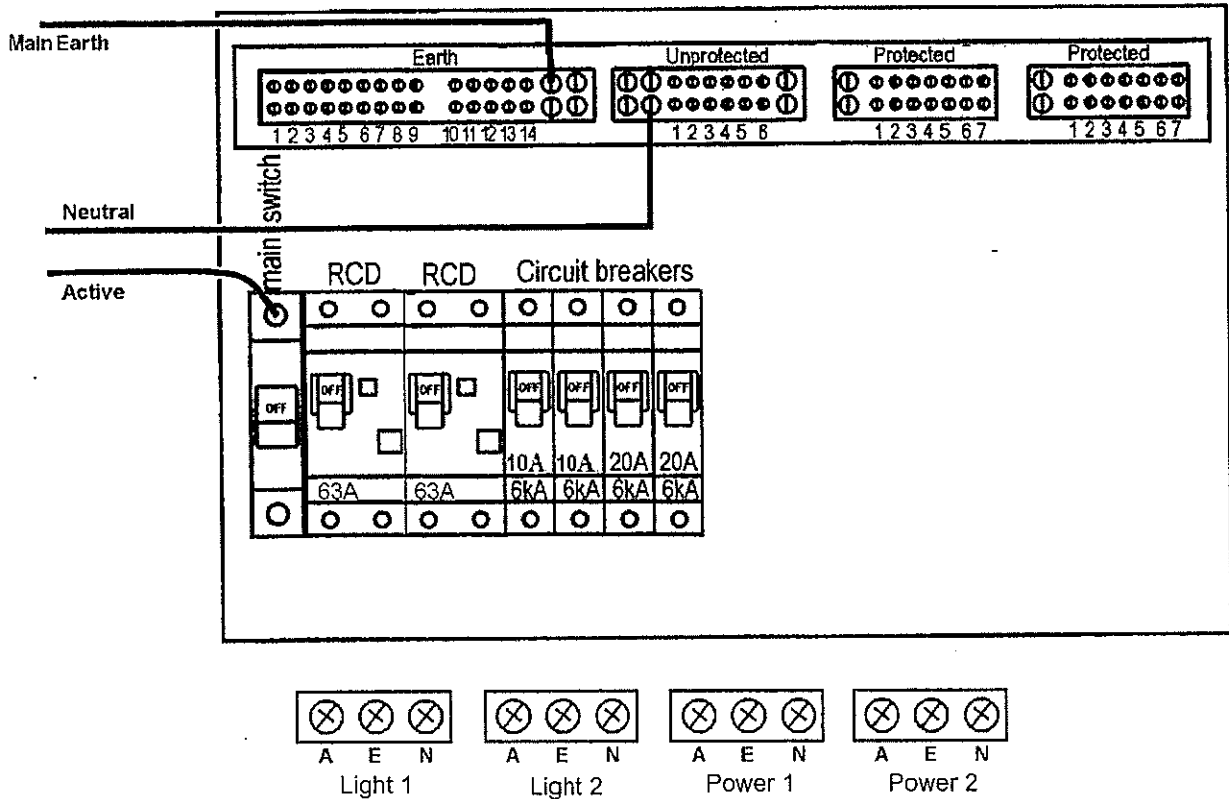

Figure 5

**SECTION D – (Cont'd)**

**QUESTION 6. (5 Marks)**

List the procedure for performing an insulation resistance test on the whole installation for Question 5 on page 23.

---

---

---

---

---

---

---

---

---

---

---

---

---

---

---

---

---

---

---

---

---

---

---



# MARKING GUIDE

**Module/Unit No:** 6077AC

**Module/Unit Name:** Electrical Systems Safety  
- Capstone Assessment  
(Theory)

**Exam Date:** 2/12 /10

**Number of Pages:** 29 (including this page)

Name:.....

College:.....

### ANSWER SHEET – Section A (Multi-choice Questions)

Module - 6077AC

Examination Date: September 2010

**Instructions:**

- Enter your name and college on this sheet.
- Place an **X** in box of your choice. If you make a mistake- circle your answer **(X)** and choose again.
- For your convenience you can remove this page while you answer Section A. **Remember to re-attach it** to the paper when you hand it in.

Question	a	b	c	d
1	X			
2			X	
3			X	
4	X			
5	X			
6				X
7				X
8	X			
9			X	
10			X	
11		X		
12			X	
13		X		
14				X
15		X		
<b>Totals</b>				
<b>Total Correct Section A</b>				

Total Marks Section A: ..... /xx

### END OF EXAMINATION

Name:.....

College:.....

## SECTION B – (20 Marks)

**INSTRUCTIONS:** Blank spaces in the following statements represent omissions. Write the appropriate word, words or information in the numbered spaces provided.

- Use AS/NZS 3000:2007 to best answer each question.
- Write clause or table numbers where required.

### QUESTION 1. (2 Marks)

Two methods for preventing live parts or parts separated from live parts by single insulation, from coming into contact with structural metalwork if a conductor was to break at a termination are:

*Restraining the conductor by tying, lacing or clipping; or containing the termination within a non-conductive shroud or enclosure.* \_\_\_\_  
(Clause number 5.4.6.1AB \_\_\_\_)

### QUESTION 2. (2 Marks)

What precautions are required when installing down-lights in a ceiling near loose fill thermal insulation materials?

*Where 'loose fill insulation' is used a barrier guard constructed of fire resistant material shall be provided and secured in position to maintain the necessary clearance* \_\_\_\_  
(Clause number 4.5.2.3, Fig 4.7\_\_)

### QUESTION 3. (2 Marks)

When selecting and installing an earthing arrangement, what function must the arrangement perform when carrying earth fault and earth leakage currents?

*Provide an effective and reliable low impedance fault path capable of carrying earth fault and leakage currents without danger or failure from thermal, electromechanical, mechanical, environmental and other external influences* \_\_\_\_\_  
(Clause number 5.1.2d \_\_\_\_)

### QUESTION 4. (2 Marks)

What value of current should be used when calculating voltage drop on a circuit?  
*total connected load supplied through the circuit, or the maximum demand, or the current rating of the protective device* \_\_\_\_\_  
(Clause number 3.6.2abc \_\_\_\_)

**QUESTION 5. (2 Marks)**

What types of thermoplastic cables are suitable for an installation operating at minus eight degrees?

HFI-75-TP, TPE-75, HFI-90-TP, TP-90

(Clause number T3.2 )

**QUESTION 6. (2 Marks)**

What are the requirements for installing a twenty metre run of rigid PVC conduit, not marked with the letter 'T', in direct sunlight where the temperature may vary between zero and forty degrees Celsius

paint with a light coloured water-based acrylic paint and allow for 80mm of expansion

(Clause number 3.10.3.7, 3.10.3.8 )

**QUESTION 7. (2 Marks)**

When the MEN connection is not made next to the main neutral conductor, what would be the requirements for identifying the main neutral and MEN connection at a bar or link?

The terminals for the MEN and main neutral shall be legibly and indelibly marked at the main neutral bar or link

(Clause number 2.9.5.4 )

**QUESTION 8. (2 Marks)**

What is the maximum length of unprotected interconnecting conductors from a solar electricity generation system?

15meters

(Clause number 7.3.5.1 )

**QUESTION 9. (2 Marks)**

Isolation switches operating in an AC motor supply circuit shall be capable of interrupting the locked rotor current. In the absence of any specific information supplied by the manufacturer, the locked rotor current shall be taken as?

8 times the locked rotor current for AC motors

4 times the locked rotor current for DC motors

(Clause number 4.13.1.2 )

**QUESTION 10. (2 Marks)**

What is the recommended maximum number of 2.5mm<sup>2</sup> two core and earth circular cables that may be installed in 40mm medium duty corrugated conduit?

*Three*

---

(Clause number \_\_\_\_\_ TC10 \_\_\_\_\_)

## SECTION C – (40 Marks)

**INSTRUCTIONS:** This section involves calculations. Show all necessary working in the space provided, marks will be awarded accordingly. Answers are to be highlighted or underlined.

### QUESTION 1. (4 Marks)

A three-phase distribution switchboard located in a commercial installation, comprising mainly single phase loads, has a maximum demand of 141 A per phase. Given that the sub-main into the distribution switchboard is a four-core R-EP-90 copper cable, which is installed touching a surface, determine:

- (a) The required current rating of the neutral conductor with AS/NZS3000 reference

Not less than the actives 141A

AS/NZS3000 reference 3.5.2iv

- (b) The size of the neutral conductor with the AS/NZS3008.1.1 reference

50mm<sup>2</sup>

AS/NZS3008.1.1 reference T14C5

**QUESTION 2. (6 Marks)**

A single phase domestic installation has the following load. Calculate the maximum demand for the installation

Room	Load
Kitchen	1 fitting with 6 x 9W lamps, 3 fittings with 1 x 9W ceiling fluorescent down lights, 1 x 15W pendant fluorescent lamp, 2 double SO, 1 single SO, 100W range hood, 4.6kW oven, 5.6kW hotplate
Dining	1 x 15W pendant fluorescent lamp, 3 fittings with 1 x 9W ceiling fluorescent down lights, 1 double SO
Family	5 x 9W ceiling fluorescent down lights, wall unit 5 x 9W fluorescent down lights, 4 double SO, 3kW Air. Con.
Laundry	1 x 9W lamp, 1 double SO, 400L off peak HWS with a 12 ohm 4.8kW 240V rated element
Toilet 1	1 x 9W lamp
Lounge	1 fitting with 3 x 9W lamps, 4 double SO
Foyer	1 fitting 3 x 9W lamps, 1 single SO
Porch	3 fittings with 1 x 9W lamps
Deck	1 weatherproof 300W quartz halogen lamp, 1 WP double SO
Bedrooms 1 to 3 (each room)	1 fitting with 3 x 9W lamps, 2 double SO
Master bedroom	1 fitting with 5 x 9W lamps, 4 double SO
Wardrobe	1 x 9W lamp
Hall 2	1 x 9W lamp, 1 single SO
Ensuite	1 x 9W lamp, 60W ceiling exhaust fan, 750W strip heater, 1 double SO
Bathroom	1 x 9W lamp, 60W ceiling exhaust fan, 2 x 375W heat lamps, 1 x 1800W spa heater, 1 x 750W spa pump
Vanity	1 x 9W lamp, 1 double SO
Toilet 2	1 x 9W lamp

Total lighting points	36+2
Total socket outlets	54+3=57

Load	Load Group	Calculation	Amps
Lighting	<b>Ai</b>	3+2	5
Exhaust fans	<b>Ai</b>	2 points	0
Lighting	<b>Ai</b>	$(300+375+375)/230$	4.6
Socket outlets	<b>Bi</b>	10+5+5	20
Cook-top oven	<b>C</b>	$4.6+5.6\text{kW}/230 \times 50\%$	22.2
Air-conditioner	<b>D</b>	$3000/230 \times 75\%$	9.8
Ensuite heater	<b>Bi</b>	1 additional point	0
Bath spa heater	<b>Bi</b>	1 additional point	0
Bath spa pump	<b>Bi</b>	1 additional point	0
Storage HWS	<b>F</b>	$I=V/R=230/12$	19.2
<b>Maximum Demand</b>			<b><u>80.8A</u></b>

Lose 1 mark for each incorrect line



**QUESTION 3. (6 Marks)**

**A multiple domestic installation comprises of 20 identical two bedroom units with dedicated undercover parking and one car wash bay. The installation also has a common BBQ area suitable for family picnics. The parking area and BBQ area are separately metered with one only *single phase meter on C phase*. Determine the maximum demand of the three phase 230/400V installation.**

**Each unit has the following associated load:**

- 32 lighting points
- 19 double socket outlets
- 4 single socket outlets
- 1 combination 2 lamp heater/light/exhaust fan unit 3.5A
- 1 combination 4 lamp heater/light/exhaust fan unit 6A
- Stiebel Eltron heat pump 300L HWS 3A
- Induction cook top 5.9kW
- Built in oven/grill 2.1kW max
- 3.0 hp air-conditioner 11.5A max

**The communal load associated with the installation is as follows**

- 1 automatic garage door motor 3.9A
- 20 garage lights each having a maximum rating of 60W
- 12 bollard lights each having a maximum rating of 60W
- 12 hall and stairwell lights having a maximum rating of 60W
- 24 socket outlets

LOAD	Load group	Calculation	Phase A	Phase B	Phase C
Lights	A	5+6x0.25 5+7x0.25	6.5	6.75	6.75
Socket outlets	Bi	15+3.75x6 15+3.75x7	37.5	41.25	41.25
Heat lamps	Bi	Included above	0	0	0
HWS	F	6x6 6x7	36	42	42
Cook top	C	2.8x6 2.8x7	16.8	19.6	19.6
Oven grill	C	Included above	0	0	0
Air conditioner	D	6x11.5x75% 7x11.5x75%	51.8	60.4	60.4
Communal lights	H	44x60/230	11.5		
Socket outlets	I	25 points	15		
Motor	L	FLA	3.9		
		<b>Total</b>	<b>179</b>	<b>170</b>	<b>170</b>

Maximum Demand = 179A

**QUESTION 4. (6 Marks)**

Calculate the maximum demand of three phase factory load listed below. All of the factory is heated with a 30kW gas heater. The supply is 230/400V

- 18 - 3.3A high bay lamps
- 36 - twin fluorescent lamps at 0.46A per fitting
- 4 – 300W quartz halogen lamps
- 2 – 400V 40A per phase, 3 phase motors
- 2 – 400V 23A per phase, 3 phase motors
- 2 – 400V 10 A per phase, 3 phase motors
- 3 - 2.9kW, 230V 50L quick recovery water heaters
- 2 - 2000kW, 230V instantaneous water heaters
- 10 - three phase 30A socket outlets
- 30 double 10A single phase socket outlets
- 22 single 10A single phase socket outlets

LOAD	Load group	Calculation	Phase A	Phase B	Phase C
Hi bay lights	A	6 x 3.3	19.8	19.8	19.8
Flouro lights	A	12 x 0.46	5.5	5.5	5.5
Halogen lights	A	300/230 = 1.3A/fitting	2.6	1.3	1.3
Motors 40A	D	40+40x0.75	70	70	70
Motors 23A	D	2x23x0.5	23	23	23
Motors 10A	D	2x10x0.5	10	10	10
2.9kW HWS	G	2900/230	12.6	12.6	12.6
2kW HWS	C	2000/230      2000/230 x 0.75	8.7	6.5	
Socket outlet 30A	Biii	30+9x30x0.75	232.5	232.5	232.5
Socket outlet 10A	Bii	A (1000+100x26)/230 B (1000+100x26)/230 C (1000+100x27)/230	15.7	15.7	16.1
<b>Total</b>			<b>400.4</b>	<b>396.9</b>	<b>390.8</b>

Maximum Demand = 400 A

Answers must be within 25A per phase

**QUESTION 5. (4 Marks)**

**A final sub-circuit to supply a single phase motor with a maximum demand of 22A and a route length of 42 metres is wired with 4mm<sup>2</sup>, TPS V90 flat multi-core copper cable installed in heavy duty PVC conduit. Calculate the voltage drop in the cable.**

$$Vd = Vc L I / 1000$$

$$Vd = 9.71 \times 1.155 \times 42 \times 22 / 1000$$

$$Vd = \underline{10.4 \text{volts}}$$

**Table 42 Col 6**

**QUESTION 6 (4 Marks)**

**A three phase sub-main to supply a factory consists of X90 SDI copper conductors installed in trefoil on a horizontal perforated cable tray touching two other sub-mains. The maximum demand of the factory is 212A.**

**(a) Determine the minimum acceptable size of the active conductors.**

$$\text{Derating} = 0.87 \quad \text{T23}$$

$$212 / 0.87 = 244 \text{A}$$

$$\text{Cable size} = 95 \text{mm}^2 \text{ T8C5}$$

**Size.....95mm<sup>2</sup> .....**

**References...3008.1.1 T8C5...**

**References....3008.1.1 T23.....**

**(b) Determine an acceptable size for the sub-main earth conductor**

**Size.....25mm<sup>2</sup> .....**

**References...AS3000 T5.1.....**

**QUESTION 7 (4 Marks)**

A 230V final sub-circuit is to be wired in 6 mm<sup>2</sup> V90, TPI conductors with a 4mm<sup>2</sup> earth to enable the circuit length to be increased. The circuit is protected by a 40A Type C circuit breaker and has a maximum demand of 34A. Determine the increased length obtained by using a 4mm<sup>2</sup> earth conductor instead of a 2.5mm<sup>2</sup> earth conductor with regard to fault loop impedance.

Table B1 with 2,5 earth length = 48metres

Eq B7  $L=0.8 \times 230 \times 6 \times 4 / (7.5 \times 40 \times 2.5 \times 10^{-3} \times 10)$

L=65.4m

65.4 - 48 =

Increased length = 17.4metres

**QUESTION 8**

**(6 Marks)**

The prospective short circuit current at the point of service for a 230/400V installation is 30kA.

(a) Determine the source impedance for the installation.

$$\begin{aligned} Z_{\text{source}} &= 230\text{V} / 30\text{kA} \\ &= 0.0077\text{ohms} \end{aligned}$$

$$Z_{\text{source}} = \underline{0.0077} \text{ ohms}$$

(b) If the consumers mains are 120mm<sup>2</sup> SDI V90 aluminium conductors and 35 metres long, determine the prospective short circuit current at the main switchboard.

T34 C9

$$Z_{\text{cable}} = 0.301 \times 35 / 1000 = 0.011\text{ohms}$$

$$\begin{aligned} I_{\text{fault}} &= V / Z_{\text{total}} = 230 / (0.0077 + 0.011) \\ &= 12.3\text{kA} \end{aligned}$$

Prospective short circuit current \_\_\_\_\_ 12.3kA

(c) If distribution board is fed by sub-mains, 120 metres long 50mm<sup>2</sup> multi-core V75 copper conductors, determine the prospective short circuit current at the DB.

T35 C4

$$Z_{\text{cable}} = 0.471 \times 120 / 1000 = 0.0565\text{ohms}$$

$$\begin{aligned} I_{\text{fault}} &= 230 / (0.0077 + 0.011 + 0.0565) \\ &= 3,058\text{A} \end{aligned}$$

Prospective short circuit current \_\_\_ 3kA

### SECTION D – (25 Marks)

**INSTRUCTION:** The question in this section requires some simple drawing. Ensure that the drawing is *neat and legible*. The use of pencil on the drawing is acceptable in this section only.

#### QUESTION 1. (4 Marks)

A domestic installation is supplied with parallel  $16\text{mm}^2$  unprotected consumers mains where double insulation is not maintained up to the service fuse and service neutral link. Complete the following tasks on Figure 2

- (a) On the main switchboard draw all cables used for earthing and identify any specific 'marking' requirements for the cables and or positions.
- (b) Mark next to the cables the minimum required size as specified in AS/NZS3000

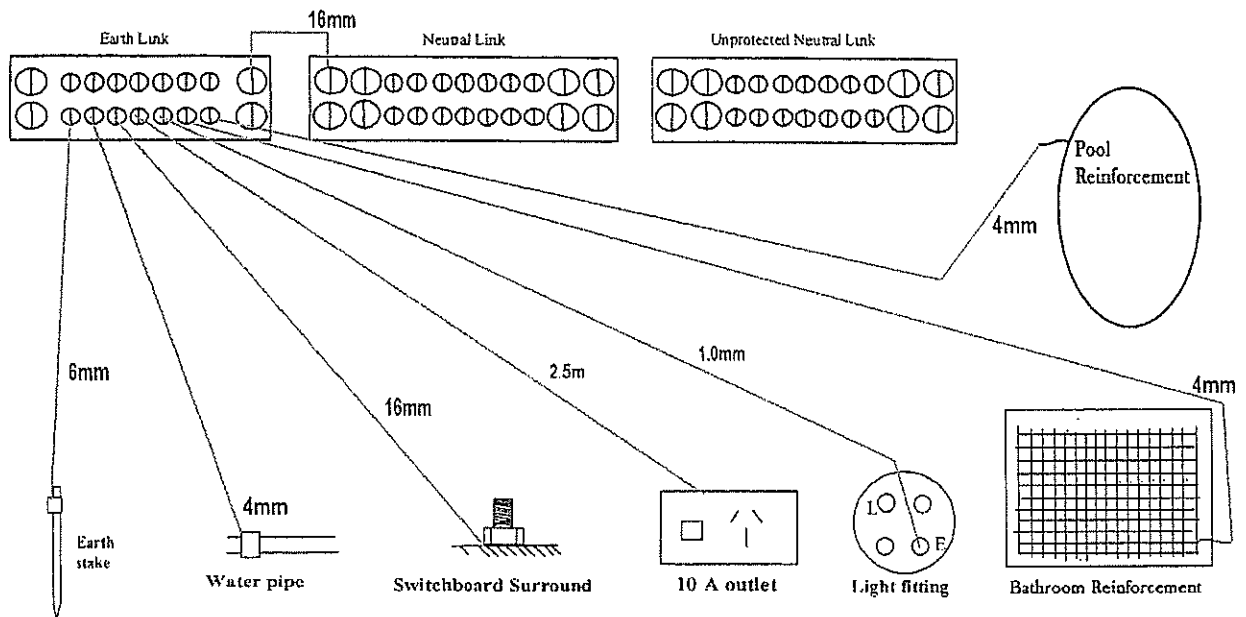
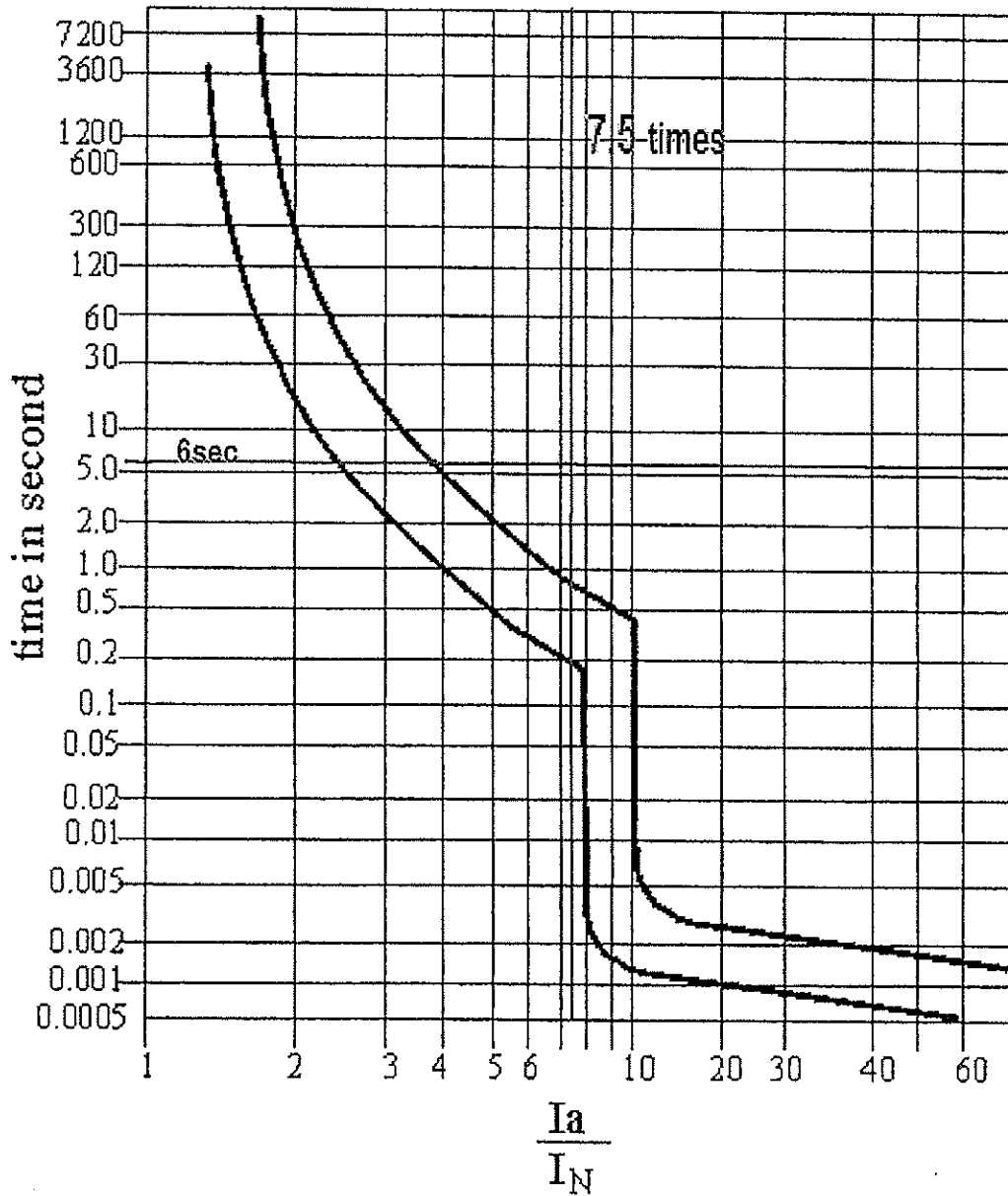

Figure 2

**QUESTION 2. (4 Marks)**

The suitability of a 32A type D circuit breaker having a tripping characteristic shown in Figure 3 to protect a circuit supplying a motor that takes 6 second to run up to speed and has a maximum starting current of 240A. Show all working and how you came to your answer from the diagram.



**Figure 3**

---

$$240/32=7.5$$

---

The motor starting current will cause the circuit breaker to operate during start up

---

---

Suitable / Unsuitable

---



**QUESTION 3. (4 Marks)**

A polarity test is to be performed on a final sub-circuit containing socket outlets. Record your results for the polarity test in the table below.

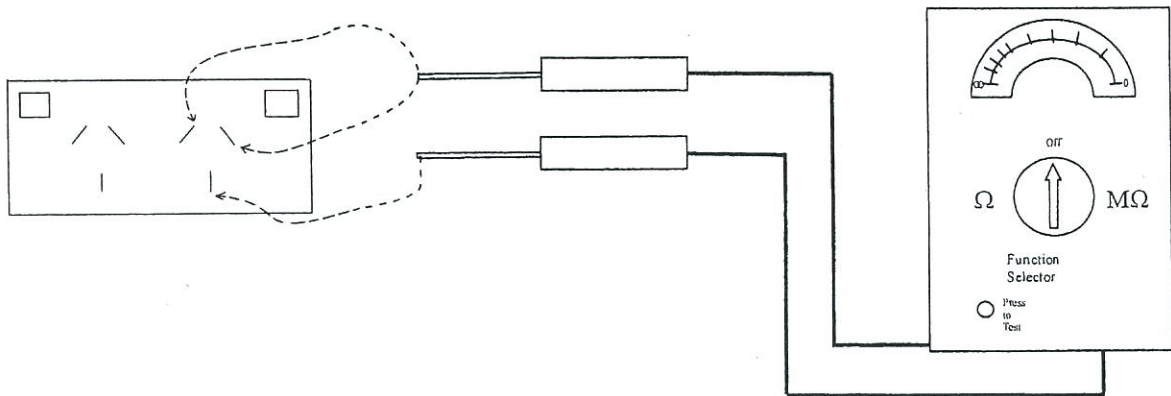
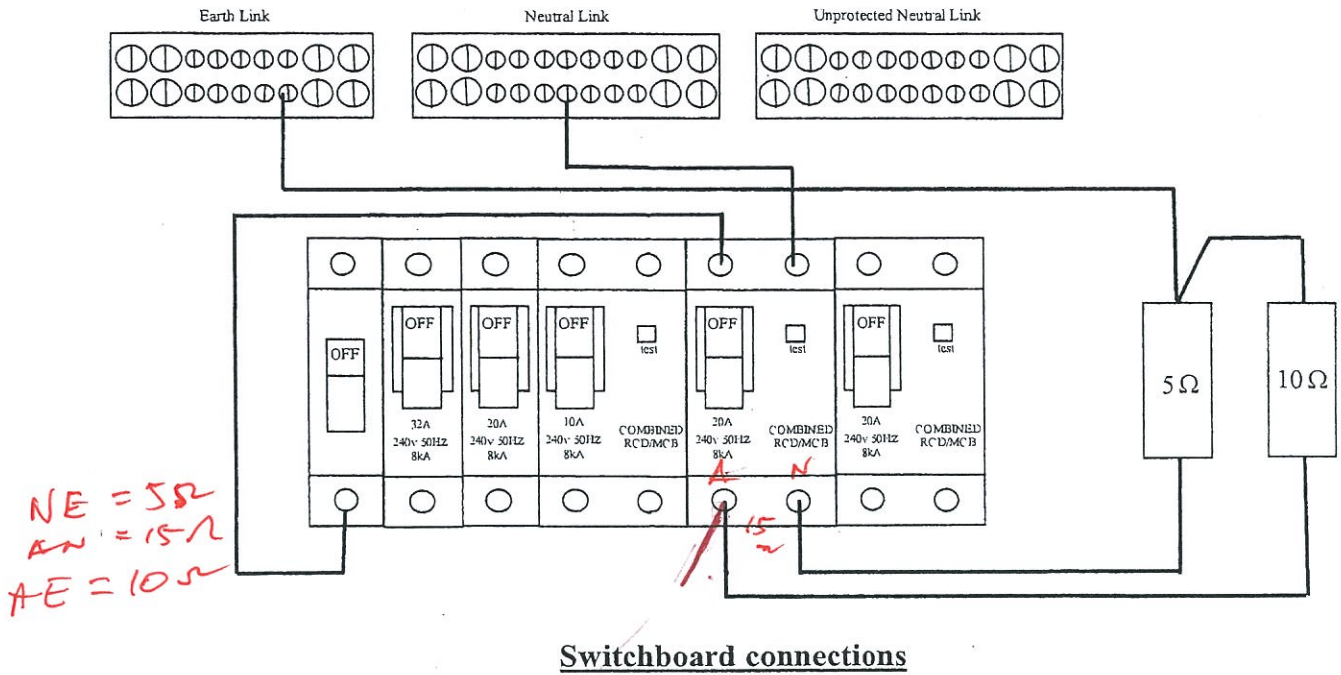

**Figure 4**

Select correct meter position, circle correct selection below,

3Ω, 500Ω, 250V, 500V, 1000V (1mark)

The results for correct polarity check would be: (3marks)

Combination	Result
Active-neutral	15Ω
Active- earth	10Ω
Neutral-earth	5Ω
Active-neutral Switched off	∞Ω
Active- earth Switched off	∞Ω
Neutral-earth switched off	5Ω

**QUESTION 4. (4 Marks)**

**Complete the required sections on the Certificate of Compliance – Electrical Work on the following page to satisfy the following. Note: Do NOT include any details for the electrician or tester.**

**Customer:** Malcolm Turnbull,  
77 Florida Drive,  
Canberra. 2299.

**Cross street:** Coronation Drive

**Meter number:** 11772

**Electrician:** Ignore any reference

**Installation details** Install 5 light points and 6 socket outlets to existing circuits for a small extension.

**Consumer mains:** Four by 16mm<sup>2</sup> SDI

**Main earth electrode:** 1meter to the left of the switchboard

**Water service equipotential bond:** At water pipe entry at front of building on switchboard side of building

**Test results:**

Insulation resistance:	Water heater	0.8 MΩ
	Range	0.4 MΩ
	Other circuits	Infinity
Earth continuity:	Main earth	0.1 Ω
	Equipotential bond	0.1 Ω
	All other	<0.4 Ω
All other tests:	Correct	

# CERTIFICATE OF COMPLIANCE – ELECTRICAL WORK

Customer COPY

CERTIFICATE NO: 000403

### CUSTOMER DETAILS

Name: M. TURNER

Address: \_\_\_\_\_

Cross Street: \_\_\_\_\_ Postcode: \_\_\_\_\_

Telephone Contact: \_\_\_\_\_

Meter No: 11 772

NMI (if applicable): \_\_\_\_\_

INSTALLATION WORK DETAILS Indicate the type of installation and types of work performed under this Notice					
Type of Installation	<input type="checkbox"/> Residential	<input type="checkbox"/> Commercial	<input type="checkbox"/> Industrial	<input type="checkbox"/> Rural	<input type="checkbox"/> Other
Special Conditions	<input type="checkbox"/> over 100 amps	<input type="checkbox"/> High Voltage	<input type="checkbox"/> Hazardous Area	<input type="checkbox"/> Generator	<input type="checkbox"/> Unmetered Supply

**CERTIFICATE MUST BE ISSUED TO THE CUSTOMER FOR ALL ELECTRICAL WORK**

Work of the following type must ALSO be notified to the ELECTRICITY DISTRIBUTOR (DNSP)

New Installation  Network connection or metering

Additions or alterations to a switchboard or associated equipment  Defect Rectification No:

**DETAILS OF EQUIPMENT** Describe the equipment and estimate load increase of the work affected by this Notice. If insufficient space attach separate sheets.

EQUIPMENT	RATING	No.	PARTICULARS OF WORK
<input type="checkbox"/> Switchboards			
<input type="checkbox"/> Circuits			
<input checked="" type="checkbox"/> Lighting	60W	5	
<input checked="" type="checkbox"/> Socket-outlets	10A	6	
<input type="checkbox"/> Appliances			
Estimated increase in load A/ph		Nil	<input checked="" type="checkbox"/> Increased load is within capacity of installation/service mains
<input checked="" type="checkbox"/> Work is connected to supply			<input type="checkbox"/> Work is not connected to supply pending inspection by DNSP

The work has been carried out or supervised by: \_\_\_\_\_ Licence No: \_\_\_\_\_

**TEST REPORT** Indicate the relevant tests and checks that have been performed on the work. If test records are provided attach as separate sheets.

<input checked="" type="checkbox"/> Earthing system integrity Ω	<input checked="" type="checkbox"/> Residual current device operation
<input checked="" type="checkbox"/> Insulation resistance MΩ	<input checked="" type="checkbox"/> Visual check that installation is suitable for connection to supply
<input checked="" type="checkbox"/> Polarity	<input type="checkbox"/> Stand-alone power system complies with AS 4509
<input checked="" type="checkbox"/> Correct circuit connections	<input type="checkbox"/> Fault loop impedance (if necessary)

I confirm that I have carried out the above tests and visually checked that the installation work described in this Certificate complies with AS/NZS 3000 and is suitable for its intended use.

Name: \_\_\_\_\_ Licence No: \_\_\_\_\_

Signature: \_\_\_\_\_ Date of Testing: \_\_\_\_\_

**CERTIFICATION**

I, the Electrical Contractor give notice to the Customer and \_\_\_\_\_ (Name of DNSP or OFT), that the work described in this Certificate has been completed in accordance with the Electricity (Consumer Safety) Regulation 2006

Name: \_\_\_\_\_ Licence No: \_\_\_\_\_

Signature: \_\_\_\_\_ Date of Notice: \_\_\_\_\_

Address: \_\_\_\_\_ Telephone No. or Other Contact: \_\_\_\_\_

**ELECTRICITY DISTRIBUTOR (DNSP) REMARKS**

Inspected by: \_\_\_\_\_ Date: \_\_\_\_\_

Comments: \_\_\_\_\_



**QUESTION 5. (4 Marks)**

The equipment shown below is for a distribution board for a single dwelling. The four final sub-circuits are to be connected using the breakers shown below. All the final sub-circuits are wired with V90 cable and partially surrounded by thermal insulation. Show on the diagram the necessary Active and Neutral connections to supply these circuits.

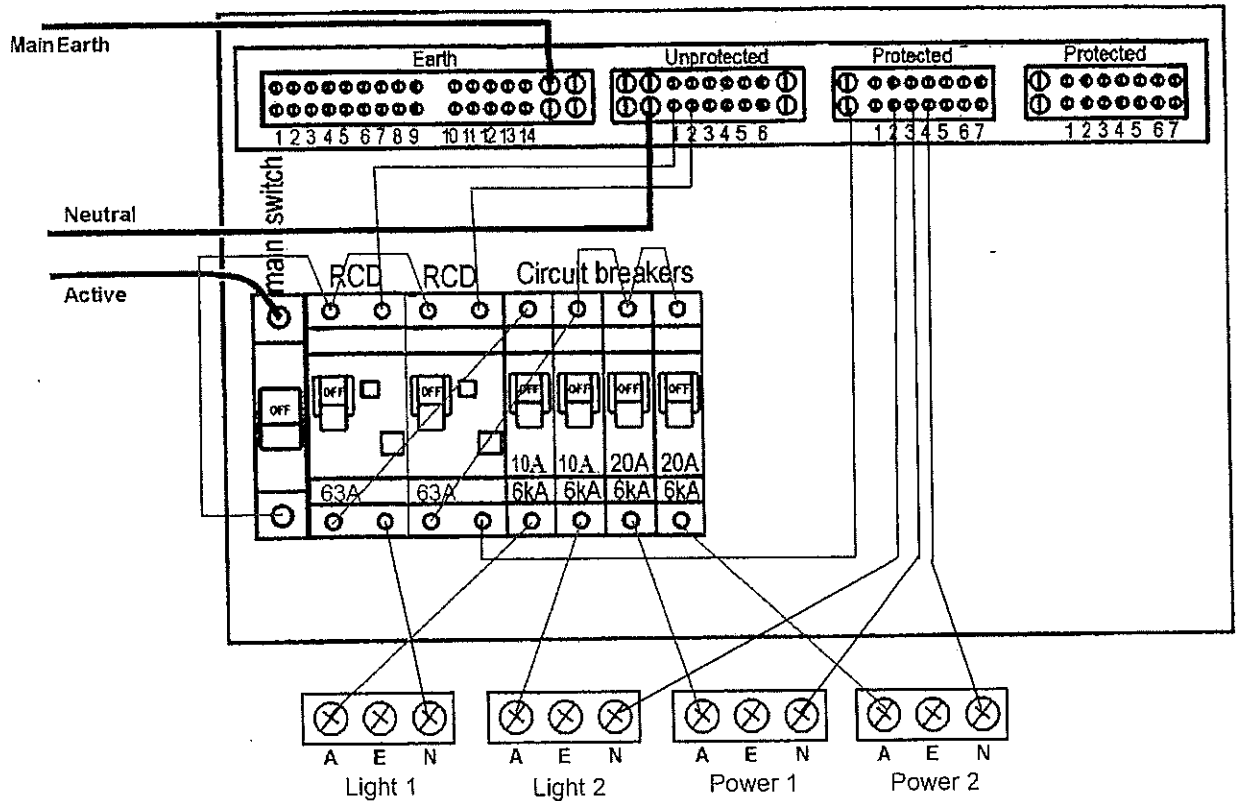

**Figure 5**

**QUESTION 6. (5 Marks)**

List the procedure for performing an insulation resistance test on the whole installation for Question 5 above.

\_\_\_ Test that the supply is off \_\_\_ Disconnect the MEN \_\_\_ Connect the active and neutral together \_\_\_ Set the insulation tester to 500V \_\_\_ With all breakers and switches on, test active to earth to obtain a reading greater than 1Meg ohm

---

---

---

---

---

---

---

---

---

---



Note: The symbols used on this sheet follow AS1046 pt 1. There are alternate recognised symbols in use. The list does not contain every equation used in the course. Transposition of equations will be necessary to solve problems

$Q = It$	$v = \frac{s}{t}$	$a = \frac{\Delta v}{t}$
$F = ma$	$W = Fs$	$W = mgh$
$W = Pt$	$\eta\% = \frac{\text{output}}{\text{input}} \times \frac{100}{1}$	$I = \frac{V}{R}$
$P = VI$	$P = I^2R$	$P = \frac{V^2}{R}$
$R_2 = \frac{R_1 A_1 l_2}{A_2 l_1}$	$R_h = R_c(1 + \alpha \Delta t)$	$R = \frac{\rho l}{A}$
$R_T = R_1 + R_2 + R_3$	$V_T = V_1 + V_2 + V_3$	$\frac{1}{R_T} = \frac{1}{R_1} + \frac{1}{R_2} + \frac{1}{R_3}$
$I_T = I_1 + I_2 + I_3$	$V_2 = V_T \frac{R_2}{R_1 + R_2}$	$I_2 = I_T \frac{R_1}{R_1 + R_2}$
$R_x = \frac{R_A R}{R_B}$	$C = \frac{Q}{V}$	$\tau = RC$
$\frac{1}{C_T} = \frac{1}{C_1} + \frac{1}{C_2} + \frac{1}{C_3}$	$C_T = C_1 + C_2 + C_3$	$C = \frac{A \epsilon_0 \epsilon_r}{d}$
$F_m = IN$	$H = \frac{F_m}{l}$	$B = \frac{\Phi}{A}$
$\Phi = \frac{F_m}{S}$	$S = \frac{l}{\mu_0 \mu_r A}$	$V = N \frac{\Delta \Phi}{\Delta t}$
$e = Blv$	$L = \frac{\mu_0 \mu_r AN^2}{l}$	$L = N \frac{\Delta \Phi}{\Delta I}$
$V = L \frac{\Delta I}{\Delta t}$	$\tau = \frac{L}{R}$	$F = Bil$
$T = Fr$	$E_g = \frac{\Phi Z n P}{60 a}$	$P = \frac{2\pi n T}{60}$
$t = \frac{1}{f}$	$f = \frac{np}{120}$	$V = 0.707V_{\max}$
$I = 0.707I_{\max}$	$V_{\text{ave}} = 0.637V_{\max}$	$I_{\text{ave}} = 0.637I_{\max}$
$v = V_{\max} \sin \phi$	$i = I_{\max} \sin \phi$	$I = \frac{V}{Z}$
$Z = \sqrt{R^2 + (X_L - X_C)^2}$	$X_L = 2\pi fL$	$X_C = \frac{1}{2\pi fC}$
$\cos \phi = \frac{P}{S}$	$\cos \phi = \frac{R}{Z}$	$S = \sqrt{P^2 + Q^2}$
$S = VI$	$P = VI \cos \phi$	$Q = VI \sin \phi$

$$f_o = \frac{1}{2\pi\sqrt{LC}}$$

$$V_L = \sqrt{3}V_P$$

$$I_L = \sqrt{3}I_P$$

$$S = \sqrt{3}V_L I_L$$

$$P = \sqrt{3}V_L I_L \cos\phi$$

$$Q = \sqrt{3}V_L I_L \sin\phi$$

$$\tan\phi = \sqrt{3}\left(\frac{W_2 - W_1}{W_2 + W_1}\right)$$

$$Q = mC\Delta t$$

$$V' = 4.44\Phi f N$$

$$\frac{V_1}{V_2} = \frac{N_1}{N_2}$$

$$\frac{I_2}{I_1} = \frac{N_1}{N_2}$$

$$N_{syn} = \frac{120f}{p}$$

$$s\% = \frac{(n_{syn} - n)}{n_{syn}} \times \frac{100}{1}$$

$$f_r = \frac{s\% \times f}{100}$$

$$V_{reg}\% = \frac{(V_{NL} - V_{FL})}{V_{FL}} \times \frac{100}{1}$$

$$V_{reg}\% = \frac{(V_{NL} - V_{FL})}{V_{NL}} \times \frac{100}{1}$$

$$T = \frac{\Phi Z I P}{2\pi a}$$

$$I_{ST} = \frac{1}{3} \times I_{DOL}$$

$$T_{ST} = \frac{1}{3} \times T_{DOL}$$

$$I_{ST} = \frac{V_{ST}}{V} \times I_{DOL}$$

$$T_{ST} = \left(\frac{V_{ST}}{V}\right)^2 \times T_{DOL}$$

$$I_{motor\ st} = \frac{\%TAP}{100} \times I_{DOL}$$

$$I_{line\ st} = \left(\frac{\%TAP}{100}\right)^2 \times I_{DOL}$$

$$E = \frac{\Phi_v}{A}$$

$$E = \frac{I}{d^2}$$

$$\eta_v = \frac{\Phi_v}{P}$$

$$V_L = 0.45V_{ac}$$

$$V_L = 0.9V_{ac}$$

$$V_L = 1.17V_{phase}$$

$$V_L = 1.35V_{line}$$

$$PRV = \sqrt{2}V_{ac}$$

$$PRV = 2\sqrt{2}V_{ac}$$

$$PRV = 2.45V_{ac}$$

$$V_{ripple} = \sqrt{2}V_{ac}$$

$$V_{ripple} = 0.707V_{phase}$$

$$V_{ripple} = 0.1895V_{line}$$