

# Refrigeration & Air conditioning



**40 LESSONS ON REFRIGERATION AND AIR CONDITIONING FROM IIT KHARAGPUR. USEFUL TRAINING MATERIAL FOR MECHANICAL ENGINEERING STUDENTS/COLLEGE, OR AS REFERENCE FOR ENGINEER.**



**EE IIT, Kharagpur, India**

**2008**

## Contents:

<b>Lesson</b>	<b>Page</b>
<b>Lesson 1 History Of Refrigeration</b> [ Natural Refrigeration ~ Artificial Refrigeration ]	<b>7</b>
<b>Lesson 2 History Of Refrigeration - Development Of Refrigerants And Compressors</b> [ Refrigerant development - a brief history ~ Compressor development - a brief history ]	<b>26</b>
<b>Lesson 3 Applications Of Refrigeration &amp; Air Conditioning</b> [ Application of refrigeration in Food processing, preservation and distribution ~ Applications of refrigeration in chemical and process industries ~ Special applications of refrigeration ~ Application of air conditioning ]	<b>44</b>
<b>Lesson 4 Review of fundamental principles - Thermodynamics : Part I</b> [ Definitions ~ Thermodynamic properties ~ Fundamental laws of Thermodynamics ]	<b>64</b>
<b>Lesson 5 Review of fundamental principles - Thermodynamics : Part II</b> [ Thermodynamic relations ~ Evaluation of thermodynamic properties ~ Thermodynamic processes ]	<b>78</b>
<b>Lesson 6 Review of fundamentals: Fluid flow</b> [ Fluid flow ]	<b>93</b>
<b>Lesson 7 Review of fundamentals: Heat and Mass transfer</b> [ Heat transfer ~ Fundamentals of Mass transfer ~ Analogy between heat, mass and momentum transfer ~ Multimode heat transfer ~ Heat exchangers ]	<b>104</b>
<b>Lesson 8 Methods of producing Low Temperatures</b> [ Sensible cooling by cold medium ~ Endothermic mixing of substances ~ Phase change processes ~ Expansion of Liquids ~ Expansion of gases ~ Thermoelectric Refrigeration ~ Adiabatic demagnetization ]	<b>124</b>
<b>Lesson 9 Air cycle refrigeration systems</b> [ Air Standard Cycle analysis ~ Basic concepts ~ Reversed Carnot cycle employing a gas ~ Ideal reverse Brayton cycle ~ Aircraft cooling systems ]	<b>138</b>

<b>Lesson 10 Vapour Compression Refrigeration Systems</b> [ Comparison between gas cycles and vapor cycles ~ Vapour Compression Refrigeration Systems ~ The Carnot refrigeration cycle ~ Standard Vapour Compression Refrigeration System (VCRS) ~ Analysis of standard vapour compression refrigeration system ]	<b>153</b>
<b>Lesson 11 Vapour Compression Refrigeration Systems: Performance Aspects And Cycle Modifications</b> [ Performance of SSS cycle ~ Modifications to SSS cycle ~ Effect of superheat on system COP ~ Actual VCRS systems ~ Complete vapour compression refrigeration systems ]	<b>171</b>
<b>Lesson 12 Multi-Stage Vapour Compression Refrigeration Systems</b> [ Flash gas removal using flash tank ~ Intercooling in multi-stage compression ~ Multi-stage system with flash gas removal and intercooling ~ Use of flash tank for flash gas removal ~ Use of flash tank for intercooling only ]	<b>193</b>
<b>Lesson 13 Multi-Evaporator And Cascade Systems</b> [ Individual evaporators and a single compressor with a pressure-reducing valve ~ Multi-evaporator system with multi-compression, intercooling and flash gas removal ~ Multi-evaporator system with individual compressors and multiple expansion valves ~ Limitations of multi-stage systems ~ Cascade Systems ]	<b>213</b>
<b>Lesson 14 Vapour Absorption Refrigeration Systems</b> [ Maximum COP of ideal absorption refrigeration system ~ Properties of refrigerant-absorbent mixtures ~ Basic Vapour Absorption Refrigeration System ~ Refrigerant-absorbent combinations for VARS ]	<b>238</b>
<b>Lesson 15 Vapour Absorption Refrigeration Systems Based On Water-Lithium Bromide Pair</b> [ Properties of water-lithium bromide solutions ~ Steady flow analysis of Water-Lithium Bromide Systems ~ Practical problems in water-lithium bromide systems ~ Commercial systems ~ Heat sources for water-lithium bromide systems ~ Minimum heat source temperatures for LiBr-Water systems ~ Capacity control ]	<b>258</b>
<b>Lesson 16 Vapour Absorption Refrigeration Systems Based On Ammonia-Water Pair</b> [ Properties of ammonia-water solutions ~ Basic Steady-Flow Processes with binary mixtures ]	<b>279</b>
<b>Lesson 17 Vapour Absorption Refrigeration Systems Based On Ammonia-Water Pair</b> [ Working principle ~ Principle of rectification column and dephlegmator ~ Steady-flow analysis of the system ~ Pumpless vapour absorption refrigeration systems ~ Solar energy driven sorption systems ~ Comparison between compression and absorption refrigeration systems ]	<b>301</b>

---

<b>Lesson 18 Refrigeration System Components: Compressors</b> [ Compressors ~ Reciprocating compressors ]	<b>317</b>
<b>Lesson 19 Performance Of Reciprocating Compressors</b> [ Ideal compressor with clearance ~ Actual compression process ~ Capacity control of reciprocating compressors ~ Compressor lubrication ]	<b>337</b>
<b>Lesson 20 Rotary, Positive Displacement Type Compressors</b> [ Rolling piston (fixed vane) type compressors ~ Multiple vane type compressors ~ Characteristics of rotary, vane type compressors ~ Rotary, screw compressors ~ Scroll compressors ]	<b>361</b>
<b>Lesson 21 Centrifugal Compressors</b> [ Analysis of centrifugal compressors ~ Selection of impeller Speed and impeller diameter ~ Refrigerant capacity of centrifugal compressors ~ Performance aspects of centrifugal compressor ~ Commercial refrigeration systems with centrifugal compressors ]	<b>376</b>
<b>Lesson 22 Condensers &amp; Evaporators</b> [ Condensers ~ Classification of condensers ~ Analysis of condensers ~ Optimum condenser pressure for lowest running cost ]	<b>402</b>
<b>Lesson 23 Condensers &amp; Evaporators</b> [ Classification ~ Natural Convection type evaporator coils ~ Flooded Evaporator ~ Shell-and-Tube Liquid Chillers ~ Shell-and-Coil type evaporator ~ Double pipe type evaporator ~ Baudelot type evaporators ~ Direct expansion fin-and-tube type ~ Plate Surface Evaporators ~ Plate type evaporators ~ Thermal design of evaporators ~ Enhancement of heat transfer coefficients ~ Wilson's plot ]	<b>439</b>
<b>Lesson 24 Expansion Devices</b> [ Capillary Tube ~ Automatic Expansion Valve (AEV) ~ Flow Rate through orifice ~ Thermostatic Expansion Valve (TEV) ~ Float type expansion valves ~ Electronic Type Expansion Valve ~ Practical problems in operation of Expansion valves ]	<b>465</b>
<b>Lesson 25 Analysis Of Complete Vapour Compression Refrigeration Systems</b> [ Reciprocating compressor performance characteristics ~ Evaporator Performance ~ Expansion valve Characteristics ~ Condensing unit ~ Performance of complete system - condensing unit and evaporator ~ Effect of expansion valve ]	<b>504</b>
<b>Lesson 26 Refrigerants</b> [ Primary and secondary refrigerants ~ Refrigerant selection criteria ~ Designation of refrigerants ~ Comparison between different refrigerants ]	<b>523</b>

---

<b>Lesson 27 Psychrometry</b> [ Methods for estimating properties of moist air ~ Measurement of psychrometric properties ~ Calculation of psychrometric properties from p, DBT and WBT ~ Psychrometer ]	<b>537</b>
<b>Lesson 28 Psychrometric Processes</b> [ Important psychrometric processes ~ Air Washers ~ Enthalpy potential ]	<b>553</b>
<b>Lesson 29 Inside And Outside Design Conditions</b> [ Selection of inside design conditions ~ Thermal comfort ~ Heat balance equation for a human being ~ Factors affecting thermal comfort ~ Indices for thermal comfort ~ Predicted Mean Vote (PMV) and Percent People Dissatisfied (PPD) ~ Selection of outside design conditions ]	<b>572</b>
<b>Lesson 30 Psychrometry Of Air Conditioning Systems</b> [ Summer air conditioning systems ~ Guidelines for selection of supply state and cooling coil ]	<b>591</b>
<b>Lesson 31 Evaporative, Winter And All Year Air Conditioning Systems</b> [ Introduction to evaporative air conditioning systems ~ Classification of evaporative cooling systems ~ Advantages and disadvantages of evaporative cooling systems ~ Applicability of evaporative cooling systems ~ Winter Air Conditioning Systems ~ All year (complete) air conditioning systems ~ ]	<b>608</b>
<b>Lesson 32 Cooling And Heating Load Calculations - Estimation Of Solar Radiation</b> [ Solar radiation ~ Calculation of direct, diffuse and reflected radiations ]	<b>626</b>
<b>Lesson 33 Cooling And Heating Load Calculations -Solar Radiation Through Fenestration - Ventilation And Infiltration</b> [ Solar radiation through fenestration ~ Estimation of solar radiation through fenestration ~ Effect of external shading ~ Ventilation for Indoor Air Quality (IAQ) ~ Infiltration ~ Heating and cooling loads due to ventilation and infiltration ]	<b>645</b>
<b>Lesson 34 Cooling And Heating Load Calculations - Heat Transfer Through Buildings - Fabric Heat Gain/Loss</b> [ One-dimensional, steady state heat transfer through buildings ~ Unsteady heat transfer through opaque walls and roofs ~ One-dimensional, unsteady heat transfer through building walls and roof ]	<b>660</b>
<b>Lesson 35 Cooling And Heating Load Calculations - Estimation Of Required Cooling/Heating Capacity</b> [ Heating versus cooling load calculations ~ Methods of estimating cooling and heating loads ~ Cooling load calculations ~ Estimation of the cooling capacity of the system ~ Heating load calculations ~ ]	<b>688</b>

---

---

<b>Lesson 36 Selection Of Air Conditioning Systems</b> [ Selection criteria for air conditioning systems ~ Classification of air conditioning systems ~ All water systems ~ Air-water systems ~ Unitary refrigerant based systems ]	<b>709</b>
<b>Lesson 37 Transmission Of Air In Air Conditioning Ducts</b> [ Transmission of air ~ Flow of air through ducts ~ Estimation of pressure loss in ducts ~ Dynamic losses in ducts ~ Static Regain ]	<b>734</b>
<b>Lesson 38 Design Of Air Conditioning Ducts</b> [ General rules for duct design ~ Classification of duct systems ~ Commonly used duct design methods ~ Performance of duct systems ~ System balancing and optimization ~ Fans ]	<b>752</b>
<b>Lesson 39 Space Air Distribution</b> [ Design of air distribution systems ~ Behaviour of free-stream jet ~ Circular jets ~ Types of air distribution devices ~ Return air inlets ~ Airflow patterns inside conditioned space ~ Stratified mixing flow ~ Spot cooling/heating ~ Selection of supply air outlets ]	<b>772</b>
<b>Lesson 40 Ventilation For Cooling</b> [ Natural versus mechanical ventilation ~ Natural ventilation ~ Guidelines for natural ventilation ~ Forced ventilation using electric fans ~ Interior air movement ]	<b>797</b>
<b>Reference books for this course</b>	<b>809</b>

---

# Lesson

1

# History Of Refrigeration

## Objectives of the lesson:

The objectives of this lesson are to:

1. Define refrigeration and air conditioning (*Section 1.1*)
2. Introduce aspects of various natural refrigeration methods, namely:
  - a. Use of ice transported from colder regions (*Section 1.2*)
  - b. Use of ice harvested in winter and stored in ice houses (*Section 1.2*)
  - c. Use of ice produced by nocturnal cooling (*Section 1.2.1*)
  - d. Use of evaporative cooling (*Section 1.2.2*)
  - e. Cooling by salt solutions (*Section 1.2.3*)
3. Introduce historical aspects of various artificial refrigeration methods, namely:
  - a. Vapour compression refrigeration systems, including
    - i. Domestic refrigeration systems (*Section 1.3.1.1*)
    - ii. Air conditioning systems (*Section 1.3.1.2*)
  - b. Vapour absorption refrigeration systems (*Section 1.3.2*)
  - c. Solar energy based refrigeration systems (*Section 1.3.3*)
  - d. Air cycle refrigeration systems (*Section 1.3.4*)
  - e. Steam and vapor jet refrigeration systems (*Section 1.3.5*)
  - f. Thermoelectric refrigeration systems (*Section 1.3.6*), and
  - g. Vortex tubes (*Section 1.3.7*)

At the end of the lesson the student should be able to:

1. Identify various natural and artificial methods of refrigeration
2. List salient points of various refrigeration techniques, and
3. Name important landmarks in the history of refrigeration

### 1.1. Introduction

Refrigeration may be defined as the process of achieving and maintaining a temperature below that of the surroundings, the aim being to cool some product or space to the required temperature. One of the most important applications of refrigeration has been the preservation of perishable food products by storing them at low temperatures. Refrigeration systems are also used extensively for providing thermal comfort to human beings by means of air conditioning. Air Conditioning refers to the treatment of air so as to simultaneously control its temperature, moisture content, cleanliness, odour and circulation, as required by occupants, a process, or products in the space. The subject of refrigeration and air conditioning has evolved out of human need for food and comfort, and its history dates back to centuries. The history of refrigeration is very interesting since every aspect of it, the availability of [refrigerants](#), the [prime movers](#) and the developments in [compressors](#) and the methods of refrigeration all are a part of it. The French scientist Roger ThÝvenot has written an excellent book on the history of refrigeration throughout the world. Here we present only a



brief history of the subject with special mention of the pioneers in the field and some important events.

**Q:** Which of the following can be called as a refrigeration process?

- a) Cooling of hot ingot from 1000°C to room temperature
- b) Cooling of a pot of water by mixing it with a large block of ice
- c) Cooling of human beings using a ceiling fan
- d) Cooling of a hot cup of coffee by leaving it on a table
- e) Cooling of hot water by mixing it with tap water
- f) Cooling of water by creating vacuum over it

**Ans:** b) and f)

## 1.2. Natural Refrigeration

In olden days refrigeration was achieved by natural means such as the use of ice or evaporative cooling. In earlier times, ice was either:

1. Transported from colder regions,
2. Harvested in winter and stored in ice houses for summer use or,
3. Made during night by cooling of water by [radiation](#) to [stratosphere](#).

In Europe, America and Iran a number of icehouses were built to store ice. Materials like sawdust or wood shavings were used as insulating materials in these icehouses. Later on, cork was used as insulating material. Literature reveals that ice has always been available to aristocracy who could afford it. In India, the Mogul emperors were very fond of ice during the harsh summer in Delhi and Agra, and it appears that the ice used to be made by nocturnal cooling.

In 1806, Frederic Tudor, (who was later called as the “ice king”) began the trade in ice by cutting it from the Hudson River and ponds of Massachusetts and exporting it to various countries including India. In India Tudor’s ice was cheaper than the locally manufactured ice by nocturnal cooling. The ice trade in North America was a flourishing business. Ice was transported to southern states of America in train compartments insulated by 0.3m of cork insulation. Trading in ice was also popular in several other countries such as Great Britain, Russia, Canada, Norway and France. In these countries ice was either transported from colder regions or was harvested in winter and stored in icehouses for use in summer. The ice trade reached its peak in 1872 when America alone exported 225000 tonnes of ice to various countries as far as China and Australia. However, with the advent of artificial refrigeration the ice trade gradually declined.

### 1.2.1. Art of Ice making by Nocturnal Cooling:

The art of making ice by nocturnal cooling was perfected in India. In this method ice was made by keeping a thin layer of water in a shallow earthen tray, and then exposing the tray to the night sky. Compacted hay of about 0.3 m thickness was used as insulation. The water loses heat by [radiation](#) to the [stratosphere](#), which is at around -55°C and by early morning hours the water in the trays freezes to ice. This method of ice production was very popular in India.

### 1.2.2. Evaporative Cooling:

As the name indicates, evaporative cooling is the process of reducing the temperature of a system by evaporation of water. Human beings perspire and dissipate their metabolic heat by evaporative cooling if the ambient temperature is more than skin temperature. Animals such as the hippopotamus and buffalo coat themselves with mud for evaporative cooling. Evaporative cooling has been used in India for centuries to obtain cold water in summer by storing the water in earthen pots. The water permeates through the pores of earthen vessel to its outer surface where it evaporates to the surrounding, absorbing its [latent heat](#) in part from the vessel, which cools the water. It is said that Patliputra University situated on the bank of river Ganges used to induce the evaporative-cooled air from the river. Suitably located chimneys in the rooms augmented the upward flow of warm air, which was replaced by cool air. Evaporative cooling by placing wet straw mats on the windows is also very common in India. The straw mat made from “khus” adds its inherent perfume also to the air. Now-a-days [desert coolers](#) are being used in hot and dry areas to provide cooling in summer.

### 1.2.3. Cooling by Salt Solutions:

Certain substances such as common salt, when added to water dissolve in water and absorb its heat of solution from water (endothermic process). This reduces the temperature of the solution (water+salt). Sodium Chloride salt (NaCl) can yield temperatures up to  $-20^{\circ}\text{C}$  and Calcium Chloride ( $\text{CaCl}_2$ ) up to  $-50^{\circ}\text{C}$  in properly insulated containers. However, as it is this process has limited application, as the dissolved salt has to be recovered from its solution by heating.

**Q.** The disadvantages of natural refrigeration methods are:

- a) They are expensive
- b) They are uncertain
- c) They are not environment friendly
- d) They are dependent on local conditions

**Ans:** b) and d)

**Q.** Evaporative cooling systems are ideal for:

- a) Hot and dry conditions
- b) Hot and humid conditions
- c) Cold and humid conditions
- d) Moderately hot but humid conditions

**Ans:** a)

## 1.3. Artificial Refrigeration

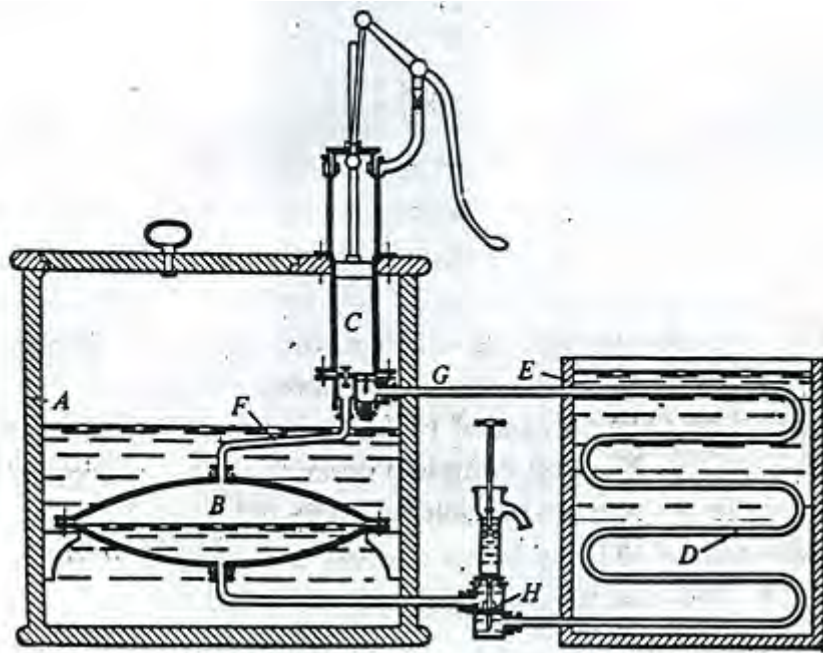
Refrigeration as it is known these days is produced by artificial means. Though it is very difficult to make a clear demarcation between natural and artificial refrigeration, it is generally agreed that the history of artificial refrigeration began in the year 1755, when the Scottish professor [William Cullen](#) made the first refrigerating machine, which could produce a small quantity of ice in the laboratory. Based on the working principle, refrigeration systems can be classified as vapour compression systems, vapour absorption systems, gas cycle systems etc.

### 1.3.1. Vapour Compression Refrigeration Systems:

The basis of modern refrigeration is the ability of liquids to absorb enormous quantities of heat as they boil and evaporate. Professor [William Cullen](#) of the University of Edinburgh demonstrated this in 1755 by placing some water in thermal contact with ether under a receiver of a vacuum pump. The evaporation rate of ether increased due to the vacuum pump and water could be frozen. This process involves two thermodynamic concepts, the vapour pressure and the [latent heat](#). A liquid is in thermal equilibrium with its own vapor at a pressure called the [saturation pressure](#), which depends on the temperature alone. If the pressure is increased for example in a pressure cooker, the water boils at higher temperature. The second concept is that the evaporation of liquid requires latent heat during evaporation. If latent heat is extracted from the liquid, the liquid gets cooled. The temperature of ether will remain constant as long as the vacuum pump maintains a pressure equal to saturation pressure at the desired temperature. This requires the removal of all the vapors formed due to vaporization. If a lower temperature is desired, then a lower saturation pressure will have to be maintained by the vacuum pump. The component of the modern day refrigeration system where cooling is produced by this method is called *evaporator*.

If this process of cooling is to be made continuous the vapors have to be recycled by condensation to the liquid state. The condensation process requires heat rejection to the surroundings. It can be condensed at atmospheric temperature by increasing its pressure. The process of condensation was learned in the second half of eighteenth century. U.F. Clouet and G. Monge liquefied  $\text{SO}_2$  in 1780 while van Marum and Van Troostwijk liquefied  $\text{NH}_3$  in 1787. Hence, a compressor is required to maintain a high pressure so that the evaporating vapours can condense at a temperature greater than that of the surroundings.

[Oliver Evans](#) in his book “Abortion of a young Steam Engineer’s Guide” published in Philadelphia in 1805 described a closed refrigeration cycle to produce ice by ether under vacuum. [Jacob Perkins](#), an American living in London actually designed such a system in 1835. The apparatus described by Jacob Perkins in his patent specifications of 1834 is shown in Fig.1.1. In his patent he stated “I am enabled to use volatile fluids for the purpose of producing the cooling or freezing of fluids, and yet at the same time constantly condensing such volatile fluids, and bringing them again into operation without waste”.



*Fig. 1.1. Apparatus described by Jacob Perkins in his patent specification of 1834. The refrigerant (ether or other volatile fluid) boils in evaporator B taking heat from surrounding water in container A. The pump C draws vapour away and compresses it to higher pressure at which it can condense to liquids in tubes D, giving out heat to water in vessel E. Condensed liquid flows through the weight loaded valve H, which maintains the difference of pressure between the condenser and evaporator. The small pump above H is used for charging the apparatus with refrigerant.*

John Hague made Perkins's design into working model with some modifications. This Perkins machine is shown in Fig.1.2. The earliest vapour compression system used either sulphuric (ethyl) or methyl ether. The American engineer Alexander Twining (1801-1884) received a British patent in 1850 for a vapour compression system by use of ether,  $\text{NH}_3$  and  $\text{CO}_2$ .

The man responsible for making a practical vapor compression refrigeration system was [James Harrison](#) who took a patent in 1856 for a vapour compression system using ether, alcohol or ammonia. [Charles Tellier](#) of France patented in 1864, a refrigeration system using dimethyl ether which has a normal boiling point of  $-23.6^\circ\text{C}$ .



*Fig.1.2. Perkins machine built by John Hague*

Carl von Linde in Munich introduced double acting ammonia compressor. It required pressures of more than 10 atmospheres in the condenser. Since the normal boiling point of ammonia is  $-33.3^{\circ}\text{C}$ , vacuum was not required on the low pressure side. Since then ammonia is used widely in large refrigeration plants.

[David Boyle](#), in fact made the first  $\text{NH}_3$  system in 1871 in San Francisco. John Enright had also developed a similar system in 1876 in Buffalo N.Y. Franz Windhausen developed carbon dioxide ( $\text{CO}_2$ ) based vapor compression system in Germany in 1886. The carbon dioxide compressor requires a pressure of about 80 atmospheres and therefore a very heavy construction. Linde in 1882 and T.S.C. Lowe in 1887 tried similar systems in USA. The  $\text{CO}_2$  system is a very safe system and was used in ship refrigeration until 1960s. [Raoul Pictet](#) used  $\text{SO}_2$  (NBP  $-10^{\circ}\text{C}$ ) as refrigerant. Its lowest pressure was high enough to prevent the leakage of air into the system.

Palmer used  $\text{C}_2\text{H}_5\text{Cl}$  in 1890 in a [rotary compressor](#). He mixed it with  $\text{C}_2\text{H}_5\text{Br}$  to reduce its flammability. Edmund Copeland and Harry Edwards used iso-butane in 1920 in small refrigerators. It disappeared by 1930 when it was replaced by  $\text{CH}_3\text{Cl}$ . Dichloroethylene (Dielene or Dieline) was used by [Carrier](#) in centrifugal compressors in 1922-26.

### **1.3.1.1. Domestic refrigeration systems:**

The domestic refrigerator using natural ice (domestic ice box) was invented in 1803 and was used for almost 150 years without much alteration. The domestic ice box used to be made of wood with suitable insulation. Ice used to be kept at the top of the box, and low temperatures are produced in the box due to heat transfer from ice by natural convection. A drip pan is used to collect the water formed due to the melting of ice. The box has to be replenished with fresh ice once all the ice melts. Though the concept is quite simple, the domestic ice box suffered from several disadvantages. The user has to replenish the ice as

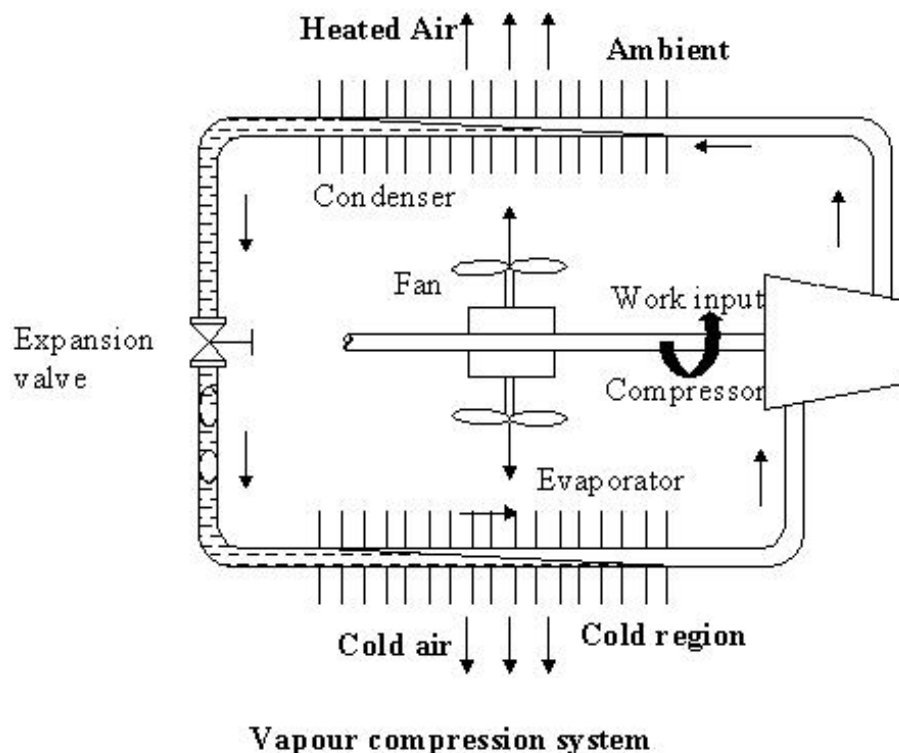
soon as it is consumed, and the lowest temperatures that could be produced inside the compartment are limited. In addition, it appears that warm winters caused severe shortage of natural ice in USA. Hence, efforts, starting from 1887 have been made to develop domestic refrigerators using mechanical systems. The initial domestic mechanical refrigerators were costly, not completely automatic and were not very reliable. However, the development of mechanical household refrigerators on a large scale was made possible by the development of small compressors, automatic refrigerant controls, better shaft seals, developments in electrical power systems and induction motors. General Electric Company introduced the first domestic refrigerator in 1911, followed by Frigidaire in 1915. Kelvinator launched the domestic mechanical refrigerator in 1918 in USA. In 1925, USA had about 25 million domestic refrigerators of which only 75000 were mechanical. However, the manufacture of domestic refrigerators grew very rapidly, and by 1949 about 7 million domestic refrigerators were produced annually. With the production volumes increasing the price fell sharply (the price was 600 dollars in 1920 and 155 dollars in 1940). The initial domestic refrigerators used mainly sulphur dioxide as refrigerant. Some units used methyl chloride and methylene chloride. These refrigerants were replaced by Freon-12 in 1930s. In the beginning these refrigerators were equipped with open type compressors driven by belt drive. General Electric Company introduced the first refrigerator with a hermetic compressor in 1926. Soon the open type compressors were completely replaced by the hermetic compressors. First refrigerators used water-cooled condensers, which were soon replaced by air cooled-condensers. Though the development of mechanical domestic refrigerators was very rapid in USA, it was still rarely used in other countries. In 1930 only rich families used domestic refrigerators in Europe. The domestic refrigerator based on absorption principle as proposed by Platen and Munters, was first made by Electrolux Company in 1931 in Sweden. In Japan the first mechanical domestic refrigerator was made in 1924. The first dual temperature (freezer-refrigerator) domestic refrigerator was introduced in 1939. The use of mechanical domestic refrigerators grew rapidly all over the world after the Second World War. Today, a domestic refrigerator has become an essential kitchen appliance not only in highly developed countries but also in countries such as India. Except very few almost all the present day domestic refrigerators are mechanical refrigerators that use a hermetic compressor and an air cooled condenser. The modern refrigerators use either HFC-134a (hydro-fluoro-carbon) or iso-butane as refrigerant.

### **1.3.1.2. Air conditioning systems:**

Refrigeration systems are also used for providing cooling and dehumidification in summer for personal comfort (air conditioning). The first air conditioning systems were used for industrial as well as comfort air conditioning. Eastman Kodak installed the first air conditioning system in 1891 in Rochester, New York for the storage of photographic films. An air conditioning system was installed in a printing press in 1902 and in a telephone exchange in Hamburg in 1904. Many systems were installed in tobacco and textile factories around 1900. The first domestic air conditioning system was installed in a house in Frankfurt in 1894. A private library in St Louis, USA was air conditioned in 1895, and a casino was air conditioned in Monte Carlo in 1901. Efforts have also been made to air condition passenger rail coaches using ice. The widespread development of air conditioning is attributed to the American scientist and industrialist Willis Carrier. Carrier studied the control of humidity in 1902 and designed a central air conditioning plant using air washer in 1904. Due to the pioneering efforts of Carrier and also due to simultaneous development of different components and controls, air conditioning quickly became very popular, especially after 1923. At present comfort air conditioning is widely used in residences, offices, commercial buildings, air ports, hospitals and in mobile applications such as rail coaches, automobiles,

aircrafts etc. Industrial air conditioning is largely responsible for the growth of modern electronic, pharmaceutical, chemical industries etc. Most of the present day air conditioning systems use either a vapour compression refrigeration system or a vapour absorption refrigeration system. The capacities vary from few kilowatts to megawatts.

Figure 1.3 shows the basic components of a vapour compression refrigeration system. As shown in the figure the basic system consists of an evaporator, compressor, condenser and an expansion valve. The refrigeration effect is obtained in the cold region as heat is extracted by the vaporization of refrigerant in the evaporator. The refrigerant vapour from the evaporator is compressed in the compressor to a high pressure at which its saturation temperature is greater than the ambient or any other heat sink. Hence when the high pressure, high temperature refrigerant flows through the condenser, condensation of the vapour into liquid takes place by heat rejection to the heat sink. To complete the cycle, the high pressure liquid is made to flow through an expansion valve. In the expansion valve the pressure and temperature of the refrigerant decrease. This low pressure and low temperature refrigerant vapour evaporates in the evaporator taking heat from the cold region. It should be observed that the system operates on a closed cycle. The system requires input in the form of mechanical work. It extracts heat from a cold space and rejects heat to a high temperature heat sink.



*Fig.1.3. Schematic of a basic vapour compression refrigeration system*

A refrigeration system can also be used as a heat pump, in which the useful output is the high temperature heat rejected at the condenser. Alternatively, a refrigeration system can be used for providing cooling in summer and heating in winter. Such systems have been built and are available now.

**Q.** Compared to natural refrigeration methods, artificial refrigeration methods are:

- a) Continuous
- b) Reliable
- c) Environment friendly
- d) Can work under almost all conditions

**Ans.** a), b) and d)

**Q.** In the evaporator of a vapour compression refrigeration system:

- a) A low temperature is maintained so that heat can flow from the external fluid
- b) Refrigeration effect is produced as the refrigerant liquid vaporizes
- c) A low pressure is maintained so that the compressor can run
- d) All of the above

**Ans.** a) and b)

**Q.** The function of a compressor in a vapour compression refrigeration system is to:

- a) To maintain the required low-side pressure in the evaporator
- b) To maintain the required high-side pressure in the condenser
- c) To circulate required amount of refrigerant through the system
- d) To safeguard the refrigeration system

**Ans.** a), b) and c)

**Q.** In a vapour compression refrigeration system, a condenser is primarily required so that:

- a) A high pressure can be maintained in the system
- b) The refrigerant evaporated in the evaporator can be recycled
- c) Performance of the system can be improved
- d) Low temperatures can be produced

**Ans.** b)

**Q.** The function of an expansion valve is to:

- a) Reduce the refrigerant pressure
- b) Maintain high and low side pressures
- c) Protect evaporator
- d) All of the above

**Ans.** b)

**Q.** In a domestic icebox type refrigerator, the ice block is kept at the top because:

- a) It is convenient to the user
- b) Disposal of water is easier
- c) Cold air can flow down due to buoyancy effect
- d) None of the above

**Ans.** c)

**Q.** An air conditioning system employs a refrigeration system to:

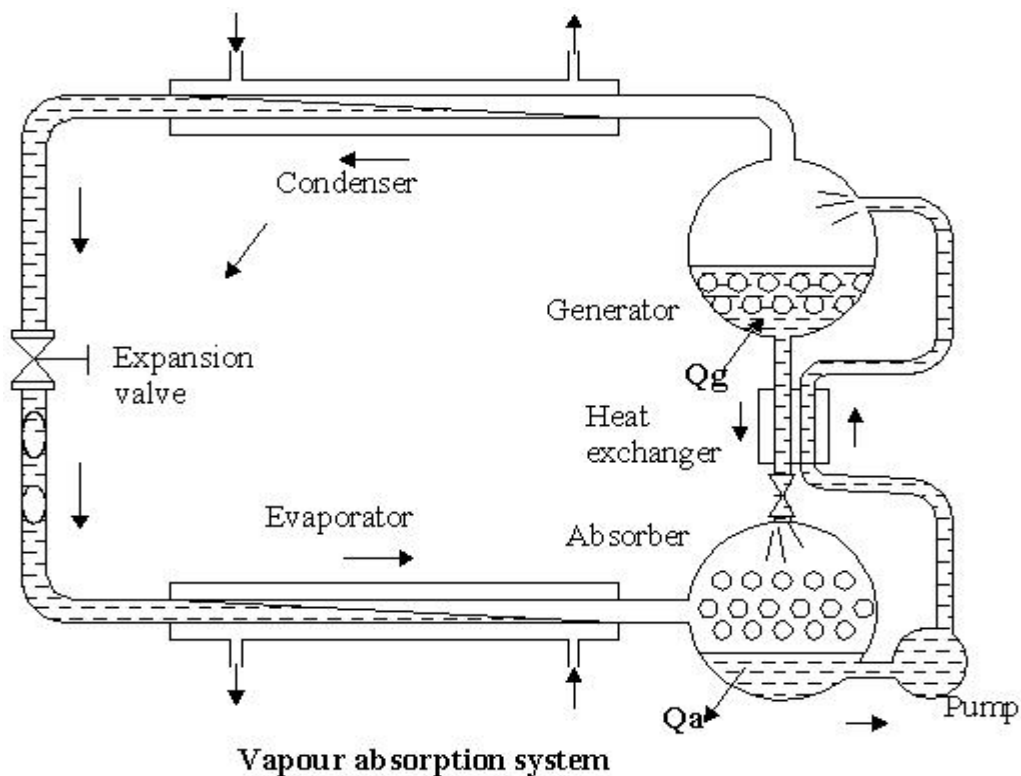
- a) Cool and dehumidify air supplied to the conditioned space
- b) To heat and humidify the air supplied to the conditioned space
- c) To circulate the air through the system
- d) To purify the supply air

**Ans.** a)

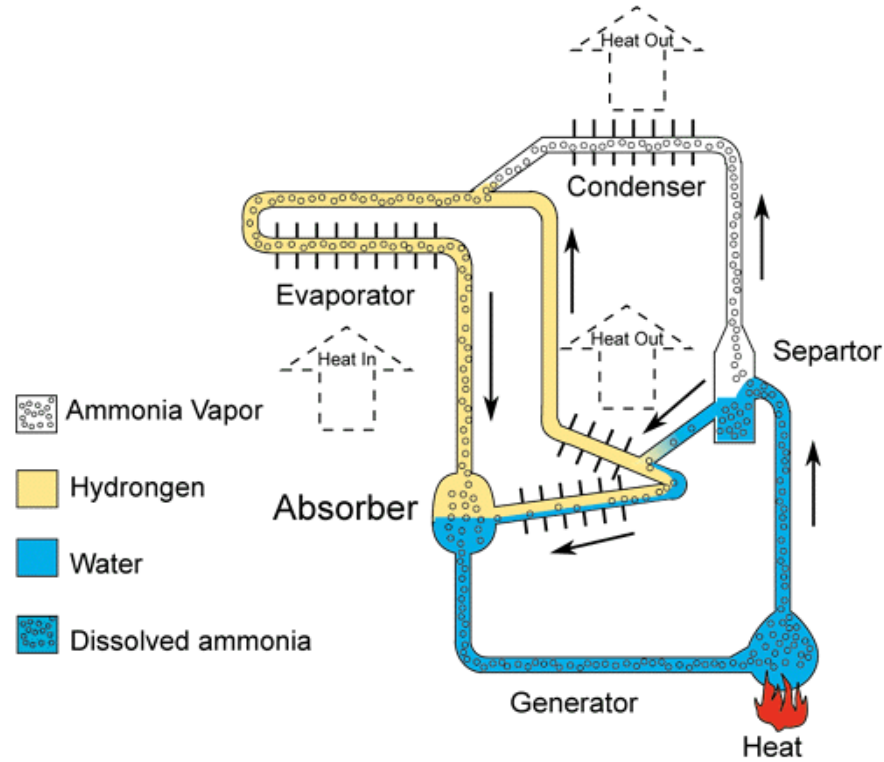


### 1.3.2. Vapour Absorption Refrigeration Systems:

[John Leslie](#) in 1810 kept  $H_2SO_4$  and water in two separate jars connected together.  $H_2SO_4$  has very high affinity for water. It absorbs water vapour and this becomes the principle of removing the evaporated water vapour requiring no compressor or pump.  $H_2SO_4$  is an absorbent in this system that has to be recycled by heating to get rid of the absorbed water vapour, for continuous operation. [Windhausen](#) in 1878 used this principle for absorption refrigeration system, which worked on  $H_2SO_4$ . [Ferdinand Carre](#) invented aqua-ammonia absorption system in 1860. Water is a strong absorbent of  $NH_3$ . If  $NH_3$  is kept in a vessel that is exposed to another vessel containing water, the strong absorption potential of water will cause evaporation of  $NH_3$  requiring no compressor to drive the vapours. A liquid pump is used to increase the pressure of strong solution. The strong solution is then heated in a generator and passed through a rectification column to separate the water from ammonia. The ammonia vapour is then condensed and recycled. The pump power is negligible hence; the system runs virtually on [low- grade energy](#) used for heating the strong solution to separate the water from ammonia. These systems were initially run on steam. Later on oil and natural gas based systems were introduced. Figure 1.4 shows the essential components of a vapour absorption refrigeration system. In 1922, Balzar von Platen and Carl Munters, two students at Royal Institute of Technology, Stockholm invented a three fluid system that did not require a pump. A heating based bubble pump was used for circulation of strong and weak solutions and hydrogen was used as a non-condensable gas to reduce the partial pressure of  $NH_3$  in the evaporator. Geppert in 1899 gave this original idea but he was not successful since he was using air as non-condensable gas. The Platen-Munters refrigeration systems are still widely used in certain niche applications such as hotel rooms etc. Figure 1.5 shows the schematic of the triple fluid vapour absorption refrigeration system.



*Fig.1.4. Essential components of a vapour absorption refrigeration system*



**Fig.1.5.** Schematic of a triple fluid vapour absorption refrigeration system

Another variation of vapour absorption system is the one based on Lithium Bromide (LiBr)-water. This system is used for chilled water air-conditioning system. This is a descendent of Windhausen’s machine with LiBr replacing  $H_2SO_4$ . In this system LiBr is the absorbent and water is the refrigerant. This system works at vacuum pressures. The condenser and the generator are housed in one cylindrical vessel and the evaporator and the absorber are housed in second vessel. This also runs on [low-grade energy](#) requiring a boiler or process steam.

### 1.3.3. Solar energy based refrigeration systems:

Attempts have been made to run vapour absorption systems by solar energy with concentrating and flat plate solar collectors. Several small solar absorption refrigeration systems have been made around 1950s in several countries. Professor G.O.G. L f of America is one of the pioneers in the area of solar refrigeration using flat plate collectors. A solar refrigeration system that could produce 250 kg of ice per day was installed in Tashkent, USSR in 1953. This system used a parabolic mirror of  $10\text{ m}^2$  area for concentrating the solar radiation. F. Trombe installed an absorption machine with a cylindro-parabolic mirror of  $20\text{ m}^2$  at Montlouis, France, which produced 100 kg of ice per day.

Serious consideration to solar refrigeration systems was given since 1965, due to the scarcity of fossil fuel based energy sources. LiBr-water based systems have been developed for air conditioning purposes. The first solar air conditioning system was installed in an experimental solar house in University of Queensland, Australia in 1966. After this several systems based on solar energy were built in many parts of the world including India. In 1976, there were about 500 solar absorption systems in USA alone. Almost all these were based on LiBr-water as these systems do not require very high heating temperatures. These systems were mainly used for space air conditioning.

Intermittent absorption systems based on solar energy have also been built and operated successfully. In these systems, the cooling effect is obtained during the nighttime, while the system gets “charged” during the day using solar energy. Though the efficiency of these systems is rather poor requiring solar collector area, they may find applications in

remote and rural areas where space is not a constraint. In addition, these systems are environment friendly as they use eco-friendly refrigerants and run on clean and renewable solar energy.

Solar adsorption refrigeration system with ammoniacates, sodium thiocyanate, activated charcoal, zeolite as adsorbents and ammonia, alcohols or fluorocarbons as refrigerants have also been in use since 1950s. These systems also do not require a compressor. The refrigerant vapour is driven by the adsorption potential of the adsorbent stored in an adsorbent bed. This bed is connected to an evaporator/condenser, which consists of the pure refrigerant. In intermittent adsorption systems, during the night the refrigerant evaporates and is adsorbed in activated charcoal or zeolite providing cooling effect. During daytime the adsorbent bed absorbs solar radiation and drives off the refrigerant stored in the bed. This refrigerant vapour condenses in the condenser and stored in a reservoir for nighttime use. Thus this simple system consists of an adsorbent bed and a heat exchanger, which acts as a condenser during the nighttime and, as an evaporator during the night. Pairs of such reactors can be used for obtaining a continuous cooling

**Q.** Compared to the compression systems, vapour absorption refrigeration systems:

- a) Are environment friendly
- b) Use low-grade thermal energy for operation
- c) Cannot be used for large capacity refrigeration systems
- d) Cannot be used for small capacity refrigeration systems

**Ans.** a) and b)

**Q.** In absorption refrigeration systems, the compressor of vapour compression systems is replaced by:

- a) Absorber
- b) Generator
- c) Pump
- d) All of the above

**Ans.** d)

**Q.** In a triple fluid vapour absorption refrigeration system, the hydrogen gas is used to:

- a) Improve system performance
- b) Reduce the partial pressure of refrigerant in evaporator
- c) Circulate the refrigerant
- d) Provide a vapour seal

**Ans.** b)

**Q.** Solar energy based refrigeration systems are developed to:

- a) Reduce fossil fuel consumption
- b) Provide refrigeration in remote areas
- c) Produce extremely low temperatures
- d) Eliminate compressors

**Ans.** a) and b)

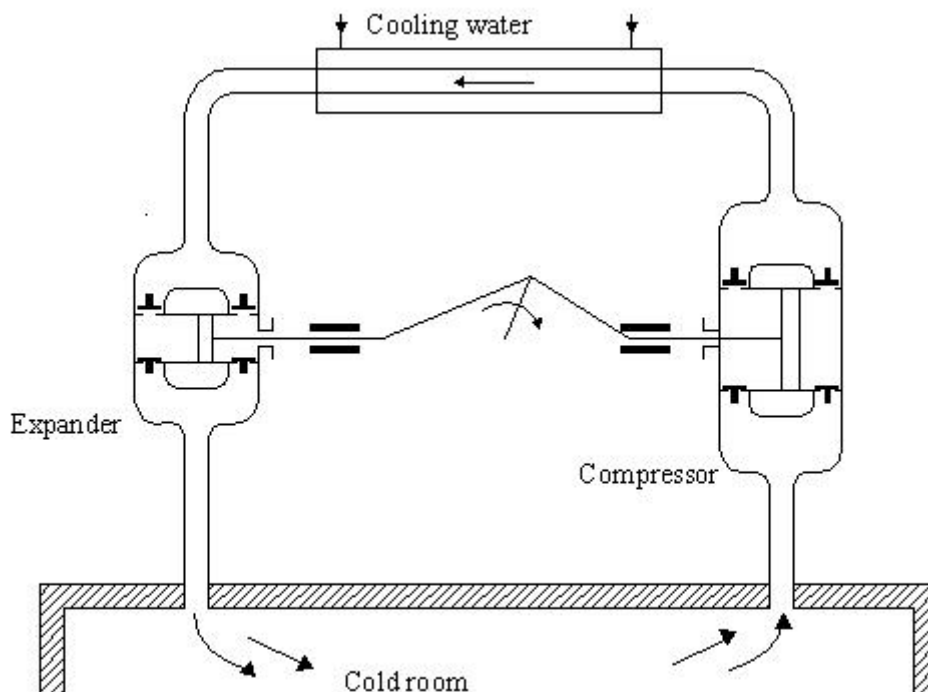
**Q.** Solar energy based refrigeration systems:

- a) Cannot be used for large capacity systems
- b) Cannot be made continuous
- c) Are not environment friendly
- d) None of the above

**Ans.** d)

### 1.3.4. Gas Cycle Refrigeration:

If air at high pressure expands and does work (say moves a piston or rotates a turbine), its temperature will decrease. This fact is known to man as early as the 18<sup>th</sup> century. Dalton and Gay Lusaac studied this in 1807. Sadi Carnot mentioned this as a well-known phenomenon in 1824. However, Dr. John Gorrie a physician in Florida developed one such machine in 1844 to produce ice for the relief of his patients suffering from fever. This machine used compressed air at 2 atm. pressure and produced brine at a temperature of  $-7^{\circ}\text{C}$ , which was then used to produce ice. Alexander Carnegie Kirk in 1862 made an air cycle cooling machine. This system used steam engine to run its compressor. Using a compression ratio of 6 to 8, Kirk could produce temperatures as low as  $-40^{\circ}\text{C}$ . Paul Gifford in 1875 perfected the open type of machine. This machine was further improved by T B Lightfoot, A Haslam, Henry Bell and James Coleman. This was the main method of marine refrigeration for quite some time. Frank Allen in New York developed a closed cycle machine employing high pressures to reduce the volume flow rates. This was named dense air machine. These days air cycle refrigeration is used only in aircrafts whose turbo compressor can handle large volume flow rates. Figure 1.6 shows the schematic of an open type air cycle refrigeration system. The basic system shown here consists of a compressor, an expander and a heat exchanger. Air from the cold room is compressed in the compressor. The hot and high pressure air rejects heat to the heat sink (cooling water) in the heat exchanger. The warm but high pressure air expands in the expander. The cold air after expansion is sent to the cold room for providing cooling. The work of expansion partly compensates the work of compression; hence both the expander and the compressor are mounted on a common shaft.

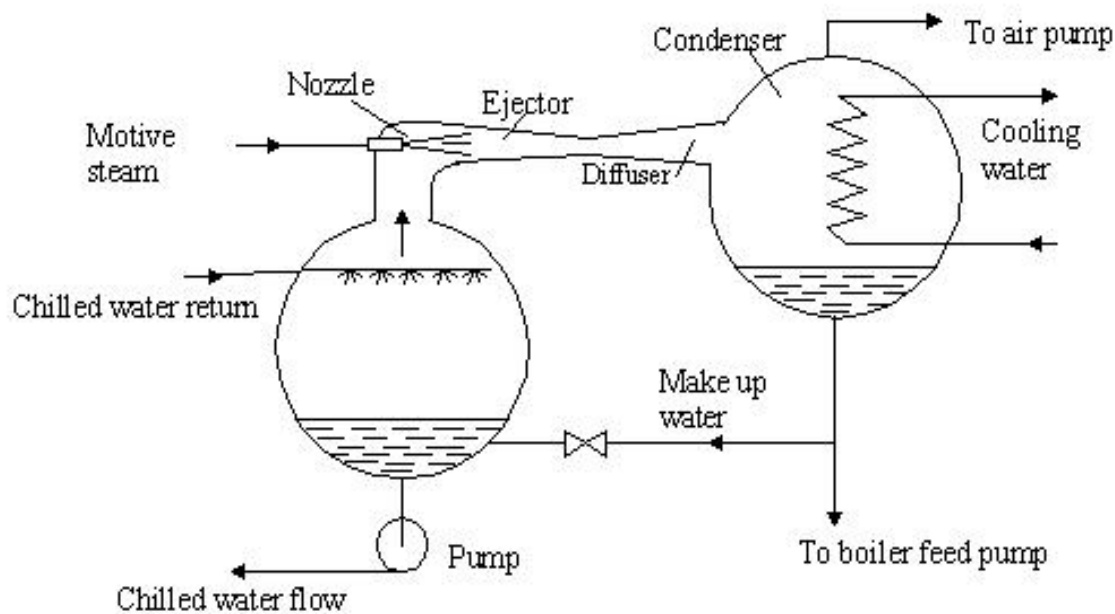


**Schematic diagram of the cold air system**

*Fig.1.6. Schematic of a basic, open type air cycle refrigeration system*

### 1.3.5. Steam Jet Refrigeration System:

If water is sprayed into a chamber where a low pressure is maintained, a part of the water will evaporate. The enthalpy of evaporation will cool the remaining water to its saturation temperature at the pressure in the chamber. Obviously lower temperature will require lower pressure. Water freezes at  $0^{\circ}\text{C}$  hence temperature lower than  $4^{\circ}\text{C}$  cannot be obtained with water. In this system, high velocity steam is used to entrain the evaporating water vapour. High-pressure motive steam passes through either convergent or convergent-divergent nozzle where it acquires either sonic or supersonic velocity and low pressure of the order of 0.009 kPa corresponding to an evaporator temperature of  $4^{\circ}\text{C}$ . The high momentum of motive steam entrains or carries along with it the water vapour evaporating from the flash chamber. Because of its high velocity it moves the vapours against the pressure gradient up to the condenser where the pressure is 5.6-7.4 kPa corresponding to condenser temperature of  $35\text{-}45^{\circ}\text{C}$ . The motive vapour and the evaporated vapour both are condensed and recycled. This system is known as steam jet refrigeration system. Figure 1.7 shows a schematic of the system. It can be seen that this system requires a good vacuum to be maintained. Sometimes, booster ejector is used for this purpose. This system is driven by [low- grade energy](#) that is process steam in chemical plants or a boiler.



**Steam jet refrigeration system**

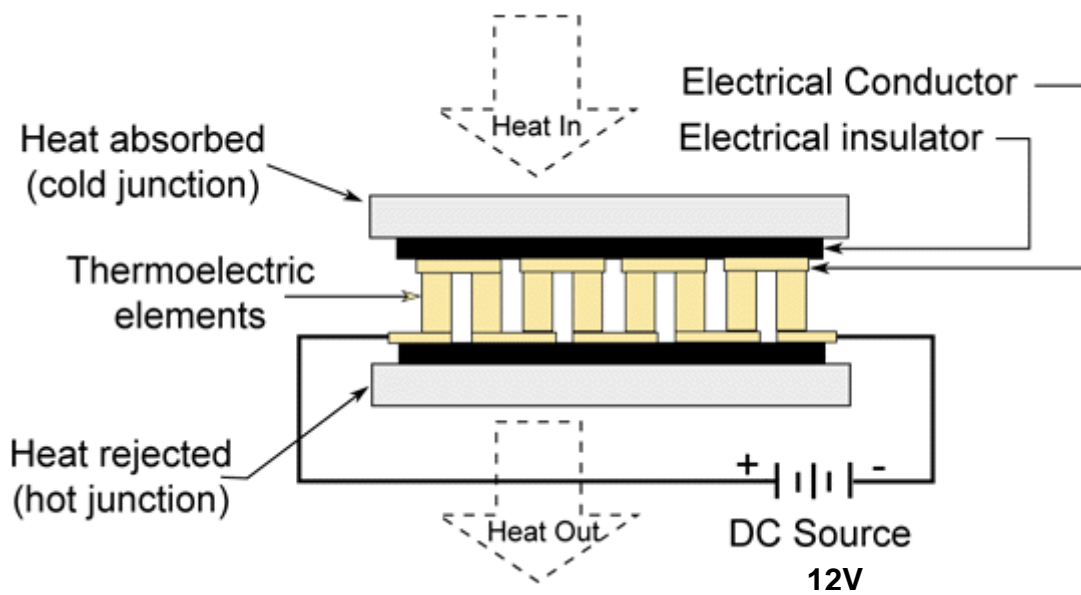
*Fig.1.7. Schematic of a steam jet refrigeration system*

In 1838, the Frenchman Pelletan was granted a patent for the compression of steam by means of a jet of motive steam. Around 1900, the Englishman Charles Parsons studied the possibility of reduction of pressure by an entrainment effect from a steam jet. However, the credit for constructing the steam jet refrigeration system goes to the French engineer, Maurice Leblanc who developed the system in 1907-08. In this system, ejectors were used to produce a high velocity steam jet ( $\approx 1200$  m/s). Based on Leblanc's design the first commercial system was made by Westinghouse in 1909 in Paris. Even though the efficiency of the steam jet refrigeration system was low, it was still attractive as water is harmless and the system can run using exhaust steam from a steam engine. From 1910 onwards, steam jet refrigeration

systems were used mainly in breweries, chemical factories, warships etc. In 1926, the French engineer Follain improved the machine by introducing multiple stages of vaporization and condensation of the suction steam. Between 1928-1930, there was much interest in this type of systems in USA. In USA they were mainly used for air conditioning of factories, cinema theatres, ships and even railway wagons. Several companies such as Westinghouse, Ingersoll Rand and Carrier started commercial production of these systems from 1930. However, gradually these systems were replaced by more efficient vapour absorption systems using LiBr-water. Still, some east European countries such as Czechoslovakia and Russia manufactured these systems as late as 1960s. The ejector principle can also be used to provide refrigeration using fluids other than water, i.e., refrigerants such as CFC-11, CFC-21, CFC-22, CFC-113, CFC-114 etc. The credit for first developing these closed vapour jet refrigeration systems goes to the Russian engineer, I.S. Badylkes around 1955. Using refrigerants other than water, it is possible to achieve temperatures as low as  $-100^{\circ}\text{C}$  with a single stage of compression. The advantages cited for this type of systems are simplicity and robustness, while difficult design and economics are its chief disadvantages.

### **1.3.6. Thermoelectric Refrigeration Systems:**

In 1821 the German physicist T.J. Seebeck reported that when two junctions of dissimilar metals are kept at two different temperatures, an electro motive force (emf) is developed, resulting in flow of electric current. The emf produced is found to be proportional to temperature difference. In 1834, a Frenchmen, J. Peltier observed the reverse effect, i.e., cooling and heating of two junctions of dissimilar materials when direct current is passed through them, the heat transfer rate being proportional to the current. In 1838, H.F.E. Lenz froze a drop of water by the Peltier effect using antimony and bismuth (it was later found that Lenz could freeze water as the materials used were not pure metals but had some impurities in them). In 1857, William Thomson (Lord Kelvin) proved by thermodynamic analysis that Seebeck effect and Peltier effect are related and he discovered another effect called Thomson effect after his name. According to this when current flows through a conductor of a thermocouple that has an initial temperature gradient in it, then heat transfer rate per unit length is proportional to the product of current and the temperature. As the current flow through thermoelectric material it gets heated due to its electrical resistance. This is called the Joulean effect, further, conduction heat transfer from the hot junction to the cold junction transfers heat. Both these heat transfer rates have to be compensated by the Peltier Effect for some useful cooling to be produced. For a long time, thermoelectric cooling based on the Peltier effect remained a laboratory curiosity as the temperature difference that could be obtained using pure metals was too small to be of any practical use. Insulating materials give poor thermoelectric performance because of their small electrical conductivity while metals are not good because of their large thermal conductivity. However, with the discovery of semiconductor materials in 1949-50, the available temperature drop could be increased considerably, giving rise to commercialization of thermoelectric refrigeration systems. Figure 1.8 shows the schematic of the thermoelectric refrigeration system based on semiconductor materials. The Russian scientist, A. F. Ioffe is one of the pioneers in the area of thermoelectric refrigeration systems using semiconductors. Several domestic refrigerators based on thermoelectric effect were made in USSR as early as 1949. However, since 1960s these systems are used mainly used for storing medicines, vaccines etc and in electronic cooling. Development also took place in many other countries. In USA domestic refrigerators, air conditioners, water coolers, air conditioned diving suits etc. were made



*Fig. 1.8. Schematic of a thermoelectric refrigeration system*

using these effects. System capacities were typically small due to poor efficiency. However some large refrigeration capacity systems such as a 3000 kcal/h air conditioner and a 6 tonne capacity cold storage were also developed. By using multistaging temperatures as low as  $-145^{\circ}\text{C}$  were obtained. These systems due to their limited performance (limited by the materials) are now used only in certain niche applications such as electronic cooling, mobile coolers etc. Efforts have also been made to club thermoelectric systems with photovoltaic cells with a view to develop solar thermoelectric refrigerators.

### 1.3.7. Vortex tube systems:

In 1931, the French engineer Georges Ranque (1898-1973) discovered an interesting phenomenon, which is called “Ranque effect” or “vortex effect”. The tangential injection of air into a cylindrical tube induces to quote his words “ a giratory expansion with simultaneous production of an escape of hot air and an escape of cold air”. Ranque was granted a French patent in 1928 and a US patent in 1934 for this effect. However, the discovery was neglected until after the second world war, when in 1945, Rudolph Hilsch, a German physicist, studied this effect and published a widely read scientific paper on this device. Thus, the vortex tube has also been known as the “*Ranque-Hilsch Tube*”. Though the efficiency of this system is quite low, it is very interesting due to its mechanical simplicity and instant cooling. It is convenient where there is a supply of compressed air. The present day vortex tube uses compressed air as a power source, it has no moving parts, and produces hot air from one end and cold air from the other. The volume and temperature of these two airstreams are adjustable with a valve built into the hot air exhaust. Temperatures as low as  $-46^{\circ}\text{C}$  and as high as  $127^{\circ}\text{C}$  are possible. Compressed air is supplied to the vortex tube and passes through nozzles that are tangential to an internal counter bore. These nozzles set the air in a vortex motion. This spinning stream of air turns  $90^{\circ}$  and passes down the hot tube in the form of a spinning shell, similar to a tornado. A valve at one end of the tube allows some of the warmed air to escape. What does not escape, heads back down the tube as a second vortex inside the low-pressure area of the larger vortex. This inner vortex loses heat and exhausts through the other end as cold air. Currently vortex tube is used for spot cooling of machine parts, in electronic cooling and also in cooling jackets for miners, firemen etc.

**Q.** In an air cycle refrigeration system, low temperatures are produced due to:

- a) Evaporation of liquid air
- b) Throttling of air
- c) Expansion of air in turbine
- d) None of the above

**Ans.** c)

**Q.** Air cycle refrigeration systems are most commonly used in:

- a) Domestic refrigerators
- b) Aircraft air conditioning systems
- c) Cold storages
- d) Car air conditioning systems

**Ans.** b)

**Q.** The required input to the steam jet refrigeration systems is in the form of:

- a) Mechanical energy
- b) Thermal energy
- c) High pressure, motive steam
- d) Both mechanical and thermal energy

**Ans.** c)

**Q.** A nozzle is used in steam jet refrigeration systems to:

- a) To convert the high pressure motive steam into high velocity steam
- b) To reduce energy consumption
- c) To improve safety aspects
- d) All of the above

**Ans.** a)

**Q.** The materials used in thermoelectric refrigeration systems should have:

- a) High electrical and thermal conductivity
- b) High electrical conductivity and low thermal conductivity
- c) Low electrical conductivity and high thermal conductivity
- d) Low electrical and thermal conductivity

**Ans.** b)

**Q.** A thermoelectric refrigeration systems requires:

- a) A high voltage AC (alternating current) input
- b) A low voltage AC input
- c) A high voltage DC (direct current) input
- d) A low voltage DC input

**Ans.** d).



### 1.3.8. Summary:

In this lecture the student is introduced to different methods of refrigeration, both natural and artificial. Then a brief history of artificial refrigeration techniques is presented with a mention of the pioneers in this field and important events. The working principles of these systems are also described briefly. In subsequent chapters the most important of these refrigeration systems will be discussed in detail.

#### Questions:

**Q.** Explain why ice making using nocturnal cooling is difficult on nights when the sky is cloudy?

**Ans.** In order to make ice from water, water has to be first sensibly cooled from its initial temperature to its freezing point ( $0^{\circ}\text{C}$ ) and then latent heat has to be transferred at  $0^{\circ}\text{C}$ . This requires a heat sink that is at a temperature lower than  $0^{\circ}\text{C}$ . Ice making using nocturnal cooling relies on radiative heat transfer from the water to the sky (which is at about  $-55^{\circ}\text{C}$ ) that acts as a heat sink. When the sky is cloudy, the clouds reflect most of the radiation back to earth and the effective surface temperature of clouds is also much higher. As a result, radiative heat transfer from the water becomes very small, making the ice formation difficult.

**Q.** When you add sufficient amount of glucose to a glass of water, the water becomes cold. Is it an example of refrigeration, if it is, can this method be used for devising a refrigeration system?

**Ans.** Yes, this is an example of refrigeration as the temperature of glucose solution is lower than the surroundings. However, this method is not viable, as the production of refrigeration continuously requires an infinite amount of water and glucose or continuous recovery of glucose from water.

**Q.** To what do you attribute the rapid growth of refrigeration technology over the last century?

**Ans.** The rapid growth of refrigeration technology over the last century can be attributed to several reasons, some of them are:

- i. Growing global population leading to growing demand for food, hence, demand for better food processing and food preservation methods. Refrigeration is required for both food processing and food preservation (Food Chain)
- ii. Growing demand for refrigeration in almost all industries
- iii. Growing demand for comfortable conditions (air conditioned) at residences, workplaces etc.
- iv. Rapid growth of technologies required for manufacturing various refrigeration components
- v. Availability of electricity, and
- vi. Growing living standards

# Lesson 2

## History Of Refrigeration – Development Of Refrigerants And Compressors

The objectives of the present lesson are to introduce the student to the history of refrigeration in terms of:

1. Refrigerant development (*Section 2.2*):

- i. Early refrigerants (*Section 2.2.1*)
- ii. Synthetic fluorocarbon based refrigerants (*Section 2.2.2*)
- iii. Non-ozone depleting refrigerants (*Section 2.2.3*)

2. Compressor development (*Section 2.3*):

- i. Low-speed steam engine driven compressors (*Section 2.3.1*)
- ii. High-speed electric motor driven compressors (*Section 2.3.1*)
- iii. Rotary vane and rolling piston compressors (*Section 2.3.2*)
- iv. Screw compressors (*Section 2.3.2*)
- v. Scroll compressors (*Section 2.3.2*)
- vi. Centrifugal compressors (*Section 2.3.3*)

At the end of the lesson the student should be able to:

- i. State the importance of refrigerant selection
- ii. List various refrigerants used before the invention of CFCs
- iii. List various CFC refrigerants and their impact on refrigeration
- iv. State the environmental issues related to the use of CFCs
- v. State the refrigerant development after Montreal protocol
- vi. List important compressor types
- vii. List important landmarks in the development of compressors

## 2.1. Introduction:

The development of refrigeration and air conditioning industry depended to a large extent on the development of refrigerants to suit various applications and the development of various system components. At present the industry is dominated by the vapour compression refrigeration systems, even though the vapour absorption systems have also been developed commercially. The success of vapour compression refrigeration systems owes a lot to the development of suitable refrigerants and compressors. The theoretical thermodynamic efficiency of a vapour compression system depends mainly on the operating temperatures. However, important practical issues such as the system design, size, initial and operating costs, safety, reliability, and serviceability etc. depend very much on the type of refrigerant and compressor selected for a given application. This lesson presents a brief history of refrigerants and compressors. The emphasis here is mainly on vapour compression refrigeration systems, as these are the most commonly used systems, and also refrigerants and compressors play a critical role here. The other popular type of refrigeration system, namely the vapour absorption type has seen fewer changes in terms of refrigerant development, and relatively less number of problems exist in these systems as far as the refrigerants are concerned.

## 2.2. Refrigerant development – a brief history

In general a refrigerant may be defined as “any body or substance that acts as a cooling medium by extracting heat from another body or substance”. Under this general definition, many bodies or substances may be called as refrigerants, e.g. ice, cold water, cold air etc. In closed cycle vapour compression, absorption systems, air cycle refrigeration systems the refrigerant is a working fluid that undergoes cyclic changes. In a thermoelectric system the current carrying electrons may be treated as a refrigerant. However, normally by refrigerants we mean the working fluids that undergo condensation and evaporation as in compression and absorption systems. The history that we are talking about essentially refers to these substances. Since these substances have to evaporate and condense at required temperatures (which may broadly lie in the range of  $-100^{\circ}\text{C}$  to  $+100^{\circ}\text{C}$ ) at reasonable pressures, they have to be essentially volatile. Hence, the development of refrigerants started with the search for suitable, volatile substances. Historically the development of these refrigerants can be divided into three distinct phases, namely:

- i. Refrigerants prior to the development of CFCs
- ii. The synthetic fluorocarbon (FC) based refrigerants
- iii. Refrigerants in the aftermath of stratospheric ozone layer depletion

### 2.2.1. Refrigerants prior to the development of CFCs

Water is one of the earliest substances to be used as a refrigerant, albeit not in a closed system. Production of cold by evaporation of water dates back to 3000 B.C. Archaeological findings show pictures of Egyptian slaves waving fans in front of earthenware jars to accelerate the evaporation of water from the porous surfaces of the pots, thereby producing cold water. Of course, the use of “punkahs” for body cooling in hot summer is very well known in countries like India. Production of ice by nocturnal cooling is also well known. People also had some knowledge of producing sub-zero temperatures by the use of “refrigerant mixtures”. It is believed that as early as 4<sup>th</sup> Century AD people in India were using mixtures of salts (sodium nitrate, sodium chloride etc) and water to produce temperatures as low as  $-20^{\circ}\text{C}$ . However, these natural refrigeration systems working with water have many limitations and hence were confined to a small number of applications.

*Water* was the first refrigerant to be used in a continuous refrigeration system by William Cullen (1710-1790) in 1755. William Cullen is also the first man to have scientifically observed the production of low temperatures by evaporation of *ethyl ether* in 1748. Oliver Evans (1755-1819) proposed the use of a volatile fluid in a closed cycle to produce ice from water. He described a practical system that uses *ethyl ether* as the refrigerant. As already mentioned the credit for building the first vapour compression refrigeration system goes to Jakob Perkins (1766-1849). Perkins used *sulphuric (ethyl) ether* obtained from India rubber as refrigerant. Early commercial refrigerating machines developed by James Harrison (1816-1893) also used *ethyl ether* as refrigerant. Alexander Twining (1801-1884) also developed refrigerating machines using *ethyl ether*. After these developments, *ethyl ether* was used as refrigerant for several years for ice making, in breweries etc. Ether machines were gradually replaced by ammonia and carbon dioxide based machines, even though they were used for a longer time in tropical countries such as India.

Ethyl ether appeared to be a good refrigerant in the beginning, as it was easier to handle it since it exists as a liquid at ordinary temperatures and atmospheric pressure. Ethyl ether has a normal boiling point (NBP) of  $34.5^{\circ}\text{C}$ , this indicates that in order to obtain low temperatures, the evaporator pressure must be lower than one atmosphere, i.e., operation in vacuum. Operation of a system in vacuum may lead to the danger of outside air leaking into the system resulting in the formation of a potentially explosive mixture. On the other hand a relatively high normal boiling point indicates lower pressures in the condenser, or for a given pressure the condenser can be operated at higher condensing temperatures. This is the reason behind the longer use of ether in tropical countries with high ambient temperatures. Eventually due to the high NBP, toxicity and flammability problems ethyl ether was replaced by other refrigerants. Charles Tellier (1828-1913) introduced *dimethyl ether* (NBP =  $23.6^{\circ}\text{C}$ ) in 1864. However, this refrigerant did not become popular, as it is also toxic and inflammable.

In 1866, the American T.S.C. Lowe (1832-1913) introduced *carbon dioxide* compressor. However, it enjoyed commercial success only in 1880s due largely to the efforts of German scientists Franz Windhausen (1829-1904) and Carl von Linde (1842-1934). Carbon dioxide has excellent thermodynamic and thermophysical properties, however, it has a low critical temperature ( $31.7^{\circ}\text{C}$ ) and very high operating pressures. Since it is non-flammable and non-toxic it found wide applications principally for marine refrigeration. It was also used for refrigeration applications on land. Carbon dioxide was used successfully for about sixty years however, it was completely replaced by CFCs. It is ironic to note that ever since the problem of ozone layer depletion was found, carbon dioxide is steadily making a comeback by replacing the synthetic CFCs/HFCs/HFOs etc.

One of the landmark events in the history of refrigerants is the introduction of *ammonia*. The American David Boyle (1837-1891) was granted the first patent for ammonia compressor in 1872. He made the first single acting vertical compressor in 1873. However, the credit for successfully commercializing ammonia systems goes to Carl von Linde (1842-1934) of Germany, who introduced these compressors in Munich in 1876. Linde is credited with perfecting the ammonia refrigeration technology and owing to his pioneering efforts; ammonia has become one of the most important refrigerants to be developed. Ammonia has a NBP of  $33.3^{\circ}\text{C}$ , hence, the operating pressures are much higher than atmospheric. Ammonia has excellent thermodynamic and thermophysical properties. It is easily available and inexpensive. However, ammonia is toxic and has a strong smell and slight flammability. In addition, it is not compatible with some of the common materials of construction such as copper. Though these are considered to be some of its disadvantages, ammonia has stood the test of time and the onslaught of CFCs due to its excellent properties. At present ammonia is used in large refrigeration systems (both vapour compression and vapour absorption) and also in small absorption refrigerators (triple fluid vapour absorption).

In 1874, Raoul Pictet (1846-1929) introduced *sulphur dioxide* (NBP=  $10.0^{\circ}\text{C}$ ). Sulphur dioxide was an important refrigerant and was widely used in small refrigeration systems such as domestic refrigerators due to its small refrigerating effect. Sulphur dioxide has the advantage of being an auto-lubricant. In addition it is not only non-flammable, but actually acts as a flame extinguisher. However, in the presence of water vapour it produces sulphuric acid, which is highly corrosive. The problem of corrosion was overcome by an airtight sealed compressor (both motor and compressor are mounted in the same outer

casing). However, after about sixty years of use in appliances such as domestic refrigerators, sulphur dioxide was replaced by CFCs.

In addition to the above, other fluids such as methyl chloride, ethyl chloride, iso-butane, propane, ethyl alcohol, methyl and ethyl amines, carbon tetra chloride, methylene chloride, gasoline etc. were tried but discarded due to one reason or other.

### 2.2.2. *The synthetic CFCs/HCFCs:*

Almost all the refrigerants used in the early stages of refrigeration suffered from one problem or other. Most of these problems were linked to safety issues such as toxicity, flammability, high operating pressures etc. As a result large-scale commercialization of refrigeration systems was hampered. Hence it was felt that “refrigeration industry needs a new refrigerant if they expect to get anywhere”. The task of finding a “safe” refrigerant was taken up by the American Thomas Midgley, Jr., in 1928. Midgley was already famous for the invention of tetra ethyl lead, an important anti-knock agent for petrol engines. Midgley along with his associates Albert L. Henne and Robert R. McNary at the Frigidaire Laboratories (Dayton, Ohio, USA) began a systematic study of the periodic table. From the periodic table they quickly eliminated all those substances yielding insufficient volatility. They then eliminated those elements resulting in unstable and toxic gases as well as the inert gases, based on their very low boiling points. They were finally left with eight elements: carbon, nitrogen, oxygen, sulphur, hydrogen, fluorine, chlorine and bromine. These [eight elements](#) clustered at an intersecting row and column of the periodic table, with fluorine at the intersection. Midgley and his colleagues then made three interesting observations:

- i. Flammability decreases from left to right for the eight elements
- ii. Toxicity generally decreases from the heavy elements at the bottom to the lighter elements at the top
- iii. Every known refrigerant at that time was made from the combination of those eight “Midgley” elements.

A look at the refrigerants discussed above shows that all of them are made up of seven out of the eight elements identified by Midgley (fluorine was not used till then). Other researchers have repeated Midgley’s search with more modern search methods and databases, but arrived at the same conclusions (almost all the currently used refrigerants are made up of Midgley elements, only exception is Iodine, studies are being carried out on refrigerants containing iodine in addition to some of the Midgley elements). Based on their study, Midgley and his colleagues have developed a whole range of new refrigerants, which are obtained by partial replacement of hydrogen atoms in hydrocarbons by fluorine and chlorine. They have shown how fluorination and chlorination of hydrocarbons can be varied to obtain desired boiling points (volatility) and also how properties such as toxicity, flammability are influenced by the composition. The first commercial refrigerant to come out of Midgley’s study is [Freon-12](#) in 1931. Freon-12 with a chemical formula  $\text{CCl}_2\text{F}_2$ , is obtained by replacing the four atoms of hydrogen in methane ( $\text{CH}_4$ ) by two atoms of chlorine and two atoms of fluorine. Freon-12 has a normal boiling point of  $29.8^\circ\text{C}$ , and is one of the most famous and popular synthetic refrigerants. It was exclusively used in small domestic refrigerators, air conditioners, water coolers etc for almost sixty years. Freon-11 ( $\text{CCl}_3\text{F}$ ) used in large centrifugal air conditioning systems was introduced in 1932. This is followed by Freon-22 ( $\text{CHClF}_2$ ) and a whole series of synthetic refrigerants to suit a wide variety of applications.

Due to the emergence of a large number of refrigerants in addition to the existence of the older refrigerants, it has become essential to work out a numbering system for refrigerants. Thus all refrigerants were indicated with 'R' followed by a unique number (thus Freon-12 is changed to R12 etc). The numbering of refrigerants was done based on certain guidelines. For all synthetic refrigerants the number (e.g. 11, 12, 22) denotes the chemical composition. The number of all inorganic refrigerants begins with '7' followed by their molecular weight. Thus R-717 denotes ammonia (ammonia is inorganic and its molecular weight is 17), R-718 denotes water etc.. [Refrigerant mixtures](#) begin with the number 4 (zeotropic) or 5 (azeotropic), e.g. R-500, R-502 etc.

The introduction of CFCs and related compounds has revolutionized the field of refrigeration and air conditioning. Most of the problems associated with early refrigerants such as toxicity, flammability, and material incompatibility were eliminated completely. Also, Freons are highly stable compounds. In addition, by cleverly manipulating the composition a whole range of refrigerants best suited for a particular application could be obtained. In addition to all this, a vigorous promotion of these refrigerants as "wonder gases" and "ideal refrigerants" saw rapid growth of Freons and equally rapid exit of conventional refrigerants such as carbon dioxide, sulphur dioxide etc. Only ammonia among the older refrigerants survived the Freon magic. The Freons enjoyed complete domination for about fifty years, until the Ozone Layer Depletion issue was raised by Rowland and Molina in 1974. Rowland and Molina in their now famous theory argued that the highly stable chlorofluorocarbons cause the [depletion of stratospheric ozone layer](#). Subsequent studies and observations confirmed Rowland and Molina theory on stratospheric ozone depletion by chlorine containing CFCs. In view of the seriousness of the problem on global scale, several countries have agreed to ban the harmful Ozone Depleting Substances, ODS (CFCs and others) in a phase-wise manner under [Montreal Protocol](#). Subsequently almost all countries of the world have agreed to the plan of CFC phase-out. In addition to the ozone layer depletion, the CFCs and related substances were also found to contribute significantly to the problem of "global warming". This once again brought the scientists back to the search for "safe" refrigerants. The "safety" now refers to not only the immediate personal safety issues such as flammability, toxicity etc., but also the long-term environmental issues such as ozone layer depletion and global warming.

### *2.2.3. Refrigerants in the aftermath of Ozone Layer Depletion:*

The most important requirement for refrigerants in the aftermath of ozone layer depletion is that it should be a non-Ozone Depleting Substance (non-ODS). Out of this requirement two alternatives have emerged. The first one is to look for zero ODP synthetic refrigerants and the second one is to look for "natural" substances. Introduction of *hydrofluorocarbons* (HFCs) and their mixtures belong to the first route, while the re-introduction of carbon dioxide (in a supercritical cycle), water and various hydrocarbons and their mixtures belong to the second route. The increased use of ammonia and use of other refrigeration cycles such as air cycle refrigeration systems and absorption systems also come under the second route. Both these routes have found their proponents and opponents. HFC-134a (synthetic substance) and hydrocarbons (natural substances) have emerged as alternatives to Freon-12. No clear pure fluid alternative has been found as yet for the other popular refrigerant HCFC-22. However several mixtures consisting of synthetic and natural refrigerants are being used and suggested for future use. Table 2.1 shows the list of refrigerants being replaced and their alternatives. Mention must be made here about the other

environmental problem, global warming. In general the non-ODS synthetic refrigerants such as HFC-134a have high global warming potential (GWP), hence they face an uncertain future. Since the global warming impact of a refrigerant also depends on the energy efficiency of the system using the refrigerant (indirect effect), the efficiency issue has become important in the design of new refrigeration systems. Though the issues of ozone layer depletion and global warming has led to several problems, they have also had beneficial effects of making people realize the importance of environmental friendliness of technologies. It is expected that with the greater awareness more responsible designs will emerge which will ultimately benefit the whole mankind.

Refrigerant	Composition	Normal Boiling Point (NBP) (°C)*	Ozone Depletion Potential (ODP) (R11=1)	Global Warming Potential (GWP) (CO <sub>2</sub> =1)	Retrofit or New
<b>Example Candidate Replacements for CFC-11</b>					
<i>CFC-11</i>		23.8	1.0	3800	
HCFC-123		27.9	0.020	90	Both
HCFC-141b		32.2	0.110	630	New
HFC-245fa		15.3	0	900	New
n-pentane		36.19	0	0	Both
<b>Example Candidate Replacements for CFC-114</b>					
<i>CFC-114</i>		3.78	0.8	9300	
HCFC-124		-13.2	0.022	480	Both
HFC-134		4.67	0	1300	New
R600		-0.45	0	0	Both
<b>Example Candidate Replacements for CFC-12</b>					
<i>CFC-12</i>		-29.79	1	8100	
HFC-134a		-26.1	0	1300	New
R401A	R22/152a/124 (53/13/34)	-33.0/6.3	0.037	1100	Both
R409A	R22/124/142b (60/25/15)	-34.3/8.5	0.048	1400	Both
propane-ethane	R290/170 (43/57)	-31.9/7.9	0	3	Both
<b>Example Candidate Replacements for HCFC-22</b>					
<i>HCFC-22</i>		-40.75	0.055	1700	
R407C	R32/125/134a (23/25/52)	-44.0/7.2	0	1600	Both
R410A	R32/125	-52.7/<0.1	0	1900	New
	R23/32/134a	-43.0/10.2	0	1600	New
propane-ethane	R290/170 (95/5)	-49.3/7.9	0	3	Both
<b>Example Candidate Replacements for R502</b>					
<i>R502</i>	<i>CFC115/HCFC22 (48.8/51.2)</i>	-45.6 azeo		5500	
R404a	R125/143a/134a (44/52/4)	-46.5/0.8	0	3700	Both
R507	R125/143a (50/50)	-46.7 azeo	0	3800	Both
	R32/125/143a (10/45/45)	-49.7/0.9	0	3500	Both
propane-ethane	R290/170 (95/5)	-49.3/7.9	0	3	Both
<b>Other Options - Natural Refrigerants</b>					
Air			0	0	
Water			0	?	
Ammonia			0	0	
Carbon dioxide			0	1	

\* or bubble point /temperature glide for mixtures. Temperature glide =  $T_{dew} - T_{bubble}$

Table 2.1. Candidate refrigerants for replacing CFCs



**Q.** Ethyl ether was the first refrigerant to be used commercially, because:

- a) It exists as liquid at ambient conditions
- b) It is safe
- c) It is inexpensive
- d) All of the above

**Ans.** a)

**Q.** Ammonia is one of the oldest refrigerants, which is still used widely, because:

- a) It offers excellent performance
- b) It is a natural refrigerant
- c) It is inexpensive
- d) All of the above

**Ans.** d)

**Q.** In the olden days Carbon dioxide was commonly used in marine applications as:

- a) It has low critical temperature
- b) Its operating pressures are high
- c) It is non-toxic and non-flammable
- d) It is odorless

**Ans.** c)

**Q.** Sulphur dioxide was mainly used in small refrigeration systems, because:

- a) It is non-toxic and non-flammable
- b) It has small refrigeration effect
- c) It is expensive
- d) It was easily available

**Ans.** b)

**Q.** Need for synthetic refrigerants was felt, as the available natural refrigerants:

- a) Were not environment friendly
- b) Suffered from several perceived safety issues
- c) Were expensive
- d) Were inefficient

**Ans.** b)

**Q.** The synthetic CFC based refrigerants were developed by:

- a) Partial replacement of hydrogen atoms in hydrocarbons by chlorine, fluorine etc.
- b) Modifying natural refrigerants such as carbon dioxide, ammonia
- c) Modifying inorganic compounds by adding carbon, fluorine and chlorine
- d) Mixing various hydrocarbons

**Ans.** a)

**Q.** The synthetic refrigerants were extremely popular as they are:

- a) Environment friendly
- b) Mostly non-toxic and non-flammable
- c) Chemically stable
- d) Inexpensive

**Ans.** b) and c)

**Q.** CFC based refrigerants are being replaced as they are found to:

- a) Cause ozone layer depletion
- b) Consume more energy
- c) React with several materials of construction
- d) Expensive

**Ans.** a)

## 2.3. Compressor development – a brief history

Compressor may be called as a heart of any vapour compression system. The rapid development of refrigeration systems is made possible due to the developments in compressor technologies.

### 2.3.1. Reciprocating compressors:

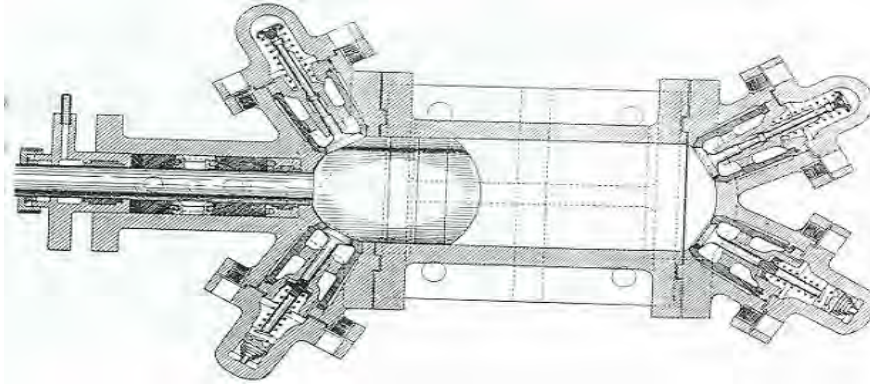
The earliest compressor used by Jakob Perkins is a hand-operated compressor, very much like a hand operated pump used for pumping water. Harrison also used a hand-operated ether compressor in 1850, but later used steam engine driven compressors in commercial machines. A small half horsepower (hp) compressor was used as early as 1857 to produce 8 kg of ice per hour. Three other machines with 8 to 10 hp were in use in England in 1858. In 1859, the firm P.N. Russel of Australia undertook the manufacture of Harrison's machines, the first compressors to be made with two vertical cylinders. The firm of Siebe brothers of England went on perfecting the design of the early compressors. Their first compressors were vertical and the later were horizontal. From 1863 to 1870, Ferdinand Carre of France took out several patents on diaphragm compressors, valves etc.

Charles Tellier used a horizontal single cylinder methyl ether compressor in 1863. These compressors were initially installed in a chocolate factory near Paris and in a brewery in USA in 1868. In 1876 the ship "Le Frigorifique" was equipped with three of Tellier's methyl ether compressors and successfully transported chilled meat from Rouen in France to Buenos Ayres in Argentina (a distance of 12000 km).

T.S.C. Lowe (1832-1913) started making carbon dioxide compressors in 1865, and began to use them in the manufacture of ice from 1868. However, the credit for perfecting the design of carbon dioxide compressor goes to Franz Windhausen of Germany in 1886. The British firm J&E Hall began the commercial production of carbon dioxide compressors in 1887. They started manufacturing two-stage carbon dioxide compressors since 1889. Soon the carbon dioxide systems replaced air cycle refrigeration systems in ships. Several firms started manufacturing these compressors on a large scale. This trend continued upto the Second World War.

A significant development took place in 1876 by the introduction of a twin cylinder vertical compressor working with ammonia by Carl von Linde. Similar to his earlier methyl ether compressor (1875) a bath of liquid mercury was used to make the compressor gas-tight. This ammonia compressor was installed in a brewery in 1877 and worked there till 1908. In 1877, Linde improved the compressor design by introducing a horizontal, double acting cylinder with a stuffing box made from two packings separated by glycerine (glycerine was later replaced by mineral oil). Figure 2.1 shows the schematic of Linde's horizontal, double acting compressor. This design became very successful, and was a subject of many patents. Several manufacturers in other countries adopted this design and manufactured several of these compressors. USA began the production of ammonia compressors on a large scale from 1880.

Raoul Pictet invented the sulphur dioxide compressor in 1874. The machine was initially built in Geneva, then in Paris and afterwards in some other countries. The compressor developed by Pictet was horizontal and was not lubricated as sulphur dioxide acts



*Fig.2.1. Schematic of Linde's horizontal, double acting compressor*

as an auto-lubricant. As mentioned before, the sulphur dioxide system was an instant success and was used for almost sixty years, especially in small systems.

In 1878, methyl chloride system was introduced by Vincent in France. The French company Crespin & Marteau started manufacturing methyl chloride compressors from 1884. This continued up to the first world war. Escher Wyss of USA started making these compressors from 1913 onwards, right up to the Second World War.

At the beginning of 20<sup>th</sup> century, practically all the compressors in USA, Great Britain and Germany used either ammonia or carbon dioxide. In France, in addition to these two, sulphur dioxide and methyl chloride were also used. Compressor capacity comparison tests have been conducted on different types of compressors as early as 1887 in Munich, Germany. Stetefeld in 1904 concluded that there was no marked difference in the performance of ammonia, carbon dioxide and sulphur dioxide compressors.

Due to many similarities, the early compressors resembled steam engines in many ways. Like early steam engines, they were double acting (compression takes place on both sides of the piston). Both vertical and horizontal arrangements were used, the former being popular in Europe while the later was popular in USA. A stuffing box arrangement with oil in the gap was used to reduce refrigerant leakage. The crosshead, connecting rod, crank and flywheel were in the open. Initially poppet valves were used, which were later changed to ring-plate type. The cylinder diameters were very large by the present day standards, typically around 500 mm with stroke lengths of the order of 1200 mm. The rotational speeds were low (~ 50 rpm), hence the clearances were small, often less than 0.5 % of the swept volume. Due to generous valve areas and low speed the early compressors were able to compress mixture of vapour as well as liquid. Slowly, the speed of compressors have been increased, for example for a 300 kW cooling capacity system, the mean speed was 40 rpm in 1890, 60 in 1900, 80 in 1910, 150 to 160 in 1915, and went up to 220 in 1916. The term "high speed" was introduced in 1915 for compressors with speeds greater than 150 rpm. However, none of the compressors of this period exceeded speeds of 500 rpm. However, compressors of very large capacities (upto 7 MW cooling capacity) were successfully built and operated by this time. In 1905 the American engineer G.T. Voorhees introduced a dual effect compressor, which has a supplementary suction orifice opened during compression so that refrigerant can be taken in at two different pressures. As mentioned, the first two-stage carbon dioxide compressor was made in 1889 by J&E Hall of England. Sulzer Company developed the first two-stage ammonia compressor in 1889. York Company of USA made a two-stage ammonia compressor in 1892.

About 1890, attention was focused on reducing the clearance space between the piston and cylinder head (clearance space) in order to increase the capacity of the compressors. Attention was also focused on the design of stuffing box and sealing between piston and cylinder to reduce refrigerant leakage. In 1897 the Belgian manufacturer Bruno Lebrun introduced a rotary stuffing box, which was much easier to seal than the reciprocating one. A rotating crankshaft enclosed in a crankcase drove the two opposed horizontal cylinders. Many studies were also conducted on compressor valves as early as 1900. By 1910, the heavy bell valves were replaced by much lighter, flat valves. By about 1900, the design of stuffing box for large compressors was almost perfected. However, for smaller compressors the energy loss due to friction at the stuffing box was quite high. This fact gave rise to the idea of sealed or hermetic compressor (both compressor and motor are mounted in the same enclosure). However, since the early electric motors with brushes and commutator and primitive insulation delayed the realization of hermetic compressors upto the end of First World War.

As mentioned, the earliest compressors were hand operated. Later they were driven by steam engines. However, the steam engines gradually gave way to electric motors. Diesel and petrol engine driven compressors were developed much later. In USA, 90% of the motive power was provided by the steam engine in 1914, 71% in 1919, 43% in 1922 and 32% in 1924. This trend continued and slowly the steam engine driven compressors have become almost obsolete. Between 1914 and 1920, the electric motor was considered to be the first choice for refrigerant compressors.

About 1920, high-speed compressors (with speeds greater than 500 rpm) began to appear in the market. The horizontal, double acting compressors were gradually replaced by multi-cylinder, vertical, uni-flow compressors in V- and W- arrangement, the design being adopted from automobile engine design. In 1937, an American compressor (Airtemp) comprised two groups of 7 cylinders arranged radially at both ends of 1750 rpm electric motor. These changes resulted in a reduction of size and weight of compressor, for example, a York 300 000 kcal/h compressor had the following characteristics:

Year	Refrigerant	No. of cylinders	Speed (rpm)	Cooling capacity per unit weight
1910	NH <sub>3</sub>	2 cylinders	70	6.5 kcal/h per kg
1940	NH <sub>3</sub>	4 cylinders	400	42 kcal/h per kg
1975	R22	16 cylinders in W-arrangement	1750	200 kcal/h per kg

All the compressors developed in the early stages are of “open” type. In the open type compressors the compressor and motor are mounted separately. The driving shaft of the motor and the crankshaft of the compressor are connected either by a belt drive or a gear drive. With the open type compressors there is always a possibility of refrigerant leakage from an open type compressor, even though the rotating mechanical seals developed reduced the leakage rate considerably. Since leakage cannot be eliminated completely, systems working with open type compressors require periodic servicing and maintenance. Since it is difficult to provide continuous maintenance on small systems (e.g. domestic refrigerators), serious thought was given to tackle this problem. A hermetic or sealed compressor was the outcome of this.

An Australian Douglas Henry Stokes made the first sealed or [hermetic compressor](#) in 1918. Hermetic compressors soon became extremely popular, and the rapid development of small hermetic compressors has paved the way for taking the refrigeration systems to the households. With the capacitor starting of the electric motor becoming common in 1930s, the design of hermetic compressors was perfected. In 1926, General Electric Co. of USA introduced the domestic refrigerator working with a hermetic compressor. Initially 4-pole motors were used. After 1940 the 4-pole motors were replaced by 2-pole motors, which reduced of the compressor unit significantly. Soon the 2-pole hermetic refrigerant compressor became universal. Gradually, the capacity of hermetic compressors was increased. Now-a - days hermetic compressors are available for refrigerating capacities starting from a few Watts to kilowatts. At present, due to higher efficiency and serviceability, the open type compressors are used in medium to large capacity systems, whereas the hermetic compressors are exclusively used in small capacity systems on a mass production. The currently available hermetic compressors are compact and extremely reliable. They are available for a wide variety of refrigerants and applications. Figure 2.2 shows cut view of a hermetic compressor.



*Fig.2.2. Cut view of a hermetic compressor*

Other types of compressors:

2.3.2. [Positive displacement type](#) (other than reciprocating):

In 1919, the French engineer Henri Corblin (1867-1947) patented a diaphragm compressor, in which the alternating movement of a diaphragm produced the suction and compression effects. Initially these compressors were used for liquefying chlorine, but later were used in small to medium capacity systems working with ammonia, carbon dioxide etc.

Several types of rotary air compressors existed before the First World War, and this idea has soon been extended to refrigerants. However, they became popular with the introduction of Freons in 1930s. The first positive displacement, rotary vane compressor using methyl chloride was installed on an American ship “Carnegie”. However, a practical

positive displacement, rotary vane compressor could only be developed in 1920. In Germany, F. Stamp made an ethyl chloride compressor of 1000 kcal/h capacity. In USA, Sunbeam Electric made small sulphur dioxide based rotary sliding vane compressors of 150 kcal/h capacity, rotating at 1750 rpm for domestic refrigerators. In 1922, Sulzer, Switzerland made “Frigorotor” of 1000 to 10000 kcal/h using methyl chloride. Sulzer later extended this design to ammonia for large capacities (“Frigocentrale”). Escher Wyss, also of Switzerland rotary sliding vane compressor “Rotasco” in 1936. These compressors were also made by Lebrun, Belgium in 1924 and also by Grasso (Netherlands).

A model of the rolling piston type compressor was made in 1919 in France. This compressor was improved significantly by W.S.F. Rolaff of USA in 1920 and M. Guttner of Germany in 1922. Rolaff’s design was first tried on a sulphur dioxide based domestic refrigerator. Guttner’s compressors were used with ammonia and methyl chloride in large commercial installations. Hermetic, rolling piston type compressors were made in USA by Frigidaire for refrigerant R114, by General Electric for ethyl formate and by Bosch in Germany for sulphur dioxide. In 1931, Vilter of USA made large rotary compressors (200000 kcal/h) first for ammonia and then for R12.

At present, positive displacement rotary compressors based on sliding vane and rolling piston types are used in small to medium capacity applications all over the world. These compressors offer the advantages of compactness, efficiency, low noise etc. However, these compressors require very close manufacturing tolerances as compared to reciprocating compressors. Figure 2.3 shows the schematic of a rolling piston compressor. The low pressure refrigerant from the evaporator enters into the compressor from the port on the right hand side, it gets compressed due to the rotation of the rolling piston and leaves the compressor from the discharge valve on the left hand side.

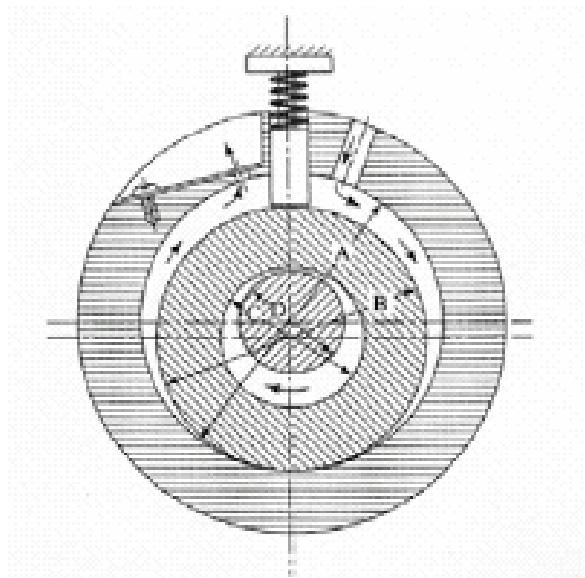


Fig.2.3. Schematic of a rolling piston type, rotary compressor

The screw compressor is another important type of positive displacement compressor. The screw compressors entered into refrigeration market in 1958, even though the basic idea goes back to 1934, by A. Lysholm of Sweden. The screw compressors are of twin-screw

(two helical rotors) type or a single-screw (single rotor) type. The twin-screw compressor uses a pair of intermeshing rotors instead of a piston to produce compression. The rotors comprise of helical lobes fixed to a shaft. One rotor is called the male rotor and it will typically have four bulbous lobes. The other rotor is the female rotor and this has valleys machined into it that match the curvature of the male lobes. Typically the female rotor will have six valleys. This means that for one revolution of the male rotor, the female rotor will only turn through 240 deg. For the female rotor to complete one cycle, the male rotor will have to rotate 1 1/2 times. The single screw type compressor was first made for air in 1967. Grasso, Netherlands introduced single screw refrigerant compressors in 1974. The screw compressor (both single and twin screw) became popular since 1960 and its design has almost been perfected. Presently it is made for medium to large capacity range for ammonia and fluorocarbon based refrigerants. It competes with the reciprocating compressors at the lower capacity range and on the higher capacity side it competes with the centrifugal compressor. Due to the many favorable performance characteristics, screw compressors are taking larger and larger share of refrigerant compressor market. Figure 2.4 shows the photograph of a cut, semi-hermetic, single-screw compressor.

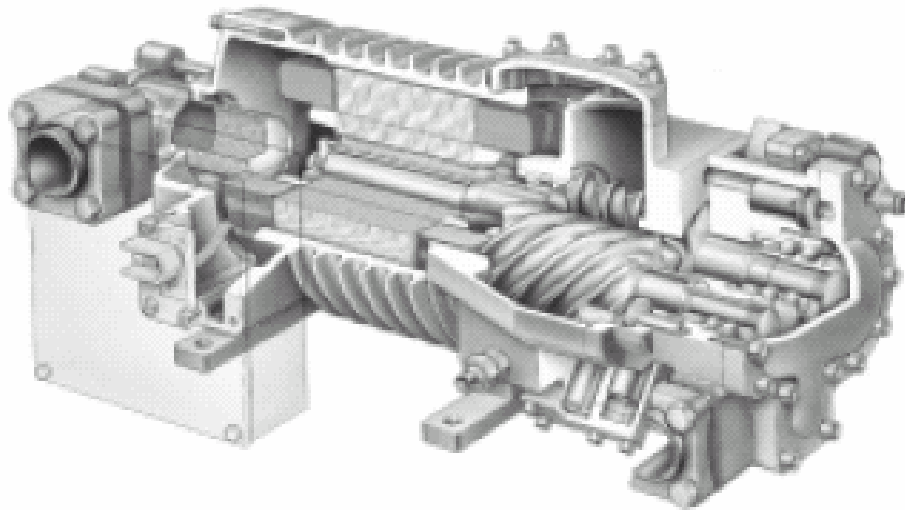


Fig.2.4. Cut view of a semi-hermetic, single-screw compressor

The scroll compressor is one of the more recent but important types of positive displacement compressors. It uses the compression action provided by two intermeshing scrolls - one fixed and the other orbiting. This orbital movement draws gas into the compression chamber and moves it through successively smaller “pockets” formed by the scroll’s rotation, until it reaches maximum pressure at the center of the chamber. There, it’s released through a discharge port in the fixed scroll. During each orbit, several pockets are compressed simultaneously, so operation is virtually continuous. Figure 2.5 shows gas flow pattern in a scroll compressor and Fig.2.6 shows the photograph of a Copeland<sup>1</sup> scroll compressor. The principle of the scroll compressor was developed during the early 1900's and was patented for the first time in 1905. Although the theory for the scroll compressor indicated a machine potentially capable of reasonably good efficiencies, at that time the technology simply didn't exist to accurately manufacture the scrolls. It was almost 65 years later that the concept was re-invented by a refrigeration industry keen to exploit the potentials

of scroll technology. Copeland in USA, Hitachi in Japan introduced the scroll type of compressors for refrigerants in 1980s. Scroll compressors have been developed for operating temperatures in the range of  $-45^{\circ}\text{C}$  to  $+5^{\circ}\text{C}$  suitable for cold storage and air conditioning applications. This scroll has also been successfully applied throughout the world in many freezer applications. Today, scroll compressors are very popular due to the high efficiency, which results from higher compression achieved at a lower rate of leakage. They are available in cooling capacities upto 50 kW. They are quiet in operation and compact. However, the manufacturing of scroll compressors is very complicated due to the extremely close tolerances to be maintained for proper operation of the compressor.

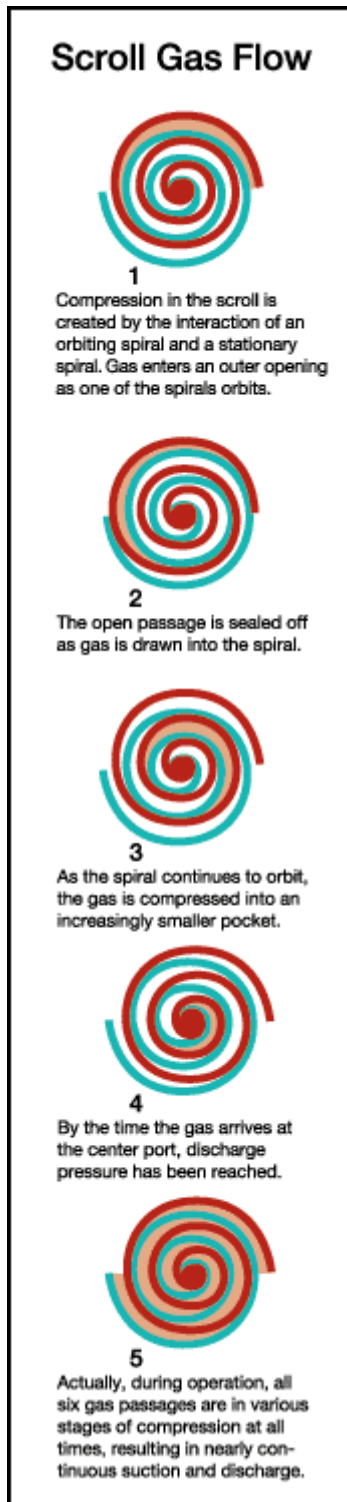


Fig.2.6. Photograph of a cut scroll compressor (Copeland)

Fig.2.5. Gas flow in a scroll compressor



### 2.3.3. Dynamic type:

Centrifugal compressors (also known as turbocompressors) belong to the class of dynamic type of compressors, in which the pressure rise takes place due to the exchange of angular momentum between the rotating blades and the vapour trapped in between the blades. Centrifugal were initially used for compressing air. The development of these compressors is largely due to the efforts of Auguste Rateau of France from 1890. In 1899, Rateau developed single impeller (rotor) and later multi-impeller fans. Efforts have been made to use similar compressors for refrigeration. In 1910, two Germans H. Lorenz and E. Elgenfeld proposed the use of centrifugal compressors for refrigeration at the International Congress of Refrigeration, Vienna. However, it was Willis H. Carrier, who has really laid the foundation of centrifugal compressors for air conditioning applications in 1911. The motivation for developing centrifugal compressors originated from the fact that the reciprocating compressors were slow and bulky, especially for large capacity systems. Carrier wanted to develop a more compact system working with non-flammable, non-toxic and odorless refrigerant. In 1919, he tried a centrifugal compressor with dichloroethylene ( $C_2H_2Cl_2$ ) and then dichloromethane ( $CCl_2H_2$ ). In 1926 he used methyl chloride, and in 1927 he had nearly 50 compressors working with dichloroethylene. The centrifugal compressors really took-off with the introduction of Freons in 1930s. Refrigerant R11 was the refrigerant chosen by Carrier for his centrifugal compressor based air conditioning systems in 1933. Later his company developed centrifugal compressors working with R12, propane and other refrigerants for use in low temperature applications. In Switzerland, Brown Boveri Co. developed ammonia based centrifugal compressors as early as 1926. Later they also developed large centrifugal compressors working with Freons. Till 1950, the centrifugal compressors were used mainly in USA for air conditioning applications. However, subsequently centrifugal compressors have become industry standard for large refrigeration and air conditioning applications all over the world. Centrifugal compressors developed before 1940, had 5 to 6 stages, while they had 2 to 3 stages between 1940 to 1960. After 1960, centrifugal compressors with a single stage were also developed. Subsequently, compact, hermetic centrifugal compressor developed for medium to large capacity applications. The large diameter, 3600 rpm machines were replaced by compact 10000 to 12000 rpm compressors. Large centrifugal compressors of cooling capacities in the range of 200000 kcal/h to 2500000 kcal/h were used in places such as World Trade Centre, New York. Figure 2.7 shows cut-view of a two-stage, semi-hermetic centrifugal compressor.

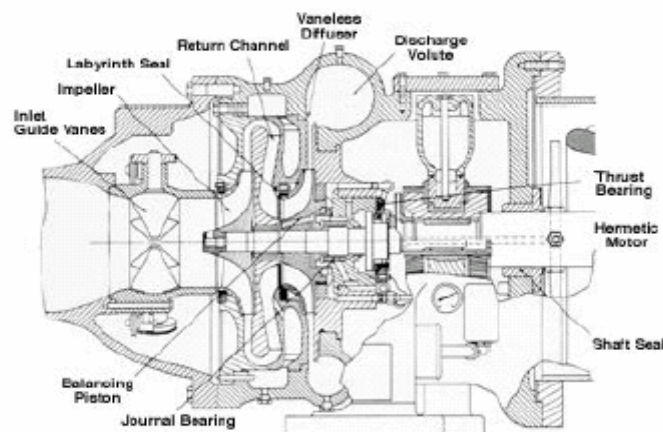


Fig. 2.7 Cut-view of a two-stage, semi-hermetic centrifugal compressor.

**Q.** The early refrigerant compressor design resembled:

- a) Automobile engines
- b) Steam engines
- c) Water pumps
- d) None of the above

**Ans.** b)

**Q.** The early compressors were able to handle liquid and vapour mixtures as they were:

- a) Double acting, reciprocating type
- b) Horizontally oriented
- c) Low speed machines
- d) Steam engine driven

**Ans.** c)

**Q.** The speed of the compressors was increased gradually with a view to:

- a) Develop compact compressors
- b) Reduce weight of compressors
- c) Handle refrigerant vapour only
- d) All of the above

**Ans.** a) and b)

**Q.** Hermetic compressors were developed to:

- a) Improve energy efficiency
- b) Overcome refrigerant leakage problems
- c) Improve serviceability
- d) Reduce weight

**Ans.** b)

**Q.** Open type compressors are used in:

- a) Domestic refrigeration and air conditioning
- b) Large industrial and commercial refrigeration systems
- c) Only CFC based refrigeration systems
- d) Only in natural refrigerant based systems

**Ans.** b)

**Q.** At present the reciprocating type compressors are most common as they are:

- a) Rugged
- b) Comparatively easy to manufacture
- c) Offer higher energy efficiency
- d) All of the above

**Ans.** a) and b)

**Q.** Which of the following are positive displacement type compressors:

- a) Reciprocating compressors
- b) Scroll compressors
- c) Screw compressors
- d) Centrifugal compressors

**Ans.** a), b) and c)

**Q.** Centrifugal compressors are used in:

- a) Large refrigerant capacity systems
- b) In small refrigerant capacity systems
- c) Domestic refrigeration and air conditioning
- d) All of the above

**Ans.** a)

## 2.4. Conclusions:

The compressor technology has undergone significant developments in the last hundred years. Almost all the compressors described so far have reached a high level of perfection. Today different compressors are available for different applications, starting from small hermetic reciprocating and rotary compressors for domestic refrigerators to very large screw and centrifugal compressors for huge industrial and commercial refrigeration and air conditioning applications. However, development is a never-ending process, and efforts are going on to develop more efficient compact, reliable and quiet compressors. Also some new types such as linear compressors, trochoidal compressors, acoustic compressors are being introduced in refrigeration and air conditioning applications. A brief history of refrigeration and air conditioning from the refrigerant and compressor development points of view has been discussed in the present lesson. The actual characteristics and performance aspects of some important refrigerants and compressors will be discussed in subsequent lessons.

**Q.** State briefly the impact of Freons (CFCs) on refrigeration and air conditioning

**Ans.:** Freons have contributed significantly to the widespread use of refrigeration and air condition systems as the systems using these refrigerants were thought to be safe, reliable and rugged. The rapid growth of domestic refrigerators and air conditioners all over the world can be attributed at least partly to the non-toxic, non-flammable and chemically stable nature of Freons. Of course, Freons are also responsible for the monopoly of few companies in refrigeration technology. Of late, the biggest impact of Freons could be their contribution to global environmental hazards such as ozone layer depletion and global warming.

**Q.** How do the natural refrigerants compare with the synthetic refrigerants?

**Ans.** Almost all the natural refrigerants are non-ozone depleting substances and they also have comparatively low global warming potential. Natural refrigerants generally offer good thermodynamic and thermophysical properties leading to energy efficient systems. They are also relatively inexpensive, and cannot be monopolized by few companies in the developed world. However, unlike synthetic refrigerants the natural refrigerants suffer from some specific problems related to toxicity, flammability, limited operating temperature range etc.

**Q.** What are the motivations for developing hermetic compressors? Why they are not used for large capacity systems?

**Ans.** Hermetic compressors were developed to take care of the problem of refrigerant leakage associated with the open type of compressors. By eliminating refrigerant leakage, the hermetic compressor based systems were made relatively maintenance free, which is one of the main requirement of small systems such as domestic refrigerators, air conditioners etc. Hermetic compressors are not used in large capacity systems, as they are not completely serviceable, they offer lower energy efficiency and compressor and motor cooling is difficult.

# Lesson

3

## Applications Of Refrigeration & Air Conditioning

## Objectives of the lesson:

The objectives of this lesson are to introduce the student to:

### i. Applications of refrigeration in:

- a) Food processing, preservation and distribution (*Section 3.2*)
- b) Chemical and process industries (*Section 3.3*)
- c) Special Applications such as cold treatment of metals, medical, construction, ice skating etc. (*Section 3.4*)
- d) Comfort air-conditioning (*Section 3.5*)

### ii. Applications of air conditioning, namely:

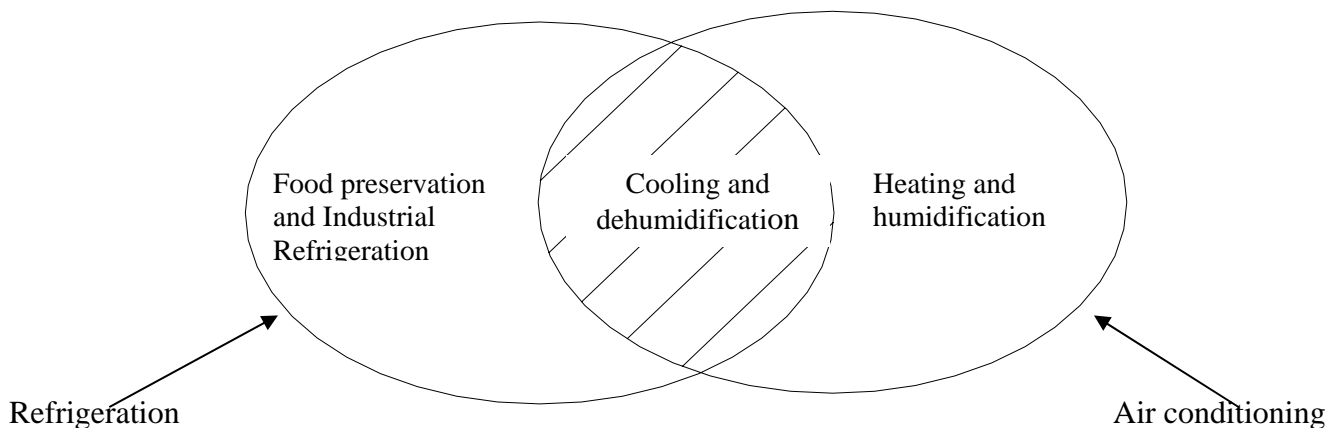
- a) Industrial, such as in textiles, printing, manufacturing, photographic, computer rooms, power plants, vehicular etc. (*Section 3.5.1*)
- b) Comfort – commercial, residential etc. (*Section 3.5.2*)

At the end of the lesson, the student should be able to:

- a) List various applications of refrigeration and air conditioning
- b) List typical conditions required for various food products, processes etc.
- c) State pertinent issues such as energy efficiency, Indoor Air Quality etc.

## 3.1. Introduction

As mentioned in Lesson 1, refrigeration deals with cooling of bodies or fluids to temperatures lower than those of surroundings. This involves absorption of heat at a lower temperature and rejection to higher temperature of the surroundings. In olden days,



**Fig.3.1.** Relation between refrigeration and air conditioning

the main purpose of refrigeration was to produce ice, which was used for cooling beverages, food preservation and refrigerated transport etc. Now-a-days refrigeration and air conditioning find so many applications that they have become very essential for mankind, and without refrigeration and air conditioning the basic fabric of the society will be adversely affected. Refrigeration and air conditioning are generally treated in a single subject due to the fact that one of the most important applications of refrigeration is in cooling and dehumidification as required for [summer air conditioning](#). Of course, refrigeration is required for many applications other than air conditioning, and air conditioning also involves processes other than cooling and dehumidification. Figure 3.1 shows the relation between refrigeration and air conditioning in a pictorial form.

The temperature range of interest in refrigeration extends down to about  $-100^{\circ}\text{C}$ . At lower temperatures [cryogenic systems](#) are more economical. Now-a-days refrigeration has become an essential part of food chain- from post harvest heat removal to processing, distribution and storage. Refrigeration has become essential for many chemical and processing industries to improve the standard, quality, precision and efficiency of many manufacturing processes. Ever-new applications of refrigeration arise all the time. Some special applications require small capacities but are technically intriguing and challenging.

As mentioned before, air-conditioning is one of the major applications of refrigeration. Air-conditioning has made the living conditions more comfortable, hygienic and healthy in offices, work places and homes. As mentioned in Lesson 1, air-conditioning involves control of temperature, humidity, cleanliness of air and its distribution to meet the comfort requirements of human beings and/or some industrial requirements. Air-conditioning involves cooling and dehumidification in summer months; this is essentially done by refrigeration. It also involves heating and humidification in cold climates, which is conventionally done by a boiler unless a [heat pump](#) is used.

The major applications of refrigeration can be grouped into following four major equally important areas.

1. Food processing, preservation and distribution
2. Chemical and process industries
3. Special Applications
4. Comfort air-conditioning

## 3.2. Application of refrigeration in Food processing, preservation and distribution

*3.2.1. Storage of Raw Fruits and Vegetables:* It is well-known that some bacteria are responsible for degradation of food, and enzymatic processing cause ripening of the fruits and vegetables. The growth of bacteria and the rate of enzymatic processes are reduced at low temperature. This helps in reducing the spoilage and improving the shelf life of the food. Table 3.1 shows useful storage life of some plant and animal tissues at various

temperatures. It can be seen that the storage temperature affects the useful storage life significantly. In general the storage life of most of the food products depends upon water activity, which essentially depends upon the presence of water in liquid form in the food product and its temperature. Hence, it is possible to preserve various food products for much longer periods under frozen conditions.

Food Product	Average useful storage life (days)		
	0°C	22°C	38°C
Meat	6-10	1	< 1
Fish	2-7	1	< 1
Poultry	5-18	1	< 1
Dry meats and fish	> 1000	> 350 & < 1000	> 100 & < 350
Fruits	2 - 180	1 - 20	1 - 7
Dry fruits	> 1000	> 350 & < 1000	> 100 & < 350
Leafy vegetables	3 - 20	1 - 7	1 - 3
Root crops	90 - 300	7 - 50	2 - 20
Dry seeds	> 1000	> 350 & < 1000	> 100 & < 350

*Table 3.1. Effect of storage temperature on useful storage life of food products*

In case of fruits and vegetables, the use of refrigeration starts right after harvesting to remove the post-harvest heat, transport in refrigerated transport to the cold storage or the processing plant. A part of it may be stored in [cold storage](#) to maintain its sensory qualities and a part may be distributed to retail shops, where again refrigeration is used for short time storage. Depending upon the size, the required capacity of refrigeration plants for cold storages can be very high. Ammonia is one of the common refrigerants used in cold storages. Figure 3.2 shows the photograph of ammonia based refrigerant plant for a cold storage. Figure 3.3 shows the photograph of a typical cold storage. [Household refrigerator](#) is the user end of cold chain for short time storage.



*Fig.3.2. Ammonia based refrigeration plant for a large cold storage*



*Fig.3.3. Photograph of a typical cold storage*

The cold chain has proved to be very effective in reducing spoilage of food and in food preservation. It is estimated that in India, the post-harvest loss due to inadequate cold storage facilities is high as 30 percent of the total output. The quality of remaining 70 percent is also affected by inadequate cold chain facilities. This shows the importance of proper refrigeration facilities in view of the growing food needs of the ever-growing population. Refrigeration helps in retaining the sensory, nutritional and eating qualities of the food. The excess crop of fruits and vegetables can be stored for use during peak demands and off-season; and transported to remote locations by refrigerated transport. In India, storage of potatoes and apples in large scale and some other fruits and vegetables in small scale and frozen storage of peas, beans, cabbage, carrots etc. has improved the standard of living. In general, the shelf life of most of the fruits and vegetables increases by storage at temperatures between 0 to 10°C. Table 3.2 shows the typical storage conditions for some fruits and vegetables as recommended by [ASHRAE](#). Nuts, dried fruits and pulses that are prone to bacterial deterioration can also be stored for long periods by this method. The above mentioned fruits, vegetables etc, can be stored in raw state. Some highly perishable items require initial processing before storage. The fast and busy modern day life demands ready-to-eat frozen or refrigerated food packages to eliminate the preparation and cooking time. These items are becoming very popular and these require refrigeration plants.

*3.2.2. Fish:* Icing of fish according to ASHRAE Handbook on Applications, started way back in 1938. In India, iced fish is still transported by rail and road, and retail stores store it for short periods by this method. Freezing of fish aboard the ship right after catch results in better quality than freezing it after the ship docks. In some ships, it is frozen along with seawater since it takes months before the ships return to dock. Long-term preservation of fish requires cleaning, processing and freezing.



	Storage Temperature, °C	Relative Humidity, %	Maximum, recommended storage time	Storage time in cold storages for vegetables in tropical countries
Apples	0 – 4	90 – 95	2 - 6 months	-
Beetroot	0	95 – 99	4 – 6 months	
Cabbage	0	95 – 99	5 – 6 months	2 months
Carrots	0	98 – 100	5 – 9 months	2 months
Cauliflower	0	95	3 – 4 weeks	1 week
Cucumber	10 - 13	90 – 95	10 – 14 days	
Eggplant	8 - 12	90 – 95	7 days	
Lettuce	0	95 – 100	2 – 3 weeks	
Melons	7 - 10	90 - 95	2 weeks	
Mushrooms	0 - 4	95	2 - 5	1 day
Onions	0	65 - 70	6 – 8 months	
Oranges	0 - 4	85 - 90	3 – 4 months	
Peas, Green	0	95 - 98	1 – 2 weeks	
Pears	0	90 - 95	2 – 5 months	
Potatoes	4 - 16	90 - 95	2 – 8 months	
Pumpkin	10 - 13	70 – 75	6 – 8 months	
Spinach	0	95	1 – 2 weeks	1 week
Tomatoes	13 - 21	85 - 90	1 – 2 weeks	1 week

*Table 3.2. Recommended storage conditions for fruits and vegetables*

3.2.3. *Meat and poultry*: These items also require refrigeration right after slaughter during processing, packaging. Short-term storage is done at 0°C. Long-term storage requires freezing and storage at -25°C.

3.2.4. *Dairy Products*: The important dairy products are milk, butter, buttermilk and ice cream. To maintain good quality, the milk is cooled in bulk milk coolers immediately after being taken from cow. Bulk milk cooler is a large refrigerated tank that cools it between 10 to 15°C. Then it is transported to dairy farms, where it is pasteurized. Pasteurization involves heating it to 73°C and holding it at this temperature for 20 seconds. Thereafter, it is cooled to 3 to 4°C. The dairies have to have a very large cooling capacity, since a large quantity of milk has to be immediately cooled after arrival. During the lean period, the refrigeration plants of dairies are used to produce ice that is used during peak periods to provide cooling by melting. This reduces the required peak capacity of the refrigeration plant.

Ice cream manufacture requires pasteurization, thorough mixing, emulsification and stabilization and subsequently cooling to 4 to 5°C. Then it is cooled to temperature of about – 5 °C in a freezer where it stiffens but still remains in liquid state. It is packaged and hardened at –30 to –25°C until it becomes solid; and then it is stored at same temperature.

Buttermilk, curd and cottage cheese are stored at 4 to 10°C for increase of shelf life. Use of refrigeration during manufacture of these items also increases their shelf life. There are many varieties of cheese available these days. Adding cheese starter like lactic acid and several substances to the milk makes all of these. The whey is separated and solid part is cured for a long time at about 10°C to make good quality cheese.

3.2.5. *Beverages*: Production of beer, wine and concentrated fruit juices require refrigeration. The taste of many drinks can be improved by serving them cold or by adding ice to them. This has been one of the favourite past time of aristocracy in all the countries. Natural or man-made ice for this purpose has been made available since a very long time. Fruit juice concentrates have been very popular because of low cost, good taste and nutritional qualities. Juices can be preserved for a longer period of time than the fruits. Also, fruit juice concentrates when frozen can be more easily shipped and transported by road. Orange and other citrus juices, apple juice, grape juice and pineapple juice are very popular. To preserve the taste and flavor of juice, the water is driven out of it by boiling it at low temperature under reduced pressure. The concentrate is frozen and transported at –20°C.

Brewing and wine making requires fermentation reaction at controlled temperature, for example lager-type of beer requires 8 to 12°C while wine requires 27-30°C. Fermentation is an exothermic process; hence heat has to be rejected at controlled temperature.

3.2.6. *Candy*: Use of chocolate in candy or its coating with chocolate requires setting at 5-10°C otherwise it becomes sticky. Further, it is recommended that it be stored at low temperature for best taste.

3.2.7. *Processing and distribution of frozen food*: Many vegetables, meat, fish and poultry are frozen to sustain the taste, which nearly duplicates that of the fresh product. Freezing retains the sensory qualities of colour, texture and taste apart from nutritional qualities. The refrigeration systems for frozen food applications are very liberally designed, since the food items are frozen in shortest period of time. The sharp freezing with temperature often below –30°C, is done so that the ice crystals formed during freezing do not get sufficient time to grow and remain small and do not pierce the cell boundaries and damage them. Ready-to-eat frozen foods, packed dinners and bakery items are also frozen by this method and stored at temperatures of –25 to –20 °C for distribution to retail stores during peak demands or off-season demands.

Vegetables in this list are beans, corn, peas, carrots, cauliflower and many others. Most of these are blanched before freezing. There are various processes of freezing. *Blast freezers* give a blast of high velocity air at – 30°C on the food container. In *contact freezing*, the food is placed between metal plates and metal surfaces that are cooled to –30°C or lower. *Immersion freezing* involves immersion of food in low temperature brine. *Individual quick freezing (IQF)* is done by chilled air at very high velocities like 5-10 m/s that keeps the small vegetable particles or shrimp pieces floating in air without clumping, so that maximum area is available for heat transfer to individual particles. The

frozen particles can be easily packaged and transported. The refrigeration capacities in all the freezers are very large since freezing of large quantities is done in a very short time. Liquid nitrogen and carbon dioxide are also used for freezing.

Of late supermarket refrigeration is gaining popularity all over the world. At present this constitutes the largest sector of refrigeration in developed countries. In a typical supermarket a large variety of products are stored and displayed for sale. Since a wide variety of products are stored, the required storage conditions vary widely. Refrigeration at temperatures greater than  $0^{\circ}\text{C}$  and less than  $0^{\circ}\text{C}$  is required, as both frozen and fresh food products are normally stored in the same supermarket. Figure 3.4 shows the photograph of a section of a typical supermarket. Refrigeration systems used for supermarkets have to be highly reliable due to the considerable value of the highly perishable products. To ensure proper refrigeration of all the stored products, a large of refrigerant tubing is used, leading to large refrigerant inventory.



*Fig.3.4. Section of a supermarket with refrigerated display cases*

**Q.** Food products can be preserved for a longer time at low temperatures because:

- a) At low temperatures the bacterial activity is reduced
- b) Enzymatic activity is reduced at low temperatures
- c) Quality of food products improves at low temperatures
- d) All of the above

**Ans.:** a) and b)

**Q.** The cold chain is extremely useful as it:

- a) Makes seasonal products available throughout the year
- b) Reduces food spoilage
- c) Balances the prices
- d) All of the above

**Ans.:** d)

**Q.** The useful storage life of food products depends on:

- a) Storage temperature
- b) Moisture content in the storage
- c) Condition of food products at the time of storage
- d) All of the above

**Ans.:** d)

**Q.** Cold storages can be used for storing:

- a) Live products such as fruits, vegetables only
- b) Dead products such as meat, fish only
- c) Both live and dead products
- d) None of the above

**Ans.:** c)

**Q.** Fast freezing of products is done to:

- a) Reduce the cell damage due to ice crystal growth
- b) Reduce energy consumption of refrigeration systems
- c) Reduce bacterial activity
- d) All of the above

**Ans.:** a)

**Q.** Products involving fermentation reactions require refrigeration because:

- a) Fermentation process is exothermic
- b) Fermentation process is endothermic
- c) Fermentation has to be done at controlled temperatures
- d) All of the above

**Ans.:** a) and c)

**Q.** Supermarket refrigeration requires:

- a) Provision for storing a wide variety of products requiring different conditions
- b) Reliable refrigeration systems due to the high value of the perishable products
- c) Large refrigerant inventory due to long refrigerant tubing
- d) All of the above

**Ans.:** d)

### 3.3. Applications of refrigeration in chemical and process industries

The industries like petroleum refineries, petrochemical plants and paper pulp industries etc. require very large cooling capacities. The requirement of each industry-process wise and equipment-wise is different hence refrigeration system has to be customized and optimized for individual application. The main applications of refrigeration in chemical and process industries involve the following categories.

*3.3.1. Separation of gases:* In petrochemical plant, temperatures as low as  $-150^{\circ}\text{C}$  with refrigeration capacities as high as 10,000 [Tons of Refrigeration](#) (TR) are used for separation of gases by fractional distillation. Some gases condense readily at lower temperatures from the mixtures of hydrocarbon. Propane is used as refrigerant in many of these plants.

*3.3.2. Condensation of Gases:* some gases that are produced synthetically, are condensed to liquid state by cooling, so that these can be easily stored and transported in liquid state. For example, in synthetic ammonia plant, ammonia is condensed at  $-10$  to  $10^{\circ}\text{C}$  before filling in the cylinders, storage and shipment. This low temperature requires refrigeration.

*3.3.3. Dehumidification of Air:* Low humidity air is required in many pharmaceutical industries. It is also required for air liquefaction plants. This is also required to prevent static electricity and prevents short circuits in places where high voltages are used. The air is cooled below its dew point temperature, so that some water vapour condenses out and the air gets dehumidified.

*3.3.4. Solidification of Solute:* One of the processes of separation of a substance or pollutant or impurity from liquid mixture is by its solidification at low temperature. Lubricating oil is dewaxed in petroleum industry by cooling it below  $-25^{\circ}\text{C}$ . Wax solidifies at about  $-25^{\circ}\text{C}$ .

*3.3.5. Storage as liquid at low pressure:* Liquid occupies less space than gases. Most of the refrigerants are stored at high pressure. This pressure is usually their saturation pressure at atmospheric temperature. For some gases, saturation pressure at room temperature is very high hence these are stored at relatively low pressure and low temperature. For example natural gas is stored at 0.7 bar gauge pressure and  $-130^{\circ}\text{C}$ . Heat gain by the cylinder walls leads to boiling of some gas, which is compressed, cooled and expanded back to 0.7 bar gauge.

*3.3.6. Removal of Heat of Reaction:* In many chemical reactions, efficiency is better if the reaction occurs below room temperature. This requires refrigeration. If these reactions are exothermic in nature, then more refrigeration capacities are required. Production of viscose rayon, cellular acetate and synthetic rubber are some of the examples. Fermentation is also one of the examples of this.

3.3.7. *Cooling for preservation:* Many compounds decompose at room temperature or these evaporate at a very fast rate. Certain drugs, explosives and natural rubber can be stored for long periods at lower temperatures.

3.3.8. *Recovery of Solvents:* In many chemical processes solvents are used, which usually evaporate after reaction. These can be recovered by condensation at low temperature by refrigeration system. Some of the examples are acetone in film manufacture and carbon tetrachloride in textile production.

### 3.4. Special applications of refrigeration

In this category we consider applications other than chemical uses. These are in manufacturing processes, applications in medicine, construction units etc.

3.4.1. *Cold Treatment of Metals:* The dimensions of precision parts and gauge blocks can be stabilized by soaking the product at temperature around  $-90^{\circ}\text{C}$ . The hardness and wear resistance of carburized steel can be increased by this process. Keeping the cutting tool at  $-100^{\circ}\text{C}$  for 15 minutes can also increase the life of cutting tool. In deep drawing process the ductility of metal increases at low temperature. Mercury patterns frozen by refrigeration can be used for precision casting.

3.4.2. *Medical:* Blood plasma and antibiotics are manufactured by freeze-drying process where water is made to sublime at low pressure and low temperature. This does not affect the tissues of blood. Centrifuges refrigerated at  $-10^{\circ}\text{C}$ , are used in the manufacture of drugs. Localized refrigeration by liquid nitrogen can be used as anesthesia also.

3.4.3. *Ice Skating Rinks:* Due to the advent of artificial refrigeration, sports like ice hockey and skating do not have to depend upon freezing weather. These can be played in indoor stadium where water is frozen into ice on the floor. Refrigerant or brine carrying pipes are embedded below the floor, which cools and freezes the water to ice over the floor.

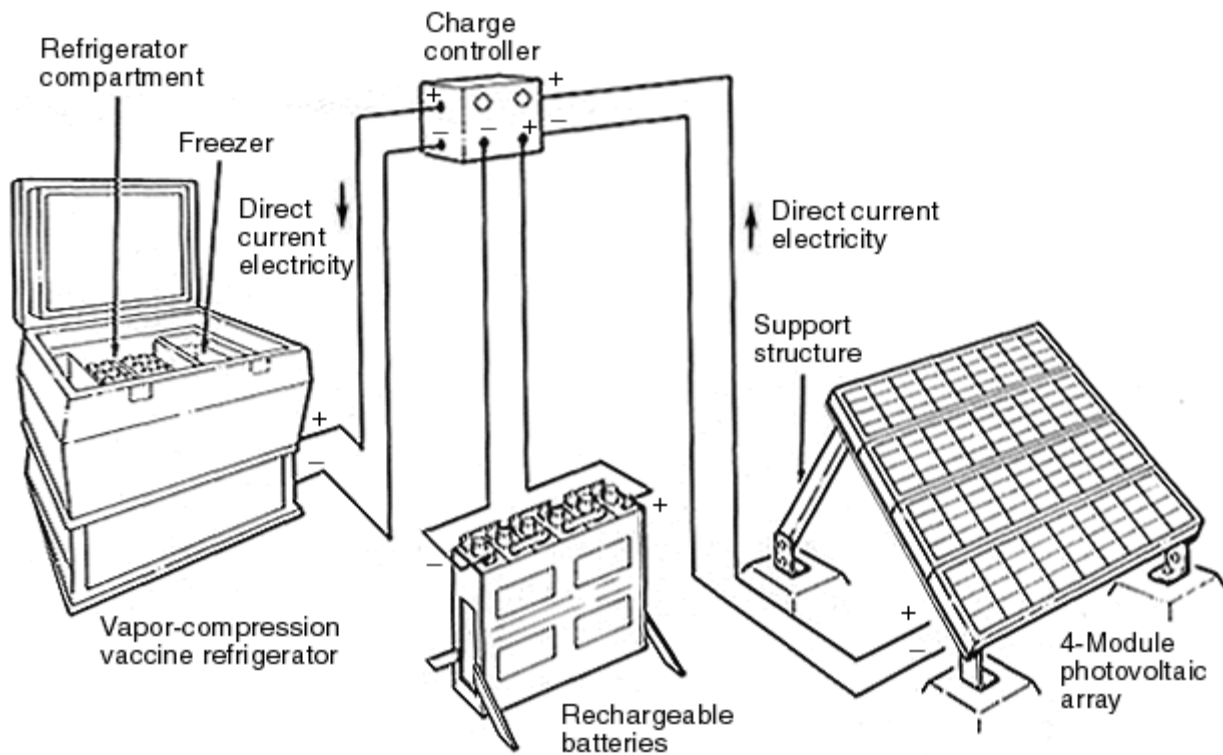
3.4.4. *Construction:* Setting of concrete is an exothermic process. If the heat of setting is not removed the concrete will expand and produce cracks in the structure. Concrete may be cooled by cooling sand, gravel and water before mixing them or by passing chilled water through the pipes embedded in the concrete. Another application is to freeze the wet soil by refrigeration to facilitate its excavation.

3.4.5. *Desalination of Water:* In some countries fresh water is scarce and seawater is desalinated to obtain fresh water. Solar energy is used in some cases for desalination. An alternative is to freeze the seawater. The ice thus formed will be relatively free of salt. The ice can be separated and thawed to obtain fresh water.

3.4.6. *Ice Manufacture:* This was the classical application of refrigeration. Ice was manufactured in plants by dipping water containers in chilled brine and it used to take about 36 hours to freeze all the water in cans into ice. The ice thus formed was stored in

ice warehouses. Now that small freezers and [icemakers](#) are available. Hotels and restaurants make their own ice, in a hygienic manner. Household refrigerators also have the facility to make ice in small quantities. The use of ice warehouses is dwindling because of this reason. Coastal areas still have ice plants where it is used for transport of iced fish.

Refrigeration systems are also required in remote and rural areas for a wide variety of applications such as storage of milk, vegetables, fruits, foodgrains etc., and also for storage of vaccines etc. in health centers. One typical problem with many of the rural and remote areas is the continuous availability of electricity. Since space is not constraint, and most of these areas in tropical countries are blessed with alternate energy sources such as solar energy, biomass etc., it is preferable to use these clean and renewable energy sources in these areas. Thermal energy driven absorption systems have been used in some instances. Vapour compression systems that run on photovoltaic (PV) cells have also been developed for small applications. Figure 3.5 shows the schematic of solar PV cell driven vapour compression refrigeration system for vaccine storage.



*Fig.3.5. Solar energy driven refrigeration system for vaccine storage*

**Q.** Refrigeration is required in petrochemical industries to:

- a) Separate gases by fractional distillation
- b) Provide safe environment
- c) Carry out chemical reactions
- d) All of the above

**Ans.:** a)

**Q.** Cold treatment of metals is carried out to:

- a) To stabilize precision parts
- b) To improve hardness and wear resistance
- c) To improve ductility
- d) To improve life of cutting tools
- e) All of the above

**Ans.:** e)

**Q.** Refrigeration is used in construction of dams etc to:

- a) Avoid crack development during setting of concrete
- b) Avoid water evaporation
- c) Reduce cost of construction
- d) All of the above

**Ans.:** a)

**Q.** Refrigeration is required in remote and rural areas to:

- a) Store fresh and farm produce
- b) Store vaccines in primary health centres
- c) Store milk before it is transported to dairy plants
- d) All of the above

**Ans.:** d)

**Q.** Compared to urban areas, in rural areas:

- a) Continuous availability of grid electricity is not ensured
- b) Space is not a constraint
- c) Refrigeration is not really required
- d) Refrigeration systems cannot be maintained properly

**Ans.:** a) and b)



### 3.5 Application of air conditioning:

Air-conditioning is required for improving processes and materials apart from comfort air-conditioning required for comfort of persons. The life and efficiency of electronic devices increases at lower temperatures. Computer and microprocessor-based equipment also require air-conditioning for their efficient operation. Modern electronic equipment with Very Large Scale Integrated (VLSI) chips dissipates relatively large quantities of energy in a small volume. As a result, unless suitable cooling is provided, the chip temperature can become extremely high. As the computing power of computers increases, more and more cooling will be required in a small volume. Some supercomputers required liquid nitrogen for cooling.

Air-conditioning applications can be divided into two categories, namely, industrial and comfort air-conditioning.

**3.5.1. Industrial Air-conditioning:** The main purpose of industrial air conditioning systems is to provide conducive conditions so that the required processes can be carried out and required products can be produced. Of course, the industrial air conditioning systems must also provide at least a partial measure of comfort to the people working in the industries. The applications are very diverse, involving cooling of laboratories down to  $-40^{\circ}\text{C}$  for engine testing to cooling of farm animals. The following are the applications to name a few.

Laboratories: This may involve precision measurement to performance testing of materials, equipment and processes at controlled temperature and relative humidity. Laboratories carrying out research in electronics and biotechnology areas require very clean atmosphere. Many laboratories using high voltage like in LASERS require very low humidity to avoid the sparking.

Printing: Some colour printing presses have one press for each colour. The paper passes from one press to another press. The ink of one colour must get dried before it reaches the second press, so that the colours do not smudge. And the paper should not shrink, so that the picture does not get distorted. This requires control over temperature as well humidity. Improper humidity may cause static electricity, curling and buckling of paper.

Manufacture of Precision Parts: If the metal parts are maintained at uniform temperature during manufacturing process, these will neither expand nor shrink, maintaining close tolerances. A lower relative humidity will prevent rust formation also. A speck of dust in a switch or relay can cause total or partial malfunction in spacecraft. The manufacture of VLSI chips, microprocessors, computers, aircraft parts, Micro-Electro Mechanical Systems (MEMS), nanomaterial fabrication and many areas of modern progress require a very clean atmosphere and proper control over humidity. Any impurity in the atmosphere will spoil the VLSI chips. The concept of Clean rooms has been introduced for such industries. In fact, all precision industries that use microprocessors require these clean rooms.

Textile Industry: The yarn in the textile industry is spun and it moves over spools at very high speeds in modern machines. It is very sensitive to humidity. The generation of static electricity should be avoided. Its flexibility and strength should not change. If it breaks during the process, the plant will have to be stopped and yarn repaired before restarting the plant.

Pharmaceutical Industries: In these industries to obtain sterile atmosphere, the airborne bacteria and dust must be removed in the air-conditioning system by filters. These industries require clean rooms. If capsules are made or used in the plant, then air has to be dry otherwise the gelatin of capsules will become sticky.

Photographic Material: The raw material used for filmmaking has to be maintained at low temperature, since it deteriorates at high temperature and humidity. The film also has to be stored at low temperature. The room where film is developed requires 100% replacement by fresh air of the air polluted by chemicals.

Farm Animals: The yield of Jersey cows decreases drastically during summer months. Low temperature results in more efficient digestion of food and increase in weight of cow and the milk yield. Animal barns have to be ventilated in any case since their number density is usually very large. In many countries evaporative cooling is used for creating comfort conditions in animal houses.

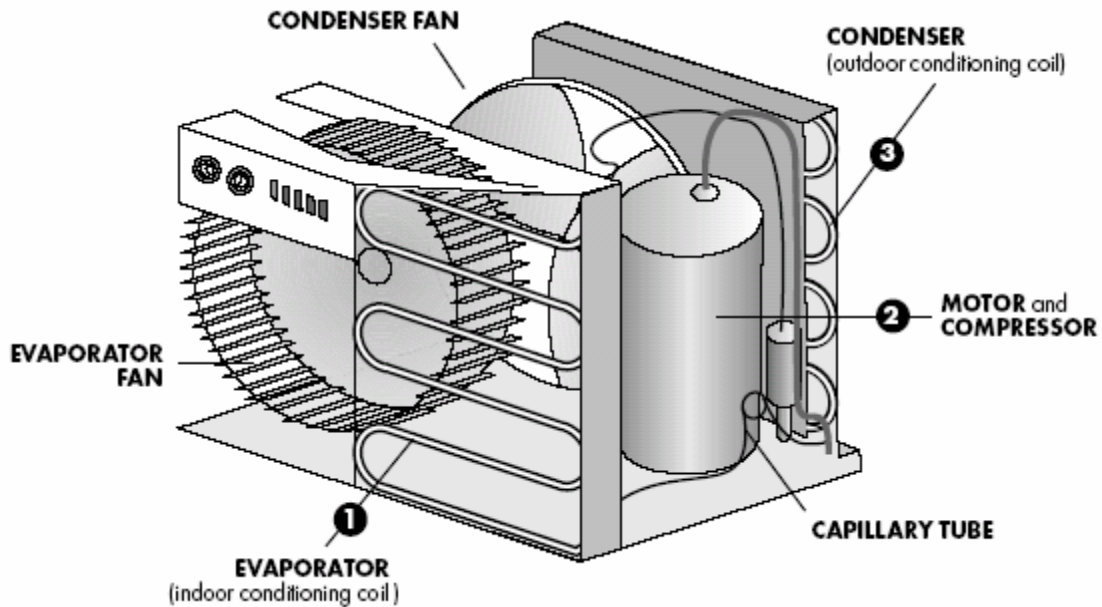
Computer Rooms: These require control of temperature, humidity and cleanliness. The temperature of around 25 °C and relative humidity of 50% is maintained in these rooms. The dust spoils the CD drives and printers etc.; hence the rooms have to be kept clean also by using micro filters in the air-conditioning system.

Power Plants: Most of the modern power plants are microprocessor controlled. In the earlier designs, the control rooms were very large and were provided with natural ventilation. These days the control rooms are very compact, hence these require air-conditioning for persons and the microprocessors.

Vehicular Air-conditioning: Bus, tram, truck, car, recreational vehicle, crane cabin, aircraft and ships all require air-conditioning. In bus, tram, aircraft and ship, the occupancy density is very high and the metabolic heat and water vapour generated by persons has to be rejected. The cooling load in these is very high and rapidly changes that provides a challenge for their design.

**3.5.2. Comfort Air-Conditioning:** Energy of food is converted into chemical energy for functioning of brain, lungs, heart and other organs and this energy is ultimately rejected to the surroundings. Also the internal organs require a temperature close to 35°C for their efficient operation, and regulatory mechanisms of human body maintain this temperature by rejecting appropriate amount of heat. Human beings do not feel comfortable if some extra effort is required by the body to reject this energy. The air temperature, humidity and velocity at which human body does not have to take any extra action, is called comfort condition. Comfort condition is also sometimes called as neutral condition.

The residences, offices, shopping centers, stores, large buildings, theatres, auditorium etc. all have slightly different requirements and require different design. The required cooling capacities also vary widely depending upon the application. The factory assembled room air conditioners are very widely used for small residences, offices etc. These units are available as window type or split type. The capacity of these systems vary from a fraction of a ton (TR) to about 2 TR. These systems use a vapour compression refrigeration system with a sealed compressor and forced convection type evaporators and condensers. Figure 3.6 shows the schematic of a widow type room air conditioner. In this type all the components are housed in a single outer casing. In a split type air conditioner, the compressor and condenser with fan (commonly known as condensing unit) are housed in a separate casing and is kept away from the indoor unit consisting of the evaporator, blower, filter etc. The outdoor and indoor units are connected by refrigerant piping. For medium sized buildings factory assembled package units are



*Fig.3.6. Schematic of window type room air conditioner*

available, while for very large buildings a central air conditioning system is used.

Hospitals require sterile atmosphere so that bacteria emitted by one patient does not affect the other persons. This is specially so for the operation theatres and intensive care units. In these places no part of the room air is re-circulated after conditioning by A/C system. In other places up to 90% of the cold room air is re-circulated and 10% outdoor fresh air is taken to meet the ventilation requirement of persons. In hospitals all the room air is thrown out and 100% fresh air is taken into the A/C system. Since, outdoor air may be at 45°C compared to 25°C of the room air, the air-conditioning load becomes very large. The humidity load also increases on this account. Operation theaters require special attention in prevention of spores, viruses, bacteria and contaminants given

off by various devices and materials. Special quality construction and filters are used for this purpose.

Restaurants, theatres and other places of amusement require air-conditioning for the comfort of patrons. All places where, a large number of people assemble should have sufficient supply of fresh air to dilute CO<sub>2</sub> and body odours emitted by persons. In addition, people dissipate large quantities of heat that has to be removed by air-conditioning for the comfort of persons. These places have wide variation in air-conditioning load throughout the day. These have large number of persons, which add a lot of water vapour by respiration and perspiration. The food cooked and consumed also adds water vapour. This vapour has to be removed by air-conditioning plant. Hence, these buildings have large latent heat loads. Infiltration of warm outdoor is also large since the large number of persons enter and leave the building leading to entry of outdoor air with every door opening. Ventilation requirement is also very large.

Air-conditioning in stores and supermarkets attracts more customers, induces longer period of stay and thereby increases the sales. Supermarkets have frozen food section, refrigerated food section, dairy and brewage section, all of them requiring different temperatures. The refrigeration system has to cater to different temperatures, apart from air-conditioning. These places also have a wide variation in daily loads depending upon busy and lean hours, and holidays.

Large commercial buildings are a world of their own; they have their own shopping center, recreation center, gymnasium swimming pool etc. Offices have very high density of persons during office hours and no occupancy during off time. These buildings require integrated concept with optimum utilization of resources and services. These have security aspects, fire protection, emergency services, optimum utilization of energy all built-in. Modern buildings of this type are called intelligent buildings where air-conditioning requires large amount of energy and hence is the major focus.

Since persons have to spend a major part of their time within the building, without much exposure to outdoors, the concept of Indoor Air Quality (IAQ) has become very important. There are a large number of pollutants that are emitted by the materials used in the construction of buildings and brought into the buildings. IAQ addresses to these issues and gives recommendation for their reduction to safe limits. Sick building syndrome is very common in poorly designed air conditioned buildings due to inadequate ventilation and use of improper materials. The sick building syndrome is characterized by the feeling of nausea, headache, eye and throat irritation and the general feeling of being uncomfortable with the indoor environment. In developed countries this is leading to litigation also.

In the earlier systems little attention was paid to energy conservation, since fuels were abundant and inexpensive. The energy crisis in early seventies, lead to a review of basic principles and increased interest in energy optimization. The concept of low initial cost with no regard to operating cost has become obsolete now. Approaches, concepts and thermodynamic cycles, which were considered impractical at one time, are receiving

serious considerations now. Earlier, the index of performance used to be [first law efficiency](#), now in addition to that; the [second law efficiency](#) is considered so that the available energy utilized and wasted can be clearly seen. Concepts of hybrid cycles, heat recovery systems, alternate refrigerants and mixtures of refrigerants are being proposed to optimize energy use. Large-scale applications of air-conditioning in vast office and industrial complexes and increased awareness of comfort and indoor air quality have lead to challenges in system design and simulations. Developments in electronics, controls and computers have made refrigeration and air-conditioning a high-technology industry.

**Q.** Air conditioning involves:

- a) Control of temperature
- b) Control of humidity
- c) Control of air motion
- d) Control of air purity
- e) All of the above

**Ans.:** e)

**Q.** The purpose of industrial air conditioning is to:

- a) Provide suitable conditions for products and processes
- b) Provide at least a partial measure of comfort to workers
- c) Reduce energy consumption
- d) All of the above

**Ans.:** a) and b)

**Q.** Air conditioning is required in the manufacture of precision parts to:

- a) Achieve close tolerances
- b) Prevent rust formation
- c) Provide clean environment
- d) All of the above

**Ans.:** d)

**Q.** Modern electronic equipment require cooling due to:

- a) Dissipation of relatively large amount of heat in small volumes
- b) To prevent erratic behaviour
- c) To improve life
- d) All of the above

**Ans.:** d)

**Q.** Human beings need air conditioning as:

- a) They continuously dissipate heat due to metabolic activity
- b) Body regulatory mechanisms need stable internal temperatures
- c) Efficiency improves under controlled conditions
- d) All of the above

**Ans.:** d)

**Q.** Small residences and offices use:

- a) Window air conditioners
- b) Split air conditioners
- c) Central air conditioning
- d) All of the above

**Ans.:** a) and b)

### 3.6. Conclusions:

The scope of refrigeration is very wide and applications are very diverse and literally thousands of scientists and engineers have contributed towards its development. The accomplishments of these unnamed persons are summarized in the ASHRAE Handbooks. The principles presented in this text follow the information provided in these handbooks.

**Q.** What do you understand by a cold chain for food products?

**Ans.:** Proper food preservation requires the maintenance of a cold chain beginning from the place of harvest and ending at the place of consumption. A typical cold chain consists of facilities for pre-treatment at the place of harvest, refrigeration/freezing at food processing plant, refrigeration during transit, storage in refrigerated warehouses (cold storages), refrigerated displays at the market, and finally storage in the domestic freezer/refrigerator. It is very important that suitable conditions be provided for the perishable products through out the chain.

**Q.** Explain the importance of cold storages

**Ans.:** Preservation of perishable products using cold storages equalizes the prices throughout the year and makes these products available round the year. Without them, the prices would be very low at the time of harvest and very high during the off-season. With storage facilities, it would also be possible to make the products available in areas where they are not grown.

**Q.** What are the important issues to be considered in the design of refrigeration systems?

**Ans.:** Refrigeration systems are used in a wide variety of applications. Each application has specific requirements of temperature, moisture content, capacity, operating duration, availability of resources etc. Hence, refrigeration system design must be done for each application based on the specific requirements. Since refrigeration systems are cost and energy intensive, it is important to design the systems to achieve low initial and running costs. Reliability of the systems is also very important as the failure of the refrigeration systems to perform may lead huge financial losses. Of late, issues related to environment have attracted great attention, hence the refrigeration systems should be as far as possible environment friendly.

**Q.** What is the relation between refrigeration and air conditioning?

**Ans.** Air conditioning involves control of temperature and moisture content. One of the most common requirement of air conditioning systems is cooling and dehumidification of air. Refrigeration systems are required for cooling and dehumidification. Refrigeration systems can also be used for heating of air by utilizing the heat rejected at the condenser, i.e., by running them as heat pumps.

**Q.** What is meant by IAQ and what does it involve?

**Ans.:** IAQ stands for Indoor Air Quality and it refers to the ways and means of reducing and maintaining the pollutants inside the occupied space within tolerable levels. IAQ involves specifying suitable levels of fresh air supply (ventilation), suitable air filters, use of proper materials of construction, furniture, carpets, draperies etc.

# Lesson

4

Review of fundamental  
principles –  
Thermodynamics : Part I



The main objective of this lesson and the subsequent lesson is to review fundamental principles of thermodynamics pertinent to refrigeration and air conditioning. The specific objectives of this part are to:

1. Introduce and define important thermodynamic concepts such as thermodynamic system, path and point functions, thermodynamic process, cycle, heat, work etc. (*Sections 4.2 and 4.3*)
2. State the four fundamental laws of thermodynamics (*Section 4.4*)
3. Apply first law of thermodynamics to closed and open systems and develop relevant equations (*Section 4.4*)
4. Introduce and define thermodynamic properties such as internal energy and enthalpy (*Section 4.4*)
5. Discuss the importance of second law of thermodynamics and state Carnot theorems (*Section 4.4*)
6. Define and distinguish the differences between heat engine, refrigerator and heat pump (*Section 4.4*)
7. Obtain expressions for Carnot efficiency of heat engine, refrigerator and heat pump (*Section 4.4*)
8. State Clausius inequality and introduce the property 'entropy' (*Section 4.4*)

At the end of the lesson the student should be able to:

1. Identify path function and point functions
2. Define heat and work
3. Apply first law of thermodynamics to open and closed systems
4. State second law of thermodynamics
5. Define heat engine, refrigerator and heat pump
6. Apply second law of thermodynamics to evaluate efficiencies of reversible cycles
7. State Clausius inequality and define entropy
8. Define reversible and irreversible processes
9. State the principle of increase of entropy

## 4.1. Introduction

Refrigeration and air conditioning involves various processes such as compression, expansion, cooling, heating, humidification, de-humidification, air purification, air distribution etc. In all these processes, there is an exchange of mass, momentum and energy. All these exchanges are subject to certain fundamental laws. Hence to understand and analyse refrigeration and air conditioning systems, a basic knowledge of the laws of thermodynamics, fluid mechanics and heat transfer that govern these processes is essential. It is assumed that the reader has studied courses in engineering thermodynamics, fluid mechanics and heat transfer. This chapter reviews some of the fundamental concepts of thermodynamics pertinent to refrigeration and air-conditioning.

## 4.2. Definitions

*Thermodynamics* is the study of energy interactions between *systems* and the effect of these interactions on the system *properties*. Energy transfer between systems takes place in the form of *heat and/or work*. Thermodynamics deals with [systems in equilibrium](#).

A *thermodynamic system* is defined as a quantity of matter of fixed mass and identity upon which attention is focused for study. In simple terms, a system is whatever we want to study. A system could be as simple as a gas in a cylinder or as complex as a nuclear power plant. Everything external to the system is the *surroundings*. The system is separated from the surroundings by the *system boundaries*. Thermodynamic systems can be further classified into [closed systems, open systems and isolated systems](#).

A *control volume*, which may be considered as an open system, is defined as a specified region in space upon which attention is focused. The control volume is separated from the surroundings by a *control surface*. Both mass and energy can enter or leave the control volume.

The first and an extremely important step in the study of thermodynamics is to choose and identify the system properly and show the system boundaries clearly.

A *process* is defined as the path of thermodynamic states which the system passes through as it goes from an initial state to a final state. In refrigeration and air conditioning one encounters a wide variety of processes. Understanding the nature of the process path is very important as heat and work depend on the path.

A system is said to have undergone a *cycle* if beginning with an initial state it goes through different processes and finally arrives at the initial state.

### 4.2.1. Heat and work:

*Heat* is energy transferred between a system and its surroundings by virtue of a temperature difference only. The different modes of heat transfer are: conduction, convection and radiation.

*Heat* is a way of changing the energy of a system by virtue of a temperature difference only. Any other means for changing the energy of a system is called *work*. We can have push-pull work (*e.g.* in a piston-cylinder, lifting a weight), electric and magnetic work (*e.g.* an electric motor), chemical work, surface tension work, elastic work, *etc.*

**Mechanical modes of work:** In mechanics work is said to be done when a force 'F' moves through a distance 'dx'. When this force is a mechanical force, we call the work done as a mechanical mode of work. The classical examples of mechanical mode of work are:

1. Moving system boundary work
2. Rotating shaft work
3. Elastic work, and
4. Surface tension work

For a moving system boundary work, the work done during a process 1-2 is given by:

$${}_1W_2 = \int_1^2 p.dV \quad (4.1)$$

where 'p' is the pressure acting on the system boundary and 'dV' is the differential volume. It is assumed that the process is carried out very slowly so that at each instant of time the system is in equilibrium. Typically such a process is called a quasi-equilibrium process.

For rigid containers, volume is constant, hence moving boundary work is zero in this case. For other systems, in order to find the work done one needs to know the relation between pressure p and volume V during the process.

**Sign convention for work and heat transfer:** Most thermodynamics books consider the work done by the system to be positive and the work done on the system to be negative. The heat transfer to the system is considered to be positive and heat rejected by the system is considered to be negative. The same convention is followed throughout this course.

#### 4.2.2. Thermodynamic Functions:

There are two types of functions defined in thermodynamics, path function and point function.

*Path function* depends on history of the system (or path by which system arrived at a given state). Examples for path functions are work and heat. *Point function* does not depend on the history (or path) of the system. It only depends on the state of the system. Examples of point functions are: temperature, pressure, density, mass, volume, enthalpy, entropy, internal energy etc. Path functions are not properties of the system, while point functions are properties of the system. Change in point function can be obtained by from the initial and final values of the function, whereas path has to defined in order to evaluate path functions. Figure 4.1 shows the difference between point and path functions. Processes A and B have same initial and final states, hence, the change in volume ( $DV_A$  and  $DV_B$ ) for both these processes is same ( $3 \text{ m}^3$ ), as volume is a point function, whereas the work transferred ( $W_A$  and  $W_B$ ) for the processes is different since work is a path function. It should also be noted that the cyclic integrals of all point functions is zero, while the cyclic integrals of path functions may be or may not be zero.

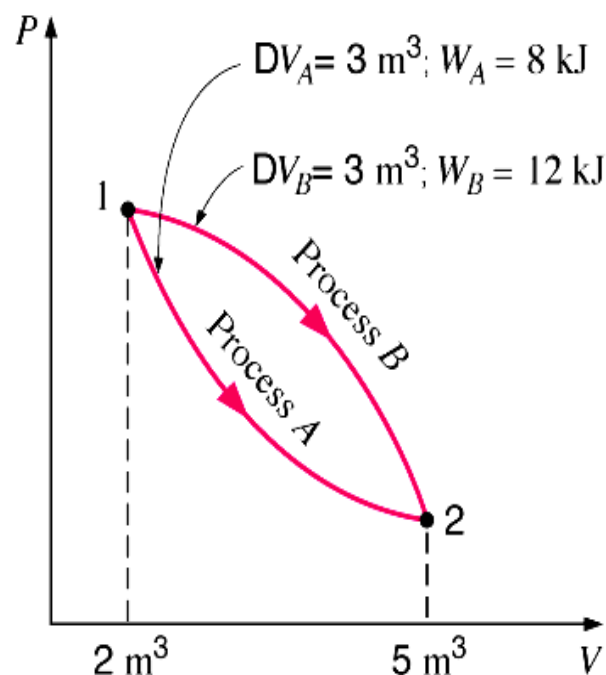


Fig. 4.1. Difference between point and path functions

### 4.3. Thermodynamic properties

A system is specified and analyzed in terms of its *properties*. A property is any characteristic or attribute of matter, which can be evaluated quantitatively. The amount of energy transferred in a given process, work done, energy stored etc. are all evaluated in terms of the changes of the system properties.

A *thermodynamic property* depends only on the state of the system and is independent of the path by which the system arrived at the given state. Hence all thermodynamic properties are point functions. Thermodynamic properties can be either intensive (independent of size/mass, e.g. temperature, pressure, density) or extensive (dependent on size/mass, e.g. mass, volume)

Thermodynamic properties relevant to refrigeration and air conditioning systems are temperature, pressure, volume, density, specific heat, enthalpy, entropy etc.

It is to be noted that heat and work are not properties of a system.

Some of the properties, with which we are already familiar, are: temperature, pressure, density, specific volume, specific heat etc. Thermodynamics introduces certain new properties such as internal energy, enthalpy, entropy etc. These properties will be described in due course.

#### 4.3.1. State postulate:

This postulate states that the number of independent intensive thermodynamic properties required to specify the state of a closed system that is:

- a) Subject to conditions of local equilibrium
- b) Exposed to 'n' different (non-chemical) work modes of energy transport, and
- c) Composed of 'm' different pure substances

is  $(n+m)$ . For a pure substance ( $m = 1$ ) subjected to only one work mode ( $n = 1$ ) two independent intensive properties are required to fix the state of the system completely ( $n + m = 2$ ). Such a system is called a *simple system*. A pure gas or vapour under compression or expansion is an example of a simple system. Here the work mode is moving system boundary work.

### 4.4. Fundamental laws of Thermodynamics

Classical thermodynamics is based upon four empirical principles called zeroth, first, second and third laws of thermodynamics. These laws define thermodynamic properties, which are of great importance in understanding of thermodynamic principles. Zeroth law defines temperature; first law defines internal energy; second law defines entropy and the third law can be used to obtain absolute entropy values. The above four thermodynamic laws are based on human observation of natural phenomena; they are not mathematically derived equations. Since no exceptions to these have been observed; these are accepted as laws.

*Conservation of mass* is a fundamental concept, which states that mass is neither created nor destroyed.

The *Zeroth law of thermodynamics* states that when two systems are in thermal equilibrium with a third system, then they in turn are in thermal equilibrium with each other. This implies that

some property must be same for the three systems. This property is temperature. Thus this law is the basis for temperature measurement. Equality of temperature is a necessary and sufficient condition for thermal equilibrium, *i.e.* no transfer of heat.

The *First law of thermodynamics* is a statement of law of conservation of energy. Also, according to this law, heat and work are interchangeable. Any system that violates the first law (*i.e.*, creates or destroys energy) is known as a Perpetual Motion Machine (PMM) of first kind. For a system undergoing a cyclic process, the first law of thermodynamics is given by:

$$\oint \delta Q = \oint \delta W \quad (4.2)$$

where  $\oint \delta Q$  = net heat transfer during the cycle

$\oint \delta W$  = net work transfer during the cycle

Equation (4.2) can be written as:

$$\oint (\delta Q - \delta W) = 0 \quad (4.3)$$

This implies that  $(\delta Q - \delta W)$  must be a point function or property of the system. This property is termed as *internal energy*,  $U$ . Mathematically, internal energy can be written as:

$$dU = \delta Q - \delta W \quad (4.4)$$

The internal energy of a system represents a sum total of all forms of energy viz. thermal, molecular, lattice, nuclear, rotational, vibrational etc.

#### 4.4.1. First law of thermodynamics for a closed system:

Let the internal energy of a closed system at an equilibrium state 1 be  $U_1$ . If  ${}_1Q_2$  amount of heat is transferred across its boundary and  ${}_1W_2$  is the amount of work done by the system and the system is allowed to come to an equilibrium state 2. Then integration of Eqn. (4.4) yields,

$$U_2 - U_1 = {}_1Q_2 - {}_1W_2 \quad (4.5)$$

If  $m$  is the mass of the system and  $u$  denotes the specific internal energy of the system then,

$$m(u_2 - u_1) = m({}_1q_2 - {}_1w_2) \quad (4.6)$$

$$\text{or, } u_2 - u_1 = {}_1q_2 - {}_1w_2 \quad (4.7)$$

where,  ${}_1q_2$  and  ${}_1w_2$  are heat transfer and work done per unit mass of the system.

#### Flow Work:

In an open system some matter, usually fluid enters and leaves the system. It requires flow work for the fluid to enter the system against the system pressure and at the same time flow work is required to expel the fluid from the system. It can be shown that the specific flow work is given by the product of pressure,  $p$  and specific volume,  $v$ , *i.e.*, flow work =  $pv$ .

### Enthalpy:

In the analysis of open systems, it is convenient to combine the specific flow work ' $pv$ ' with internal energy ' $u$ ' as both of them increase the energy of the system. The sum of specific internal energy and specific flow work is an intensive property of the system and is called specific enthalpy,  $h$ . Thus specific enthalpy,  $h$  is given by:

$$h = u + pv \quad (4.8)$$

#### 4.4.2. First law of thermodynamics for open system:

For an open system shown in Figure 4.2,  $m_1$  and  $m_2$  are the mass flow rates at inlet and outlet,  $h_1$  and  $h_2$  are the specific enthalpies at inlet and outlet,  $V_1$  and  $V_2$  are the inlet and outlet velocities and  $z_1$  and  $z_2$  are the heights at inlet and outlet with reference to a datum;  $q$  and  $w$  are the rate of heat and work transfer to the system and  $E$  is the total energy of the system.

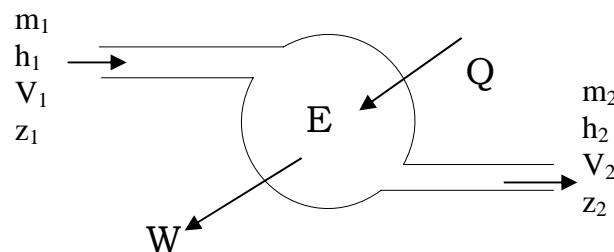


Fig. 4.2. First law of thermodynamics for an open system

Then the first law for this open system is given by:

$$\frac{dE}{dt} = m_2 \left( h_2 + \frac{V_2^2}{2} + gz_2 \right) - m_1 \left( h_1 + \frac{V_1^2}{2} + gz_1 \right) + W - Q \quad (4.9)$$

where  $(dE/dt)$  is the rate at which the total energy of the system changes and ' $g$ ' is the acceleration due to gravity.

#### First law for open system in steady state

In steady state process, the time rate of change of all the quantities is zero, and mass is also conserved. As a result, the mass and total energy of the system do not change with time, hence,  $(dE/dt)$  is zero and from conservation of mass,  $m_1 = m_2 = m$ . Then the first law becomes:

$$\left( h_2 + \frac{V_2^2}{2} + gz_2 \right) - \left( h_1 + \frac{V_1^2}{2} + gz_1 \right) = \dot{q} - \dot{w} \quad (4.10)$$

where  $\dot{q}$  and  $\dot{w}$  are specific heat and work transfer rates

## **Second law of thermodynamics:**

The second law of thermodynamics is a limit law. It gives the upper limit of efficiency of a system. The second law also acknowledges that processes follow in a certain direction but not in the opposite direction. It also defines the important property called entropy.

It is common sense that heat will not flow spontaneously from a body at lower temperature to a body at higher temperature. In order to transfer heat from lower temperature to higher temperature continuously (that is, to maintain the low temperature) a refrigeration system is needed which requires work input from external source. This is one of the principles of second law of thermodynamics, which is known as *Clausius statement of the second law*.

### **Clausius' statement of second law**

*It is impossible to transfer heat in a cyclic process from low temperature to high temperature without work from external source.*

It is also a fact that all the energy supplied to a system as work can be dissipated as heat transfer. On the other hand, all the energy supplied as heat transfer cannot be continuously converted into work giving a thermal efficiency of 100 percent. Only a part of heat transfer at high temperature in a cyclic process can be converted into work, the remaining part has to be rejected to surroundings at lower temperature. If it were possible to obtain work continuously by heat transfer with a single heat source, then automobile will run by deriving energy from atmosphere at no cost. A hypothetical machine that can achieve it is called Perpetual Motion Machine of second kind. This fact is embedded in *Kelvin-Planck Statement of the Second law*.

### **Kelvin-Planck statement of second law**

*It is impossible to construct a device (engine) operating in a cycle that will produce no effect other than extraction of heat from a single reservoir and convert all of it into work.*

Mathematically, Kelvin-Planck statement can be written as:

$$W_{\text{cycle}} \leq 0 \text{ (for a single reservoir)} \quad (4.11)$$

### **Reversible and Irreversible Processes**

*A process is reversible with respect to the system and surroundings if the system and the surroundings can be restored to their respective initial states by reversing the direction of the process, that is, by reversing the heat transfer and work transfer. The process is irreversible if it cannot fulfill this criterion.*

If work is done in presence of friction, say by movement of piston in a cylinder then a part of the work is dissipated as heat and it cannot be fully recovered if the direction of process is reversed. Similarly, if heat is transferred through a temperature difference from higher temperature to a lower temperature, its direction cannot be reversed since heat transfer from lower temperature to higher temperature would require external work input. These are two examples of irreversible processes.

Reversible process is a hypothetical process in which work is done in absence of friction and heat transfer occurs isothermally. Irreversibility leads to loss in work output and loss in availability and useful work.

#### **4.4.3. Heat engines, Refrigerators, Heat pumps:**

A heat engine may be defined as a device that operates in a thermodynamic cycle and does a certain amount of net positive work through the transfer of heat from a high temperature body to a low temperature body. A steam power plant is an example of a heat engine.

A refrigerator may be defined as a device that operates in a thermodynamic cycle and transfers a certain amount of heat from a body at a lower temperature to a body at a higher temperature by consuming certain amount of external work. Domestic refrigerators and room air conditioners are the examples. In a refrigerator, the required output is the heat extracted from the low temperature body.

A heat pump is similar to a refrigerator, however, here the required output is the heat rejected to the high temperature body.

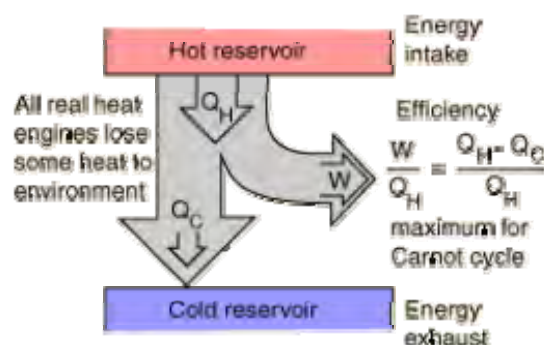
#### **Carnot's theorems for heat engines:**

Theorem 1: *It is impossible to construct a heat engine that operates between two [thermal reservoirs](#) and is more efficient than a reversible engine operating between the same two reservoirs.*

Theorem 2: *All reversible heat engines operating between the same two thermal reservoirs have the same thermal efficiency.*

The two theorems can be proved by carrying out a thought experiment and with the help of second law. Carnot's theorems can also be formed for refrigerators in a manner similar to heat engines.

Carnot efficiency: The Carnot efficiencies are the efficiencies of completely reversible cycles operating between two thermal reservoirs. According to Carnot's theorems, for any given two thermal reservoirs, the Carnot efficiency represents the maximum possible efficiency.





Thermal efficiency for a heat engine,  $\eta_{HE}$  is defined as:

$$\eta_{HE} = \frac{W_{cycle}}{Q_H} = 1 - \frac{Q_C}{Q_H} \quad (4.12)$$

where  $W_{cycle}$  is the net work output,  $Q_C$  and  $Q_H$  and are the heat rejected to the low temperature reservoir and heat added (heat input) from the high temperature reservoir, respectively.

It follows from Carnot's theorems that for a reversible cycle ( $\frac{Q_C}{Q_H}$ ) is a function of temperatures

of the two reservoirs only. i.e.  $\frac{Q_C}{Q_H} = \phi(T_C, T_H)$ .

If we choose the absolute (*Kelvin*) temperature scale then:

$$\frac{Q_C}{Q_H} = \frac{T_C}{T_H} \quad (4.13)$$

$$\text{hence, } \eta_{Carnot,HE} = 1 - \frac{Q_C}{Q_H} = 1 - \frac{T_C}{T_H} \quad (4.14)$$

The efficiency of refrigerator and heat pump is called as Coefficient of Performance (COP). Similarly to heat engines, Carnot coefficient of performance for heat pump and refrigerators  $COP_{HP}$  and  $COP_R$  can be written as

$$\begin{aligned} COP_{Carnot,HP} &= \frac{Q_H}{W_{cycle}} = \frac{Q_H}{Q_H - Q_C} = \frac{T_H}{T_H - T_C} \\ COP_{Carnot,R} &= \frac{Q_C}{W_{cycle}} = \frac{Q_C}{Q_H - Q_C} = \frac{T_C}{T_H - T_C} \end{aligned} \quad (4.15)$$

where

$W_{cycle}$  = work input to the reversible heat pump and refrigerator

$Q_H$  = heat transferred between the system and the hot reservoir

$Q_C$  = heat transferred between the system and cold reservoir

$T_H$  = temperature of the hot reservoir

$T_C$  = temperature of the cold reservoir

### **Clausius inequality:**

The Clausius inequality is a mathematical form of second law of thermodynamics for a closed system undergoing a cyclic process. It is given by:

$$\oint_b \left( \frac{\delta Q}{T} \right) \leq 0 \quad (4.16)$$

In the above equation (4.16),  $\delta Q$  represents the heat transfer at a part of the system boundary during a portion of the cycle, and  $T$  is the absolute temperature at that part of the boundary. The subscript "b" serves as a reminder that the integrand is evaluated at the boundary of the system executing the cycle. The equality applies when there are no internal irreversibilities as the

system executes the cycle, and inequality applies when there are internal irreversibilities are present.

### Entropy:

As mentioned before, second law of thermodynamics introduces the property, entropy. It is a measure of amount of disorder in a system. It is also a measure of the extent to which the energy of a system is unavailable. From Clausius inequality,  $\oint \left( \frac{\delta Q}{T} \right)_{b,rev} = 0$  for a reversible cycle. This

implies that the quantity  $\left( \frac{\delta Q}{T} \right)_{b,rev}$  must be a point function, hence a property of the system. This property is named as ‘entropy’ by Clausius. The entropy change between any two equilibrium states 1 and 2 of a system is given by:

$$S_2 - S_1 = \left( \int_1^2 \frac{\delta Q}{T} \right)_{int, rev} \quad (4.17)$$

Where  $S_2$ ,  $S_1$  are the entropies at states 1 and 2. The subscript “int rev” is added as a reminder that the integration is carried out for any internally reversible process between the two states.

In general, for any process 1-2, the entropy change can be written as:

$$S_2 - S_1 \geq \left( \int_1^2 \frac{\delta Q}{T} \right)_b \quad (4.18)$$

The equality applies when there are no internal irreversibilities as the system executes the cycle, and inequality applies when there are internal irreversibilities are present.

Equation (4.18) can also be written as:

$$S_2 - S_1 = \left( \int_1^2 \frac{\delta Q}{T} \right)_b + \sigma \quad (4.19)$$

$$\text{where } \sigma : \begin{cases} > 0 & \text{irreversibilities present within the system} \\ = 0 & \text{no irreversibilities present within in the system} \end{cases}$$

The above equation may be considered as an entropy balance equation for a closed system. If the end states are fixed, the entropy change on the left side of Eqn. (4.19) can be evaluated independently of the details of the process. The two terms on the right side depend explicitly on the nature of the process and cannot be determines solely from the knowledge of end states. The first term on the right side of the equation is interpreted as entropy transfer. The direction of entropy transfer is same as that of heat transfer. The entropy change of a system is not accounted solely by the entropy transfer. We have to include another term for entropy generation due to internal irreversibilities in the system. The second term in Eqn. (4.19) accounts for this, and is interpreted as entropy production. The value of entropy production cannot be negative. It can

have either zero or positive value. But the change in entropy of the system can be positive, negative, or zero.

$$S_2 - S_1 : \begin{cases} > 0 \\ = 0 \\ < 0 \end{cases} \quad (4.20)$$

### Principle of increase of entropy:

According the definition of an isolated system one can write:

$$\Delta E_{isol} = 0 \quad (4.21)$$

because no energy transfers takes place across its boundary. Thus the energy of the isolated system remains constant.

An entropy balance for an isolated energy is written as:

$$\Delta S_{isol} = \left( \int_1^2 \frac{\delta Q}{T} \right)_b + \sigma_{isol} \quad (4.22)$$

Since there are there are no energy transfers in an isolated system, the first term in the above equation is zero, hence the above equation reduces to:

$$\Delta S_{isol} = \sigma_{isol} > 0 \quad (4.23)$$

where  $\sigma_{isol}$  is the total amount of entropy produced within the isolated system, since this cannot be negative, it implies that the entropy of an isolated system can only increase. If we consider a combined system that includes the system and its surroundings, then the combined system becomes an isolated system. Then one can write:

$$\Delta S_{system} + \Delta S_{surroundings} = \sigma_{isol} > 0 \quad (4.24)$$

since entropy is produced in all actual processes, only processes that can occur are those for which the entropy of the isolated system increases. Energy of an isolated system is conserved whereas entropy of an isolated system increases. This is called the principle of increase of entropy.

### **Third law of thermodynamics:**

This law gives the definition of absolute value of entropy and also states that absolute zero cannot be achieved. Another version of this law is that “the entropy of perfect crystals is zero at absolute zero”. This statement is attributed to Plank. This is in line with the concept that entropy is a measure of disorder of the system. If ‘ $\omega$ ’ is the probability of achieving a particular state out of a large number of states; then entropy of the system is equal to  $\ln(\omega)$ . The transitional movement of molecules ceases at absolute zero and position of atoms can be uniquely specified. In addition, if we have a perfect crystal, then all of its atoms are alike and their positions can be

interchanged without changing the state. The probability of this state is unity, that is  $\omega = 1$  and  $\ln(\omega) = \ln(1) = 0$

For imperfect crystals however there is some entropy associated with configuration of molecules and atoms even when all motions cease, hence the entropy in this case does not tend to zero as  $T \rightarrow 0$ , but it tends to a constant called the entropy of configuration.

The third law allows absolute entropy to be determined with zero entropy at absolute zero as the reference state. In refrigeration systems we deal with entropy changes only, the absolute entropy is not of much use. Therefore entropy may be taken to be zero or a constant at any suitably chosen reference state.

Another consequence of third law is that absolute zero cannot be achieved. One tries to approach absolute zero by magnetization to align the molecules. This is followed by cooling and then demagnetization, which extracts energy from the substance and reduces its temperature. It can be shown that this process will require infinite number of cycles to achieve absolute zero. In a later chapter it will be shown that infinitely large amount of work is required to maintain absolute zero if at all it can be achieved.

### Questions:

1. a) Prove the equivalence of Clausius and Kelvin statements. ([Solution](#))

b) Explain briefly about Carnot's corollaries? ([Solution](#))

2. Divide the following in to a) point function and path function and b) extensive property and intensive property.

Pressure, enthalpy, volume, temperature, specific volume, internal energy, work, heat, entropy, pressure, density, mass, and specific heat. ([Solution](#))

3. Gases enter the adiabatic converging nozzle of an aircraft with velocity  $V_1$  from combustion chamber. Find out the expression for the change in enthalpy between inlet and outlet of the nozzle, where inlet area  $A_1$  and outlet area  $A_2$  ( $A_2 < A_1$ ) are given and the nozzle is assumed to be horizontal. ([Solution](#))

4. 10 kW of electrical power input is given to a mechanical pump, which is pumping water from a well of depth 10 m. Pump is heated up because of frictional losses in the pump. In steady state, pump temperature is  $T_M = 40^\circ\text{C}$  and the surroundings is at  $T_S = 20^\circ\text{C}$ . The convective heat transfer between the motor surface area  $A_M (= 0.8 \text{ m}^2)$  and the surroundings air is governed by

$$Q = hA_M(T_M - T_S)$$

Where  $h = 0.15 \text{ kW/m}^2\text{-K}$ , is a convective heat transfer coefficient between the motor surface and the surrounding air. Find out the maximum mass flow rate of the water that mechanical pump can pump? ([Solution](#))

5. A refrigerator manufactured by one manufacturing company works between  $40^\circ\text{C}$  and  $-5^\circ\text{C}$ . The manufacturer claims that coefficient of performance of that refrigerator is 7.0. Do you agree with his statement? Justify your answer. ([Solution](#))

6. 2 kg of ice at  $-10^{\circ}\text{C}$  and 3 kg of water at  $70^{\circ}\text{C}$  are mixed in an insulated container. Find a) Equilibrium temperature of the system b) Entropy produced. ( $C_{ice} = 2.0934\text{kJ/kg}\cdot\text{K}$ ,  $L_{fusion} = 334.944\text{kJ/kg}$ ,  $C_{water} = 4.1868\text{kJ/kg}\cdot\text{K}$ ) ([Solution](#))

7. Answer the following true or false and justify your answer.

a) Change in the entropy of a closed system is the same for every process between two given states. ([Answer](#))

b) The entropy of a fixed amount of an incompressible substance increases in every process in which temperature decreases. ([Answer](#))

c) Entropy change of a system can become negative. ([Answer](#))

d) Entropy change of an isolated system can become negative. ([Answer](#))

e) A process which violates second law of thermodynamics also violates the first law of thermodynamics. ([Answer](#))

f) When a net amount of work is done on a closed system undergoing an internally reversible process, a net heat transfer from the system has to occur. ([Answer](#))

g) A closed system can experience an increase in entropy only when irreversibilities are present within the system during the process. ([Answer](#))

h) In an adiabatic and internally reversible process of a closed system, the entropy remains constant. ([Answer](#))

i) No process is allowed in which the entropies of both the system and the surroundings increase. ([Answer](#))

j) During a process the entropy of the system might decrease while the entropy of surroundings increase and conversely. ([Answer](#))

k) The value of coefficient of performance of heat pump is one greater than that of refrigerator. ([Answer](#))

# Lesson

5

Review of fundamental  
principles –  
Thermodynamics : Part II

.The specific objectives are to:

1. State principles of evaluating thermodynamic properties of pure substances using:
  - a) Equations of State (*Section 5.2*)
  - b) Thermodynamic charts (*Section 5.2*)
  - c) Thermodynamic tables (*Section 5.2*)
2. Derive expressions for heat and work transfer in important thermodynamic processes such as:
  - a) Isochoric process (*Section 5.3*)
  - b) Isobaric process (*Section 5.3*)
  - c) Isothermal process (*Section 5.3*)
  - d) Isentropic process (*Section 5.3*)
  - e) Isenthalpic process etc. (*Section 5.3*)

At the end of the lesson the student should be able to:

1. Evaluate thermodynamic properties using equations of state, tables and charts
2. Identify various regimes on T-s and P-h charts
3. Estimate heat and work transferred in various thermodynamic processes

## 5.1. Thermodynamic relations

There are some general thermodynamic relations, which are useful for determination of several thermodynamic properties from measured data on a few properties. The following relationships are generally used for the evaluation of entropy change. These are called  $T ds$  equations. They are obtained by applying first and second laws of thermodynamics

$$\begin{aligned} T ds &= du + p dv && \text{first } T ds \text{ equation} \\ T ds &= dh - v dP && \text{second } T ds \text{ equation} \end{aligned} \quad (5.1)$$

Two more fundamental thermodynamic relations can be obtained by defining two new properties called Gibbs and Helmholtz functions.

## 5.2. Evaluation of thermodynamic properties

In order to perform thermodynamic calculations, one has to know various thermodynamic properties of the system. Properties such as internal energy, enthalpy and entropy cannot be measured directly. Thermodynamics gives mathematical relations using which one can obtain properties, which cannot be measured directly in terms of the measurable properties such as pressure, temperature, volume, specific heat etc.

In general thermodynamic properties can be evaluated from:

1. Thermodynamic equations of state
2. Thermodynamic tables
3. Thermodynamic charts
4. Direct experimental results, and
5. The formulae of statistical thermodynamics

An equation of state (EOS) is a fundamental equation, which expresses the relationship between pressure, specific volume and temperature. The simplest equation of state is that for an incompressible substance (e.g. solids and liquids), which states that the specific volume is constant. The next simplest EOS is that for an ideal gas.

Ideal (perfect) gas equation is a special equation of state, which is applicable to ideal gases. The molecular forces of attraction between gas molecules are small compared to those in liquids. In the limit when these forces are zero, a gas is called a perfect gas. In addition the volume of the molecules should be negligible compared to total volume for a perfect gas. The perfect or ideal gas equation of state is given by:

$$Pv = RT \quad (5.2)$$

Where  $P$  = Absolute pressure  
 $v$  = Specific volume  
 $R$  = Gas constant  
 $T$  = Absolute temperature

The gas constant  $R$  is given by:

$$R = R_u / M \quad (5.3)$$

Where  $R_u$  = Universal gas constant  
 $M$  = Molecular weight

The ideal gas equation is satisfactory for low molecular mass, real gases at relatively high temperatures and low pressures. Ideal gas equation can be used for evaluating properties of moist air used in air conditioning applications without significant error.

For ideal gases, the change in internal energy and enthalpy are sole functions of temperature. Assuming constant [specific heats](#) ( $c_p, c_v$ ) in the temperature range  $T_1$  to  $T_2$ , for ideal gases one can write the change in internal energy ( $u$ ), enthalpy ( $h$ ) and entropy ( $s$ ) as:

$$\begin{aligned} u_2 - u_1 &= c_v(T_2 - T_1) \\ h_2 - h_1 &= c_p(T_2 - T_1) \\ s_2 - s_1 &= c_v \ln\left(\frac{T_2}{T_1}\right) + R \ln\left(\frac{v_2}{v_1}\right) \\ s_2 - s_1 &= c_p \ln\left(\frac{T_2}{T_1}\right) - R \ln\left(\frac{P_2}{P_1}\right) \\ c_p - c_v &= R \end{aligned} \quad (5.4)$$



The study of the properties of moist air is known as *psychrometry*. The *psychrometric properties* (temperature, humidity ratio, relative humidity, enthalpy etc.) are normally available in the form of charts, known as *psychrometric charts*. The psychrometric properties will be discussed in later chapters.

For gases with complex molecular structure or for real gases at high pressure and low temperatures or for gases approaching the saturated vapour region, the use of Ideal gas equation results in significant errors. Hence more complex but more realistic equations of states have to be applied. The accuracy of these EOS depend on the nature of the gas. Some of these EOSs are given below:

van der Waals equation:

$$\left(P + \frac{a}{v^2}\right)(v - b) = RT \quad (5.5)$$

where a and b are constants that account for the intermolecular forces and volume of the gas molecules respectively.

Redlich-Kwong equation:

$$P = \frac{RT}{v - b} - \frac{a}{\sqrt{T} v(v + b)} \quad (5.6)$$

A virial equation is more generalized form of equation of state. It is written as:

$$Pv = RT + \frac{A}{v} + \frac{B}{v^2} + \frac{C}{v^3} + \dots \quad (5.7)$$

where A,B,C,... are all empirically determined functions of temperature and are called as virial coefficients.

### 5.2.1. Properties Of Pure Substance

A pure substance is one whose chemical composition does not change during thermodynamic processes. Water and refrigerants are examples of pure substances. These days emphasis is on the use mixture of refrigerants. The properties of mixtures also require understanding of the properties of pure substances.

Water is a substance of prime importance in refrigeration and air-conditioning. It exists in three states namely, solid ice, liquid water and water vapour and undergoes transformation from one state to another. Steam and hot water are used for heating of buildings while chilled water is used for cooling of buildings. Hence, an understanding of its properties is essential for air conditioning calculations. Substances, which absorb heat from other substances or space, are called refrigerants. These substances also exist in three states. These also undergo transformations usually from liquid to vapour and vice-versa during heat absorption and rejection respectively. Hence, it is important to understand their properties also.

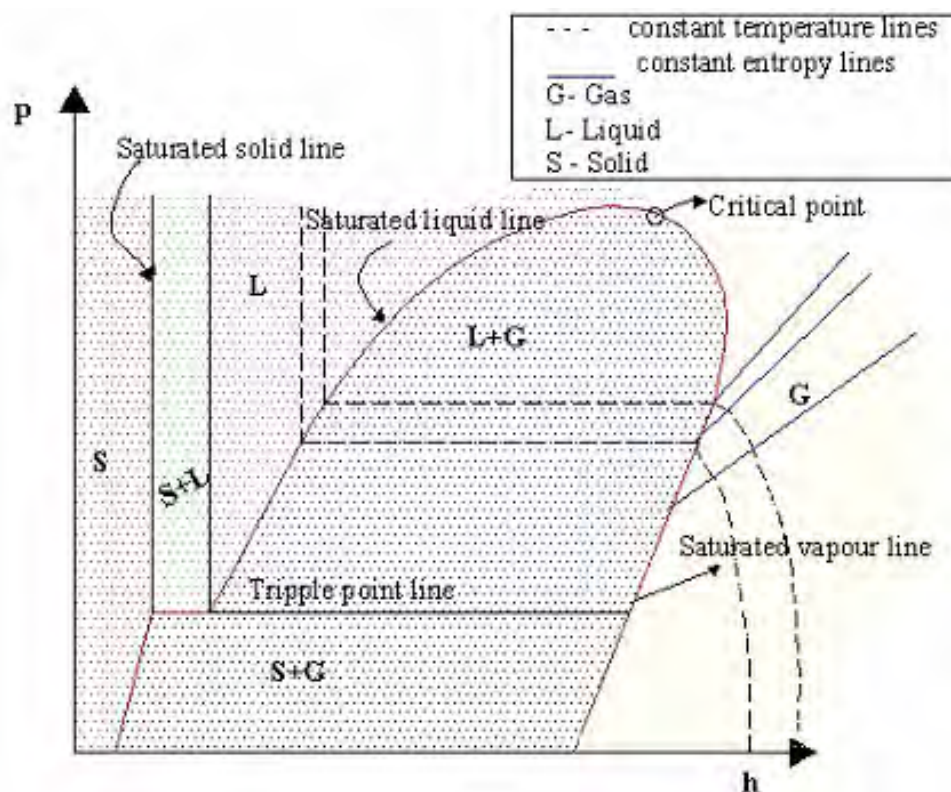
If a liquid (pure substance) is heated at constant pressure, the temperature at which it boils is called *saturation temperature*. This temperature will remain constant during heating until all the

liquid boils off. At this temperature, the liquid and the associated vapour at same temperature are in equilibrium and are called *saturated liquid and vapour* respectively. The saturation temperature of a pure substance is a function of pressure only. At atmospheric pressure, the saturation temperature is called *normal boiling point*. Similarly, if the vapour of a pure substance is cooled at constant pressure, the temperature at which the condensation starts, is called *dew point temperature*. For a pure substance, dew point and boiling point are same at a given pressure.

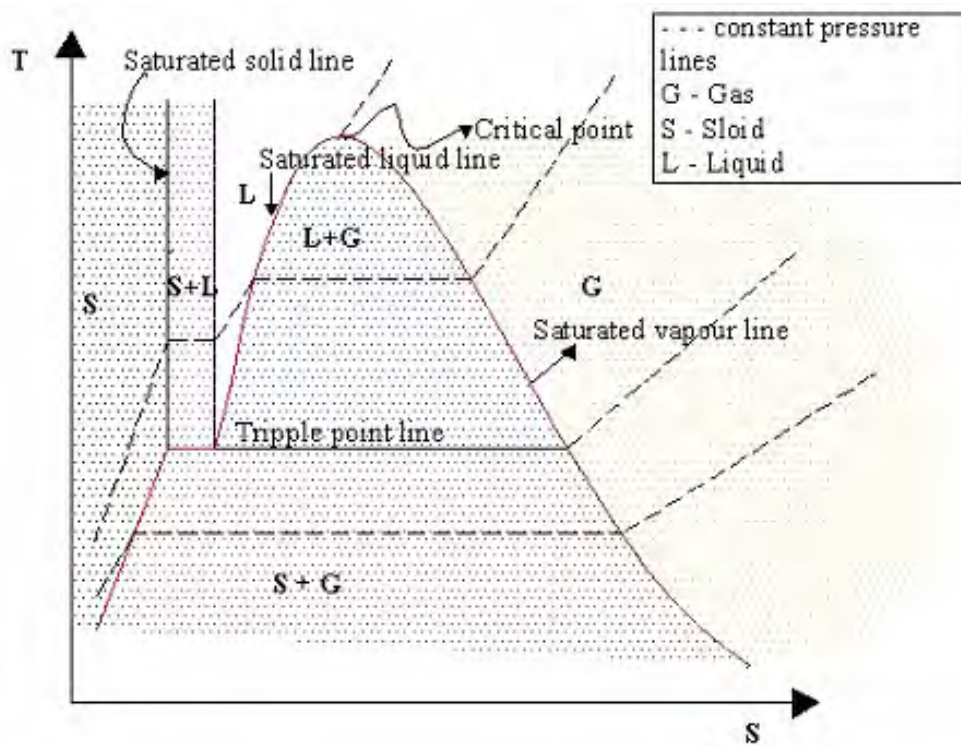
Similarly, when a solid is heated at constant, it melts at a definite temperature called melting point. Similarly cooling of a liquid causes freezing at the *freezing point*. The melting point and freezing point are same at same pressure for a pure substance and the solid and liquid are in equilibrium at this temperature.

For all pure substances there is a temperature at which all the three phases exist in equilibrium. This is called *triple point*.

The liquid-vapour phase diagram of pure substance is conveniently shown in temperature-entropy diagram or pressure-enthalpy diagram or  $p$ - $v$  diagram. Sometimes, three dimensional  $p$ - $v$ - $t$  diagrams are also drawn to show the phase transformation. In most of the refrigeration applications except dry ice manufacture, we encounter liquid and vapour phases only. Thermodynamic properties of various pure substances are available in the form of charts and tables. Thermodynamic property charts such as Temperature-entropy (T-s) charts, pressure-enthalpy (P-h) charts are very useful in evaluating properties of substances and also for representing the thermodynamic processes and cycles. Figures 5.1 and 5.2 show the P-h and T-s diagrams for pure substances.



**Fig. 5.1.** P-h diagram for a pure substance



*Fig. 5.2. T-s diagram for a pure substance*

Critical point :

Figures 5.1 and 5.2 show the critical point. The temperature, pressure and specific volume at critical point are denoted by  $T_c$ ,  $P_c$  and  $v_c$ , respectively. A liquid below the critical pressure when heated first becomes a mixture of liquid and vapour and then becomes saturated vapour and finally a superheated vapour. At critical point there is no distinction between liquid state and vapour state; these two merge together. At constant pressure greater than critical pressure,  $P_c$  when liquid is heated in supercritical region, there is no distinction between liquid and vapour; as a result if heating is done in a transparent tube, the meniscus of liquid and vapour does not appear as transformation from liquid to vapour takes place. At pressures below critical pressure, when a liquid is heated there is a clear-cut meniscus between liquid and vapour, until all the liquid evaporates.

For water: Triple point: 0.1 °C, 0.006112 bar  
 Critical point: 221.2 bar, 647.3K and 0.00317 m<sup>3</sup>/kg

For Dry Ice (CO<sub>2</sub>): Triple point: 5.18 bar, -56.6 °C  
 Critical point: 73.8 bar, 31°C

**T-s and p-h diagrams for liquid-vapour regime**

These are of great importance in refrigeration cycle calculations. Figure 5.3 and 5.4 show typical T-s diagram and p-h (Mollier) diagrams, respectively for a pure refrigerant. The T-s diagram

shows two constant pressure lines for pressures  $P_1$  and  $P_2$  where  $P_1 > P_2$ . The constant pressure line 1-2-3-4 is for pressure  $P_1$ . The portion 1-2 is in the sub-cooled region, 2-3 is in wet region, that is mixture of liquid and vapour, and 3-4 is in superheated region. A frequent problem in refrigeration cycle calculations is to find the properties of sub-cooled liquid at point  $a$  shown in the figure. The liquid at pressure  $P_1$  and temperature  $T_a$  is sub-cooled liquid. The liquid at state  $a'$  is saturated liquid at lower pressure  $P_a$ , but at the same temperature.

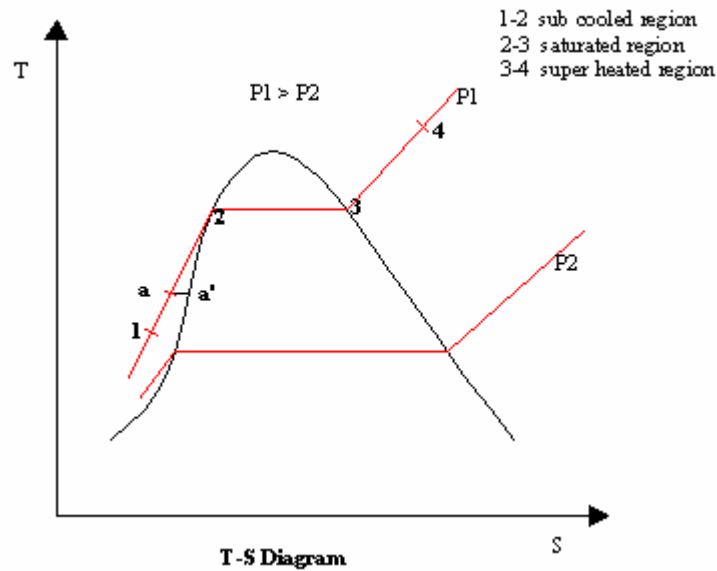


Fig. 5.3. T-s diagram of a pure substance

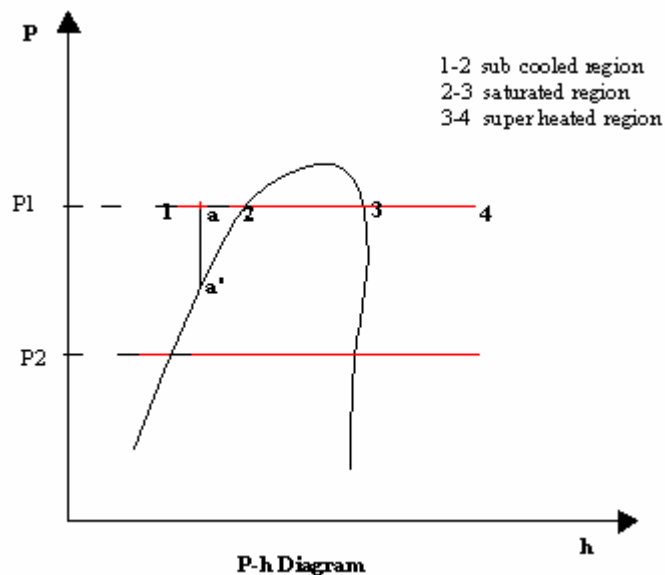


Fig. 5.4. P-h diagram of a pure substance

From 1<sup>st</sup> T ds equation , Eq. (5.1):

$$T ds = du + P dv \quad (5.1a)$$

If the liquid is assumed to be incompressible then  $dv = 0$  and

$$T ds = du \quad (5.8)$$

For liquids, the internal energy may be assumed to be function of temperature alone, that is,

$$u_a = u_{a'}, \text{ because } T_a = T_{a'} \text{ this implies that } s_a = s_{a'}$$

Therefore states  $a$  and  $a'$  are coincident.

Also from the 2<sup>nd</sup> T ds equation, Eq. (5.1)

$$T ds = dh - v dP \quad (5.1b)$$

The specific volume  $v$  is small for liquids hence  $v dp$  is also negligible, therefore  $h_a = h_{a'}$ , That is, the enthalpy of sub-cooled liquid is equal to the enthalpy of saturated liquid at liquid temperature. For all practical purposes the constant pressure lines are assumed to be coincident with saturated liquid line in the sub-cooled region. *This is a very useful concept.*

T-s diagram gives a lot of information about the refrigeration cycle. It was observed in Chapter 4 that for a reversible process, the heat transfer is related to the change in entropy given by:

$$S_2 - S_1 = \left( \int_1^2 \frac{\delta Q}{T} \right)_{\text{int rev}}, \text{ this implies that } {}_1Q_2 = \left( \int_1^2 T.ds \right) \quad (5.9)$$

The above equation implies that the heat transferred in a reversible process 1-2 is equal to area under the line 1-2 on the T-s diagram.

Also, from Eq. (5.1b),  $T ds = dh - v dP$ , hence for a constant pressure process ( $dP = 0$ ), therefore, for a constant pressure process  $Tds = dh$ , which means that for an isobaric process the area under the curve is equal to change in enthalpy on T-s diagram.

### Properties at Saturation

The properties of refrigerants and water for saturated states are available in the form of Tables. The properties along the saturated liquid line are indicated by subscript 'f' for example  $v_f, u_f, h_f$  and  $s_f$  indicate specific volume, internal energy, enthalpy and entropy of saturated liquid respectively. The corresponding saturated vapour states are indicated by subscript 'g' for example  $v_g, u_g, h_g$  and  $s_g$  respectively. All properties with subscript 'fg' are the difference between saturated vapour and saturated liquid states. For example,  $h_{fg} = h_g - h_f$ , the latent heat of vaporization.

The specific volume, internal energy, enthalpy and entropy of the mixture in two-phase region may be found in terms of quality, 'x' of the mixture. The quality of the mixture denotes the mass

(kg) of the vapour per unit mass (kg) of the mixture. That is there is x kg of vapour and (1-x) kg of liquid in one kg of the mixture.

Therefore the properties of the liquid-vapour mixture can be obtained by using the following equations:

$$\begin{aligned} v &= (1-x)v_f + x.v_g = v_f + x.v_{fg} \\ u &= (1-x)u_f + x.u_g = u_f + x.u_{fg} \\ h &= (1-x)h_f + x.h_g = h_f + x.h_{fg} \\ s &= (1-x)s_f + x.s_g = s_f + x.s_{fg} \end{aligned} \quad (5.10)$$

The table of properties at saturation is usually temperature based. For each temperature it lists the values of saturation pressure ( $P_{sat}$ ),  $v_f$ ,  $v_g$ ,  $h_f$ ,  $h_g$ ,  $s_f$  and  $s_g$ . Two reference states or datum or used in these tables. In ASHRAE reference  $h_f = 0.0$  kJ/kg and  $s_f = 1.0$  kJ/kg.K at  $-40^\circ\text{C}$ . In IIR reference  $h_f = 200.00$  kJ/kg and  $s_f = 1.0$  kJ/kg-K at  $0^\circ\text{C}$ .

The properties in the superheated region are given in separate tables. The values of v, h and s are tabulated along constant pressure lines (that is, at saturation pressures corresponding to, say  $0^\circ\text{C}$ ,  $1^\circ\text{C}$ ,  $2^\circ\text{C}$  etc.) at various values of degree of superheat.

### Clapeyron Equation

The Clapeyron equation represents the dependence of saturation pressure on saturation temperature (boiling point). This is given by,

$$\frac{dP_{sat}}{dT} = \frac{s_{fg}}{v_{fg}} = \frac{h_{fg}}{(v_g - v_f)T} \quad (5.11)$$

Some useful relations can be derived using Clapeyron equation. The specific volume of liquid is very small compared to that of vapour, hence it may be neglected and then perfect gas relation  $pv_g = RT$  may be used to yield:

$$\frac{dP_{sat}}{dT} = \frac{h_{fg}}{(v_g - v_f)T} = \frac{h_{fg}}{v_g T} = \frac{P_{sat} \cdot h_{fg}}{RT^2} \quad (5.12)$$

This may be integrated between states 1 to an arbitrary state  $P_{sat}$ , T to yield

$$\int_{P_1}^P \frac{dP_{sat}}{P_{sat}} = \frac{h_{fg}}{R} \int_{T_1}^T \frac{dT}{T^2} \quad \text{or} \quad \ln \frac{P_{sat}}{P_1} = \frac{h_{fg}}{R} \left( \frac{1}{T_1} - \frac{1}{T} \right) \quad (5.13)$$

If  $P_1$  is chosen as standard atmospheric pressure of say 1 atm. ( $\ln(P_1) = \ln(1) = 0$ ), and P is measured in atmospheres, then  $T_1 = T_{nb}$  is the normal boiling point of the substance, then from Eq. (5.13), we obtain:

$$\ln(P_{sat}) = \frac{h_{fg}}{R} \left( \frac{1}{T_{nb}} - \frac{1}{T} \right) \quad (5.14)$$

Therefore if  $\ln(P)$  is plotted against  $1/T$ , the saturated vapour line will be a straight line. Also, it has been observed that for a set of similar substances the product of  $Mh_{fg}/T_{nb}$  called Trouton number is constant. Here  $M$  is the molecular weight of the substance (kg/kmole). If we denote the Trouton number by  $N_{trouton}$ , then

$$N_{trouton} = \frac{Mh_{fg}}{T_{nb}}$$

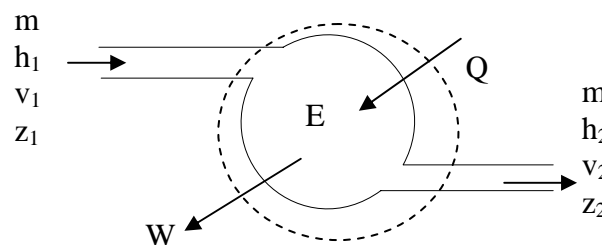
$$\frac{h_{fg}}{RT_{nb}} = \frac{N_{trouton}}{MR} = \frac{N_{trouton}}{R}, \text{ or} \quad (5.15)$$

$$\ln p = \frac{h_{fg}}{RT} + \frac{N_{trouton}}{R}$$

For most of the substances, the Trouton number value is found to be about 85 kJ/kmole.K

### 5.3. Thermodynamic processes

In most of the refrigeration and air conditioning systems, the mass flow rates do not change with time or the change is very small, in such cases one can assume the flow to be steady. For such systems, the energy balance equation (1<sup>st</sup> law of thermodynamics) is known as steady-flow energy equation.



**Fig. 5.5.** Steady flow energy balance on a control volume

For the open system shown in Fig. 5.5, it is given by:

$$m\left(h_1 + \frac{v_1^2}{2} + gz_1\right) + Q = m\left(h_2 + \frac{v_2^2}{2} + gz_2\right) + W \quad (5.16)$$

In many cases, compared to other terms, the changes in kinetic and potential energy terms, i.e.,  $(v_1^2 - v_2^2)/2$  and  $(gz_1 - gz_2)$  are negligible.

Heating and cooling: During these processes normally there will be no work done either on the system or by the system, i.e.,  $\underline{W=0}$ . Hence, the energy equation for cooling/heating becomes:

$$Q + mh_1 = mh_2 \quad \text{or} \quad Q = m(h_2 - h_1) \quad (5.17)$$

Some of the important thermodynamic processes encountered in refrigeration and air conditioning are discussed below.

Constant volume (isochoric) process: An example of this process is the heating or cooling of a gas stored in a rigid cylinder. Since the volume of the gas does not change, no external work is done, and work transferred  $\Delta W$  is zero. Therefore from 1<sup>st</sup> law of thermodynamics for a constant volume process:

$$\begin{aligned} {}_1W_2 &= 0 \\ {}_1Q_2 &= \int_1^2 dU = U_2 - U_1 = mc_{v,avg}(T_2 - T_1) \\ S_2 - S_1 &= mc_{v,avg} \ln\left(\frac{T_2}{T_1}\right) \end{aligned} \quad (5.18)$$

The above equation implies that for a constant volume process in a closed system, the heat transferred is equal to the change in internal energy of the system. If 'm' is the mass of the gas,  $C_v$  is its specific heat at constant volume which remains almost constant in the temperature range  $\Delta T$ , and  $\Delta T$  is the temperature change during the process, then:

$$\Delta Q = \Delta U = m.C_v.\Delta T \quad (5.19)$$

Constant pressure (isobaric) process: If the temperature of a gas is increased by the addition of heat while the gas is allowed to expand so that its pressure is kept constant, the volume of the gas will increase in accordance with Charles law. Since the volume of the gas increases during the process, work is done by the gas at the same time that its internal energy also changes. Therefore for constant pressure process, assuming constant specific heats and ideal gas behaviour,

$$\begin{aligned} {}_1Q_2 &= (U_2 - U_1) + {}_1W_2 \\ {}_1W_2 &= \int_1^2 PdV = P \times (V_2 - V_1) \\ {}_1Q_2 &= m(h_2 - h_1) = m \times C_{p,avg} \times (T_2 - T_1) \\ S_2 - S_1 &= mc_{p,avg} \ln\left(\frac{T_2}{T_1}\right) \end{aligned} \quad (5.20)$$

Constant temperature (isothermal) process: According to Boyle's law, when a gas is compressed or expanded at constant temperature, the pressure will vary inversely with the volume. Since the gas does work as it expands, if the temperature is to remain constant, energy to do the work must be supplied from an external source. When a gas is compressed, work is done on the gas and if the gas is not cooled during the process the internal energy of the gas will increase by an amount equal to the work of compression. Therefore if the temperature of the gas is to remain constant during the process gas must reject heat to the surroundings. Since there is no temperature increase in the system change in internal energy becomes zero. And the amount of work done will be the amount of heat supplied. So for isothermal process



$$\begin{aligned} {}_1Q_2 &= (U_2 - U_1) + {}_1W_2 \\ {}_1W_2 &= \int_1^2 P.dV \end{aligned} \quad (5.21)$$

If the working fluid behaves as an ideal gas and there are no phase changes, then, the work done, heat transferred and entropy change during the isothermal process are given by:

$$\begin{aligned} {}_1Q_2 &= {}_1W_2 \quad (\because U = f(T)) \\ {}_1W_2 &= \int_1^2 P.dV = mRT \ln\left(\frac{v_2}{v_1}\right) = mRT \ln\left(\frac{P_1}{P_2}\right) \\ S_2 - S_1 &= mR \ln\left(\frac{v_2}{v_1}\right) = mR \ln\left(\frac{P_1}{P_2}\right) \end{aligned} \quad (5.22)$$

Adiabatic process: An adiabatic process is one in which no heat transfer takes place to or from the system during the process. For a fluid undergoing an adiabatic process, the pressure and volume satisfy the following relation:

$$PV^k = \text{constant} \quad (5.23)$$

where  $k$  is the coefficient of adiabatic compression or expansion. For an ideal gas, it can be shown that:

$$PV^\gamma = \text{constant, where } \gamma = \frac{C_p}{C_v} \quad (5.24)$$

Applying first law of thermodynamics for an adiabatic process, we get:

$$\begin{aligned} {}_1Q_2 &= (U_2 - U_1) + {}_1W_2 = 0 \\ {}_1W_2 &= \int_1^2 P.dV = \left(\frac{k}{k-1}\right)(P_2V_2 - P_1V_1) = (U_1 - U_2) \end{aligned} \quad (5.25)$$

If the process is reversible, adiabatic then the process is also isentropic:

$${}_1Q_2 = \int_1^2 T.dS = 0 \Rightarrow S_1 = S_2 \quad (5.26)$$

The following P-V-T relationships can be derived for a compressible fluid undergoing an adiabatic process:

$$\frac{T_2}{T_1} = \left(\frac{V_1}{V_2}\right)^{k-1} = \left(\frac{P_2}{P_1}\right)^{(k-1)/k} \quad (5.27)$$

If the adiabatic process is reversible, then from the definition of entropy, the process becomes an *isentropic process* or the entropy of the system does not change during a reversible adiabatic process. Hence all reversible, adiabatic processes are isentropic processes, however, the converse is not true, i.e., all isentropic processes need not be reversible, adiabatic processes.

Polytropic process: When a gas undergoes a reversible process in which there is heat transfer, the process frequently takes place in such a way that a plot of  $\log P$  vs  $\log V$  is a straightline, implying that:

$$PV^n = \text{constant} \quad (5.28)$$

The value of  $n$  can vary from  $-\infty$  to  $+\infty$ , depending upon the process. For example:

For an isobaric process,  $n = 0$  and  $P = \text{constant}$   
 For an isothermal process,  $n = 1$  and  $T = \text{constant}$   
 For an isentropic process,  $n = k$  and  $s = \text{constant}$ , and  
 For an isochoric process,  $n = -\infty$  and  $v = \text{constant}$

For a polytropic process, expressions for work done, heat transferred can be derived in the same way as that of a adiabatic process discussed above, i.e.,

$$\begin{aligned} {}_1W_2 &= \frac{n}{(n-1)}(P_2V_2 - P_1V_1) \\ (U_2 - U_1) &= mc_{v,avg}(T_2 - T_1) \\ {}_1Q_2 &= (U_2 - U_1) + \frac{n}{(n-1)}(P_2V_2 - P_1V_1) \\ S_2 - S_1 &= \int_1^2 \frac{dU}{T} + \int_1^2 \frac{PdV}{T} \end{aligned} \quad (5.29)$$

The above expressions are valid for all values of  $n$ , except  $n = 1$  (isothermal process)

Throttling (Isenthalpic) process: A throttling process occurs when a fluid flowing through a passage suddenly encounters a restriction in the passage. The restriction could be due to the presence of an almost completely closed valve or due to sudden and large reduction in flow area etc. The result of this restriction is a sudden drop in the pressure of the fluid as it is forced to flow through the restriction. This is a highly irreversible process and is used to reduce the pressure and temperature of the refrigerant in a refrigeration system. Since generally throttling occurs in a small area, it may be considered as an adiabatic process (as area available for heat transfer is negligibly small) also since no external work is done, we can write the 1<sup>st</sup> law of thermodynamics for this process as:

$$\begin{aligned} \dot{Q} = \dot{W} &= 0 \\ h_1 + \frac{V_1^2}{2} &= h_2 + \frac{V_2^2}{2} \end{aligned} \quad (5.30)$$

where  $V_1$  and  $V_2$  are the inlet and exit velocities of the fluid respectively. The areas of inlet and outlet of a throttling device are designed in such a way that velocities at inlet and outlet become almost equal. Then the above equation becomes

$$h_1 = h_2 \quad (5.31)$$

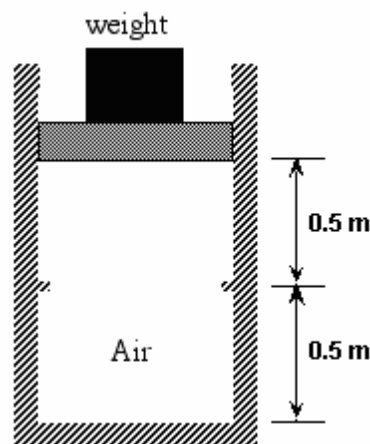
Thus throttling process is an isenthalpic process.

Though throttling is an expansion process, it is fundamentally different from expansion taking place in a turbine. The expansion of a fluid in a turbine yields useful work output, and can approach a reversible process (e.g. isentropic process), whereas expansion by throttling is highly irreversible. Depending upon the throttling conditions and the nature of the fluid, the exit temperature may be greater than or equal to or less than the inlet temperature.

**Questions:**

1. Prove T dS equations starting from basic laws of thermodynamics? ([Solution](#))
2. An interesting feature of the process of cooling the human body by evaporation is that the heat extracted by the evaporation of a gram of perspiration from the human skin at body temperature (37°C) is quoted in physiology books as 580 calories/gm rather than the nominal 540 calories/gm at the normal boiling point. Why is it larger at body temperature? ([Solution](#))
3. Find the saturation temperature, the changes in specific volume and entropy during evaporation, and the latent heat of vaporization of steam at 0.1 MPa ? ([Solution](#))
4. Under what conditions of pressure and temperature does saturated steam have a entropy of 6.4448 kJ/kg K? State the specific volume and entropy under such conditions. ([Solution](#))
5. Find the enthalpy of steam when the pressure is 2 MPa and the specific volume is 0.09 m<sup>3</sup>/kg. ([Solution](#))
6. A gas of mass 4 kg is adiabatically expanded in a cylinder from 0.2 m<sup>3</sup> to 0.5 m<sup>3</sup> Initial pressure of the gas is 2 bar, and the gas follows the following pressure-volume relationship  

$$PV^{1.4} = K \text{ (K= constant)}$$
 Find the decrease in the temperature of the gas? ( $C_v$  for the gas = 0.84 kJ/kg-K) ([Solution](#))
7. Air is contained in a vertical cylinder that is fitted with a frictionless piston. A set of stops is provided 0.5 m below the initial position of the piston. The piston cross-sectional area is 0.5 m<sup>2</sup> and the air inside is initially at 100 kPa and 400 K. The air is slowly cooled as a result of heat transfer to the surroundings.



- a) Sketch these two processes on P-V and T-V diagrams
- b) What is the temperature of the air inside the cylinder when the piston reaches the stops?

- c) After the piston hits the stops, the cooling is continued until the temperature reaches 100 K. What is the pressure at this state?
- d) How much work is done by the system in the first cooling process?
- e) How much work is done by the system in the second cooling process?

Assume air to be a thermally perfect gas and the first cooling is a quasi-static process. ([Solution](#))

8. Consider a thermodynamic system containing air at  $V_1=1 \text{ m}^3/\text{kg}$ ,  $P_1=100 \text{ kPa}$ . The system is compressed to  $0.5 \text{ m}^3/\text{kg}$  via any one of three quasi-static processes: isobaric, isothermal, or adiabatic. Assume that  $c_v = 0.7165 \text{ kJ/kg-K}$ , and  $R = 0.287 \text{ kJ/kg-K}$ .

- a) Sketch all three processes on the same P-V diagram.
- b) For each process determine the pressure and temperature at the final state.
- c) For each process determine the work done by the system and the heat transferred to the system. ([Solution](#))

# Lesson 6 Review of fundamentals: Fluid flow

The specific objective of this lesson is to conduct a brief review of the fundamentals of fluid flow and present:

1. A general equation for conservation of mass and specific equations for steady and incompressible flows
2. A general equation for conservation of momentum in integral form and discuss simplifications
3. Bernoulli equation and introduce the concepts of total, static and velocity pressures
4. Modified Bernoulli equation and introduce expression for head loss and fan/pump power
5. Methods for evaluating friction pressure drops with suitable correlations for friction factor
6. The concept of minor losses

At the end of the lesson, the student should be able to:

1. Write the general equation of mass transfer and be able to reduce it for incompressible and steady flows
2. Write the general equation of momentum transfer and reduce it to incompressible, steady flows
3. Apply equations of conservation of mass and momentum to simple problems
4. Write Bernoulli equation and define static, velocity and datum pressures and heads
5. Write modified Bernoulli equation to account for frictional losses and presence of fan/pump
6. Apply Bernoulli and modified Bernoulli equations to simple fluid flow problems relevant to refrigeration and air conditioning
7. Estimate friction pressure drops and minor losses

## 6.1. Fluid flow

In refrigeration and air-conditioning systems various fluids such as air, water and refrigerants flow through pipes and ducts. The flow of these fluids is subjected to certain fundamental laws. The subject of “Fluid Mechanics” deals with these aspects. In the present lesson, fundamentals of fluid flow relevant to refrigeration and air conditioning is discussed. Fluid flow in general can be compressible, i.e., the density of the fluid may vary along the flow direction. However in most of the refrigeration and air conditioning applications the density variations may be assumed to be negligible. Hence, the fluid flow for such systems is treated as incompressible. This assumption simplifies the fluid flow problem considerably. This assumption is valid as long as the velocity fluid is considerably less than the velocity of sound (Mach number, ratio of fluid velocity to sonic velocity less than 0.3). To analyze the fluid flow problems, in addition to energy conservation (1<sup>st</sup> law of thermodynamics), one has to consider the conservation of mass and momentum.

### 6.1.1. Conservation of mass:

As the name implies, this law states that mass is a conserved parameter, i.e., it can neither be generated nor destroyed; it can only be transferred. Mathematically, the equation of conservation of mass for a control volume is given by:

$$\frac{\partial}{\partial t} \int_{CV} \rho dV + \int_{CS} \rho \vec{V} \cdot d\vec{A} = 0 \quad (6.1)$$

The first term on the left represents the rate of change of mass within the control volume, while the second term represents the net rate of mass flux through the control surface. The above equation is also known as *continuity equation*.

In most of the refrigeration and air conditioning systems, the fluid flow is usually steady, i.e., the mass of the control volume does not change with time. For such a steady flow process, Eq. (6.1) becomes:

$$\int_{CS} \rho \vec{V} \cdot d\vec{A} = 0 \quad (6.2)$$

If we apply the above steady flow equation to a duct shown in Fig. 6.1, we obtain:

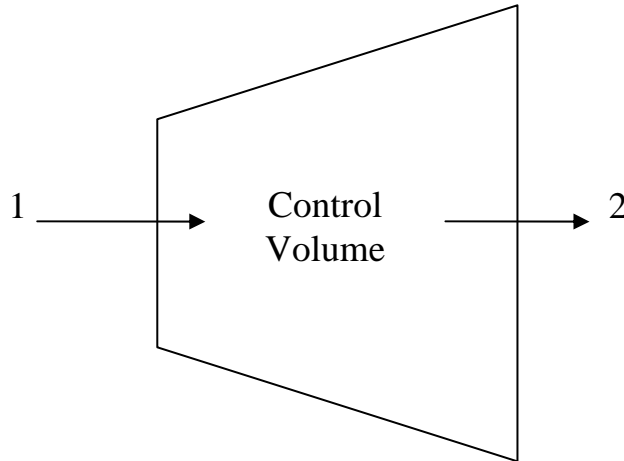


Fig. 6.1. Steady fluid flow through a duct

$$\dot{m}_1 = \rho_1 A_1 V_1 = \rho_2 A_2 V_2 = \dot{m}_2 = \dot{m} \quad (6.3)$$

where  $\dot{m}$  is the mass flow rate of fluid through the control volume,  $\rho$ ,  $A$  and  $V$  are the density, cross sectional area and velocity of the fluid respectively.

If we assume that the flow is incompressible ( $\rho_1 = \rho_2 = \rho$ ), then the above equation reduces to:

$$A_1 V_1 = A_2 V_2 \quad (6.4)$$

The above equation implies that when  $A_1 > A_2$ , then  $V_1 < V_2$ , that is velocity increases in the direction of flow. Such a section is called a *nozzle*. On the other hand, if  $A_1 <$

$A_2$ , then  $V_1 > V_2$  and velocity reduces in the direction of flow, this type of section is called as *diffuser*.

### 6.1.2. Conservation of momentum:

The momentum equation is mathematical expression for the Newton's second law applied to a control volume. Newton's second law for fluid flow relative to an inertial coordinate system (control volume) is given as:

$$\left. \frac{d\vec{P}}{dt} \right)_{\text{control volume}} = \frac{\partial}{\partial t} \int_{CV} v\rho dV + \int_{CS} v\rho\vec{V} \cdot d\vec{A} = \vec{F})_{\text{on control volume}}$$

and

$$\vec{F})_{\text{on control volume}} = \sum \vec{F}_S + \sum \vec{F}_B = \frac{\partial}{\partial t} \int_{CV} v\rho dV + \int_{CS} v\rho\vec{V} \cdot d\vec{A}$$
(6.5)

In the above equation,  $\left. \frac{d\vec{P}}{dt} \right)_{\text{control volume}}$  is the rate of change of linear momentum of the control volume,  $\vec{F})_{\text{on control volume}}$  is the summation of all the forces acting on the control volume,  $\sum \vec{F}_S$  and  $\sum \vec{F}_B$  are the net surface and body forces acting on the control volume,  $\vec{V}$  is the velocity vector with reference to the control volume and  $v$  is the velocity (momentum per unit mass) with reference to an inertial (non-accelerating) reference frame. When the control volume is not accelerating (i.e., when it is stationary or moving with a constant velocity), then  $\vec{V}$  and  $v$  refer to the same reference plane.

The above equation states that the sum of all forces (surface and body) acting on a non accelerating control volume is equal to the sum of the rate of change of momentum inside the control volume and the net rate of flux of momentum out through the control surface. For steady state the linear momentum equation reduces to:

$$\vec{F} = \vec{F}_S + \vec{F}_B = \int_{CS} \vec{V}\rho\vec{V} \cdot d\vec{A} \quad \text{for steady state} \quad (6.6)$$

The surface forces consist of all the forces transmitted across the control surface and may include pressure forces, force exerted by the physical boundary on the control surface etc. The most common body force encountered in most of the fluid flow problems is the gravity force acting on the mass inside the control volume.

The linear momentum equation discussed above is very useful in the solution of many fluid flow problems. Some of the applications of this equation are: force exerted by the fluid flow on nozzles, bends in a pipe, motion of rockets, water hammers etc. [Example](#) shows the application of linear momentum equation.

The moment-of-momentum equation is the equation of conservation of angular momentum. It states that the net moment applied to a system is equal to the rate of



change of angular momentum of the system. This equation is applied for hydraulic machines such as pumps, turbines, compressors etc.

### 6.1.3. Bernoulli's equation:

The Bernoulli's equation is one of the most useful equations that is applied in a wide variety of fluid flow related problems. This equation can be derived in different ways, e.g. by integrating Euler's equation along a [streamline](#), by applying first and second laws of thermodynamics to [steady, irrotational, inviscid](#) and incompressible flows etc. In simple form the Bernoulli's equation relates the pressure, velocity and elevation between any two points in the flow field. It is a scalar equation and is given by:

$$\begin{array}{ccccccc} \frac{p}{\rho g} & + & \frac{V^2}{2g} & + & z & = & H = \text{constant} \\ \downarrow & & \downarrow & & \downarrow & & \downarrow \\ \text{pressure} & & \text{velocity} & & \text{static} & & \text{total} \\ \text{head} & & \text{head} & & \text{head} & & \text{head} \end{array} \quad (6.7)$$

Each term in the above equation has dimensions of length (i.e., meters in SI units) hence these terms are called as pressure head, velocity head, static head and total heads respectively. Bernoulli's equation can also be written in terms of pressures (i.e., Pascals in SI units) as:

$$\begin{array}{ccccccc} p & + & \rho \frac{V^2}{2} & + & \rho g z & = & p_T \\ \downarrow & & \downarrow & & \downarrow & & \downarrow \\ \text{static} & & \text{velocity} & & \text{pressure due} & & \text{total} \\ \text{pressure} & & \text{pressure} & & \text{to datum} & & \text{pressure} \end{array} \quad (6.8)$$

Bernoulli's equation is valid between any two points in the flow field when the flow is *steady, irrotational, inviscid and incompressible*. The equation is valid along a streamline *for rotational, steady and incompressible flows*. Between any two points 1 and 2 in the flow field for irrotational flows, the Bernoulli's equation is written as:

$$\frac{p_1}{\rho g} + \frac{V_1^2}{2g} + z_1 = \frac{p_2}{\rho g} + \frac{V_2^2}{2g} + z_2 \quad (6.9)$$

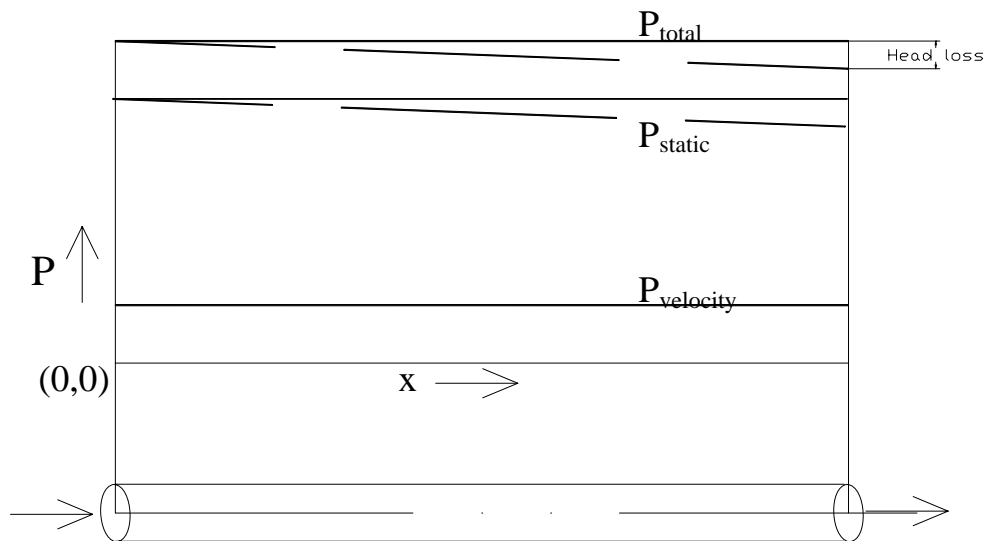
Bernoulli's equation can also be considered to be an alternate statement of conservation of energy (1<sup>st</sup> law of thermodynamics). The equation also implies the possibility of conversion of one form of pressure into other. For example, neglecting the pressure changes due to datum, it can be concluded from Bernoulli's equation that the static pressure rises in the direction of flow in a diffuser while it drops in the direction of flow in case of nozzle due to conversion of velocity pressure into static pressure and vice versa. Figure 6.2 shows the variation of total, static and velocity pressure for steady, incompressible and inviscid, fluid flow through a pipe of uniform cross-section.

Since all real fluids have finite viscosity, i.e. in all actual fluid flows, some energy will be lost in overcoming friction. This is referred to as head loss, i.e. if the fluid

were to rise in a vertical pipe it will rise to a lower height than predicted by Bernoulli's equation. The head loss will cause the pressure to decrease in the flow direction. If the head loss is denoted by  $H_l$ , then Bernoulli's equation can be modified to:

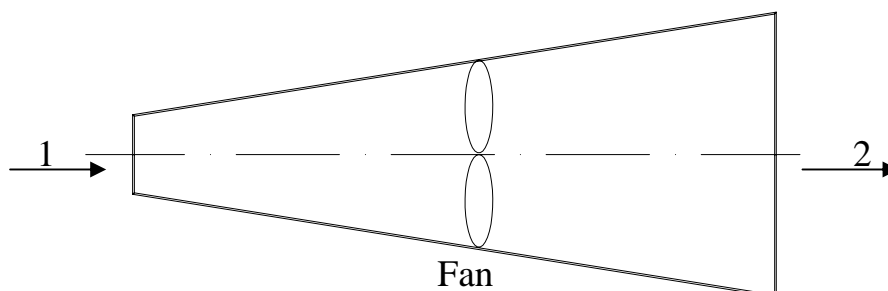
$$\frac{p_1}{\rho g} + \frac{V_1^2}{2g} + z_1 = \frac{p_2}{\rho g} + \frac{V_2^2}{2g} + z_2 + H_l \quad (6.10)$$

Figure 6.2 shows the variation of total, static and velocity pressure for steady, incompressible fluid flow through a pipe of uniform cross-section without viscous effects (solid line) and with viscous effects (dashed lines).



**Fig. 6.2.** Application of Bernoulli equation to pipe flow

Since the total pressure reduces in the direction of flow, sometimes it becomes necessary to use a pump or a fan to maintain the fluid flow as shown in Fig. 6.3.



**Fig. 6.3.** Air flow through a duct with a fan

Energy is added to the fluid when fan or pump is used in the fluid flow conduit (Fig. 6.3), then the modified Bernoulli equation is written as:

$$\frac{p_1}{\rho g} + \frac{V_1^2}{2g} + z_1 + H_p = \frac{p_2}{\rho g} + \frac{V_2^2}{2g} + z_2 + H_l \quad (6.11)$$

where  $H_p$  is the gain in head due to fan or pump and  $H_l$  is the loss in head due to friction. When fan or pump is used, the power required ( $W$ ) to drive the fan/pump is given by:

$$W = \left( \frac{\dot{m}}{\eta_{fan}} \right) \left( \frac{(p_2 - p_1)}{\rho} + \frac{(V_2^2 - V_1^2)}{2} + g(z_2 - z_1) + \frac{gH_l}{\rho} \right) \quad (6.12)$$

where  $\dot{m}$  is the mass flow rate of the fluid and  $\eta_{fan}$  is the energy efficiency of the fan/pump. Some of the terms in the above equation can be negligibly small, for example, for air flow the potential energy term  $g(z_2 - z_1)$  is quite small compared to the other terms. For liquids, the kinetic energy term  $(v_2^2 - v_1^2)/2$  is relatively small. If there is no fan or pump then  $W$  is zero.

#### 6.1.4. Pressure loss during fluid flow:

The loss in pressure during fluid flow is due to:

- a) Fluid friction and turbulence
- b) Change in fluid flow cross sectional area, and
- c) Abrupt change in the fluid flow direction

Normally pressure drop due to fluid friction is called as major loss or frictional pressure drop  $\Delta p_f$  and pressure drop due to change in flow area and direction is called as minor loss  $\Delta p_m$ . The total pressure drop is the summation of frictional pressure drop and minor loss. In most of the situations, the temperature of the fluid does not change appreciably along the flow direction due to pressure drop. This is due to the fact that the temperature tends to rise due to energy dissipation by fluid friction and turbulence, at the same time temperature tends to drop due to pressure drop. These two opposing effects more or less cancel each other and hence the temperature remains almost constant (assuming no heat transfer to or from the surroundings).

#### Evaluation of frictional pressure drop:

When a fluid flows through a pipe or a duct, the relative velocity of the fluid at the wall of the pipe/duct will be zero, and this condition is known as a *no-slip condition*. The no-slip condition is met in most of the common fluid flow problems (however, there are special circumstances under which the no-slip condition is not satisfied). As a result of this a velocity gradient develops inside the pipe/duct beginning with zero at the wall to a maximum, normally at the axis of the conduit. The velocity profile at any cross section depends on several factors such as the type of fluid flow (i.e. [laminar or](#)

[turbulent](#)), condition of the walls (e.g. adiabatic or non-adiabatic) etc. This velocity gradient gives rise to shear stresses ultimately resulting in frictional pressure drop.

The Darcy-Weisbach equation is one of the most commonly used equations for estimating frictional pressure drops in internal flows. This equation is given by:

$$\Delta p_f = f \frac{L}{D} \left( \frac{\rho V^2}{2} \right) \quad (6.13)$$

where  $f$  is the dimensionless friction factor,  $L$  is the length of the pipe/duct and  $D$  is the diameter in case of a circular duct and hydraulic diameter in case of a noncircular duct. The friction factor is a function of Reynolds number,  $Re_D = \left( \frac{\rho V D}{\mu} \right)$  and the relative surface of the pipe or duct surface in contact with the fluid.

For steady, [fully developed](#), laminar, incompressible flows, the Darcy friction factor  $f$  (which is independent of surface roughness) is given by:

$$f = \frac{64}{Re_D} \quad (6.14)$$

For turbulent flow, the friction factor can be evaluated using the empirical correlation suggested by Colebrook and White is used, the correlation is given by:

$$\frac{1}{\sqrt{f}} = -2 \log_{10} \left[ \frac{k_s}{3.7D} + \frac{2.51}{(Re_D)\sqrt{f}} \right] \quad (6.15)$$

Where  $k_s$  is the average roughness of inner pipe wall expressed in same units as the diameter  $D$ . Evaluation of  $f$  from the above equation requires iteration since  $f$  occurs on both the sides of it.

ASHRAE suggests the following form for determination of friction factor,

$$f_1 = 0.11 \left( \frac{k_s}{D} + \frac{0.68}{Re_D} \right)^{0.25} \quad (6.16)$$

If  $f_1$  determined from above equation equals or exceeds 0.018 then  $f$  is taken to be same as  $f_1$ . If it is less than 0.018 then  $f$  is given by:

$$f = 0.85f_1 + 0.0028 \quad (6.17)$$

Another straightforward equation suggested by Haaland (1983) is as follows:

$$\frac{1}{f^{1/2}} \approx -1.8 \log_{10} \left[ \frac{6.9}{Re_D} + \left( \frac{k_s/D}{3.7} \right)^{1.11} \right] \quad (6.18)$$

### Evaluation of minor loss, $\Delta p_m$ :

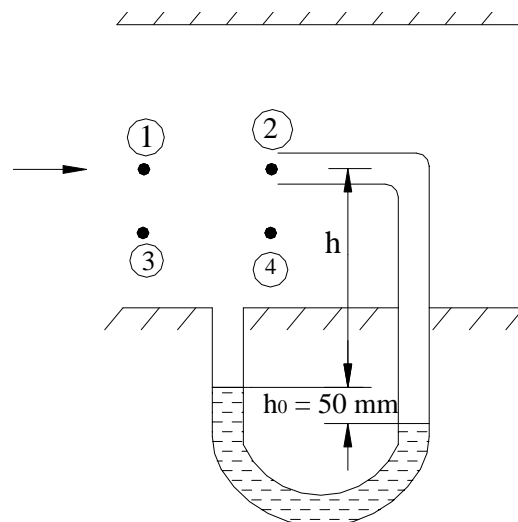
The process of converting static pressure into kinetic energy is quite efficient. However, the process of converting kinetic energy into pressure head involves losses. These losses, which occur in ducts because of bends, elbows, joints, valves etc. are called minor losses. This term could be a misnomer, since in many cases these are more significant than the losses due to friction. For almost all the cases, the minor losses are determined from experimental data. In turbulent flows, the loss is proportional to square of velocity. Hence these are expressed as:

$$\Delta p_m = K \frac{\rho V^2}{2} \quad (6.19)$$

Experimental values for the constant K are available for various valves, elbows, diffusers and nozzles and other fittings. These aspects will be discussed in a later chapter on distribution of air.

### **Questions:**

1. Is the flow incompressible if the velocity field is given by  $\vec{V} = 2x^3\vec{i} - 6x^2y\vec{j} + t\vec{k}$ ? [\(Answer\)](#)
2. Derive the expression of fully developed laminar flow velocity profile through a circular pipe using control volume approach. [\(Answer\)](#)
3. A Static-pitot (Fig. Q3) is used to measure the flow of an inviscid fluid having a density of  $1000 \text{ kg/m}^3$  in a 100 mm diameter pipe. What is the flow rate through the duct assuming the flow to be steady and incompressible and mercury as the manometer fluid? [\(Solution\)](#)



*Fig. Q3. Figure of problem 3*

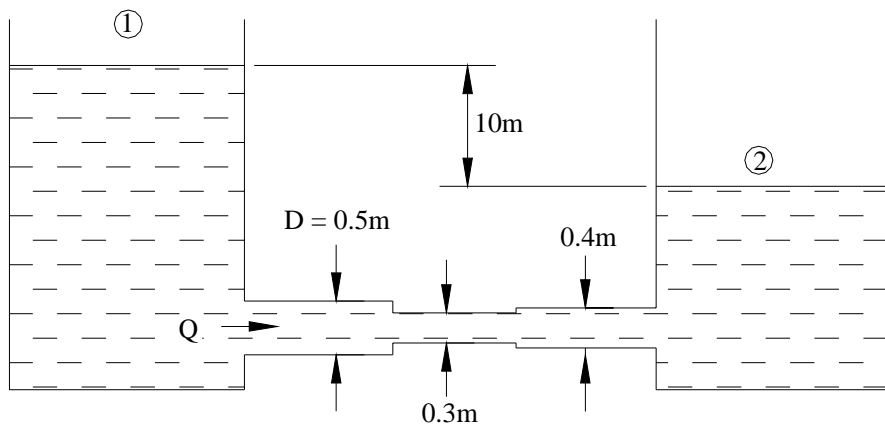
4. Calculate the pressure drop in 30 m of a rectangular duct of cross section 12.5 mm X 25 mm when saturated water at  $60^\circ\text{C}$  flows at 5 cm/s? [\(Solution\)](#) Hint: Lundgren

determined that for rectangular ducts with ratio of sides 0.5 the product of  $f.Re=62.19$ .

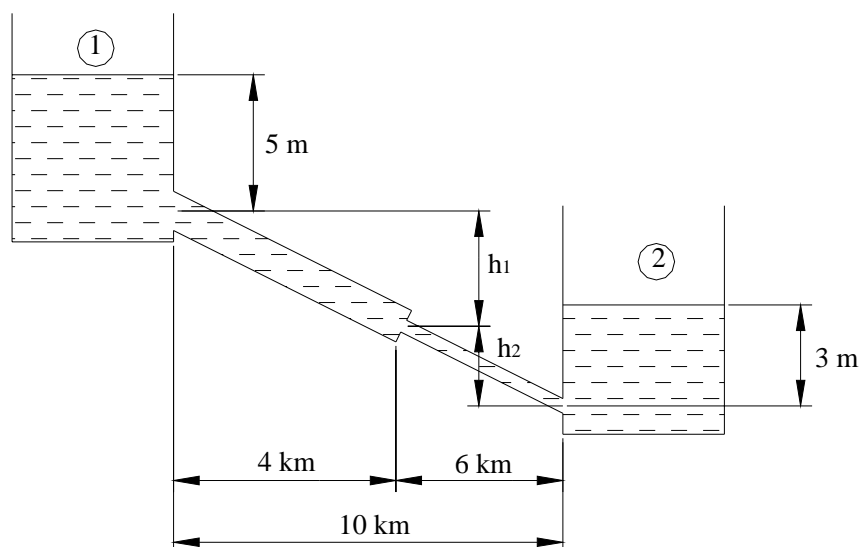
5. A fluid is flowing through a pipeline having a diameter of 150 mm at 1 m/s. The pipe is 50 m long. Calculate the head loss due to friction? ([Solution](#)) (Density and viscosity of fluid are  $850 \text{ kg/m}^3$  and  $0.08 \text{ kg/m.s}$  respectively)

6. A fluid flows from point 1 to 2 of a horizontal pipe having a diameter of 150 mm. The distance between the points is 100 m. The pressure at point 1 is 1 MPa and at point 2 is 0.9 MPa. What is the flow rate? ([Solution](#)) (Density and kinematic viscosity of fluid are  $900 \text{ kg/m}^3$  and  $400 \times 10^{-6} \text{ m}^2/\text{s}$  respectively)

7. Three pipes of 0.5 m, 0.3 m and 0.4 m diameters and having lengths of 100 m, 60 m and 80 m respectively are connected in series between two tanks whose difference in water levels is 10 m as shown in Fig. Q7. If the friction factor for all the pipes is equal to 0.05, calculate the flow rate through the pipes. ([Solution](#))



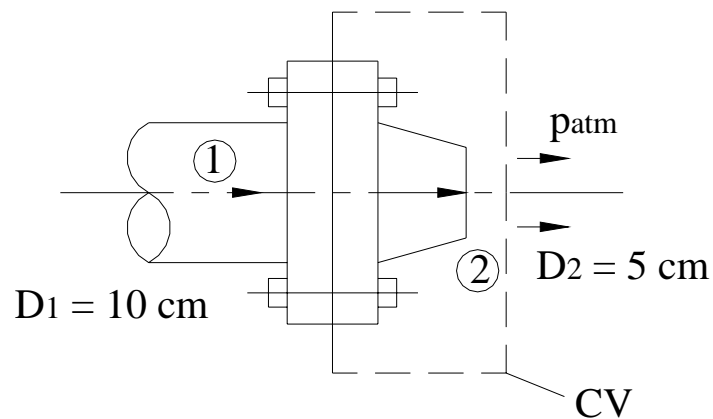
*Fig. Q7. Figure of problem 7*



*Fig. Q8. Figure of problem 8*

8. Two reservoirs 10 kms apart is connected by a pipeline which is 0.25 m in diameter in the first 4 kms, sloping at 5 m per km, and the remaining by a 0.15 m diameter sloping at 2 m per km as is shown in Fig. Q8. The levels of water above the pipe openings are 5 m and 3 m in the upper and lower reservoirs respectively. Taking  $f = 0.03$  for both pipes and neglecting contraction and exit losses at openings calculate the rate of discharge through the pipelines. ([Solution](#))

9. A 10 cm hose with 5 cm discharges water at  $3 \text{ m}^3/\text{min}$  to the atmosphere as is shown in Fig. Q9. Assuming frictionless flow, calculate the force exerted on the flange bolts. ([Solution](#))



*Fig. Q9. Figure of problem 9*

# Lesson 7 Review of fundamentals: Heat and Mass transfer



## The objective of this lesson is to review fundamentals of heat and mass transfer and discuss:

1. Conduction heat transfer with governing equations for heat conduction, concept of thermal conductivity with typical values, introduce the concept of heat transfer resistance to conduction
2. Radiation heat transfer and present Planck's law, Stefan-Boltzmann equation, expression for radiative exchange between surfaces and the concept of radiative heat transfer resistance
3. Convection heat transfer, concept of hydrodynamic and thermal boundary layers, Newton's law of cooling, convective heat transfer coefficient with typical values, correlations for heat transfer in forced convection, free convection and phase change, introduce various non-dimensional numbers
4. Basics of mass transfer – Fick's law and convective mass transfer
5. Analogy between heat, momentum and mass transfer
6. Multi-mode heat transfer, multi-layered walls, heat transfer networks, overall heat transfer coefficients
7. Fundamentals of heat exchangers

At the end of the lesson the student should be able to:

1. Write basic equations for heat conduction and derive equations for simpler cases
2. Write basic equations for radiation heat transfer, estimate radiative exchange between surfaces
3. Write convection heat transfer equations, indicate typical convective heat transfer coefficients. Use correlations for estimating heat transfer in forced convection, free convection and phase change
4. Express conductive, convective and radiative heat transfer rates in terms of potential and resistance.
5. Write Fick's law and convective mass transfer equation
6. State analogy between heat, momentum and mass transfer
7. Evaluate heat transfer during multi-mode heat transfer, through multi-layered walls etc. using heat transfer networks and the concept of overall heat transfer coefficient
8. Perform basic calculation on heat exchangers

### 7.1. Introduction

Heat transfer is defined as energy-in-transit due to temperature difference. Heat transfer takes place whenever there is a temperature gradient within a system or whenever two systems at different temperatures are brought into thermal contact. Heat, which is energy-in-transit cannot be measured or observed directly, but the effects produced by it can be observed and measured. Since heat transfer involves transfer and/or conversion of energy, all heat transfer processes must obey the first and second laws of thermodynamics. However unlike thermodynamics, heat transfer

deals with systems not in thermal equilibrium and using the heat transfer laws it is possible to find the rate at which energy is transferred due to heat transfer. From the engineer's point of view, estimating the rate of heat transfer is a key requirement. Refrigeration and air conditioning involves heat transfer, hence a good understanding of the fundamentals of heat transfer is a must for a student of refrigeration and air conditioning. This section deals with a brief review of heat transfer relevant to refrigeration and air conditioning.

Generally heat transfer takes place in three different modes: conduction, convection and radiation. In most of the engineering problems heat transfer takes place by more than one mode simultaneously, i.e., these heat transfer problems are of multi-mode type.

## 7.2. Heat transfer

### 7.2.1. Conduction heat transfer:

Conduction heat transfer takes place whenever a temperature gradient exists in a stationary medium. Conduction is one of the basic modes of heat transfer. On a microscopic level, conduction heat transfer is due to the elastic impact of molecules in fluids, due to molecular vibration and rotation about their lattice positions and due to free electron migration in solids.

The fundamental law that governs conduction heat transfer is called Fourier's law of heat conduction, it is an empirical statement based on experimental observations and is given by:

$$Q_x = -k.A.\frac{dT}{dx} \quad (7.1)$$

In the above equation,  $Q_x$  is the rate of heat transfer by conduction in x-direction,  $(dT/dx)$  is the temperature gradient in x-direction,  $A$  is the cross-sectional area normal to the x-direction and  $k$  is a proportionality constant and is a property of the conduction medium, called thermal conductivity. The '-' sign in the above equation is a consequence of 2<sup>nd</sup> law of thermodynamics, which states that in spontaneous process heat must always flow from a high temperature to a low temperature (i.e.,  $dT/dx$  must be negative).

The thermal conductivity is an important property of the medium as it is equal to the conduction heat transfer per unit cross-sectional area per unit temperature gradient. Thermal conductivity of materials varies significantly. Generally it is very high for pure metals and low for non-metals. Thermal conductivity of solids is generally greater than that of fluids. Table 7.1 shows typical thermal conductivity values at 300 K. Thermal conductivity of solids and liquids vary mainly with temperature, while thermal conductivity of gases depend on both temperature and pressure. For isotropic materials the value of thermal conductivity is same in all directions, while for anisotropic materials such as wood and graphite the value of thermal conductivity is different in different directions. In refrigeration and air conditioning high thermal conductivity materials are used in the construction of heat exchangers, while low

thermal conductivity materials are required for insulating refrigerant pipelines, refrigerated cabinets, building walls etc.

Table 7.1. Thermal conductivity values for various materials at 300 K

Material	Thermal conductivity (W/m K)
Copper (pure)	399
Gold (pure)	317
Aluminum (pure)	237
Iron (pure)	80.2
Carbon steel (1 %)	43
Stainless Steel (18/8)	15.1
Glass	0.81
Plastics	0.2 – 0.3
Wood (shredded/cemented)	0.087
Cork	0.039
Water (liquid)	0.6
Ethylene glycol (liquid)	0.26
Hydrogen (gas)	0.18
Benzene (liquid)	0.159
Air	0.026

### General heat conduction equation:

Fourier's law of heat conduction shows that to estimate the heat transfer through a given medium of known thermal conductivity and cross-sectional area, one needs the spatial variation of temperature. In addition the temperature at any point in the medium may vary with time also. The spatial and temporal variations are obtained by solving the heat conduction equation. The heat conduction equation is obtained by applying first law of thermodynamics and Fourier's law to an elemental control volume of the conducting medium. In rectangular coordinates, the general heat conduction equation for a conducting media with constant thermo-physical properties is given by:

$$\frac{1}{\alpha} \frac{\partial T}{\partial \tau} = \left[ \frac{\partial^2 T}{\partial x^2} + \frac{\partial^2 T}{\partial y^2} + \frac{\partial^2 T}{\partial z^2} \right] + \frac{q_g}{k} \quad (7.2)$$

In the above equation,  $\alpha = \frac{k}{\rho c_p}$  is a property of the media and is called as thermal diffusivity,  $q_g$  is the rate of heat generation per unit volume inside the control volume and  $\tau$  is the time.

The general heat conduction equation given above can be written in a compact form using the Laplacian operator,  $\nabla^2$  as:

$$\frac{1}{\alpha} \frac{\partial T}{\partial \tau} = \nabla^2 T + \frac{q_g}{k} \quad (7.3)$$

If there is no heat generation inside the control volume, then the conduction equation becomes:

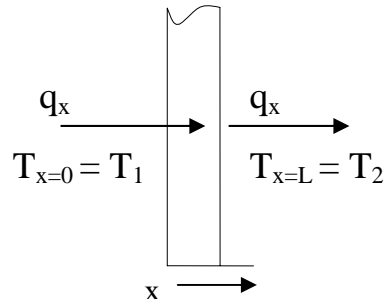
$$\frac{1}{\alpha} \frac{\partial T}{\partial \tau} = \nabla^2 T \quad (7.4)$$

If the heat transfer is steady and temperature does not vary with time, then the equation becomes:

$$\nabla^2 T = 0 \quad (7.5)$$

The above equation is known as Laplace equation.

The solution of heat conduction equation along with suitable initial and boundary conditions gives temperature as a function of space and time, from which the temperature gradient and heat transfer rate can be obtained. For example for a simple case of one-dimensional, steady heat conduction with no heat generation (Fig. 7.1), the governing equation is given by:



**Fig. 7.1.** Steady 1-D heat conduction

$$\frac{d^2 T}{dx^2} = 0 \quad (7.6)$$

The solution to the above equation with the specified boundary conditions is given by:

$$T = T_1 + (T_2 - T_1) \frac{x}{L} \quad (7.7)$$

and the heat transfer rate,  $Q_x$  is given by:

$$Q_x = -k A \frac{dT}{dx} = k A \left( \frac{T_1 - T_2}{L} \right) = \left( \frac{\Delta T}{R_{\text{cond}}} \right) \quad (7.8)$$

where  $\Delta T = T_1 - T_2$  and resistance to conduction heat transfer,  $R_{\text{cond}} = (L/kA)$

Similarly for one-dimensional, steady heat conduction heat transfer through a cylindrical wall the temperature profile and heat transfer rate are given by:

$$T = T_1 - (T_1 - T_2) \frac{\ln(r/r_1)}{\ln(r_2/r_1)} \quad (7.9)$$

$$Q_r = -kA \frac{dT}{dr} = 2\pi kL \frac{(T_1 - T_2)}{\ln(r_2/r_1)} = \left( \frac{\Delta T}{R_{cyl}} \right) \quad (7.10)$$

where  $r_1$ ,  $r_2$  and  $L$  are the inner and outer radii and length of the cylinder and  $R_{cyl} = \frac{\ln(r_2/r_1)}{2\pi LK}$  is the heat transfer resistance for the cylindrical wall.

From the above discussion it is clear that the steady heat transfer rate by conduction can be expressed in terms of a potential for heat transfer ( $\Delta T$ ) and a resistance for heat transfer  $R$ , analogous to Ohm's law for an electrical circuit. This analogy with electrical circuits is useful in dealing with heat transfer problems involving multiplayer heat conduction and multimode heat transfer.

Temperature distribution and heat transfer rates by conduction for complicated, multi-dimensional and transient cases can be obtained by solving the relevant heat conduction equation either by analytical methods or numerical methods.

### 7.2.2. Radiation heat transfer:

Radiation is another fundamental mode of heat transfer. Unlike conduction and convection, radiation heat transfer does not require a medium for transmission as energy transfer occurs due to the propagation of electromagnetic waves. A body due to its temperature emits electromagnetic radiation, and it is emitted at all temperatures. It is propagated with the speed of light ( $3 \times 10^8$  m/s) in a straight line in vacuum. Its speed decreases in a medium but it travels in a straight line in homogenous medium. The speed of light,  $c$  is equal to the product of wavelength  $\lambda$  and frequency  $\nu$ , that is,

$$c = \lambda \nu \quad (7.11)$$

The wave length is expressed in Angstrom ( $1 \text{ \AA} = 10^{-10}$  m) or micron ( $1 \mu\text{m} = 10^{-6}$  m). Thermal radiation lies in the range of 0.1 to 100  $\mu\text{m}$ , while visible light lies in the range of 0.35 to 0.75  $\mu\text{m}$ . Propagation of thermal radiation takes place in the form of discrete quanta, each quantum having energy of

$$E = h\nu \quad (7.12)$$

Where,  $h$  is Plank's constant,  $h = 6.625 \times 10^{-34}$  Js. The radiation energy is converted into heat when it strikes a body.

The radiation energy emitted by a surface is obtained by integrating [Planck's equation](#) over all the wavelengths. For a real surface the radiation energy given by Stefan-Boltzmann's law is:

$$Q_r = \epsilon \cdot \sigma \cdot A \cdot T_s^4 \quad (7.13)$$

where  $Q_r$  = Rate of thermal energy emission, W

$\epsilon$	=	Emissivity of the surface
$\sigma$	=	Stefan-Boltzmann's constant, $5.669 \times 10^{-8} \text{ W/m}^2 \cdot \text{K}^4$
$A$	=	Surface area, $\text{m}^2$
$T_s$	=	Surface Temperature, K

The emissivity is a property of the radiating surface and is defined as the emissive power (energy radiated by the body per unit area per unit time over all the wavelengths) of the surface to that of an ideal radiating surface. The ideal radiator is called as a "black body", whose emissivity is 1. A black body is a hypothetical body that absorbs all the incident (all wave lengths) radiation. The term 'black' has nothing to do with black colour. A white coloured body can also absorb infrared radiation as much as a black coloured surface. A hollow enclosure with a small hole is an approximation to black body. Any radiation that enters through the hole is absorbed by multiple reflections within the cavity. The hole being small very small quantity of it escapes through the hole.

The radiation heat exchange between any two surfaces 1 and 2 at different temperatures  $T_1$  and  $T_2$  is given by:

$$Q_{1-2} = \sigma \cdot A \cdot F_\epsilon F_A (T_1^4 - T_2^4) \quad (7.14)$$

where	$Q_{1-2}$	=	Radiation heat transfer between 1 and 2, W
	$F_\epsilon$	=	Surface optical property factor
	$F_A$	=	Geometric shape factor
	$T_1, T_2$	=	Surface temperatures of 1 and 2, K

Calculation of radiation heat transfer with known surface temperatures involves evaluation of factors  $F_\epsilon$  and  $F_A$ .

Analogous to Ohm's law for conduction, one can introduce the concept of thermal resistance in radiation heat transfer problem by linearizing the above equation:

$$Q_{1-2} = \frac{(T_1 - T_2)}{R_{\text{rad}}} \quad (7.15)$$

where the radiative heat transfer resistance  $R_{\text{rad}}$  is given by:

$$R_{\text{rad}} = \left( \frac{T_1 - T_2}{\sigma A F_\epsilon F_A (T_1^4 - T_2^4)} \right) \quad (7.16)$$

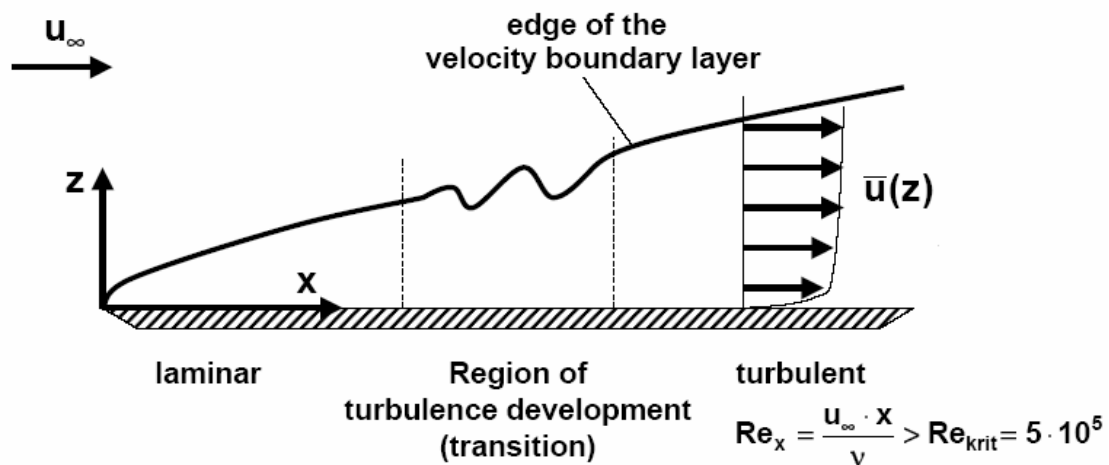
### 7.2.3. Convection Heat Transfer:

Convection heat transfer takes place between a surface and a moving fluid, when they are at different temperatures. In a strict sense, convection is not a basic mode of heat transfer as the heat transfer from the surface to the fluid consists of two mechanisms operating simultaneously. The first one is energy transfer due to molecular motion (conduction) through a fluid layer adjacent to the surface, which remains stationary with respect to the solid surface due to no-slip condition. Superimposed upon this conductive mode is energy transfer by the macroscopic motion of fluid particles by virtue of an external force, which could be generated by a pump or fan (forced convection) or generated due to buoyancy, caused by density gradients.

When fluid flows over a surface, its velocity and temperature adjacent to the surface are same as that of the surface due to the no-slip condition. The velocity and temperature far away from the surface may remain unaffected. The region in which the velocity and temperature vary from that of the surface to that of the free stream are called as hydrodynamic and thermal boundary layers, respectively. Figure 7.2 show that fluid with free stream velocity  $U_\infty$  flows over a flat plate. In the vicinity of the surface as shown in Figure 7.2, the velocity tends to vary from zero (when the surface is stationary) to its free stream value  $U_\infty$ . This happens in a narrow region whose thickness is of the order of  $Re_L^{-0.5}$  ( $Re_L = U_\infty L/\nu$ ) where there is a sharp velocity gradient. This narrow region is called hydrodynamic boundary layer. In the hydrodynamic boundary layer region the inertial terms are of same order magnitude as the viscous terms. Similarly to the velocity gradient, there is a sharp temperature gradient in this vicinity of the surface if the temperature of the surface of the plate is different from that of the flow stream. This region is called thermal boundary layer,  $\delta_t$  whose thickness is of the order of  $(Re_L Pr)^{-0.5}$ , where Pr is the Prandtl number, given by:

$$Pr = \frac{c_{p,f} \mu_f}{k_f} = \frac{\nu_f}{\alpha_f} \quad (7.17)$$

In the expression for Prandtl number, all the properties refer to the flowing fluid.



*Fig. 7.2. Velocity distribution of flow over a flat plate*

In the thermal boundary layer region, the conduction terms are of same order of magnitude as the convection terms.

The momentum transfer is related to kinematic viscosity  $\nu$  while the diffusion of heat is related to thermal diffusivity  $\alpha$  hence the ratio of thermal boundary layer to viscous boundary layer is related to the ratio  $\nu/\alpha$ , Prandtl number. From the expressions for boundary layer thickness it can be seen that the ratio of thermal boundary layer thickness to the viscous boundary layer thickness depends upon Prandtl number. For large Prandtl numbers  $\delta_t < \delta$  and for small Prandtl numbers,  $\delta_t > \delta$ . It can also be seen that as the Reynolds number increases, the boundary layers become narrow, the temperature gradient becomes large and the heat transfer rate increases.

Since the heat transfer from the surface is by molecular conduction, it depends upon the temperature gradient in the fluid in the immediate vicinity of the surface, i.e.

$$Q = -kA \left( \frac{dT}{dy} \right)_{y=0} \quad (7.18)$$

Since temperature difference has been recognized as the potential for heat transfer it is convenient to express convective heat transfer rate as proportional to it, i.e.

$$Q = -k_f A \left( \frac{dT}{dy} \right)_{y=0} = h_c A (T_w - T_\infty) \quad (7.19)$$

The above equation defines the convective heat transfer coefficient  $h_c$ . This equation  $Q = h_c A (T_w - T_\infty)$  is also referred to as Newton's law of cooling. From the above equation it can be seen that the convective heat transfer coefficient  $h_c$  is given by:

$$h_c = \frac{-k_f \left( \frac{dT}{dy} \right)_{y=0}}{(T_w - T_\infty)} \quad (7.20)$$

The above equation suggests that the convective heat transfer coefficient (hence heat transfer by convection) depends on the temperature gradient  $\left( \frac{dT}{dy} \right)_{y=0}$  near the

surface in addition to the thermal conductivity of the fluid and the temperature difference. The temperature gradient near the wall depends on the rate at which the fluid near the wall can transport energy into the mainstream. Thus the temperature gradient depends on the flow field, with higher velocities able to pressure sharper temperature gradients and hence higher heat transfer rates. Thus determination of convection heat transfer requires the application of laws of fluid mechanics in addition to the laws of heat transfer.

Table 7.2 Typical order-of magnitude values of convective heat transfer coefficients

Type of fluid and flow	Convective heat transfer coefficient $h_c$ (W/m <sup>2</sup> K)
Air, free convection	6 – 30
Water, free convection	20 – 100
Air or superheated steam, forced convection	30 – 300
Oil, forced convection	60 – 1800
Water, forced convection	300 – 18000
Synthetic refrigerants, boiling	500 - 3000
Water, boiling	3000 – 60000
Synthetic refrigerants, condensing	1500 - 5000
Steam, condensing	6000 – 120000

Traditionally, from the manner in which the convection heat transfer rate is defined, evaluating the convective heat transfer coefficient has become the main objective of



the problem. The convective heat transfer coefficient can vary widely depending upon the type of fluid and flow field and temperature difference. Table 7.2 shows typical order-of-magnitude values of convective heat transfer coefficients for different conditions.

### **Convective heat transfer resistance:**

Similar to conduction and radiation, convective heat transfer rate can be written in terms of a potential and resistance, i.e.,

$$Q = h_c A(T_w - T_\infty) = \frac{(T_w - T_\infty)}{R_{\text{conv}}} \quad (7.21)$$

where the convective heat transfer resistance,  $R_{\text{conv}} = 1/(h_c A)$

### **Determination of convective heat transfer coefficient:**

Evaluation of convective heat transfer coefficient is difficult as the physical phenomenon is quite complex. Analytically, it can be determined by solving the mass, momentum and energy equations. However, analytical solutions are available only for very simple situations, hence most of the convection heat transfer data is obtained through careful experiments, and the equations suggested for convective heat transfer coefficients are mostly empirical. Since the equations are of empirical nature, each equation is applicable to specific cases. Generalization has been made possible to some extent by using several non-dimensional numbers such as Reynolds number, Prandtl number, Nusselt number, Grashoff number, Rayleigh number etc. Some of the most important and commonly used correlations are given below:

### **Heat transfer coefficient inside tubes, ducts etc.:**

When a fluid flows through a conduit such as a tube, the fluid flow and heat transfer characteristics at the entrance region will be different from the rest of the tube. Flow in the entrance region is called as developing flow as the boundary layers form and develop in this region. The length of the entrance region depends upon the type of flow, type of surface, type of fluid etc. The region beyond this entrance region is known as fully developed region as the boundary layers fill the entire conduit and the velocity and temperature profiles remains essentially unchanged. In general, the entrance effects are important only in short tubes and ducts. Correlations are available in literature for both entrance as well as fully developed regions. In most of the practical applications the flow will be generally fully developed as the lengths used are large. The following are some important correlations applicable to fully developed flows:

#### **a) Fully developed laminar flow inside tubes (internal diameter D):**

Constant wall temperature condition:

$$\text{Nusselt number, } Nu_D = \left( \frac{h_c D}{k_f} \right) = 3.66 \quad (7.22)$$

Constant wall heat flux condition:

$$\text{Nusselt number, } Nu_D = \left( \frac{h_c D}{k_f} \right) = 4.364 \quad (7.23)$$

**b) Fully developed turbulent flow inside tubes (internal diameter D):**

Dittus-Boelter Equation:

$$\text{Nusselt number, } Nu_D = \left( \frac{h_c D}{k_f} \right) = 0.023 Re_D^{0.8} Pr^n \quad (7.24)$$

where  $n = 0.4$  for heating ( $T_w > T_f$ ) and  $n = 0.3$  for cooling ( $T_w < T_f$ ).

The Dittus-Boelter equation is valid for smooth tubes of length  $L$ , with  $0.7 < Pr < 160$ ,  $Re_D > 10000$  and  $(L/D) > 60$ .

Petukhov equation: This equation is more accurate than Dittus-Boelter and is applicable to rough tubes also. It is given by:

$$Nu_D = \frac{Re_D Pr}{X} \left( \frac{f}{8} \right) \left( \frac{\mu_b}{\mu_w} \right)^n \quad (7.25)$$

where  $X = 1.07 + 12.7(Pr^{2/3} - 1) \left( \frac{f}{8} \right)^{1/2}$

where  $n = 0.11$  for heating with uniform wall temperature  
 $n = 0.25$  for cooling with uniform wall temperature, and  
 $n = 0$  for uniform wall heat flux or for gases

' $f$ ' in Petukhov equation is the friction factor, which needs to be obtained using suitable correlations for smooth or rough tubes.  $\mu_b$  and  $\mu_w$  are the dynamic viscosities of the fluid evaluated at bulk fluid temperature and wall temperatures respectively. Petukhov equation is valid for the following conditions:

$$\begin{aligned} 10^4 < Re_D < 5 \times 10^6 \\ 0.5 < Pr < 200 & \quad \text{with 5 percent error} \\ 0.5 < Pr < 2000 & \quad \text{with 10 percent error} \\ 0.08 < (\mu_b/\mu_w) < 40 \end{aligned}$$

**c) Laminar flow over a horizontal, flat plate ( $Re_x < 5 \times 10^5$ ):**

Constant wall temperature:

$$\text{Local Nusselt number, } Nu_x = \left( \frac{h_c x}{k_f} \right) = 0.332 Re_x^{0.5} Pr^{1/3} \quad (7.26)$$

Constant wall heat flux:

$$\text{Local Nusselt number, } Nu_x = \left( \frac{h_c x}{k_f} \right) = 0.453 Re_x^{0.5} Pr^{1/3} \quad (7.27)$$

The average Nusselt number is obtained by integrating local Nusselt number from 0 to L and dividing by L

**d) Turbulent flow over horizontal, flat plate ( $Re_x > 5 \times 10^5$ ):**

Constant wall temperature:

$$\text{Average Nusselt number, } \bar{Nu}_L = \left( \frac{\bar{h}_c L}{k_f} \right) = Pr^{1/3} (0.037 Re_L^{0.8} - 850) \quad (7.28)$$

**e) Free convection over hot, vertical flat plates and cylinders:**

Constant wall temperature:

$$\text{Average Nusselt number, } \bar{Nu}_L = \left( \frac{\bar{h}_c L}{k_f} \right) = c (Gr_L Pr)^n = c Ra_L^n \quad (7.29)$$

where c and n are 0.59 and  $\frac{1}{4}$  for laminar flow ( $10^4 < Gr^L \cdot Pr < 10^9$ ) and 0.10 and  $\frac{1}{3}$  for turbulent flow ( $10^9 < Gr^L \cdot Pr < 10^{13}$ )

In the above equation,  $Gr_L$  is the average Grashoff number given by:

$$\text{Average Grashoff Number } Gr_L = \frac{g\beta (T_w - T_\infty) L^3}{\nu^2} \quad (7.30)$$

where g is the acceleration due to gravity,  $\beta$  is volumetric coefficient of thermal expansion,  $T_w$  and  $T_\infty$  are the plate and the free stream fluid temperatures, respectively and  $\nu$  is the kinematic viscosity.

Constant wall heat flux,  $q_w$ :

$$\text{Local Nusselt number, } Nu_x = \left( \frac{h_c x}{k_f} \right) = 0.60 (Gr_x^* Pr)^{1/5} \quad (7.31)$$

$$\text{where } Gr_x^* = \frac{g\beta q_w x^4}{k_f \nu^2}$$

The above equation is valid for  $10^5 < Gr_x^* \cdot Pr < 10^{11}$

**f) Free convection over horizontal flat plates:**

$$\text{Average Nusselt number, } \bar{Nu}_L = \left( \frac{\bar{h}_c L}{k_f} \right) = c (Gr_L Pr)^n \quad (7.32)$$

The values of c and n are given in Table 7.3 for different orientations and flow regimes.

Table 7.3 Values of c and n

Orientation of plate	Range of $Gr_L Pr$	c	n	Flow regime
Hot surface facing up or cold surface facing down, <b>constant <math>T_w</math></b>	$10^5$ to $2 \times 10^7$	0.54	1/4	Laminar
	$2 \times 10^7$ to $3 \times 10^{10}$	0.14	1/3	Turbulent
Hot surface facing down or cold surface facing up, <b>constant <math>T_w</math></b>	$3 \times 10^5$ to $3 \times 10^{10}$	0.27	1/4	Laminar
Hot surface facing up, <b>constant <math>q_w</math></b>	$< 2 \times 10^8$	0.13	1/3	
	$5 \times 10^8$ to $10^{11}$	0.16	1/3	
Hot surface facing down, <b>constant <math>q_w</math></b>	$10^6$ to $10^{11}$	0.58	1/5	

In the above free convection equations, the fluid properties have to be evaluated at a mean temperature defined as  $T_m = T_w - 0.25(T_w - T_\infty)$ .

**g) Convection heat transfer with phase change:**

Filmwise condensation over horizontal tubes of outer diameter  $D_o$ :

The heat transfer coefficient for film-wise condensation is given by Nusselt's theory that assumes the vapour to be still and at saturation temperature. The mean condensation heat transfer coefficient,  $h_m$  is given by:

$$h_m = 0.725 \left[ \frac{k_f^3 \rho_f^2 g h_{fg}}{ND_o \mu_f \Delta T} \right]^{1/4} \quad (7.33)$$

where, subscript f refers to saturated liquid state, N refers to number of tubes above each other in a column and  $\Delta T = T_r - T_{wo}$ ,  $T_r$  and  $T_{wo}$  being refrigerant and outside wall temperatures respectively.

Filmwise condensation over a vertical plate of length L:

The mean condensation heat transfer coefficient,  $h_m$  is given by,

$$h_m = 0.943 \left[ \frac{k_f^3 \rho_f^2 g h_{fg}}{\mu_f L \Delta T} \right]^{1/4} \quad (7.34)$$

Nucleate pool boiling of refrigerants inside a shell:

$$h_r = C \Delta T^{2 \text{ to } 3} \quad (7.35)$$

where  $\Delta T$  is the temperature difference between surface and boiling fluid and C is a constant that depends on the nature of refrigerant etc.

The correlations for convective heat transfer coefficients given above are only few examples of some of the common situations. A large number of correlations are available for almost all commonly encountered convection problems. The reader should refer to standard text books on heat transfer for further details.

## 7.3. Fundamentals of Mass transfer

When a system contains two or more components whose concentration vary from point to point, there is a natural tendency for mass to be transferred, minimizing the concentration differences within the system. The transport of one constituent from a region of higher concentration to that of lower concentration is called *mass transfer*. A common example of mass transfer is drying of a wet surface exposed to unsaturated air. Refrigeration and air conditioning deal with processes that involve mass transfer. Some basic laws of mass transfer relevant to refrigeration and air conditioning are discussed below.

### 7.3.1. Fick's Law of Diffusion:

This law deals with transfer of mass within a medium due to difference in concentration between various parts of it. This is very similar to Fourier's law of heat conduction as the mass transport is also by molecular diffusion processes. According to this law, rate of diffusion of component A  $\dot{m}_A$  (kg/s) is proportional to the concentration gradient and the area of mass transfer, i.e.

$$\dot{m}_A = -D_{AB}A \frac{dc_A}{dx} \quad (7.36)$$

where,  $D_{AB}$  is called diffusion coefficient for component A through component B, and it has the units of  $m^2/s$  just like those of thermal diffusivity  $\alpha$  and the kinematic viscosity of fluid  $\nu$  for momentum transfer.

### 7.3.2. Convective mass transfer:

Mass transfer due to convection involves transfer of mass between a moving fluid and a surface or between two relatively immiscible moving fluids. Similar to convective heat transfer, this mode of mass transfer depends on the transport properties as well as the dynamic characteristics of the flow field. Similar to Newton's law for convective heat transfer, the convective mass transfer equation can be written as:

$$\dot{m} = h_m A \Delta c_A \quad (7.37)$$

where  $h_m$  is the convective mass transfer coefficient and  $\Delta c_A$  is the difference between the boundary surface concentration and the average concentration of fluid stream of the diffusing species A.

Similar to convective heat transfer, convective mass transfer coefficient depends on the type of flow, i.e., laminar or turbulent and forced or free. In general the mass transfer coefficient is a function of the system geometry, fluid and flow properties and

the concentration difference. Similar to momentum and heat transfers, concentration boundary layers develop whenever mass transfer takes place between a surface and a fluid. This suggests analogies between mass, momentum and energy transfers. In convective mass transfer the non-dimensional numbers corresponding to Prandtl and Nusselt numbers of convective heat transfer are called as Schmidt and Sherwood numbers. These are defined as:

$$\text{Sherwood number, } Sh_L = \frac{h_m L}{D} \quad (7.38)$$

$$\text{Schmidt number, } Sc = \frac{\nu}{D} \quad (7.39)$$

where  $h_m$  is the convective mass transfer coefficient,  $D$  is the diffusivity and  $\nu$  is the kinematic viscosity.

The general convective mass transfer correlations relate the Sherwood number to Reynolds and Schmidt number.

## 7.4. Analogy between heat, mass and momentum transfer

### 7.4.1. Reynolds and Colburn Analogies

The boundary layer equations for momentum for a flat plate are exactly same as those for energy equation if Prandtl number,  $Pr = 1$ , pressure gradient is zero and viscous dissipation is negligible, there are no heat sources and for similar boundary conditions. Hence, the solution for non-dimensional velocity and temperature are also same. It can be shown that for such a case,

$$\text{Stanton number, } St = \left( \frac{Nu}{Re.Pr} \right) = \left( \frac{h_c}{\rho V c_p} \right) = \frac{f}{2} \quad (7.40)$$

where  $f$  is the friction factor and  $St$  is Stanton Number. The above equation, which relates heat and momentum transfers is known as Reynolds analogy.

To account for the variation in Prandtl number in the range of 0.6 to 50, the Reynolds analogy is modified resulting in Colburn analogy, which is stated as follows.

$$St.Pr^{2/3} = \frac{f}{2} \quad (7.41)$$

### 7.4.2. Analogy between heat, mass and momentum transfer

The role that thermal diffusivity plays in the energy equation is played by diffusivity  $D$  in the mass transfer equation. Therefore, the analogy between momentum and mass transfer for a flat plate will yield:

$$\frac{Sh}{Re.Sc} = \left( \frac{h_m L}{D} \right) \left( \frac{\nu}{VL} \right) \left( \frac{D}{\nu} \right) = \left( \frac{h_m}{V} \right) = \left( \frac{f}{2} \right) \quad (7.42)$$

To account for values of Schmidt number different from one, following correlation is introduced,

$$\frac{Sh}{Re.Sc} Sc^{2/3} = \frac{f}{2} \quad (7.43)$$

Comparing the equations relating heat and momentum transfer with heat and mass transfer, it can be shown that,

$$\left( \frac{h_c}{\rho c_p h_m} \right) = \left( \frac{\alpha}{D} \right)^{2/3} \quad (7.44)$$

This analogy is followed in most of the chemical engineering literature and  $\alpha/D$  is referred to as Lewis number. In air-conditioning calculations, for convenience Lewis number is defined as:

$$\text{Lewis number, } Le = \left( \frac{\alpha}{D} \right)^{2/3} \quad (7.45)$$

The above analogies are very useful as by applying them it is possible to find heat transfer coefficient if friction factor is known and mass transfer coefficient can be calculated from the knowledge of heat transfer coefficient.

## 7.5. Multimode heat transfer

In most of the practical heat transfer problems heat transfer occurs due to more than one mechanism. Using the concept of thermal resistance developed earlier, it is possible to analyze steady state, multimode heat transfer problems in a simple manner, similar to electrical networks. An example of this is transfer of heat from outside to the interiors of an air conditioned space. Normally, the walls of the air conditioned rooms are made up of different layers having different heat transfer properties. Once again the concept of thermal resistance is useful in analyzing the heat transfer through multilayered walls. The example given below illustrates these principles.

### Multimode heat transfer through a building wall:

The schematic of a multimode heat transfer building wall is shown in Fig. 7.3. From the figure it can be seen that:

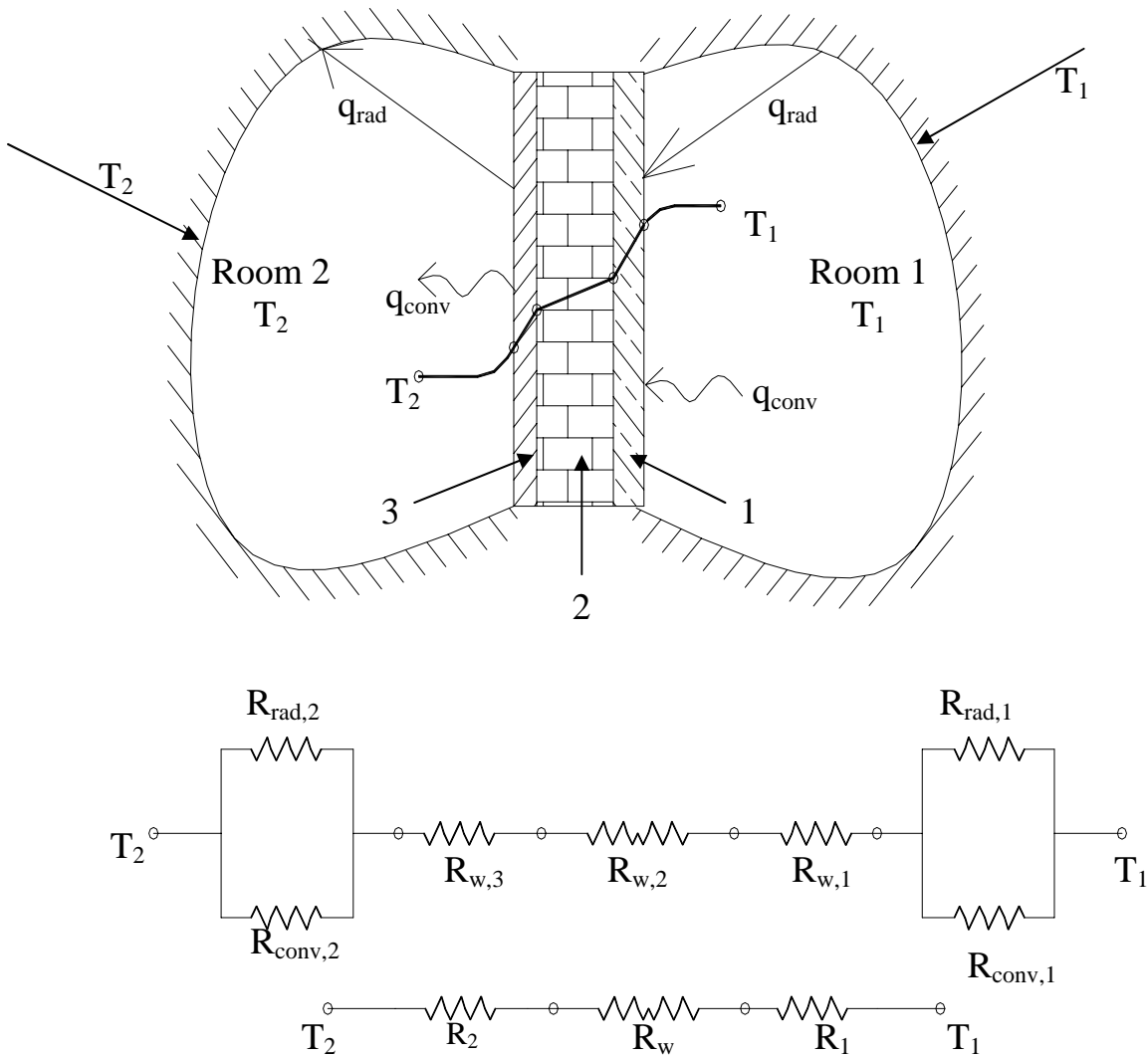
$$Q_{1-2} = \frac{(T_1 - T_2)}{R_{\text{total}}} \quad (7.46a)$$

$$R_{\text{total}} = \left( \frac{R_{\text{conv},2} R_{\text{rad},2}}{R_{\text{conv},2} + R_{\text{rad},2}} \right) + (R_{w,3} + R_{w,2} + R_{w,1}) + \left( \frac{R_{\text{conv},1} R_{\text{rad},1}}{R_{\text{conv},1} + R_{\text{rad},1}} \right) \quad (7.46b)$$

$$R_{\text{total}} = (R_2) + (R_w) + (R_1) \quad (7.46c)$$

$$Q_{1-2} = UA(T_1 - T_2) \quad (7.46d)$$

where, overall heat transfer coefficient,  $U = \frac{1}{R_{\text{total}}A}$



**Fig. 7.3.** Schematic of a multimode heat transfer building wall

**Composite cylinders:**

The concept of resistance networks is also useful in solving problems involving composite cylinders. A common example of this is steady state heat transfer through an insulated pipe with a fluid flowing inside. Since it is not possible to perfectly insulate the pipe, heat transfer takes place between the surroundings and the inner fluid when they are at different temperatures. For such cases the heat transfer rate is given by:

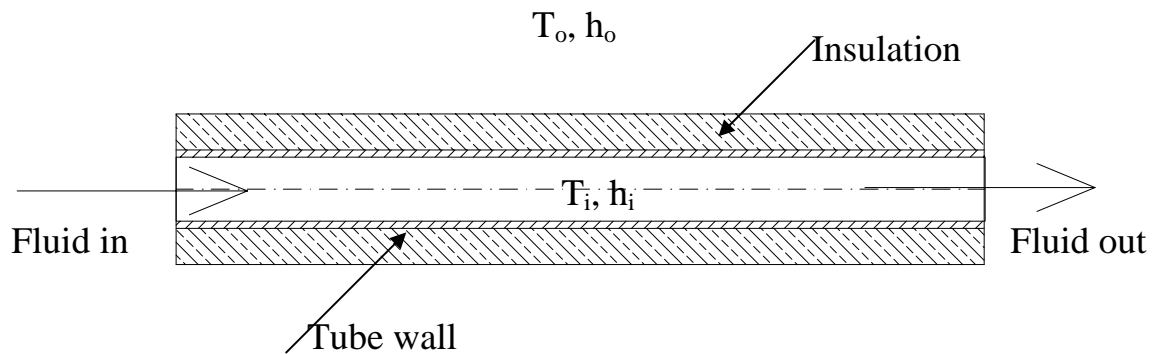
$$Q = U_o A_o (T_i - T_o) \tag{7.47}$$



where  $A_o$  is the outer surface area of the composite cylinder and  $U_o$  is the overall heat transfer coefficient with respect to the outer area given by:

$$\frac{1}{U_o A_o} = \frac{1}{h_i A_i} + \frac{\ln(r_2/r_1)}{2\pi L k_m} + \frac{\ln(r_3/r_2)}{2\pi L k_{in}} + \frac{1}{h_o A_o} \quad (7.48)$$

In the above equation,  $h_i$  and  $h_o$  are the inner and outer convective heat transfer coefficients,  $A_i$  and  $A_o$  are the inner and outer surface areas of the composite cylinder,  $k_m$  and  $k_{in}$  are the thermal conductivity of tube wall and insulation,  $L$  is the length of the cylinder,  $r_1$ ,  $r_2$  and  $r_3$  are the inner and outer radii of the tube and outer radius of the insulation respectively. Additional heat transfer resistance has to be added if there is any scale formation on the tube wall surface due to fouling.



*Fig. 7.4. Composite cylindrical tube*

## 7.6. Heat exchangers:

A heat exchanger is a device in which heat is transferred from one fluid stream to another across a solid surface. Thus a typical heat exchanger involves both conduction and convection heat transfers. A wide variety of heat exchangers are extensively used in refrigeration and air conditioning. In most of the cases the heat exchangers operate in a steady state, hence the concept of thermal resistance and overall heat transfer coefficients can be used very conveniently. In general, the temperatures of the fluid streams may vary along the length of the heat exchanger. To take care of the temperature variation, the concept of Log Mean Temperature Difference (LMTD) is introduced in the design of heat exchangers. It is defined as:

$$LMTD = \frac{\Delta T_1 - \Delta T_2}{\ln(\Delta T_1 / \Delta T_2)} \quad (7.49)$$

where  $\Delta T_1$  and  $\Delta T_2$  are the temperature difference between the hot and cold fluid streams at two inlet and outlet of the heat exchangers.

If we assume that the overall heat transfer coefficient does not vary along the length, and specific heats of the fluids remain constant, then the heat transfer rate is given by:

$$Q = U_o A_o (\text{LMTD}) = U_o A_o \left( \frac{\Delta T_1 - \Delta T_2}{\ln(\Delta T_1 / \Delta T_2)} \right)$$

also

$$Q = U_i A_i (\text{LMTD}) = U_i A_i \left( \frac{\Delta T_1 - \Delta T_2}{\ln(\Delta T_1 / \Delta T_2)} \right) \quad (7.50)$$

the above equation is valid for both parallel flow (both the fluids flow in the same direction) or counterflow (fluids flow in opposite directions) type heat exchangers. For other types such as cross-flow, the equation is modified by including a multiplying factor. The design aspects of heat exchangers used in refrigeration and air conditioning will be discussed in later chapters.

### Questions:

1. Obtain an analytical expression for temperature distribution for a plane wall having uniform surface temperatures of  $T_1$  and  $T_2$  at  $x_1$  and  $x_2$  respectively. It may be mentioned that the thermal conductivity  $k = k_0 (1+bT)$ , where  $b$  is a constant. ([Solution](#))

2. A cold storage room has walls made of 0.3 m of brick on outside followed by 0.1 m of plastic foam and a final layer of 5 cm of wood. The thermal conductivities of brick, foam and wood are 1, 0.02 and 0.2 W/mK respectively. The internal and external heat transfer coefficients are 40 and 20 W/m<sup>2</sup>K. The outside and inside temperatures are 40<sup>0</sup>C and -10<sup>0</sup>C. Determine the rate of cooling required to maintain the temperature of the room at -10<sup>0</sup>C and the temperature of the inside surface of the brick given that the total wall area is 100 m<sup>2</sup>. ([Solution](#))

3. A steel pipe of negligible thickness and having a diameter of 20 cm has hot air at 100<sup>0</sup>C flowing through it. The pipe is covered with two layers of insulating materials each having a thickness of 10 cm and having thermal conductivities of 0.2 W/mK and 0.4 W/mK. The inside and outside heat transfer coefficients are 100 and 50 W/m<sup>2</sup>K respectively. The atmosphere is at 35<sup>0</sup>C. Calculate the rate of heat loss from a 100 m long pipe. ([Solution](#))

4. Water flows inside a pipe having a diameter of 10 cm with a velocity of 1 m/s. the pipe is 5 m long. Calculate the heat transfer coefficient if the mean water temperature is at 40<sup>0</sup>C and the wall is isothermal at 80<sup>0</sup>C. ([Solution](#))

5. A long rod having a diameter of 30 mm is to be heated from 400<sup>0</sup>C to 600<sup>0</sup>C. The material of the rod has a density of 8000 kg/m<sup>3</sup> and specific heat of 400 J/kgK. It is placed concentrically inside a long cylindrical furnace having an internal diameter of 150 mm. The inner side of the furnace is at a temperature of 1100<sup>0</sup>C and has an

emissivity of 0.7. If the surface of the rod has an emissivity of 0.5, find the time required to heat the rod. ([Solution](#))

6. Air flows over a flat plate of length 0.3 m at a constant temperature. The velocity of air at a distance far off from the surface of the plate is 50 m/s. Calculate the average heat transfer coefficient from the surface considering separate laminar and turbulent sections and compare it with the result obtained by assuming fully turbulent flow. ([Solution](#))

Note: The local Nusselt number for laminar and turbulent flows is given by:

$$\text{laminar : } Nu_x = 0.331 Re_x^{1/2} Pr^{1/3}$$

$$\text{turbulent: } Nu_x = 0.0288 Re_x^{0.8} Pr^{1/3}$$

Transition occurs at  $Re_{x,trans} = 2 \times 10^5$ . The forced convection boundary layer flow begins as laminar and then becomes turbulent. Take the properties of air to be  $\rho = 1.1 \text{ kg/m}^3$ ,  $\mu = 1.7 \times 10^{-5} \text{ kg/m s}$ ,  $k = 0.03 \text{ W/mK}$  and  $Pr = 0.7$ .

7. A vertical tube having a diameter of 80 mm and 1.5 m in length has a surface temperature of  $80^\circ\text{C}$ . Water flows inside the tube while saturated steam at 2 bar condenses outside. Calculate the heat transfer coefficient. ([Solution](#))

Note: Properties of saturated steam at 2 bar:  $T_{sat} = 120.2^\circ\text{C}$ ,  $h_{fg} = 2202 \text{ kJ/kgK}$ ,  $\rho = 1.129 \text{ kg/m}^3$ ; For liquid phase at  $100^\circ\text{C}$ :  $\rho_L = 958 \text{ kg/m}^3$ ,  $c_p = 4129 \text{ J/kgK}$ ,  $\mu_L = 0.279 \times 10^{-3} \text{ kg/m s}$  and  $Pr = 1.73$ .

8. Air at 300 K and at atmospheric pressure flows at a mean velocity of 50 m/s over a flat plate 1 m long. Assuming the concentration of vapour in air to be negligible, calculate the mass transfer coefficient of water vapour from the plate into the air. The diffusion of water vapour into air is  $0.5 \times 10^{-4} \text{ m}^2/\text{s}$ . The Colburn j-factor for heat transfer coefficient is given by  $j_H = 0.0296 Re^{-0.2}$ . ([Solution](#))

9. An oil cooler has to cool oil flowing at 20 kg/min from  $100^\circ\text{C}$  to  $50^\circ\text{C}$ . The specific heat of the oil is  $2000 \text{ J/kg K}$ . Water with similar flow rate at an ambient temperature of  $35^\circ\text{C}$  is used to cool the oil. Should we use a parallel flow or a counter flow heat exchanger? Calculate the surface area of the heat exchanger if the external heat transfer coefficient is  $100 \text{ W/m}^2\text{K}$ . ([Solution](#))

# Lesson

8

## Methods of producing Low Temperatures

## The specific objectives of the lesson :

In this lesson the basic concepts applicable to refrigeration is introduced. This chapter presents the various methods of producing low temperatures, viz. Sensible cooling by cold medium, Endothermic mixing of substances, Phase change processes, Expansion of liquids, Expansion of gases, Thermoelectric refrigeration, Adiabatic demagnetization. At the end of this lesson students should be able to:

1. Define refrigeration (*Section 8.1*)
2. Express clearly the working principles of various methods to produce low temperatures (*Section 8.2*)

### 8.1. Introduction

Refrigeration is defined as “the process of cooling of bodies or fluids to temperatures lower than those available in the surroundings at a particular time and place”. It should be kept in mind that refrigeration is not same as “cooling”, even though both the terms imply a decrease in temperature. In general, cooling is a heat transfer process down a temperature gradient, it can be a natural, spontaneous process or an artificial process. However, refrigeration is not a spontaneous process, as it requires expenditure of exergy (or availability). Thus cooling of a hot cup of coffee is a spontaneous cooling process (not a refrigeration process), while converting a glass of water from room temperature to say, a block of ice, is a refrigeration process (non-spontaneous). “All refrigeration processes involve cooling, but all cooling processes need not involve refrigeration”.

Refrigeration is a much more difficult process than heating, this is in accordance with the second laws of thermodynamics. This also explains the fact that people knew ‘how to heat’, much earlier than they learned ‘how to refrigerate’. All practical refrigeration processes involve reducing the temperature of a system from its initial value to the required temperature that is lower than the surroundings, and then maintaining the system at the required low temperature. The second part is necessary due to the reason that once the temperature of a system is reduced, a potential for heat transfer is created between the system and surroundings, and in the absence of a “perfect insulation” heat transfer from the surroundings to the system takes place resulting in increase in system temperature. In addition, the system itself may generate heat (e.g. due to human beings, appliances etc.), which needs to be extracted continuously. Thus in practice refrigeration systems have to first reduce the system temperature and then extract heat from the system at such a rate that the temperature of the system remains low. Theoretically refrigeration can be achieved by several methods. All these methods involve producing temperatures low enough for heat transfer to take place from the system being refrigerated to the system that is producing refrigeration.

### 8.2. Methods of producing low temperatures

#### 8.2.1. Sensible cooling by cold medium

If a substance is available at a temperature lower than the required refrigeration temperature, then it can be used for sensible cooling by bringing it in thermal contact with the system to be refrigerated. For example, a building can be cooled to a temperature lower than the

surroundings by introducing cold air into the building. Cold water or brine is used for cooling beverages, dairy products and in other industrial processes by absorbing heat from them. The energy absorbed by the substance providing cooling increases its temperature, and the heat transferred during this process is given by:

$$Q = mc_p (\Delta T) \quad (8.1)$$

Where  $m$  is the mass of the substance providing cooling,  $c_p$  is its specific heat and  $\Delta T$  is the temperature rise undergone by the substance. Since the temperature of the cold substance increases during the process, to provide continuous refrigeration, a continuous supply of the cold substance should be maintained, which may call for an external refrigeration cycle.

### 8.2.2. Endothermic mixing of substances

This is one of the oldest methods known to mankind. It is very well-known that low temperatures can be obtained when certain salts are dissolved in water. This is due to the fact that dissolving of these salts in water is an endothermic process, i.e., heat is absorbed from the solution leading to its cooling. For example, when salts such as sodium nitrate, sodium chloride, calcium chloride added to water, its temperature falls. By dissolving sodium chloride in water, it is possible to achieve temperatures as low as  $-21^{\circ}\text{C}$ , while with calcium chloride a temperature of  $-51^{\circ}\text{C}$  could be obtained. However, producing low temperature by endothermic mixing has several practical limitations. These are: the refrigeration effect obtained is very small (the refrigeration effect depends on the heat of solution of the dissolved substance, which is typically small for most of the commonly used salts), and recovery of the dissolved salt is often uneconomical as this calls for evaporation of water from the solution.

### 8.2.3. Phase change processes

Refrigeration is produced when substances undergo endothermic phase change processes such as sublimation, melting and evaporation. For example, when ice melts it produces a refrigeration effect in the surroundings by absorbing heat. The amount of refrigeration produced and the temperature at which refrigeration is produced depends on the substance undergoing phase change. It is well-known that pure water ice at 1 atmospheric pressure melts at a temperature of about  $0^{\circ}\text{C}$  and extracts about 335 kJ/kg of heat from the surroundings. At 1 atmospheric pressure, dry ice (solid carbon dioxide) undergoes sublimation at a temperature of  $-78.5^{\circ}\text{C}$ , yielding a refrigeration effect of 573 kJ/kg. Both water ice and dry ice are widely used to provide refrigeration in several applications. However, evaporation or vaporization is the most commonly used phase change process in practical refrigeration systems as it is easier to handle fluids in cyclic devices. In these systems, the working fluid (refrigerant) provides refrigeration effect as it changes its state from liquid to vapor in the evaporator.

For all phase change processes, the amount of refrigeration produced is given by:

$$Q = m(\Delta h_{ph}) \quad (8.2)$$

where  $Q$  is the refrigeration produced (heat transferred),  $m$  is the mass of the phase change substance and  $\Delta h_{ph}$  is the latent heat of phase change. If the process is one of evaporation,

then  $\Delta h_{ph}$  is the latent heat of vaporization (difference between saturated vapour enthalpy and saturated liquid enthalpy at a given pressure). From the above equation it can be seen that substances having large latent heats require less amount of substance ( $m$ ) and vice versa. Apart from the latent heat, the temperature at which the phase change occurs is also important. For liquid-to-vapour phase change, the Normal Boiling Point (NBP) is a good indication of the usefulness of a particular fluid for refrigeration applications. The Normal Boiling Point is defined as the temperature at which the liquid and vapour are in equilibrium at a pressure of 1 atm. The latent heat of vaporization and normal boiling point are related by the Trouton's rule, which states that the molar entropy of vaporization is constant for all fluids at normal boiling point. This can be expressed mathematically as:

$$\Delta \bar{s}_{fg} = \frac{\Delta \bar{h}_{fg}}{T_b} = 85 \text{ to } 110 \text{ J/mol.K} \quad (8.3)$$

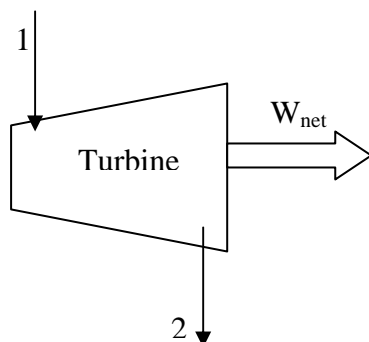
where  $\Delta s_{fg}$  is the molar entropy of vaporization (J/mol.K),  $\Delta h_{fg}$  is the molar enthalpy of vaporization (J/mol) and  $T_b$  is the normal boiling point in K. The above equation shows that higher the NBP, higher will be the molar enthalpy of vaporization. It can also be inferred from the above equation that low molecular weight fluids have higher specific enthalpy of vaporization and vice versa.

The fluids used in a refrigeration system should preferably have a low NBP such that they vaporize at sufficiently low temperatures to produce refrigeration, however, if the NBP is too low then the operating pressures will be very high. The Clausius-Clayperon equation relates the vapour pressures with temperature, and is given by:

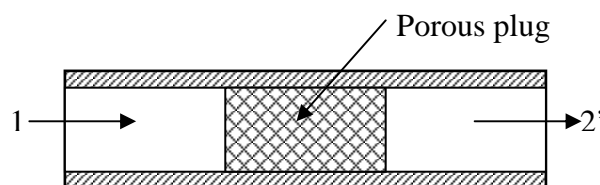
$$\left( \frac{d \ln p}{dT} \right)_{\text{sat}} = \frac{\Delta h_{fg}}{RT^2} \quad (8.4)$$

The Clausius-Clapeyron equation is based on the assumptions that the specific volume of liquid is negligible in comparison with the specific volume of the vapour and the vapour obeys ideal gas law. Clausius-Clapeyron equation is useful in estimating the latent heat of vaporization (or sublimation) from the saturated pressure-temperature data.

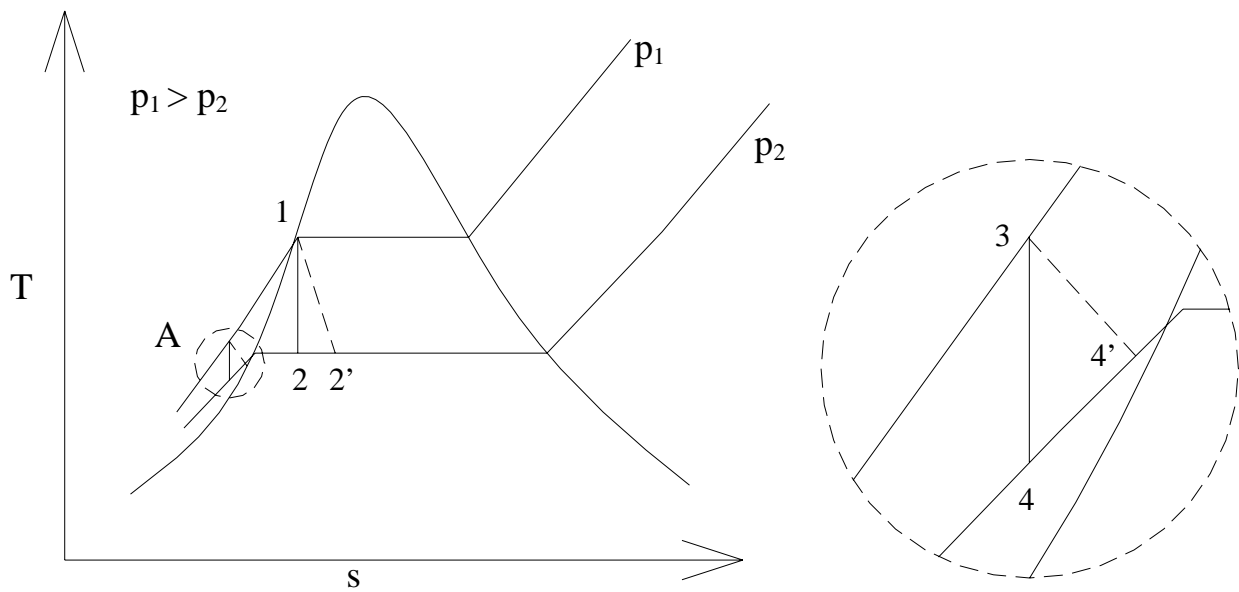
### 8.2.4. Expansion of Liquids



**Fig.8.1(a).** Expansion through a turbine



**Fig.8.1(b).** Isenthalpic Expansion through a porous plug



**Fig.8.2(a).** Expansion of saturated liquid  
1-2: Isentropic; 1-2': Isenthalpic

**Fig.8.2(b).** Expansion of subcooled liquid  
3-4: Isentropic; 3-4': Isenthalpic

When a high pressure liquid flows through a turbine delivering a net work output (Fig.8.1(a)), its pressure and enthalpy fall. In an ideal case, the expansion process can be isentropic, so that its entropy remains constant and the drop in enthalpy will be equal to the specific work output (neglecting kinetic and potential energy changes). When a high pressure liquid is forced to flow through a restriction such as a porous plug (Fig.8.1 (b)), its pressure decreases due to frictional effects. No net work output is obtained, and if the process is adiabatic and change in potential and kinetic energies are negligible, then from steady flow energy equation, it can be easily shown that the enthalpy of the liquid remains constant. However, since the process is highly irreversible, entropy of liquid increases during the process. This process is called as a *throttling process*. Whether or not the temperature of the liquid drops significantly during the isentropic and isenthalpic expansion processes depends on the inlet condition of the liquid. If the inlet is a saturated liquid (state 1 in Fig. 8.2(a)), then the outlet condition lies in the two-phase region, i.e., at the outlet there will be some amount of vapour in addition to the liquid for both isentropic expansion through the turbine as well as isenthalpic process through the porous plug. These processes 1-2 and 1-2', respectively are shown on a T-s diagram in Fig. 8.2 (a). Obviously, from energy balance it can be shown that in isentropic expansion through a turbine with a net work output, the enthalpy at state 2 will be less than enthalpy at state 1, and in case of isenthalpic expansion through porous plug (with no work output), the entropy at state 2' will be greater than the entropy at state 1. For both the cases the exit temperature will be same, which is equal to the saturation temperature corresponding to the outlet pressure p<sub>2</sub>. It can be seen that this temperature is much lower than the inlet temperature (saturation temperature corresponding to the inlet pressure p<sub>1</sub>). This large temperature drop is a result of vapour generation during expansion requiring enthalpy of vaporization, which in the absence of external heat transfer (adiabatic) has to be supplied by the fluid itself.



On the contrary, if the liquid at inlet is subcooled to such an extent that when it expands from the same inlet pressure  $p_1$  to the same outlet pressure  $p_2$ , the exit condition is in a liquid state, we observe that the temperature drop obtained is much smaller, i.e.,  $(T_3 - T_{4,4'}) \ll (T_1 - T_{2,2'})$  for both isentropic as well as isenthalpic processes. The temperature drop obtained during isenthalpic expansion is less than that of isentropic expansion. Thus in refrigeration systems which use expansion of liquids to produce low temperatures (e.g. vapour compression refrigeration systems), the inlet state of the liquid is always such that the outlet falls into the two phase region.

### 8.2.5. Expansion of gases

#### a) By throttling:

Similar to liquids, gases can also be expanded from high pressure to low pressure either by using a turbine (isentropic expansion) or a throttling device (isenthalpic process). Similar to throttling of liquids, the throttling of gases is also an isenthalpic process. Since the enthalpy of an ideal gas is a function of temperature only, during an isenthalpic process, the temperature of the ideal gas remains constant. In case of real gases, whether the temperature decreases or increases during the isenthalpic throttling process depends on a property of the gas called Joule-Thomson coefficient,  $\mu_{JT}$ , given by:

$$\mu_{JT} = \left( \frac{\partial T}{\partial p} \right)_h \quad (8.5)$$

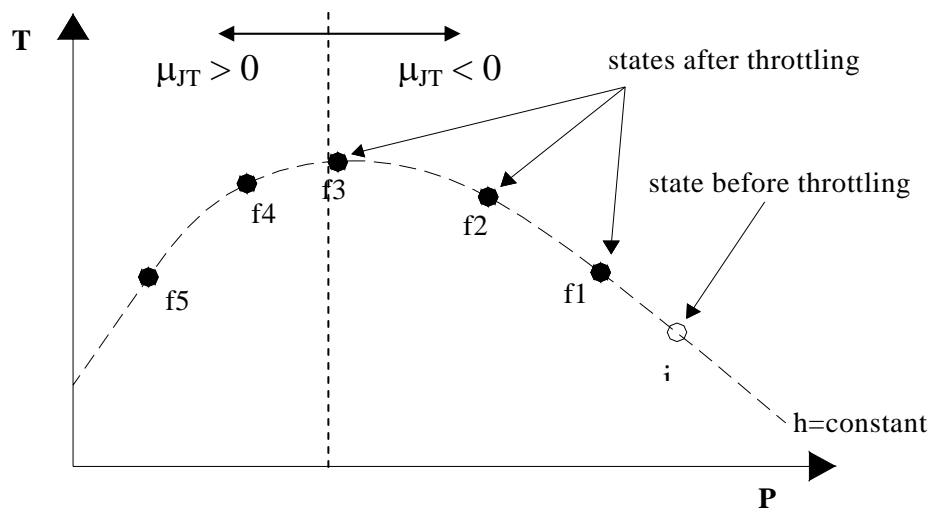
from thermodynamic relations it can be shown that the Joule-Thomson coefficient,  $\mu_{JT}$ , is equal to:

$$\mu_{JT} = \frac{\left[ T \left( \frac{\partial v}{\partial T} \right)_p - v \right]}{c_p} \quad (8.6)$$

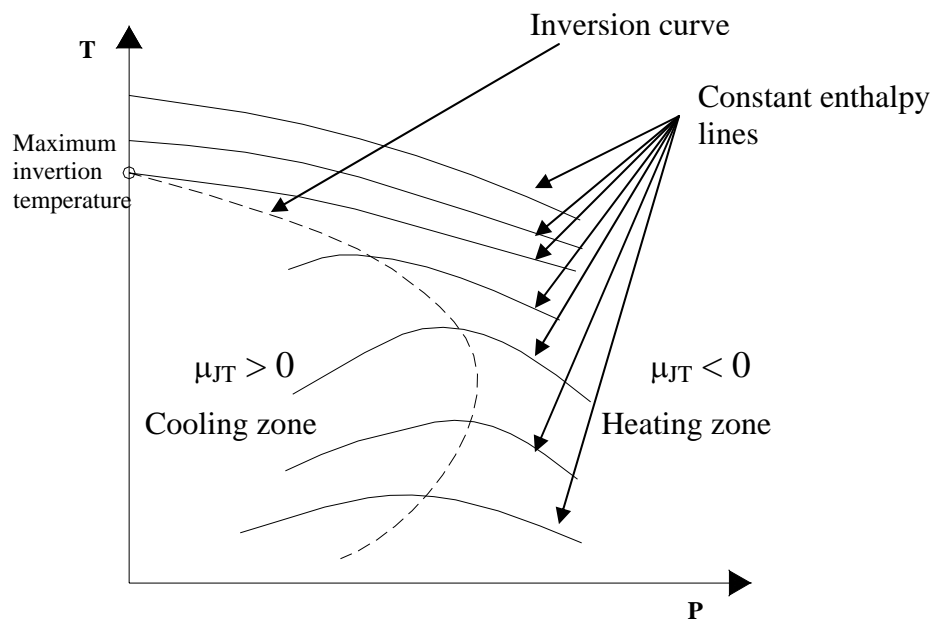
where 'v' is the specific volume and  $c_p$  is the specific heat at constant pressure. From the above expression, it can be easily shown that  $\mu_{JT}$  is zero for ideal gases ( $pv = RT$ ). Thus the magnitude of  $\mu_{JT}$  is a measure of deviation of real gases from ideal behaviour. From the definition of  $\mu_{JT}$ , the temperature of a real gas falls during isenthalpic expansion if  $\mu_{JT}$  is positive, and it increases when  $\mu_{JT}$  is negative. Figure 8.3 shows the process of isenthalpic expansion on temperature-pressure coordinates.

As shown in Fig. 8.3, along a constant enthalpy line (isenthalpic process), beginning with an initial state 'i' the temperature of the gas increases initially with reduction in pressure upto point f3, and  $\mu_{JT} = \left( \frac{\partial T}{\partial p} \right)_h$  is negative from point i to point f3. However, further reduction in pressure from point f3 to f5, results in a reduction of temperature from f3 to f5. Thus point f3 represents a point of inflexion, where  $\mu_{JT} = \left( \frac{\partial T}{\partial p} \right)_h = 0$ . The temperature at the point of inflexion is known as *inversion temperature* for the given enthalpy. Therefore, if the initial

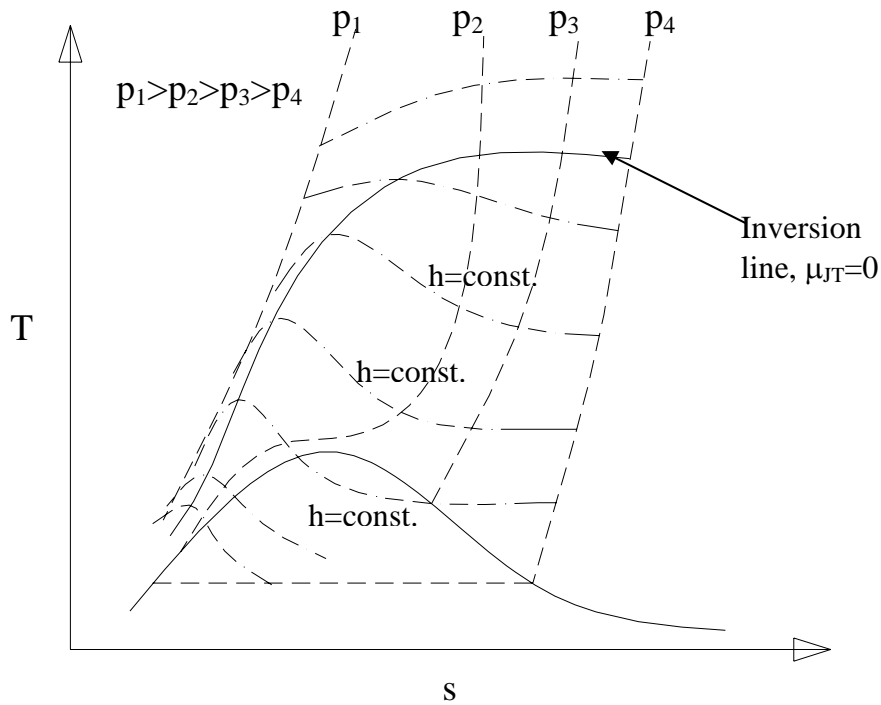
condition falls on the left of inversion temperature, the gas undergoes a reduction in temperature during expansion and if the initial condition falls on the right side of inversion point, then temperature increases during expansion. Figure 8.4 shows several isenthalpic lines on T-p coordinates. Also shown in the figure is an inversion curve, which is the locus of all the inversion points. The point where the inversion curve intercepts the temperature axis is called as maximum inversion temperature. For any gas, the temperature will reduce during throttling only when the initial temperature is lower than the maximum inversion temperature. For most of the gases (with the exception of neon, helium, hydrogen) the maximum inversion temperature is much above the room temperature, hence isenthalpic expansion of these gases can lead to their cooling.



**Fig.8.3.** Isenthalpic expansion of a gas on T-P coordinates



**Fig.8.4.** Isenthalpic lines on T-P coordinates



**Fig.8.5.** Inversion temperature line on T-s diagram

Figure 8.5 shows the inversion temperature line on T-s diagram. Several things can be observed from the diagram. At high temperatures (greater than inversion temperature), throttling increases temperature. Maximum temperature drop during throttling occurs when the initial state lies on the inversion curve. Throttling at low pressures (e.g.  $p_3$  to  $p_4$ ) produces smaller reduction in temperature compared to throttling at high pressures (e.g.  $p_2$  to  $p_3$ ). For a given pressure drop during throttling, the drop in temperature is higher at lower temperatures compared to higher temperatures. Gases cannot be liquefied by throttling (i.e., exit condition will not be in two phase region), unless the temperature of the gas is first lowered sufficiently. This fact is very important in the liquefaction of gases. In order to liquefy these gases, they have to be first compressed to high pressures, cooled isobarically to low temperatures and then throttled, so that at the exit a mixture of liquid and vapour can be produced.

#### **b) Expansion of gases through a turbine:**

Steady flow expansion of a high pressure gas through a turbine or an expansion engine results in a net work output with a resulting decrease in enthalpy. This decrease in enthalpy leads to a decrease in temperature. In an ideal case, the expansion will be reversible adiabatic, however, in an actual case, the expansion can be adiabatic but irreversibility exists due to fluid friction. Similar to the case of liquids, it can be shown from the steady flow energy equation that expansion with a net work output reduces the exit enthalpy and hence temperature of the gas. If the changes in potential and kinetic energy are negligible and the process is adiabatic, then:

$$w_{\text{net}} = (h_1 - h_2) \quad (8.7)$$

Since  $w_{\text{net}}$  is positive, the outlet enthalpy  $h_2$  is less than inlet enthalpy  $h_1$ ; hence the outlet temperature  $T_2$  will also be less than inlet temperature  $T_1$ . Unlike isenthalpic expansion, an approximately reversible adiabatic expansion with a net work output always produces a decrease in temperature irrespective of the initial temperature. However, one disadvantage with adiabatic expansion through a turbine/expansion engine is that the temperature drop decreases as the temperature decreases. Hence in practice a combination of adiabatic expansion followed by isenthalpic expansion is used to liquefy gases. The adiabatic expansion is used to pre-cool the gas to a temperature lower than the inversion temperature and then throttling is used to produce liquid. This method was first used by Kapitza to liquefy helium (maximum inversion temperature: 43 K). In practical systems efficient heat exchangers are used to cool the incoming gas by the outgoing gas.

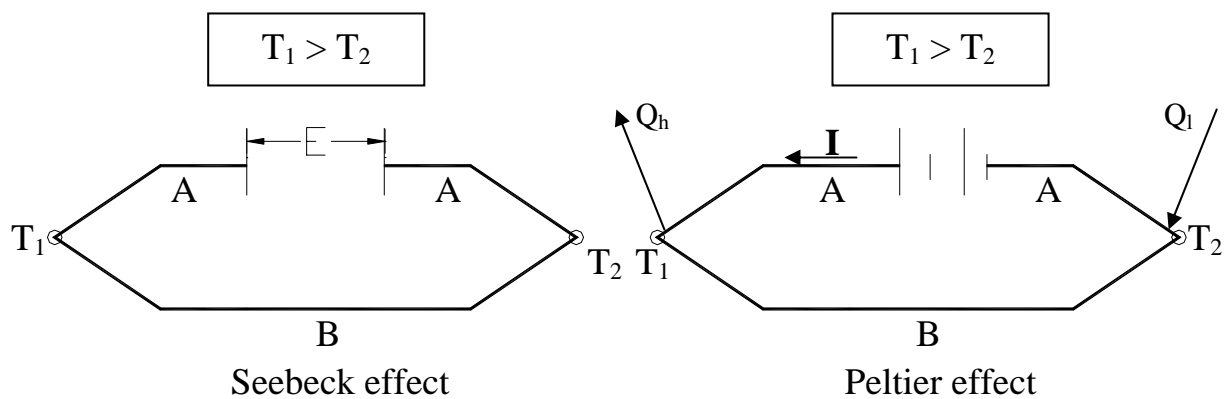
### 8.2.6. Thermoelectric Refrigeration

Thermoelectric refrigeration is a novel method of producing low temperatures and is based on the reverse Seebeck effect. Figure 8.6 shows the illustration of Seebeck and Peltier effects. As shown, in Seebeck effect an EMF,  $E$  is produced when the junctions of two dissimilar conductors are maintained at two different temperatures  $T_1$  and  $T_2$ . This principle is used for measuring temperatures using thermocouples. Experimental studies show that Seebeck effect is reversible. The electromotive force produced is given by:

$$E = \alpha(T_1 - T_2) \quad (8.8)$$

where  $\alpha$  is the *thermoelectric power* or *Seebeck coefficient*. For a constant cold junction temperature ( $T_2$ ),

$$\alpha = \frac{dE}{dT} \quad (8.9)$$



*Fig.8.6. Illustration of Seebeck and Peltier effects*

If a closed circuit is formed by the conductors, then an electrical current,  $I$  flows due to the emf and this would result in irreversible generation of heat ( $q_{\text{ir}} = I^2 R$ ) due to the finite resistance  $R$  of the conductors. This effect is known as *Joule Effect*.

Due to different temperatures  $T_1$  and  $T_2$  ( $T_1 > T_2$ ), there will be heat transfer by conduction also. This is also irreversible and is called as *conduction effect*. The amount of heat transfer depends on the overall thermal conductance of the circuit.

When a battery is added in between the two conductors A and B whose junctions are initially at same temperature, and a current is made to flow through the circuit, the junction temperatures will change, one junction becoming hot ( $T_1$ ) and the other becoming cold ( $T_2$ ). This effect is known as Peltier effect. Refrigeration effect is obtained at the cold junction and heat is rejected to the surroundings at the hot junction. This is the basis for *thermoelectric refrigeration systems*. The position of hot and cold junctions can be reversed by reversing the direction of current flow. The heat transfer rate at each junction is given by:

$$\dot{Q} = \phi I \quad (8.10)$$

where  $\phi$  is the Peltier coefficient in volts and  $I$  is the current in amperes.

When current is passed through a conductor in which there is an initial uniform temperature gradient, then it is observed that the temperature distribution gets distorted as heat transfer takes place. This effect is known as *Thomson effect*. The heat transfer rate per unit length (W/cm) due to Thomson effect is given by:

$$Q_\tau = \tau I \frac{dT}{dx} \quad (8.11)$$

where  $\tau$  is the Thomson coefficient (volts per K),  $I$  is the current (amperes) and  $(dT/dx)$  is the temperature gradient in the conductor (K/cm).

It has been shown from thermodynamic analysis that the Seebeck, Peltier and Thomson coefficients are related by the equations:

$$\phi_{AB} = (\phi_A - \phi_B) = \alpha_{AB} T = (\alpha_A - \alpha_B) T \quad (8.12a)$$

$$\frac{\tau_A - \tau_B}{T} = \frac{d(\alpha_A - \alpha_B)}{dT} \quad (8.12b)$$

where  $\phi_A$ ,  $\alpha_A$  and  $\tau_A$  are the Peltier, Seebeck and Thomson coefficients for material A and  $\phi_B$ ,  $\alpha_B$  and  $\tau_B$  are the Peltier, Seebeck and Thomson coefficients for material B, respectively. The Thomson coefficient becomes zero if the thermoelectric power  $\alpha_{AB}$  remains constant. From the above equations it is seen that the heat transfer rate due to Peltier effect is;

$$\dot{Q} = \phi_{AB} I = \alpha_{AB} IT \quad (8.13)$$

The above equation shows that in order to have high heat transfer rates at low temperatures, either  $\alpha_{AB}$  should be high and/or high currents should be used. However, high currents lead to high heat generation due to the Joulean effect.

Since the coefficients are properties of conducting materials, selection of suitable material is very important in the design of efficient thermoelectric refrigeration systems. Ideal thermoelectric materials should have high electrical conductivity and low thermal

conductivity. Pure metals are not good due to their high thermal conductivity, while insulating materials are not good due to their low electrical conductivity. Thermoelectric refrigeration systems became commercial with the development of semiconductor materials, which typically have reasonably high electrical conductivity and low thermal conductivity. Thermoelectric refrigeration systems based on semiconductors consist of p-type and n-type materials. The p-type materials have positive thermoelectric power  $\alpha_p$ , while the n-type materials have negative thermoelectric power,  $\alpha_n$ . By carrying out a simple thermodynamic analysis it was shown that the temperature difference between hot and cold junctions ( $T_2 - T_1$ ), rate of refrigeration  $\dot{Q}_1$  and COP of a thermoelectric refrigeration system are given by:

$$(T_2 - T_1) = \frac{(\alpha_p - \alpha_n)T_1 I - \dot{Q}_1 - \frac{1}{2} I^2 R}{U}$$

$$\dot{Q}_1 = (\alpha_p - \alpha_n)T_1 I - U(T_2 - T_1) - \frac{1}{2} I^2 R \quad (8.14)$$

$$\text{COP} = \frac{\dot{Q}_1}{W} = \frac{(\alpha_p - \alpha_n)T_1 I - U(T_2 - T_1) - \frac{1}{2} I^2 R}{(\alpha_p - \alpha_n)(T_2 - T_1)I + I^2 R}$$

where  $\dot{Q}_1$  is the rate of refrigeration (W) obtained at temperature  $T_1$ ,  $W$  is the power input by the battery (W) and  $U$  is the effective thermal conductance between the two junctions. From the above expression it can be easily shown that in the absence of the two irreversible effects, i.e., conduction effect and Joulean effect, the COP of an ideal thermoelectric refrigeration system is same as that of a Carnot refrigerator. The temperature difference between the junctions will be maximum when the refrigeration effect is zero.

An optimum current can be obtained by maximizing each of the above performance parameters, i.e., temperature difference, refrigeration effect and COP. For example, differentiating the expression for COP with respect to  $I$  and equating it zero, we get the expressions for optimum current and maximum COP as:

$$I_{\text{opt}} = \frac{(\alpha_p - \alpha_n)(T_2 - T_1)}{R(\sqrt{1 + ZT_m} - 1)} \quad (8.15a)$$

$$\text{COP}_{\text{max}} = \frac{\left(\frac{T_1}{T_2 - T_1}\right)(\sqrt{1 + ZT_m} - \frac{T_2}{T_1})}{(\sqrt{1 + ZT_m} + 1)}$$

where  $Z$  is a property parameter called figure of merit and  $T_m$  is the mean of  $T_2$  and  $T_1$ . The figure of merit  $Z$  is given by:

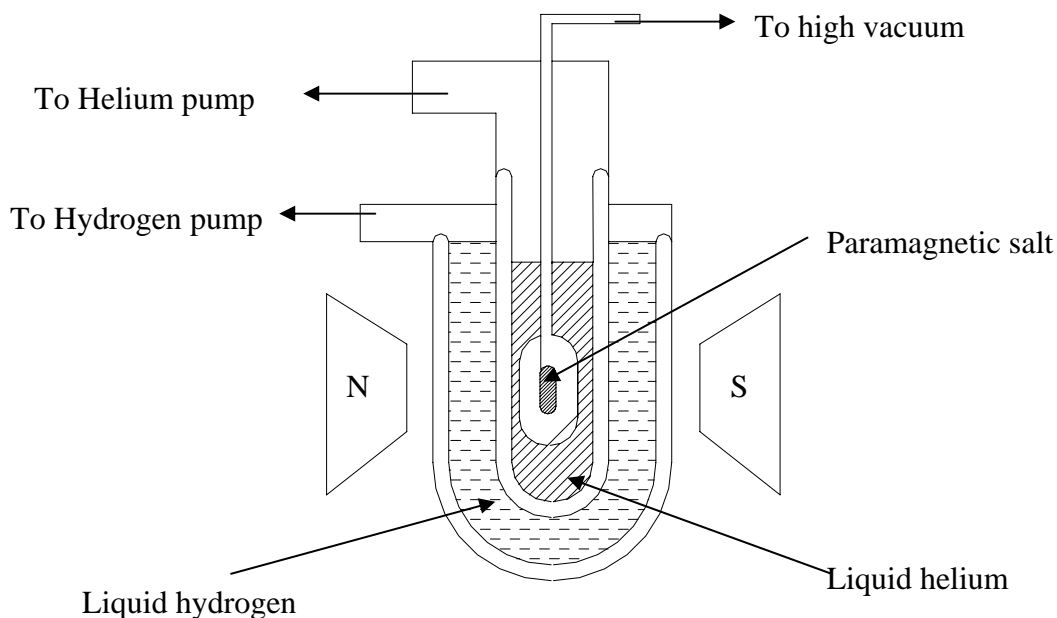
$$Z = \frac{(\alpha_p - \alpha_n)^2}{UR} \quad (8.15b)$$

It can be shown that for best performance the figure of merit  $Z$  should be as high as possible. It is shown that  $Z$  is related to the thermal and electrical conductivities of the materials and the electrical contact resistance at the junctions. For a special case where both p- and n-type materials have equal electrical and thermal conductivities ( $\sigma$  and  $k$ ) and equal but opposite values of thermoelectric power  $\alpha$ , it is shown that the maximum figure of merit  $Z_{\max}$  is given by:

$$Z_{\max} = \frac{\alpha^2 \sigma}{k(1 + \frac{2r}{\rho L})} \quad (8.16)$$

where  $\rho$  is the electrical resistivity and  $L$  is the length of the modules.

### 8.2.7. Adiabatic demagnetization



*Fig.8.7. Schematic of a setup depicting magnetic refrigeration*

Magnetic refrigeration is based on the magnetocaloric effect, discovered by E. Warburg in 1881. Similar to mechanical compression and expansion of gases, there are some materials that raise their temperatures when adiabatically magnetised, and drop their temperature when adiabatically demagnetised. Temperature very near the absolute zero may be obtained by adiabatic demagnetization of certain paramagnetic salts. Each atom of the paramagnetic salt may be considered to be a tiny magnet. If the salt is not magnetized then all its atoms or the magnets are randomly oriented such that the net magnetic force is zero. If it is exposed to a strong magnetic field, the atoms will align themselves to the direction of magnetic field. This requires work and the temperature increases during this process. If the salt is kept in a container surrounded by Helium, the heat will be absorbed by Helium. Now if the magnetic field is suddenly removed, the atoms will come back to the original random orientation. This requires work to be done by the atoms. If there is no heat transfer from surroundings, the internal energy of the salt will decrease as it does work. Consequently the salt will be cooled.

This process is used to achieve temperature near absolute zero. Paramagnetic salts like gadolinium sulphate are used. Magnetization involves alignment of electronic spin. Protons and neutron also have spins called nuclear spins, which can be aligned by magnetic field. This gives lower temperatures for a brief instant of time. This is however not macroscopic temperature but temperature associated with nuclear spin.

## Questions:

1. What is refrigeration? How does it differ from cooling? ([Answer](#))
2. Prove that the latent heat of vaporization ( $h_{fg}$ ) is equal to

$$h_{fg} = \frac{RT^2}{P} \frac{dP}{dT}$$

assuming ideal gas equation of state for vapour. (Hint: Start from the fundamental derivation of Clausius- Clapeyron equation) ([Solution](#))

3. The boiling point of a substance at 1 atm is 400K. Estimate the approximate value of the vapour pressure of the substance at 315 K. Assume:

$$\frac{\bar{h}_{fg}}{T_B} = 88 \text{ kJ/kg-mol K} \quad (\text{Solution})$$

4. The vapour pressure of solid ammonia is given by:

$$\ln P = 23.03 - \frac{3754}{T}$$

while that of liquid ammonia by:

$$\ln P = 19.49 - \frac{3063}{T}$$

where P is in mm of mercury. What are the latent heats of sublimation ( $l_{sub}$ ) vaporization ( $l_{vap}$ ) ? ([Solution](#))

5. Prove that Joule-Thompson coefficient,  $\mu_{JT}$ , is equal to

$$\mu_{JT} = \frac{\left[ T \left( \frac{\partial v}{\partial T} \right)_p - v \right]}{C_p}$$

from basic laws of thermodynamics. Here  $v$  is the specific volume and  $C_p$  is the specific heat at constant pressure.

Also show that there will be no change in temperature when ideal gas is made to undergo a throttling process. ([Solution](#))



6. Clarify whether the following statements are True or False :

1. Refrigeration is a spontaneous process. ([Answer](#))
2. Refrigeration and cooling are the same. ([Answer](#))
3. It is possible to produce cooling by addition of sodium chloride in water. ([Answer](#))
4. Higher the normal boiling point higher is the molar enthalpy of vaporization. ([Answer](#))
5. In a phase change system a substance of higher latent heat of phase change should be selected for compact systems. ([Answer](#))
6. Sudden expansion of liquids and gases is isenthalpic if a turbine is used and isentropic if its done with a throttling device. ([Answer](#))
7. The Joule Thompson coefficient ( $\mu_{JT}$ ) is the measure of deviation of real gas from ideal behaviour. ([Answer](#))
8. Isenthalpic expansion of most gases lead to cooling as maximum inversion temperature is much above room temperature. ([Answer](#))
9. Throttling at low pressure produces higher reduction in temperature compared to its throttling at high temperatures. ([Answer](#))
10. See beck effect illustrates that if an EMF is connected in between two dissimilar conductors then one of the junction becomes hot while the other becomes cold. ([Answer](#))
11. Temperatures close to absolute zero can be obtained by adiabatic demagnetization. ([Answer](#))

# Lesson

9

# Air cycle refrigeration systems

## The specific objectives of the lesson:

This lesson discusses various gas cycle refrigeration systems based on air, namely:

1. Reverse Carnot cycle & its limitations (*Section 9.4*)
2. Reverse Brayton cycle – Ideal & Actual (*Section 9.5*)
3. Aircraft refrigeration cycles, namely Simple system, Bootstrap system, Regenerative system, etc. (*Section 9.6*)

At the end of the lesson the student should be able to:

1. Describe various air cycle refrigeration systems (*Section 9.1-9.6*)
2. State the assumptions made in the analyses of air cycle systems (*Section 9.2*)
3. Show the cycles on T-s diagrams (*Section 9.4-9.6*)
4. Perform various cycle calculations (*Section 9.3-9.6*)
5. State the significance of Dry Air Rated Temperature (*Section 9.6*)

## 9.1. Introduction

Air cycle refrigeration systems belong to the general class of gas cycle refrigeration systems, in which a gas is used as the working fluid. The gas does not undergo any phase change during the cycle, consequently, all the internal heat transfer processes are sensible heat transfer processes. Gas cycle refrigeration systems find applications in air craft cabin cooling and also in the liquefaction of various gases. In the present chapter gas cycle refrigeration systems based on air are discussed.

## 9.2. Air Standard Cycle analysis

Air cycle refrigeration system analysis is considerably simplified if one makes the following assumptions:

- i. The working fluid is a fixed mass of air that behaves as an ideal gas
- ii. The cycle is assumed to be a closed loop cycle with all inlet and exhaust processes of open loop cycles being replaced by heat transfer processes to or from the environment
- iii. All the processes within the cycle are reversible, i.e., the cycle is internally reversible
- iv. The specific heat of air remains constant throughout the cycle

An analysis with the above assumptions is called as cold Air Standard Cycle (ASC) analysis. This analysis yields reasonably accurate results for most of the cycles and processes encountered in air cycle refrigeration systems. However, the analysis fails when one considers a cycle consisting of a throttling process, as the temperature drop during throttling is zero for an ideal gas, whereas the actual cycles depend exclusively on the real gas behavior to produce refrigeration during throttling.

### 9.3. Basic concepts

The temperature of an ideal gas can be reduced either by making the gas to do work in an isentropic process or by sensible heat exchange with a cooler environment. When the gas does adiabatic work in a closed system by say, expanding against a piston, its internal energy drops. Since the internal energy of the ideal gas depends only on its temperature, the temperature of the gas also drops during the process, i.e.,

$$W = m(u_1 - u_2) = mc_v(T_1 - T_2) \quad (9.1)$$

where  $m$  is the mass of the gas,  $u_1$  and  $u_2$  are the initial and final internal energies of the gas,  $T_1$  and  $T_2$  are the initial and final temperatures and  $c_v$  is the specific heat at constant volume. If the expansion is reversible and adiabatic, by using the ideal gas equation  $Pv = RT$  and the equation for isentropic process  $P_1v_1^\gamma = P_2v_2^\gamma$  the final temperature ( $T_2$ ) is related to the initial temperature ( $T_1$ ) and initial and final pressures ( $P_1$  and  $P_2$ ) by the equation:

$$T_2 = T_1 \left( \frac{P_2}{P_1} \right)^{\frac{\gamma-1}{\gamma}} \quad (9.2)$$

where  $\gamma$  is the coefficient of isentropic expansion given by:

$$\gamma = \left( \frac{c_p}{c_v} \right) \quad (9.3)$$

Isentropic expansion of the gas can also be carried out in a steady flow in a turbine which gives a net work output. Neglecting potential and kinetic energy changes, the work output of the turbine is given by:

$$W = \dot{m}(h_1 - h_2) = \dot{m}c_p(T_1 - T_2) \quad (9.4)$$

The final temperature is related to the initial temperature and initial and final pressures by Eq. (9.2).

### 9.4. Reversed Carnot cycle employing a gas

Reversed Carnot cycle is an ideal refrigeration cycle for constant temperature external heat source and heat sinks. Figure 9.1(a) shows the schematic of a reversed Carnot refrigeration system using a gas as the working fluid along with the cycle diagram on T-s and P-v coordinates. As shown, the cycle consists of the following four processes:

Process 1-2: Reversible, adiabatic compression in a compressor

Process 2-3: Reversible, isothermal heat rejection in a compressor

Process 3-4: Reversible, adiabatic expansion in a turbine

Process 4-1: Reversible, isothermal heat absorption in a turbine

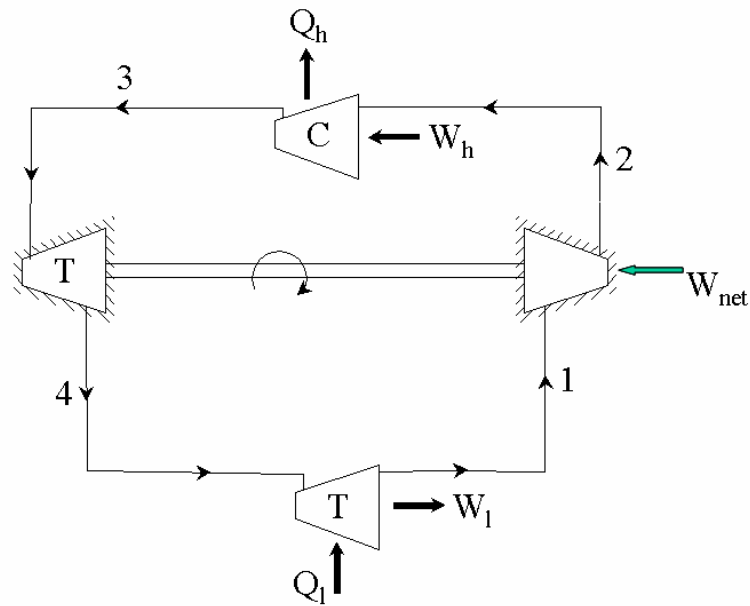


Fig. 9.1(a). Schematic of a reverse Carnot refrigeration system

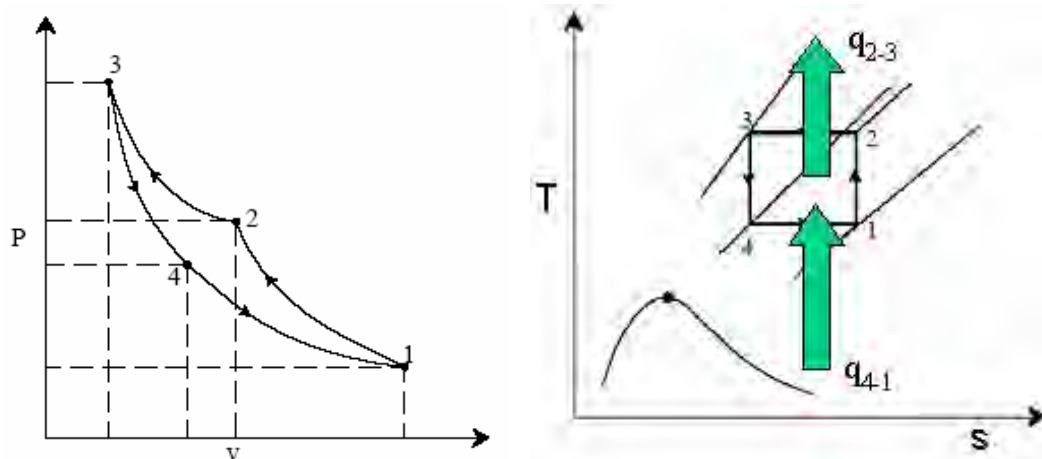


Fig. 9.1(b). Reverse Carnot refrigeration system in P-v and T-s coordinates

The heat transferred during isothermal processes 2-3 and 4-1 are given by:

$$q_{2-3} = \int_2^3 T \cdot ds = T_h (s_3 - s_2) \quad (9.5a)$$

$$q_{4-1} = \int_4^1 T \cdot ds = T_l (s_1 - s_4) \quad (9.5b)$$

$$s_1 = s_2 \quad \text{and} \quad s_3 = s_4, \quad \text{hence} \quad s_2 - s_3 = s_1 - s_4 \quad (9.6)$$

Applying first law of thermodynamics to the closed cycle,

$$\oint \delta q = (q_{4-1} + q_{2-3}) = \oint \delta w = (w_{2-3} - w_{4-1}) = -w_{\text{net}} \quad (9.7)$$

the work of isentropic expansion,  $w_{3-4}$  exactly matches the work of isentropic compression  $w_{1-2}$ .

the COP of the Carnot system is given by:

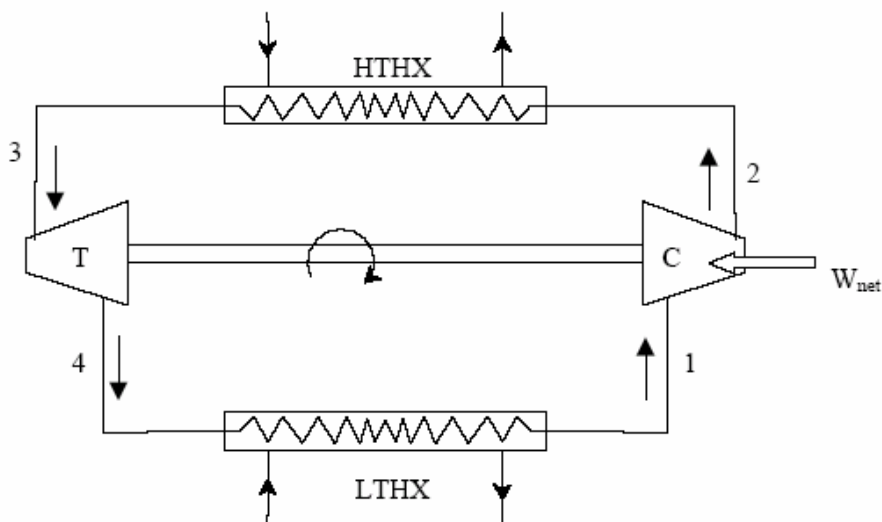
$$\text{COP}_{\text{Carnot}} = \frac{|q_{4-1}|}{|w_{\text{net}}|} = \left( \frac{T_1}{T_h - T_1} \right) \quad (9.8)$$

Thus the COP of the Carnot system depends only on the refrigeration ( $T_1$ ) and heat rejection ( $T_h$ ) temperatures only.

### Limitations of Carnot cycle:

Carnot cycle is an idealization and it suffers from several practical limitations. One of the main difficulties with Carnot cycle employing a gas is the difficulty of achieving isothermal heat transfer during processes 2-3 and 4-1. For a gas to have heat transfer isothermally, it is essential to carry out work transfer from or to the system when heat is transferred to the system (process 4-1) or from the system (process 2-3). This is difficult to achieve in practice. In addition, the volumetric refrigeration capacity of the Carnot system is very small leading to large compressor displacement, which gives rise to large frictional effects. All actual processes are irreversible, hence completely reversible cycles are idealizations only.

## 9.5. Ideal reverse Brayton cycle



*Fig. 9.2(a). Schematic of a closed reverse Brayton cycle*

This is an important cycle frequently employed in gas cycle refrigeration systems. This may be thought of as a modification of reversed Carnot cycle, as the two isothermal processes of Carnot cycle are replaced by two isobaric heat transfer processes. This cycle is also called as Joule or Bell-Coleman cycle. Figure 9.2(a) and (b) shows the schematic of a closed, reverse Brayton cycle and also the cycle on T-s

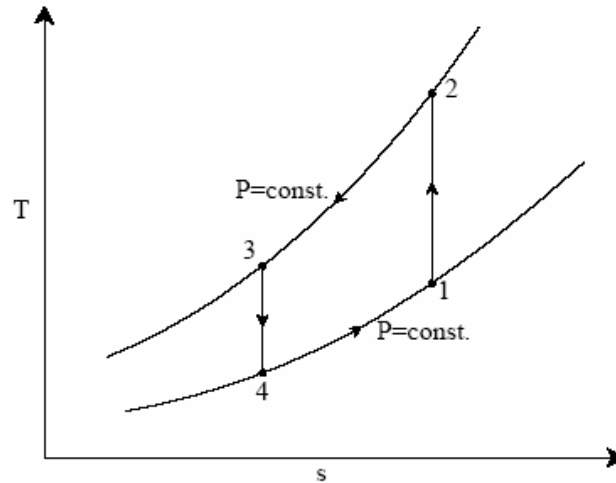
diagram. As shown in the figure, the ideal cycle consists of the following four processes:

Process 1-2: Reversible, adiabatic compression in a compressor

Process 2-3: Reversible, isobaric heat rejection in a heat exchanger

Process 3-4: Reversible, adiabatic expansion in a turbine

Process 4-1: Reversible, isobaric heat absorption in a heat exchanger



**Fig. 9.2(b).** Reverse Brayton cycle in  $T$ - $s$  plane

Process 1-2: Gas at low pressure is compressed isentropically from state 1 to state 2. Applying steady flow energy equation and neglecting changes in kinetic and potential energy, we can write:

$$W_{1-2} = \dot{m}(h_2 - h_1) = \dot{m} c_p (T_2 - T_1)$$

$$s_2 = s_1 \quad (9.9)$$

$$\text{and } T_2 = T_1 \left( \frac{P_2}{P_1} \right)^{\frac{\gamma-1}{\gamma}} = T_1 r_p^{\frac{\gamma-1}{\gamma}}$$

where  $r_p = (P_2/P_1)$  = pressure ratio

Process 2-3: Hot and high pressure gas flows through a heat exchanger and rejects heat sensibly and isobarically to a heat sink. The enthalpy and temperature of the gas drop during the process due to heat exchange, no work transfer takes place and the entropy of the gas decreases. Again applying steady flow energy equation and second  $T ds$  equation:

$$Q_{2-3} = \dot{m}(h_2 - h_3) = \dot{m} c_p (T_2 - T_3)$$

$$s_2 - s_3 = c_p \ln \frac{T_2}{T_3} \quad (9.10)$$

$$P_2 = P_3$$

Process 3-4: High pressure gas from the heat exchanger flows through a turbine, undergoes isentropic expansion and delivers net work output. The temperature of the gas drops during the process from  $T_3$  to  $T_4$ . From steady flow energy equation:

$$\begin{aligned} W_{3-4} &= \dot{m}(h_3 - h_4) = \dot{m} c_p (T_3 - T_4) \\ s_3 &= s_4 \\ \text{and } T_3 &= T_4 \left( \frac{P_3}{P_4} \right)^{\frac{\gamma-1}{\gamma}} = T_4 r_p^{\frac{\gamma-1}{\gamma}} \end{aligned} \quad (9.11)$$

where  $r_p = (P_3/P_4) =$  pressure ratio

Process 4-1: Cold and low pressure gas from turbine flows through the low temperature heat exchanger and extracts heat sensibly and isobarically from a heat source, providing a useful refrigeration effect. The enthalpy and temperature of the gas rise during the process due to heat exchange, no work transfer takes place and the entropy of the gas increases. Again applying steady flow energy equation and second T ds equation:

$$\begin{aligned} Q_{4-1} &= \dot{m}(h_1 - h_4) = \dot{m} c_p (T_1 - T_4) \\ s_4 - s_1 &= c_p \ln \frac{T_4}{T_1} \\ P_4 &= P_1 \end{aligned} \quad (9.12)$$

From the above equations, it can be easily shown that:

$$\left( \frac{T_2}{T_1} \right) = \left( \frac{T_3}{T_4} \right) \quad (9.13)$$

Applying 1<sup>st</sup> law of thermodynamics to the entire cycle:

$$\oint \delta q = (q_{4-1} - q_{2-3}) = \oint \delta w = (w_{3-4} - w_{1-2}) = -w_{\text{net}} \quad (9.14)$$

The COP of the reverse Brayton cycle is given by:

$$\text{COP} = \left| \frac{q_{4-1}}{w_{\text{net}}} \right| = \left( \frac{(T_1 - T_4)}{(T_2 - T_1) - (T_3 - T_4)} \right) \quad (9.15)$$

using the relation between temperatures and pressures, the COP can also be written as:

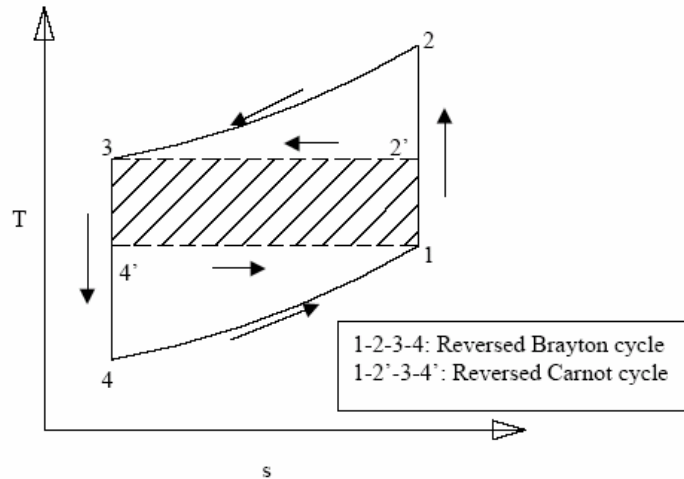
$$\text{COP} = \left( \frac{(T_1 - T_4)}{(T_2 - T_1) - (T_3 - T_4)} \right) = \left( \frac{T_4}{T_3 - T_4} \right) = \left( \frac{(T_1 - T_4)}{(T_1 - T_4)(r_p^{\frac{\gamma-1}{\gamma}} - 1)} \right) = (r_p^{\frac{\gamma-1}{\gamma}} - 1)^{-1} \quad (9.16)$$

From the above expression for COP, the following observations can be made:



- a) For fixed heat rejection temperature ( $T_3$ ) and fixed refrigeration temperature ( $T_1$ ), the COP of reverse Brayton cycle is always lower than the COP of reverse Carnot cycle (Fig. 9.3), that is

$$\text{COP}_{\text{Brayton}} = \left( \frac{T_4}{T_3 - T_4} \right) < \text{COP}_{\text{Carnot}} = \left( \frac{T_1}{T_3 - T_1} \right)$$



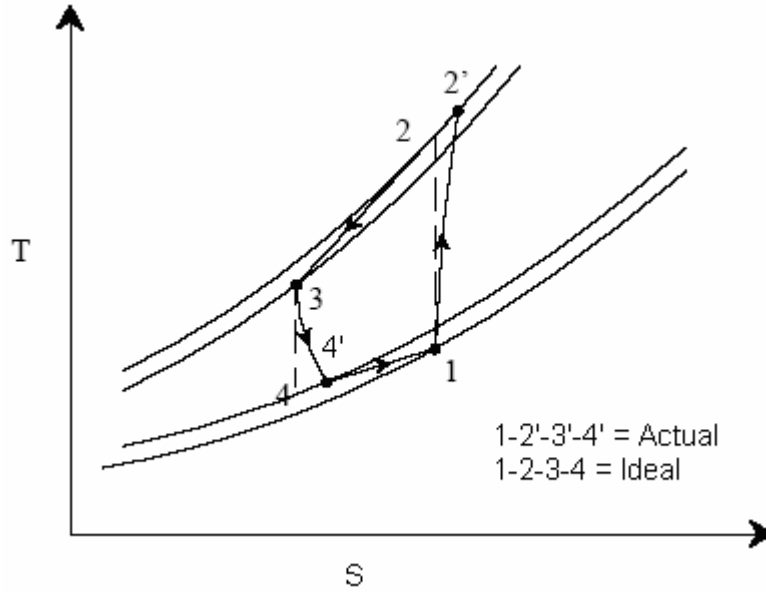
**Fig. 9.3.** Comparison of reverse Carnot and reverse Brayton cycle in  $T$ - $s$  plane

- b) COP of Brayton cycle approaches COP of Carnot cycle as  $T_1$  approaches  $T_4$  (thin cycle), however, the specific refrigeration effect [ $c_p(T_1 - T_4)$ ] also reduces simultaneously.
- c) COP of reverse Brayton cycle decreases as the pressure ratio  $r_p$  increases

#### Actual reverse Brayton cycle:

The actual reverse Brayton cycle differs from the ideal cycle due to:

- i. Non-isentropic compression and expansion processes
- ii. Pressure drops in cold and hot heat exchangers



**Fig. 9.4.** Comparison of ideal and actual Brayton cycles T-s plane

Figure 9.4 shows the ideal and actual cycles on T-s diagram. Due to these irreversibilities, the compressor work input increases and turbine work output reduces. The actual work transfer rates of compressor and turbine are then given by:

$$W_{1-2,act} = \frac{W_{1-2,isen}}{\eta_{c,isen}} \quad (9.17)$$

$$W_{3-4,act} = \eta_{t,isen} W_{3-4,isen} \quad (9.18)$$

where  $\eta_{c,isen}$  and  $\eta_{t,isen}$  are the isentropic efficiencies of compressor and turbine, respectively. In the absence of pressure drops, these are defined as:

$$\eta_{c,isen} = \frac{(h_2 - h_1)}{(h_{2'} - h_1)} = \frac{(T_2 - T_1)}{(T_{2'} - T_1)} \quad (9.20)$$

$$\eta_{t,isen} = \frac{(h_3 - h_4)}{(h_3 - h_{4'})} = \frac{(T_3 - T_4)}{(T_3 - T_4')} \quad (9.21)$$

The actual net work input,  $w_{net,act}$  is given by:

$$W_{net,act} = W_{1-2,act} - W_{3-4,act} \quad (9.22)$$

thus the net work input increases due to increase in compressor work input and reduction in turbine work output. The refrigeration effect also reduces due to the irreversibilities. As a result, the COP of actual reverse Brayton cycles will be considerably lower than the ideal cycles. Design of efficient compressors and turbines plays a major role in improving the COP of the system.

In practice, reverse Brayton cycles can be open or closed. In open systems, cold air at the exit of the turbine flows into a room or cabin (cold space), and air to the

compressor is taken from the cold space. In such a case, the low side pressure will be atmospheric. In closed systems, the same gas (air) flows through the cycle in a closed manner. In such cases it is possible to have low side pressures greater than atmospheric. These systems are known as *dense air systems*. Dense air systems are advantageous as it is possible to reduce the volume of air handled by the compressor and turbine at high pressures. Efficiency will also be high due to smaller pressure ratios. It is also possible to use gases other than air (e.g. helium) in closed systems.

## 9.6. Aircraft cooling systems

In an aircraft, cooling systems are required to keep the cabin temperatures at a comfortable level. Even though the outside temperatures are very low at high altitudes, still cooling of cabin is required due to:

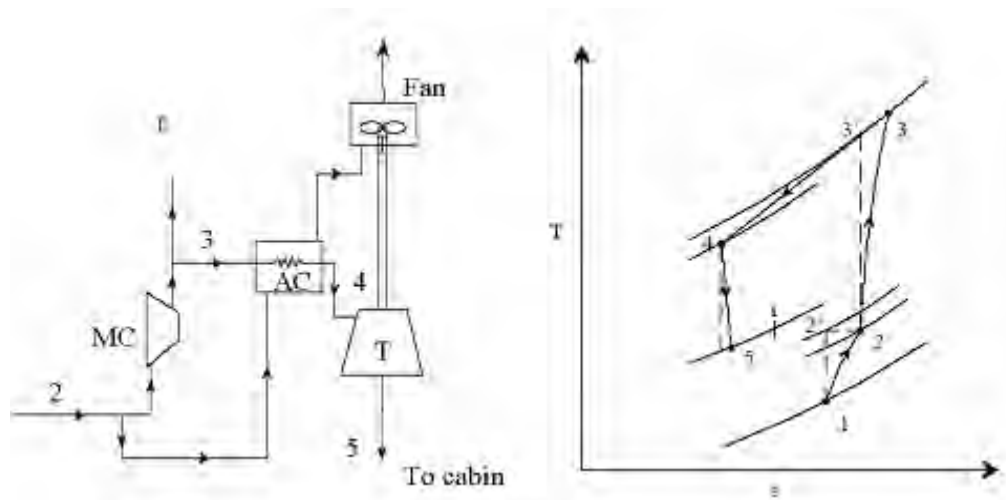
- i. Large internal heat generation due to occupants, equipment etc.
- ii. Heat generation due to skin friction caused by the fast moving aircraft
- iii. At high altitudes, the outside pressure will be sub-atmospheric. When air at this low pressure is compressed and supplied to the cabin at pressures close to atmospheric, the temperature increases significantly. For example, when outside air at a pressure of 0.2 bar and temperature of 223 K (at 10000 m altitude) is compressed to 1 bar, its temperature increases to about 353 K. If the cabin is maintained at 0.8 bar, the temperature will be about 332 K. This effect is called as ram effect. This effect adds heat to the cabin, which needs to be taken out by the cooling system.
- iv. Solar radiation

For low speed aircraft flying at low altitudes, cooling system may not be required, however, for high speed aircraft flying at high altitudes, a cooling system is a must.

Even though the COP of air cycle refrigeration is very low compared to vapour compression refrigeration systems, it is still found to be most suitable for aircraft refrigeration systems as:

- i. Air is cheap, safe, non-toxic and non-flammable. Leakage of air is not a problem
- ii. Cold air can directly be used for cooling thus eliminating the low temperature heat exchanger (open systems) leading to lower weight
- iii. The aircraft engine already consists of a high speed turbo-compressor, hence separate compressor for cooling system is not required. This reduces the weight per kW cooling considerably. Typically, less than 50% of an equivalent vapour compression system
- iv. Design of the complete system is much simpler due to low pressures. Maintenance required is also less.

### 9.6.1. Simple aircraft refrigeration cycle:



**Fig. 9.5.** Schematic of a simple aircraft refrigeration cycle

Figure 9.5 shows the schematic of a simple aircraft refrigeration system and the operating cycle on T-s diagram. This is an open system. As shown in the T-s diagram, the outside low pressure and low temperature air (state 1) is compressed due to ram effect to ram pressure (state 2). During this process its temperature increases from 1 to 2. This air is compressed in the main compressor to state 3, and is cooled to state 4 in the air cooler. Its pressure is reduced to cabin pressure in the turbine (state 5), as a result its temperature drops from 4 to 5. The cold air at state 5 is supplied to the cabin. It picks up heat as it flows through the cabin providing useful cooling effect. The power output of the turbine is used to drive the fan, which maintains the required air flow over the air cooler. This simple system is good for ground cooling (when the aircraft is not moving) as fan can continue to maintain airflow over the air cooler.

By applying steady flow energy equation to the ramming process, the temperature rise at the end of the ram effect can be shown to be:

$$\frac{T_2}{T_1} = 1 + \frac{\gamma - 1}{2} M^2 \quad (9.23)$$

where M is the Mach number, which is the ratio of velocity of the aircraft (C) to the sonic velocity a ( $a = \sqrt{\gamma RT_1}$ ), i.e.,

$$M = \frac{C}{a} = \frac{C}{\sqrt{\gamma RT_1}} \quad (9.24)$$

Due to irreversibilities, the actual pressure at the end of ramming will be less than the pressure resulting from isentropic compression. The ratio of actual pressure rise to the isentropic pressure rise is called as ram efficiency,  $\eta_{\text{Ram}}$ , i.e.,

$$\eta_{\text{Ram}} = \frac{(P_2 - P_1)}{(P_{2'} - P_1)} \quad (9.25)$$

The refrigeration capacity of the simple aircraft cycle discussed,  $\dot{Q}$  is given by:

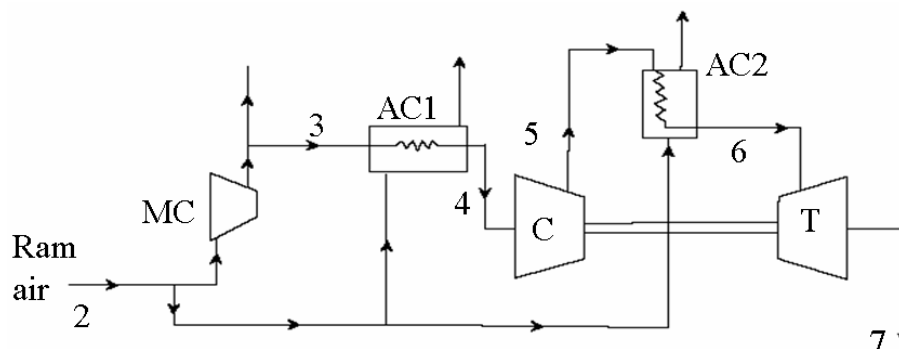
$$\dot{Q} = \dot{m} c_p (T_i - T_5) \quad (9.26)$$

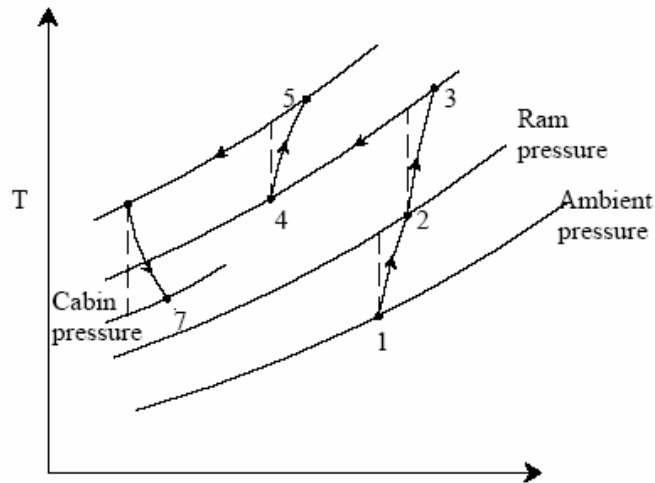
where  $\dot{m}$  is the mass flow rate of air through the turbine.

### 9.6.2. Bootstrap system:

Figure 9.6 shows the schematic of a bootstrap system, which is a modification of the simple system. As shown in the figure, this system consists of two heat exchangers (air cooler and aftercooler), instead of one air cooler of the simple system. It also incorporates a secondary compressor, which is driven by the turbine of the cooling system. This system is suitable for high speed aircraft, where in the velocity of the aircraft provides the necessary airflow for the heat exchangers, as a result a separate fan is not required. As shown in the cycle diagram, ambient air state 1 is pressurized to state 2 due to the ram effect. This air is further compressed to state 3 in the main compressor. The air is then cooled to state 4 in the air cooler. The heat rejected in the air cooler is absorbed by the ram air at state 2. The air from the air cooler is further compressed from state 4 to state 5 in the secondary compressor. It is then cooled to state 6 in the after cooler, expanded to cabin pressure in the cooling turbine and is supplied to the cabin at a low temperature  $T_7$ . Since the system does not consist of a separate fan for driving the air through the heat exchangers, it is not suitable for ground cooling. However, in general ground cooling is normally done by an external air conditioning system as it is not efficient to run the aircraft engine just to provide cooling when it is grounded.

Other modifications over the simple system are: regenerative system and reduced ambient system. In a regenerative system, a part of the cold air from the cooling turbine is used for precooling the air entering the turbine. As a result much lower temperatures are obtained at the exit of the cooling turbine, however, this is at the expense of additional weight and design complexity. The cooling turbine drives a fan similar to the simple system. The regenerative system is good for both ground cooling as well as high speed aircrafts. The reduced ambient system is well-suited for supersonic aircrafts and rockets.





*Fig. 9.6. Schematic of a bootstrap system*

### **Dry Air Rated Temperature (DART):**

The concept of Dry Air Rated Temperature is used to compare different aircraft refrigeration cycles. Dry Air Rated Temperature is defined as the temperature of the air at the exit of the cooling turbine in the absence of moisture condensation. For condensation not to occur during expansion in turbine, the dew point temperature and hence moisture content of the air should be very low, i.e., the air should be very dry. The aircraft refrigeration systems are rated based on the mass flow rate of air at the design DART. The cooling capacity is then given by:

$$\dot{Q} = \dot{m} c_p (T_i - T_{\text{DART}}) \quad (9.27)$$

where  $\dot{m}$  is the mass flow rate of air,  $T_{\text{DART}}$  and  $T_i$  are the dry air rated temperature and cabin temperature, respectively.

A comparison between different aircraft refrigeration systems based on DART at different Mach numbers shows that:

- i. DART increases monotonically with Mach number for all the systems except the reduced ambient system
- ii. The simple system is adequate at low Mach numbers
- iii. At high Mach numbers either bootstrap system or regenerative system should be used
- iv. Reduced ambient temperature system is best suited for very high Mach number, supersonic aircrafts

## Questions:

1. A refrigerator working on Bell-Coleman cycle (Reverse brayton cycle) operates between 1 bar and 10 bar. Air is drawn from cold chamber at  $-10^{\circ}\text{C}$ . Air coming out of compressor is cooled to  $50^{\circ}\text{C}$  before entering the expansion cylinder. Polytropic law  $P.V^{1.3} = \text{constant}$  is followed during expansion and compression. Find theoretical C.O.P of the origin. Take  $\gamma = 1.4$  and  $C_p = 1.00 \text{ kJ/kg } ^{\circ}\text{C}$  for air. ([Solution](#))

2. An air refrigerator working on the principle of Bell-Coleman cycle. The air into the compressor is at 1 atm at  $-10^{\circ}\text{C}$ . It is compressed to 10 atm and cooled to  $40^{\circ}\text{C}$  at the same pressure. It is then expanded to 1 atm and discharged to take cooling load. The air circulation is 1 kg/s.

The isentropic efficiency of the compressor = 80%

The isentropic efficiency of the expander = 90%

Find the following:

- i) Refrigeration capacity of the system
- ii) C.O.P of the system

Take  $\gamma = 1.4$ ,  $C_p = 1.00 \text{ kJ/kg } ^{\circ}\text{C}$  ([Solution](#))

3. A Carnot refrigerator extracts 150 kJ of heat per minute from a space which is maintained at  $-20^{\circ}\text{C}$  and is discharged to atmosphere at  $45^{\circ}\text{C}$ . Find the work required to run the unit. ([Solution](#))

4. A cold storage plant is required to store 50 tons of fish.

The temperature at which fish was supplied =  $35^{\circ}\text{C}$

Storage temperature of fish =  $-10^{\circ}\text{C}$

$C_p$  of fish above freezing point =  $2.94 \text{ kJ/kg } ^{\circ}\text{C}$

$C_p$  of fish below freezing point =  $1.26 \text{ kJ/kg } ^{\circ}\text{C}$

Freezing point of fish =  $-5^{\circ}\text{C}$

Latent heat of fish =  $250 \text{ kJ/kg}$

If the cooling is achieved within half of a day, find:

- a) Capacity of the refrigerating plant
- b) Carnot COP
- c) If actual  $\text{COP} = \frac{\text{Carnot COP}}{2.5}$  find the power required to run the plant.

([Solution](#))

5. A boot strap cooling system of 10 tons is used in an aeroplane. The temperature and pressure conditions of atmosphere are  $20^{\circ}\text{C}$  and 0.9 atm. The pressure of air is increased from 0.9 atm to 1.1 atm due to ramming. The pressures of air leaving the main and auxiliary compressor are 3 atm and 4 atm respectively. Isentropic efficiency of compressors and turbine are 0.85 and 0.8 respectively. 50% of the total heat of air leaving the main compressor is removed in the first heat exchanger and 30% of their

total heat of air leaving the auxiliary compressor is removed in the second heat exchanger using removed air. Find:

- a) Power required to take cabin load
- b) COP of the system

The cabin pressure is 1.02 atm and temperature of air leaving the cabin should be greater than 25°C. Assume ramming action to be isentropic. ([Solution](#))

6. A simple air cooled system is used for an aeroplane to take a load of 10 tons. Atmospheric temperature and pressure is 25°C and 0.9 atm respectively. Due to ramming the pressure of air is increased from 0.9 atm, to 1 atm. The pressure of air leaving the main compressor is 3.5 atm and its 50% heat is removed in the air-cooled heat exchanger and then it is passed through a evaporator for future cooling. The temperature of air is reduced by 10°C in the evaporator. Lastly the air is passed through cooling turbine and is supplied to the cooling cabin where the pressure is 1.03 atm. Assuming isentropic efficiency of the compressor and turbine are 75% and 70%, find

- a) Power required to take the load in the cooling cabin
- b) COP of the system.

The temperature of air leaving the cabin should not exceed 25°C. ([Solution](#))

7. True and False

1. COP of a Carnot system depends only on the refrigeration and heat rejection temperatures only. ([Answer](#))
2. As heat transfer from a gas can be done isothermally, Carnot cycle is easy to implement practically. ([Answer](#))
3. For a fixed heat rejection and refrigeration temperature, the COP of a brayton cycle is lower than COP of reverse Carnot cycle. ([Answer](#))
4. Efficiency of dense air systems are low as operating pressures are higher ([Answer](#))
5. DART is the temperature of the air at the exit of the cooling turbine. ([Answer](#))
6. A Simple system is adequate to handle high Mach numbers. ([Answer](#))



# Lesson

## 10

# Vapour Compression Refrigeration Systems

## The specific objectives of the lesson:

This lesson discusses the most commonly used refrigeration system, i.e. Vapour compression refrigeration system. The following things are emphasized in detail:

1. The Carnot refrigeration cycle & its practical limitations (*Section 10.3*)
2. The Standard Vapour compression Refrigeration System (*Section 10.4*)
3. Analysis of Standard Vapour compression Refrigeration System (*Section 10.5*)

At the end of the lesson the student should be able to:

1. Analyze and perform cyclic calculations for Carnot refrigeration cycle (*Section 10.3*)
2. State the difficulties with Carnot refrigeration cycle (*Section 10.3*)
3. Analyze and perform cyclic calculations for standard vapour compression refrigeration systems (*Section 10.4*)
4. Perform various cycle calculations for different types of refrigerants (*Section 10.4*)

## 10.1. Comparison between gas cycles and vapor cycles

Thermodynamic cycles can be categorized into gas cycles and vapour cycles. As mentioned in the previous chapter, in a typical gas cycle, the working fluid (a gas) does not undergo phase change, consequently the operating cycle will be away from the vapour dome. In gas cycles, heat rejection and refrigeration take place as the gas undergoes sensible cooling and heating. In a vapour cycle the working fluid undergoes phase change and refrigeration effect is due to the vaporization of refrigerant liquid. If the refrigerant is a pure substance then its temperature remains constant during the phase change processes. However, if a zeotropic mixture is used as a refrigerant, then there will be a temperature glide during vaporization and condensation. Since the refrigeration effect is produced during phase change, large amount of heat (latent heat) can be transferred per kilogram of refrigerant at a near constant temperature. Hence, the required mass flow rates for a given refrigeration capacity will be much smaller compared to a gas cycle. Vapour cycles can be subdivided into vapour compression systems, vapour absorption systems, vapour jet systems etc. Among these the vapour compression refrigeration systems are predominant.

## 10.2. Vapour Compression Refrigeration Systems

As mentioned, vapour compression refrigeration systems are the most commonly used among all refrigeration systems. As the name implies, these systems belong to the general class of vapour cycles, wherein the working fluid (refrigerant) undergoes phase change at least during one process. In a vapour compression refrigeration system, refrigeration is obtained as the refrigerant evaporates at low temperatures. The input to the system is in the form of mechanical energy required to run the compressor. Hence these systems are also called as mechanical refrigeration systems. Vapour compression refrigeration

systems are available to suit almost all applications with the refrigeration capacities ranging from few Watts to few megawatts. A wide variety of refrigerants can be used in these systems to suit different applications, capacities etc. The actual vapour compression cycle is based on Evans-Perkins cycle, which is also called as reverse Rankine cycle. Before the actual cycle is discussed and analysed, it is essential to find the upper limit of performance of vapour compression cycles. This limit is set by a completely reversible cycle.

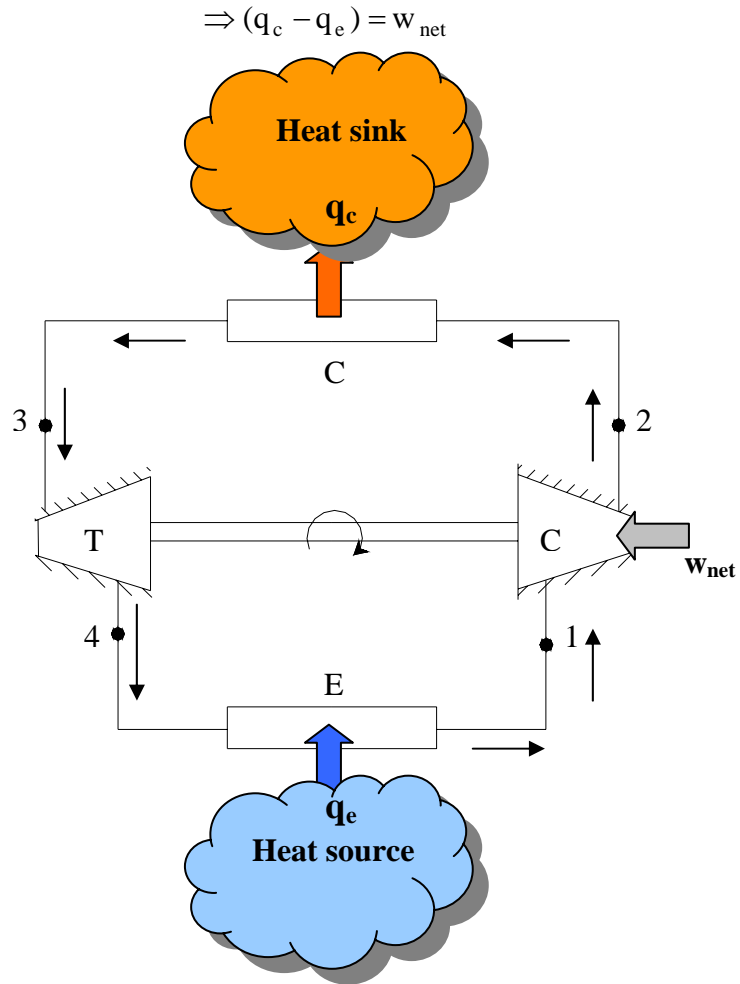
### 10.3. The Carnot refrigeration cycle

Carnot refrigeration cycle is a completely reversible cycle, hence is used as a model of perfection for a refrigeration cycle operating between a constant temperature heat source and sink. It is used as reference against which the real cycles are compared. Figures 10.1 (a) and (b) show the schematic of a Carnot vapour compression refrigeration system and the operating cycle on T-s diagram.

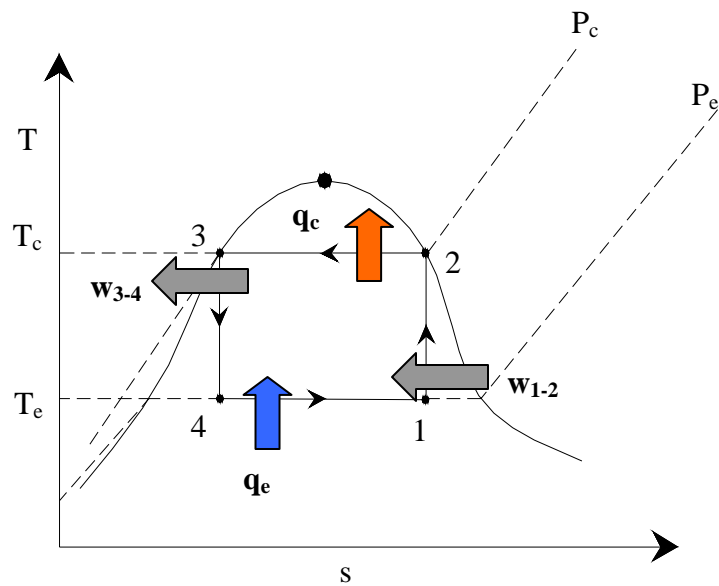
As shown in Fig.10.1(a), the basic Carnot refrigeration system for pure vapour consists of four components: compressor, condenser, turbine and evaporator. Refrigeration effect ( $q_{4-1} = q_e$ ) is obtained at the evaporator as the refrigerant undergoes the process of vaporization (process 4-1) and extracts the latent heat from the low temperature heat source. The low temperature, low pressure vapour is then compressed isentropically in the compressor to the heat sink temperature  $T_c$ . The refrigerant pressure increases from  $P_e$  to  $P_c$  during the compression process (process 1-2) and the exit vapour is saturated. Next the high pressure, high temperature saturated refrigerant undergoes the process of condensation in the condenser (process 2-3) as it rejects the heat of condensation ( $q_{2-3} = q_c$ ) to an external heat sink at  $T_c$ . The high pressure saturated liquid then flows through the turbine and undergoes isentropic expansion (process 3-4). During this process, the pressure and temperature fall from  $P_c, T_c$  to  $P_e, T_e$ . Since a saturated liquid is expanded in the turbine, some amount of liquid flashes into vapour and the exit condition lies in the two-phase region. This low temperature and low pressure liquid-vapour mixture then enters the evaporator completing the cycle. Thus as shown in Fig.10.1(b), the cycle involves two isothermal heat transfer processes (processes 4-1 and 2-3) and two isentropic work transfer processes (processes 1-2 and 3-4). Heat is extracted isothermally at evaporator temperature  $T_e$  during process 4-1, heat is rejected isothermally at condenser temperature  $T_c$  during process 2-3. Work is supplied to the compressor during the isentropic compression (1-2) of *refrigerant vapour* from evaporator pressure  $P_e$  to condenser pressure  $P_c$ , and work is produced by the system as *refrigerant liquid* expands isentropically in the turbine from condenser pressure  $P_c$  to evaporator pressure  $P_e$ . All the processes are both internally as well as externally reversible, i.e., net entropy generation for the system and environment is zero.

Applying first and second laws of thermodynamics to the Carnot refrigeration cycle,

$$\begin{aligned} \oint \delta q &= \oint \delta w \\ \oint \delta q &= q_{4-1} - q_{2-3} = q_e - q_c \\ \oint \delta w &= w_{3-4} - w_{1-2} = w_T - w_C = -w_{\text{net}} \end{aligned} \quad (10.1)$$



**Fig.10.1(a):** Schematic of a Carnot refrigeration system



**Fig. 10.1(b):** Carnot refrigeration cycle on *T-s* diagram

now for the reversible, isothermal heat transfer processes 2-3 and 4-1, we can write:

$$q_c = -q_{2-3} = -\int_2^3 T.ds = T_c(s_2 - s_3) \quad (10.2)$$

$$q_e = q_{4-1} = \int_4^1 T.ds = T_e(s_1 - s_4) \quad (10.3)$$

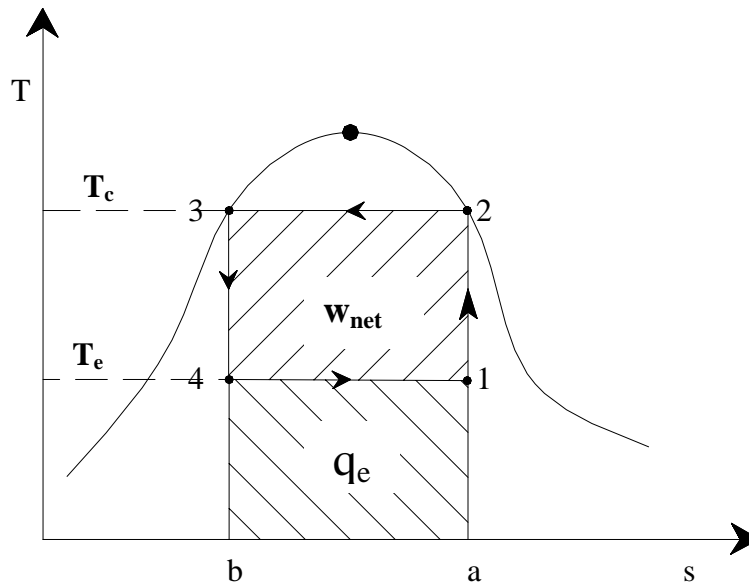
where  $T_e$  and  $T_c$  are the evaporator and condenser temperatures, respectively, and,

$$s_1 = s_2 \text{ and } s_3 = s_4 \quad (10.4)$$

the Coefficient of Performance (COP) is given by:

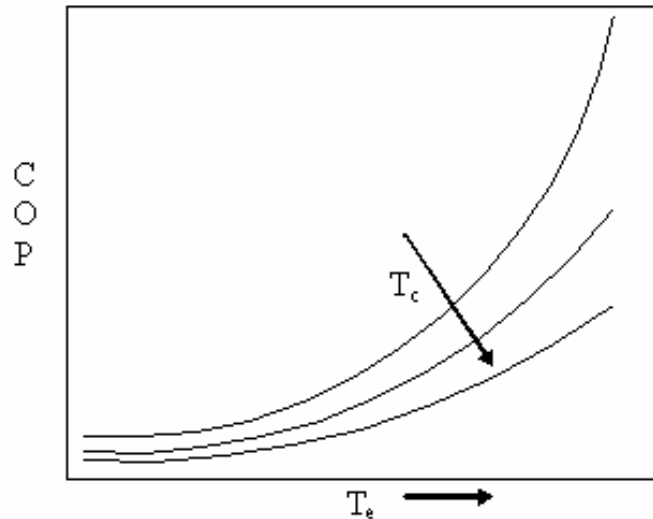
$$\text{COP}_{\text{Carnot}} = \frac{\text{refrigeration effect}}{\text{net work input}} = \frac{q_e}{w_{\text{net}}} = \frac{T_e(s_1 - s_4)}{T_c(s_2 - s_3) - T_e(s_1 - s_4)} = \left( \frac{T_e}{T_c - T_e} \right) \quad (10.5)$$

thus the COP of Carnot refrigeration cycle is a function of evaporator and condenser temperatures only and is independent of the nature of the working substance. This is the reason why exactly the same expression was obtained for air cycle refrigeration systems operating on Carnot cycle (Lesson 9). The Carnot COP sets an upper limit for refrigeration systems operating between two constant temperature thermal reservoirs (heat source and sink). From Carnot's theorems, for the same heat source and sink temperatures, no irreversible cycle can have COP higher than that of Carnot COP.



**Fig.10.2.** Carnot refrigeration cycle represented in  $T$ - $s$  plane

It can be seen from the above expression that the COP of a Carnot refrigeration system increases as the evaporator temperature increases and condenser temperature decreases. This can be explained very easily with the help of the T-s diagram (Fig.10.2). As shown in the figure, COP is the ratio of area a-1-4-b to the area 1-2-3-4. For a fixed condenser temperature  $T_c$ , as the evaporator temperature  $T_e$  increases, area a-1-4-b ( $q_e$ ) increases and area 1-2-3-4 ( $w_{net}$ ) decreases as a result, COP increases rapidly. Similarly for a fixed evaporator temperature  $T_e$ , as the condensing temperature  $T_c$  increases, the net work input (area 1-2-3-4) increases, even though cooling output remains constant, as a result the COP falls. Figure 10.3 shows the variation of Carnot COP with evaporator temperature for different condenser temperatures. It can be seen that the COP increases sharply with evaporator temperatures, particularly at high condensing temperatures. COP reduces as the condenser temperature increases, but the effect becomes marginal at low evaporator temperatures. It will be shown later that actual vapour compression refrigeration systems also behave in a manner similar to that of Carnot refrigeration systems as far as the performance trends are concerned.



**Fig.10.3.** Effects of evaporator and condenser temperatures on Carnot COP

**Practical difficulties with Carnot refrigeration system:**

It is difficult to build and operate a Carnot refrigeration system due to the following practical difficulties:

- i. During process 1-2, a mixture consisting of liquid and vapour have to be compressed isentropically in the compressor. Such a compression is known as *wet compression* due to the presence of liquid. In practice, wet compression is very difficult especially with reciprocating compressors. This problem is particularly severe in case of high speed reciprocating compressors, which get damaged due to the presence of liquid droplets in the vapour. Even though some types of compressors can tolerate the presence of liquid in

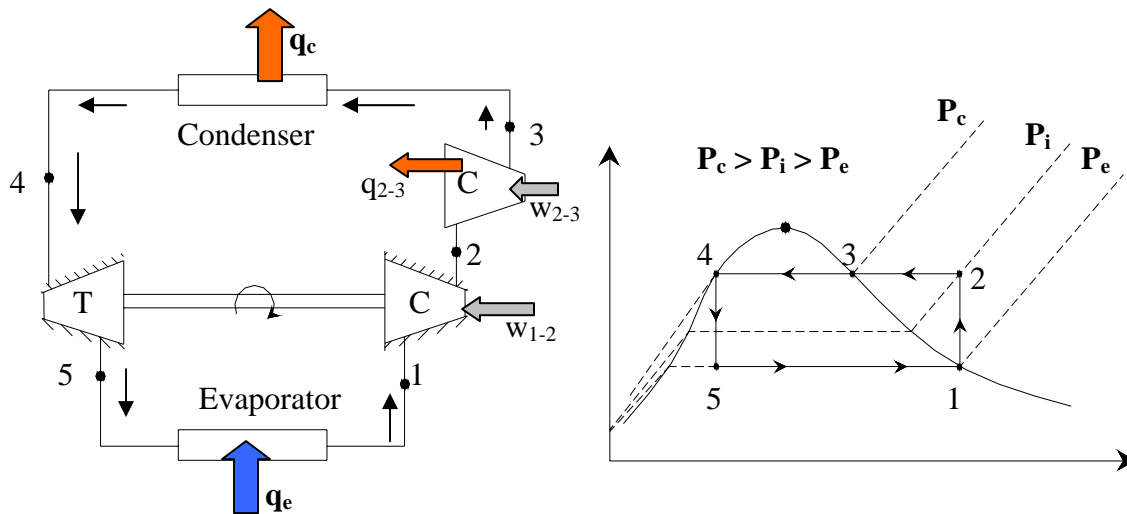
vapour, since reciprocating compressors are most widely used in refrigeration, traditionally *dry compression* (compression of vapour only) is preferred to wet compression.

ii. The second practical difficulty with Carnot cycle is that using a turbine and extracting work from the system during the isentropic expansion of liquid refrigerant is not economically feasible, particularly in case of small capacity systems. This is due to the fact that the specific work output (per kilogram of refrigerant) from the turbine is given by:

$$w_{3-4} = \int_{P_e}^{P_c} v \cdot dP \quad (10.6)$$

since the specific volume of liquid is much smaller compared to the specific volume of a vapour/gas, the work output from the turbine in case of the liquid will be small. In addition, if one considers the inefficiencies of the turbine, then the net output will be further reduced. As a result using a turbine for extracting the work from the high pressure liquid is not economically justified in most of the cases<sup>1</sup>.

One way of achieving dry compression in Carnot refrigeration cycle is to have two compressors – one isentropic and one isothermal as shown in Fig.10.4.

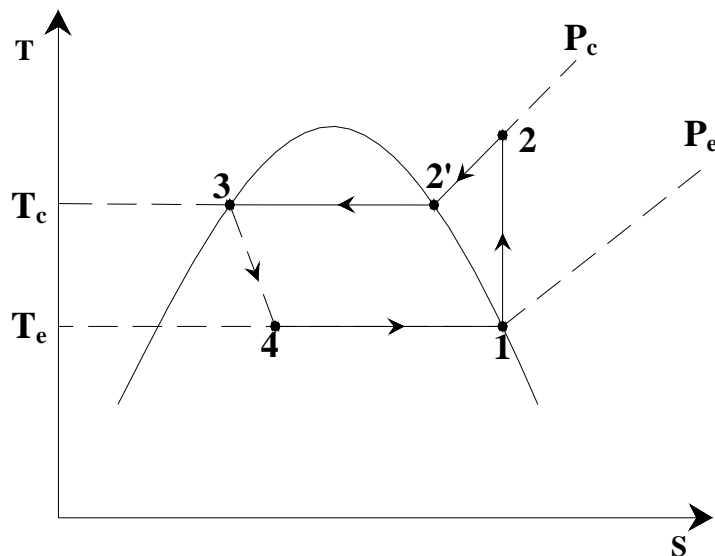
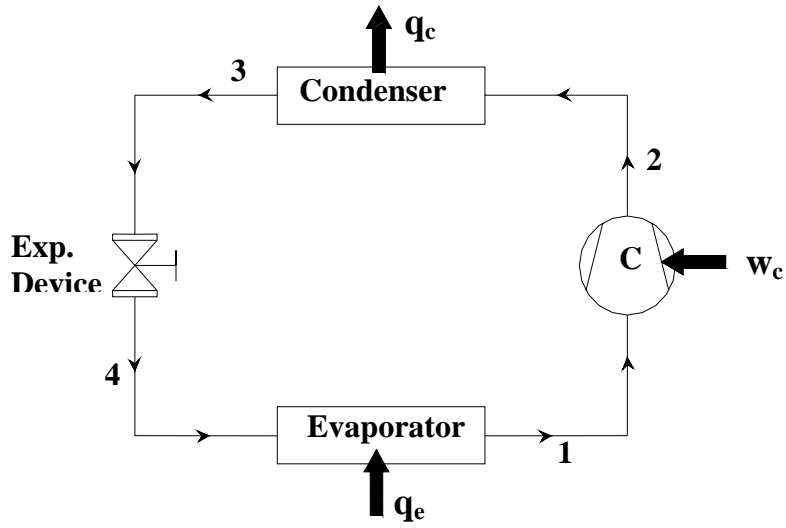


**Fig.10.4.** Carnot refrigeration system with dry compression

As shown in Fig.10.4, the Carnot refrigeration system with dry compression consists of one isentropic compression process (1-2) from evaporator pressure  $P_e$  to an intermediate pressure  $P_i$  and temperature  $T_c$ , followed by an isothermal compression process (2-3) from the intermediate pressure  $P_i$  to the condenser pressure  $P_c$ . Though with this modification the problem of wet compression can be avoided, still this modified system is not practical due to the difficulty in achieving true isothermal compression using high-speed compressors. In addition, use of two compressors in place of one is not economically justified.

<sup>1</sup> However, currently efforts are being made to recover this work of expansion in some refrigeration systems to improve the system efficiency.

From the above discussion, it is clear that from practical considerations, the Carnot refrigeration system need to be modified. Dry compression with a single compressor is possible if the isothermal heat rejection process is replaced by isobaric heat rejection process. Similarly, the isentropic expansion process can be replaced by an isenthalpic throttling process. A refrigeration system, which incorporates these two changes is known as Evans-Perkins or reverse Rankine cycle. This is the theoretical cycle on which the actual vapour compression refrigeration systems are based.



*Fig.10.5. Standard Vapour compression refrigeration system*



## 10.4. Standard Vapour Compression Refrigeration System (VCRS)

Figure 10.5 shows the schematic of a standard, saturated, single stage (SSS) vapour compression refrigeration system and the operating cycle on a T s diagram. As shown in the figure the standard single stage, saturated vapour compression refrigeration system consists of the following four processes:

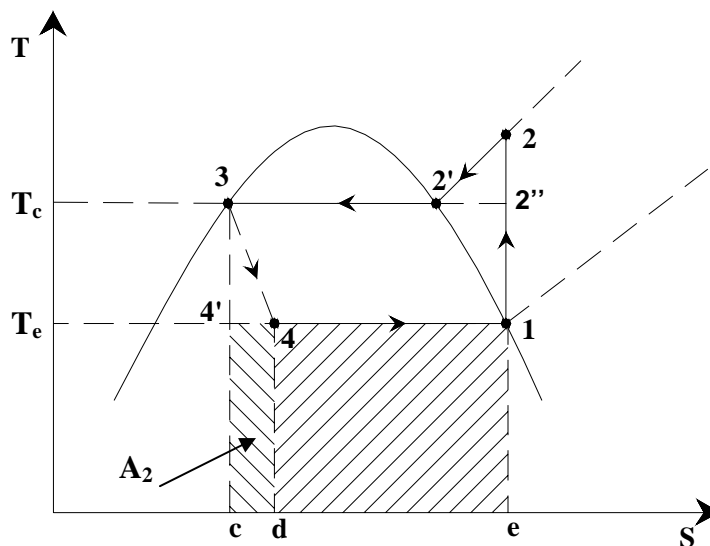
Process 1-2: Isentropic compression of saturated vapour in compressor

Process 2-3: Isobaric heat rejection in condenser

Process 3-4: Isenthalpic expansion of saturated liquid in expansion device

Process 4-1: Isobaric heat extraction in the evaporator

By comparing with Carnot cycle, it can be seen that the standard vapour compression refrigeration cycle introduces two irreversibilities: 1) Irreversibility due to non-isothermal heat rejection (process 2-3) and 2) Irreversibility due to isenthalpic throttling (process 3-4). As a result, one would expect the theoretical COP of standard cycle to be smaller than that of a Carnot system for the same heat source and sink temperatures. Due to these irreversibilities, the cooling effect reduces and work input increases, thus reducing the system COP. This can be explained easily with the help of the cycle diagrams on T s charts. Figure 10.6(a) shows comparison between Carnot and standard VCRS in terms of refrigeration effect.



*Fig.10.6(a). Comparison between Carnot and standard VCRS*

The heat extraction (evaporation) process is reversible for both the Carnot cycle and VCRS cycle. Hence the refrigeration effect is given by:

For Carnot refrigeration cycle (1-2''-3-4'):

$$q_{e,\text{Carnot}} = q_{4'-1} = \int_{4'}^1 T \cdot ds = T_e (s_1 - s_{4'}) = \text{area } e-1-4'-c-e \quad (10.7)$$

For VCRES cycle (1-2-3-4):

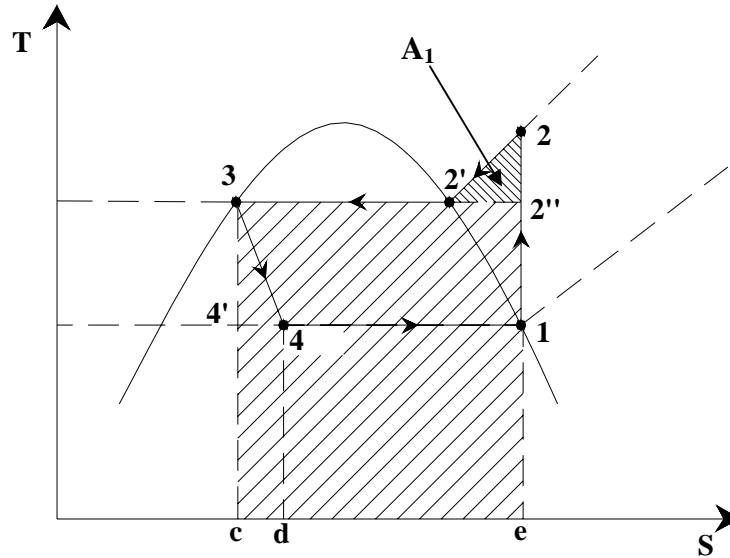
$$q_{e,VCRES} = q_{4-1} = \int_4^1 T.ds = T_e (s_1 - s_4) = \text{area } e-1-4-d-e \quad (10.8)$$

thus there is a reduction in refrigeration effect when the isentropic expansion process of Carnot cycle is replaced by isenthalpic throttling process of VCRES cycle, this reduction is equal to the area  $d-4-4'-c-d$  (area  $A_2$ ) and is known as *throttling loss*. The throttling loss is equal to the enthalpy difference between state points 3 and 4', i.e.,

$$q_{e,Carnot} - q_{VCRES} = \text{area } d-4-4'-c-d = (h_3 - h_{4'}) = (h_4 - h_{4'}) = \text{area } A_2 \quad (10.9)$$

It is easy to show that the loss in refrigeration effect increases as the evaporator temperature decreases and/or condenser temperature increases. A practical consequence of this is a requirement of higher refrigerant mass flow rate.

The heat rejection in case of VCRES cycle also increases when compared to Carnot cycle.



**Fig.10.6(b).** Comparative evaluation of heat rejection rate of VCRES and Carnot cycle

As shown in Fig.10.6(b), the heat rejection in case of Carnot cycle (1-2''-3-4') is given by:

$$q_{c,Carnot} = -q_{2''-3} = -\int_{2''}^3 T.ds = T_c (s_{2''} - s_3) = \text{area } e-2''-3-c-e \quad (10.10)$$

In case of VCRES cycle, the heat rejection rate is given by:

$$q_{c,VCRES} = -q_{2-3} = -\int_2^3 T.ds = \text{area } e-2-3-c-e \quad (10.11)$$

Hence the increase in heat rejection rate of VCRES compared to Carnot cycle is equal to the area  $2''-2-2'$  (area  $A_1$ ). This region is known as *superheat horn*, and is due to the

replacement of isothermal heat rejection process of Carnot cycle by isobaric heat rejection in case of VCRS.

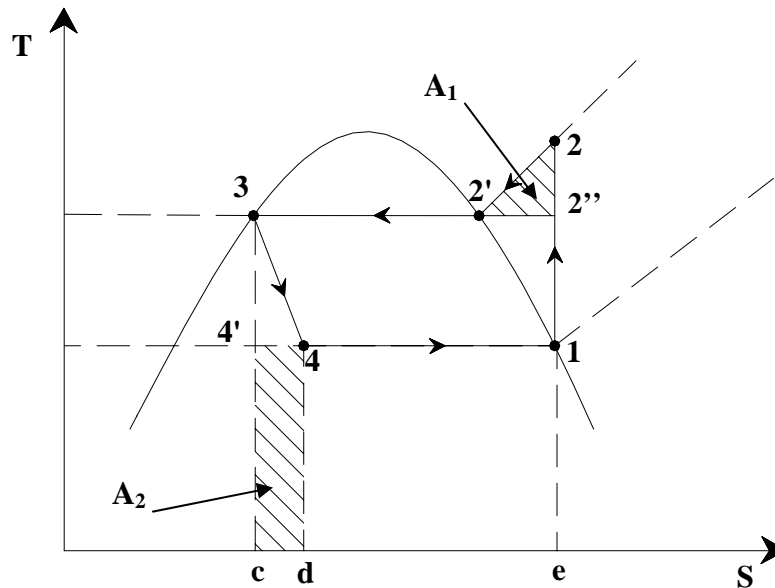
Since the heat rejection increases and refrigeration effect reduces when the Carnot cycle is modified to standard VCRS cycle, the net work input to the VCRS increases compared to Carnot cycle. The net work input in case of Carnot and VCRS cycles are given by:

$$W_{\text{net,Carnot}} = (q_c - q_e)_{\text{Carnot}} = \text{area } 1-2'-3-4'-1 \quad (10.12)$$

$$W_{\text{net,VCRS}} = (q_c - q_e)_{\text{VCRS}} = \text{area } 1-2-3-4'-c-d-4-1 \quad (10.13)$$

As shown in Fig.10.6(c), the increase in net work input in VCRS cycle is given by:

$$W_{\text{net,VCRS}} - W_{\text{net,Carnot}} = \text{area } 2'-2-2'' + \text{area } c-4'-4-d-c = \text{area } A_1 + \text{area } A_2 \quad (10.14)$$



**Fig.10.6(c).** Figure illustrating the increase in net work input in VCRS cycle

To summarize the refrigeration effect and net work input of VCRS cycle are given by:

$$q_{e,\text{VCRS}} = q_{e,\text{Carnot}} - \text{area } A_2 \quad (10.15)$$

$$W_{\text{net,VCRS}} = W_{\text{net,Carnot}} + \text{area } A_1 + \text{area } A_2 \quad (10.16)$$

The COP of VCRS cycle is given by:

$$\text{COP}_{\text{VCRS}} = \frac{q_{e,\text{VCRS}}}{W_{\text{net,VCRS}}} = \frac{q_{e,\text{Carnot}} - \text{area } A_2}{W_{\text{net,Carnot}} + \text{area } A_1 + \text{area } A_2} \quad (10.17)$$

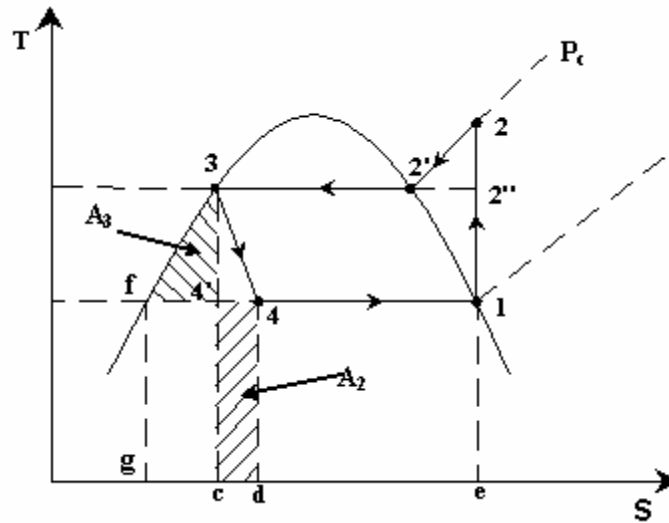
If we define the cycle efficiency,  $\eta_R$  as the ratio of COP of VCRS cycle to the COP of Carnot cycle, then:

$$\eta_R = \frac{COP_{VCRS}}{COP_{Carnot}} = \left[ \frac{1 - \left( \frac{\text{area } A_2}{q_{e,Carnot}} \right)}{1 + \left( \frac{\text{area } A_1 + \text{area } A_2}{W_{net,Carnot}} \right)} \right] \quad (10.18)$$

The cycle efficiency (also called as second law efficiency) is a good indication of the deviation of the standard VCRS cycle from Carnot cycle. Unlike Carnot COP, the cycle efficiency depends very much on the shape of T s diagram, which in turn depends on the nature of the working fluid.

If we assume that the potential and kinetic energy changes during isentropic compression process 1-2 are negligible, then the work input  $w_{1-2}$  is given by:

$$w_{1-2,VCRS} = (h_2 - h_1) = (h_2 - h_f) - (h_1 - h_f) \quad (10.19)$$



**Fig.10.7.** Figure showing saturated liquid line 3-f coinciding with the constant pressure line

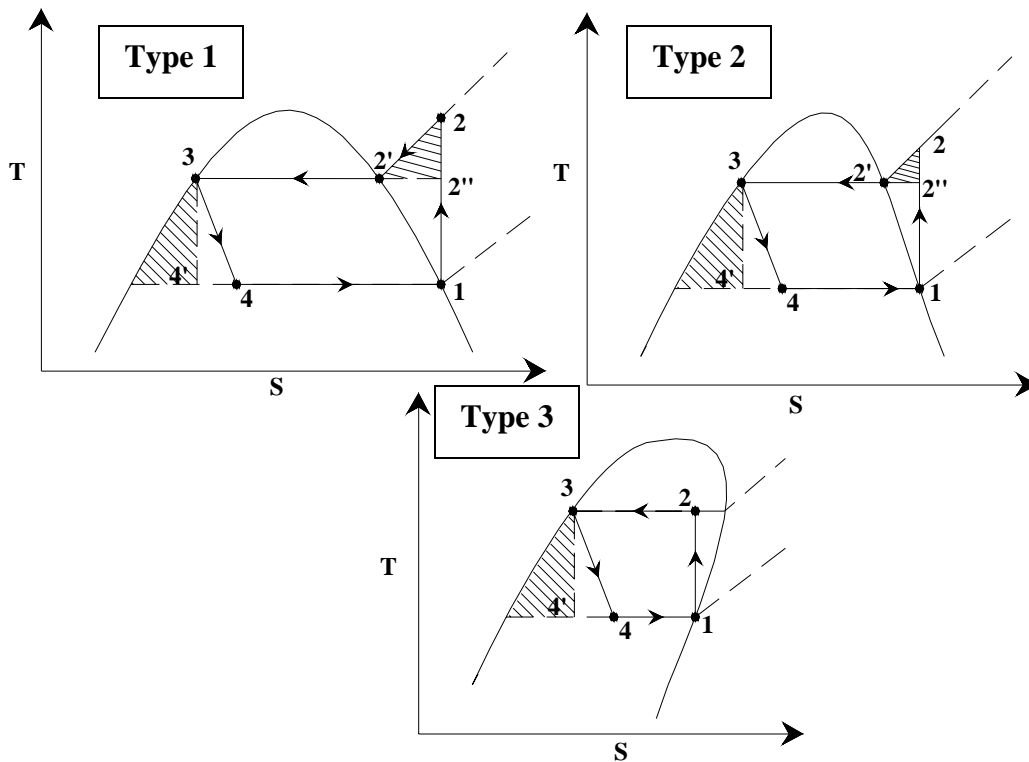
Now as shown in Fig.10.7, if we further assume that the saturated liquid line 3-f coincides with the constant pressure line  $P_c$  in the subcooled region (which is a reasonably good assumption), then from the 2<sup>nd</sup> Tds relation;

$$\begin{aligned} Tds &= dh - v dP = dh; \text{ when } P \text{ is constant} \\ \therefore (h_2 - h_f) &= \int_2^f Tds = \text{area } e-2-3-f-g-e \end{aligned} \quad (10.20)$$

$$\text{and, } (h_1 - h_f) = \int_1^f T ds = \text{area } e-1-f-g-e \quad (10.21)$$

Substituting these expressions in the expression for net work input, we obtain the compressor work input to be equal to area 1-2-3-f-1. Now comparing this with the earlier expression for work input (area 1-2-3-4'-c-d-4-1), we conclude that area  $A_2$  is equal to area  $A_3$ .

As mentioned before, the losses due to superheat (area  $A_1$ ) and throttling (area  $A_2 \approx A_3$ ) depend very much on the shape of the vapor dome (saturation liquid and vapour curves) on T s diagram. The shape of the saturation curves depends on the nature of refrigerant. Figure 10.8 shows T s diagrams for three different types of refrigerants.



**Fig.10.8.** T-s diagrams for three different types of refrigerants

Refrigerants such as ammonia, carbon di-oxide and water belong to Type 1. These refrigerants have symmetrical saturation curves (vapour dome), as a result both the superheat and throttling losses (areas  $A_1$  and  $A_3$ ) are significant. That means deviation of VCRC cycle from Carnot cycle could be significant when these refrigerants are used as working fluids. Refrigerants such as CFC11, CFC12, HFC134a belong to Type 2, these refrigerants have small superheat losses (area  $A_1$ ) but large throttling losses (area  $A_3$ ). High molecular weight refrigerants such as CFC113, CFC114, CFC115, iso-butane belonging to Type 3, do not have any superheat losses, i.e., when the compression inlet condition is saturated (point 1), then the exit condition will be in the 2-phase region, as a result it is not necessary to superheat the refrigerant. However, these refrigerants

experience significant throttling losses. Since the compressor exit condition of Type 3 refrigerants may fall in the two-phase region, there is a danger of wet compression leading to compressor damage. Hence for these refrigerants, the compressor inlet condition is chosen such that the exit condition does not fall in the two-phase region. This implies that the refrigerant at the inlet to the compressor should be superheated, the extent of which depends on the refrigerant.

### **Superheat and throttling losses:**

It can be observed from the discussions that the superheat loss is fundamentally different from the throttling loss. The superheat loss increases only the work input to the compressor, it does not effect the refrigeration effect. In heat pumps superheat is not a loss, but a part of the useful heating effect. However, the process of throttling is inherently irreversible, and it increases the work input and also reduces the refrigeration effect.

## **10.5. Analysis of standard vapour compression refrigeration system**

A simple analysis of standard vapour compression refrigeration system can be carried out by assuming a) Steady flow; b) negligible kinetic and potential energy changes across each component, and c) no heat transfer in connecting pipe lines. The steady flow energy equation is applied to each of the four components.

Evaporator: Heat transfer rate at evaporator or *refrigeration capacity*,  $\dot{Q}_e$  is given by:

$$\dot{Q}_e = \dot{m}_r (h_1 - h_4) \quad (10.22)$$

where  $\dot{m}_r$  is the refrigerant mass flow rate in kg/s,  $h_1$  and  $h_4$  are the specific enthalpies (kJ/kg) at the exit and inlet to the evaporator, respectively.  $(h_1 - h_4)$  is known as specific refrigeration effect or simply *refrigeration effect*, which is equal to the heat transferred at the evaporator per kilogram of refrigerant. The evaporator pressure  $P_e$  is the saturation pressure corresponding to evaporator temperature  $T_e$ , i.e.,

$$P_e = P_{\text{sat}}(T_e) \quad (10.23)$$

Compressor: Power input to the compressor,  $\dot{W}_c$  is given by:

$$\dot{W}_c = \dot{m}_r (h_2 - h_1) \quad (10.24)$$

where  $h_2$  and  $h_1$  are the specific enthalpies (kJ/kg) at the exit and inlet to the compressor, respectively.  $(h_2 - h_1)$  is known as specific work of compression or simply *work of compression*, which is equal to the work input to the compressor per kilogram of refrigerant.

Condenser: Heat transfer rate at condenser,  $\dot{Q}_c$  is given by:

$$\dot{Q}_c = \dot{m}_r (h_2 - h_3) \quad (10.25)$$

where  $h_3$  and  $h_2$  are the specific enthalpies (kJ/kg) at the exit and inlet to the condenser, respectively.

The condenser pressure  $P_c$  is the saturation pressure corresponding to evaporator temperature  $T_c$ , i.e.,

$$P_c = P_{\text{sat}}(T_c) \quad (10.26)$$

Expansion device: For the isenthalpic expansion process, the kinetic energy change across the expansion device could be considerable, however, if we take the control volume, well downstream of the expansion device, then the kinetic energy gets dissipated due to viscous effects, and

$$h_3 = h_4 \quad (10.27)$$

The exit condition of the expansion device lies in the two-phase region, hence applying the definition of quality (or dryness fraction), we can write:

$$h_4 = (1 - x_4)h_{f,e} + x_4h_{g,e} = h_f + x_4h_{fg} \quad (10.28)$$

where  $x_4$  is the quality of refrigerant at point 4,  $h_{f,e}$ ,  $h_{g,e}$ ,  $h_{fg}$  are the saturated liquid enthalpy, saturated vapour enthalpy and latent heat of vaporization at evaporator pressure, respectively.

The COP of the system is given by:

$$\text{COP} = \left( \frac{\dot{Q}_e}{\dot{W}_c} \right) = \left( \frac{\dot{m}_r (h_1 - h_4)}{\dot{m}_r (h_2 - h_1)} \right) = \frac{(h_1 - h_4)}{(h_2 - h_1)} \quad (10.29)$$

At any point in the cycle, the mass flow rate of refrigerant  $\dot{m}_r$  can be written in terms of volumetric flow rate and specific volume at that point, i.e.,

$$\dot{m}_r = \frac{\dot{V}}{v} \quad (10.30)$$

applying this equation to the inlet condition of the compressor,

$$\dot{m}_r = \frac{\dot{V}_1}{v_1} \quad (10.31)$$

where  $\dot{V}_1$  is the volumetric flow rate at compressor inlet and  $v_1$  is the specific volume at compressor inlet. At a given compressor speed,  $\dot{V}_1$  is an indication of the size of the compressor. We can also write, the refrigeration capacity in terms of volumetric flow rate as:

$$\dot{Q}_e = \dot{m}_r (h_1 - h_4) = \dot{V}_1 \left( \frac{h_1 - h_4}{v_1} \right) \quad (10.32)$$

where  $\left( \frac{h_1 - h_4}{v_1} \right)$  is called as *volumetric refrigeration effect* (kJ/m<sup>3</sup> of refrigerant).

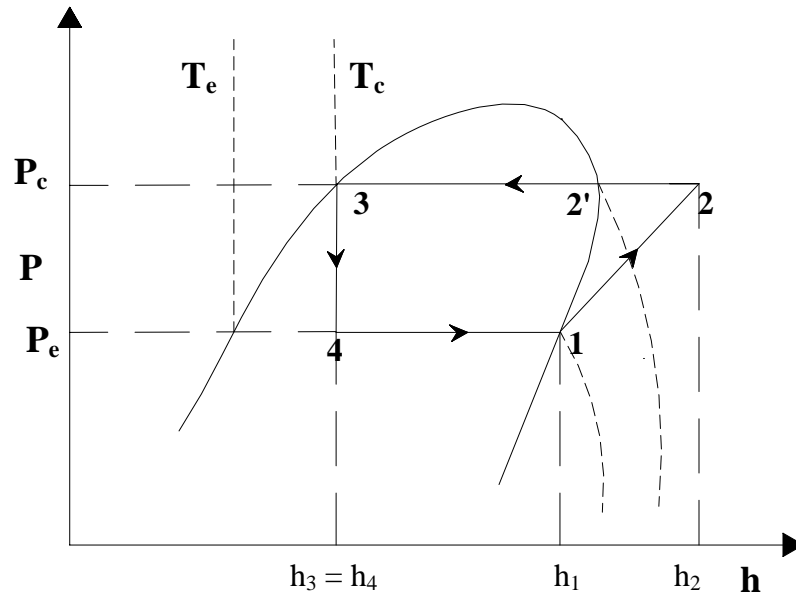
Generally, the type of refrigerant, required refrigeration capacity, evaporator temperature and condenser temperature are known. Then from the evaporator and condenser temperature one can find the evaporator and condenser pressures and enthalpies at the exit of evaporator and condenser (saturated vapour enthalpy at evaporator pressure and saturated liquid enthalpy at condenser pressure). Since the exit condition of the compressor is in the superheated region, two independent properties are required to fix the state of refrigerant at this point. One of these independent properties could be the condenser pressure, which is already known. Since the compression process is isentropic, the entropy at the exit to the compressor is same as the entropy at the inlet,  $s_1$  which is the saturated vapour entropy at evaporator pressure (known). Thus from the known pressure and entropy the exit state of the compressor could be fixed, i.e.,

$$\begin{aligned} h_2 &= h(P_c, s_2) = h(P_c, s_1) \\ s_1 &= s_2 \end{aligned} \quad (10.33)$$

The quality of refrigerant at the inlet to the evaporator ( $x_4$ ) could be obtained from the known values of  $h_3$ ,  $h_{f,e}$  and  $h_{g,e}$ .

Once all the state points are known, then from the required refrigeration capacity and various enthalpies one can obtain the required refrigerant mass flow rate, volumetric flow rate at compressor inlet, COP, cycle efficiency etc.

**Use of Pressure-enthalpy (P-h) charts:**



**Fig.10.9.** Standard vapour compression refrigeration cycle on a P-h chart



Since the various performance parameters are expressed in terms of enthalpies, it is very convenient to use a pressure – enthalpy chart for property evaluation and performance analysis. The use of these charts was first suggested by Richard Mollier. Figure 10.9 shows the standard vapour compression refrigeration cycle on a P-h chart. As discussed before, in a typical P-h chart, enthalpy is on the x-axis and pressure is on y-axis. The isotherms are almost vertical in the subcooled region, horizontal in the two-phase region (for pure refrigerants) and slightly curved in the superheated region at high pressures, and again become almost vertical at low pressures. A typical P-h chart also shows constant specific volume lines (isochors) and constant entropy lines (isentropes) in the superheated region. Using P-h charts one can easily find various performance parameters from known values of evaporator and condenser pressures.

In addition to the P-h and T-s charts one can also use thermodynamic property tables from solving problems related to various refrigeration cycles.

### Questions:

1. A Carnot refrigerator using R12 as working fluid operates between 40°C and -30°C. Determine the work of compression and cooling effect produced by the cycle. ([Solution](#))
2. An ideal refrigeration cycle operates with R134a as the working fluid. The temperature of refrigerant in the condenser and evaporator are 40°C and -20°C respectively. The mass flow rate of refrigerant is 0.1 kg/s. Determine the cooling capacity and COP of the plant. ([Solution](#))
3. A R-12 plant has to produce 10 tons of refrigeration. The condenser and evaporator temperatures are 40°C and -10°C respectively. Determine
  - a) Refrigerant flow rate
  - b) Volume flow rate of the compressor
  - c) Operating pressure ratio
  - d) Power required to drive the compressor
  - e) Flash gas percentage after throttling
  - f) COP ([Solution](#))
4. A NH<sub>3</sub> refrigerator produces 100 tons of ice from water at 0°C in a day. The cycle operates between 25°C and -15°C . The vapor is dry saturated at the end of compression. If the COP is 50% of theoretical COP, calculate the power required to drive the compressor. ([Solution](#))
5. In a refrigerator the power rating impressed on the compressor is 1.2 kW. The circulating wire in evaporator is 5 kW and the cooling water took away 10 kW from condenser coil. The operating temperatures range is 18°C and 0°C and their corresponding latent heats are 170 kJ/kg and 230 kJ/kg and the difference between the

liquid energy is 35 kJ/kg. Find the actual COP of the system (2) relative COP, assuming the vapour is just dry and saturated at the end of the compression. ([Solution](#))

6. A water cooler using R12 refrigerant works between 30°C to 9°C. Assuming the volumetric and mechanical efficiency of the compressor to be 80 and 90% respectively, and the mechanical efficiency of motor to be 90% , and 20% of useful cooling is lost into water cooler, find:

- 1) The power requirement of the motor
- 2) Volumetric displacement of the compressor

Given  $C_p$  (saturated vapour at 30°C) = 0.7 kJ/kg K ([Solution](#))

The properties of F12 at 30°C and 2°C are:

Temp °C	Pressure (Bar)	Liquid		Vapour		
		$h_f$ (kJ/kg)	$S_f$ (kJ/kg K)	$h_g$ (kJ/kg)	$S_g$ (kJ/kg K)	$v_s$ m <sup>3</sup> /kg
30	7.45	64.6	0.2399	199.6	0.6854	0.0235
5	3.626	40.7	0.1587	189.7	0.6942	0.0475

# Lesson

11

## Vapour Compression Refrigeration Systems: Performance Aspects And Cycle Modifications

## The objectives of this lecture are to discuss

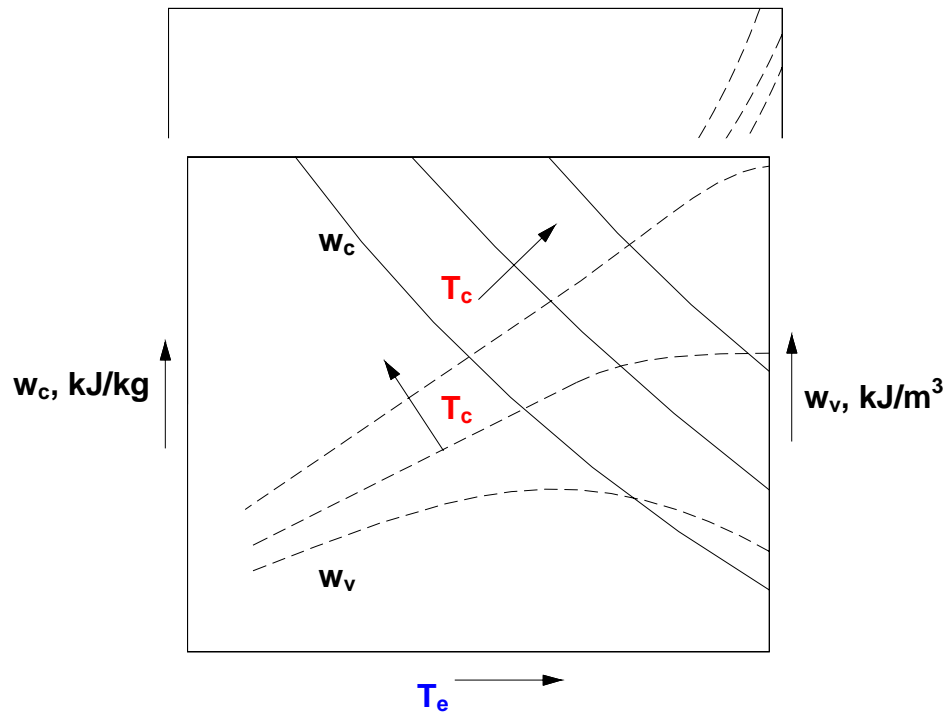
1. Performance aspects of SSS cycle and the effects of evaporator and condensing temperatures on system performance (*Section 11.1*)
2. Modifications to the basic SSS cycle by way of subcooling and superheating and effects of these modifications on system performance (*Section 11.2.1*)
3. Performance aspects of single stage VCRS cycle with Liquid-to-Suction Heat Exchanger and the concept of Grindley's cycle (*Section 11.2.2*)
4. Effect of superheat and criteria for optimum superheat (*Section 11.3*)
5. Actual vapour compression refrigeration systems (*Section 11.4*)
6. Complete vapour compression refrigeration systems (*Section 11.5*)

At the end of the lecture the student should be able to:

1. Show and discuss qualitatively the effects of evaporator and condensing temperatures on specific and volumic refrigeration effects, on specific and volumic work of compression and on system COP
2. Discuss and evaluate the performance of single stage VCRS with subcooling and superheating from given inputs and known refrigerant property data
3. Evaluate the performance of the system with a LSHX
4. Establish the existence of optimum superheat condition using Ewings-Gosney criteria
5. Evaluate the COP of actual VCRS from condensing and evaporator temperatures, efficiency of motor and compressor
6. Draw an actual VCRS cycle on T-s and P-h diagrams and discuss the effects of various irreversibilities due to pressure drops, heat transfer and non-ideal compression
7. Describe briefly a complete vapour compression refrigeration system

### 11.1. Performance of SSS cycle

The performance of a standard VCRS cycle can be obtained by varying evaporator and condensing temperatures over the required range. Figure 11.1 shows the effects of evaporator and condensing temperatures on specific and volumic refrigeration effects of a standard VCRS cycle. As shown in the figure, for a given condenser temperature as evaporator temperature increases the specific refrigeration effect increases marginally. It can be seen that for a given evaporator temperature, the refrigeration effect decreases as condenser temperature increases. These trends can be explained easily with the help of the P-h diagram. It can also be observed that the volumetric refrigeration effect increases rapidly with evaporator temperature due to the increase in specific refrigeration effect and decrease in specific volume of refrigerant vapour at the inlet to the compressor. Volumetric refrigeration effect increases marginally as condenser temperature decreases.

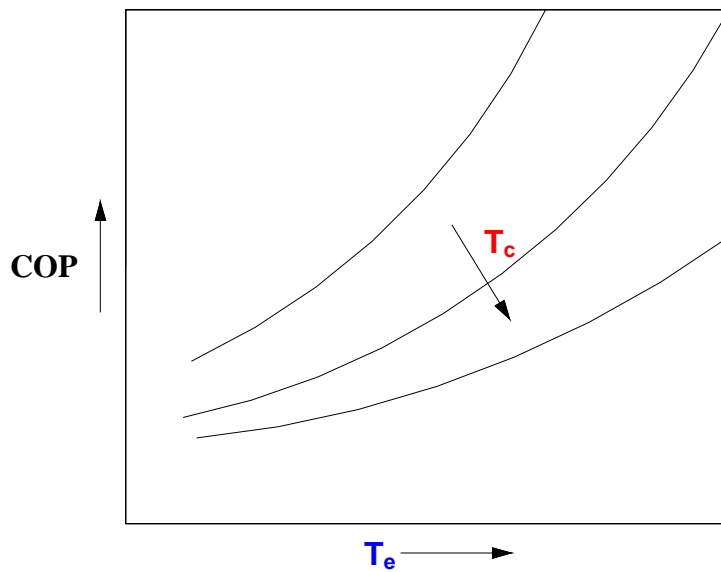


**Fig.11.2: Effect of evaporator and condenser temperatures on specific and volumic works of compression of a standard VCRS cycle**

Figure 11.2 shows that the specific work of compression decreases rapidly as the evaporator temperature increases and condenser temperature decreases. Once again these effects can be explained using a T s or P h diagram. For a given condenser temperature, the volumic work of compression increases initially, reaches a peak, then starts decreasing. This is due to the fact that as evaporator temperature increases the specific work of compression decreases and the specific volume at the inlet to the compressor also decreases. As a result, an optimum evaporator temperature exists at which the volumic work of compression reaches a maximum. Physically, the volumic work of compression is analogous to mean effective pressure of the compressor, as multiplying this with the volumetric flow rate gives the power input to the compressor. For a given power input, a high volumic work of compression implies smaller volumetric flow rates and hence a smaller compressor.

Figure 11.3 shows the effect of evaporator and condenser temperatures on COP of the SSS cycle. As expected, for a given condenser temperature the COP increases rapidly with evaporator temperature, particularly at low condensing temperatures. For a given evaporator temperature, the COP decreases as condenser temperature increases. However, the effect of condenser temperature becomes marginal at low evaporator temperatures.

The above results show that at very low evaporator temperatures, the COP becomes very low and also the size of the compressor becomes large (due to small volumic refrigeration effect). It can also be shown that the compressor discharge temperatures also increase as the evaporator temperature decreases. Hence, single stage vapour compression refrigeration systems are not viable for very low evaporator temperatures. One has to use multistage or cascade systems for these applications. These systems will be discussed in the next lecture. One can also observe the similarities in performance trends between SSS cycle and Carnot cycle, which is to be expected as the VCRS cycle is obtained by modifying the SSS cycle.



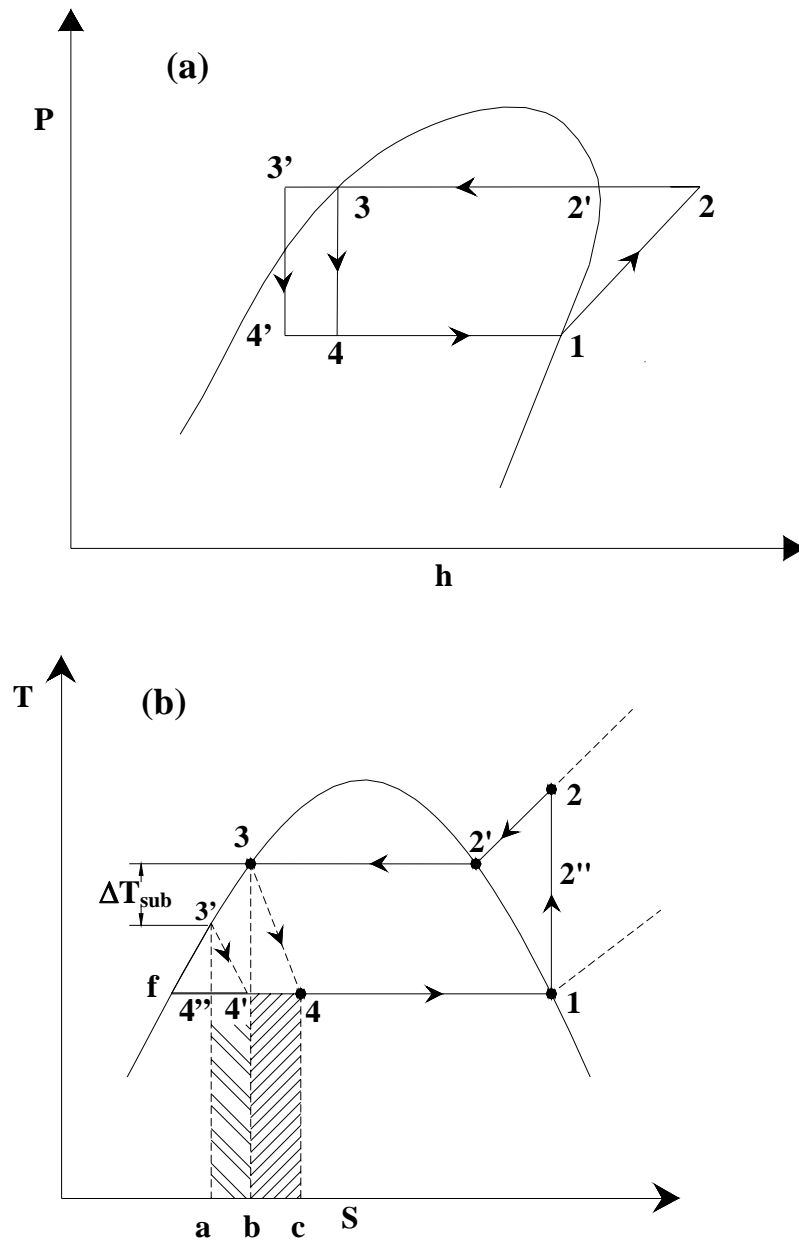
**Fig.11.3:** Effect of evaporator and condenser temperatures on COP of a standard VCRS cycle

## 11.2. Modifications to SSS cycle

### 11.2.1. Subcooling and superheating:

In actual refrigeration cycles, the temperature of the heat sink will be several degrees lower than the condensing temperature to facilitate heat transfer. Hence it is possible to cool the refrigerant liquid in the condenser to a few degrees lower than the condensing temperature by adding extra area for heat transfer. In such a case, the exit condition of the condenser will be in the subcooled liquid region. Hence this process is known as *subcooling*. Similarly, the temperature of heat source will be a few degrees higher than the evaporator temperature, hence the vapour at the exit of the evaporator can be superheated by a few degrees. If the superheating of refrigerant takes place due to heat transfer with the refrigerated space (low temperature heat source) then it is called as *useful superheating* as it increases the refrigeration effect. On the other hand, it is possible for the refrigerant vapour to become superheated by exchanging heat with the surroundings as it flows through the connecting pipelines. Such a superheating is called as useless superheating as it does not increase refrigeration effect.

Subcooling is beneficial as it increases the refrigeration effect by reducing the throttling loss at no additional specific work input. Also subcooling ensures that only liquid enters into the throttling device leading to its efficient operation. Figure 11.4 shows the VCRS cycle without and with subcooling on P-h and T-s coordinates. It can be seen from the T-s diagram that without subcooling the throttling loss is equal to the hatched area **b-4'-4-c**, whereas with subcooling the throttling loss is given by the area **a-4''-4'-b**. Thus the refrigeration effect increases by an amount equal to  $(h_4 - h_4') = (h_3 - h_3')$ . Another practical advantage of subcooling is that there is less vapour at the inlet to the evaporator which leads to lower pressure drop in the evaporator.

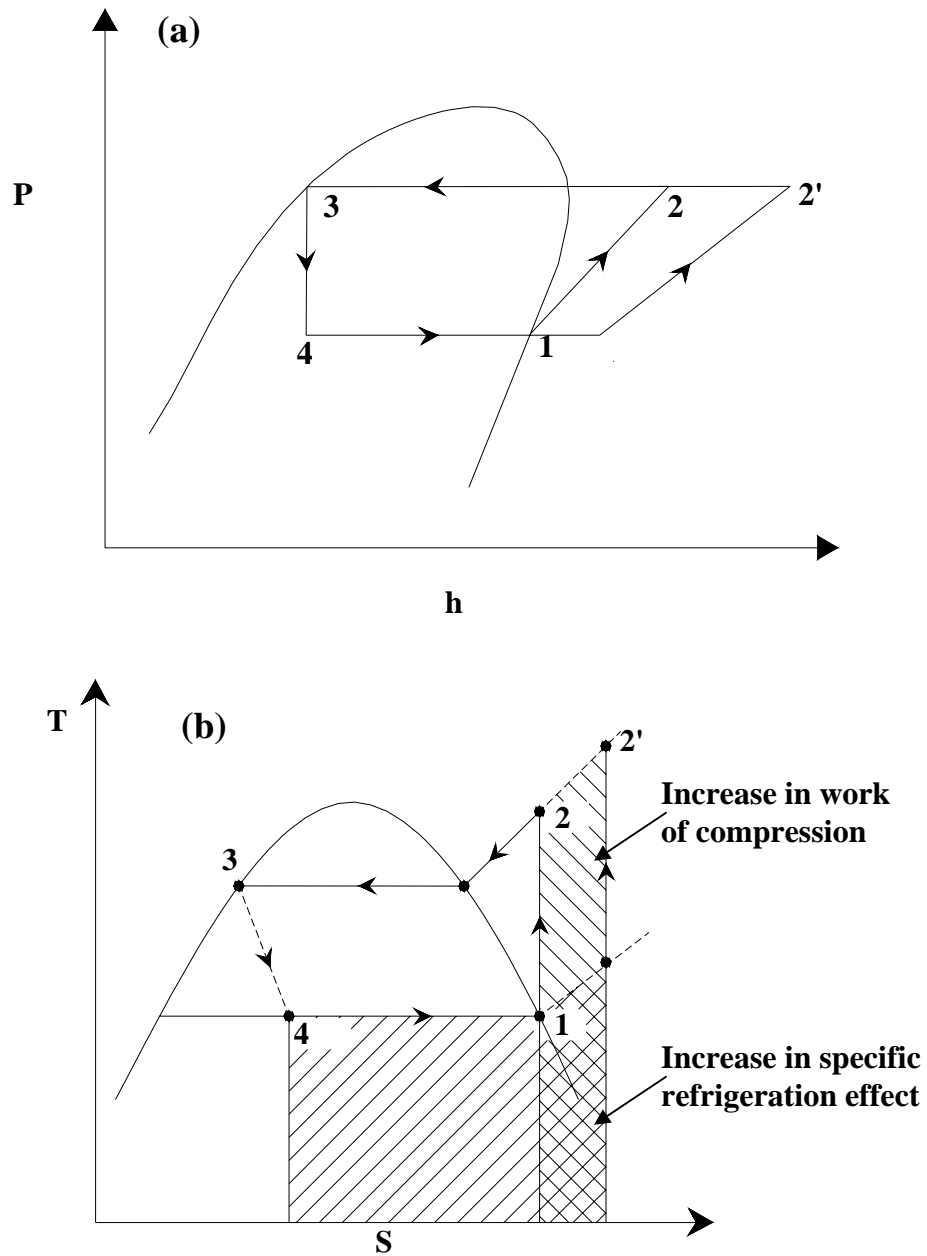


**Fig.11.4:** Comparison between a VCRES cycle without and with subcooling  
 (a) on P-h diagram (b) on T-s diagram

Useful superheating increases both the refrigeration effect as well as the work of compression. Hence the COP (ratio of refrigeration effect and work of compression) may or may not increase with superheat, depending mainly upon the nature of the working fluid. Even though useful superheating may or may not increase the COP of the system, a minimum amount of superheat is desirable as it prevents the entry of liquid droplets into the compressor. Figure 11.5 shows the VCRES cycle with superheating on P-h and T-s coordinates. As shown in the figure, with useful superheating, the refrigeration effect, specific volume at the inlet to the compressor and work of compression increase. Whether the volumic refrigeration effect (ratio of refrigeration effect by specific volume at compressor inlet) and COP increase or not depends upon the relative increase in refrigeration effect and work of compression, which in turn depends upon the nature of



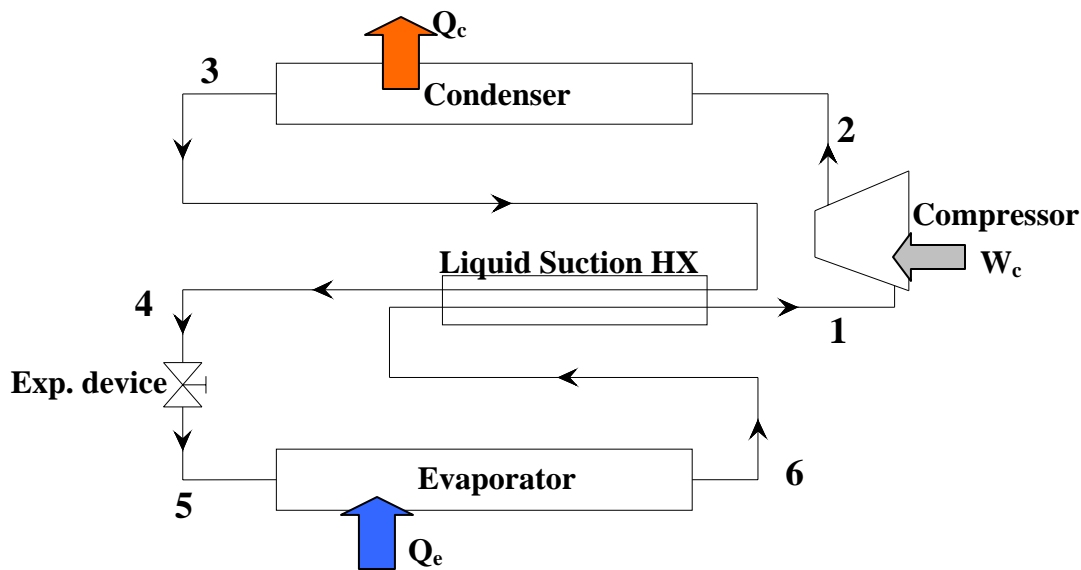
the refrigerant used. The temperature of refrigerant at the exit of the compressor increases with superheat as the isentropes in the vapour region gradually diverge.



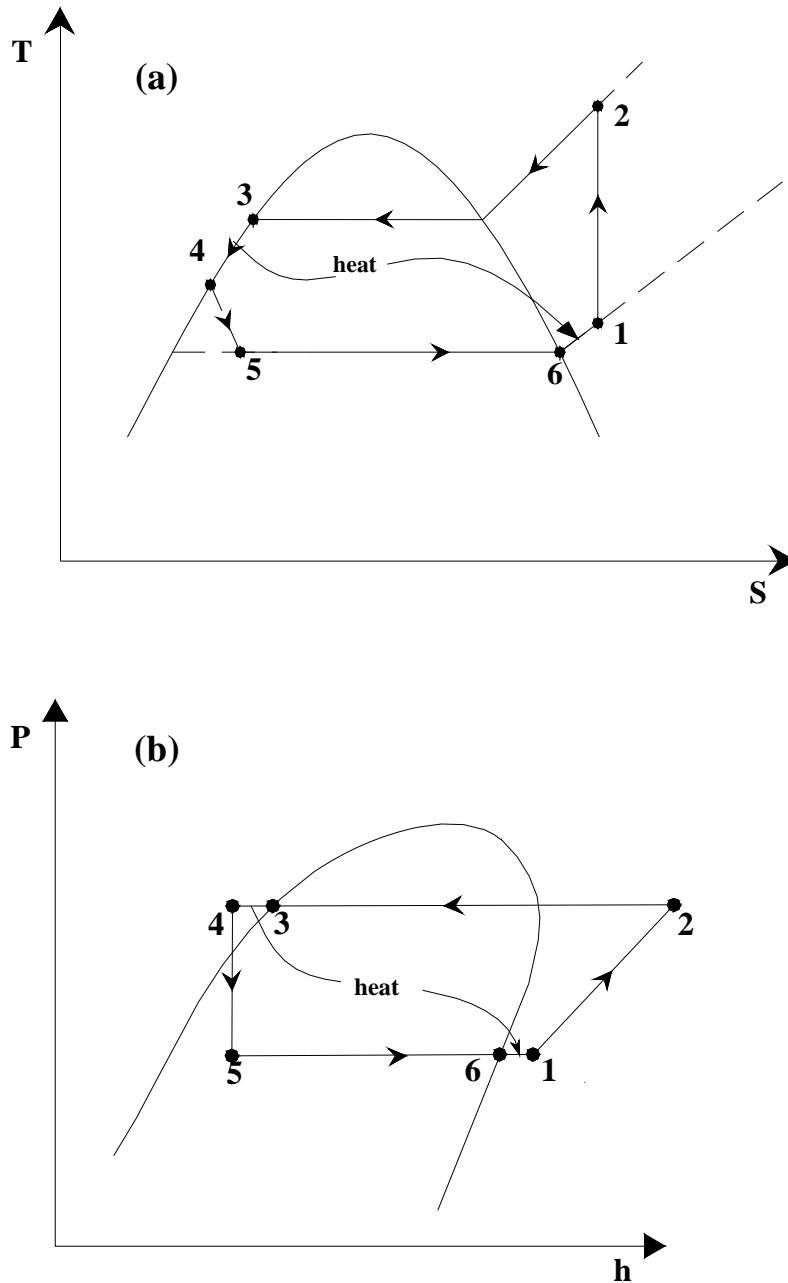
**Fig.11.5:** Effect of superheat on specific refrigeration effect and work of compression (a) on  $P-h$  diagram (b) on  $T-s$  diagram

### 11.2.2. Use of liquid-suction heat exchanger:

Required degree of subcooling and superheating may not be possible, if one were to rely only on heat transfer between the refrigerant and external heat source and sink. Also, if the temperature of refrigerant at the exit of the evaporator is not sufficiently superheated, then it may get superheated by exchanging heat with the surroundings as it flows through the connecting pipelines (useless superheating), which is detrimental to system performance. One way of achieving the required amount of subcooling and superheating is by the use of a liquid-suction heat exchanger (LSHX). A LSHX is a counterflow heat exchanger in which the warm refrigerant liquid from the condenser exchanges heat with the cool refrigerant vapour from the evaporator. Figure 11.6 shows the schematic of a single stage VCRES with a liquid-suction heat exchanger. Figure 11.7 shows the modified cycle on T-s and P-h diagrams. As shown in the T-s diagram, since the temperature of the refrigerant liquid at the exit of condenser is considerably higher than the temperature of refrigerant vapour at the exit of the evaporator, it is possible to subcool the refrigerant liquid and superheat the refrigerant vapour by exchanging heat between them.



*Fig.11.6: A single stage VCRES system with Liquid-to-Suction Heat Exchanger (LSHX)*



**Fig.11.7:** Single stage VCRES cycle with LSHX (a) on T-s diagram; (b) on P-h diagram

If we assume that there is no heat exchange between the surroundings and the LSHX and negligible kinetic and potential energy changes across the LSHX, then, the heat transferred between the refrigerant liquid and vapour in the LSHX,  $Q_{LSHX}$  is given by:

$$\begin{aligned}\dot{Q}_{\text{LSHX}} &= \dot{m}_r (h_3 - h_4) = \dot{m}_r (h_1 - h_6) \\ \Rightarrow (h_3 - h_4) &= (h_1 - h_6)\end{aligned}\tag{11.1}$$

if we take average values of specific heats for the vapour and liquid, then we can write the above equation as;

$$c_{p,l}(T_3 - T_4) = c_{p,v}(T_1 - T_6)\tag{11.2}$$

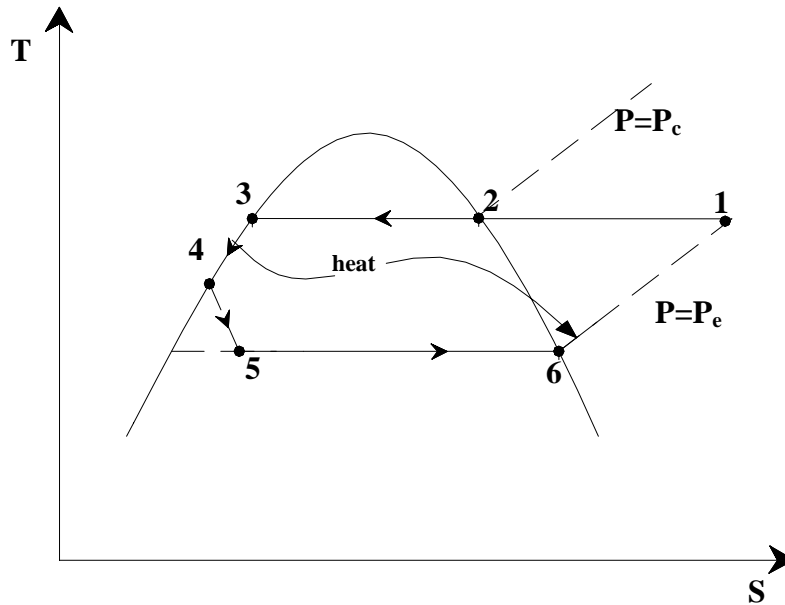
since the specific heat of liquid ( $c_{p,l}$ ) is larger than that of vapour ( $c_{p,v}$ ), i.e.,  $c_{p,l} > c_{p,v}$ , we can write:

$$(T_3 - T_4) < (T_1 - T_6)\tag{11.3}$$

This means that, the degree of subcooling ( $T_3 - T_4$ ) will always be less than the degree of superheating, ( $T_1 - T_6$ ). If we define the effectiveness of the LSHX,  $\epsilon_{\text{LSHX}}$  as the ratio of actual heat transfer rate in the LSHX to maximum possible heat transfer rate, then:

$$\epsilon_{\text{LSHX}} = \frac{Q_{\text{act}}}{Q_{\text{max}}} = \frac{\dot{m}_r c_{p,v}(T_1 - T_6)}{\dot{m}_r c_{p,v}(T_3 - T_6)} = \frac{(T_1 - T_6)}{(T_3 - T_6)}\tag{11.4}$$

The maximum possible heat transfer rate is equal to  $Q_{\text{max}} = \dot{m}_r c_{p,v}(T_3 - T_6)$ , because the vapour has a lower thermal capacity, hence only it can attain the maximum possible temperature difference, which is equal to  $(T_3 - T_6)$ . If we have a perfect LSHX with 100 percent effectiveness ( $\epsilon_{\text{LSHX}} = 1.0$ ), then from the above discussion it is clear that the temperature of the refrigerant vapour at the exit of LSHX will be equal to the condensing temperature,  $T_c$ , i.e., ( $T_1 = T_3 = T_c$ ). This gives rise to the possibility of an interesting cycle called as **Grindley cycle**, wherein the isentropic compression process can be replaced by an isothermal compression leading to improved COP. The Grindley cycle on T-s diagram is shown in Fig.11.8. Though theoretically the Grindley cycle offers higher COP, achieving isothermal compression with modern high-speed reciprocating and centrifugal compressors is difficult in practice. However, this may be possible with screw compressor where the lubricating oil provides large heat transfer rates.



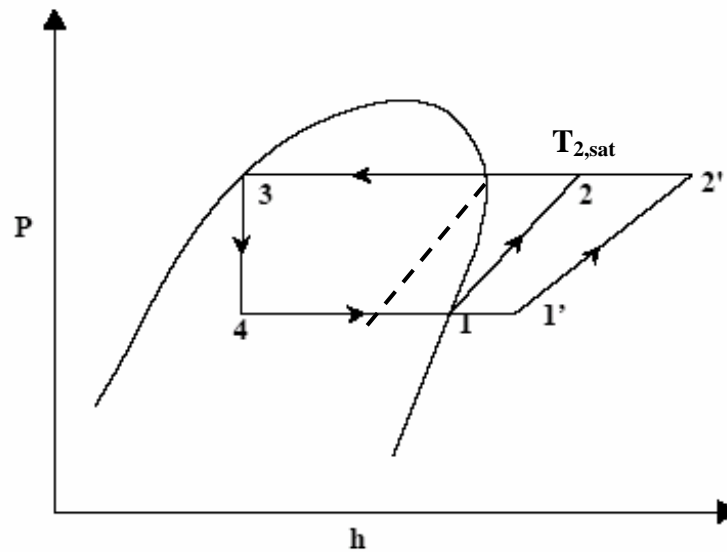
*Fig.11.8: Grindley cycle on T-s coordinates (1-2 is isothermal compression)*

### 11.3 Effect of superheat on system COP

As mentioned before, when the refrigerant is superheated usefully (either in the LSHX or the evaporator itself), the refrigeration effect increases. However, at the same time the work of compression also increases, primarily due to increase in specific volume of the refrigerant due to superheat. As a result, the volumic refrigeration effect and COP may increase or decrease with superheating depending on the relative increase in refrigeration effect and specific volume. It is observed that for some refrigerants the COP is maximum when the inlet to the compressor is inside the two-phase region and decreases as the suction condition moves into the superheated region. For other refrigerants the COP does not reach a maximum and increases monotonically with superheat. It was shown by Ewing and Gosney that a maximum COP occurs inside the two-phase region if the following criterion is satisfied:

$$\text{COP}_{\text{sat}} > \frac{T_e}{T_{2,\text{sat}} - T_e} \quad (11.5)$$

where  $\text{COP}_{\text{sat}}$  is the COP of the system with saturated suction condition,  $T_e$  is the evaporator temperature and  $T_{2,\text{sat}}$  is the compressor discharge temperature when the vapour at suction condition is saturated (see Fig.11.9). For example, at an evaporator temperature of  $-15^\circ\text{C}$  (258 K) and a condenser temperature of  $30^\circ\text{C}$  (303 K), the Table 11.1 shows that for refrigerants such as R11, R22, ammonia the maximum COP occurs inside the two-phase region and superheating reduces the COP and also volumic refrigeration effect, whereas for refrigerants such as R12, carbon dioxide and R502, no maxima exists and the COP and volumic refrigeration effect increase with superheat.



*Fig.11.9: Ewing-Gosney criteria for optimum suction condition*

Refrigerant	$COP_{sat}$	$T_{2,sat}$ (K)	$\frac{T_e}{T_{2,sat} - T_e}$	Maximum COP
Ammonia	4.77	372	2.26	Yes
CO <sub>2</sub>	2.72	341	3.11	No
R11	5.03	317	4.38	Yes
R12	4.70	311	4.87	No
R22	4.66	326	3.80	Yes
R502	4.35	310	4.96	No

*Table 11.1. Existence of maximum COP,  $T_e = 258$  K,  $T_c = 303$  K (Gosney)*

It should be noted that the above discussion holds under the assumption that the superheat is a useful superheat. Even though superheat appears to be not desirable for refrigerants such as ammonia, still a minimum amount of superheat is provided even for these refrigerants to prevent the entry of refrigerant liquid into the compressor. Also it is observed experimentally that some amount of superheat is good for the volumetric efficiency of the compressor, hence in practice almost all the systems operate with some superheat.

## 11.4 Actual VCRS systems

The cycles considered so far are internally reversible and no change of refrigerant state takes place in the connecting pipelines. However, in actual VCRS several irreversibilities exist. These are due to:

1. Pressure drops in evaporator, condenser and LSHX
2. Pressure drop across suction and discharge valves of the compressor
3. Heat transfer in compressor
4. Pressure drop and heat transfer in connecting pipe lines

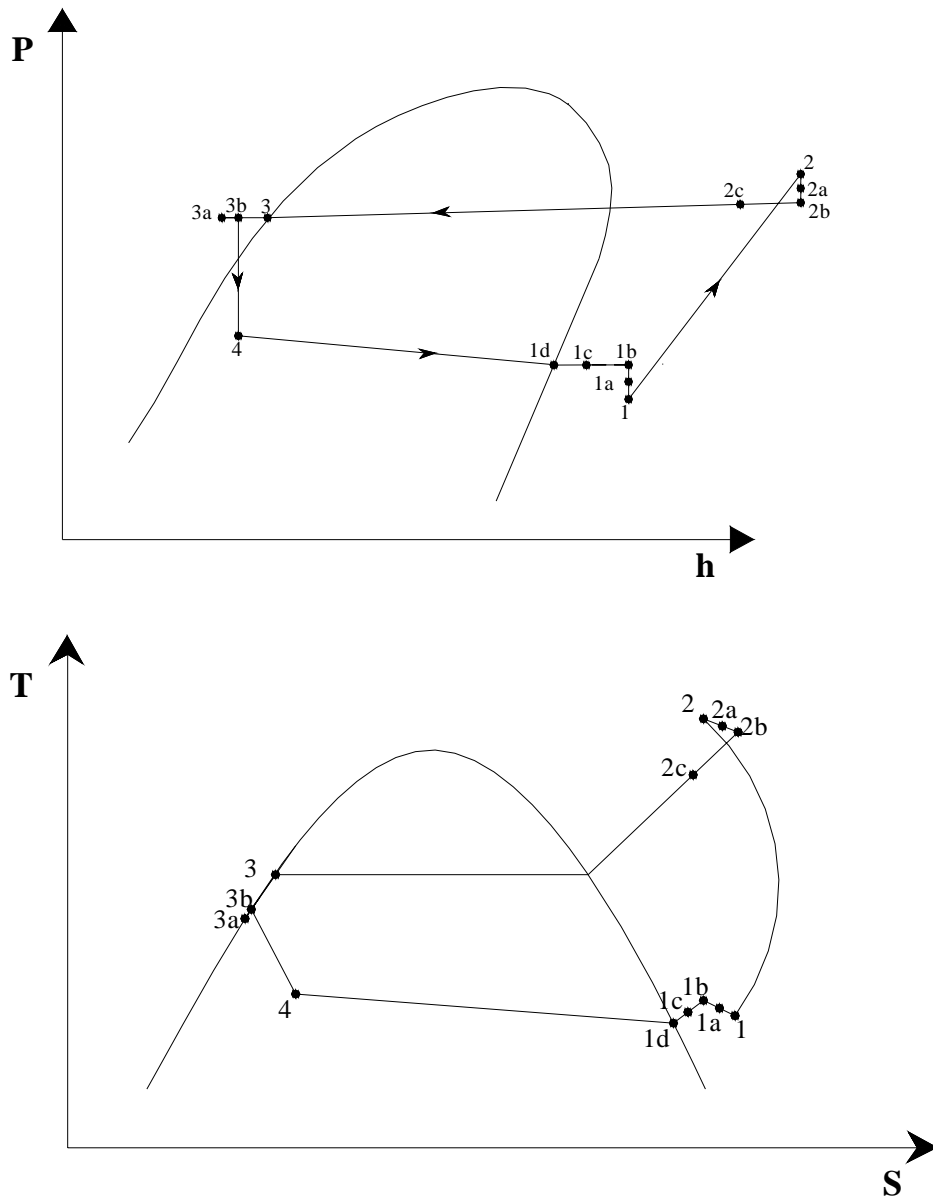
Figure 11.10 shows the actual VCRS cycle on P-h and T-s diagrams indicating various irreversibilities. From performance point of view, the pressure drop in the evaporator, in the suction line and across the suction valve has a significant effect on system performance. This is due to the reason that as suction side pressure drop increases the specific volume at suction, compression ratio (hence volumetric efficiency) and discharge temperature increase. All these effects lead to reduction in system capacity, increase in power input and also affect the life of the compressor due to higher discharge temperature. Hence this pressure drop should be as small as possible for good performance. The pressure drop depends on the refrigerant velocity, length of refrigerant tubing and layout (bends, joints etc.). Pressure drop can be reduced by reducing refrigerant velocity (e.g. by increasing the inner diameter of the refrigerant tubes), however, this affects the heat transfer coefficient in evaporator. More importantly a certain minimum velocity is required to carry the lubricating oil back to the compressor for proper operation of the compressor.

Heat transfer in the suction line is detrimental as it reduces the density of refrigerant vapour and increases the discharge temperature of the compressor. Hence, the suction lines are normally insulated to minimize heat transfer.

In actual systems the compression process involves frictional effects and heat transfer. As a result, it cannot be reversible, adiabatic (eventhough it can be isentropic). In many cases cooling of the compressor is provided deliberately to maintain the maximum compressor temperature within safe limits. This is particularly true in case of refrigerants such as ammonia. Pressure drops across the valves of the compressor increase the work of compression and reduce the volumetric efficiency of the compressor. Hence they should be as small as possible.

Compared to the vapour lines, the system is less sensitive to pressure drop in the condenser and liquid lines. However, this also should be kept as low as possible. Heat transfer in the condenser connecting pipes is not detrimental in case of refrigeration systems. However, heat transfer in the subcooled liquid lines may affect the performance.

In addition to the above, actual systems are also different from the theoretical cycles due to the presence of foreign matter such as lubricating oil, water, air, particulate matter inside the system. The presence of lubricating oil cannot be avoided, however, the system design must ensure that the lubricating oil is carried over properly to the compressor. This depends on the miscibility of refrigerant-lubricating oil. Presence of other foreign materials such as air (non-condensing gas), moisture, particulate matter is detrimental to system performance. Hence systems are designed and operated such that the concentration of these materials is as low as possible.



**Fig.11.10:** Actual VCRES cycle on P-h and T-s diagrams

Process	State
Pressure drop in evaporator	4-1d
Superheat of vapour in evaporator	1d-1c
Useless superheat in suction line	1c-1b
Suction line pressure drop	1b-1a
Pressure drop across suction valve	1a-1
Non-isentropic compression	1-2
Pressure drop across discharge valve	2-2a
Pressure drop in the delivery line	2a-2b
Desuperheating of vapour in delivery pipe	2b-2c
Pressure drop in the condenser	2b-3
Subcooling of liquid refrigerant	3-3a
Heat gain in liquid line	3a-3b



The COP of actual refrigeration systems is sometimes written in terms of the COP of Carnot refrigeration system operating between the condensing and evaporator temperatures ( $\text{COP}_{\text{Carnot}}$ ), cycle efficiency ( $\eta_{\text{cyc}}$ ), isentropic efficiency of the compressor ( $\eta_{\text{is}}$ ) and efficiency of the electric motor ( $\eta_{\text{motor}}$ ), as given by the equation shown below:

$$\text{COP}_{\text{act}} = \eta_{\text{cyc}} \eta_{\text{is}} \eta_{\text{motor}} \text{COP}_{\text{Carnot}} \quad (11.6)$$

An approximate expression for cycle efficiency ( $\eta_{\text{cyc}}$ ) in the evaporator temperature range of  $-50^{\circ}\text{C}$  to  $+40^{\circ}\text{C}$  and condensing temperature range of  $+10^{\circ}\text{C}$  to  $+60^{\circ}\text{C}$  for refrigerants such as ammonia, R 12 and R 22 is suggested by Linge in 1966. This expression for a refrigeration cycle operating without ( $\Delta T_{\text{sub}} = 0$ ) and with subcooling ( $\Delta T_{\text{sub}} = T_{\text{c}} - T_{\text{r,exit}} > 0 \text{ K}$ ) are given in Eqns. (11.7) and (11.8), respectively:

$$\eta_{\text{cyc}} = \left( 1 - \frac{T_{\text{c}} - T_{\text{e}}}{265} \right) \text{ without subcooling} \quad (11.7)$$

$$\eta_{\text{cyc}} = \left( 1 - \frac{T_{\text{c}} - T_{\text{e}}}{265} \right) \left( 1 + \frac{\Delta T_{\text{sub}}}{250} \right) \text{ with subcooling} \quad (11.8)$$

In the above equations  $T_{\text{c}}$  and  $T_{\text{e}}$  are condensing and evaporator temperatures, respectively.

The isentropic efficiency of the compressor ( $\eta_{\text{is}}$ ) depends on several factors such as the compression ratio, design of the compressor, nature of the working fluid etc. However, in practice its value generally lies between 0.5 to 0.8. The motor efficiency ( $\eta_{\text{motor}}$ ) depends on the size and motor load. Generally the motor efficiency is maximum at full load. At full load its value lies around 0.7 for small motors and about 0.95 for large motors.

## 11.5 Complete vapour compression refrigeration systems

In addition to the basic components, an actual vapour compression refrigeration consists of several accessories for safe and satisfactory functioning of the system. These include: compressor controls and safety devices such as overload protectors, high and low pressure cutouts, oil separators etc., temperature and flow controls, filters, driers, valves, sight glass etc. Modern refrigeration systems have automatic controls, which do not require continuous manual supervision.

## Questions:

1. For the same condensing temperature and refrigeration capacity, a vapour compression refrigeration system operating at a lower evaporator temperature is more expensive than a system operating at a higher evaporator temperature, because at low evaporator temperature:

- a) Volumic refrigeration effect is high, hence the size of the compressor is large
- b) Volumic refrigeration effect is small, hence the size of the compressor is large
- c) Specific refrigeration effect is high, hence size of evaporator is large
- d) All the above

**Ans.: b)**

2. For a given condensing temperature, the volumic work of compression of a standard VCRS increases initially with evaporator temperature reaches a maximum and then starts decreasing, this is because as evaporator increases:

- a) Both specific volume of refrigerant and work of compression increase
- b) Specific volume of refrigerant increases and work of compression decreases
- c) Both specific volume and work of compression decrease
- d) Specific volume decreases and specific refrigeration effect increases

**Ans.: c)**

3. Subcooling is beneficial as it:

- a) Increases specific refrigeration effect
- b) Decreases work of compression
- c) Ensures liquid entry into expansion device
- d) All of the above

**Ans.: a) and c)**

4. Superheating:

- a) Always increases specific refrigeration effect
- b) Always decreases specific work of compression
- c) Always increases specific work of compression
- d) Always increases compressor discharge temperature

**Ans.: c) and d)**

5. Degree of superheating obtained using a LSHX is:

- a) Always greater than the degree of subcooling
- b) Always less than degree of subcooling
- c) Always equal to degree of subcooling
- d) Depends on the effectiveness of heat exchanger

**Ans.: a)**

6. Whether the maximum COP occurs when the suction condition is in two-phase region or not depends mainly on:

- a) Properties of the refrigerant
- b) Effectiveness of LSHX
- c) Operating temperatures
- d) All of the above

**Ans.: a)**

7. In actual VCRS, the system performance is affected mainly by:

- a) Pressure drop and heat transfer in suction line
- b) Pressure drop and heat transfer in discharge line
- c) Heat transfer in compressor
- d) All of the above

**Ans.: a)**

8. Pressure drop and heat transfer in suction line:

- a) Decrease compression ratio & discharge temperature
- b) Increase compression ratio & discharge temperature
- c) Decreases specific volume of refrigerant at suction
- d) Increases specific volume of refrigerant at suction

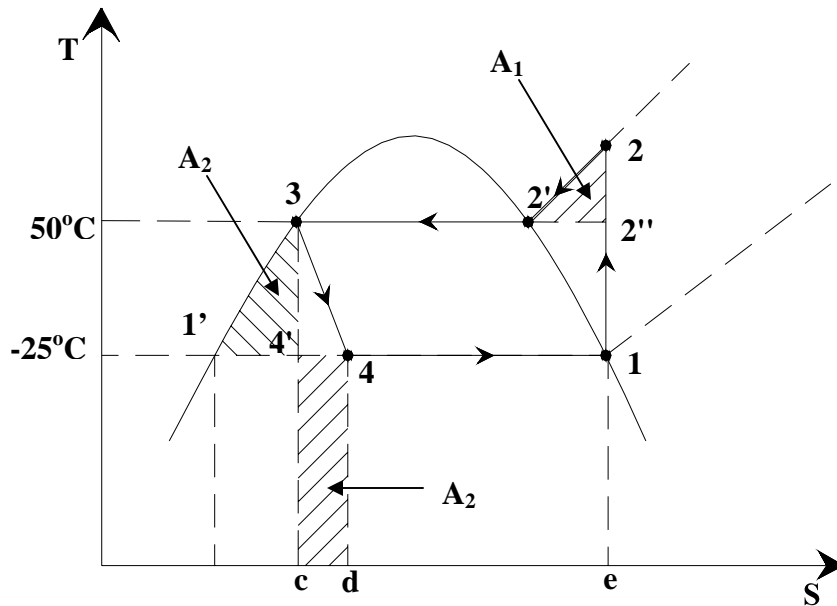
**Ans.: b) and d)**

9. A SSS vapour compression refrigeration system based on refrigerant R 134a operates between an evaporator temperature of  $-25^{\circ}\text{C}$  and a condenser temperature of  $50^{\circ}\text{C}$ . Assuming isentropic compression, find:

- a) COP of the system
- b) Work input to compressor
- c) Area of superheat horn (additional work required due to superheat)

Throttling loss (additional work input due to throttling in place of isentropic expansion) assuming the isobar at condenser pressure to coincide with saturated liquid line.

**Ans.: Given:** Refrigerant : R 134a  
 $T_e$  =  $-25^{\circ}\text{C}$   
 $T_c$  =  $50^{\circ}\text{C}$



Using refrigerant R134a property data, required properties at various state points are:

State Point	T (°C)	P (bar)	h (kJ/kg)	s (kJ/kg.K)	Quality
1	-25.0	1.064	383.4	1.746	1.0
2	<b>60.7</b>	13.18	436.2	1.746	Superheated
3	50.0	13.18	271.6	1.237	0.0
4	-25.0	1.064	271.6	<b>1.295</b>	<b>0.4820</b>
1'	-25.0	1.064	167.2	<b>0.8746</b>	0.0
2'	50.0	13.18	423.4	1.707	<b>1.0</b>
2''	50.0	10.2	430.5	1.746	Superheated
4'	-25.0	1.064	257.1	1.237	0.4158

a)  $COP = (h_1 - h_4) / (h_2 - h_1) = 2.1174$

b) Work input to compressor,  $W_c = (h_2 - h_1) = 52.8 \text{ kJ/kg}$

c) Superheat horn area, area  $A_1$ :

$$\text{Area } A_1 = \text{Area under } 2-2' - \text{Area under } 2''-2'$$

$$\text{Area under } 2-2': \quad Tds = (dh - v dP) = dh = h_2 - h_2' \quad (dp = 0)$$

$$\Rightarrow \text{Area under } 2-2' = h_2 - h_2' = 12.8 \text{ kJ/kg}$$

$$\text{Area under } 2''-2' = Tds = T_c (s_2'' - s_2') = 12.6 \text{ kJ/kg}$$

$$\text{Superheat horn area} = \text{Area } A_1 = (12.8 - 12.6) = 0.2 \text{ kJ/kg}$$

d) Throttling loss, Area  $A_2$  (assuming the saturated liquid line to coincide with isobar at condenser pressure):

$$\text{Area } A_2 = \text{Area under } 3-1' - \text{Area under } 4'-1' = (h_3 - h_1') - T_e (s_3 - s_1') \quad (s_3 = s_4')$$

$$\text{Throttling area} = (271.6 - 167.2) - 248.15(1.237 - 0.8746) = 14.47 \text{ kJ/kg}$$

**Alternatively:**

$$\text{Throttling area} = \text{Area under } 4-4' = T_e (s_4 - s_4') = 248.15(1.295 - 1.237) = 14.4 \text{ kJ/kg}$$

**Check:**

$$W_{\text{SSS}} = W_{\text{Carnot}} + \text{Area } A_1 + \text{Area } A_2$$

$$W_{\text{Carnot}} = (T_c - T_e)(s_1 - s_4') = 75(1.746 - 1.237) = 38.2 \text{ kJ/kg}$$

$$W_{\text{SSS}} = 38.2 + 14.4 + 0.2 = 52.8 \text{ kJ/kg}$$

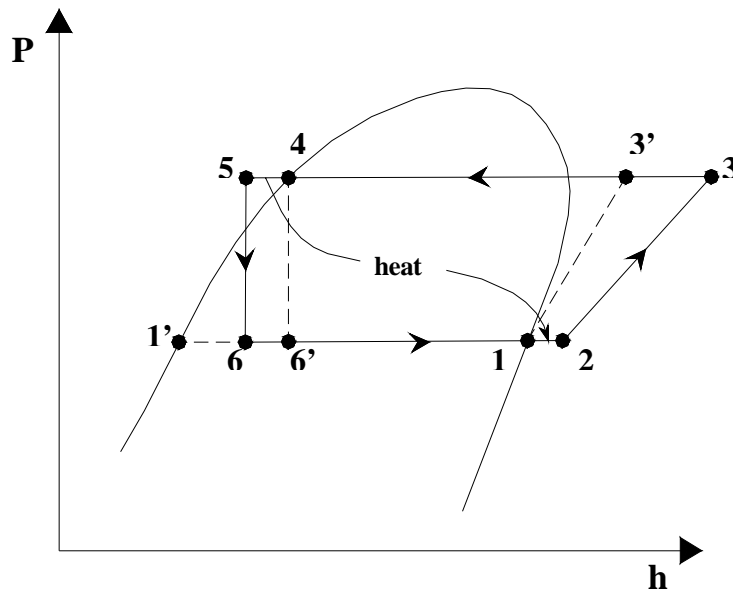
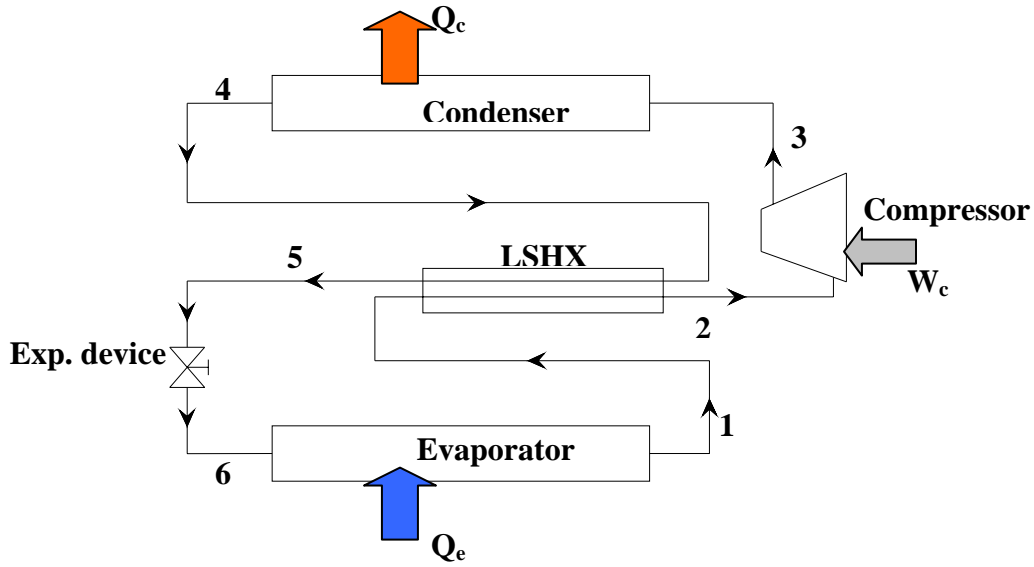
**10.** In a R22 based refrigeration system, a liquid-to-suction heat exchanger (LSHX) with an effectiveness of 0.65 is used. The evaporating and condensing temperatures are  $7.2^\circ\text{C}$  and  $54.4^\circ\text{C}$  respectively. Assuming the compression process to be isentropic, find:

- Specific refrigeration effect
- Volumic refrigeration effect
- Specific work of compression
- COP of the system
- Temperature of vapour at the exit of the compressor

Comment on the use of LSHX by comparing the performance of the system with a SSS cycle operating between the same evaporator and condensing temperatures.

Ans.:

Given:	Refrigerant	:	R 22
	$T_e$	=	$7.2^\circ\text{C}$
	$T_c$	=	$54.4^\circ\text{C}$
	Effectiveness of LSHX, $\epsilon_X$	=	0.65



Effectiveness of LSHX,  $\epsilon_X = (Q_{act}/Q_{max}) = [(mCp)_{min}\Delta T_{act,min}] / [(mCp)_{min}\Delta T_{max}]$   
 $= (T_2 - T_1) / (T_4 - T_1)$ ;  $C_{p,vapour} < C_{p,liquid}$

$(T_2 - T_1) / (T_4 - T_1) = 0.65 \Rightarrow T_2 = T_1 + 0.65(T_4 - T_1) = 37.88^\circ\text{C}$

From energy balance across LSHX:

$(h_2 - h_1) = (h_4 - h_5) \Rightarrow h_5 = h_4 - (h_2 - h_1)$

From the above data and using refrigerant property values for R 22 at various state points are:

State Point	T (°C)	P (bar)	h (kJ/kg)	s (kJ/kg.K)	v m <sup>3</sup> /kg	Quality
1	7.2	6.254	407.6	1.741	0.03773	1.0
2	<b><u>37.88</u></b>	6.254	430.7	1.819	0.04385	Superheated
3	<b><u>104.9</u></b>	21.46	466.8	1.819	-	Superheated
4	54.4	21.46	269.5	<b>1.227</b>	-	0.0
5	<b><u>37.65</u></b>	21.46	<b><u>246.4</u></b>	<b>1.154</b>	-	Subcooled
6	7.2	6.254	246.4	<b>1.166</b>	-	<b><u>0.1903</u></b>
6'	7.2	6.254	269.5	<b>1.248</b>	-	<b><u>0.3063</u></b>
3'	<b><u>74.23</u></b>	21.46	438.6	<b>1.741</b>	-	Superheated
1'	7.2	6.254	208.5	<b>1.030</b>	-	0.0

**With LSHX:**

- Refrigeration effect =  $(h_1 - h_6) = 161.2 \text{ kJ/kg}$
- Volumic refrigeration effect =  $(h_1 - h_6)/v_2 = 3676.2 \text{ kJ/m}^3$
- Work of compression =  $(h_3 - h_2) = 36.1 \text{ kJ/kg}$
- COP =  $(h_1 - h_6) / (h_3 - h_2) = 4.465$
- Temperature at compressor exit (from  $P_c$  and  $s_3 = s_2$ ) = **104.9°C**

**Without LSHX:**

- Refrigeration effect =  $(h_1 - h_{6'}) = 138.1 \text{ kJ/kg}$
- Volumic refrigeration effect =  $(h_1 - h_{6'})/v_1 = 3660.2 \text{ kJ/m}^3$
- Work of compression =  $(h_{3'} - h_1) = 31.0 \text{ kJ/kg}$
- COP =  $(h_1 - h_{6'}) / (h_{3'} - h_1) = 4.455$
- Temperature at compressor exit (from  $P_c$  and  $s_1 = s_{3'}$ ) = **74.23°C**

<b>Parameter</b>	<b>With LSHX</b>	<b>Without LSHX</b>
<b>Refrigeration effect, kJ/kg</b>	<b>161.2</b>	<b>138.1</b>
<b>Ref. quality at evaporator inlet</b>	<b>0.1903</b>	<b>0.3063</b>
<b>Vol. Refrigeration effect, kJ/m<sup>3</sup></b>	<b>3676.2</b>	<b>3660.2</b>
<b>Work of compression, kJ/kg</b>	<b>36.1</b>	<b>31.0</b>
<b>COP</b>	<b>4.465</b>	<b>4.455</b>
<b>Compressor exit temperature, °C</b>	<b>104.9</b>	<b>74.23</b>

**Comments:**

- a) There is no appreciable change in COP with the addition of LSHX
- b) Quality of refrigerant at evaporator inlet is significantly lower with LSHX
- c) Discharge temperature is significantly high with LSHX
- d) For refrigerant R-22, use of LSHX does not improve the performance of the system significantly, however, the evaporator with LSHX performs better due to the lower vapour fraction at its inlet



# Lesson

## 12

# Multi-Stage Vapour Compression Refrigeration Systems

## The objectives of this lesson are to:

1. Discuss limitations of single stage vapour compression refrigeration systems (*Section 12.1*)
2. Classify multi-stage systems (*Section 12.1*)
3. Discuss the concept of flash gas removal using flash tank (*Section 12.2*)
4. Discuss the concept of intercooling in multi-stage vapour compression refrigeration systems (*Section 12.3*)
5. Discuss multi-stage vapour compression refrigeration systems with flash gas removal and intercooling (*Section 12.4*)
6. Discuss the use of flash tank for flash gas removal only (*Section 12.5*)
7. Discuss the use of flash tank for intercooling only (*Section 12.6*)

At the end of the lesson, the student should be able to:

1. Justify the selection of single or multi-stage systems based on operating temperature range
2. Classify multi-stage systems
3. Applying mass and energy balance equations, evaluate the performance of multi-stage vapour compression refrigeration systems with:
  - a) Flash gas removal
  - b) Intercooling
  - c) Flash gas removal using flash tank and intercooling using flash tank and/or external intercooler
  - d) Flash tank for flash gas removal only
  - e) Flash tank for intercooling only, and
  - f) A combination of any of the above

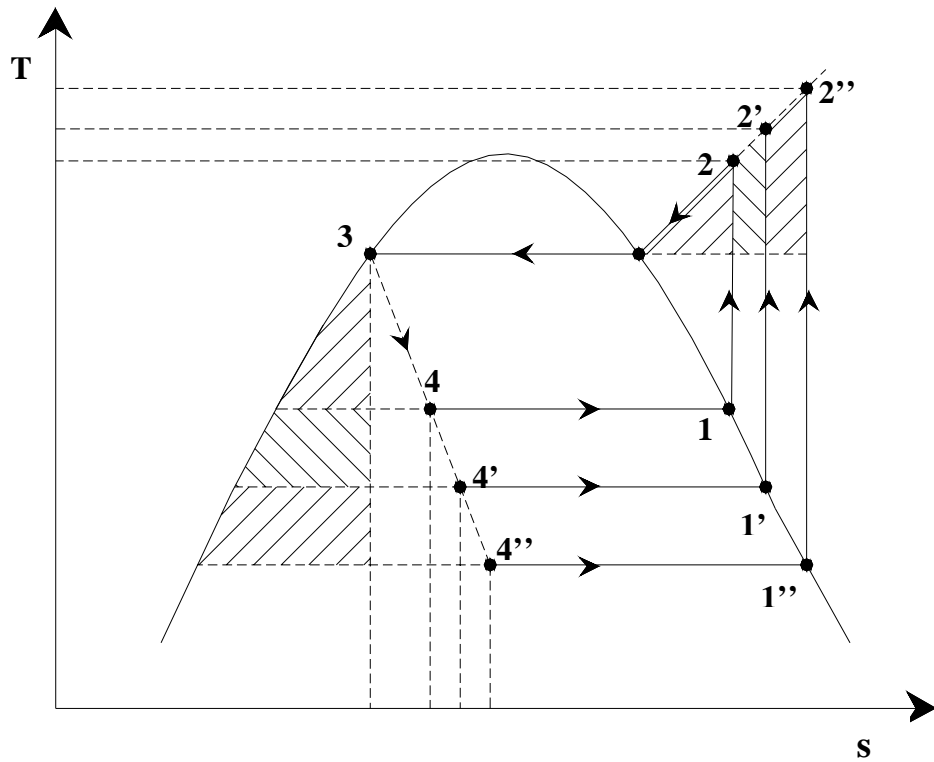
### 12.1. Introduction

A single stage vapour compression refrigeration system has one low side pressure (evaporator pressure) and one high side pressure (condenser pressure). The performance of single stage systems shows that these systems are adequate as long as the temperature difference between evaporator and condenser (*temperature lift*) is small. However, there are many applications where the temperature lift can be quite high. The temperature lift can become large either due to the requirement of very low evaporator temperatures and/or due to the requirement of very high condensing temperatures. For example, in frozen food industries the required evaporator can be as low as  $-40^{\circ}\text{C}$ , while in chemical industries temperatures as low as  $-150^{\circ}\text{C}$  may be required for liquefaction of gases. On the high temperature side the required condensing temperatures can be very high if the refrigeration system is used as a heat pump for heating applications such as process heating, drying etc. However, as the temperature lift increases the single stage systems become inefficient and impractical. For example, Fig. 12.1 shows the effect of decreasing evaporator temperatures on T s and P h diagrams. It can be seen from the T s diagrams that for a given condenser temperature, as evaporator temperature decreases:

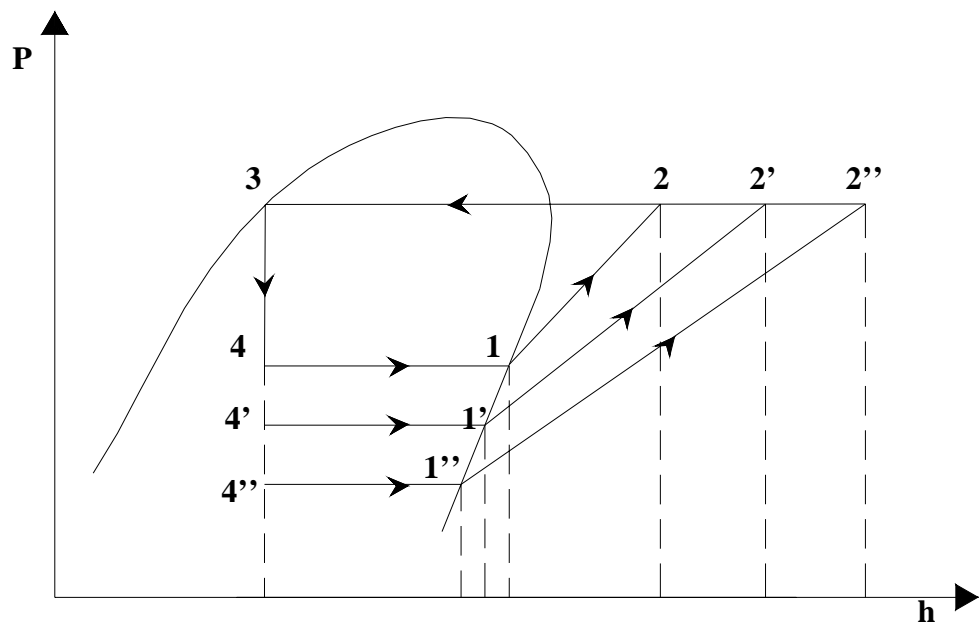
- i. Throttling losses increase
- ii. Superheat losses increase
- iii. Compressor discharge temperature increases
- iv. Quality of the vapour at the inlet to the evaporator increases
- v. Specific volume at the inlet to the compressor increases

As a result of this, the refrigeration effect decreases and work of compression increases as shown in the P h diagram. The volumic refrigeration effect also decreases rapidly as the specific volume increases with decreasing evaporator temperature. Similar effects will occur, though not in the same proportion when the condenser temperature increases for a given evaporator temperature. Due to these drawbacks, single stage systems are not recommended when the evaporator temperature becomes very low and/or when the condenser temperature becomes high. In such cases multi-stage systems are used in practice. Generally, for fluorocarbon and ammonia based refrigeration systems a single stage system is used upto an evaporator temperature of  $-30^{\circ}\text{C}$ . A two-stage system is used upto  $-60^{\circ}\text{C}$  and a three-stage system is used for temperatures below  $-60^{\circ}\text{C}$ .

Apart from high temperature lift applications, multi-stage systems are also used in applications requiring refrigeration at different temperatures. For example, in a dairy plant refrigeration may be required at  $-30^{\circ}\text{C}$  for making ice cream and at  $2^{\circ}\text{C}$  for chilling milk. In such cases it may be advantageous to use a multi-evaporator system with the low temperature evaporator operating at  $-30^{\circ}\text{C}$  and the high temperature evaporator operating at  $2^{\circ}\text{C}$



*Fig.12.1(a): Effect of evaporator temperature on cycle performance (T-s diagram)*



*Fig.12.1(b): Effect of evaporator temperature on cycle performance (P-h diagram)*

A multi-stage system is a refrigeration system with two or more low-side pressures. Multi-stage systems can be classified into:

- a) Multi-compression systems
- b) Multi-evaporator systems
- c) Cascade systems, etc.

Two concepts which are normally integral to multi-pressure systems are, i) flash gas removal, and ii) intercooling. Hence these concepts will be discussed first.

## 12.2. Flash gas removal using flash tank

It is mentioned above that one of the problems with high temperature lift applications is the high quality of vapour at the inlet to the evaporator. This vapour called as *flash gas* develops during the throttling process. The flash gas has to be compressed to condenser pressure, it does not contribute to the refrigeration effect as it is already in the form of vapour, and it increases the pressure drop in the evaporator. It is possible to improve the COP of the system if the flash gas is removed as soon as it is formed and recompressed to condenser pressure. However, continuous removal of flash gas as soon as it is formed and recompressing it immediately is difficult in practice. One way of improving the performance of the system is to remove the flash gas at an intermediate pressure using a *flash tank*. Figure 12.2 shows the schematic of a flash tank and Fig.12.3 shows the expansion process employing flash tank. A flash tank is a pressure vessel, wherein the refrigerant liquid and vapour are separated at an intermediate pressure. The refrigerant from condenser is first expanded to an intermediate pressure corresponding to the pressure of flash tank,  $P_i$  using a low side float valve (process 6-7). The float valve also maintains a constant liquid level in the flash tank. In the flash tank, the refrigerant liquid and vapour are separated. The saturated liquid at point 8 is fed to the evaporator after throttling it to the required evaporator pressure,  $P_e$  (point 9) using an expansion valve. Depending upon the type of the system, the saturated vapour in the flash tank (point 3) is either compressed to the condenser pressure or throttled to the evaporator pressure. In the absence of flash tank, the refrigerant condition at the inlet to the evaporator would have been point 9', which has a considerably high vapour quality compared to point 9. As mentioned, the refrigerant liquid and vapour must get separated in the flash tank. This is possible when the upward velocity of the refrigerant vapour in the flash tank is low enough ( $< 1$  m/s) for the refrigerant liquid droplets to fall back into the flash tank due to gravity. Thus the surface area of liquid in the flash tank can be obtained from the volumetric flow rate of refrigerant vapour and the required low refrigerant velocity.

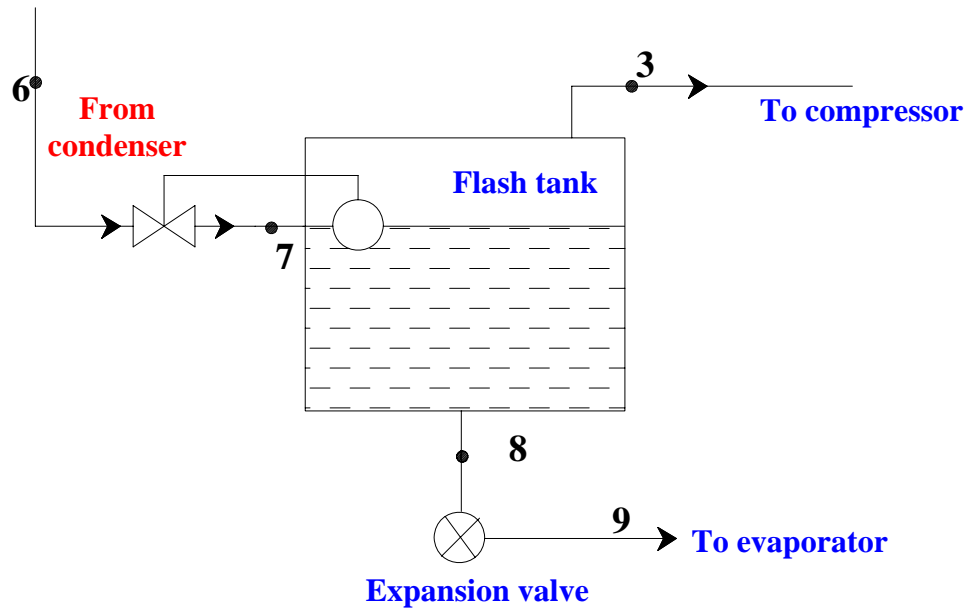


Fig.12.2(a): Working principle of a flash tank

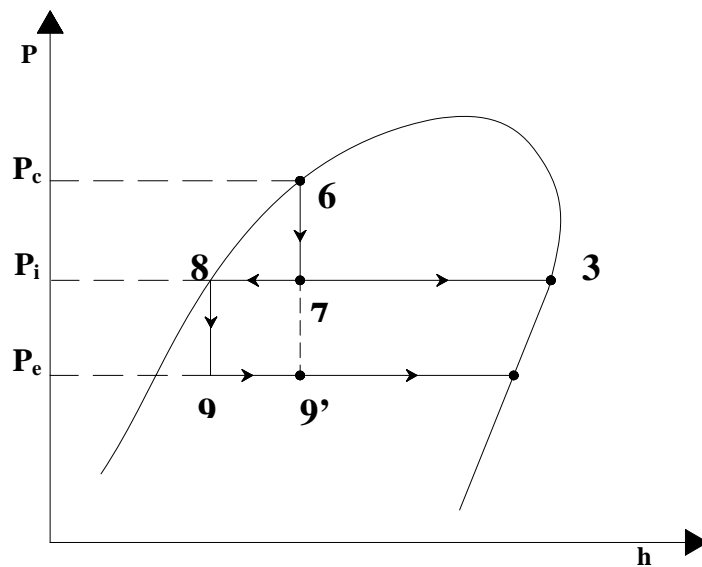


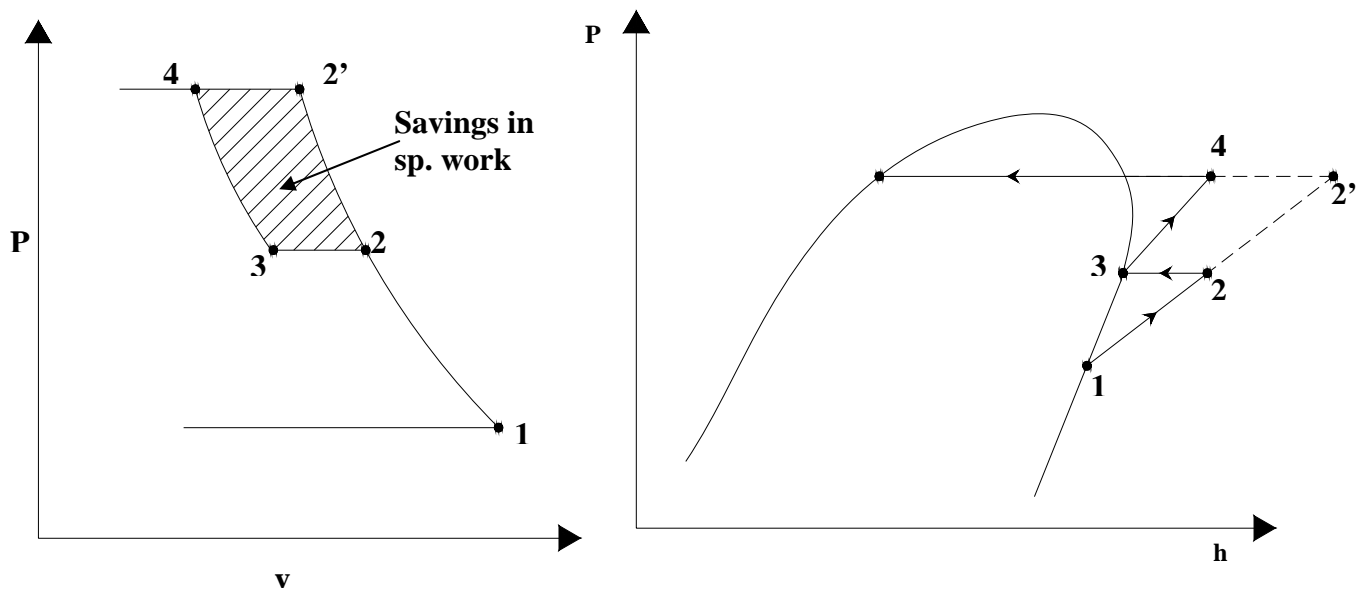
Fig.12.3: Expansion process using a flash tank on P-h diagram

### 12.3. Intercooling in multi-stage compression

The specific work input,  $w$  in reversible, polytropic compression of refrigerant vapour is given by:

$$w = -\int_1^2 v \cdot dP = \left( \frac{n}{n-1} \right) P_1 v_1 \left[ 1 - \left( \frac{P_2}{P_1} \right)^{(n-1)/n} \right] \quad (12.1)$$

where  $P_1$  and  $P_2$  are the inlet and exit pressures of the compressor,  $v_1$  is the specific volume of the refrigerant vapour at the inlet to the compressor and  $n$  is the polytropic exponent. From the above expression, it can be seen that specific work input reduces as specific volume,  $v_1$  is reduced. At a given pressure, the specific volume can be reduced by reducing the temperature. This is the principle behind intercooling in multi-stage compression. Figures 12.4 (a) and (b) show the process of intercooling in two-stage compression on Pressure-specific volume (P-v) and P-h diagrams.

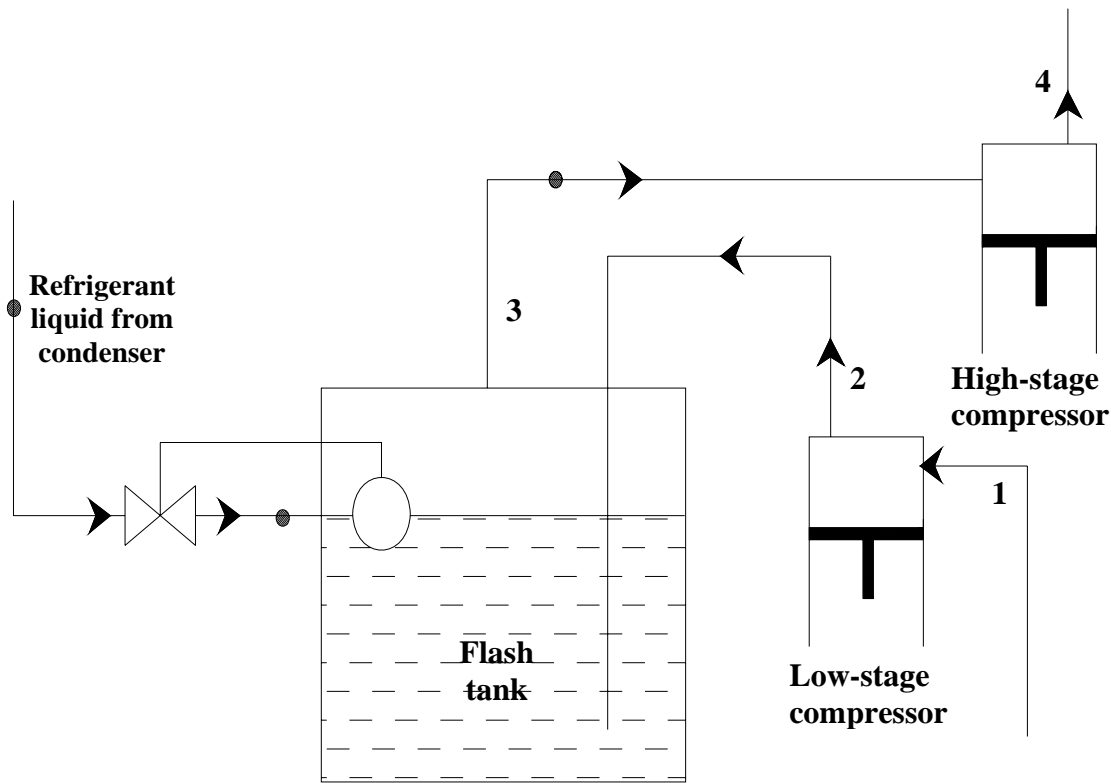


*Fig.12.4(a) & (b): Intercooling in two-stage compression*

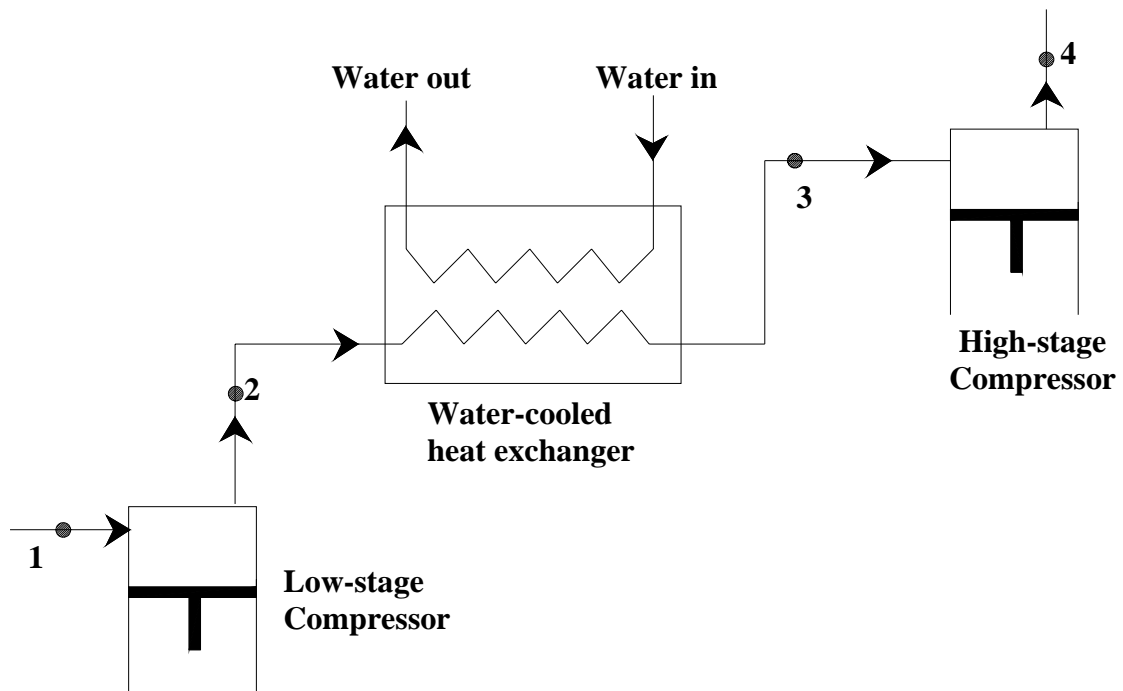
As shown in the figures, in stead of compressing the vapour in a single stage from state 1 to state 2', if the refrigerant is compressed from state 1 to an intermediate pressure, state 2, intercooled from 2 to 3 and then compressed to the required pressure (state 4), reduction in work input results. If the processes are reversible, then the savings in specific work is given by the shaded area 2-3-4-2' on P-v diagram. The savings in work input can also be verified from the P-h diagram. On P-h diagram, lines 1-2-2' and 3-4 represent isentropes. Since the slope of isentropes on P-h diagram reduces (lines become flatter) as they move away from the saturated vapour line,

$$(h_4-h_3) < (h_{2'}-h_2) \Rightarrow (h_2-h_1)+(h_4-h_3) < (h_{2'}-h_1) \quad (12.2)$$

Intercooling of the vapour may be achieved by using either a water-cooled heat exchanger or by the refrigerant in the flash tank. Figures 12.5(a) and (b) show these two systems. Intercooling may not be always possible using water-cooled heat exchangers as it depends on the availability of sufficiently cold water to which the refrigerant from low stage compressor can reject heat. Moreover, with water cooling the refrigerant at the inlet to the high stage compressor may not be saturated. Water cooling is commonly used in air compressors. Intercooling not only reduces the work input but also reduces the compressor discharge temperature leading to better lubrication and longer compressor life.



*Fig.12.5(a): Intercooling using liquid refrigerant in flash tank*



*Fig.12.5(b): Intercooling using external water cooled heat exchanger*

Intercooling using liquid refrigerant from condenser in the flash tank may or may not reduce the power input to the system, as it depends upon the nature of the refrigerant. This is due to the fact that the heat rejected by the refrigerant during intercooling generates additional vapour in the flash tank, which has to be compressed by the high stage compressor. Thus the mass flow rate of refrigerant through the high stage compressor will be more than that of the low stage compressor. Whether total power input to the system decreases or not depends on whether the increased power consumption due to higher mass flow rate is



compensated by reduction in specific work of compression or not. For ammonia, the power input usually decreases with intercooling by liquid refrigerant, however, for refrigerants such as R12, R22, the power input marginally increases. Thus intercooling using liquid refrigerant is not effective for R12 and R22. However, as mentioned one benefit of intercooling is the reduction in compressor discharge temperature, which leads to better compressor lubrication and its longer life.

It is also possible to intercool the refrigerant vapour by a combination of water-cooled heat exchanger and the refrigerant liquid in the flash tank. As a result of using both water-cooling and flash-tank, the amount of refrigerant vapour handled by the high-stage compressor reduces leading to lower power consumption. However, the possibility of this again depends on the availability of cooling water at required temperature.

One of the design issues in multi-stage compression is the selection of suitable intermediate pressure. For air compressors with intercooling to the initial temperature, the theoretical work input to the system will be minimum when the pressure ratios are equal for all stages. This also results in equal compressor discharge temperatures for all compressors. Thus for a two-stage air compressor with intercooling, the optimum intermediate pressure,  $P_{i,opt}$  is:

$$P_{i,opt} = \sqrt{P_{low} \cdot P_{high}} \quad (12.3)$$

where  $P_{low}$  and  $P_{high}$  are the inlet pressure to the low-stage compressor and exit pressure from the high-stage compressor, respectively. The above relation is found to hold good for ideal gases. For refrigerants, correction factors to the above equation are suggested, for example one such relation for refrigerants is given by:

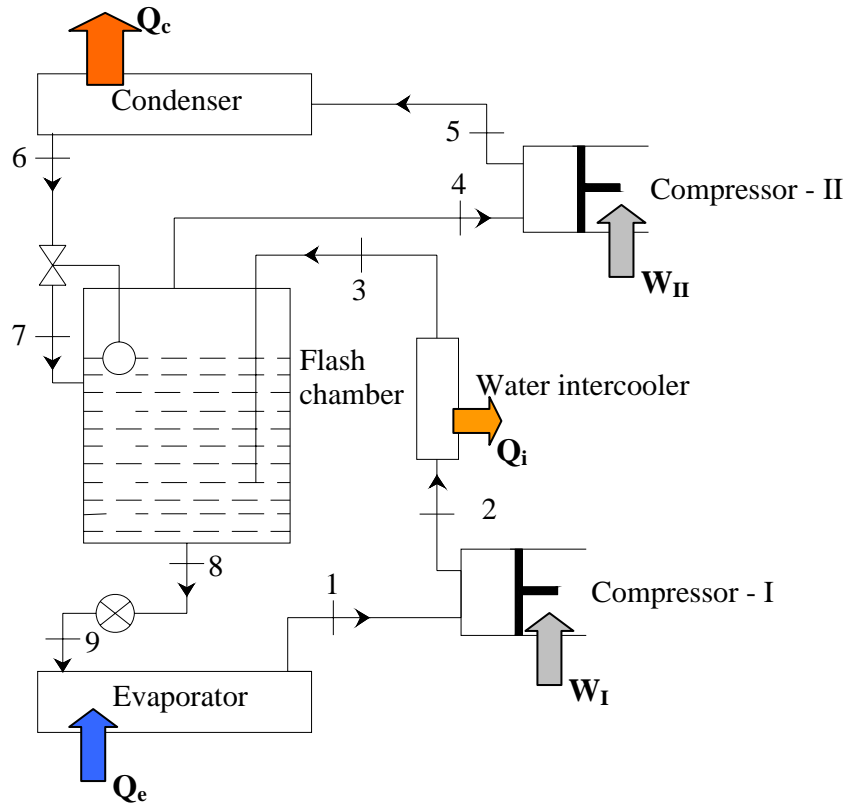
$$P_{i,opt} = \sqrt{P_e \cdot P_c \frac{T_c}{T_e}} \quad (12.4)$$

where  $P_e$  and  $P_c$  are the evaporator and condenser pressures, and  $T_c$  and  $T_e$  are condenser and evaporator temperatures (in K).

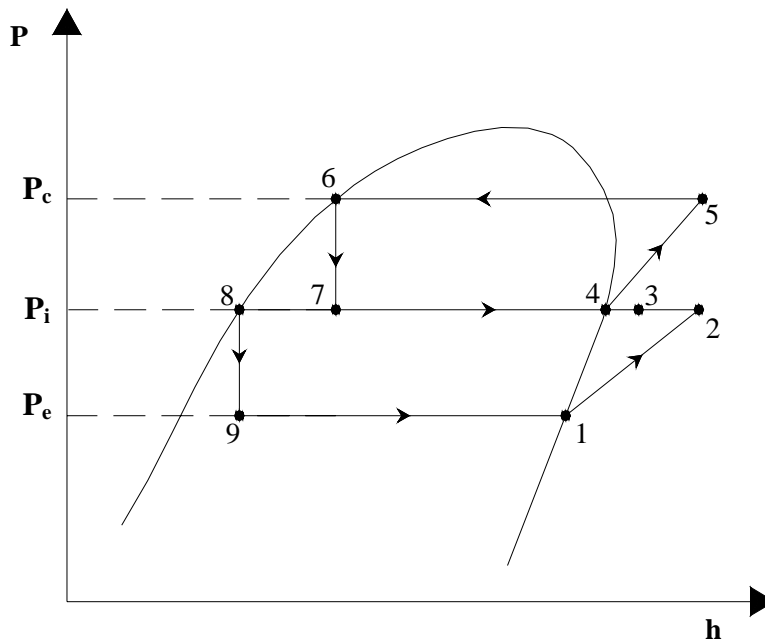
Several combinations of multi-stage systems are used in practice. Some of them are discussed below.

## 12.4. Multi-stage system with flash gas removal and intercooling

Figures 12.6(a) and (b) show a two-stage vapour compression refrigeration system with flash gas removal using a flash tank, and intercooling of refrigerant vapour by a water-cooled heat exchanger and flash tank. The superheated vapour from the water cooled heat exchanger bubbles through the refrigerant liquid in the flash tank. It is assumed that in this process the superheated refrigerant vapour gets completely de-superheated and emerges out as a saturated vapour at state 4. However, in practice complete de-superheating may not be possible. As mentioned the use of combination of water cooling with flash tank for intercooling reduces the vapour generated in the flash tank. The performance of this system can be obtained easily by applying mass and energy balance equations to the individual components. It is assumed that the flash tank is perfectly insulated and the potential and kinetic energy changes of refrigerant across each component are negligible.



**Fig.126(a):** Two-stage vapour compression refrigeration system with flash gas removal using a flash tank and intercooling



**Fig.126(b):** Two-stage vapour compression refrigeration system with flash gas removal using a flash tank and intercooling – P-h diagram

From mass and energy balance of the flash tank:

$$\dot{m}_7 + \dot{m}_3 = \dot{m}_8 + \dot{m}_4 \quad (12.5)$$

$$\dot{m}_7 h_7 + \dot{m}_3 h_3 = \dot{m}_8 h_8 + \dot{m}_4 h_4 \quad (12.6)$$

From mass and energy balance across expansion valve,

$$\dot{m}_8 = \dot{m}_9 \quad (12.7)$$

$$h_8 = h_9 \quad (12.8)$$

From mass and energy balance across evaporator:

$$\dot{m}_9 = \dot{m}_1 \quad (12.9)$$

$$Q_e = \dot{m}_1 (h_1 - h_9) \quad (12.10)$$

From mass and energy balance across low-stage compressor, Compressor-I:

$$\dot{m}_9 = \dot{m}_1 = \dot{m}_I \quad (12.11)$$

$$W_I = \dot{m}_I (h_2 - h_1) \quad (12.12)$$

where  $\dot{m}_I$  is the mass flow rate of refrigerant through Compressor-I.

From mass and energy balance across water-cooled intercooler:

$$\dot{m}_2 = \dot{m}_3 = \dot{m}_I \quad (12.13)$$

$$Q_I = \dot{m}_I (h_2 - h_3) \quad (12.14)$$

where  $Q_I$  is the heat transferred by the refrigerant to the cooling water in the intercooler.

From mass and energy balance across high-stage compressor, Compressor-II:

$$\dot{m}_4 = \dot{m}_5 = \dot{m}_{II} \quad (12.15)$$

$$W_{II} = \dot{m}_{II} (h_5 - h_4) \quad (12.16)$$

where  $\dot{m}_{II}$  is the mass flow rate of refrigerant through Compressor-II.

Finally, from mass and energy balance across condenser:

$$\dot{m}_5 = \dot{m}_6 = \dot{m}_{II} \quad (12.17)$$

$$Q_c = \dot{m}_{II} (h_5 - h_6) \quad (12.18)$$

Finally, from mass and energy balance across the float valve:

$$\dot{m}_6 = \dot{m}_7 = \dot{m}_{II} \quad (12.19)$$

$$h_6 = h_7 \quad (12.20)$$

From the above set of equations, it can be easily shown that for the flash tank:

$$\dot{m}_7 = \dot{m}_4 = \dot{m}_{II} \quad (12.21)$$

$$\dot{m}_3 = \dot{m}_8 = \dot{m}_I \quad (12.22)$$

$$\dot{m}_{II} = \dot{m}_I \left[ \frac{h_3 - h_8}{h_4 - h_7} \right] \quad (12.23)$$

It can be seen from the above expression that the refrigerant flow through the high-stage compression  $m_{II}$  can be reduced by reducing the enthalpy of refrigerant vapour entering into the flash tank,  $h_3$  from the water-cooled intercooler.

The amount of additional vapour generated due to de-superheating of the refrigerant vapour from the water-cooled intercooler is given by:

$$m_{gen} = m_I \left[ \frac{h_3 - h_4}{h_4 - h_8} \right] \quad (12.24)$$

Thus the vapour generated  $m_{gen}$  will be zero, if the refrigerant vapour is completely de-superheated in the water-cooled intercooler itself. However, this may not be possible in practice.

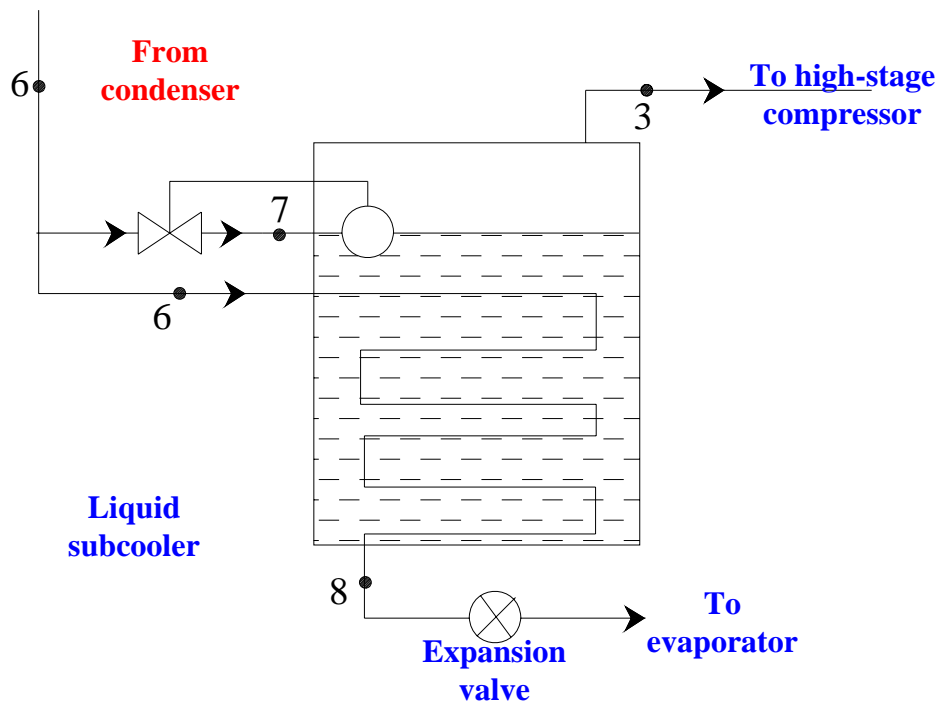
For the above system, the COP is given by:

$$COP = \frac{Q_e}{W_I + W_{II}} = \frac{m_I(h_1 - h_9)}{m_I(h_2 - h_1) + m_{II}(h_5 - h_4)} \quad (12.25)$$

The above system offers several advantages,

- a) Quality of refrigerant entering the evaporator reduces thus giving rise to higher refrigerating effect, lower pressure drop and better heat transfer in the evaporator
- b) Throttling losses are reduced as vapour generated during throttling from  $P_c$  to  $P_i$  is separated in the flash tank and recompressed by Compressor-II.
- c) Volumetric efficiency of compressors will be high due to reduced pressure ratios
- d) Compressor discharge temperature is reduced considerably.

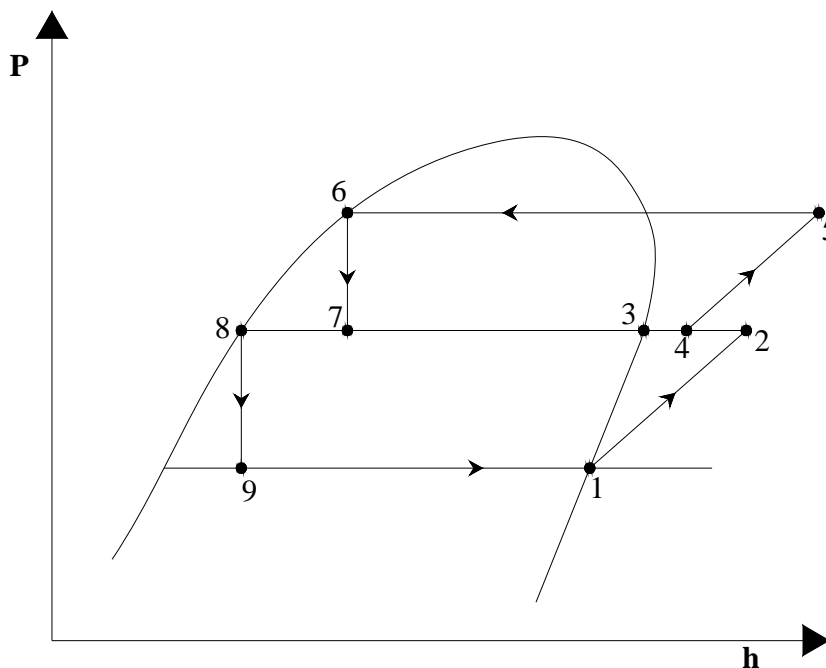
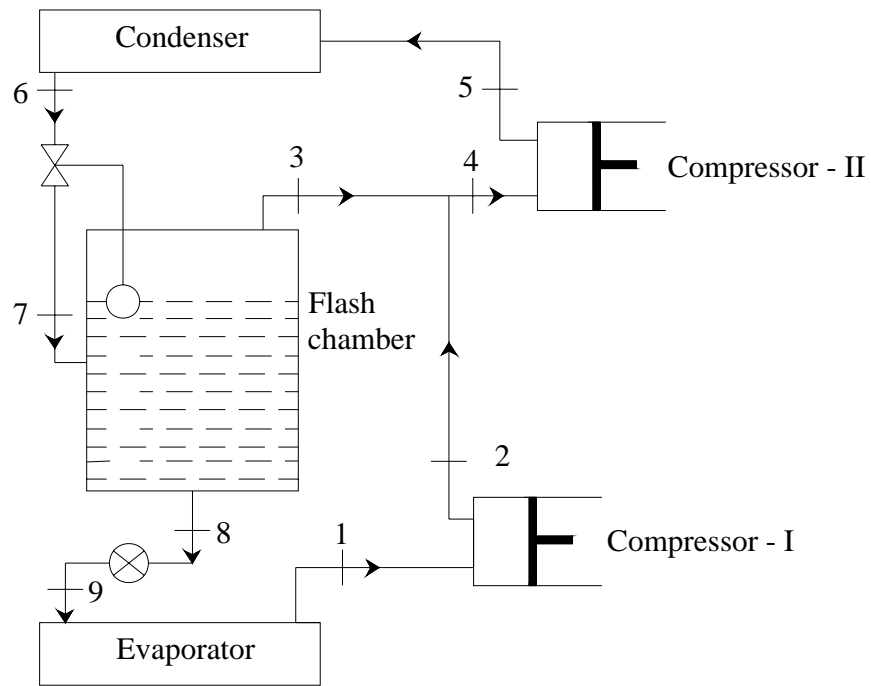
However, one disadvantage of the above system is that since refrigerant liquid in the flash tank is saturated, there is a possibility of liquid flashing ahead of the expansion valve due to pressure drop or heat transfer in the pipelines connecting the flash tank to the expansion device. Sometimes this problem is tackled by using a system with a *liquid subcooler*. As shown in Fig.12.7, in a liquid subcooler the refrigerant liquid from the condenser is subcooled by exchanging heat with the refrigerant liquid in the flash tank. As a result, a small amount of refrigerant vapour is generated in the flash tank, which needs to be compressed in the high-stage compressor. Compared to the earlier system, the temperature of refrigerant liquid from the subcooler will be higher than the saturated refrigerant temperature in the flash tank due to indirect contact heat transfer. However, since the refrigerant at the inlet to the expansion valve is at high pressure and is subcooled, there is less chance of flashing of liquid ahead of expansion valve.



*Fig.12.7: Refrigeration system with liquid subcooler*

## 12.5. Use of flash tank for flash gas removal

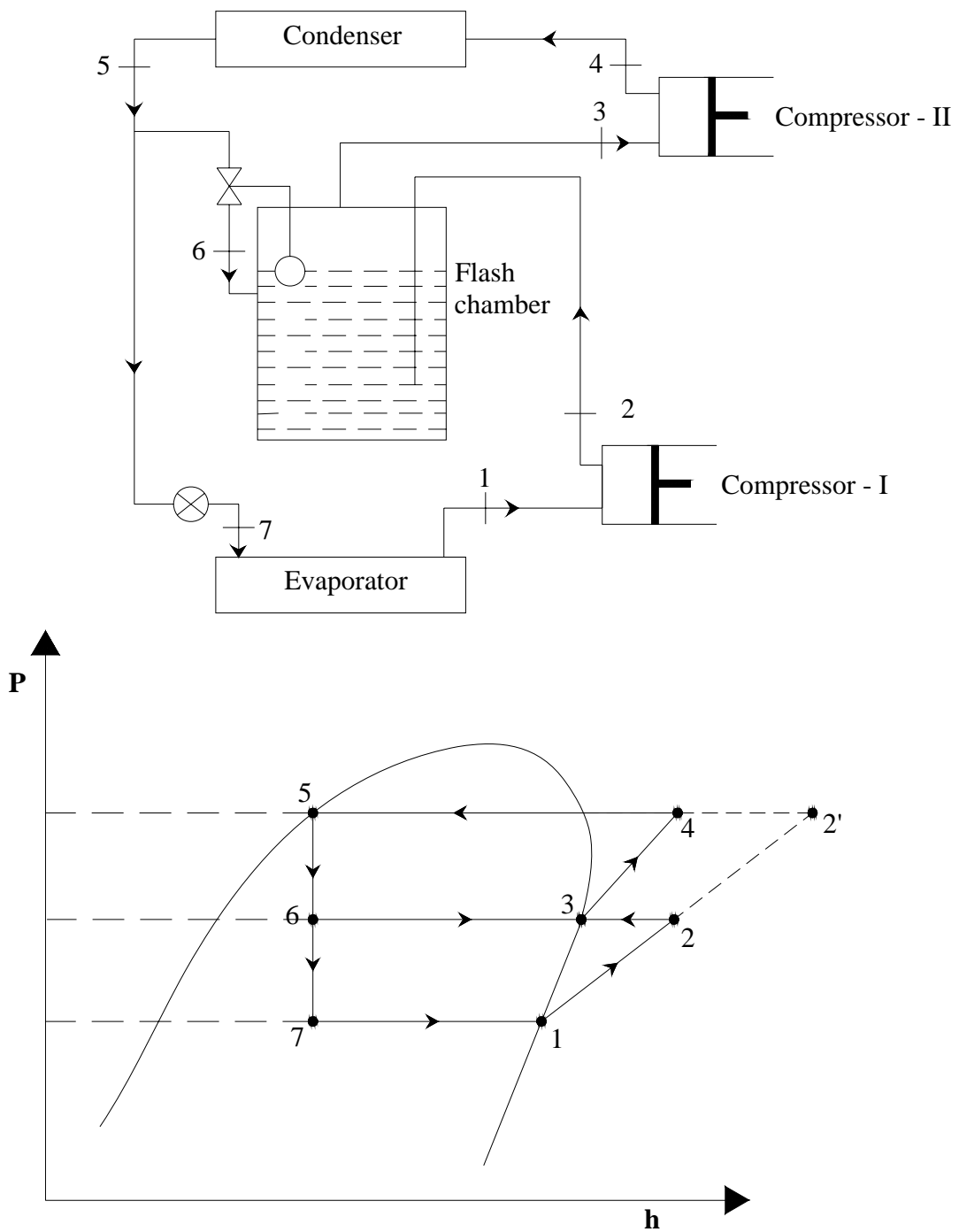
Intercooling of refrigerant vapour using water-cooled heat exchangers is possible in ammonia systems due to high discharge temperature of ammonia. However, this is generally not possible in systems using refrigerants such as R 12 or R 134a due to their low discharge temperatures. In these systems, instead of passing the refrigerant vapour from the low-stage compressor through the flash tank, vapour from the flash tank is mixed with the vapour coming from the low-stage compressor. As a result, the inlet condition to the high-stage compressor will be slightly superheated. A two-stage compression system with flash tank for flash gas removal for refrigerants such as R 134a is shown in Fig. 12.8 (a). Figure 12.8 (b) shows the corresponding P-h diagram.



**Fig.12.8:** A two-stage compression system with flash tank for flash gas removal only  
 (a) System schematic; (b) Cycle on P-h diagram

## 12.6. Use of flash tank for intercooling only

Sometimes the flash tank is used for intercooling of the refrigerant vapour between the low and high-stage compressors. It is not used for flash gas removal. Figures 12.9 (a) and (b) show the system schematic and P-h diagram of a two-stage compression system where the flash tank is used for intercooling only.



**Fig.12.9:** A two-stage compression system with the flash tank used for intercooling only  
 (a) System schematic (b) Cycle on P-h diagram

## Questions:

1. When the temperature lift of a single stage vapour compression refrigeration system increases:

- a) Refrigeration effect increases
- b) Work of compression increases
- c) Compressor discharge temperature decreases
- d) Volumetric efficiency of compressor increases

**Ans.: b)**

2. Multi-stage vapour compression refrigeration systems are used when:

- a) Required temperature lift increases
- b) Required temperature lift decreases
- c) Refrigeration is required at different temperatures
- d) Required refrigeration capacity is large

**Ans.: a) and c)**

3. Using a flash tank:

- a) Flash gas formed during expansion can be removed at an intermediate pressure
- b) Quality of refrigerant at the evaporator inlet can be increased
- c) Temperature of refrigerant vapour at the inlet to higher stage compressor can be reduced
- d) Pressure drop in evaporator can be reduced

**Ans.: a) , c) and d)**

4. Using intercooling in multi-stage compression systems:

- a) Refrigeration effect can be increased
- b) Work of compression in higher stage compressor can be reduced
- c) Maximum cycle temperature can be increased
- d) All of the above

**Ans.: b)**

5. External intercooling of refrigerant vapour:

- a) Is feasible for ammonia based systems
- b) Commonly used in air compressors
- c) Commonly used for halocarbon refrigerants
- d) Depends on availability of cold external water

**Ans.: a) and b)**



6. Assuming the refrigerant vapour to behave as an ideal gas and with perfect intercooling, the optimum intermediate pressure of a refrigeration system that operates between 4 bar and 16 bar is equal to:

- a) 10 bar
- b) 8 bar
- c) 6 bar
- d) 12 bar

**Ans.: b)**

7. Refrigeration system with liquid subcooler is used to:

- a) Prevent the entry of liquid into compressor
- b) Prevent flashing of refrigerant liquid ahead of low stage expansion device
- c) Reduce work of compression
- d) All of the above

**Ans. b)**

8. In two-stage compression system with flash gas removal:

- a) Refrigerant mass flow rates in both low and high stage compressors are equal
- b) Refrigerant mass flow rates in high stage compressors is greater than that in low stage compressor
- c) Refrigerant mass flow rates in high stage compressors is smaller than that in low stage compressor
- d) Mass flow rates in low and high stage compressors are equal if the pressure ratios are equal

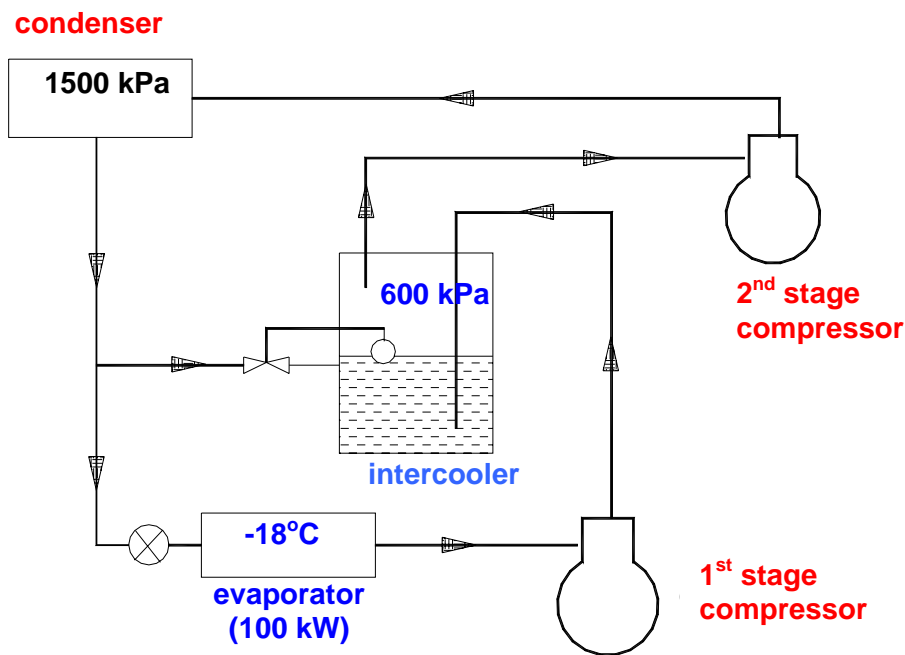
**Ans.: b)**

9. Use of flash tank for intercooling:

- a) Always improves system COP
- b) COP increases or decreases depends on the refrigerant used
- c) Maximum compressor discharge temperature always decreases
- d) Power input to the system always decreases

**Ans.: b) and c)**

10. The required refrigeration capacity of a vapour compression refrigeration system (with R-22 as refrigerant) is 100 kW at  $-30^{\circ}\text{C}$  evaporator temperature. Initially the system was single-stage with a single compressor compressing the refrigerant vapour from evaporator to a condenser operating at 1500 kPa pressure. Later the system was modified to a two-stage system operating on the cycle shown below. At the intermediate pressure of 600 kPa there is intercooling but no removal of flash gas. Find a) Power requirement of the original single-stage system; b) Total power requirement of the two compressors in the revised two-stage system. Assume that the state of refrigerant at the exit of evaporator, condenser and intercooler is saturated, and the compression processes are isentropic.

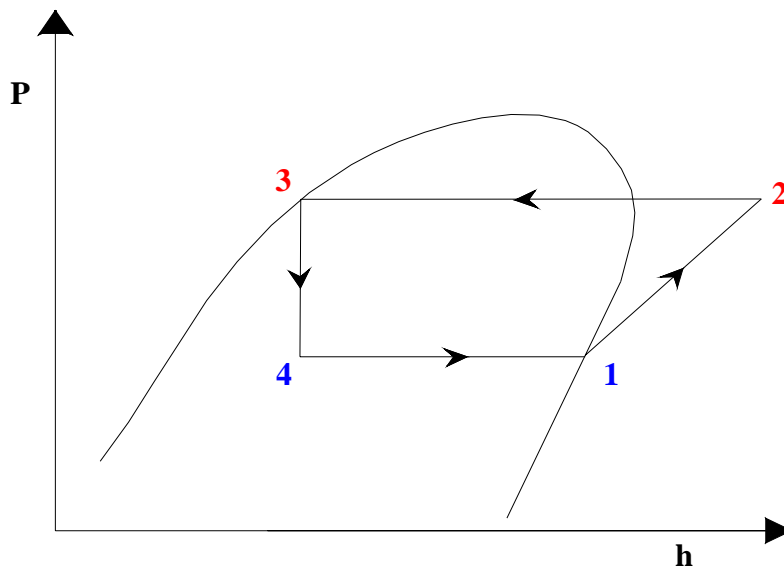


Ans.:

From refrigerant property data, the following values are obtained for R 22:

Point	Temp., $^{\circ}\text{C}$	Pressure, kPa	Dryness fraction	Density, $\text{kg/m}^3$	Enthalpy, $\text{kJ/kg}$	Entropy, $\text{kJ/kg}\cdot\text{K}$
1	-30	163.9	1.0	7.379	392.7	1.802
3	39.1	1500	0.0	-	248.4	-
2	<b>76.93</b>	1500	-	-	449.9	1.802
2'''	<b>53.55</b>	1500	-	-	429.6	1.742
2''	5.86	600	1.0	-	407.2	1.742
2'	<b>28.94</b>	600	-	-	424.4	1.802

**a) Single stage system:**



Required refrigerant mass flow rate,  $m_r$  is given by:

$$m_r = Q_e / (h_1 - h_4) = 100 / (392.7 - 248.4) = \mathbf{0.693 \text{ kg/s}}$$

Power input to compressor,  $W_c$  is given by:

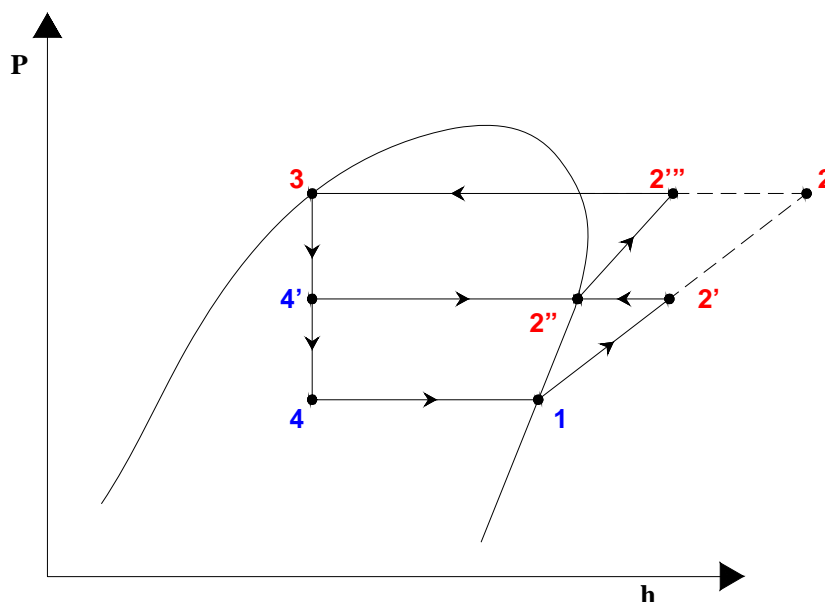
$$W_c = m_r (h_2 - h_1) = 0.693 (449.9 - 392.7) = \mathbf{39.64 \text{ kW}}$$

COP of the single stage system is given by:

$$\text{COP} = Q_e / W_c = 100 / 39.64 = \mathbf{2.523}$$

Compressor discharge temperature =  $\mathbf{76.93 \text{ }^\circ\text{C}}$  (from property data)

**Two-stage system with flash tank for intercooling only:**



Required refrigerant mass flow rate through evaporator and 1<sup>st</sup> stage compressor ( $m_{r,1}$ ) is same as that of single stage system, i.e.,

$$m_{r,1} = \mathbf{0.693 \text{ kg/s}}$$

Power input to 1<sup>st</sup> stage compressor,  $W_{c,1}$  is given by:

$$W_{c,1} = m_{r,1}(h_{2'} - h_1) = 0.693(424.4 - 392.7) = \mathbf{21.97 \text{ kW}}$$

The mass flow rate of refrigerant vapour through 2<sup>nd</sup> stage compressor ( $m_{r,2}$ ) is obtained from energy balance across intercooler:

$$m_{r,2}.h_{2''} = m_{r,1}.h_{2'} + (m_{r,2} - m_{r,1}).h_{4'}$$

Substituting the values of enthalpy and mass flow rate through 1<sup>st</sup> stage compressor:

$$m_{r,2} = \mathbf{0.768 \text{ kg/s}}$$

Power input to 2<sup>nd</sup> stage compressor,  $W_{c,2}$  is given by:

$$W_{c,2} = m_{r,2}(h_{2'''} - h_{2''}) = 0.768(429.6 - 407.2) = \mathbf{17.2 \text{ kW}}$$

Therefore, total power input,  $W_c$  is given by:

$$W_c = W_{c,1} + W_{c,2} = 21.97 + 17.2 = \mathbf{39.17 \text{ kW}}$$

COP of the two-stage system is given by:

$$\text{COP} = Q_e / (W_{c,1} + W_{c,2}) = 100 / 39.17 = \mathbf{2.553}$$

From property data, the discharge temperatures at the exit of 1<sup>st</sup> and 2<sup>nd</sup> stage compressors are given, respectively by:

$$\begin{aligned} T_{2'} &= \mathbf{28.94^\circ\text{C}} \\ T_{2'''} &= \mathbf{53.55^\circ\text{C}} \end{aligned}$$

### Comments:

It is observed from the above example that for the given input data, though the use of a two-stage system with intercooling in place of a single stage system does not increase the COP significantly ( $\approx 1.2 \%$ ), there is a significant reduction in the maximum compressor discharge temperature ( $\approx 24^\circ\text{C}$ ). The results would be different if the operating conditions and/or the refrigerant used is different.

# Lesson

13

# Multi-Evaporator And Cascade Systems

## The objectives of this lesson are to:

1. Discuss the advantages and applications of multi-evaporator systems compared to single stage systems (*Section 13.1*)
2. Describe multi-evaporator systems using single compressor and a pressure reducing valve with:
  - a) Individual expansion valves (*Section 13.2.1*)
  - b) Multiple expansion valves (*Section 13.2.2*)
3. Describe multi-evaporator systems with multi-compression, intercooling and flash gas removal (*Section 13.3*)
4. Describe multi-evaporator systems with individual compressors and multiple expansion valves (*Section 13.4*)
5. Discuss limitations of multi-stage systems (*Section 13.5*)
6. Describe briefly cascade systems (*Section 13.6*)
7. Describe briefly the working principle of auto-cascade cycle (*Section 13.7*)

At the end of the lecture, the student should be able to:

1. Explain the need for multi-evaporator systems
2. Evaluate the performance of:
  - a) Multi-evaporator systems with single compressor and individual expansion valves
  - b) Multi-evaporator systems with single compressor and multiple expansion valves
3. Evaluate the performance of multi-evaporator systems with multi-compression, intercooling and flash gas removal
4. Evaluate the performance of multi-evaporator systems with individual compressors and multiple or individual expansion valves
5. Evaluate the performance of cascade systems
6. Describe the working principle of auto-cascade systems

### 13.1. Introduction

As mentioned in Chapter 12, there are many applications where refrigeration is required at different temperatures. For example, in a typical food processing plant, cold air may be required at  $-30^{\circ}\text{C}$  for freezing and at  $+7^{\circ}\text{C}$  for cooling of food products or space cooling. One simple alternative is to use different refrigeration systems to cater to these different loads. However, this may not be economically viable due to the high total initial cost. Another alternative is to use a single refrigeration system with one compressor and two evaporators both operating at  $-30^{\circ}\text{C}$ . The schematic of such a system and corresponding operating cycle on P-h diagram are shown in Figs. 13.1(a) and (b). As shown in the figure the system consists of a single compressor and a single condenser but two evaporators. Both evaporators-I and II operate at same evaporator temperature ( $-30^{\circ}\text{C}$ ) one evaporator (say Evaporator-I) caters to freezing while the other (Evaporator-II) caters to product cooling/space conditioning at  $7^{\circ}\text{C}$ . It can be seen that operating the evaporator at  $-30^{\circ}\text{C}$  when refrigeration is required at  $+7^{\circ}\text{C}$  is thermodynamically inefficient as the system irreversibilities increase with increasing temperature difference for heat transfer.

The COP of this simple system is given by:

$$\text{COP} = \frac{Q_{e,I} + Q_{e,II}}{W_c} = \frac{(h_1 - h_4)}{(h_2 - h_1)} \quad (13.1)$$

In addition to this there will also be other difficulties such as: evaporator catering to space cooling (7°C) may collect frost leading to blockage of air-flow passages, if a liquid is to chilled then it may freeze on the evaporator and the moisture content of air may become too low leading to water losses in the food products. In such cases multi-stage systems with multiple evaporators can be used. Several multi-evaporator combinations are possible in practice. Some of the most common ones are discussed below.

## 13.2. Individual evaporators and a single compressor with a pressure-reducing valve

### 13.2.1. Individual expansion valves:

Figures 13.2 (a) and (b) show system schematic and P-h diagram of a multi-evaporator system that uses two evaporators at two different temperatures and a single compressor. This system also uses individual expansion valves and a pressure regulating valve (PRV) for reducing the pressure from that corresponding to the high temperature evaporator to the compressor suction pressure. The PRV also maintains the required pressure in high temperature evaporator (Evaporator-II). Compared to the earlier system, this system offers the advantage of higher refrigeration effect at the high temperature evaporator [(h<sub>6</sub>-h<sub>4</sub>) against (h<sub>7</sub>-h<sub>5</sub>)]. However, this advantage is counterbalanced by higher specific work input due to the operation of compressor in

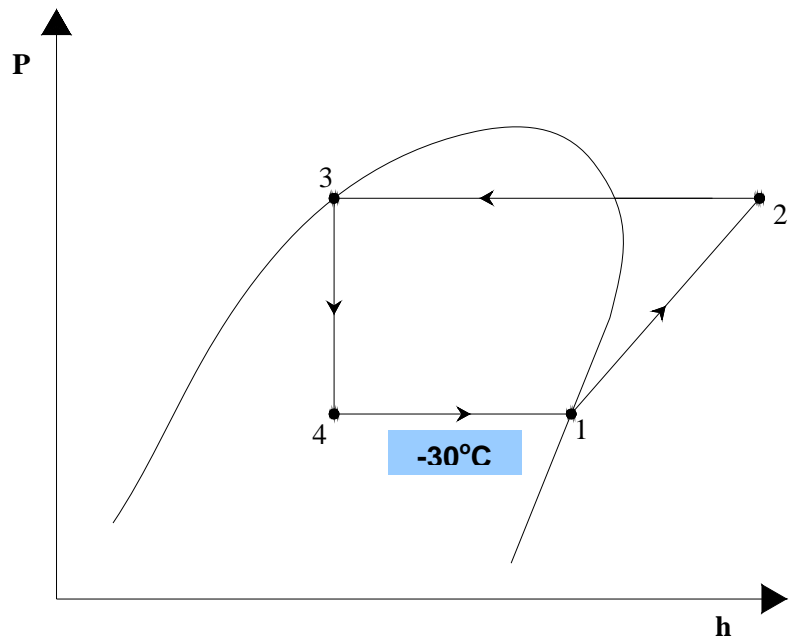
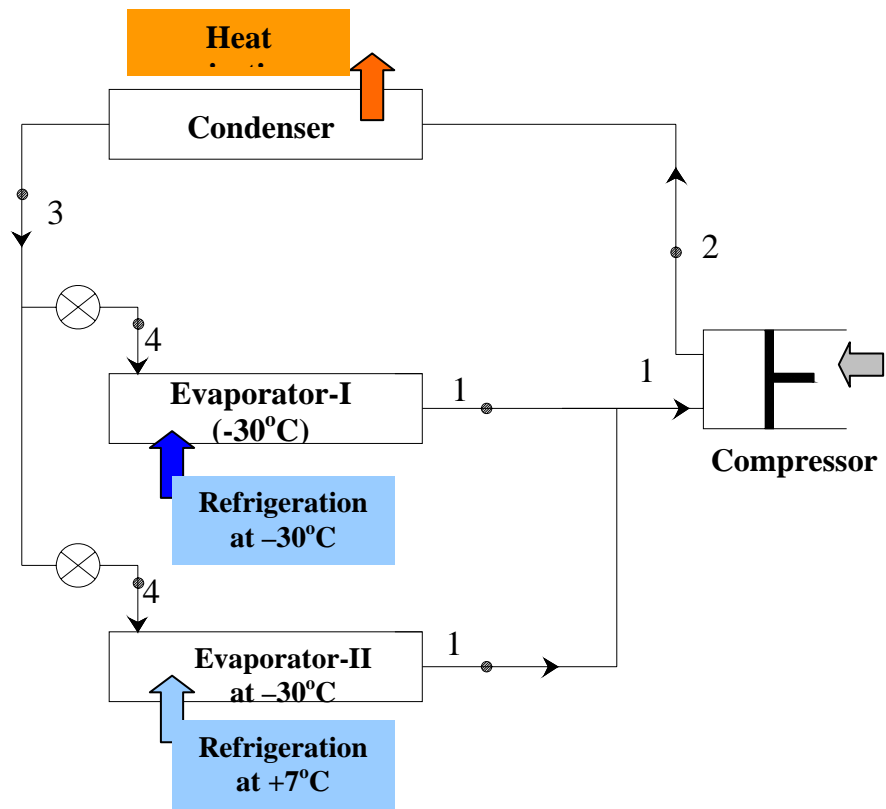


Fig.13.1(a) & (b): A single stage system with two evaporators



superheated region. Thus ultimately there may not be any improvement in system COP due to this arrangement. It is easy to see that this modification does not result in significant improvement in performance due to the fact that the refrigerant vapour at the intermediate pressure is reduced first using the PRV and again increased using compressor. Obviously this is inefficient. However, this system is still preferred to the earlier system due to proper operation of high temperature evaporator.

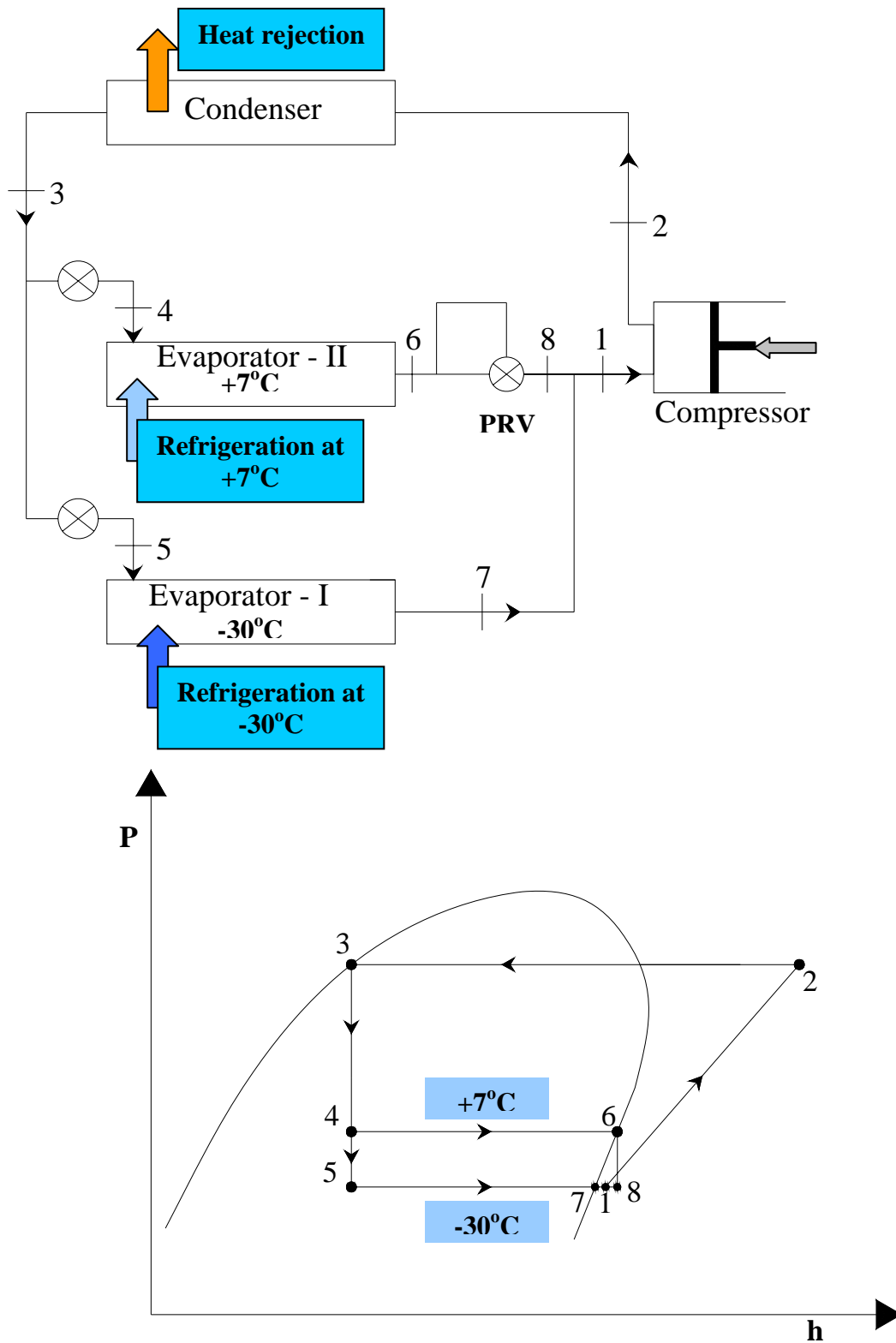


Fig.13.2(a) & (b): Multi-evaporator system with single compressor and individual expansion valves

The COP of the above system is given by:

$$\text{COP} = \frac{Q_{e,I} + Q_{e,II}}{W_c} = \frac{\dot{m}_I(h_7 - h_5) + \dot{m}_{II}(h_6 - h_4)}{(\dot{m}_I + \dot{m}_{II})(h_2 - h_1)} \quad (13.2)$$

where  $\dot{m}_I$  and  $\dot{m}_{II}$  are the refrigerant mass flow rates through evaporator I and II respectively. They are given by:

$$\dot{m}_I = \frac{Q_{e,I}}{(h_7 - h_5)} \quad (13.3)$$

$$\dot{m}_{II} = \frac{Q_{e,II}}{(h_6 - h_4)} \quad (13.4)$$

Enthalpy at point 2 (inlet to compressor) is obtained by applying mass and energy balance to the mixing of two refrigerant streams, i.e.,

$$h_2 = \frac{\dot{m}_I h_7 + \dot{m}_{II} h_8}{\dot{m}_I + \dot{m}_{II}} \quad (13.5)$$

If the expansion across PRV is isenthalpic, then specific enthalpy  $h_8$  will be equal to  $h_6$ .

### 13.2.2. Multiple expansion valves:

Figures 13.3 (a) and (b) show system schematic and P-h diagram of a multi-evaporator with a single compressor and multiple expansion valves. It can be seen from the P-h diagram that the advantage of this system compared to the system with individual expansion valves is that the refrigeration effect of the low temperature evaporator increases as saturated liquid enters the low stage expansion valve. Since the flash gas is removed at state 4, the low temperature evaporator operates more efficiently.

The COP of this system is given by:

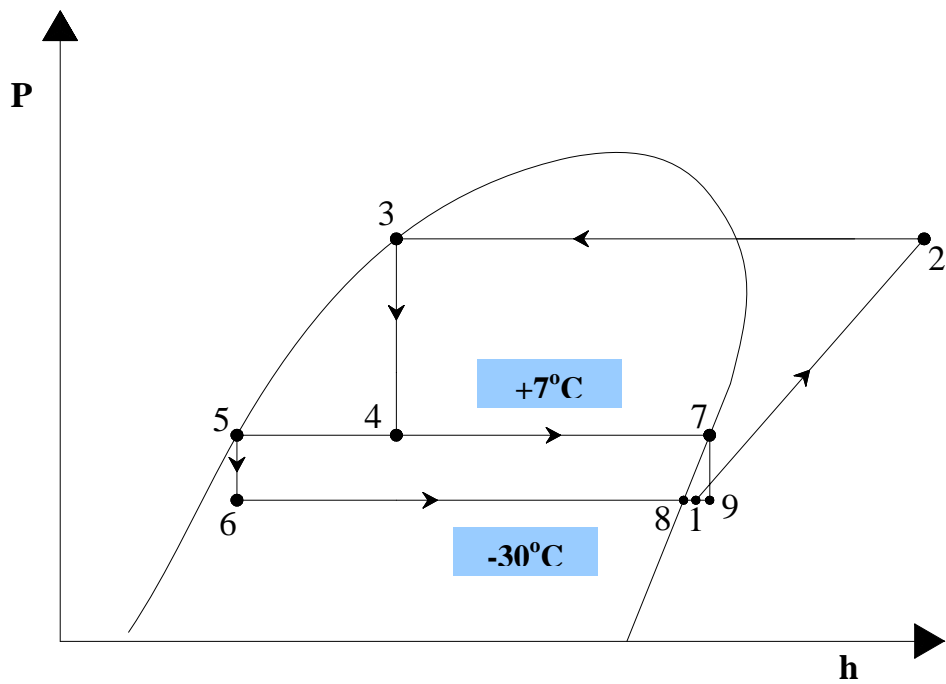
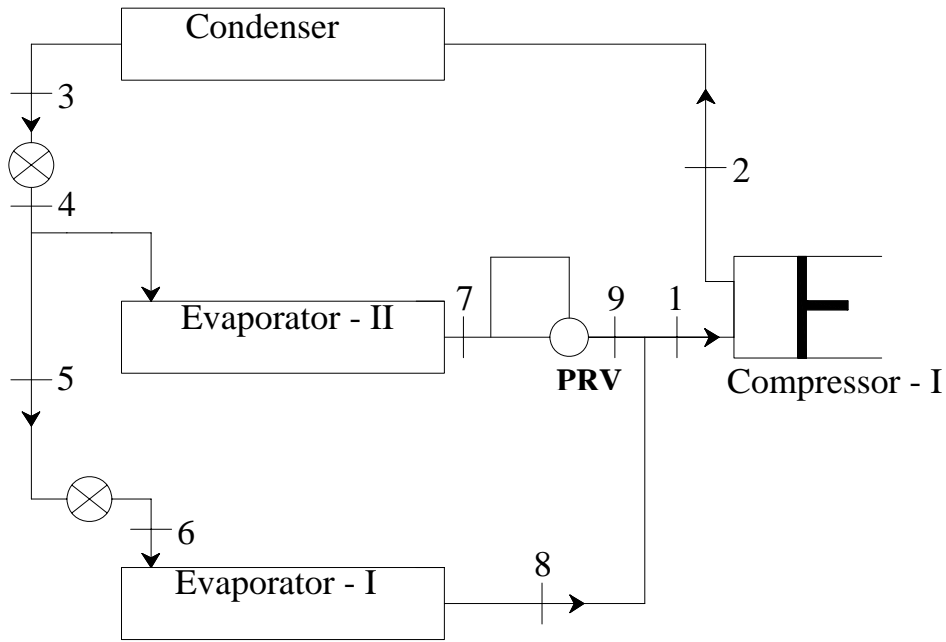
$$\text{COP} = \frac{Q_{e,I} + Q_{e,II}}{W_c} = \frac{\dot{m}_I(h_8 - h_6) + \dot{m}_{II}(h_7 - h_4)}{(\dot{m}_I + \dot{m}_{II})(h_2 - h_1)} \quad (13.6)$$

where  $\dot{m}_I$  and  $\dot{m}_{II}$  are the refrigerant mass flow rates through evaporator I and II respectively. They are given by:

$$\dot{m}_I = \frac{Q_{e,I}}{(h_8 - h_6)} \quad (13.7)$$

$$\dot{m}_{II} = \frac{Q_{e,II}}{(h_7 - h_4)} \quad (13.8)$$





**Fig.13.3(a) & (b):** Multi-evaporator system with single compressor and multiple expansion valves

Enthalpy at point 2 (inlet to compressor) is obtained by applying mass and energy balance to the mixing of two refrigerant streams, i.e.,

$$h_2 = \frac{\dot{m}_I h_8 + \dot{m}_{II} h_9}{\dot{m}_I + \dot{m}_{II}} \quad (13.9)$$

If the expansion across PRV is isenthalpic, then specific enthalpy  $h_7$  will be equal to  $h_9$ .

COP obtained using the above multi-evaporator systems is not much higher compared to single stage system as refrigerant vapour at intermediate pressure is first

throttled then compressed, and compressor inlet is in superheated region. Performance can be improved significantly if multiple compressors are used in place of a single compressor.

### 13.3. Multi-evaporator system with multi-compression, intercooling and flash gas removal

Figures 13.4(a) and (b) show the schematic and P-h diagram of a multi-evaporator system which employs multiple compressors, a flash tank for flash gas removal and intercooling. This system is good for low temperature lift applications with different refrigeration loads. For example one evaporator operating at say  $-40^{\circ}\text{C}$  for quick freezing of food products and other evaporator operating at  $-25^{\circ}\text{C}$  for storage of frozen food. As shown in the system schematic, the pressure in the high temperature evaporator (Evaporator-II) is same as that of flash tank. Superheated vapour from the low-stage compressor is cooled to the saturation temperature in the flash tank. The low temperature evaporator operates efficiently as flash gas is removed in the flash tank. In addition the high-stage compressor (Compressor-II) operates efficiently as the suction vapour is saturated. Even though the high stage compressor has to handle higher mass flow rate due to de-superheating of refrigerant in the flash tank, still the total power input to the system can be reduced substantially, especially with refrigerants such as ammonia.

The COP of this system is given by:

$$\text{COP} = \frac{Q_{e,I} + Q_{e,II}}{W_{c,I} + W_{c,II}} = \frac{\dot{m}_I(h_1 - h_8) + \dot{m}_{e,II}(h_3 - h_6)}{\dot{m}_I(h_2 - h_1) + \dot{m}_{II}(h_4 - h_3)} \quad (13.10)$$

where  $\dot{m}_I$  and  $\dot{m}_{e,II}$  are the refrigerant mass flow rates through evaporator I and II respectively. They are given by:

$$\dot{m}_I = \frac{Q_{e,I}}{(h_8 - h_6)} \quad (13.11)$$

$$\dot{m}_{e,II} = \frac{Q_{e,II}}{(h_3 - h_6)} \quad (13.12)$$

$\dot{m}_{II}$  is the mass flow rate of refrigerant through the high-stage compressor which can be obtained by taking a control volume which includes the flash tank and high temperature evaporator (as shown by dashed line in the schematic) and applying mass and energy balance:

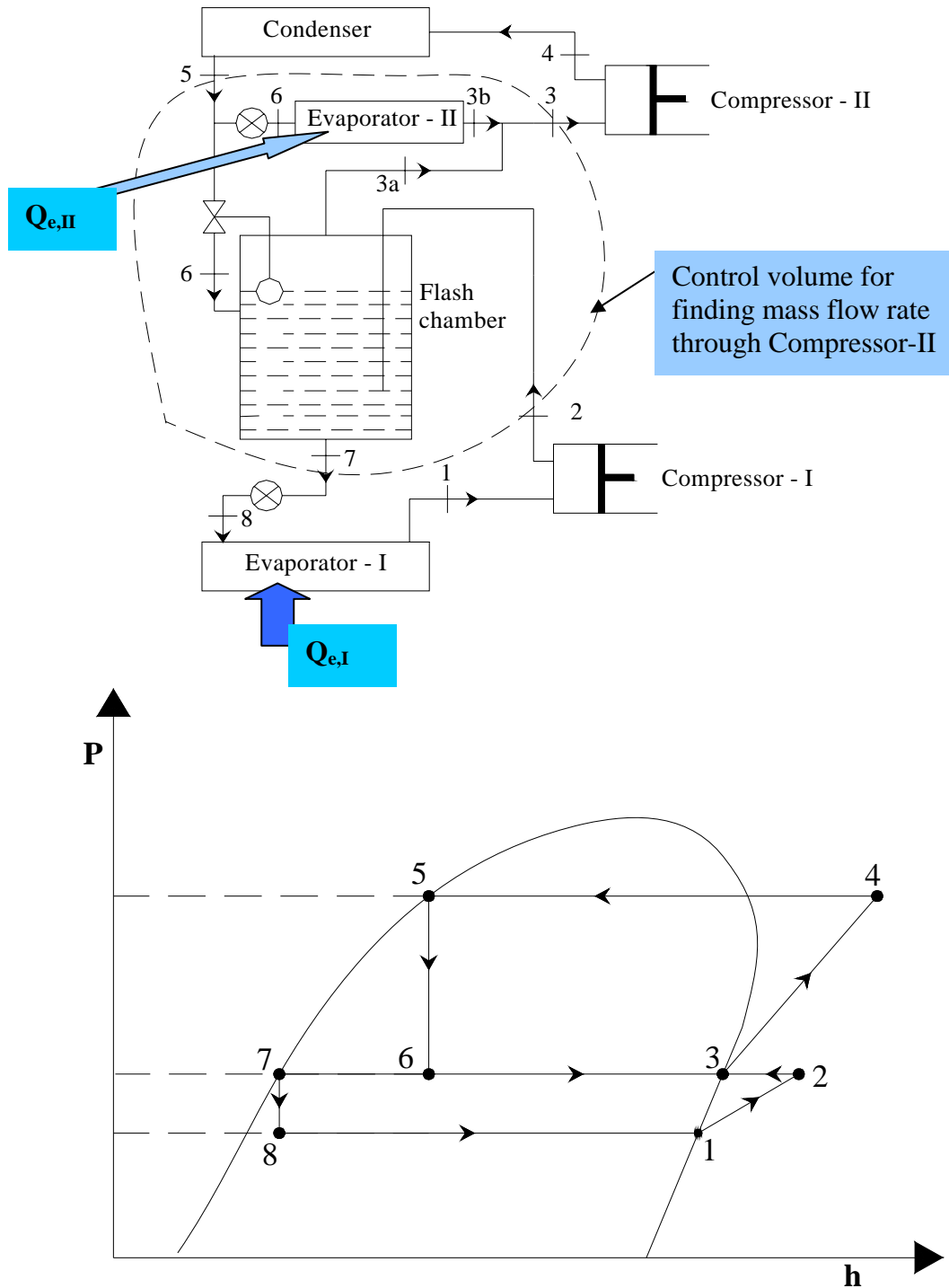
mass balance:

$$\dot{m}_5 + \dot{m}_2 = \dot{m}_7 + \dot{m}_3; \quad \dot{m}_5 = \dot{m}_{II} = \dot{m}_3 \quad \& \quad \dot{m}_2 = \dot{m}_I = \dot{m}_7 \quad (13.13)$$

energy balance:

$$\dot{m}_5 h_5 + \dot{m}_2 h_2 + Q_{e,II} = \dot{m}_7 h_7 + \dot{m}_3 h_3 \quad (13.14)$$

from known operating temperatures and evaporator loads ( $Q_{e,I}$  and  $Q_{e,II}$ ) one can get the mass flow rate through the high stage compressor and system COP from the above equations.



*Fig.13.4(a) & (b): Multi-evaporator system with multiple compressors and a flash tank for flash gas removal and intercooling*

## 13.4. Multi-evaporator system with individual compressors and multiple expansion valves

Figures 13.5(a) and (b) show the schematic and P-h diagram of a multi-evaporator system which employs individual compressors and multiple expansion valves.

The COP of this combined system is given by:

$$\text{COP} = \frac{Q_{e,I} + Q_{e,II}}{W_{c,I} + W_{c,II}} = \frac{\dot{m}_I(h_3 - h_9) + \dot{m}_{II}(h_1 - h_7)}{\dot{m}_I(h_4 - h_3) + \dot{m}_{II}(h_2 - h_1)} \quad (13.15)$$

where  $\dot{m}_I$  and  $\dot{m}_{II}$  are the refrigerant mass flow rates through evaporator I and II respectively. They are given by:

$$\dot{m}_I = \frac{Q_{e,I}}{(h_3 - h_9)} \quad (13.16)$$

$$\dot{m}_{II} = \frac{Q_{e,II}}{(h_1 - h_7)} \quad (13.17)$$

The inlet to the condenser (state 5) is obtained by applying mass and energy balance to the process of mixing of refrigerant vapours from Compressors I and II.

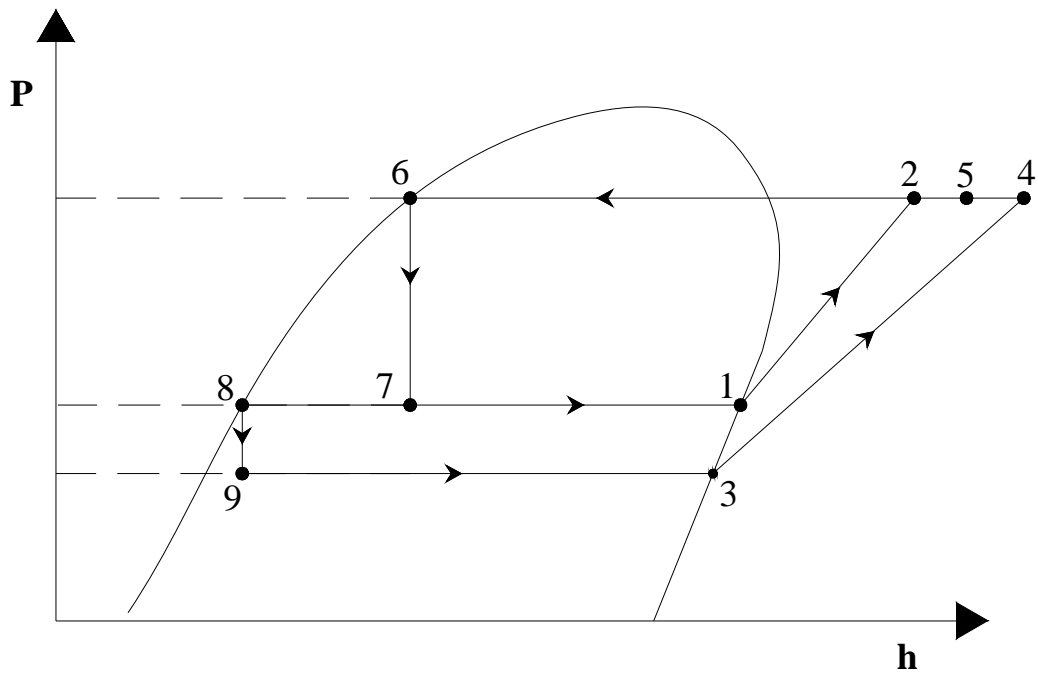
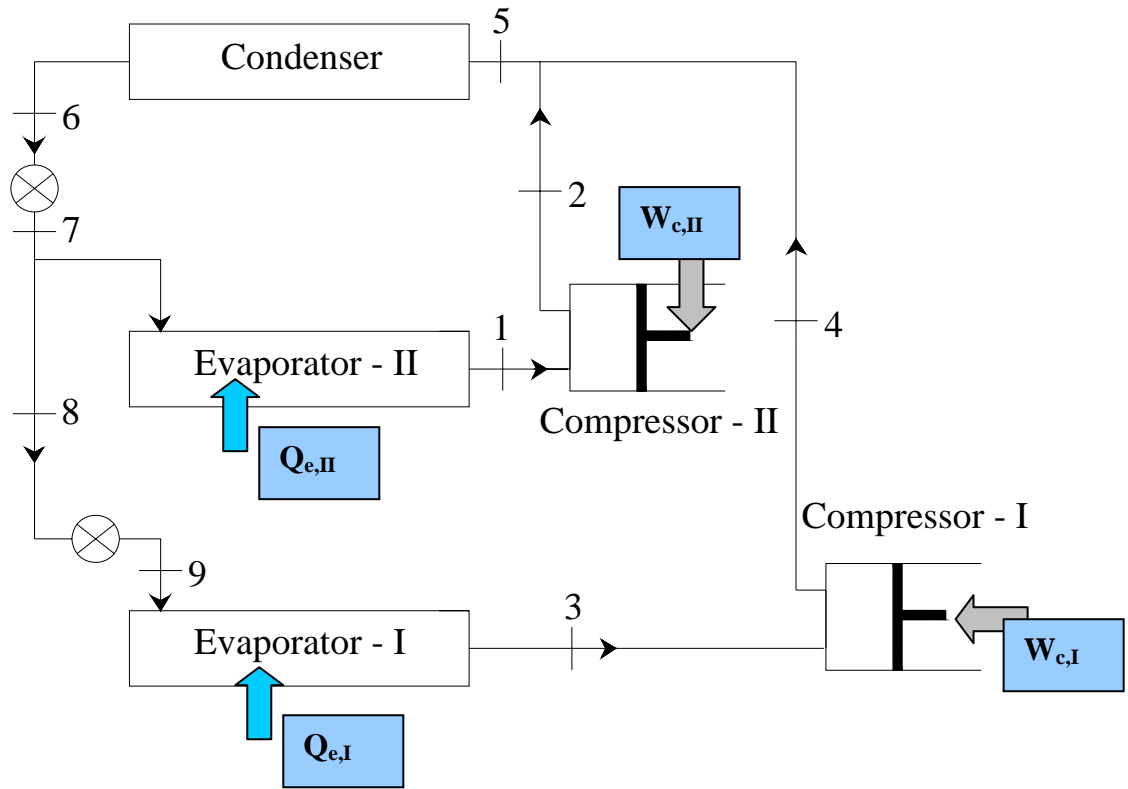
## 13.5. Limitations of multi-stage systems

Though multi-stage systems have been very successful, they have certain limitations. These are:

- a) Since only one refrigerant is used throughout the system, the refrigerant used should have high critical temperature and low freezing point.
- b) The operating pressures with a single refrigerant may become too high or too low. Generally only R12, R22 and NH<sub>3</sub> systems have been used in multi-stage systems as other conventional working fluids may operate in vacuum at very low evaporator temperatures. Operation in vacuum leads to leakages into the system and large compressor displacement due to high specific volume.
- c) Possibility of migration of lubricating oil from one compressor to other leading to compressor break-down.

The above limitations can be overcome by using cascade systems.





*Fig.13.5(a) & (b): Multi-evaporator system with individual compressors and multiple expansion valves*

## 13.6. Cascade Systems

In a cascade system a series of refrigerants with progressively lower boiling points are used in a series of single stage units. The condenser of lower stage system is coupled to the evaporator of the next higher stage system and so on. The component where heat of condensation of lower stage refrigerant is supplied for vaporization of next level refrigerant is called as *cascade condenser*. Figures 13.6(a) and (b) show the schematic and P-h diagrams of a two-stage cascade refrigeration system. As shown, this system employs two different refrigerants operating in two individual cycles. They are thermally coupled in the cascade condenser. The refrigerants selected should have suitable pressure-temperature characteristics. An example of refrigerant combination is the use of carbon dioxide (NBP =  $-78.4^{\circ}\text{C}$ ,  $T_{\text{cr}} = 31.06^{\circ}\text{C}$ ) in low temperature cascade and ammonia (NBP =  $-33.33^{\circ}\text{C}$ ,  $T_{\text{cr}} = 132.25^{\circ}\text{C}$ ) in high temperature cascade. It is possible to use more than two cascade stages, and it is also possible to combine multi-stage systems with cascade systems.

### Applications of cascade systems:

- i. Liquefaction of petroleum vapours
- ii. Liquefaction of industrial gases
- iii. Manufacturing of dry ice
- iv. Deep freezing etc.

### Advantages of cascade systems:

- i. Since each cascade uses a different refrigerant, it is possible to select a refrigerant that is best suited for that particular temperature range. Very high or very low pressures can be avoided
- ii. Migration of lubricating oil from one compressor to the other is prevented

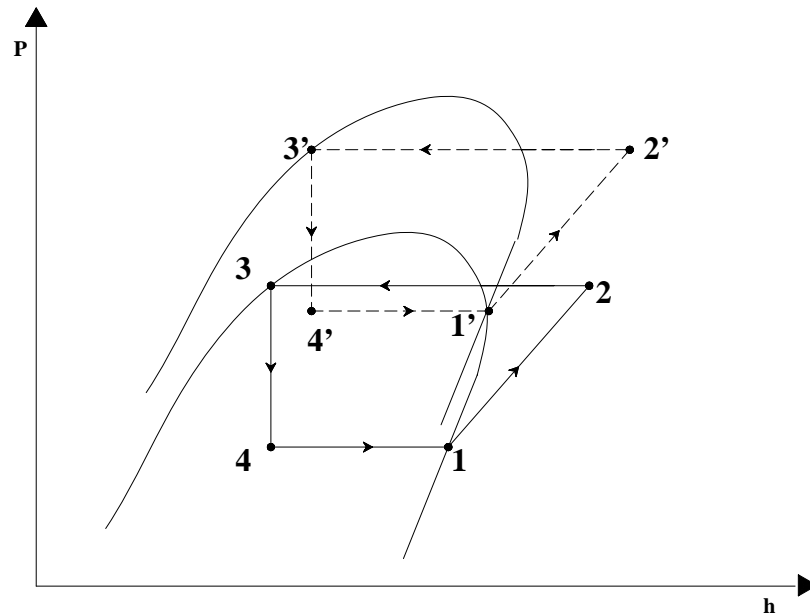
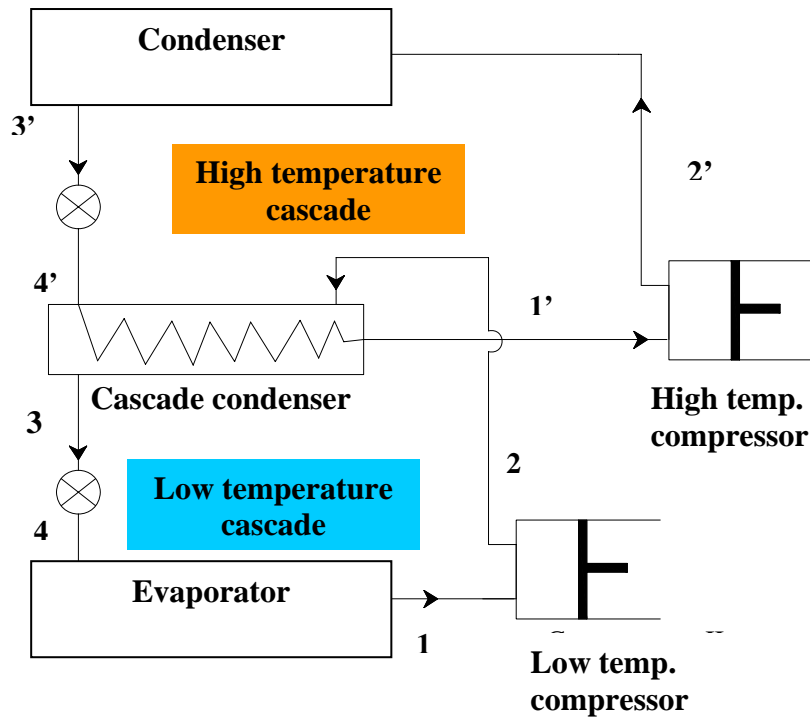
In practice, matching of loads in the cascade condenser is difficult, especially during the system pull-down. Hence the cascade condensers are normally oversized. In addition, in actual systems a temperature difference between the condensing and evaporating refrigerants has to be provided in the cascade condenser, which leads to loss of efficiency. In addition, it is found that at low temperatures, superheating (useful or useless) is detrimental from volumetric refrigeration effect point-of-view, hence in cascade systems, the superheat should be just enough to prevent the entry of liquid into compressor, and no more for all refrigerants.

### Optimum cascade temperature:

For a two-stage cascade system working on Carnot cycle, the optimum cascade temperature at which the COP will be maximum,  $T_{\text{cc,opt}}$  is given by:

$$T_{\text{cc,opt}} = \sqrt{T_e \cdot T_c} \quad (13.18)$$

where  $T_e$  and  $T_c$  are the evaporator temperature of low temperature cascade and condenser temperature of high temperature cascade, respectively.



*Fig.13.6(a) & (b): A two-stage cascade refrigeration system*

For cascade systems employing vapour compression refrigeration cycle, the optimum cascade temperature assuming equal pressure ratios between the stages is given by:

$$T_{cc,opt} = \left( \frac{b_1 + b_2}{\frac{b_2}{T_c} + \frac{b_1}{T_e}} \right) \quad (13.19)$$

where  $b_1$  and  $b_2$  are the constants in Clausius-Clayperon equation:  $\ln P = a - \frac{b}{T}$  for low and high temperature refrigerants, respectively.

### 13.7. Auto-cascade systems

An auto-cascade system may be considered as a variation of cascade system, in which a single compressor is used. The concept of auto-cascade system was first proposed by Ruhemann in 1946. Figure 13.7(a) shows the schematic of a two-stage auto-cascade cycle and Fig.137(b) shows the vapour pressure curves of the two

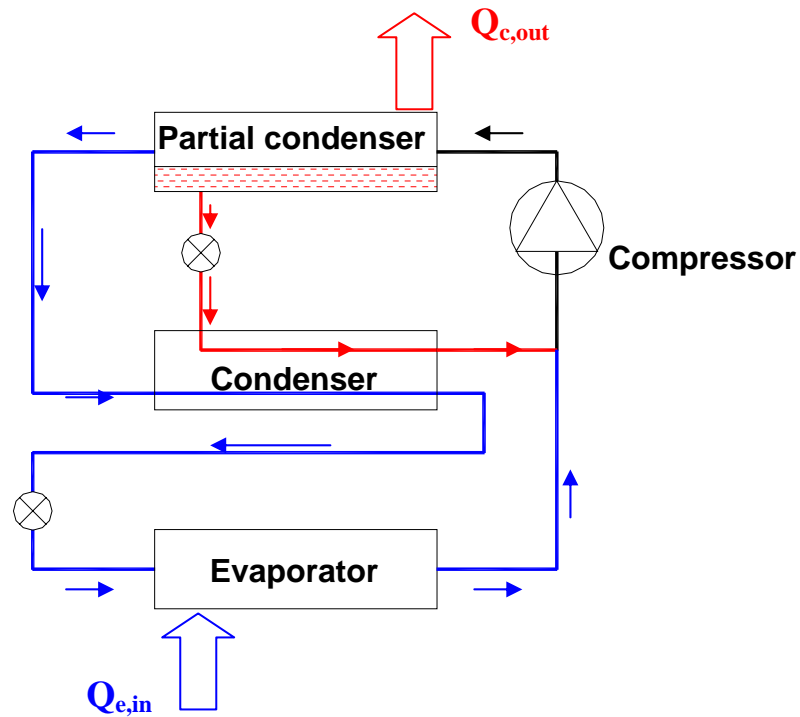


Fig.13.7(a): Schematic of a two-stage auto-cascade system

refrigerants used in the cycle on Dühring plot.

In a two-stage auto-cascade system two different working fluids; a low boiling point (low temperature) refrigerant and a high boiling point (high temperature) refrigerant are used. The vapour mixture consisting of both these refrigerants is compressed in the compressor to a discharge pressure ( $P_{\text{discharge}}$ ). When this high pressure mixture flows through the partial condenser, the high temperature refrigerant

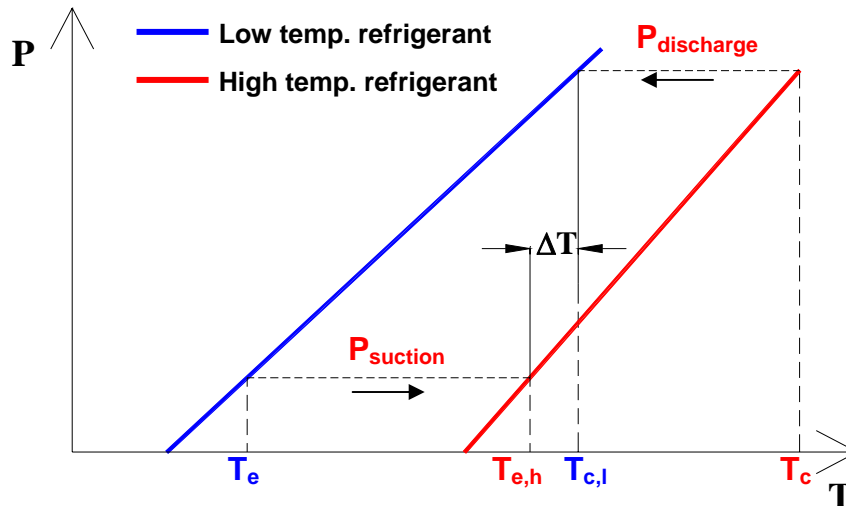


Fig.13.7(b): Schematic illustrating principle of two-stage auto-cascade system on Dühring plot

can condense by rejecting heat ( $Q_{c,out}$ ) to the external heat sink, if its partial pressure in the mixture is such that the saturation temperature corresponding to the partial pressure is higher than the external heat sink temperature. Since the saturation temperature of the low temperature refrigerant is much lower than the external heat sink temperature at its partial pressure, it cannot condense in the partial condenser, hence, remains as vapour. Thus it is possible theoretically to separate the high temperature refrigerant in liquid form from the partial condenser. Next this high temperature, high pressure liquid is expanded through the expansion valve into the condenser operating at a pressure  $P_{suction}$ . Due to the expansion of the high temperature refrigerant liquid from  $P_{discharge}$  to  $P_{suction}$ , its temperature drops to a sufficiently low value ( $T_{e,h}$ ) so that when the low temperature, high pressure refrigerant vapour comes in contact with the high temperature, low pressure refrigerant in the condenser it can condense at a temperature  $T_{c,l}$ . This condensed, high pressure, low temperature refrigerant is then throttled to the suction pressure and is then made to flow through the evaporator, where it can provide the required refrigeration effect at a very low temperature  $T_e$ . Both the high temperature refrigerant from condenser and low temperature refrigerant vapour from evaporator can be mixed as they are at the same pressure. This mixture is then compressed in the compressor to complete the cycle. Thus using a single compressor, it is possible to obtain refrigeration at very low temperatures using the auto-cascade system. In practice, more than two stages with more than two refrigerants can be used to achieve very high temperature lifts. However, in actual systems, it is not possible to separate pure refrigerants in the partial condenser as some amount of low temperature refrigerant condenses in the partial condenser and some amount of high temperature refrigerant leaves the partial condenser in vapour form. Thus everywhere in the system, one encounters refrigerant mixtures of varying composition. These systems are widely used in the liquefaction of natural gas.

## Questions:

1. Multi-evaporator systems are:

- a) Widely used when refrigeration is required at different temperatures
- b) When humidity control in the refrigerated space is required
- c) When the required temperature lift is small
- d) All of the above

**Ans.: a) and b)**

2. Multi-evaporator systems with a single compressor and a pressure reducing valve:

- a) Yield very high COPs compared to multi-evaporator, single stage systems
- b) Yield lower compressor discharge temperature compared to single stage systems
- c) Yield slightly higher refrigeration effect in the low temperature evaporator compared to single stage systems
- d) Yield slightly higher refrigeration effect in the high temperature evaporator compared to single stage systems

**Ans.: d)**

3. Compared to individual expansion valves, multiple expansion valves:

- a) Yield higher refrigeration effect in the low temperature evaporator
- b) Yield higher refrigeration effect in the high temperature evaporator
- c) Yield lower compressor discharge temperature
- d) Decrease the quality of refrigerant at the inlet to low temperature evaporator

**Ans.: a) and d)**

4. Compared to multi-evaporator and single compressor systems, multi-evaporator systems with multiple compressors:

- a) Yield higher COP
- b) Decrease maximum cycle temperature
- c) Yield higher refrigeration effect
- d) All of the above

**Ans.: a) and b)**

5. In multi-stage systems:

- a) The refrigerant used should have high critical temperature and high freezing point
- b) The refrigerant used should have high critical temperature and low freezing point
- c) There is a possibility of migration of lubricating oil from one compressor to other
- d) Operating pressures can be too high or too low

**Ans.: b), c) and d)**

6. In cascade systems:

- a) Different refrigerants are used in individual cascade cycles
- b) There is no mixing of refrigerants and no migration of lubricating oil
- c) Higher COPs compared to multi-stage systems can be obtained
- d) Operating pressures need not be too high or too low

**Ans.: a), b) and d)**

7. Cascade systems are widely used for:

- a) Large refrigeration capacity systems
- b) Applications requiring large temperature lifts
- c) Applications requiring very high efficiencies
- d) All of the above

**Ans.: b)**

8. For a two-stage cascade system working on Carnot cycle and between low and high temperatures of  $-90^{\circ}\text{C}$  and  $50^{\circ}\text{C}$ , the optimum cascade temperature at which the COP will be maximum is given by:

- a)  $-20^{\circ}\text{C}$
- b)  $-30^{\circ}\text{C}$

- c)  $-67^{\circ}\text{C}$
- d)  $0^{\circ}\text{C}$

**Ans.: b)**

9. In a two stage, auto-cascade system:

- a) Two compressors and two refrigerants are used
- b) A single compressor and a single refrigerant are used
- c) A single compressor and two refrigerants are used
- d) Two compressors and a single refrigerant are used

**Ans.: c)**

10. In a two stage, auto-cascade system:

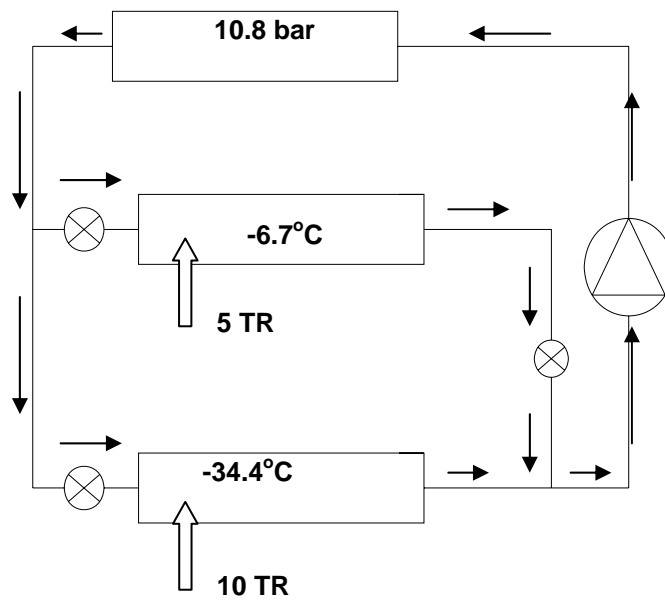
- a) Compressor compresses refrigerant mixture
- b) Refrigerants are separated in partial condenser
- c) Condensing temperature of low temperature refrigerant at discharge pressure is higher than the boiling temperature of high temperature refrigerant at suction pressure
- d) Condensing temperature of low temperature refrigerant at discharge pressure is lower than the boiling temperature of high temperature refrigerant at suction pressure

**Ans.: a), b) and c)**

11. The figure given below shows a multi-evaporator, vapour compression refrigeration system working with ammonia. The refrigeration capacity of the high temperature evaporator operating at  $-6.7^{\circ}\text{C}$  is 5 TR, while it is 10 TR for the low temperature evaporator operating at  $-34.4^{\circ}\text{C}$ . The condenser pressure is 10.8 bar. Assuming saturated conditions at the exit of evaporators and condenser, ammonia vapour to behave as an ideal gas with a gas constant of  $0.4882\text{ kJ/kg.K}$  and isentropic index ( $c_p/c_v$ ) of 1.29, and isentropic compression:

- a) Find the required power input to compressor in kW
- b) Find the required power input if instead of using a single compressor, individual compressors are used for low and high temperature evaporators.

Use the data given in the table:



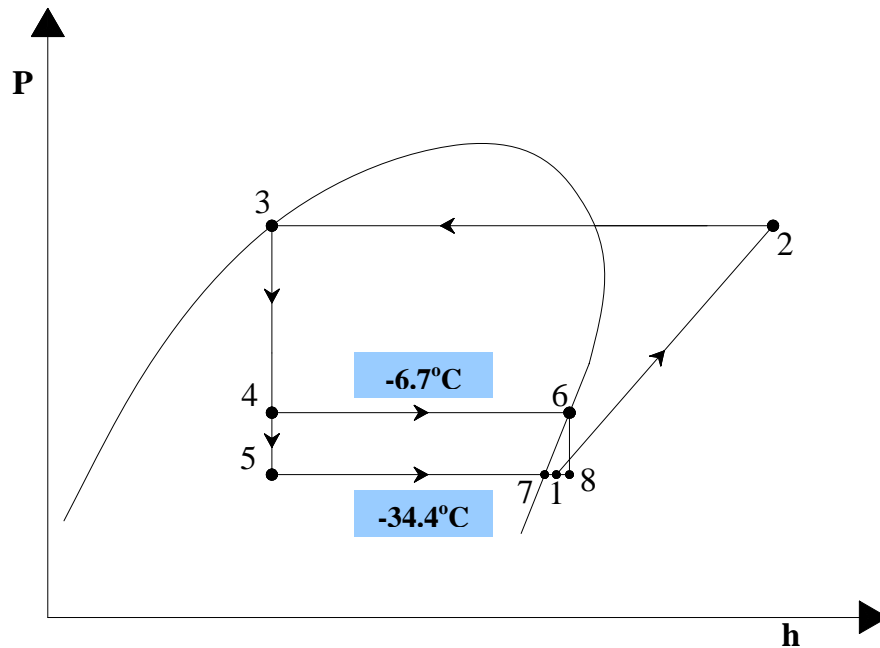
$T, ^\circ\text{C}$	$P_{\text{sat}}$ (kPa)	$h_f$ (kJ/kg) (sat.liquid)	$h_g$ (kJ/kg) sat. vapour
-34.4	95.98	44.0	1417
-6.7	331.8	169.1	1455
27.7	1080.0	330.4	1485

**Data for Problem 11**



Ans.:

a) **Single compressor:** The P-h diagram for the above system is shown below:



The required mass flow rate through the low temperature evaporator ( $m_{r,l}$ ) is given by:

$$m_{r,l} = Q_{e,l}/(h_7 - h_5) = (10 \times 3.517)/(1417 - 330.4) = \mathbf{0.03237 \text{ kg/s}}$$

The required mass flow rate through the high temperature evaporator ( $m_{r,h}$ ) is given by:

$$m_{r,h} = Q_{e,h}/(h_6 - h_4) = (5 \times 3.517)/(1455 - 330.4) = \mathbf{0.01564 \text{ kg/s}}$$

Assuming the refrigerant vapour to behave as an ideal gas, and assuming the variation in specific heat of the vapour to be negligible, the temperature of the refrigerant after mixing, i.e., at point 1 is given by:

$$T_1 = (m_{r,l}.T_7 + m_{r,h}.T_6)/(m_{r,l} + m_{r,h}) = \mathbf{247.6 \text{ K}}$$

Assuming isentropic compression and ideal gas behaviour, the power input to the compressor,  $W_c$  is given by:

$$W_c = m_r . R . T_1 \left( \frac{k}{k-1} \right) \left[ \left( \frac{P_c}{P_e} \right)^{\frac{k-1}{k}} - 1 \right]$$

where  $m_r$  is the refrigerant flow rate through the compressor ( $m_r = m_{r,l} + m_{r,h}$ ),  $R$  is the gas constant (0.4882 kJ/kg.K),  $P_c$  and  $P_e$  are the discharge and suction pressures and  $k$  is the isentropic index of compression ( $= 1.29$ ).

Substituting these values, the power input to the compressor is found to be:

$$W_c = 18.67 \text{ kW} \quad (\text{Ans.})$$

Since the refrigerant vapour is assumed to behave as an ideal gas with constant specific heat, and the compression process is assumed to be isentropic, the discharge temperature  $T_2$  can be obtained using the equation:

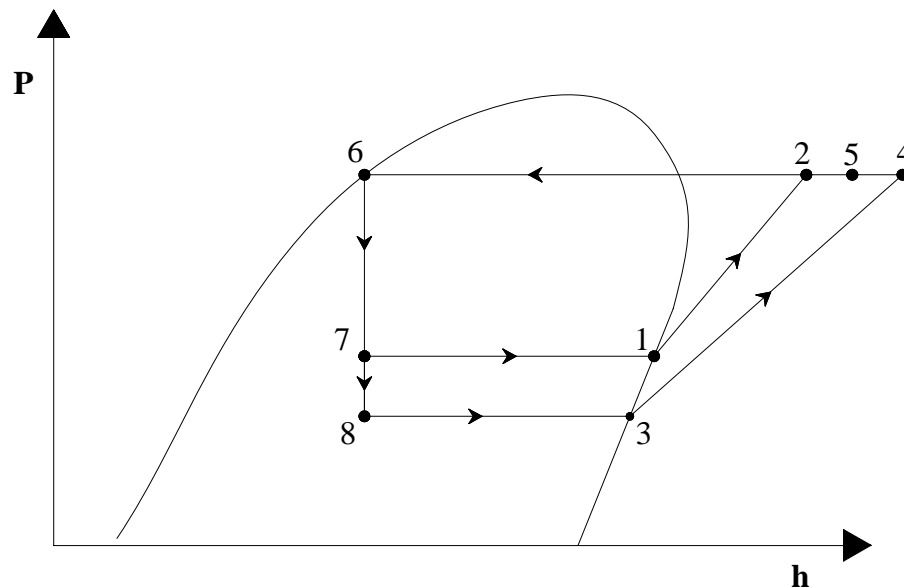
$$W_c = m_r \cdot C_p (T_2 - T_1) = 18.67 \text{ kW}$$

Substituting the values of  $m_r$ ,  $C_p$  ( $=2.1716 \text{ kJ/kg.K}$ ) and  $T_1$ , the discharge temperature is found to be:

$$T_2 = 427.67 \text{ K} = 153.5^\circ\text{C}$$

### b) Individual compressors:

The P-h diagram with individual compressors is shown below:



The mass flow rates through evaporators will be same as before.

The power input to low temperature compressor (process 3 to 4),  $W_{c,l}$  is given by:

$$W_{c,l} = m_{r,l} \cdot R \cdot T_3 \left( \frac{k}{k-1} \right) \left[ \left( \frac{P_c}{P_e} \right)^{\frac{k-1}{k}} - 1 \right]$$

substituting the values, we obtain:

$$W_{c,l} = 12.13 \text{ kW}$$

Similarly, for the high temperature compressor (process 1-2), the power input  $W_{c,h}$  is given by:

$$W_{c,h} = m_{r,h} \cdot R \cdot T_1 \left( \frac{k}{k-1} \right) \left[ \left( \frac{P_c}{P_{e,h}} \right)^{\frac{k-1}{k}} - 1 \right] = 2.75 \text{ kW}$$

Therefore total power input is given by:

$$W_c = W_{c,l} + W_{c,h} = 12.13 + 2.75 = 14.88 \text{ kW} \quad (\text{Ans.})$$

The compressor discharge temperatures for the low temperature and high temperature compressor are found to be:

$$T_4 = 411.16 \text{ K} = 138.0^\circ\text{C}$$

$$T_2 = 347.27 \text{ K} = 74.10^\circ\text{C}$$

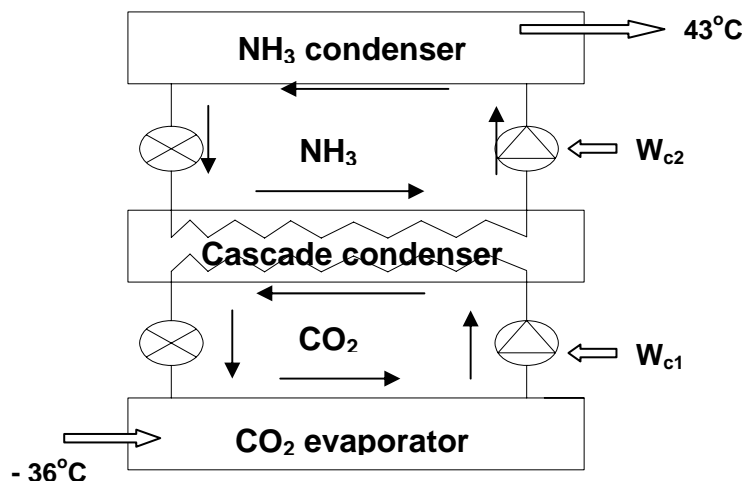
### Comments:

1. Using individual compressors in place of a single compressor, the power input to the system could be reduced considerably ( $\approx 20.3\%$ ).
2. In addition, the maximum compressor discharge temperature also could be reduced by about  $15^\circ\text{C}$ .
3. In addition to this, the high temperature compressor operates at much lower compression ratio, leading to low discharge temperatures and high volumetric efficiency.

These are the advantages one could get by using individual compressors, instead of a pressure regulating valve and a single compressor. However, in actual systems these benefits will be somewhat reduced since smaller individual compressors generally have lower isentropic and volumetric efficiencies.

4. A cascade refrigeration system shown in the figure given below uses  $\text{CO}_2$  as refrigerant for the low-stage and  $\text{NH}_3$  as the refrigerant for the high-stage. The system has to provide a refrigeration capacity of **10 TR** and maintain the refrigerated space at  $-36^\circ\text{C}$ , when the ambient temperature (heat sink) is at  $43^\circ\text{C}$ . A temperature difference of **7 K** is required for heat transfer in the evaporator, condenser and the cascade condenser. Assume the temperature lift ( $T_{\text{cond}} - T_{\text{evap}}$ ) to be same for both  $\text{CO}_2$  and  $\text{NH}_3$  cycles and find a) Total power input to the system; b) Power input if the cascade system is replaced with a single stage  $\text{NH}_3$  system operating between same refrigerated space and heat sink.

The actual COP of the vapour compression system ( $\text{COP}_{\text{act}}$ ) can be estimated using



the equation:

$$\text{COP}_{\text{act}} = 0.85 \text{COP}_{\text{Carnot}} \left[ 1 - \frac{T_c - T_e}{265} \right]$$

where

$\text{COP}_{\text{Carnot}}$  = Carnot COP

$T_c$  = Condensing Temp.,

$T_e$  = Evaporator Temp.

**Ans.:** Since a temperature difference of 7 K is required for heat transfer, the CO<sub>2</sub> evaporator and NH<sub>3</sub> condenser temperatures are given by:

$$T_{e,\text{CO}_2} = -36 - 7 = -43^\circ\text{C} = 230 \text{ K}$$

$$T_{c,\text{NH}_3} = 43 + 7 = 50^\circ\text{C} = 323 \text{ K}$$

In the cascade condenser,

$$T_{c,\text{CO}_2} = T_{e,\text{NH}_3} + 7$$

Since the temperature lifts of CO<sub>2</sub> and NH<sub>3</sub> cycles are same,

$$(T_{c,\text{CO}_2} - T_{e,\text{CO}_2}) = (T_{c,\text{NH}_3} - T_{e,\text{NH}_3})$$

From the above 4 equations, we obtain:

$$T_{c,\text{CO}_2} = 280 \text{ K}$$

$$T_{e,\text{NH}_3} = 273 \text{ K}$$

Substituting the values of temperatures in the expression for actual COP, we obtain:

$$\text{COP}_{\text{CO}_2} = 3.17, \text{ and}$$

$$\text{COP}_{\text{NH}_3} = 3.77$$

The power input to CO<sub>2</sub> compressor is given by,

$$W_{c,\text{CO}_2} = Q_{e,\text{CO}_2} / \text{COP}_{\text{CO}_2} = 10 \times 3.517 / 3.17 = 11.1 \text{ kW}$$

Since the heat rejected by the condenser of CO<sub>2</sub> system is the refrigeration load for the evaporator of NH<sub>3</sub> system, the required refrigeration capacity of NH<sub>3</sub> system is given by:

$$Q_{e,\text{NH}_3} = Q_{c,\text{CO}_2} = Q_{e,\text{CO}_2} + W_{c,\text{CO}_2} = 46.27 \text{ kW}$$

Hence power input to NH<sub>3</sub> compressor is given by:

$$W_{c,\text{NH}_3} = Q_{e,\text{NH}_3} / \text{COP}_{\text{NH}_3} = 46.27 / 3.77 = 12.27 \text{ kW}$$

Therefore, the total power input to the system is given by:

$$W_{c,\text{total}} = W_{c,\text{CO}_2} + W_{c,\text{NH}_3} = 23.37 \text{ kW} \quad (\text{Ans.})$$

b) If instead of a cascade system, a single stage NH<sub>3</sub> is used then, the actual COP of the system is:

$$\text{COP}_{\text{NH}_3,1\text{st}} = 1.363$$

Power input to single stage ammonia system is given by:

$$W_{c,\text{NH}_3,1\text{st}} = Q_e / \text{COP}_{\text{NH}_3,1\text{st}} = 35.17 / 1.363 = \mathbf{25.8 \text{ kW}} \quad (\text{Ans.})$$

### Comments:

- 1) Using a cascade system the power consumption could be reduced by about 9.5 %.
- 2) More importantly, in actual systems, the compared to the single stage system, the compressors of cascade systems will be operating at much smaller pressure ratios, yielding high volumetric and isentropic efficiencies and lower discharge temperatures. Thus cascade systems are obviously beneficial compared to single stage systems for large temperature lift applications.
3. The performance of the cascade system can be improved by reducing the temperature difference for heat transfer in the evaporator, condenser and cascade condenser, compared to larger compressors.

Lesson

14

Vapour Absorption  
Refrigeration Systems

## The objectives of this lesson are to:

1. Introduce vapour absorption refrigeration systems (*Section 14.1*)
2. Explain the basic principle of a vapour absorption refrigeration system (*Section 14.2*)
3. Compare vapour compression refrigeration systems with continuous vapour absorption refrigeration systems (*Section 14.2*)
4. Obtain expression for maximum COP of ideal absorption refrigeration system (*Section 14.3*)
5. Discuss properties of ideal and real refrigerant-absorbent mixtures (*Section 14.4*)
6. Describe a single stage vapour absorption refrigeration system with solution heat exchanger (*Section 14.5*)
7. Discuss the desirable properties of refrigerant-absorbent pairs for vapour absorption refrigeration systems and list the commonly used working fluids (*Section 14.6*)

At the end of the lecture, the student should be able to:

1. List salient features of vapour absorption refrigeration systems and compare them with vapour compression refrigeration systems
2. Explain the basic principle of absorption refrigeration systems and describe intermittent and continuous vapour absorption refrigeration systems
3. Find the maximum possible COP of vapour absorption refrigeration systems
4. Explain the differences between ideal and real mixtures using pressure-composition and enthalpy-composition diagrams
5. Draw the schematic of a complete, single stage vapour absorption refrigeration system and explain the function of solution heat exchanger
6. List the desirable properties of working fluids for absorption refrigeration systems and list some commonly used fluid pairs

### 14.1. Introduction

Vapour Absorption Refrigeration Systems (VARs) belong to the class of vapour cycles similar to vapour compression refrigeration systems. However, unlike vapour compression refrigeration systems, the required input to absorption systems is in the form of heat. Hence these systems are also called as heat operated or thermal energy driven systems. Since conventional absorption systems use liquids for absorption of refrigerant, these are also sometimes called as wet absorption systems. Similar to vapour compression refrigeration systems, vapour absorption refrigeration systems have also been commercialized and are widely used in various refrigeration and air conditioning applications. Since these systems run on low-grade thermal energy, they are preferred when low-grade energy such as waste heat or solar energy is available. Since conventional absorption systems use natural refrigerants such as water or ammonia they are environment friendly.

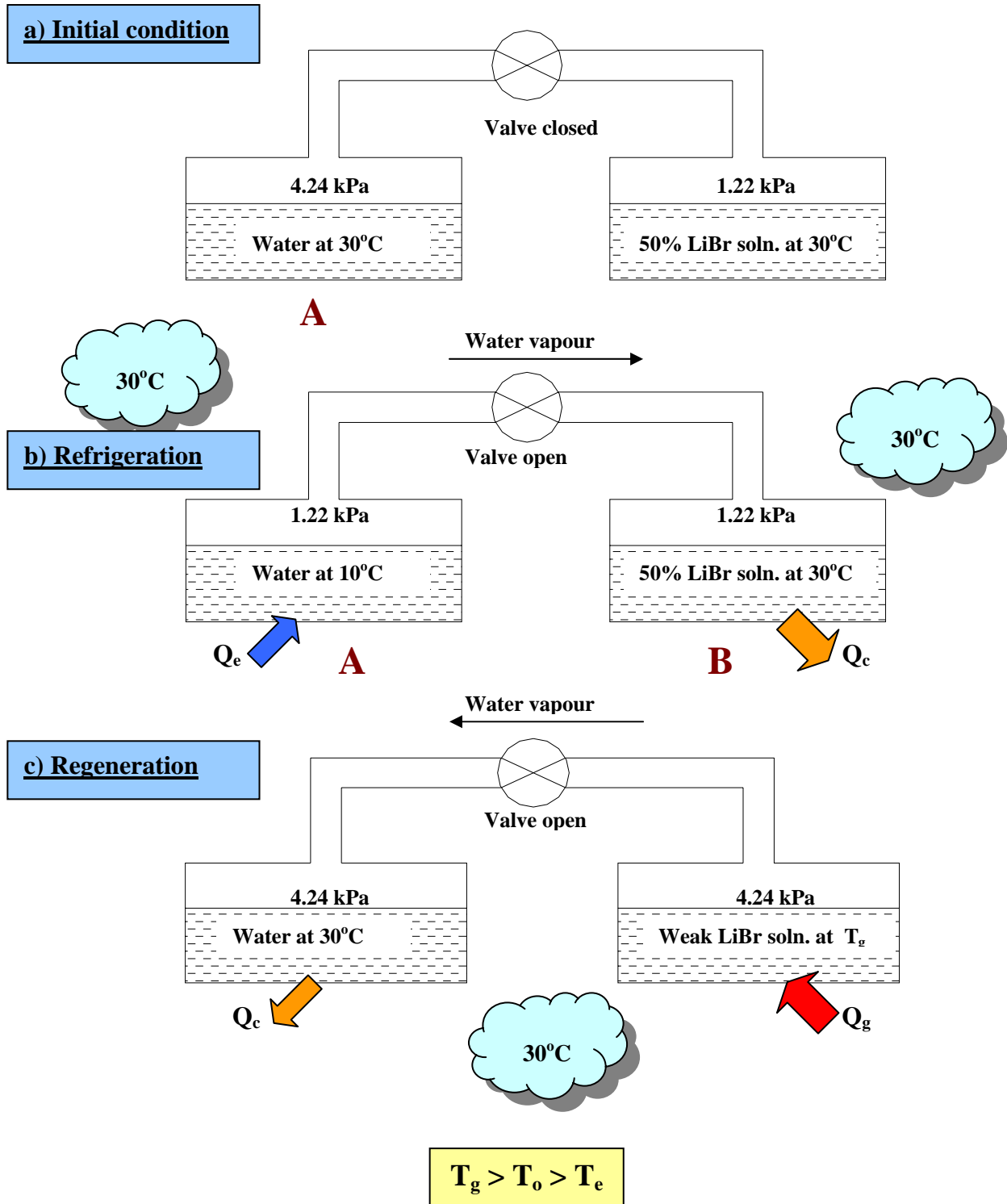
In this lesson, the basic working principle of absorption systems, the maximum COP of ideal absorption refrigeration systems, basics of properties of mixtures and simple absorption refrigeration systems will be discussed.

## 14.2. Basic principle

When a solute such as lithium bromide salt is dissolved in a solvent such as water, the boiling point of the solvent (water) is elevated. On the other hand, if the temperature of the solution (solvent + solute) is held constant, then the effect of dissolving the solute is to reduce the vapour pressure of the solvent below that of the saturation pressure of pure solvent at that temperature. If the solute itself has some vapour pressure (i.e., volatile solute) then the total pressure exerted over the solution is the sum total of the partial pressures of solute and solvent. If the solute is non-volatile (e.g. lithium bromide salt) or if the boiling point difference between the solution and solvent is large ( $\geq 300^\circ\text{C}$ ), then the total pressure exerted over the solution will be almost equal to the vapour pressure of the solvent only. In the simplest absorption refrigeration system, refrigeration is obtained by connecting two vessels, with one vessel containing pure solvent and the other containing a solution. Since the pressure is almost equal in both the vessels at equilibrium, the temperature of the solution will be higher than that of the pure solvent. This means that if the solution is at ambient temperature, then the pure solvent will be at a temperature lower than the ambient. Hence refrigeration effect is produced at the vessel containing pure solvent due to this temperature difference. The solvent evaporates due to heat transfer from the surroundings, flows to the vessel containing solution and is absorbed by the solution. This process is continued as long as the composition and temperature of the solution are maintained and liquid solvent is available in the container.

For example, Fig.14.1 shows an arrangement, which consists of two vessels A and B connected to each other through a connecting pipe and a valve. Vessel A is filled with pure water, while vessel B is filled with a solution containing on mass basis 50 percent of water and 50 percent lithium bromide (LiBr salt). Initially the valve connecting these two vessels is closed, and both vessels are at thermal equilibrium with the surroundings, which is at  $30^\circ\text{C}$ . At  $30^\circ\text{C}$ , the saturation pressure of water is 4.24 kPa, and the equilibrium vapour pressure of water-lithium bromide solution (50 : 50 by mass) at  $30^\circ\text{C}$  is 1.22 kPa.





*Fig.14.1: Basic principle of vapour absorption systems*

Thus at initial equilibrium condition, the pressure in vessel A is 4.24 kPa, while it is 1.22 kPa in vessel B. Now the valve between vessels A and B is opened. Initially due to pressure difference water vapour will flow from vessel A to vessel B, and this vapour will be absorbed by the solution in vessel B. Since absorption in this case is exothermic, heat will be released in vessel B. Now suppose by some means the concentration and temperature of vessel B are maintained constant at 50 % and 30°C, respectively. Then at equilibrium, the pressure in the entire system (vessels A and B) will be 1.22 kPa (equilibrium pressure of 50 % LiBr solution at 30°C). The

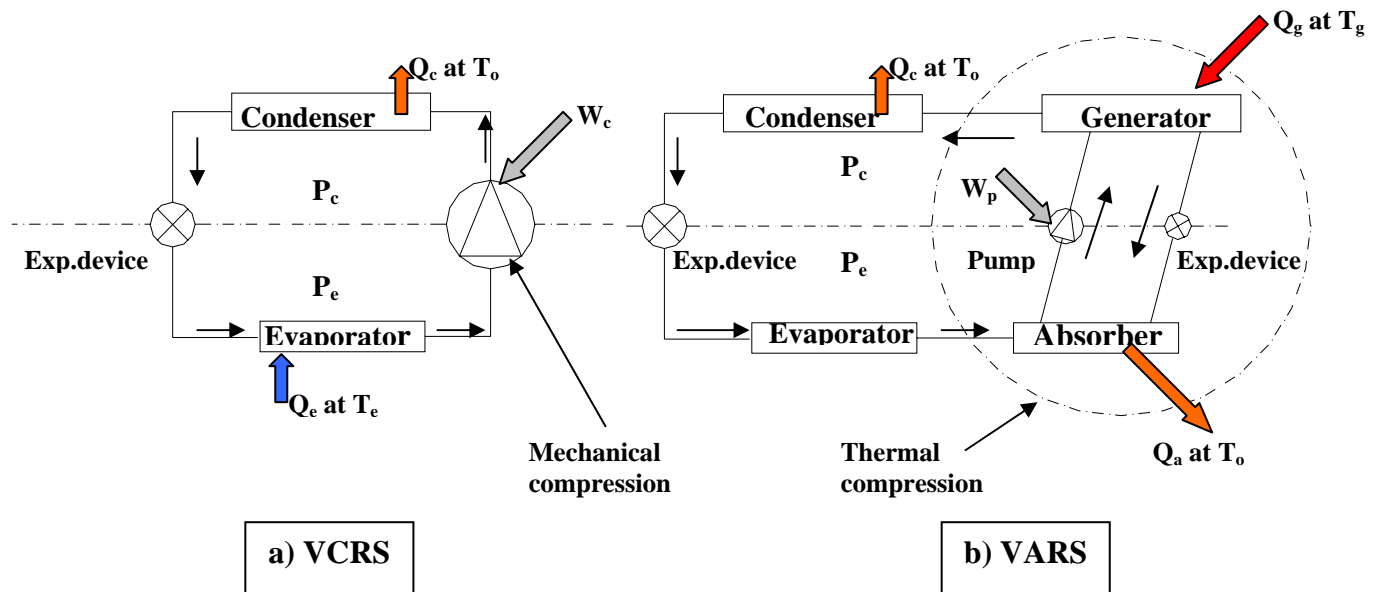
temperature of water in vessel A will be the saturation temperature corresponding to 1.22 kPa, which is equal to about 10°C, as shown in the figure. Since the water temperature in A is lower than the surroundings, a refrigeration effect ( $Q_e$ ) can be produced by transferring heat from the surroundings to water at 10°C. Due to this heat transfer, water vaporizes in A, flows to B and is absorbed by the solution in B. The exothermic heat of absorption ( $Q_a$ ) is rejected to the surroundings.

Now for the above process to continue, there should always be pure water in vessel A, and vessel B must be maintained always at 50 percent concentration and 30°C. This is not possible in a closed system such as the one shown in Fig.14.1. In a closed system with finite sized reservoirs, gradually the amount of water in A decreases and the solution in B becomes diluted with water. As a result, the system pressure and temperature of water in A increase with time. Hence the refrigeration effect at A reduces gradually due to the reduced temperature difference between the surroundings and water. Thus refrigeration produced by systems using only two vessels is intermittent in nature. In these systems, after a period, the refrigeration process has to be stopped and both the vessels A and B have to be brought back to their original condition. This requires removal of water absorbed in B and adding it back to vessel A in liquid form, i.e., a process of regeneration as shown in Fig.14.1(c).

Assume that before regeneration is carried out, the valve between A and B is closed and both A and B are brought in thermal equilibrium with the surroundings (30°C), then during the regeneration process, heat at high temperature  $T_g$  is supplied to the dilute LiBr solution in B, as a result water vapour is generated in B. The vapour generated in B is condensed into pure water in A by rejecting heat of condensation to the surroundings. This process has to be continued till all the water absorbed during the refrigeration process (14.1(b)) is transferred back to A. Then to bring the system back to its original condition, the valve has to be closed and solution in vessel B has to be cooled to 30°C. If we assume a steady-flow process of regeneration and neglect temperature difference for heat transfer, then the temperature of water in A will be 30°C and pressure inside the system will be 4.24 kPa. Then the temperature in vessel B,  $T_g$  depends on the concentration of solution in B. The amount of heat transferred during refrigeration and regeneration depends on the properties of solution and the operating conditions. It can be seen that the output from this system is the refrigeration obtained  $Q_e$  and the input is heat supplied to vessel B during vapour regeneration process,  $Q_g$ .

The system described may be called as an Intermittent Absorption Refrigeration System. The solvent is the refrigerant and the solute is called as absorbent. These simple systems can be used to provide refrigeration using renewable energy such as solar energy in remote and rural areas. As already explained, these systems provided refrigeration intermittently, if solar energy is used for regenerating the refrigerant, then regeneration process can be carried out during the day and refrigeration can be produced during the night.

Though the intermittent absorption refrigeration systems discussed above are simple in design and inexpensive, they are not useful in applications that require continuous refrigeration. Continuous refrigeration can be obtained by having a modified system with two pairs of vessels A and B and additional expansion valves and a solution pump.



**Figs.14.2:** a) Vapour compression refrigeration system (VCRS)  
 b) Vapour Absorption Refrigeration System (VARs)

Figure 14.2(a) and (b) show a continuous output vapour compression refrigeration system and a continuous output vapour absorption refrigeration system. As shown in the figure in a continuous absorption system, low temperature and low pressure refrigerant with low quality enters the evaporator and vaporizes by producing useful refrigeration  $Q_e$ . From the evaporator, the low temperature, low pressure refrigerant vapour enters the absorber where it comes in contact with a solution that is weak in refrigerant. The weak solution absorbs the refrigerant and becomes strong in refrigerant. The heat of absorption is rejected to the external heat sink at  $T_o$ . The solution that is now rich in refrigerant is pumped to high pressure using a solution pump and fed to the generator. In the generator heat at high temperature  $T_g$  is supplied, as a result refrigerant vapour is generated at high pressure. This high pressure vapour is then condensed in the condenser by rejecting heat of condensation to the external heat sink at  $T_o$ . The condensed refrigerant liquid is then throttled in the expansion device and is then fed to the evaporator to complete the refrigerant cycle. On the solution side, the hot, high-pressure solution that is weak in refrigerant is throttled to the absorber pressure in the solution expansion valve and fed to the absorber where it comes in contact with the refrigerant vapour from evaporator. Thus continuous refrigeration is produced at evaporator, while heat at high temperature is continuously supplied to the generator. Heat rejection to the external heat sink takes place at absorber and condenser. A small amount of mechanical energy is required to run the solution pump. If we neglect pressure drops, then the absorption system operates between the condenser and evaporator pressures. Pressure in absorber is same as the pressure in evaporator and pressure in generator is same as the pressure in condenser.

It can be seen from Fig.14.2, that as far as the condenser, expansion valve and evaporators are concerned both compression and absorption systems are identical. However, the difference lies in the way the refrigerant is compressed to condenser pressure. In vapour compression refrigeration systems the vapour is compressed mechanically using the compressor, where as in absorption system the vapour is first

converted into a liquid and then the liquid is pumped to condenser pressure using the solution pump. Since for the same pressure difference, work input required to pump a liquid (solution) is much less than the work required for compressing a vapour due to very small specific volume of liquid ( $w = - \int_{P_e}^{P_c} v \cdot dP$ ), the mechanical energy required to

operate vapour absorption refrigeration system is much less than that required to operate a compression system. However, the absorption system requires a relatively large amount of low-grade thermal energy at generator temperature to generate refrigerant vapour from the solution in generator. Thus while the energy input is in the form of mechanical energy in vapour compression refrigeration systems, it is mainly in the form of thermal energy in case of absorption systems. The solution pump work is often negligible compared to the generator heat input. Thus the COPs for compression and absorption systems are given by:

$$\text{COP}_{\text{VCRS}} = \frac{Q_e}{W_c} \quad (14.1)$$

$$\text{COP}_{\text{VARS}} = \frac{Q_e}{Q_g + W_p} \approx \frac{Q_e}{Q_g} \quad (14.2)$$

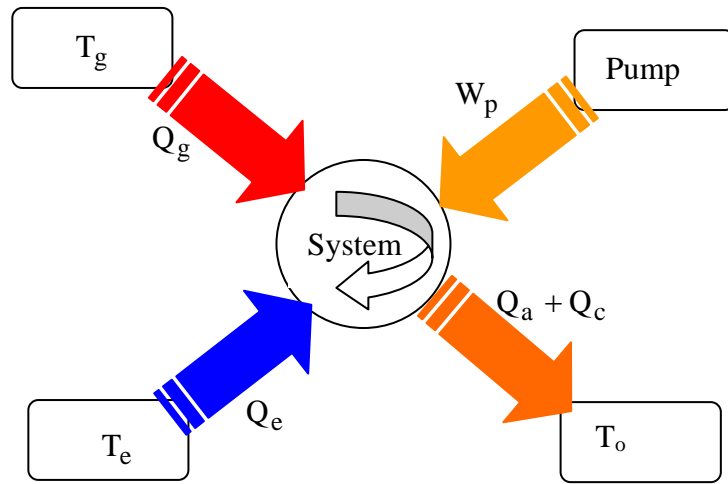
Thus absorption systems are advantageous where a large quantity of low-grade thermal energy is available freely at required temperature. However, it will be seen that for the refrigeration and heat rejection temperatures, the COP of vapour compression refrigeration system will be much higher than the COP of an absorption system as a high grade mechanical energy is used in the former, while a low-grade thermal energy is used in the latter. However, comparing these systems based on COPs is not fully justified, as mechanical energy is more expensive than thermal energy. Hence, sometimes the second law (or exergetic) efficiency is used to compare different refrigeration systems. It is seen that the second law (or exergetic) efficiency of absorption system is of the same order as that of a compression system.

### 14.3. Maximum COP of ideal absorption refrigeration system

In case of a single stage compression refrigeration system operating between constant evaporator and condenser temperatures, the maximum possible COP is given by Carnot COP:

$$\text{COP}_{\text{Carnot}} = \frac{T_e}{T_c - T_e} \quad (14.3)$$

If we assume that heat rejection at the absorber and condenser takes place at same external heat sink temperature  $T_o$ , then a vapour absorption refrigeration system operates between three temperature levels,  $T_g$ ,  $T_o$  and  $T_e$ . The maximum possible COP of a refrigeration system operating between three temperature levels can be obtained by applying first and second laws of thermodynamics to the system. Figure 14.3 shows the various energy transfers and the corresponding temperatures in an absorption refrigeration system.



**Fig.14.3:** Various energy transfers in a vapour absorption refrigeration system

From first law of thermodynamics,

$$Q_e + Q_g - Q_{c+a} + W_p = 0 \quad (14.4)$$

where  $Q_e$  is the heat transferred to the absorption system at evaporator temperature  $T_e$ ,  $Q_g$  is the heat transferred to the generator of the absorption system at temperature  $T_g$ ,  $Q_{a+c}$  is the heat transferred from the absorber and condenser of the absorption system at temperature  $T_o$  and  $W_p$  is the work input to the solution pump.

From second law of thermodynamics,

$$\Delta S_{\text{total}} = \Delta S_{\text{sys}} + \Delta S_{\text{surr}} \geq 0 \quad (14.5)$$

where  $\Delta S_{\text{total}}$  is the total entropy change which is equal to the sum of entropy change of the system  $\Delta S_{\text{sys}}$  and entropy change of the surroundings  $\Delta S_{\text{surr}}$ . Since the refrigeration system operates in a closed cycle, the entropy change of the working fluid of the system undergoing the cycle is zero, i.e.,  $\Delta S_{\text{sys}} = 0$ . The entropy change of the surroundings is given by:

$$\Delta S_{\text{surr}} = -\frac{Q_e}{T_e} - \frac{Q_g}{T_g} + \frac{Q_{a+c}}{T_o} \geq 0 \quad (14.6)$$

Substituting the expression for first law of thermodynamics in the above equation

$$Q_g \left( \frac{T_g - T_o}{T_g} \right) \geq Q_e \left( \frac{T_o - T_e}{T_e} \right) - W_p \quad (14.7)$$

Neglecting solution pump work,  $W_p$ ; the COP of VARS is given by:

$$\text{COP}_{\text{VARS}} = \frac{Q_e}{Q_g} \leq \left( \frac{T_e}{T_o - T_e} \right) \left( \frac{T_g - T_o}{T_g} \right) \quad (14.8)$$

An ideal vapour absorption refrigeration system is totally reversible (i.e., both internally and externally reversible). For a completely reversible system the total entropy change (system+surroundings) is zero according to second law, hence for an ideal VARS  $\Delta S_{\text{total,rev}} = 0 \Rightarrow \Delta S_{\text{surr,rev}} = 0$ . Hence:

$$\Delta S_{\text{surr,rev}} = -\frac{Q_e}{T_e} - \frac{Q_g}{T_g} + \frac{Q_{a+c}}{T_o} = 0 \quad (14.9)$$

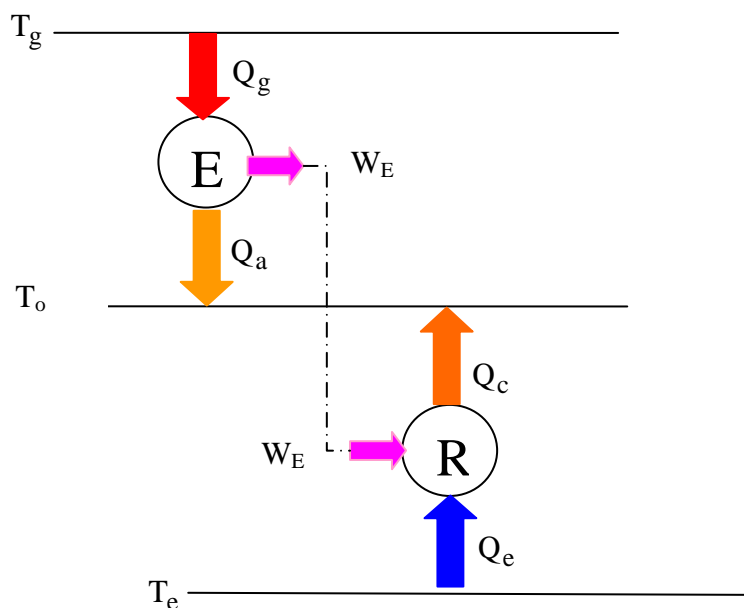
Hence combining first and second laws and neglecting pump work, the maximum possible COP of an ideal VARS system is given by:

$$\text{COP}_{\text{ideal VARS}} = \frac{Q_e}{Q_g} = \left( \frac{T_e}{T_o - T_e} \right) \left( \frac{T_g - T_o}{T_g} \right) \quad (14.10)$$

Thus the ideal COP is only a function of operating temperatures similar to Carnot system. It can be seen from the above expression that the ideal COP of VARS system is equal to the product of efficiency of a Carnot heat engine operating between  $T_g$  and  $T_o$  and COP of a Carnot refrigeration system operating between  $T_o$  and  $T_e$ , i.e.,

$$\text{COP}_{\text{ideal VARS}} = \frac{Q_e}{Q_g} = \left( \frac{T_e}{T_o - T_e} \right) \left( \frac{T_g - T_o}{T_g} \right) = \text{COP}_{\text{Carnot}} \cdot \eta_{\text{Carnot}} \quad (14.11)$$

Thus an ideal vapour absorption refrigeration system can be considered to be a combined system consisting of a Carnot heat engine and a Carnot refrigerator as shown in Fig.14.4. Thus the COP of an ideal VARS increases as generator temperature ( $T_g$ ) and evaporator temperature ( $T_e$ ) increase and heat rejection temperature ( $T_o$ ) decreases. However, the COP of actual VARS will be much less than that of an ideal VARS due to various internal and external irreversibilities present in actual systems.



**Fig.14.4:** Vapour absorption refrigeration system as a combination of a heat engine and a refrigerator

## 14.4. Properties of refrigerant-absorbent mixtures

The solution used in absorption refrigeration systems may be considered as a homogeneous binary mixture of refrigerant and absorbent. Depending upon the boiling point difference between refrigerant and absorbent and the operating temperatures, one may encounter a pure refrigerant vapour or a mixture of refrigerant and absorbent vapour in generator of the absorption system. Unlike pure substances, the thermodynamic state of a binary mixture (in liquid or vapour phase) cannot be fixed by pressure and temperature alone. According to Gibbs' phase rule, one more parameter in addition to temperature and pressure is required to completely fix the thermodynamic state. Generally, the composition of the mixture is taken as the third independent parameter. The composition of a mixture can be expressed either in mass fraction or in mole fraction. The mass fraction of components 1 and 2 in a binary mixture are given by:

$$\xi_1 = \frac{m_1}{m_1 + m_2}; \quad \xi_2 = \frac{m_2}{m_1 + m_2} \quad (14.12)$$

where  $m_1$  and  $m_2$  are the mass of components 1 and 2, respectively

The mole fraction of components 1 and 2 in a binary mixture are given by:

$$x_1 = \frac{n_1}{n_1 + n_2}; \quad x_2 = \frac{n_2}{n_1 + n_2} \quad (14.13)$$

where  $n_1$  and  $n_2$  are the number of moles of components 1 and 2, respectively

An important property of a mixture is its miscibility. A mixture is said to be completely miscible if a homogeneous mixture can be formed through any arbitrary range of concentration values. Miscibility of mixtures is influenced by the temperature at which they are mixed. Some mixtures are miscible under certain conditions and immiscible at other conditions. The refrigerant-absorbent mixtures used in absorption refrigeration systems must be completely miscible under all conditions both in liquid and vapour phases.

### 14.4.1. Ideal, homogeneous binary mixtures

A binary mixture of components 1 and 2 is called as an ideal mixture, when it satisfies the following conditions.

Condition 1: The volume of the mixture is equal to the sum of the volumes of its constituents, i.e., upon mixing there is neither contraction nor expansion. Thus the specific volume of the mixture,  $v$  is given by:

$$v = \xi_1 \cdot v_1 + \xi_2 \cdot v_2 \quad (14.14)$$

where  $\xi_1$  and  $\xi_2$  are the mass fractions of components 1 and 2. For a binary mixture,  $\xi_1$  and  $\xi_2$  are related by:

$$\xi_1 + \xi_2 = 1 \Rightarrow \xi_2 = 1 - \xi_1 \quad (14.15)$$

Condition 2: Neither heat is generated nor absorbed upon mixing, i.e., the heat of solution is zero. Then the specific enthalpy of the mixture,  $h$  is given by:

$$h = \xi_1 \cdot h_1 + \xi_2 \cdot h_2 = \xi_1 \cdot h_1 + (1 - \xi_1) h_2 \quad (14.16)$$

Condition 3: The mixture obeys Raoult's law in liquid phase, i.e., the vapour pressure exerted by components 1 and 2 ( $P_{v,1}$  and  $P_{v,2}$ ) at a temperature  $T$  are given by:

$$P_{v,1} = x_1 \cdot P_{1,sat} \quad (14.17)$$

$$P_{v,2} = x_2 \cdot P_{2,sat} \quad (14.18)$$

where  $x_1$  and  $x_2$  are the mole fractions of components 1 and 2 in solution, and  $P_{1,sat}$  and  $P_{2,sat}$  are the saturation pressures of pure components 1 and 2 at temperature  $T$ . The mole fractions  $x_1$  and  $x_2$  are related by:

$$x_1 + x_2 = 1 \Rightarrow x_2 = 1 - x_1 \quad (14.19)$$

Condition 4: The mixture obeys Dalton's law in vapour phase; i.e., the vapour pressure exerted by components 1 and 2 ( $P_{v,1}$  and  $P_{v,2}$ ) in vapour phase at a temperature  $T$  are given by:

$$P_{v,1} = y_1 \cdot P_{total} \quad (14.20)$$

$$P_{v,2} = y_2 \cdot P_{total} \quad (14.21)$$

where  $y_1$  and  $y_2$  are the vapour phase mole fractions of components 1 and 2 and  $P_{total}$  is the total pressure exerted at temperature  $T$ . The vapour phase mole fractions  $y_1$  and  $y_2$  are related by:

$$y_1 + y_2 = 1 \Rightarrow y_2 = 1 - y_1 \quad (14.22)$$

and the total pressure  $P_{total}$  is given by:

$$P_{total} = P_{v,1} + P_{v,2} \quad (14.23)$$

If one of the components, say component 2 is non-volatile compared to component 1 (e.g. component 1 is water and component 2 is lithium bromide salt), then  $y_1 \approx 1$  and  $y_2 \approx 0$ ,  $P_{v,2} \approx 0$ , then from Raoult's and Dalton's laws:

$$P_{total} \approx P_{v,1} = x_1 \cdot P_{1,sat} \quad (14.24)$$

#### 14.4.2. Real mixtures

Real mixtures deviate from ideal mixtures since:

1. A real solution either contracts or expands upon mixing, i.e.,

$$v \neq \xi_1 \cdot v_1 + \xi_2 \cdot v_2 \quad (14.25)$$

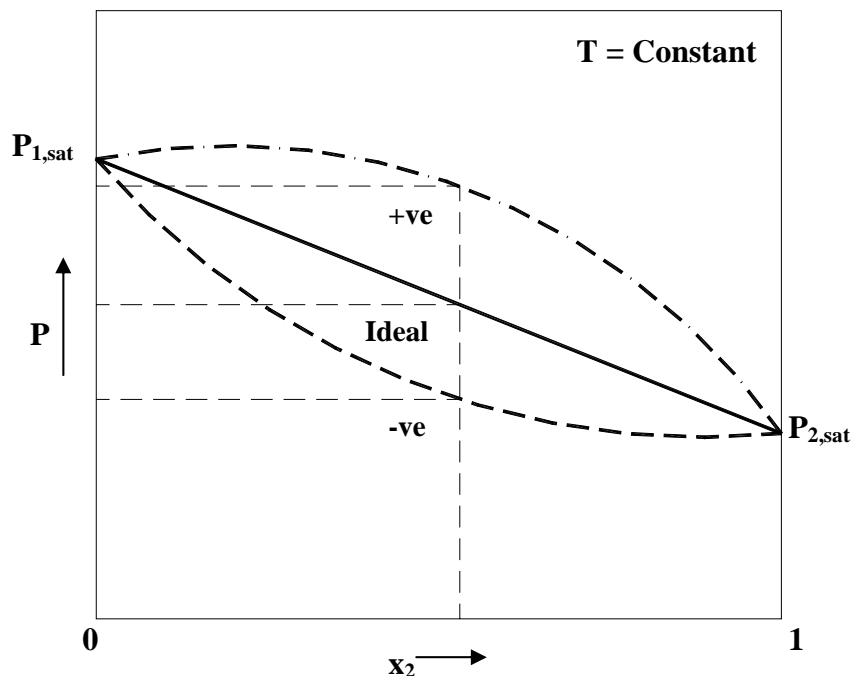


2. Either heat is evolved (exothermic) or heat is absorbed upon mixing;

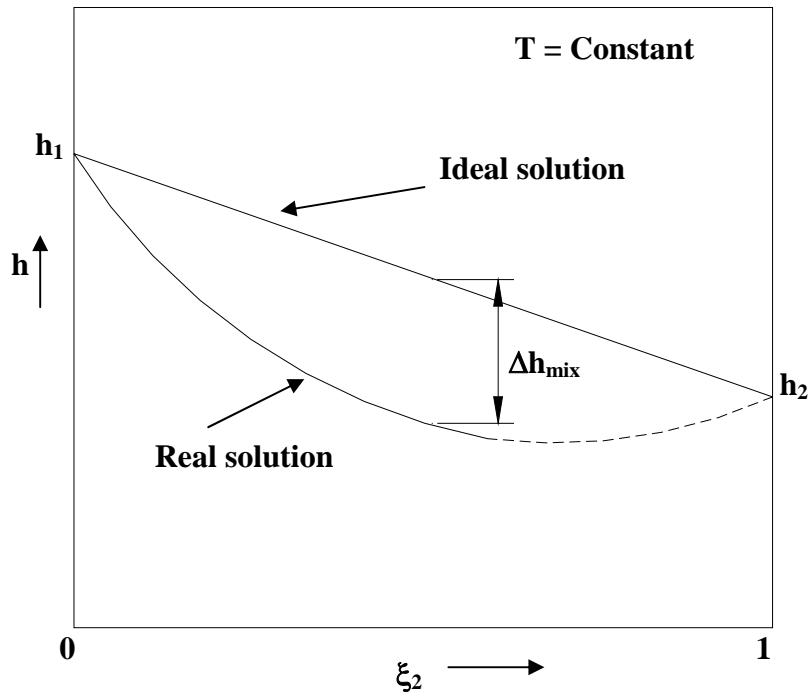
$$h = \xi_1 \cdot h_1 + (1 - \xi_1) h_2 + \Delta h_{\text{mix}} \quad (14.26)$$

where  $\Delta h_{\text{mix}}$  is the heat of mixing, which is taken as negative when heat is evolved and positive when heat is absorbed.

The above two differences between ideal and real mixtures can be attributed to the deviation of real mixtures from Raoult's law. Real mixtures approach ideal mixtures as the mole fraction of the component contributing to vapour pressure approaches unity, i.e., for very dilute solutions. Figure 14.5 shows the equilibrium pressure variation with liquid phase mole fraction ( $x$ ) of ideal and real binary mixtures with positive (+ve) and negative (-ve) deviations from Raoult's law at a constant temperature. It can be seen that when the deviation from Raoult's law is positive (+ve), the equilibrium vapour pressure will be higher than that predicted by Raoult's law, consequently at a given pressure and composition, the equilibrium temperature of solution will be lower than that predicted by Raoult's law. The converse is true for solutions with -ve deviation from Raoult's law, i.e., the equilibrium temperature at a given pressure and composition will be higher than that predicted by Raoult's law for solution with negative deviation. This behaviour can also be shown on specific enthalpy-composition diagram as shown in Fig. 14.6 for a solution with negative deviation from Raoult's law. Refrigerant-absorbent mixtures used in vapour absorption refrigeration systems exhibit a negative deviation from Raoult's law, i.e., the process of absorption is exothermic with a negative heat of mixing.



*Fig.14.5: Pressure-concentration behaviour of ideal and real mixtures at a constant temperature*

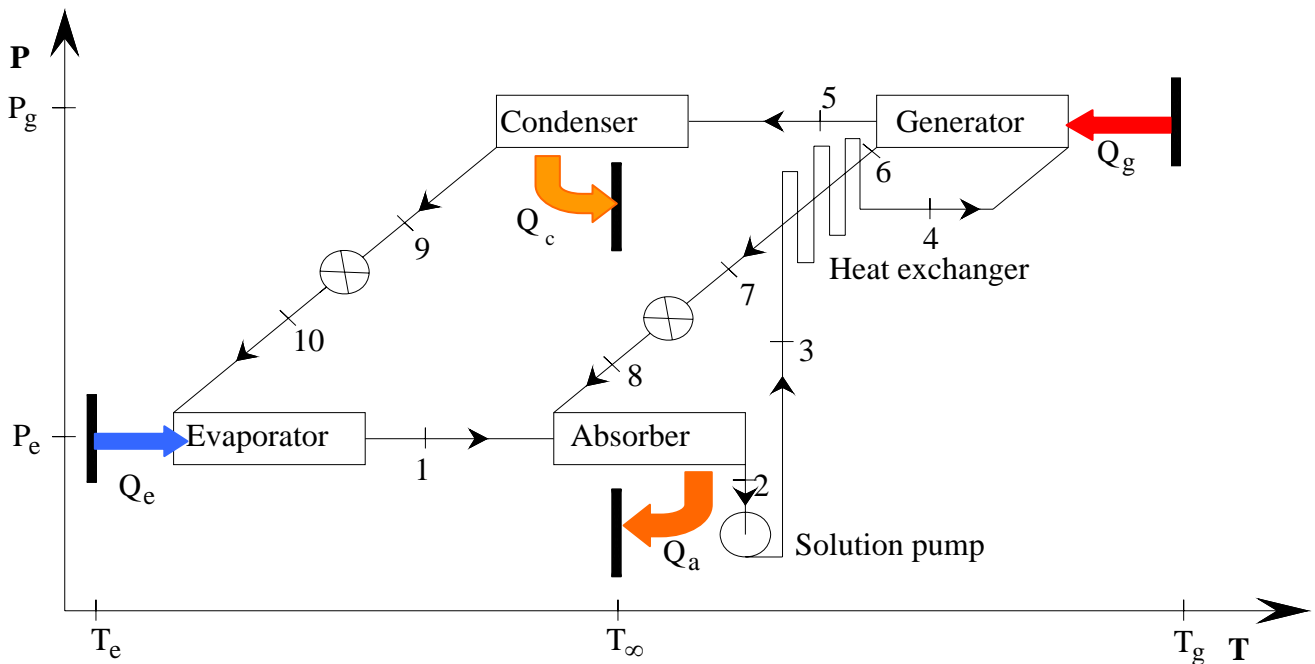


**Fig.14.6:** Enthalpy-concentration behaviour of an ideal mixture and a real mixture with negative deviation from Raoult's law

## 14.5. Basic Vapour Absorption Refrigeration System

Figure 14.7 shows a basic vapour absorption refrigeration system with a solution heat exchanger on a pressure vs temperature diagram. As shown in the figure, low temperature and low pressure refrigerant vapour from evaporator at state 1 enters the absorber and is absorbed by solution weak in refrigerant (state 8). The heat of absorption ( $Q_a$ ) is rejected to an external heat sink at  $T_\infty$ . The solution, rich in refrigerant (state 2) is pumped to the generator pressure ( $P_g$ ) by the solution pump (state 3). The pressurized solution gets heated up sensibly as it flows through the solution heat exchanger by extracting heat from hot solution coming from generator (state 4). Heat is supplied to this solution from an external heat source in the generator ( $Q_g$  at  $T_g$ ), as a result refrigerant vapour is generated (absorbent may also boil to give off vapour in case of ammonia-water systems) at state 5. This high-pressure refrigerant vapour condenses in the condenser by rejecting heat of condensation to the external heat sink ( $Q_c$  at  $T_\infty$ ) and leaves the condenser as a high pressure liquid (state 9). This high pressure refrigerant liquid is throttled in the expansion device to evaporator pressure  $P_e$  (state 10) from where it enters the evaporator, extracts heat from low temperature heat source ( $Q_e$  at  $T_e$ ) and leaves the evaporator as vapour at state 1, completing a cycle. The hot solution that is weak in refrigerant (state 6) leaves the generator at high temperature and is cooled sensibly by rejecting heat to the solution going to the generator in the solution heat exchanger (state 7). Then it is throttled to the evaporator pressure in the throttle valve (state 8), from where it enters the absorber to complete the cycle. It can be seen that though not an essential component, the solution heat exchanger is used in practical systems to improve the COP by reducing the heat input in the generator. A solution heat exchanger as shown in Fig.14.7 is a counterflow heat exchanger in which the hot solution coming from the generator comes in thermal contact with the cold solution going to the generator. As a

result of this heat exchange, less heat input is required in the generator and less heat is rejected in the absorber, thus improving the system performance significantly.



*Fig.14.7: Basic vapour absorption refrigeration system with a solution heat exchanger on a pressure vs temperature diagram*

The thermodynamic performance of the above system can be evaluated by applying mass and energy balance to each component assuming a steady flow process. In simple theoretical analyses, internal irreversibilities such as pressure drops between the components are generally neglected. To find the performance from the mass and energy balance equations one needs to know inputs such as the type of refrigerant-absorbent mixtures used in the system, operating temperatures, composition of solution at the entry and exit of absorber, effectiveness of solution heat exchanger etc. A simple steady flow analysis of the system will be presented in later sections.

## 14.6. Refrigerant-absorbent combinations for VARS

The desirable properties of refrigerant-absorbent mixtures for VARS are:

- i. The refrigerant should exhibit high solubility with solution in the absorber. This is to say that it should exhibit negative deviation from Raoult's law at absorber.
- ii. There should be large difference in the boiling points of refrigerant and absorbent (greater than 200°C), so that only refrigerant is boiled-off in the generator. This ensures that only pure refrigerant circulates through refrigerant circuit (condenser-expansion valve-evaporator) leading to isothermal heat transfer in evaporator and condenser.

- iii. It should exhibit small heat of mixing so that a high COP can be achieved. However, this requirement contradicts the first requirement. Hence, in practice a trade-off is required between solubility and heat of mixing.
- iv. The refrigerant-absorbent mixture should have high thermal conductivity and low viscosity for high performance.
- v. It should not undergo crystallization or solidification inside the system.
- vi. The mixture should be safe, chemically stable, non-corrosive, inexpensive and should be available easily.

The most commonly used refrigerant-absorbent pairs in commercial systems are:

1. Water-Lithium Bromide ( $\text{H}_2\text{O-LiBr}$ ) system for above  $0^\circ\text{C}$  applications such as air conditioning. Here water is the refrigerant and lithium bromide is the absorbent.
2. Ammonia-Water ( $\text{NH}_3\text{-H}_2\text{O}$ ) system for refrigeration applications with ammonia as refrigerant and water as absorbent.

Of late efforts are being made to develop other refrigerant-absorbent systems using both natural and synthetic refrigerants to overcome some of the limitations of ( $\text{H}_2\text{O-LiBr}$ ) and ( $\text{NH}_3\text{-H}_2\text{O}$ ) systems.

Currently, large water-lithium bromide ( $\text{H}_2\text{O-LiBr}$ ) systems are extensively used in air conditioning applications, where as large ammonia-water ( $\text{NH}_3\text{-H}_2\text{O}$ ) systems are used in refrigeration applications, while small ammonia-water systems with a third inert gas are used in a pumpless form in small domestic refrigerators (triple fluid vapour absorption systems).

### Questions:

1. Compared to compression systems, absorption systems offer the benefits of:

- a) Higher COPs
- b) Lower refrigeration temperatures
- c) Possibility of using low-grade energy sources
- d) All of the above

**Ans.: c)**

2. Absorption of the refrigerant by the absorbent in a vapour absorption refrigeration system is accompanied by:

- a) Absorption of heat
- b) Release of heat
- c) No thermal effects
- d) Reduction in volume

**Ans. b)**

3. An absorption system consisting of only two closed vessels:

- a) Can provide continuous refrigeration
- b) Provides refrigeration intermittently
- c) Can work on solar energy alone
- d) Has no practical application

**Ans. b) and c)**

4. The conventional, continuously operating single stage vapour absorption refrigeration system:

- a) Requires only thermal energy as input
- b) Uses a thermal compressor in place of a mechanical compressor
- c) Does not require a condenser
- d) Consists of two expansion valves

**Ans. b) and d)**

5. For an ideal refrigerant-absorbent mixture:

- a) There is neither expansion nor contraction upon mixing
- b) The mixing process is exothermic
- c) The mixing process is endothermic
- d) Obeys Raoult's law in liquid phase and Dalton's law in vapour phase

**Ans. a) and d)**

6. For a refrigerant-absorbent mixture with a negative deviation from Raoult's law:

- a) The mixing process is exothermic
- b) The mixing process is endothermic
- c) The actual equilibrium temperature will be less than that predicted by Raoult's law
- d) The actual equilibrium temperature will be less more that predicted by Raoult's law

**Ans. a) and d)**

7. Refrigerant-absorbent pairs used in vapour absorption refrigeration systems should:

- a) Exhibit negative deviation from Raoult's law at absorber
- b) Exhibit positive deviation from Raoult's law at absorber
- c) Have large heat of mixing
- d) Have large boiling point difference between refrigerant and absorbent

**Ans. a) and d)**

8. Which of the following statements are true:

- a) Water-lithium bromide systems are used for refrigeration applications above 0°C only
- b) Ammonia-water systems can be used for refrigeration applications below 0°C only
- c) Small ammonia-water systems are used in domestic refrigerators
- d) Small water-lithium bromide systems are used in room air conditioners

**Ans. a) and c)**

9. The operating temperatures of a single stage vapour absorption refrigeration system are: generator: **90°C**; condenser and absorber: **40°C**; evaporator: **0°C**. The system has a refrigeration capacity of **100 kW** and the heat input to the system is **160 kW**. The solution pump work is negligible.

a) Find the COP of the system and the total heat rejection rate from the system.

b) An inventor claims that by improving the design of all the components of the system he could reduce the heat input to the system to **80 kW** while keeping the refrigeration capacity and operating temperatures same as before. Examine the validity of the claim.

**Ans.:**

a) 
$$\text{COP} = Q_e/Q_g = 100/160 = \mathbf{0.625} \quad (\text{Ans.})$$

$$\text{Total heat rejection rate} = Q_a + Q_c = Q_e + Q_g = 100 + 160 = \mathbf{260 \text{ kW}} \quad (\text{Ans.})$$

b) According to the inventor's claim, the  $\text{COP}_{\text{claim}}$  is given by:

$$\text{COP}_{\text{claim}} = Q_e/Q_g = 100/80 = \mathbf{1.25}$$

However, for the given temperatures, the maximum possible COP is given by:

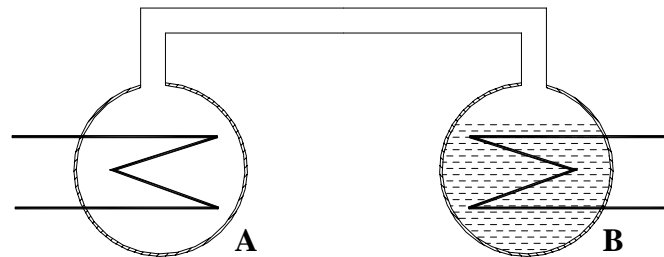
$$\text{COP}_{\text{ideal VARS}} = \left( \frac{Q_e}{Q_g} \right)_{\text{max}} = \left( \frac{T_e}{T_o - T_e} \right) \left( \frac{T_g - T_o}{T_g} \right)$$

Substituting the values of operating temperatures, we find that:

$$\text{COP}_{\text{max}} = \left( \frac{T_e}{T_o - T_e} \right) \left( \frac{T_g - T_o}{T_g} \right) = \left( \frac{273}{313 - 273} \right) \left( \frac{50}{363} \right) = \mathbf{0.94}$$

Since  $\text{COP}_{\text{claim}} > \text{COP}_{\text{max}} \Rightarrow$  **Inventor's claim is FALSE** (Ans.)

1. The following figure shows a pair of containers A & B. Container B contains an aqueous solution of (LiBr+H<sub>2</sub>O) at a mass fraction (x<sub>i</sub>) of 0.6. Container A and connecting pipe are filled with pure water vapor. Initially the system (A+B) is at an equilibrium temperature of 90°C, at which the pressure is found to be 9.0 kPa. Now water vapour starts condensing in A as cooling water starts flowing through the coil kept in A.



- What is the temperature of the coil at which steam starts condensing in A?
- Does the System pressure remain constant during condensation? If not, how to maintain the pressure constant at 9.0 kPa? What happens to the temperature of solution in B?
- As water vapour condenses in A there will be transfer of water vapour from B to A resulting in change of mass fraction of solution ( $\Delta x$ ) in B. Find a relation between  $\Delta x$  and  $f$ , where  $f$  is the ratio of initial mass of solution in B to the mass of water vapour transferred from B to A.
- What is the amount of solution required initially in B so that a mass of 1 kg of water is transferred from B to A with a corresponding change of mass fraction( $\Delta x$ ) by 0.05?
- Neglecting the contribution of temperature changes, what is the amount of heat transferred at A and B during the transfer of 1 kg of water from B to A? Is energy balanced?
- What is required to reverse the process so that initial conditions are restored?
- Show the forward and reverse process on D - ring plot.

Use the following data:

Initial enthalpy of solution = 220 kJ/kg; Final enthalpy of solution = 270 kJ/kg

Assume that the average latent heat of vaporization of water and enthalpy of water vapour = 2500 kJ/kg

Saturation pressure of water vapour (in kPa) is given by the Antoine's equation:

$$\ln(p_{\text{sat}}) = c_0 - \frac{c_1}{T + c_2}; \text{ where } T \text{ is temperature in K, } c_0=16.54, c_1=3985, c_2=-39.0$$

**Ans.:**

a) Steam in vessel A starts condensing when the surface temperature of the coil falls below the saturation temperature of water at 9.0 kPa. Using Antoine's equation:

$$\ln(9) = 16.54 - \frac{3985}{T - 39} \Rightarrow T = 316.84 \text{ K} = 43.7^\circ \text{C} \quad (\text{Ans.})$$

b) System **pressure falls** as condensation of water vapour takes place in A. To keep the system pressure constant, vapour has to be generated in B by **supplying heat to solution in B**. Since the solution in B becomes richer in LiBr (i.e., concentration increases), at the same pressure of 9.0 kPa, the **solution temperature in B increases**.  
(Ans.)

c) From the definition of concentration for H<sub>2</sub>O-LiBr solution;

$$\Delta x = x_f - x_i = \left( \frac{M_L}{M_L + M_{W,f}} \right) - \left( \frac{M_L}{M_L + M_{W,i}} \right) = M_L \left[ \frac{(M_{W,i} - M_{W,f})}{(M_L + M_{W,i})(M_L + M_{W,i})} \right]$$

Amount of water transferred from B to A =  $(M_{W,i} - M_{W,f})$

The factor f is defined as:

$$f = \left( \frac{M_L + M_{W,i}}{M_{W,i} - M_{W,f}} \right)$$

Substituting the above in the expression for  $\Delta x$  and using the definition of concentration, we find that:

$$\Delta x = x_f - x_i = \left( \frac{x_f}{f} \right) \quad (\text{Ans.})$$

d) Mass of water transferred is 1.0 kg and change in concentration is 0.05. Hence the final concentration is:

$$x_f = x_i + 0.05 = 0.60 + 0.05 = 0.65$$

Substituting this value in the expression for  $\Delta x$ , we find that

$$f = \left( \frac{x_f}{\Delta x} \right) = \left( \frac{0.65}{0.05} \right) = 13$$

Hence the initial mass of solution is given by:

$$(M_L + M_{W,i}) = f \cdot (\text{mass of water transferred}) = 13 \times 1.0 = 13 \text{ kgs} \quad (\text{Ans.})$$

e) From energy balance of vessel B, the amount of energy transferred to B is given by:

$$Q_{B,in} = (M_{B,f} \cdot h_f - M_{B,i} \cdot h_i) + (M_{W,i} - M_{W,f}) h_w$$

Substituting the values of enthalpies and initial and final mass of solution (13 kg and 12 kg, respectively), we find that the heat transferred to B is:



$$Q_{B,in} = 2880 \text{ kJ} \quad (\text{Ans.})$$

Neglecting the heat transferred during initial sensible cooling of vapour, the total heat transferred at Vessel A is:

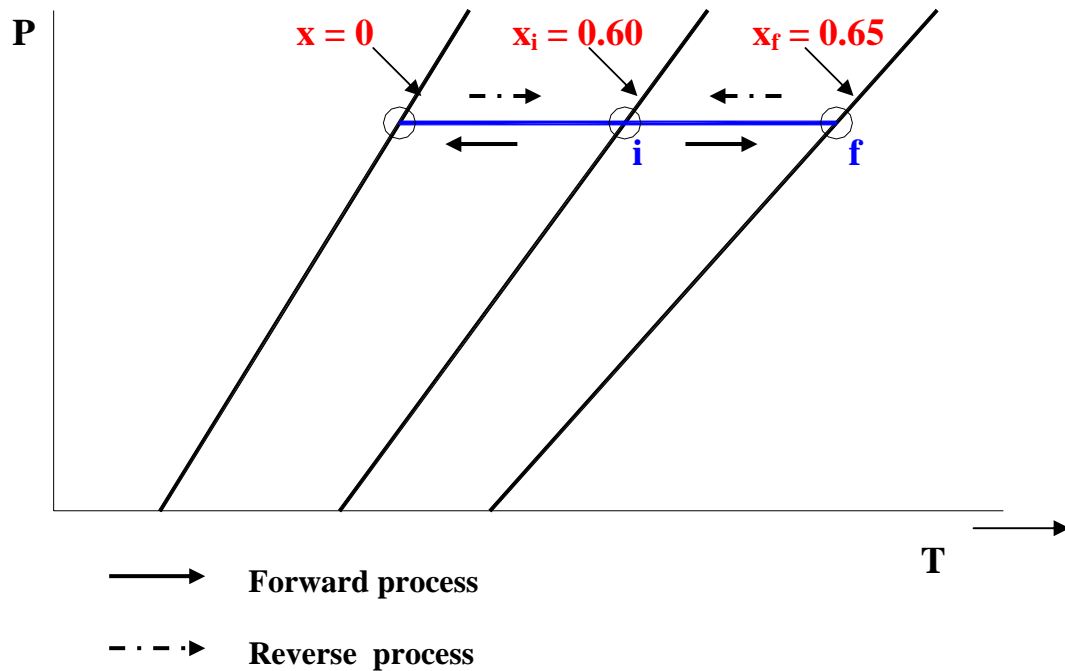
$$Q_{A,out} = \text{Amount of water vapour condensed} \times \text{latent heat of vapourization} = 2500 \text{ kJ}$$

(Ans.)

The difference in energy transferred at A and B is stored in the form of heat of solution. (Ans.)

f) To reverse the process and arrive at initial condition, the condensed water in vessel A has to be vapourized by supplying heat to vessel A. The vapour generated is absorbed by strong solution in B. Since this is an exothermic process, heat has to be rejected from B. (Ans.)

g) Dühring plot of forward and reverse processes is shown below:



# Lesson

15

## Vapour Absorption Refrigeration Systems Based On Water- Lithium Bromide Pair

## The objectives of this lesson are to:

1. Introduce vapour absorption refrigeration systems based on water-lithium bromide (*Section 15.1*)
2. Discuss properties of water-lithium bromide solution and describe pressure-temperature-concentration (p-T- $\xi$ ) and enthalpy-temperature-concentration (h-T- $\xi$ ) charts (*Section 15.2*)
3. Present steady-flow analysis of a single stage, water-lithium bromide system (*Section 15.3*)
4. Discuss practical problems in actual water-lithium bromide systems (*Section 15.4*)
5. Describe commercial water-lithium bromide systems (*Section 15.5*)
6. Discuss heat sources for water-lithium bromide systems (*Section 15.6*)
7. Discuss typical application data for water-lithium bromide systems (*Section 15.7*)
8. Discuss briefly the methods of capacity control in water-lithium bromide systems (*Section 15.8*)

At the end of the lecture, the student should be able to:

1. Draw the schematic of the water-lithium bromide system and explain its working principle
2. Evaluate the properties of water-lithium bromide solution using p-T- $\xi$  and h-T- $\xi$  charts
3. Evaluate the steady-state performance of a single stage water-lithium bromide system using the input data and fluid properties
4. Describe commercial water-lithium bromide systems and list practical problems in these systems
5. List typical operating temperatures and performance aspects of water-lithium bromide systems
6. Compare various capacity control methods in water-lithium bromide systems

## 15.1. Introduction

Vapour absorption refrigeration systems using water-lithium bromide pair are extensively used in large capacity air conditioning systems. In these systems water is used as refrigerant and a solution of lithium bromide in water is used as absorbent. Since water is used as refrigerant, using these systems it is not possible to provide refrigeration at sub-zero temperatures. Hence it is used only in applications requiring refrigeration at temperatures above 0°C. Hence these systems are used for air conditioning applications. The analysis of this system is relatively easy as the vapour generated in the generator is almost pure refrigerant (water), unlike ammonia-water systems where both ammonia and water vapour are generated in the generator.

## 15.2. Properties of water-lithium bromide solutions

### 15.2.1. Composition:

The composition of water-lithium bromide solutions can be expressed either in mass fraction ( $\xi$ ) or mole fraction ( $x$ ). For water-lithium bromide solutions, the mass fraction  $\xi$  is defined as the ratio of mass of anhydrous lithium bromide to the total mass of solution, i.e.,

$$\xi = \frac{m_L}{m_L + m_W} \quad (15.1)$$

where  $m_L$  and  $m_W$  are the mass of anhydrous lithium bromide and water in solution, respectively.

The composition can also be expressed in terms of mole fraction of lithium bromide as:

$$x = \frac{n_L}{n_L + n_W} \quad (15.2)$$

where  $n_L$  and  $n_W$  are the number of moles of anhydrous lithium bromide and water in solution, respectively. The number moles of lithium bromide and water can easily be obtained from their respective masses in solution and molecular weights, thus;

$$n_L = \frac{m_L}{M_L}; \text{ and } n_W = \frac{m_W}{M_W} \quad (15.3)$$

where  $M_L$  (= 86.8 kg/kmol) and  $M_W$  (= 18.0 kg/kmol) are the molecular weights of anhydrous lithium bromide and water respectively.

### 15.2.2. Vapour pressure of water-lithium bromide solutions

Applying Raoult's law, the vapour pressure of water-lithium bromide solution with the vapour pressure exerted by lithium bromide being negligibly small is given by:

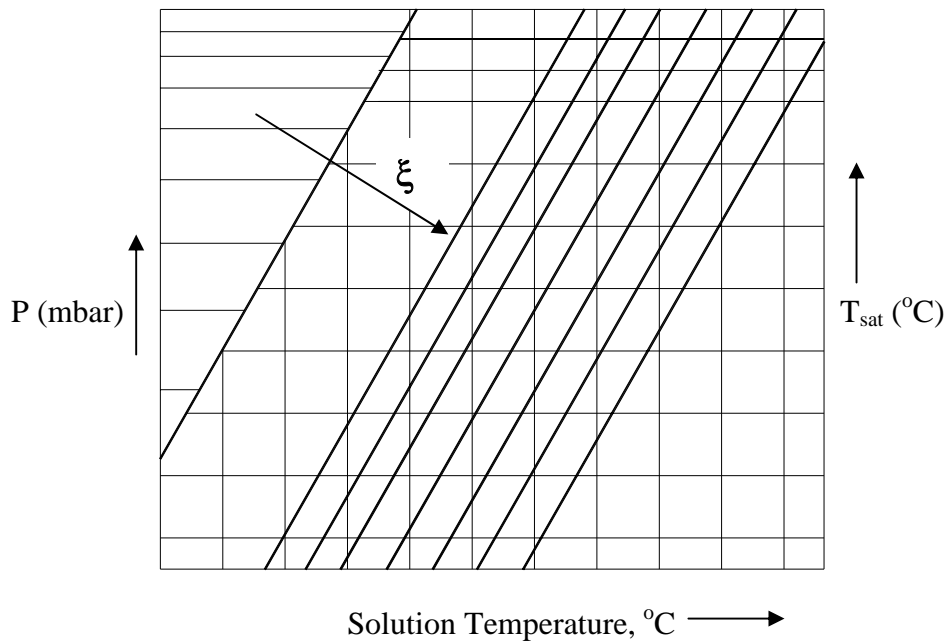
$$P = (1 - x)P_W \quad (15.4)$$

where  $P_W$  is the saturation pressure of pure water at the same temperature as that of the solution and  $x$  is the mole fraction of lithium bromide in solution. It is observed that Raoult's law is only approximately correct for very dilute solutions of water lithium bromide (i.e., as  $x \rightarrow 0$ ). Strong aqueous solutions of water-lithium bromide are found to deviate strongly from Raoult's law in a negative manner.

For example, at 50 percent mass fraction of lithium bromide and 25°C, Raoult's law predicts a vapour pressure of 26.2 mbar, whereas actual measurements show that it is only 8.5 mbar.

The ratio of actual vapour pressure to that predicted by Raoult's law is known as **activity coefficient**. For the above example, the activity coefficient is 0.324.

The vapour pressure data of water-lithium bromide solutions can be very conveniently represented in a Dühring plot. In a Dühring plot, the temperature of the solution is plotted as abscissa on a linear scale, the saturation temperature of pure water is plotted as ordinate on the right hand side (linear scale) and the pressure on a logarithmic scale is plotted as ordinate on the left hand side. The plot shows the pressure-temperature values for various constant concentration lines (isosters), which are linear on Dühring plot. Figures 15.1 shows the Dühring plot. The Dühring plot can be used for finding the vapour pressure data and also for plotting the operating cycle. Figure 15.2 shows the water-lithium bromide based absorption refrigeration system on Dühring plot. Other types of charts showing vapour pressure data for water-lithium bromide systems are also available in literature. Figure 15.3 shows another chart wherein the mass fraction of lithium bromide is plotted on abscissa, while saturation temperature of pure water and vapour pressure are plotted as ordinates. Also shown are lines of constant solution temperature on the chart. Pressure-temperature-composition data are also available in the form of empirical equations.



**Fig.15.1.:** A typical Dühring plot

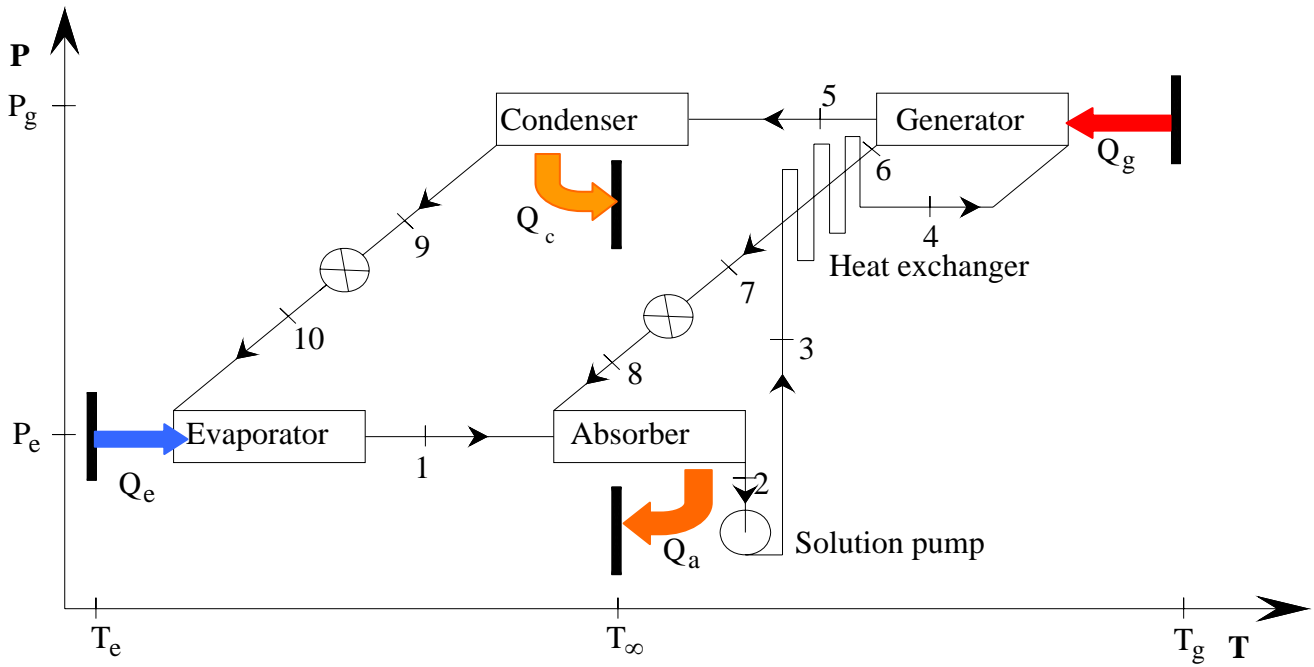


Fig.15.2: H<sub>2</sub>O-LiBr system with a solution heat exchanger on Dühring plot

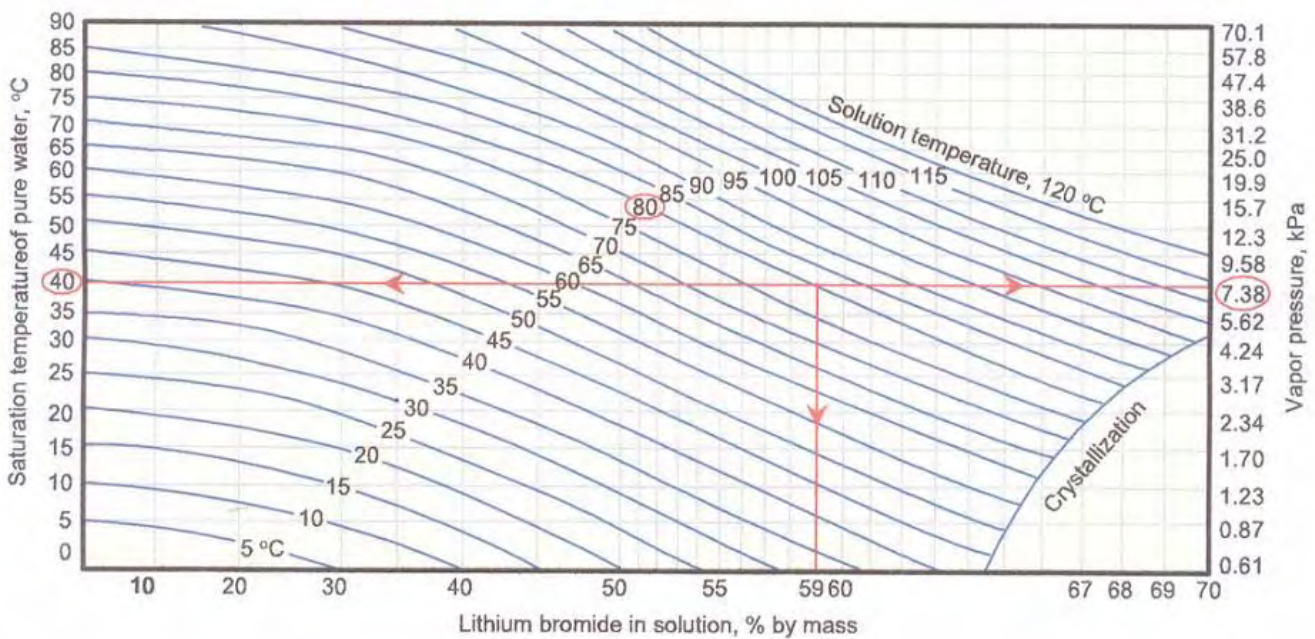


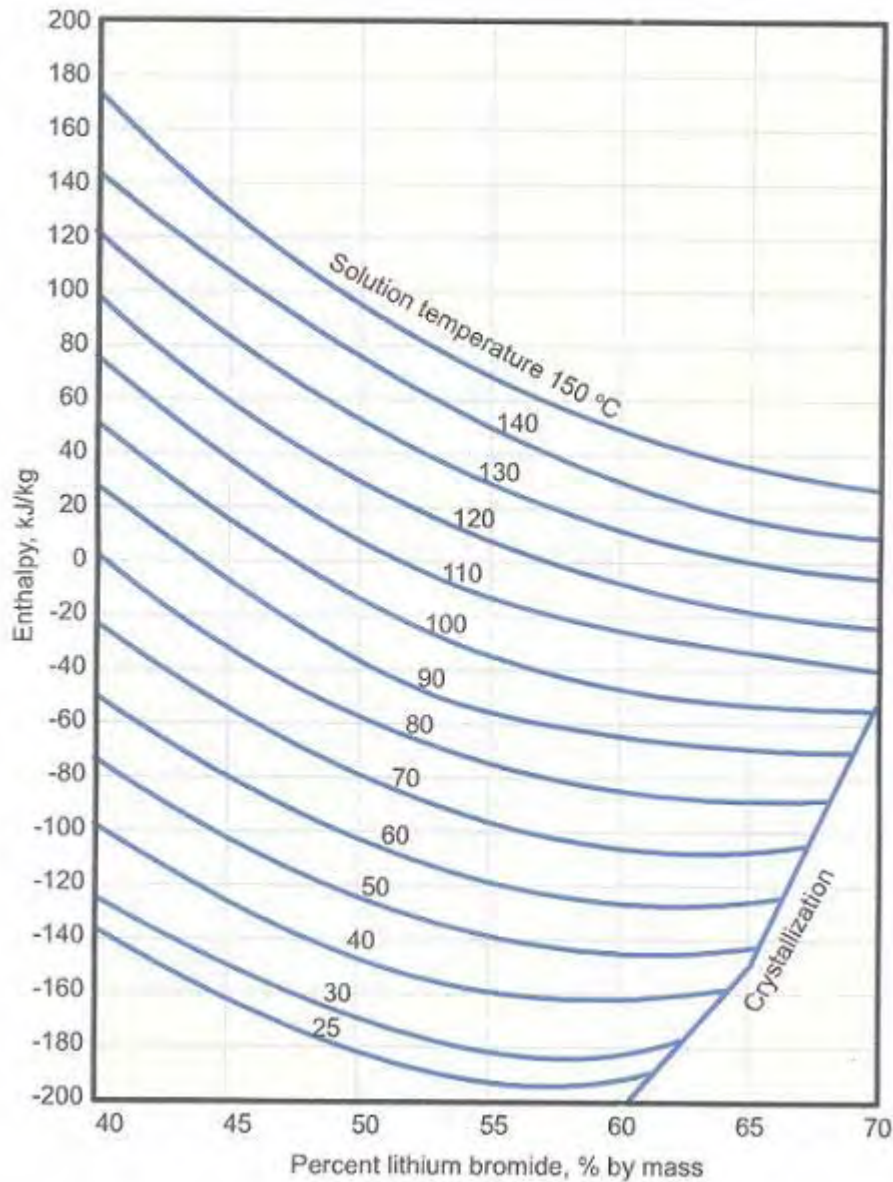
Fig.15.3: Pressure-Temperature-Concentration diagram for H<sub>2</sub>O-LiBr solution

### 15.2.3. Enthalpy of water-lithium bromide solutions

Since strong water-lithium bromide solution deviates from ideal solution behaviour, it is observed that when water and anhydrous lithium bromide at same temperature are mixed adiabatically, the temperature of the solution increases considerably. This indicates that the mixing is an exothermic process with a negative heat of mixing. Hence the specific enthalpy of the solution is given by:

$$h = \xi h_L + (1 - \xi) h_W + \Delta h_{\text{mix}} \quad (15.5)$$

where  $h_L$  and  $h_W$  are the specific enthalpies of pure lithium bromide and water, respectively at the same temperature. Figure 15.4 shows a chart giving the specific enthalpy-temperature-mass fraction data for water-lithium bromide solutions. The chart is drawn by taking reference enthalpy of 0 kJ/kg for liquid water at 0°C and solid anhydrous lithium bromide salt at 25°C.



**Fig.15.4:** Enthalpy –Temperature - Concentration diagram for  $H_2O$ -LiBr solution

#### 15.2.4. Enthalpy values for pure water (liquid and superheated vapour)

The enthalpy of pure water vapour and liquid at different temperatures and pressures can be obtained from pure water property data. For all practical purposes, liquid water enthalpy,  $h_{W,liquid}$  at any temperature  $T$  can be obtained from the equation:

$$h_{W,liquid} = 4.19(T - T_{ref}) \text{ kJ / kg} \quad (15.6)$$

where  $T_{ref}$  is the reference temperature, 0°C.

The water vapour generated in the generator of water-lithium bromide system is in super heated condition as the generator temperature is much higher than the saturation water temperature at that pressure. The enthalpy of superheated water vapour,  $h_{W,sup}$  at low pressures and temperature  $T$  can be obtained approximately by the equation:

$$h_{W,sup} = 2501 + 1.88(T - T_{ref}) \quad (15.7)$$

### 15.2.5. Crystallization

The pressure-temperature-mass fraction and enthalpy-temperature-mass fraction charts (Figs. 15.3 and 15.4) show lines marked as crystallization in the lower right section. The region to the right and below these crystallization lines indicates solidification of LiBr salt. In the crystallization region a two-phase mixture (slush) of water-lithium bromide solution and crystals of pure LiBr exist in equilibrium. The water-lithium bromide system should operate away from the crystallization region as the formation of solid crystals can block the pipes and valves. Crystallization can occur when the hot solution rich in LiBr salt is cooled in the solution heat exchanger to low temperatures. To avoid this the condenser pressure reduction below a certain value due to say, low cooling water temperature in the condenser should be avoided. Hence in commercial systems, the condenser pressure is artificially maintained high even though the temperature of the available heat sink is low. This actually reduces the performance of the system, but is necessary for proper operation of the system.

It should be noted from the property charts that the entire water-lithium bromide system operates under vacuum.

## 15.3. Steady flow analysis of Water-Lithium Bromide Systems

Figure 15.5 shows the schematic of the system indicating various state points. A steady flow analysis of the system is carried out with the following assumptions:

- i. Steady state and steady flow
- ii. Changes in potential and kinetic energies across each component are negligible
- iii. No pressure drops due to friction
- iv. Only pure refrigerant boils in the generator.

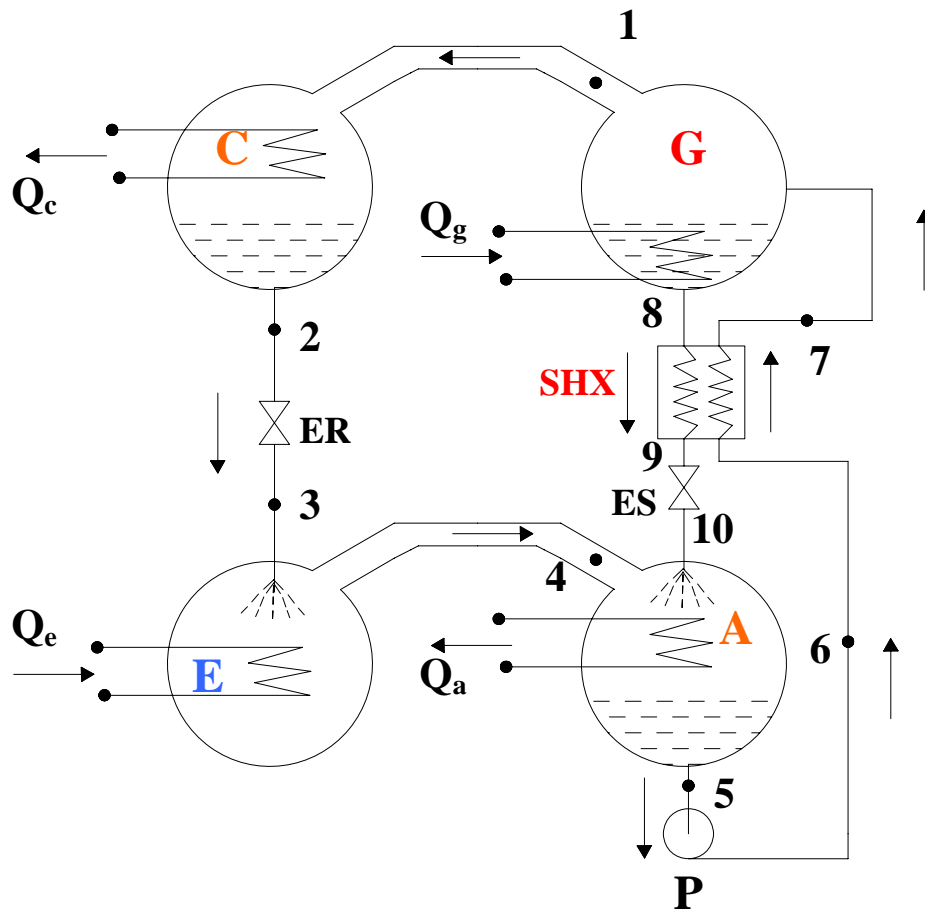
The nomenclature followed is:

$\dot{m}$  = mass flow rate of refrigerant, kg/s

$\dot{m}_{ss}$  = mass flow rate of strong solution (rich in LiBr), kg/s

$\dot{m}_{ws}$  = mass flow rate of weak solution (weak in LiBr), kg/s





**Fig.15.5:** Schematic of a H<sub>2</sub>O-LiBr system

**A:** Absorber; **C:** Condenser; **E:** Evaporator; **G:** Generator; **P:** Solution Pump  
**SHX:** Solution HX; **ER:** Refrigerant Expansion valve; **ES:** Solution Expansion valve

The circulation ratio ( $\lambda$ ) is defined as the ratio of strong solution flow rate to refrigerant flow rate. It is given by:

$$\lambda = \frac{\dot{m}_{ss}}{\dot{m}} \quad (15.7)$$

this implies that the strong solution flow rate is given by:

$$\dot{m}_{ss} = \lambda \dot{m} \quad (15.8)$$

The analysis is carried out by applying mass and energy balance across each component.

Condenser:

$$\dot{m}_1 = \dot{m}_2 = \dot{m} \quad (15.9)$$

$$Q_c = \dot{m}(h_1 - h_2) \quad (15.10)$$

$$P_c = P_{sat}(T_c) \quad (15.11)$$

where  $T_c$  is the condenser temperature

Expansion valve (refrigerant):

$$\dot{m}_2 = \dot{m}_3 = \dot{m} \quad (15.12)$$

$$h_2 = h_3 \quad (15.13)$$

Evaporator:

$$\dot{m}_3 = \dot{m}_4 = \dot{m} \quad (15.14)$$

$$Q_e = \dot{m}(h_4 - h_3) \quad (15.15)$$

$$P_e = P_{\text{sat}}(T_e) \quad (15.16)$$

where  $T_e$  is the evaporator temperature

Absorber:

From total mass balance:

$$\dot{m} + \dot{m}_{\text{ss}} = \dot{m}_{\text{ws}} \quad (15.17)$$

$$\dot{m}_{\text{ss}} = \lambda \dot{m} \Rightarrow \dot{m}_{\text{ws}} = (1 + \lambda) \dot{m}$$

From mass balance for pure water:

$$\dot{m} + (1 - \xi_{\text{ss}}) \dot{m}_{\text{ss}} = (1 - \xi_{\text{ws}}) \dot{m}_{\text{ws}} \quad (15.18)$$

$$\Rightarrow \lambda = \frac{\xi_{\text{ws}}}{\xi_{\text{ss}} - \xi_{\text{ws}}}$$

$$Q_a = \dot{m} h_4 + \lambda \dot{m} h_{10} - (1 + \lambda) \dot{m} h_5 \quad (15.19)$$

$$\text{or, } Q_a = \dot{m} [(h_4 - h_5) + \lambda(h_{10} - h_5)] \quad (15.20)$$

The first term in the above equation  $\dot{m}(h_4 - h_5)$  represents the enthalpy change of water as changes its state from vapour at state 4 to liquid at state 5. The second term  $\dot{m} \lambda(h_{10} - h_5)$  represents the sensible heat transferred as solution at state 10 is cooled to solution at state 5.

Solution pump:

$$\dot{m}_5 = \dot{m}_6 = \dot{m}_{\text{ws}} \quad (15.21)$$

$$W_p = \dot{m}_{\text{ws}} (h_6 - h_5) = (1 + \lambda) \dot{m} (h_6 - h_5) \quad (15.22)$$

however, if we assume the solution to be incompressible, then:

$$W_P = (1 + \lambda) \dot{m} v_{sol} (P_6 - P_5) = (1 + \lambda) \dot{m} v_{sol} (P_c - P_e) \quad (15.23)$$

where  $v_{sol}$  is the specific volume of the solution which can be taken to be approximately equal to  $0.00055 \text{ m}^3/\text{kg}$ . Even though the solution pump work is small it is still required in the selection of suitable pump.

Solution heat exchanger:

$$\begin{aligned} \dot{m}_6 &= \dot{m}_7 = \dot{m}_{ws} \\ \dot{m}_8 &= \dot{m}_9 = \dot{m}_{ss} \end{aligned} \quad (15.24)$$

heat transfer rate in the solution heat exchanger,  $Q_{HX}$  is given by:

$$Q_{HX} = (1 + \lambda) \dot{m} (h_7 - h_6) = \lambda \dot{m} (h_8 - h_9) \quad (15.25)$$

Generator:

$$\dot{m}_7 = \dot{m}_8 + \dot{m}_1 \quad (15.26)$$

Heat input to the generator is given by:

$$Q_g = \dot{m} h_1 + \lambda \dot{m} h_8 - (1 + \lambda) \dot{m} h_7 \quad (15.27)$$

$$\text{or, } Q_g = \dot{m} [(h_1 - h_7) + \lambda (h_8 - h_7)] \quad (15.28)$$

in the above equation the 1<sup>st</sup> term on the RHS  $\dot{m}(h_1 - h_7)$  represents energy required to generate water vapour at state 1 from solution at state 7 and the 2<sup>nd</sup> term  $\dot{m}\lambda(h_8 - h_7)$  represents the sensible heat required to heat the solution from state 7 to state 8.

Solution expansion valve:

$$\dot{m}_9 = \dot{m}_{10} = \dot{m}_{ws} \quad (15.29)$$

$$h_9 = h_{10} \quad (15.30)$$

The COP of the system is given by:

$$\text{COP} = \frac{Q_e}{Q_g + W_P} \approx \frac{Q_e}{Q_g} \quad (15.31)$$

The second law (exergetic) efficiency of the system  $\eta_{II}$  is given by:

$$\eta_{II} = \frac{\text{COP}}{\text{COP}_{\max}} = \left( \frac{Q_e}{Q_g} \right) \left( \frac{T_g}{T_g - T_c} \right) \left( \frac{T_c - T_e}{T_e} \right) \quad (15.32)$$

In order to find the steady-state performance of the system from the above set of equations, one needs to know the operating temperatures, weak and strong solution concentrations, effectiveness of solution heat exchanger and the refrigeration capacity. It is generally assumed that the solution at the exit of absorber and generator is at equilibrium so that the equilibrium P-T- $\xi$  and h-T- $\xi$  charts can be used for evaluating solution property data. The effectiveness of solution heat exchanger,  $\varepsilon_{HX}$  is given by:

$$\varepsilon_{HX} = \frac{(T_7 - T_6)}{(T_8 - T_6)} \quad (15.33)$$

From the above equation the temperature of the weak solution entering the generator ( $T_7$ ) can be obtained since  $T_6$  is almost equal to  $T_5$  and  $T_8$  is equal to the generator temperature  $T_g$ . The temperature of superheated water vapour at state 1 may be assumed to be equal to the strong solution temperature  $T_8$ .

## 15.4. Practical problems in water-lithium bromide systems

Practical problems typical to water-lithium bromide systems are:

1. Crystallization
2. Air leakage, and
3. Pressure drops

As mentioned before to prevent crystallization the condenser pressure has to be maintained at certain level, irrespective of cooling water temperature. This can be done by regulating the flow rate of cooling water to the condenser. Additives are also added in practical systems to inhibit crystallization. Since the entire system operates under vacuum, outside air leaks into the system. Hence an air purging system is used in practical systems. Normally a two-stage ejector type purging system is used to remove air from the system. Since the operating pressures are very small and specific volume of vapour is very high, pressure drops due to friction should be minimized. This is done by using twin- and single-drum arrangements in commercial systems.

## 15.5. Commercial systems

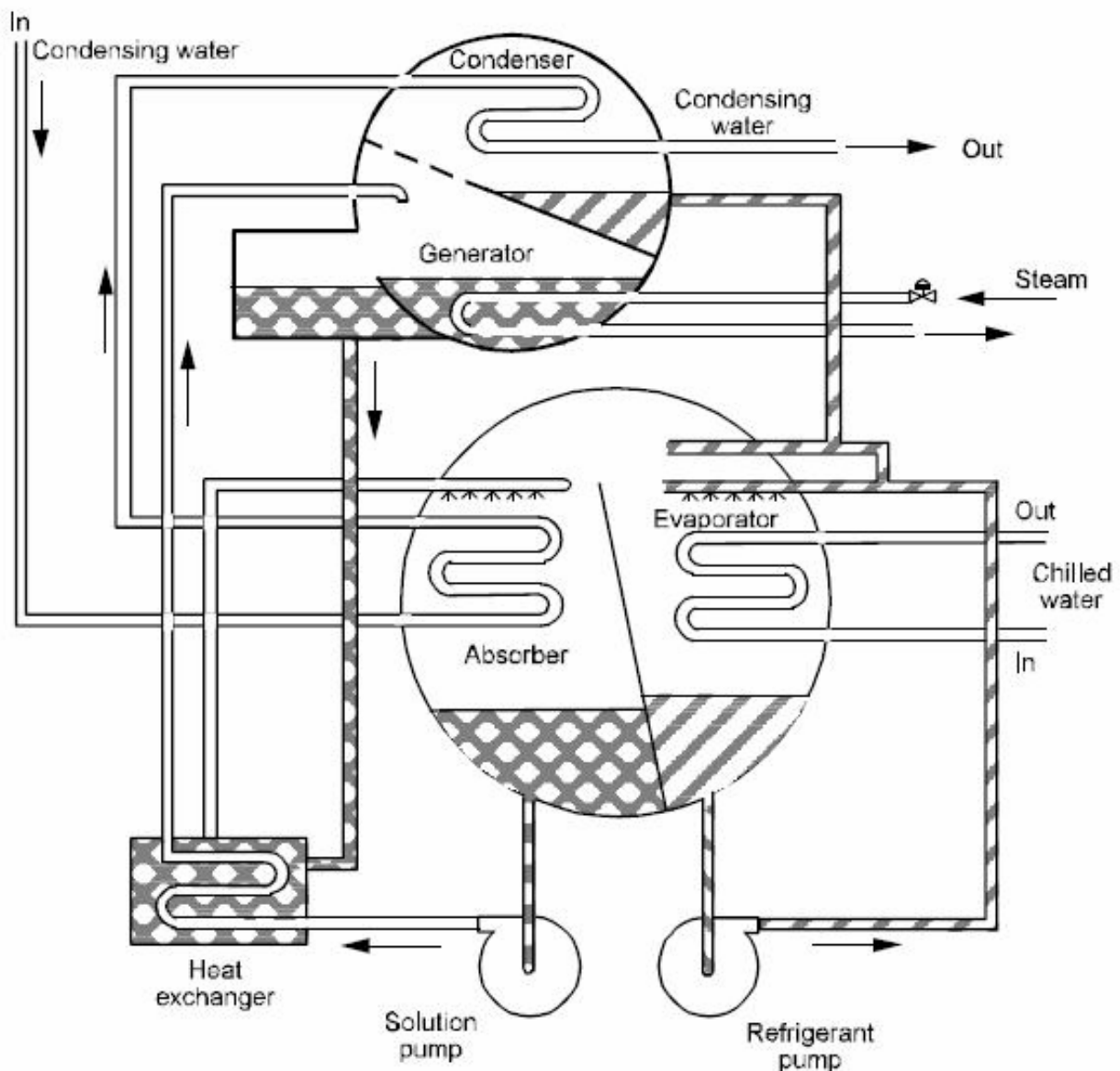
Commercial water-lithium bromide systems can be:

1. Single stage or single-effect systems, and
2. Multi stage or multi-effect systems

Single stage systems operate under two pressures – one corresponding to the condenser-generator (high pressure side) and the other corresponding to evaporator-absorber. Single stage systems can be either:

1. Twin drum type, or
2. Single drum type

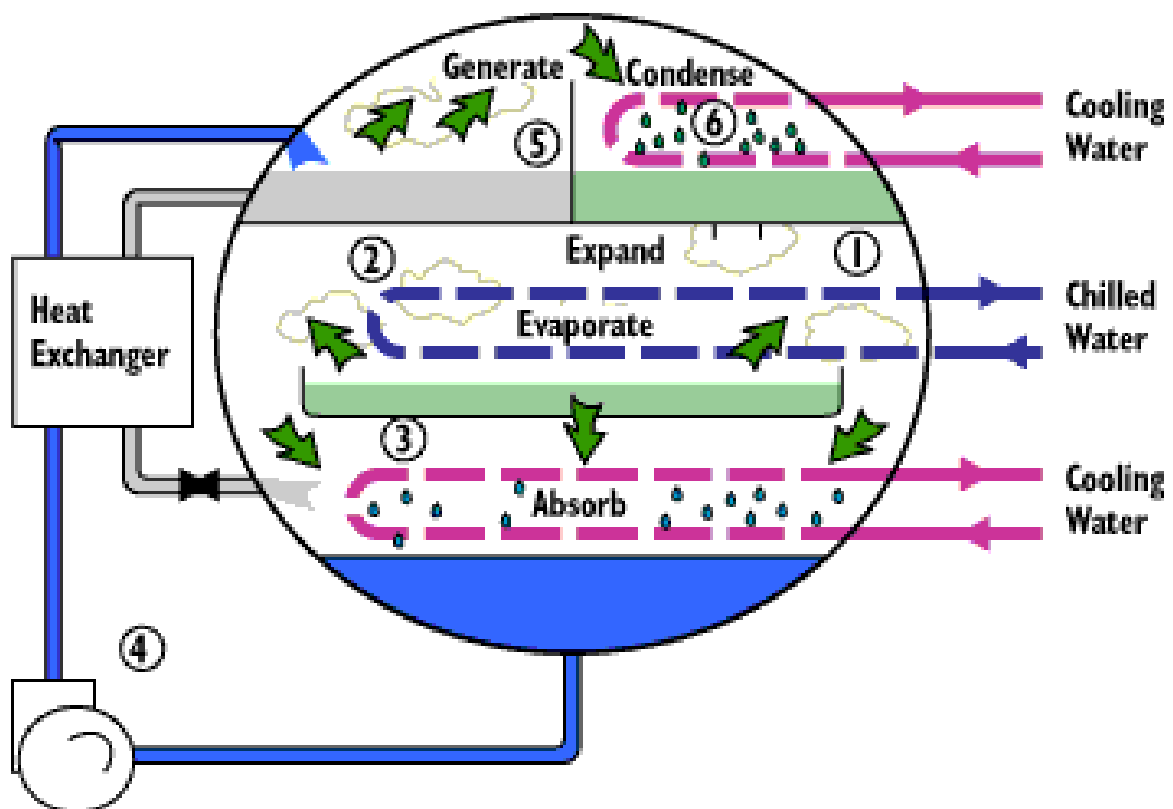
Since evaporator and absorber operate at the same pressure they can be housed in a single vessel, similarly generator and condenser can be placed in another vessel as these two components operate under a single pressure. Thus a twin drum system consists of two vessels operating at high and low pressures. Figure 15.6 shows a commercial, single stage, twin drum system.



*Fig.15.6: A commercial, twin-drum type, water-lithium bromide system*

As shown in the figure, the cooling water (which acts as heat sink) flows first to absorber, extracts heat from absorber and then flows to the condenser for condenser heat extraction. This is known as series arrangement. This arrangement is advantageous as the required cooling water flow rate will be small and also by sending the cooling water first to the absorber, the condenser can be operated at a higher pressure to prevent crystallization. It is also possible to have cooling water flowing parallelly to condenser and absorber, however, the cooling water requirement in this case will be high. A refrigerant pump circulates liquid water in evaporator and the water is sprayed onto evaporator tubes for good heat and mass transfer. Heater tubes (steam or hot water or hot oil) are immersed in the strong solution pool of generator for vapour generation. Pressure drops between evaporator and absorber and between generator and condenser are minimized, large sized vapour lines are eliminated and air leakages can also be reduced due to less number of joints.

Figure 15.7 shows a single stage system of single drum type in which all the four components are housed in the same vessel. The vessel is divided into high and low pressure sides by using a diaphragm.



*Fig.15.7: A commercial, single-drum type, water-lithium bromide system*

In multi-effect systems a series of generators operating at progressively reducing pressures are used. Heat is supplied to the highest stage generator operating at the highest pressure. The enthalpy of the steam generated from this generator is used to generate some more refrigerant vapour in the lower stage generator and so on. In this manner the heat input to the system is used efficiently by generating more refrigerant vapour leading to higher COPs. However, these systems are more complex in construction and require a much higher heat source temperatures in the highest stage generator. Figures 15.8 and 15.9 show commercial double-effect systems. Figure 15.10 shows the double effect cycle on Dühring plot.

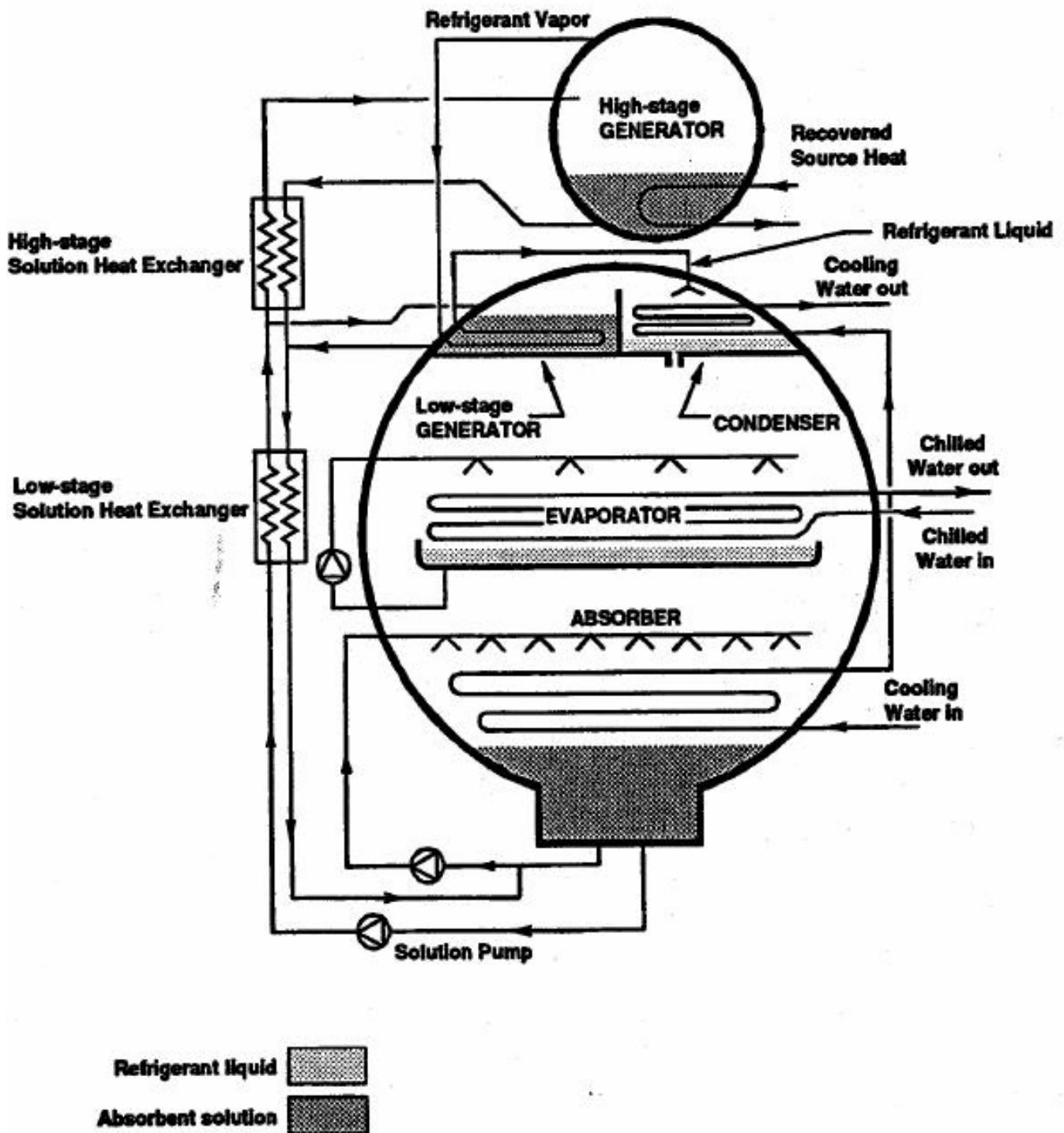
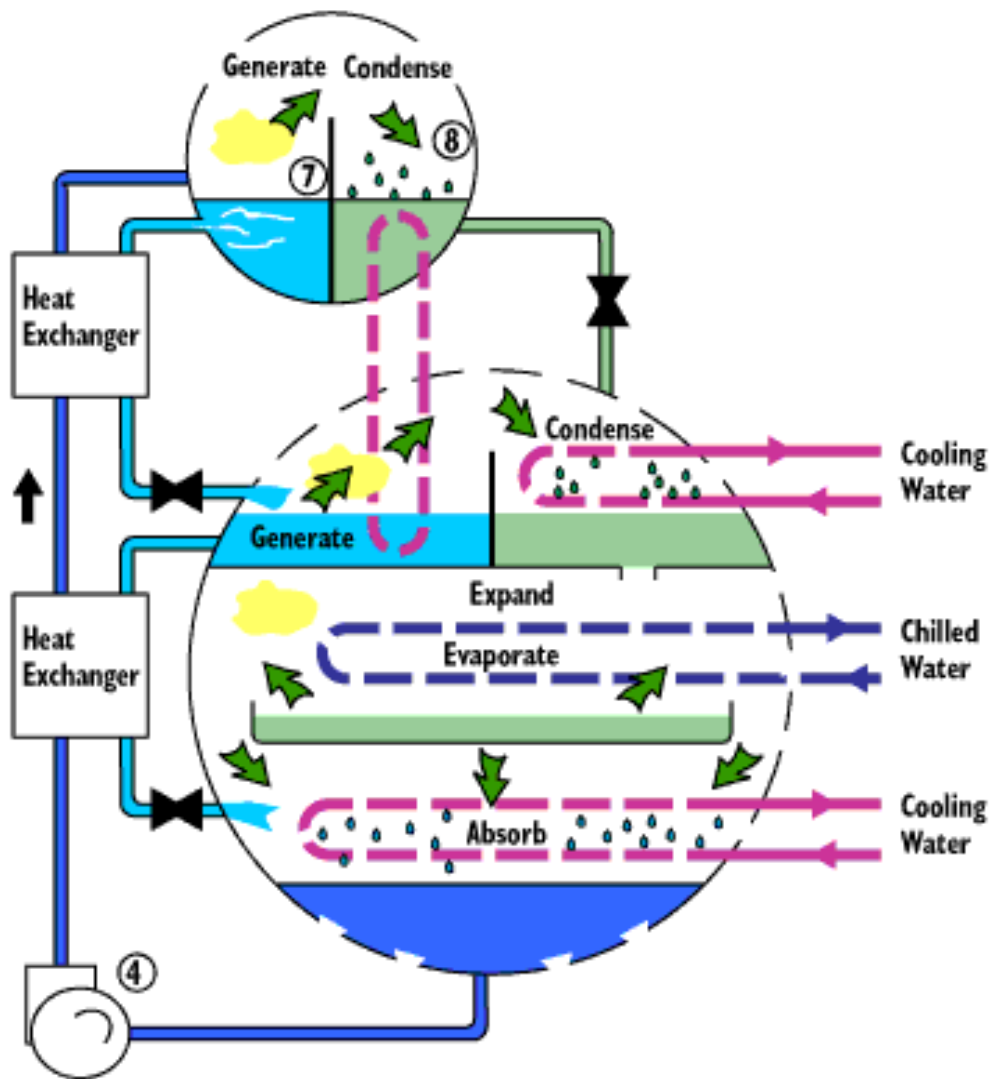
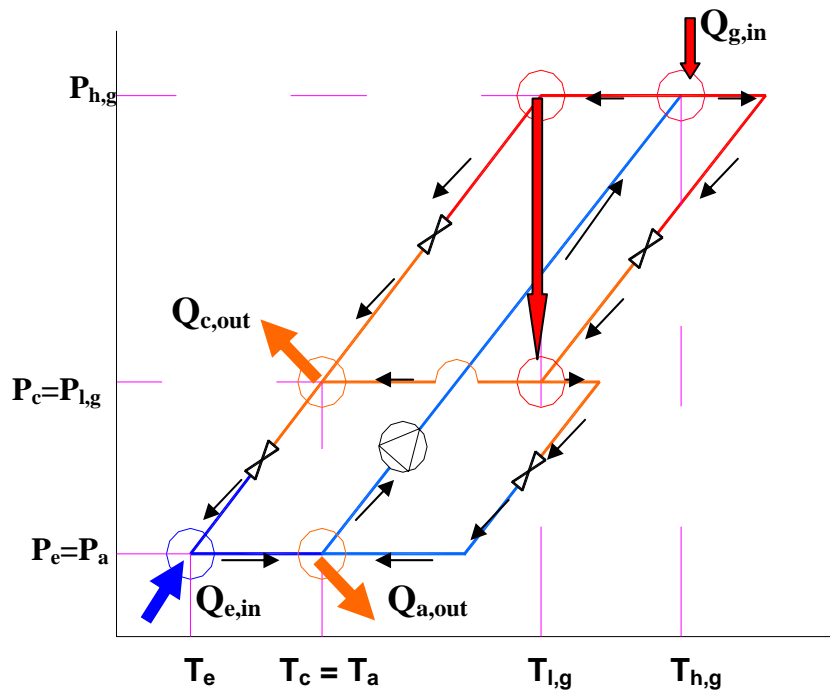


Fig.15.8: A commercial, double-effect, water-lithium bromide system



*Fig.15.9: A commercial, double-effect, water-lithium bromide system*



*Fig.15.10: Double effect VARS on Dühring plot*



## 15.6. Heat sources for water-lithium bromide systems

Water-lithium bromide systems can be driven using a wide variety of heat sources. Large capacity systems are usually driven by steam or hot water. Small capacity systems are usually driven directly by oil or gas. A typical single effect system requires a heat source at a temperature of about **120°C** to produce chilled water at **7°C** when the condenser operates at about **46°C** and the absorber operates at about **40°C**. The COPs obtained are in the range of **0.6 to 0.8** for single effect systems while it can be as high as **1.2 to 1.4** for multi-effect systems.

## 15.7. Minimum heat source temperatures for LiBr-Water systems

Application data for a single-stage water-lithium bromide vapour absorption system with an output chilled water temperature of **6.7°C** (for air conditioning applications) is shown in Table 15.1.

<b>Cooling water temperature (inlet to absorber &amp; condenser)</b>	<b>Minimum Heat source temperature (Inlet to generator)</b>	<b>COP</b>
23.9°C	65°C	0.75
26.7°C	75 °C	0.74
29.4°C	85 °C	0.72
32.2°C	95 °C	0.71

*Table 15.1. Application data for a single-stage water-lithium bromide system*

The above values are simulated values, which were validated on actual commercial systems with very efficient heat and mass transfer design. If the heat and mass transfer is not very efficient, then the actual required heat source temperatures will be higher than the reported values. For a given cooling water temperature, if the heat source temperature drops below the minimum temperature given above, then the COP drops significantly. For a given cooling water temperature, if the heat source temperature drops below a certain temperature (minimum generation temperature), then the system will not function. Minimum generation temperature is typically 10 to 15°C lower than the minimum heat source temperature. If air cooled condensers and absorbers are used, then the required minimum heat source temperatures will be much higher ( $\approx 150^\circ\text{C}$ ). The COP of the system can be increased significantly by multi-effect (or multi-stage) systems. However, addition of each stage increases the required heat source temperature by approximately 50°C.

## 15.7 Capacity control

Capacity control means capacity reduction depending upon load as the capacity will be maximum without any control. Normally under both full as well as part loads the outlet temperature of chilled water is maintained at a near constant value. The refrigeration capacity is then regulated by either:

1. Regulating the flow rate of weak solution pumped to the generator through the solution pump
2. Reducing the generator temperature by throttling the supply steam, or by reducing the flow rate of hot water
3. Increasing the condenser temperature by bypassing some of the cooling water supplied to the condenser

Method 1 does not affect the COP significantly as the required heat input reduces with reduction in weak solution flow rate, however, since this may lead to the problem of crystallization, many a time a combination of the above three methods are used in commercial systems to control the capacity.

### Questions:

1. Vapour absorption refrigeration systems using water-lithium bromide:

- a) Are used in large air conditioning systems
- b) Are used in large frozen food storage applications
- c) Operate under vacuum
- c) All of the above

**Ans. a) and c)**

2. For a required refrigeration capacity, the solution heat exchanger used in water-lithium bromide systems:

- a) Reduces the required heat input to generator
- b) Reduces the heat rejection rate at absorber
- c) Reduces heat rejection rate at condenser
- d) Reduces the required heat source temperature

**Ans. a) and b)**

3. In water-lithium bromide systems:

- a) Crystallization of solution is likely to occur in absorber
- b) Crystallization of solution is likely to occur in solution heat exchanger
- c) Crystallization is likely to occur when generator temperature falls
- d) Crystallization is likely to occur when condenser pressure falls

**Ans. a) and d)**

4. In commercial water-lithium bromide systems

- a) Crystallization is avoided by regulating cooling water flow rate to condenser
- b) Crystallization is avoided by adding additives
- c) An air purging system is used to maintain vacuum
- d) All of the above

Ans. d)

5. Commercial multi-effect absorption systems:

- a) Yield higher COPs
- b) Yield higher refrigeration temperatures
- c) Require lower heat source temperatures
- d) Require higher heat source temperatures

**Ans. a) and d)**

6. In water-lithium bromide systems:

- a) The required heat source temperature should be higher than minimum heat generation temperature
- b) The required heat source temperature decreases as cooling water temperature increases
- c) The required heat source temperature is higher for air cooled condensers, compared to water cooled condensers
- d) All of the above

**Ans. a) and c)**

7. In commercial water-lithium bromide systems, the system capacity is regulated by:

- a) Controlling the weak solution flow rate to generator
- b) Controlling the flow rate of chilled water to evaporator
- c) Controlling the temperature of heating fluid to generator
- d) All of the above

**Ans. a) and c)**

8. A single stage vapour absorption refrigeration system based on H<sub>2</sub>O-LiBr has a refrigeration capacity of 300 kW. The system operates at an evaporator temperature of 5°C ( $P_{\text{sat}}=8.72$  mbar) and a condensing temperature of 50°C ( $P_{\text{sat}}=123.3$  mbar). The exit temperatures of absorber and generator are 40°C and 110°C respectively. The concentration of solution at the exit of absorber and generator are 0.578 and 0.66, respectively. Assume 100 percent effectiveness for the solution heat exchanger, exit condition of refrigerant at evaporator and condenser to be saturated and the condition of the solution at the exit of absorber and generator to be at equilibrium. Enthalpy of strong solution at the inlet to the absorber may be obtained from the equilibrium solution data.

Find:

- a) The mass flow rates of refrigerant, weak and strong solutions
- b) Heat transfer rates at the absorber, evaporator, condenser, generator and solution heat exchanger
- c) System COP and second law efficiency, and

d) Solution pump work (density of solution = 1200 kg/m<sup>3</sup>).

**Given:**

Refrigeration capacity	:	300 kW
Evaporator temperature	:	5°C
Condenser temperature	:	50°C
Absorber temperature	:	40°C
Generator temperature	:	110°C
Weak solution concentration, $\xi_{ws}$	:	0.578
Strong solution concentration, $\xi_{ss}$	:	0.66
Effectiveness of solution HX, $\epsilon_{HX}$	:	1.0
Density of solution, $\rho_{sol}$	:	1200 kg/m <sup>3</sup>
Refrigerant exit at evaporator & condenser	:	Saturated
Solution at the exit of absorber & generator	:	Equilibrium

Referring to Fig.15.5;

Assuming the refrigerant vapour at the exit of generator to be in equilibrium with the strong solution leaving the generator

$$\Rightarrow \text{Temperature of vapour at generator exit} = \mathbf{110^\circ\text{C}}$$

$$\Rightarrow \text{enthalpy of vapour} = 2501 + 1.88 \times 110 = \mathbf{2708 \text{ kJ/kg}}$$

From the definition of effectiveness of solution HX;

$$\epsilon_{HX} = [m_{SS}C_{p,SS}(T_8 - T_9)] / [m_{SS}C_{p,SS}(T_8 - T_6)] = 1.0 \quad (\because m_{SS} < m_{WS})$$

$$\Rightarrow \mathbf{T_9 = T_6 = 40^\circ\text{C}}$$

From the above equation, the following property data at various points are obtained using refrigerant property charts and water – LiBr solution property charts

State point	Temperature (°C)	Pressure (mbar)	Mass fraction, $\xi$	Enthalpy (kJ/kg)
1	110	123.3	-	2708
2	50	123.3	-	209
3	5	8.72	-	209
4	5	8.72	-	2510
5	40	8.72	0.578	-154
6	40	123.3	0.578	-154
7	-	123.3	0.578	-37.5
8	110	123.3	0.66	-13
9	40	123.3	0.66	-146
10	40	8.72	0.66	-146

The enthalpy of superheated water vapour ( $h_v$ ) may be obtained by using the equation:

$$h_v = 2501 + 1.88 t, \text{ where } h_v \text{ is in kJ/kg and } t \text{ is in } ^\circ\text{C}.$$

Enthalpy of weak solution at the exit of solution HX is obtained from the energy balance equation:  $m_{WS}(h_7-h_6) = m_{SS}(h_8-h_9) \Rightarrow h_7 = h_6 + m_{SS}(h_8-h_9)/m_{WS} = -37.5 \text{ kJ/kg}$

a) Required mass flow rate of refrigerant,  $m = Q_e/(h_4-h_3) = 0.1304 \text{ kg/s}$  (Ans.)

$$\text{Circulation ratio, } \lambda = m_{SS}/m = \xi_{WS}/(\xi_{SS}-\xi_{WS}) = 7.05$$

$\therefore$  mass flow rate of strong solution,  $m_{SS} = \lambda m = 0.9193 \text{ kg/s}$  (Ans.)

mass flow rate of weak solution,  $m_{WS} = (\lambda+1)m = 1.05 \text{ kg/s}$  (Ans.)

b) Heat transfer rates at various components:

Evaporator:  $Q_e = 300 \text{ kW}$  (input data)

Absorber: From energy balance:

$$Q_a = m h_4 + m_{SS} h_{10} - m_{WS} h_5 = 354.74 \text{ kW} \quad (\text{Ans.})$$

Generator: From energy balance:

$$Q_g = m h_1 + m_{ss} h_8 - m_w h_7 = 380.54 \text{ kW} \quad (\text{Ans.})$$

Condenser: From energy balance:

$$Q_c = m(h_1 - h_2) = 325.9 \text{ kW} \quad (\text{Ans.})$$

Solution heat exchanger: From energy balance:

$$Q_{SHX} = m\lambda(h_8 - h_9) = m(\lambda + 1)(h_7 - h_6) = 122.3 \text{ kW} \quad (\text{Ans.})$$

c) System COP (neglecting pump work) =  $Q_e/Q_g = 0.7884$  (Ans.)

$$\text{Second law efficiency} = \text{COP}/\text{COP}_{\text{Carnot}}$$

$$\text{COP}_{\text{Carnot}} = [T_e/(T_c - T_e)][(T_g - T_a)/T_g] = 1.129$$

$$\therefore \text{Second law efficiency} = 0.6983 \quad (\text{Ans.})$$

d) Solution pump work (assuming the solution to be incompressible)

$$W_P = v_{\text{sol}}(P_6 - P_5) = (P_6 - P_5)/\rho_{\text{sol}} = (123.3 - 8.72) \times 10^{-1} / 1200 = 0.0095 \text{ kW} \quad (\text{Ans.})$$

# Lesson

16

## Vapour Absorption Refrigeration Systems Based On Ammonia- Water Pair

## The specific objectives of this lesson are to:

1. Introduce ammonia-water based vapour absorption refrigeration systems (*Section 16.1*)
2. Discuss the properties of ammonia-water mixtures and introduce pressure-temperature-concentration ( $p$ - $T$ - $\xi$ ) and enthalpy-temperature-concentration ( $h$ - $T$ - $\xi$ ) charts (*Section 16.2*)
3. Analyze some basic steady flow processes using ammonia-water mixtures such as adiabatic and non-adiabatic mixing, throttling of solution streams and the concept of rectification (*Section 16.3*)

At the end of the lecture, the student should be able to:

1. Differentiate between water-lithium bromide and ammonia-water systems vis-à-vis their properties
2. Explain the concepts of bubble point and dew point temperatures
3. Obtain thermodynamic properties of ammonia-water mixtures using  $p$ - $T$ - $\xi$  and  $h$ - $T$ - $\xi$  charts
4. Analyze important steady flow processes involving binary mixtures

### 16.1. Introduction

In vapour absorption refrigeration systems based on ammonia-water pair, ammonia is the refrigerant and water is the absorbent. These systems are more versatile than systems based on water-lithium bromide as they can be used for both sub-zero (refrigeration) as well above  $0^{\circ}\text{C}$  (air conditioning) applications. However, these systems are more complex in design and operation due to the smaller boiling point temperature difference between the refrigerant and absorbent (about  $133^{\circ}\text{C}$ ). Due to the smaller boiling point temperature difference the vapour generated in the generator consists of both ammonia as well as water. If water is allowed to circulate with ammonia in the refrigerant circuit, then:

- i. Heat transfer in condenser and evaporator becomes non-isothermal
- ii. Evaporator temperature increases
- iii. Evaporation will not be complete
- iv. Water may get accumulated in the evaporator leading to malfunctioning of the plant
- iv. Circulation ratio increases

Since all the above effects are detrimental to the performance of the system, it is necessary to minimize the concentration of water vapour in ammonia at the inlet to the condenser. This requires additional components, namely a rectification column and a dephlegmator between generator and absorber, which increases the design complexity and cost and also reduces the system COP compared to water-lithium bromide system.



## 16.2. Properties of ammonia-water solutions

### 16.2.1. Composition

Similar to water-lithium bromide solutions, the composition of ammonia-water solution is also expressed either in mass fraction ( $\xi$ ) or mole fraction ( $x$ ). However, for ammonia-water solutions, the mass and mole fractions are defined in terms of ammonia. For example the mass fraction  $\xi$  is defined as the ratio of mass of ammonia to the total mass of solution, i.e.,

$$\xi = \frac{m_A}{m_A + m_W} \quad (16.1)$$

where  $m_A$  and  $m_W$  are the mass of ammonia and water in solution, respectively.

Similarly, the mole fraction of ammonia-water solution is defined as:

$$x = \frac{n_A}{n_A + n_W} \quad (16.2)$$

where  $n_A$  and  $n_W$  are the number of moles of ammonia and water in solution, respectively. The number of moles of ammonia and water can easily be obtained from their respective masses in solution and molecular weights, thus;

$$n_A = \frac{m_A}{M_A}; \text{ and } n_W = \frac{m_W}{M_W} \quad (16.3)$$

where  $M_A$  (= 17.0 kg/kmol) and  $M_W$  (= 18.0 kg/kmol) are the molecular weights of ammonia and water respectively.

### 16.2.2. Vapour pressure of ammonia-water solutions

Liquid ammonia and water are completely miscible in all proportions, hence can form solutions of all concentrations from 0 to 1, at normal temperatures. The effect of ammonia in water is to lower the vapour pressure of water, similarly the effect of water in ammonia is to lower ammonia's vapour pressure. Thus the total pressure over ammonia-water solutions is made up of partial pressure of ammonia and partial pressure of water vapour, and is always in between the saturation pressures of pure ammonia and water.

If Raoult's law is applied to ammonia-water mixtures, then the total pressure at any temperature,  $P_{\text{total}}$  is given by:

$$P_{\text{total}} = xP_A + (1-x)P_W \quad (16.4)$$

where  $x$  is the liquid phase mole fraction of ammonia,  $P_A$  and  $P_W$  are the saturation pressures of pure ammonia and pure water at that temperature.

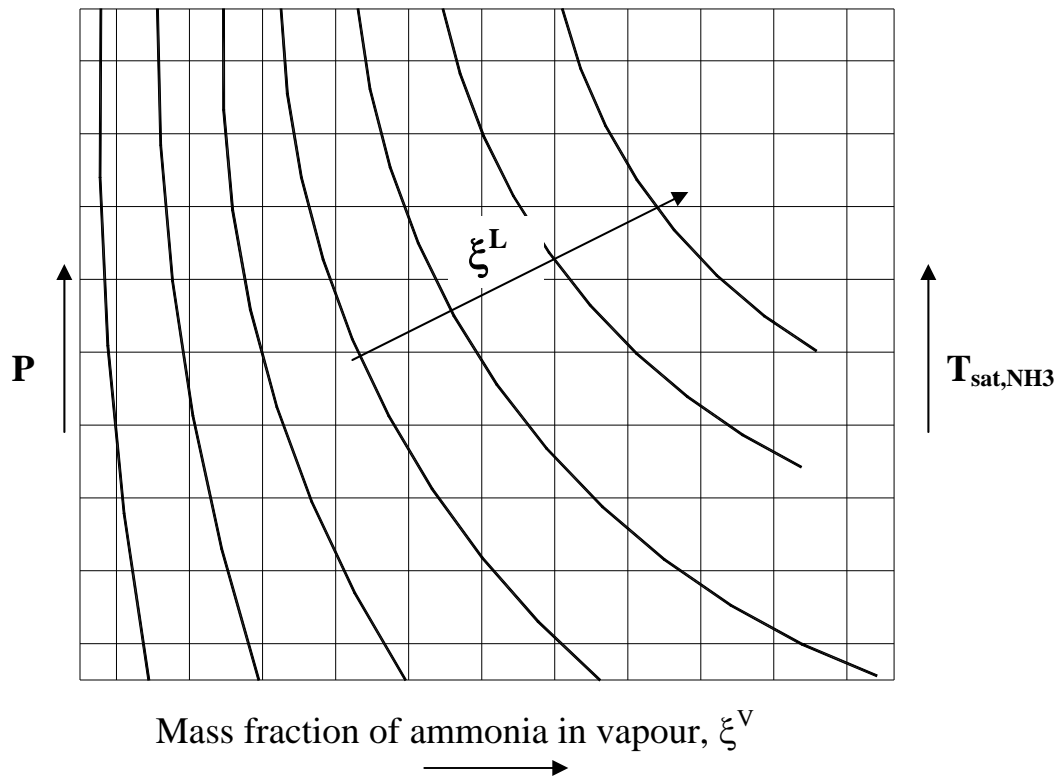
However, similar to water-lithium bromide solutions, ammonia-water solutions also deviate from ideal solution behaviour predicted by Raoult's law in a negative manner, i.e., at a given temperature of the solution the actual vapour pressure will be less than that predicted by Raoult's law (activity coefficient is much smaller than 1.0).

For example, at a mass fraction of 0.4 and temperature of 40°C, Raoult's law predicts a vapour pressure of 6.47 bar, whereas the measured vapour pressure is 3.029 bar.

The vapour pressure data of ammonia-water solutions is also available in the form of Dühring and other P-T- $\xi$  plots.

### **16.2.3. Composition of ammonia-water vapour**

Since the vapour above ammonia-water liquid consists of both ammonia and water vapour, it is essential to distinguish between the composition in liquid phase and composition in vapour phase. The superscripts L and V will be used to distinguish between liquid and vapour phase compositions. Thus  $\xi^L$  stands for liquid phase mass fraction and  $\xi^V$  stands for vapour phase mass fraction. Though the vapour phase composition, can be obtained by assuming ideal solution behaviour, it is observed that the actual vapour composition deviates from that predicted by ideal mixture equations. Based on experimental measurements, charts have been developed for obtaining composition of ammonia-water mixture in vapour phase in equilibrium with a solution of ammonia and water at different temperatures. Figure 16.1 shows the construction of such a chart using which one can obtain the composition of mixture in vapour phase from known values of liquid phase mass fraction ( $\xi^L$ ) and saturated temperature of pure ammonia or pressure.

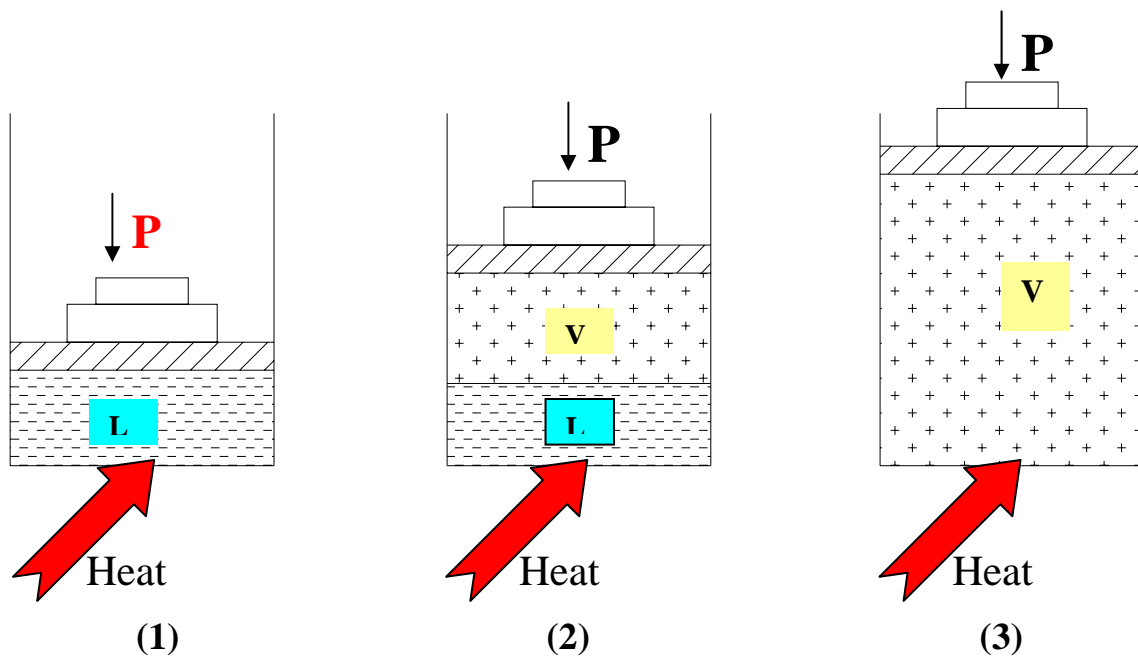


*Fig.16.1. Vapour-liquid equilibrium chart for ammonia-water solution*

#### **16.2.4. Bubble point and dew point for ammonia-water mixtures**

Figure 16.2 shows a cylinder containing mixture of ammonia and water. The pressure on the mixture is maintained constant with the help of a free-floating piston with fixed weights. Initially (State 1) the cylinder consists of subcooled solution of ammonia-water mixture. Now heat is supplied to the system and the temperature of the solution is increased steadily, the mass fraction of the solution remains constant at  $\xi_1$  initially. At a certain temperature the first vapour bubble appears. The temperature at which the first bubble appears is called as bubble point ( $=T_{\text{bubble}}$ ) of the solution at that concentration and pressure. Further heating results in increase in temperature and formation of more vapour as shown in the figure (State 2). If heating is continued further, then the temperature

increases continuously, as more liquid is converted into vapour, and finally at a particular temperature the last liquid droplet vaporizes. The temperature at which the last liquid droplet evaporates is called as dew point temperature ( $T_{\text{dew}}$ ). When heating is continued further the mixture enters into superheated vapour state (State 3). It should be noted that unlike pure fluids, the temperature of the ammonia-water mixture increases continuously as the liquid undergoes vaporization. This is to say that the phase change process is characterized by a temperature glide, which is the difference between the dew point and bubble point temperatures. If this process is repeated with different initial concentrations starting from 0 (pure water) to 1 (pure ammonia) and at the same pressure, different values of bubble and dew points will be obtained. Of course when the concentration is 0 (pure water) or 1 (pure ammonia) the bubble and dew points coincide. Now if we plot the temperatures (bubble point and dew point) against concentration and join all the bubble points by a curve and all the dew points by another curve, then we would get the equilibrium Temperature vs concentration curve for ammonia-water mixtures at that pressure as shown in Fig.16.3. The loci of all the bubble points is called as bubble point line and the loci of all the dew points is known as the dew point line. The bubble point line is the saturated liquid line and the dew point line is the saturated vapour line for the mixture at that pressure. The region between the bubble and dew point lines is the two-phase region where both liquid and vapour coexist in equilibrium. Different bubble point and dew point lines will be obtained if the experiment is carried out with different pressures. For example, Figure 16.4 shows the bubble and dew point lines for two different pressures,  $P_1$  and  $P_2$ . The same results can also be obtained if one starts the experiment initially with superheated vapour and then start cooling it. In this case, the dew point is the temperature at which the first liquid droplet forms from the vapour and the bubble point is the temperature at which the last vapour bubble condenses.



*Fig.16.2: A simple experiment illustrating the principle of bubble and dew points*

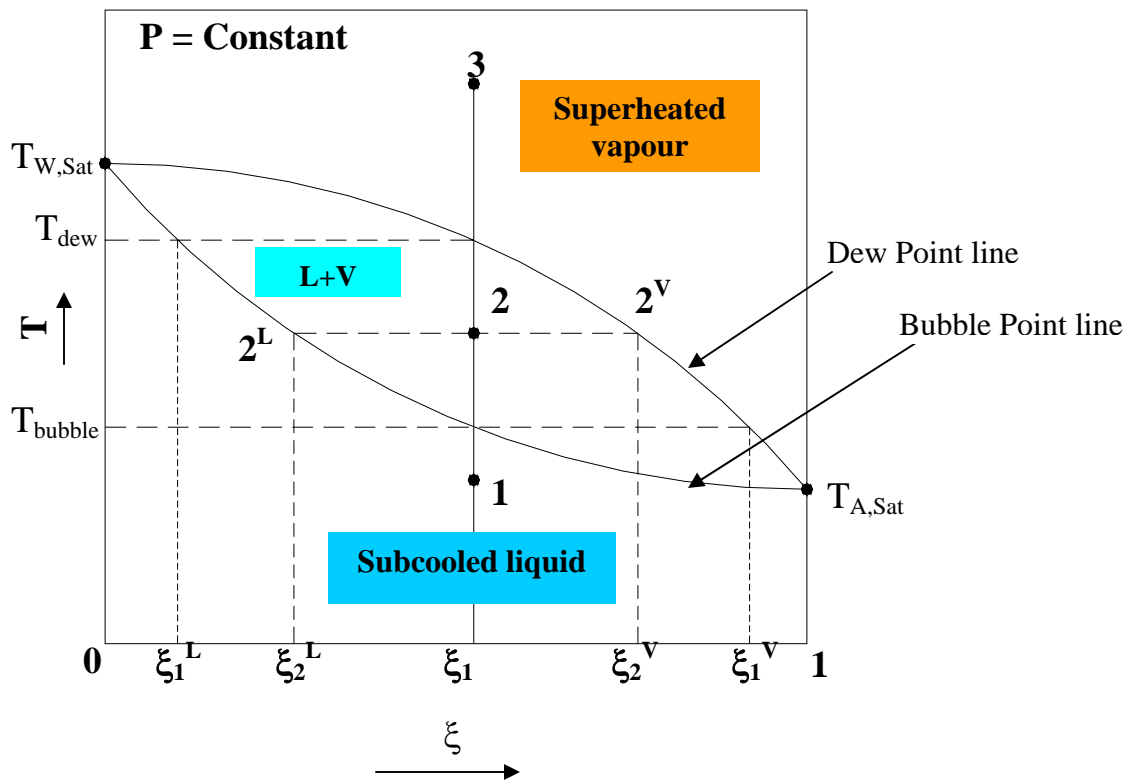


Fig.16.3: Equilibrium temperature-concentration curve for  $\text{NH}_3\text{-H}_2\text{O}$  at a constant pressure

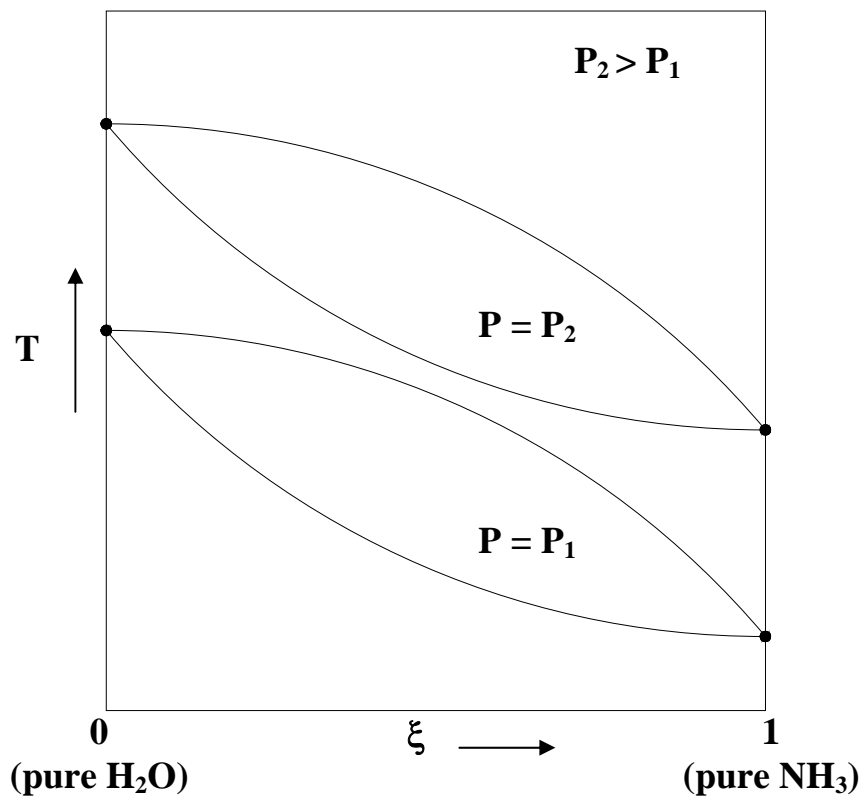


Fig.16.4: Bubble point and dew point curves at two different pressures

Now since the process is carried out in a closed system, the mass of both ammonia and water will be conserved. The concentration of subcooled liquid will be same as the concentration of superheated vapour. However, in the two-phase region in which the saturated liquid exists in equilibrium with saturated vapour, the concentration of liquid and vapour will be different. For example, at point 2 in Fig.16.3, the temperature of saturated liquid and vapour will be same as they are in equilibrium, hence, the concentration of liquid will be  $\xi_2^L$  (**intersection of constant temperature line with bubble point line**) and that of vapour will be  $\xi_2^V$  (**intersection of constant temperature line with dew point line**) as shown in the figure. Obviously the vapour formed initially will be richer in the low boiling point substance (ammonia) and the liquid remaining will be rich in high boiling point substance (water). For example, as shown in Fig.16.3, the concentration of the first vapour bubble will be  $\xi_1^V$  and the concentration of the last liquid droplet will be  $\xi_1^L$ . Since the total mass as well as mass of individual components is always conserved, we can write mass balance for total mass ( $m_{total}$ ) and ammonia ( $m_A$ ) mass at state 2 as:

$$m_{total} = m_2^L + m_2^V \quad (16.5)$$

$$m_A = \xi_2^L m_2^L + \xi_2^V m_2^V = \xi_1 m_{total} \quad (16.6)$$

where  $m_2^L$  and  $m_2^V$  are the mass of liquid and vapour at state 2, respectively.

From the above equations it can be easily shown that:

$$\frac{m_2^L}{m_2^V} = \left( \frac{\xi_2^V - \xi_1}{\xi_1 - \xi_2^L} \right), \text{ or} \quad (16.7)$$

$$m_2^L (\xi_1 - \xi_2^L) = m_2^V (\xi_2^V - \xi_1) \quad (16.8)$$

The above equation is called as the *mixing rule or lever rule* for the binary mixtures such as ammonia and water. It implies that the fraction of liquid and vapour in the two-phase mixture is inversely proportional to the distance between the mixture condition 2 and the saturated liquid and vapour states  $2^L$  and  $2^V$ , respectively.

### 16.2.5. Enthalpy of ammonia-water mixtures

#### Liquid phase:

The enthalpy of ammonia-water solution in liquid phase,  $h^L$  is calculated in a manner similar to that of water-lithium bromide solutions, i.e., by the equation:

$$h^L = \xi^L h_A^L + (1 - \xi^L) h_W^L + \Delta h_{mix} \quad (16.9)$$

where  $\xi^L$  is the liquid phase mass fraction of ammonia,  $h_A^L$  and  $h_W^L$  are liquid phase enthalpies of pure ammonia and water respectively.  $\Delta h_{\text{mix}}$  is the heat of mixing, which is negative (exothermic) similar to water-lithium bromide mixtures.

Using the above equation one can calculate the specific enthalpy of ammonia-water solutions at any concentration and temperature provided the heat of mixing is known from measurements. Thus enthalpy charts for solution are plotted as a field of isotherms against mass fraction by taking suitable reference values for enthalpy of ammonia and water. Since pressure does not have a significant effect on liquid enthalpy (except at critical point), normally pressure lines are not shown on typical solution enthalpy charts. Also **enthalpy of subcooled liquid is generally assumed to be equal to the saturated enthalpy at that temperature without loss of much accuracy.**

### Vapour phase:

Evaluation of enthalpy of a mixture of vapours of ammonia and water is more complicated compared to liquid phase enthalpy. This is due to the dependence of vapour enthalpy on both temperature and pressure. However, to simplify the problem, it is generally assumed that ammonia and water vapour mix without any heat of mixing. Then the enthalpy of the vapour mixture,  $h^V$  is given by:

$$h^V = \xi^V h_A^V + (1 - \xi^V) h_W^V \quad (16.10)$$

where  $\xi^V$  is the vapour phase mass fraction of ammonia and  $h_A^V$  and  $h_W^V$  are the specific enthalpies of ammonia vapour and water vapour respectively at the temperature of the mixture. However, since vapour enthalpies depend on temperature as well as pressure, one has to evaluate the vapour enthalpy at suitable pressure, which is not equal to the total pressure. An approximate, but practically useful method is to evaluate the vapour enthalpies of ammonia and water at pressures,  $P_A$  and  $P_W$  given by:

$$P_A = y P_{\text{total}} \quad (16.11)$$

$$P_W = (1 - y) P_{\text{total}}$$

where  $y$  is the vapour phase mole fraction of ammonia and  $P_{\text{total}}$  is the total pressure. It should be noted that  $P_A$  and  $P_W$  are equal to the partial pressures of ammonia and water only if they behave as ideal gases. However since ammonia and water vapour may not approach the ideal gas behaviour at all temperatures and pressures, in general  $P_A$  and  $P_W$  are not equal to the partial pressures. Using this method enthalpies of ammonia-water mixtures in vapour phase have been obtained as functions of temperature and mass fraction.

### 16.2.6. The complete enthalpy-composition diagram for ammonia-water mixtures:

Normally, charts of enthalpy-temperature-mass fraction are available which give both liquid phase as well as vapour enthalpy of mixtures. Figure 16.5 shows one such chart. Figure 16.6 shows the enthalpy-composition diagram at a constant pressure P. In the figure point **a** represents the condition of saturated liquid mixture at a temperature T with a liquid phase mass fraction of  $\xi^L$ . The liquid phase enthalpy corresponding to this condition is given by  $h^L$ . The composition and enthalpy of vapour mixture in equilibrium with the liquid mixture at temperature T and pressure P are obtained by drawing a vertical line from **a** upto the auxiliary line and then drawing a horizontal line to the right from the intersection of the vertical line with the auxiliary line. The intersection of this horizontal line with the dew point line **a'** gives the vapour phase mass fraction  $\xi^V$  and the vapour phase enthalpy  $h^V$  as shown in the figure. The isotherm T in the two-phase region is obtained by joining points **a** and **a'** as shown in the figure. Point **b** in the figure lies in the two-phase region. The specific enthalpy of this point  $h_b$  is given by:

$$h_b = (1 - \psi_b)h^L + \psi_b h^V \quad (16.12)$$

where  $\psi_b$  is the quality or dryness fraction of the two-phase mixture at b. Since points a, a' and b are co-linear, the dryness fraction  $\psi_b$  is given by:

$$\psi_b = \frac{\xi_b - \xi^L}{\xi^V - \xi^L} \quad (16.13)$$

In actual enthalpy-composition diagrams the isotherms are not shown in two-phase region as a different set of them exist for each pressure.

It is important to note that it is not possible to fix the state of the mixture (subcooled, saturated, two-phase or superheated) just from temperature and mass fraction alone, though one can calculate enthalpy of the mixture from temperature and mass fraction. This is due to the reason that at a given mass fraction and temperature, depending upon the pressure the point can be subcooled or saturated or superheated.

For example, a liquid mixture with a mass fraction of 0.4 and temperature of 80°C has an enthalpy of 210 kJ/kg, and it will be in subcooled condition if the pressure is 4.29 bar and saturated if the pressure is 8.75 bar.



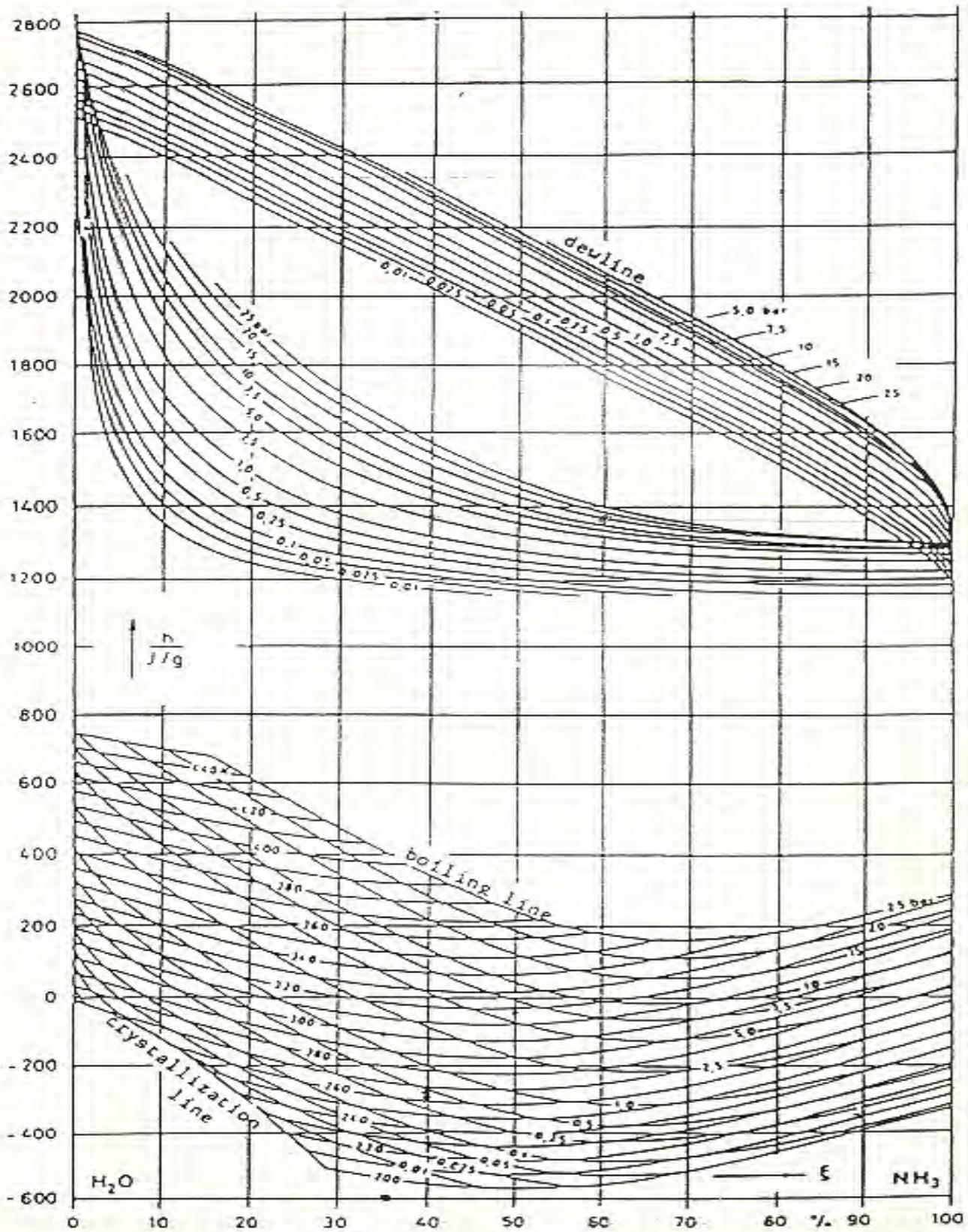
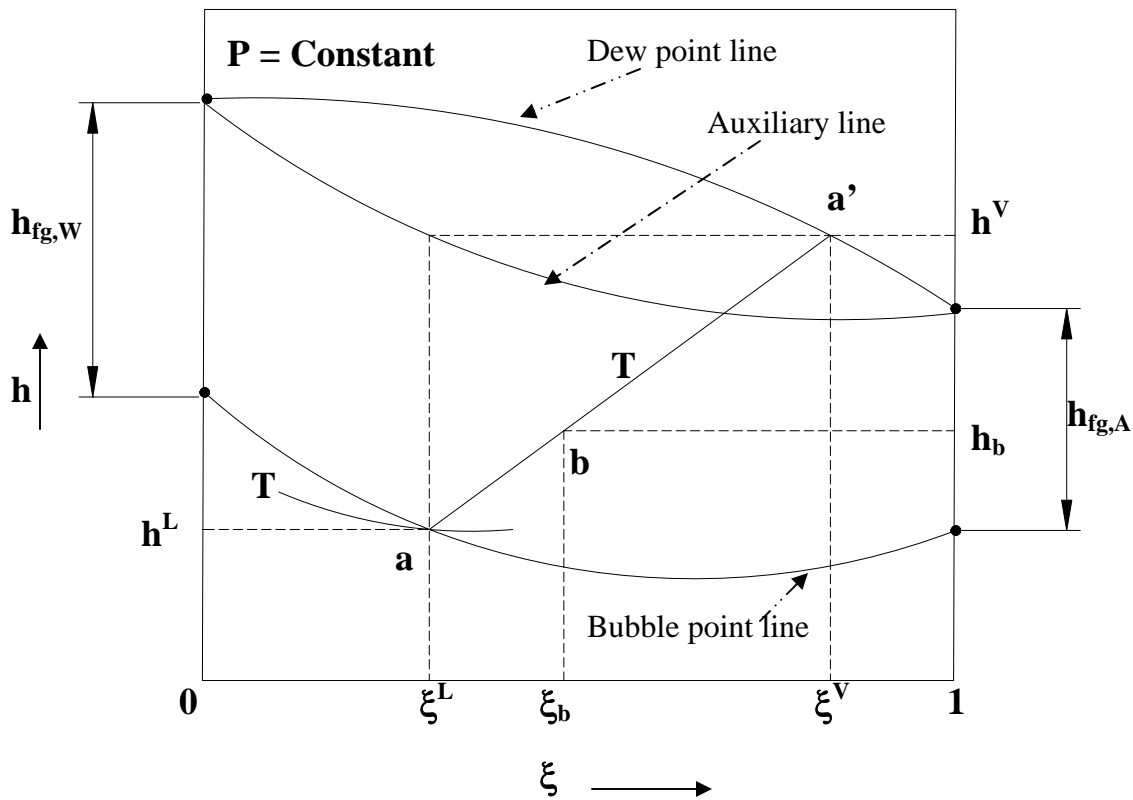


Fig.16.5:  $h$ - $T$ - $\xi$  chart for ammonia-water solution



**Fig.16.6:** Enthalpy-composition diagram of  $\text{NH}_3\text{-H}_2\text{O}$  at a constant pressure  $P$

**Determination of temperature of mixture in two-phase region:**

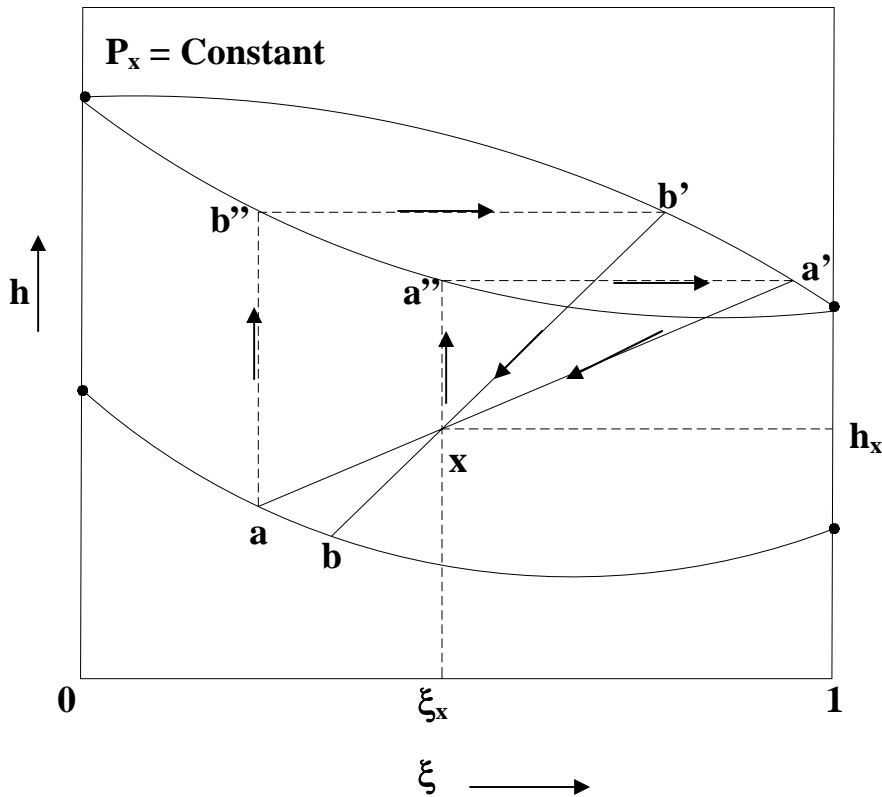
A trial-and-error method has to be used to determine the temperature of a point in two-phase region if its enthalpy, liquid phase mass fraction and pressure are known. The trial-and-error method can be graphical or numerical. Figure 16.7 shows a graphical method for finding the temperature of point  $x$  in the two-phase region which is at a known pressure  $P_x$ , liquid phase mass fraction  $\xi_x$  and enthalpy  $h_x$ . To start with, point  $a'$  is obtained as shown in the figure by drawing a vertical line from point  $x$  upto the auxiliary line and then drawing a horizontal line from the intersection point  $a''$  upto the dew point line, the intersection of which gives  $a'$ . Then a straight line  $a'-x-a$  is drawn as shown. Next point  $b'$  is obtained by drawing a vertical line upto the auxiliary line and then drawing a horizontal line from  $b''$  upto the dew point line to get  $b'$ . Then line  $b'-x-b$  is drawn passing through  $x$ . This procedure is repeated until convergence is obtained.

Numerically the temperature can be obtained from the equation, which needs to be satisfied for each end of the isotherm passing through  $x$ , i.e.,

$$\frac{h^V - h_x}{\xi^V - \xi_x} = \frac{h_x - h^L}{\xi_x - \xi^L} \tag{16.14}$$

To start with guess values of  $h^L$  and  $\xi^L$  are assumed by taking some point on the bubble point line. Then saturated vapour properties  $h^V$  and  $\xi^V$  are obtained from the enthalpy-composition charts using the guess values of  $h^L$  and  $\xi^L$ . Then using the above equation,

new values of  $h^L$  and  $\xi^L$  are obtained. Then these new values are used to obtain next set of  $h^V$  and  $\xi^V$ . This procedure is repeated till the values converge. Once the converged values of  $h^L$  and  $\xi^L$  are obtained then the temperature is read from the enthalpy-composition chart.



*Fig.16.7: A graphical method for finding temperature of liquid-vapour mixture*

### 16.3. Basic steady-flow processes with binary mixtures

a) Adiabatic mixing of two streams: When two streams of ammonia-water solutions are mixed adiabatically as shown in Fig.16.8, one can write mass and energy balance equations as:

$$m_1 + m_2 = m_3 \quad (16.15)$$

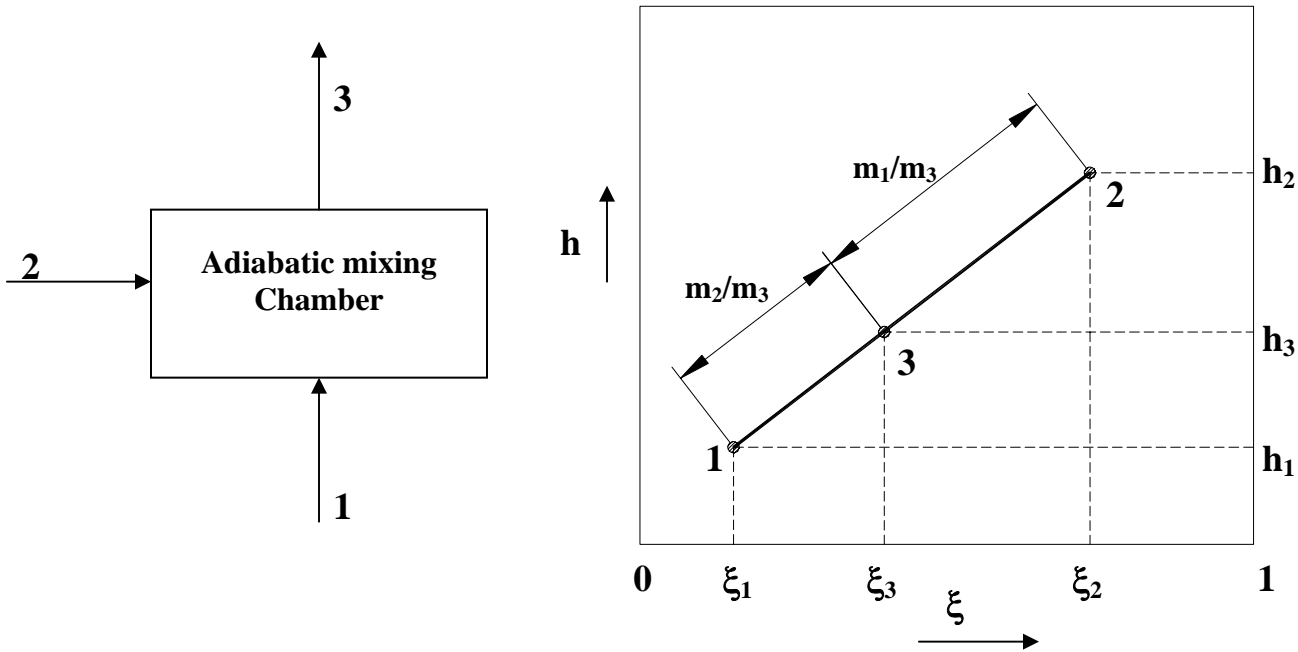
$$m_1 \xi_1 + m_2 \xi_2 = m_3 \xi_3 \quad (16.16)$$

$$m_1 h_1 + m_2 h_2 = m_3 h_3 \quad (16.17)$$

From the above equations, the mass fraction and enthalpy of the mixture at 3 are given by:

$$\xi_3 = \xi_1 + \frac{m_2}{m_3} (\xi_2 - \xi_1) \quad (16.18)$$

$$h_3 = h_1 + \frac{m_2}{m_3} (h_2 - h_1) \quad (16.19)$$

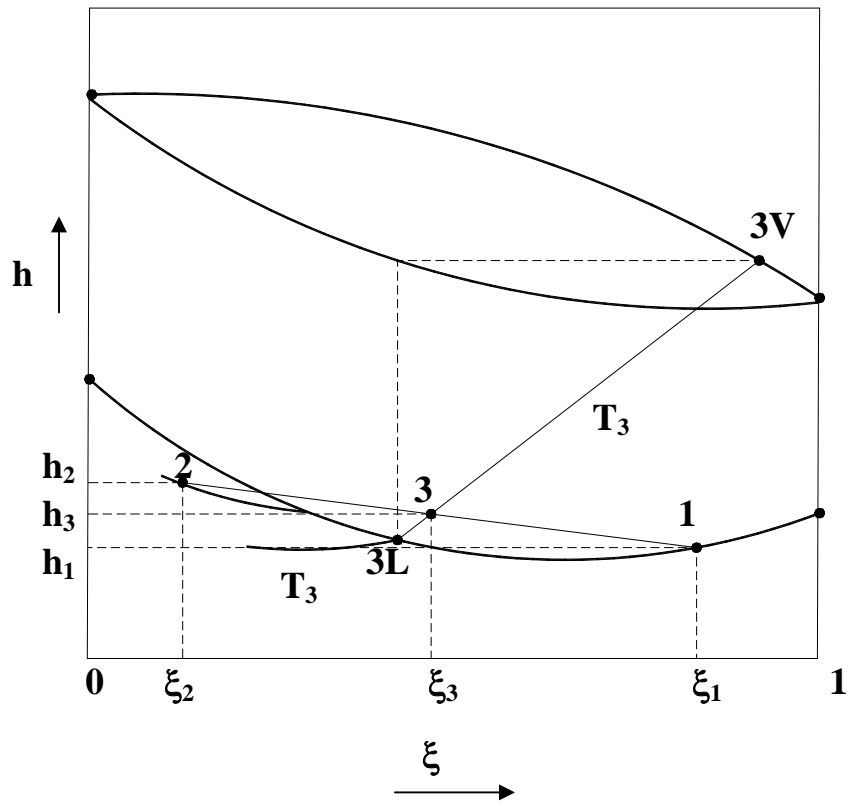


**Fig.16.8:** Adiabatic mixing of two solution streams

Figure 16.9 shows the adiabatic mixing process with the mixture state 3 lying in two-phase region on the enthalpy-composition diagram. The mixture state in two-phase region implies that some vaporization has occurred during adiabatic mixing of the two inlet streams 1 and 2. The enthalpy and composition of the two-phase mixture at 3 can be obtained by using the equations given above. However, since this is in two-phase region, the mixture consists of saturated liquid and vapour. The dryness fraction and temperature of the mixture ( $T_3$ ) have to be obtained by trial-and-error method by applying mixing rules. The fraction of the vapour in the mixture at 3 is then given by:

$$\frac{m_3^V}{m_3} = \frac{\xi_3 - \xi_3^L}{\xi_3^V - \xi_3^L} = \frac{33L}{3V3L} \quad (16.20)$$

**b) Mixing of two streams with heat transfer:** The process of mixing of two streams with heat transfer takes place in absorber and generator of absorption refrigeration systems. For example, Fig.16.10 shows the mixing of saturated refrigerant vapour (state 1) with saturated solution of refrigerant-absorbent (state 2) in the absorber. The resulting mixture is a solution that is rich in refrigerant (state 3). Since the process is exothermic, heat ( $Q$ ) is released during this process. Mass and energy balance equations for this process can be written as:



*Fig.16.9: Adiabatic mixing of two streams on  $h$ - $T$ - $\xi$  diagram*

$$m_1 + m_2 = m_3 \quad (16.21)$$

$$m_1 \xi_1 + m_2 \xi_2 = m_3 \xi_3 \quad (16.22)$$

$$m_1 h_1 + m_2 h_2 = m_3 h_3 + Q \quad (16.23)$$

From the above equations, the enthalpy of the mixture at 3 is given by:

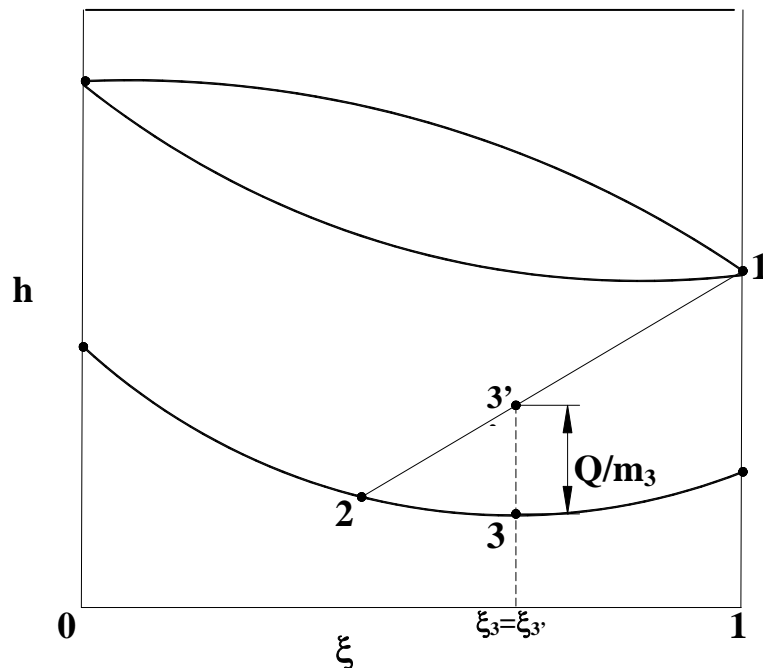
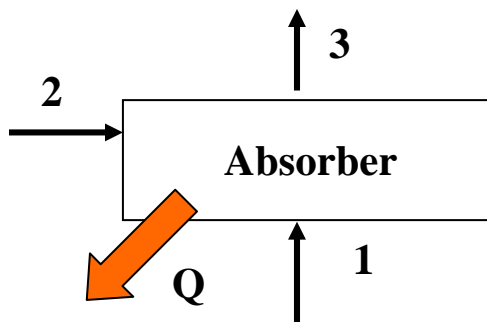
$$h_3 = h_1 + \frac{m_2}{m_3} (h_2 - h_1) - \frac{Q}{m_3} \quad (16.24)$$

Thus with heat transfer from the mixing chamber, the exit state lies at a vertical distance of  $(Q/m_3)$  below the state which would result without heat transfer (point 3'). The exit point would lie above the state without heat transfer if heat is transferred to the mixing chamber.

c) Throttling process: Throttling or isenthalpic expansion of ammonia-water solution takes place in the solution expansion valve of the absorption refrigeration system. Figure 16.11 shows the throttling process on enthalpy-composition diagram. Since both mass and energy are conserved during this process, and there is neither work nor heat transfer, we obtain:

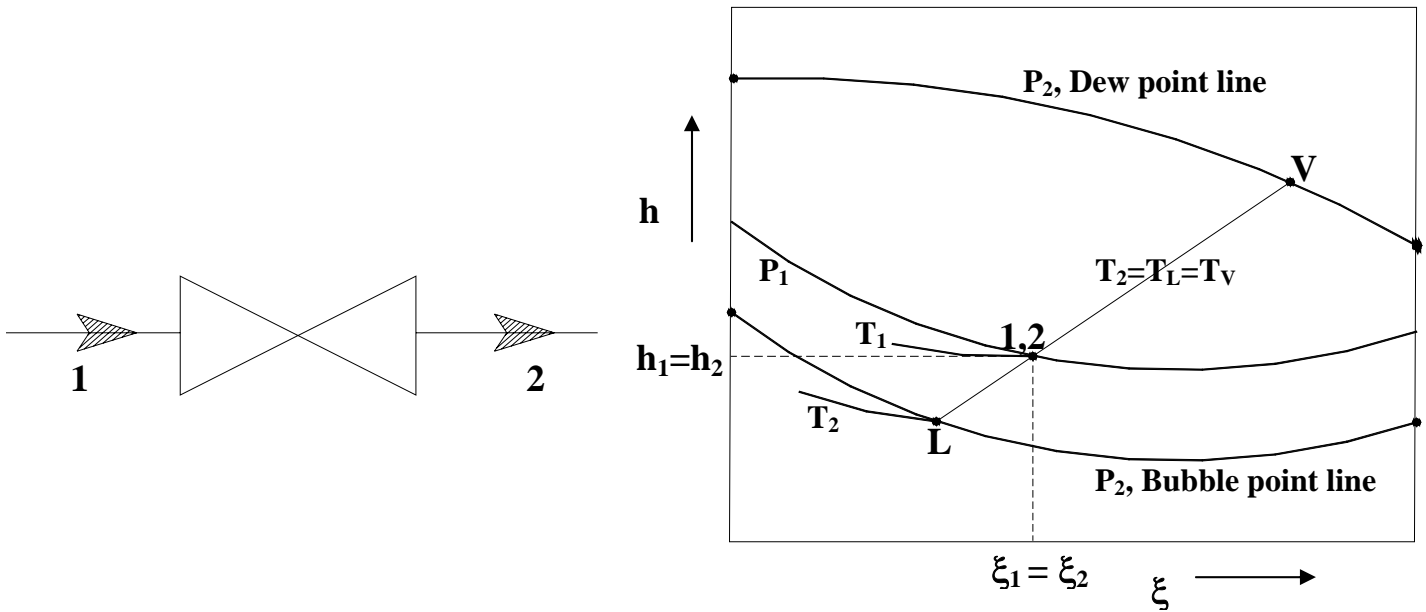
$$\xi_1 = \xi_2 \quad (16.25)$$

$$h_1 = h_2 \quad (16.26)$$



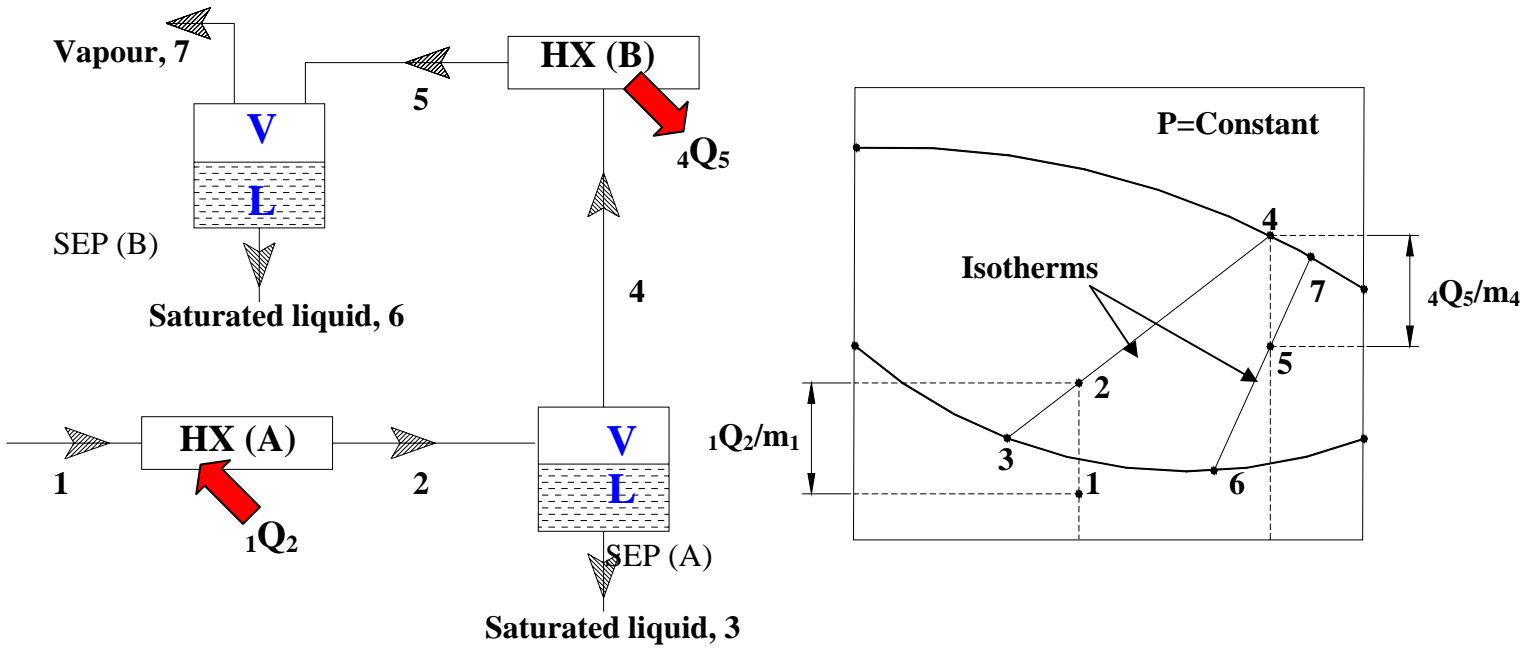
*Fig.16.10: Mixing of two streams with heat transfer*

Hence the inlet and outlet states, points 1 and 2 are identical on enthalpy-composition diagram as shown in the figure. However, as there is possibility of vapour generation due to flashing, the exit condition may be a mixture of saturated liquid and vapour at the outlet pressure  $P_2$  then the exit temperature  $T_2$  will be much lower than the inlet temperature  $T_1$ . Taking point 2 as in the two-phase region corresponding to the outlet pressure  $P_2$ , one can get the vapour fraction and exit temperature  $T_2$  by trial-and-error method as discussed earlier.



**Fig.16.11:** Throttling of ammonia-water solution

d) Heating and cooling process – concept of rectification: Figure 16.12 shows an arrangement wherein an initially subcooled solution (state 1) is heated in a heat exchanger A (HX A) in such a way that the exit condition 2 lies in the two-phase region. This two-phase mixture then flows into an adiabatic separator (SEP A) where the saturated liquid (state 3) and saturated vapour (state 4) are separated. The saturated vapour at state 4 is then cooled to state 5 in another heat exchanger B (HX B) by rejecting heat  $4Q_5$ . The resulting two-phase mixture is then fed to another adiabatic separator B (SEP B), where again the saturated liquid (state 6) and saturated vapour (state 7) are separated. It is assumed that the entire process takes place at a constant pressure and is a steady-flow process.



*Fig.16.12: Heating and cooling of  $\text{NH}_3\text{-H}_2\text{O}$  solution – concept of rectification*

Now mass and energy balances are applied to each of the components as shown below:

**Heat exchanger A:**

Mass balance:

$$m_1 = m_2 \quad (16.27)$$

$$\xi_1 = \xi_2 \quad (16.28)$$

Energy balance:

$${}_1Q_2 = m_1(h_2 - h_1) \quad (16.29)$$

**Separator A:**

Mass balance:

$$m_2 = m_3 + m_4 \quad (16.30)$$

$$m_2 \xi_2 = m_3 \xi_3 + m_4 \xi_4 \quad (16.31)$$

Energy balance:



$$m_2 h_2 = m_3 h_3 + m_4 h_4 \quad (16.32)$$

from the above equations:

$$\frac{m_3}{m_2} = \frac{\xi_4 - \xi_2}{\xi_4 - \xi_3} = \frac{h_4 - h_2}{h_4 - h_3} = \frac{\text{length } 4-2}{\text{length } 4-3} \quad (16.33)$$

$$\frac{m_4}{m_2} = \frac{\xi_2 - \xi_3}{\xi_4 - \xi_3} = \frac{h_2 - h_3}{h_4 - h_3} = \frac{\text{length } 2-3}{\text{length } 4-3} \quad (16.34)$$

Similar equations can be obtained for heat exchanger B and separator B. The entire process is also shown on enthalpy-composition diagram in Fig.16.12.

It may be noted that from the above arrangement consisting of heating, cooling and separation, one finally obtains a vapour at state 7 that is rich in ammonia. That is the combination of heat exchangers with separators is equivalent to the process of rectification. Heat exchanger A plays the role of generator, while heat exchanger B plays the role of dephlegmator. To improve the process of rectification in actual vapour absorption refrigeration systems, a rectifying column is introduced between the generator and dephlegmator. In the rectifying column, the vapour from the separator A comes in contact with the saturated liquid coming from separator B. As a result, there will be heat and mass transfer between the vapour and liquid and finally the vapour comes out at a much higher concentration of ammonia.

The practical ammonia-water based vapour absorption refrigeration system incorporating rectifying column and dephlegmator in addition to the basic components will be discussed in the next lesson.

## Questions and Answers:

1. Presence of water vapour in the refrigerant circuit of a  $\text{NH}_3\text{-H}_2\text{O}$  system:

- a) Decreases evaporator temperature
- b) Increases evaporator temperature
- c) Increases circulation ratio
- d) Leads to non-isothermal heat transfer in evaporator and condenser

**Ans. b), c) and d)**

2. Compared to  $\text{H}_2\text{O-LiBr}$  systems, a  $\text{NH}_3\text{-H}_2\text{O}$  system:

- a) Requires additional components due to the requirement of rectification
- b) Yields higher COP
- c) Yields lower COP
- d) Increases design complexity and system cost

**Ans. a), c) and d)**

3. Which of the following statements regarding the definition of concentration are TRUE:

- a) A strong solution of H<sub>2</sub>O-LiBr implies a solution rich in refrigerant
- b) A strong solution of H<sub>2</sub>O-LiBr implies a solution weak in refrigerant
- c) A strong solution of NH<sub>3</sub>-H<sub>2</sub>O implies a solution rich in refrigerant
- d) A strong solution of NH<sub>3</sub>-H<sub>2</sub>O implies a solution weak in refrigerant

**Ans. b) and c)**

4. Which of the following statements regarding NH<sub>3</sub>-H<sub>2</sub>O solution are TRUE:

- a) The bubble point temperature is always higher than dew point temperature
- b) The bubble point temperature is always lower than dew point temperature
- c) At a given pressure, the bubble point and dew point temperatures are higher than the saturation temperature of NH<sub>3</sub> but lower than the saturation temperature of H<sub>2</sub>O
- d) At a given pressure, the bubble point and dew point temperatures are lower than the saturation temperature of NH<sub>3</sub> but higher than the saturation temperature of H<sub>2</sub>O

**Ans.: b) and c)**

5. For NH<sub>3</sub>-H<sub>2</sub>O solution at equilibrium, which of the following statements are FALSE:

- a) The concentration of liquid phase is lower than the concentration of vapour phase
- b) The enthalpy of subcooled solution is a function of temperature and pressure
- c) The enthalpy of superheated vapour is a function of temperature only
- d) The state of the mixture can be uniquely determined by temperature and concentration

**Ans.: b) and d)**

6. When a binary solution of NH<sub>3</sub>-H<sub>2</sub>O is throttled adiabatically:

- a) Temperature always remains constant
- b) Temperature may decrease
- c) Temperature may increase
- d) Enthalpy always remains constant

**Ans.: b) and d)**

7. A binary mixture of NH<sub>3</sub> - H<sub>2</sub>O is at a temperature of **40°C** and a liquid phase mole fraction  $x$  of **0.5**. Find the vapour pressure of the solution, if the activity coefficient of the solution is **0.65**. The saturation pressures of ammonia and water at 40°C are 1557 kPa and 7.375 kPa, respectively.

**Ans.:** From Raoult's law, the vapour pressure is given by:

$$P_{v,Raoult} = x.P_{sat,NH_3} + (1 - x).P_{sat,H_2O} = 782.19 \text{ kPa}$$

Using the definition of activity coefficient,  $a$ ; the actual vapour pressure  $P_v$  is given by:

$$P_{v,act} = a.P_{v,Raoult} = 0.65 \times 782.19 = 508.42 \text{ kPa} \quad (\text{Ans.})$$

8. A binary vapour mixture consisting of ammonia and water is at a mole fraction of 0.9 and 10°C. If the partial pressures of ammonia and water vapour in the mixture are 616.25 kPa and 1.227 kPa, respectively; and the specific vapour enthalpies of ammonia and water are 1471.57 kJ/kg and 2519.9 kJ/kg, respectively, find a) the vapour pressure of the mixture, and b) the specific enthalpy of the mixture.

**Ans.:**

a) Assume the vapour mixture to behave as a mixture of ideal gases, then the total pressure of the mixture  $P_v$  is given by:

$$P_v = y.P_{NH_3} + (1 - y).P_{H_2O} = 554.75 \text{ kPa} \quad (\text{Ans.})$$

b) The mass fraction of the mixture  $\xi^V$  is given by:

$$\xi^V = \frac{m_A}{m_A + m_W} = \frac{n_A.M_A}{n_A.M_A + n_W.M_W} = \frac{17n_A}{17n_A + 18n_W}$$

Since the mole fraction of the vapour mixture is 0.9  $\Rightarrow n_A = 9 n_W$

Substituting this in the expression for mass fraction, we find that  $\xi^V = 0.895$

Again assuming the vapour mixture to behave as a mixture of ideal gases; the enthalpy of the mixture is given by:

$$h^V = \xi^V.h_A + (1 - \xi^V)h_W = 1581.64 \text{ kJ/kg} \quad (\text{Ans.})$$

9. Find the dryness fraction (quality) and specific enthalpy of the two-phase (liquid & vapour) of ammonia-water mixture using the following data:

Liquid phase mass fraction, $\xi^L$	= 0.30
Vapour phase mass fraction, $\xi^V$	= 0.87
Mass fraction of 2-phase mixture, $\xi$	= 0.50
Specific enthalpy of saturated liquid, $h^L$	= 340 kJ/kg
Specific enthalpy of saturated vapour, $h^V$	= 1640 kJ/kg

**Ans.:**

$$\text{Dryness fraction, } \psi = \frac{m^V}{m^V + m^L} = \frac{\xi - \xi^L}{\xi^V - \xi^L} = \mathbf{0.351} \quad (\text{Ans.})$$

Enthalpy of the two-phase mixture is given by:

$$\mathbf{h = (1 - \psi)h^L + \psi h^V = 796.3 \text{ kJ/kg}} \quad (\text{Ans.})$$

9. Two solution streams are mixed in a steady flow device. A heat transfer rate of **24 kW** takes place from the device. Find the exit concentration and enthalpy using the data given below:

Stream 1:      Mass flow rate,  $m_1$       = 0.1 kg/s  
                    Concentration,  $\xi_1$          = 0.7  
                    Enthalpy,  $h_1$              = 110 kJ/kg

Stream 2:      Mass flow rate,  $m_2$       = 0.3 kg/s  
                    Concentration,  $\xi_2$          = 0.4  
                    Enthalpy,  $h_2$              = 250 kJ/kg

**Ans.:**

From mass balance of solution and ammonia, the exit concentration is given by  $\xi_3$ :

$$\xi_3 = \frac{(m_1 \xi_1 + m_2 \xi_2)}{(m_1 + m_2)} = \mathbf{0.475} \quad (\text{Ans.})$$

From energy balance of solution and ammonia, the exit concentration is given by  $h_3$ :

$$h_3 = \frac{[(m_1 h_1 + m_2 h_2) - Q]}{(m_1 + m_2)} = \mathbf{155 \text{ kJ/kg}} \quad (\text{Ans.})$$

# Lesson

17

## Vapour Absorption Refrigeration Systems Based On Ammonia- Water Pair

## The specific objectives of this lesson are to:

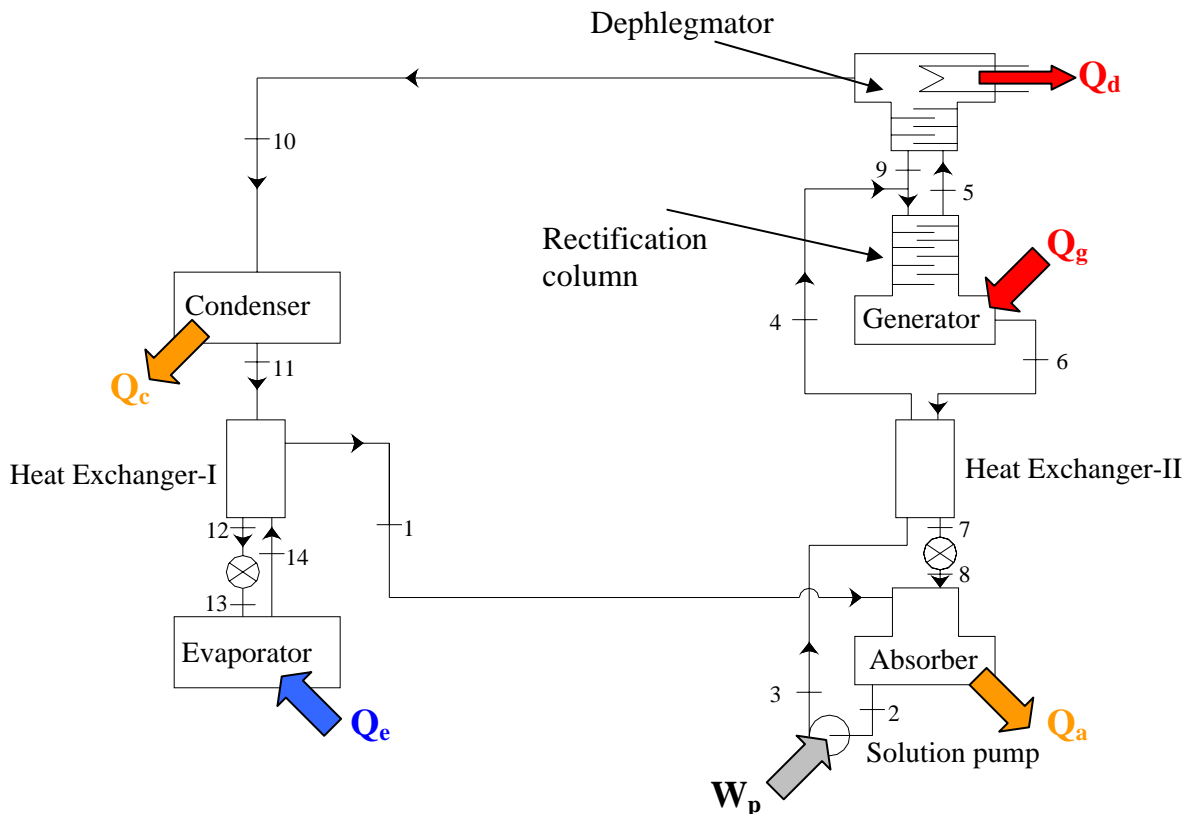
1. Introduce ammonia-water systems (*Section 17.1*)
2. Explain the working principle of vapour absorption refrigeration systems based on ammonia-water (*Section 17.2*)
3. Explain the principle of rectification column and dephlegmator (*Section 17.3*)
4. Present the steady flow analysis of ammonia-water systems (*Section 17.4*)
5. Discuss the working principle of pumpless absorption refrigeration systems (*Section 17.5*)
6. Discuss briefly solar energy based sorption refrigeration systems (*Section 17.6*)
7. Compare compression systems with absorption systems (*Section 17.7*)

At the end of the lecture, the student should be able to:

1. Draw the schematic of a ammonia-water based vapour absorption refrigeration system and explain its working principle
2. Explain the principle of rectification column and dephlegmator using temperature-concentration diagrams
3. Carry out steady flow analysis of absorption systems based on ammonia-water
4. Explain the working principle of Platen-Munter's system
5. List solar energy driven sorption refrigeration systems
6. Compare vapour compression systems with vapour absorption systems

### 17.1. Introduction

Vapour absorption refrigeration system based on ammonia-water is one of the oldest refrigeration systems. As mentioned earlier, in this system ammonia is used as refrigerant and water is used as absorbent. Since the boiling point temperature difference between ammonia and water is not very high, both ammonia and water are generated from the solution in the generator. Since presence of large amount of water in refrigerant circuit is detrimental to system performance, rectification of the generated vapour is carried out using a rectification column and a dephlegmator. Since ammonia is used as the refrigerant, these systems can be used for both refrigeration and air conditioning applications. They are available in very small (as pumpless systems) to large refrigeration capacities in applications ranging from domestic refrigerators to large cold storages. Since ammonia is not compatible with materials such as copper or brass, normally the entire system is fabricated out of steel. Another important difference between this system and water-lithium bromide systems is in the operating pressures. While water-lithium bromide systems operate under very low (high vacuum) pressures, the ammonia-water system is operated at pressures much higher than atmospheric. As a result, problem of air leakage into the system is eliminated. Also this system does not suffer from the problem of crystallization encountered in water-lithium bromide systems. However, unlike water, ammonia is both toxic and flammable. Hence, these systems need safety precautions.



*Fig.17.1: Schematic of NH<sub>3</sub>-H<sub>2</sub>O based vapour absorption refrigeration system*

## 17.2. Working principle

Figure 17.1 shows the schematic of an ammonia-water absorption refrigeration system. Compared to water-lithium bromide systems, this system uses three additional components: a **rectification column**, a **dephlegmator** and a **subcooling heat exchanger** (Heat Exchanger-I). As mentioned before, the function of rectification column and dephlegmator is to reduce the concentration of water vapour at the exit of the generator. Without these the vapour leaving the generator may consist of **five to ten percent of water**. However, with rectification column and dephlegmator the concentration of water is **reduced to less than one percent**. The rectification column could be in the form of a packed bed or a spray column or a perforated plate column in which the vapour and solution exchange heat and mass. It is designed to provide a large residence time for the fluids so that high heat and mass transfer rates could be obtained. The subcooling heat exchanger, which is normally of counterflow type is used to increase the refrigeration effect and to ensure liquid entry into the refrigerant expansion valve.

As shown in the figure, low temperature and low pressure vapour (almost pure ammonia) at state 14 leaves the evaporator, exchanges heat with the condensed liquid in Heat Exchanger-I and enters the absorber at state 1. This refrigerant is absorbed by the weak solution (weak in ammonia) coming from the solution expansion valve, state 8. The heat of absorption,  $Q_a$  is rejected to an external heat sink. Next the strong solution that is now rich in ammonia leaves the absorber at state 2 and is pumped by the solution pump to generator pressure, state 3. This high pressure solution is then pre-heated in the solution heat exchanger

(Heat Exchanger-II) to state 4. The preheated solution at state 4 enters the generator and exchanges heat and mass with the hot vapour flowing out of the generator in the rectification column. In the generator, heat is supplied to the solution ( $Q_g$ ). As a result vapour of ammonia and water are generated in the generator. As mentioned, this hot vapour with five to ten percent of water exchanges heat and mass with the rich solution descending from the top. During this process, the temperature of the vapour and its water content are reduced. This vapour at state 5 then enters the dephlegmator, where most of the water vapour in the mixture is removed by cooling and condensation. Since this process is exothermic, heat ( $Q_d$ ) is rejected to an external heat sink in the dephlegmator. The resulting vapour at state 10, which is almost pure ammonia (mass fraction greater than 99 percent) then enters the condenser and is condensed by rejecting heat of condensation,  $Q_c$  to an external heat sink. The condensed liquid at state 11 is subcooled to state 12 in the subcooling heat exchanger by rejecting heat to the low temperature, low pressure vapour coming from the evaporator. The subcooled, high pressure liquid is then throttled in the refrigerant expansion valve to state 13. The low temperature, low pressure and low quality refrigerant then enters the evaporator, extracts heat from the refrigerated space ( $Q_e$ ) and leaves the evaporator at state 14. From here it enters the subcooling heat exchanger to complete the refrigerant cycle. Now, the condensed water in the dephlegmator at state 9 flows down into the rectifying column along with rich solution and exchanges heat and mass with the vapour moving upwards. The hot solution that is now weak in refrigerant at state 6 flows into the solution heat exchanger where it is cooled to state 7 by preheating the rich solution. The weak, but high pressure solution at state 7 is then throttled in the solution expansion valve to state 8, from where it enters the absorber to complete its cycle.

As far as various energy flows out of the system are concerned, heat is supplied to the system at generator and evaporator, heat rejection takes place at absorber, condenser and dephlegmator and a small amount of work is supplied to the solution pump.

### 17.3. Principle of rectification column and dephlegmator

Figure 17.2 shows the schematic of the rectification system consisting of the generator, rectifying column and dephlegmator. As shown in the figure, strong solution from absorber enters at the rectification column, vapour rich in ammonia leaves at the top of the dephlegmator and weak solution leaves from the bottom of the generator. A heating medium supplies the required heat input  $Q_g$  to the generator and heat  $Q_d$  is rejected to the cooling water in the dephlegmator.



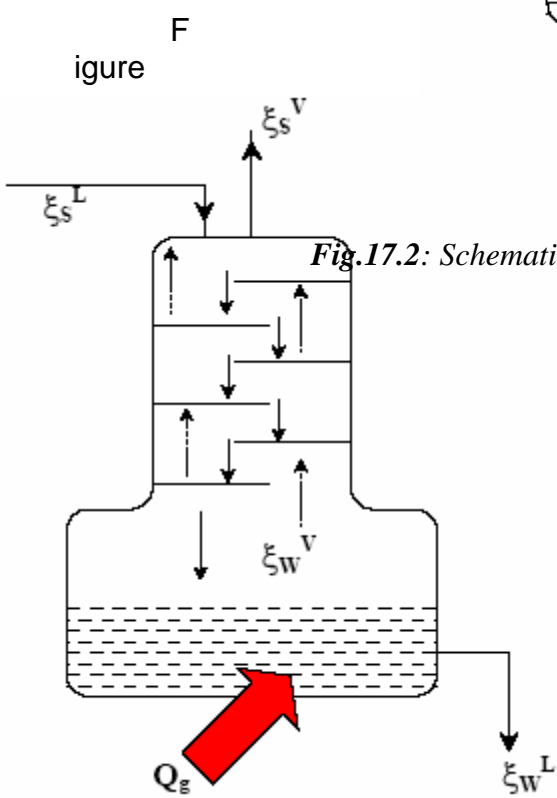
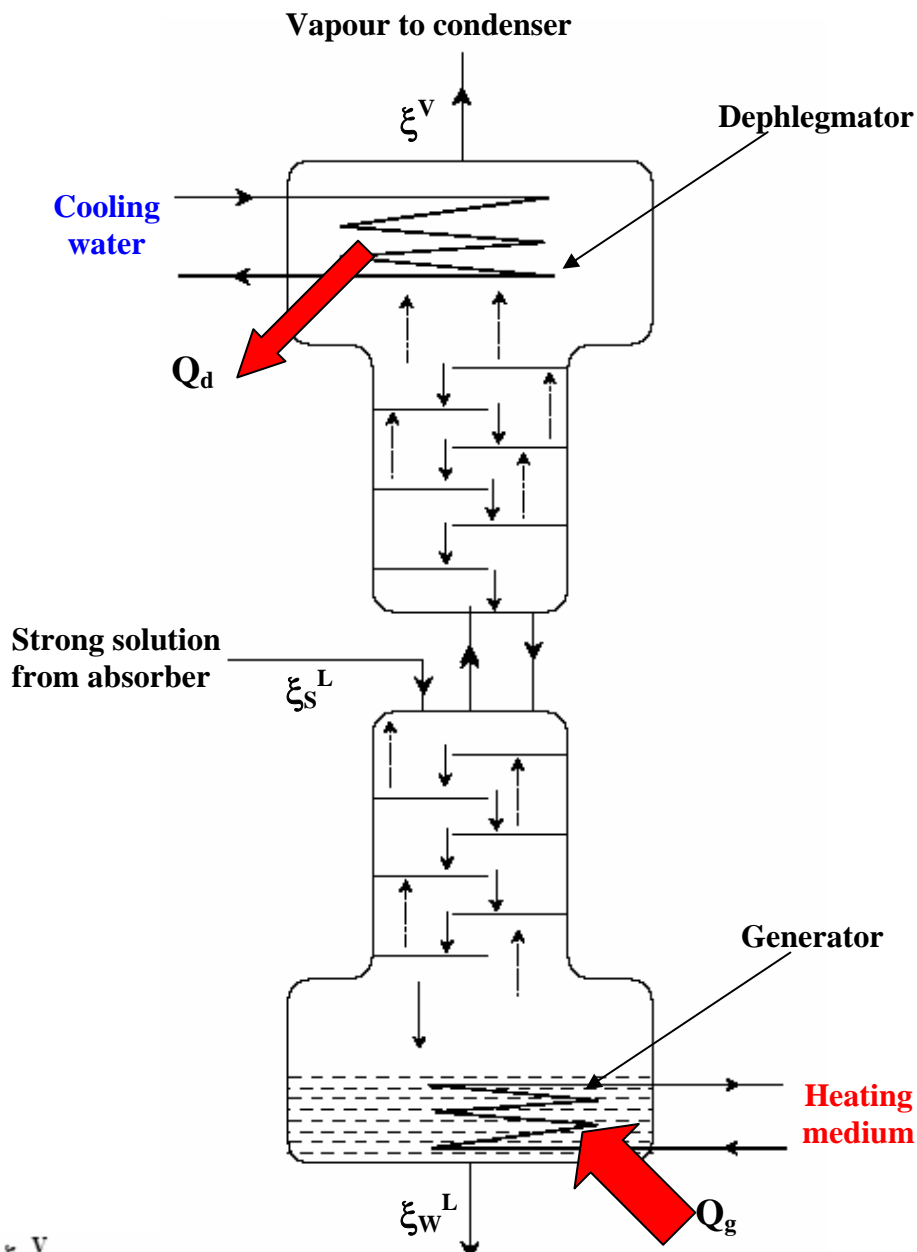


Fig.17.2: Schematic of the rectification column used in  $NH_3-H_2O$  systems

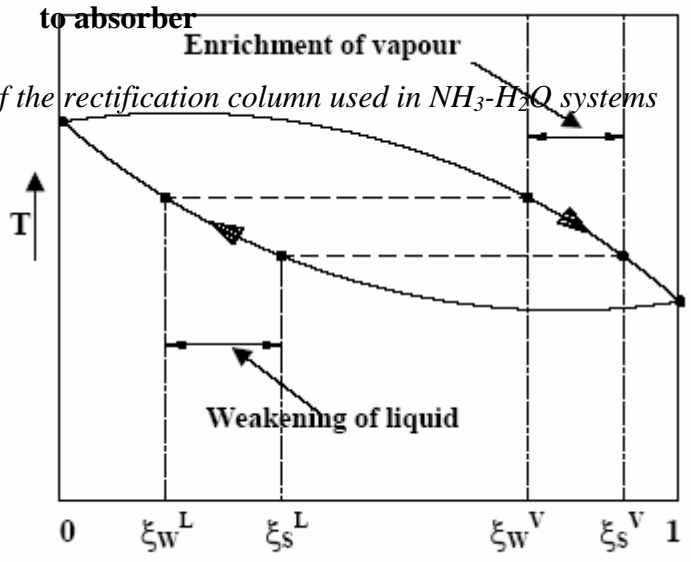


Fig.17.3: Rectification process in the generator

17.3 shows the schematic of the generator with lower portion of the rectification column and the process that takes place in this column on temperature-composition diagram. As shown, in this column the ascending vapour generated in the generator and initially at a mass fraction of  $\xi_w^V$  is enriched in ammonia to  $\xi_s^V$  as it exchanges heat and mass with the descending rich solution, which had an initial concentration of  $\xi_s^L$ . During this process the solution becomes weak as ammonia is transferred from liquid to vapour and water is transferred from vapour to liquid. In the limit with infinite residence time, the vapour leaves at mass fraction  $\xi_s^V$  that is in equilibrium with the strong solution. It can also be seen that during this process, due to heat transfer from the hot vapour to the liquid, the solution entering the generator section is preheated. This is beneficial as it reduces the required heat input in the generator.

Figure 17.4 shows the principle of dephlegmator (or reflux condenser) in which the ascending vapour is further enriched. At the top of the dephlegmator, heat is removed from the vapour so that a part of the vapour condenses (reflux). This reflux that is cooler, exchanges heat with the hotter vapour ascending in the column. During this process water vapour is transferred from the vapour to the liquid and ammonia is transferred from liquid to the vapour as shown in Fig. 17.4. As a result the vapour leaves the rectification column in almost pure ammonia form with a concentration of  $\xi^V$ .

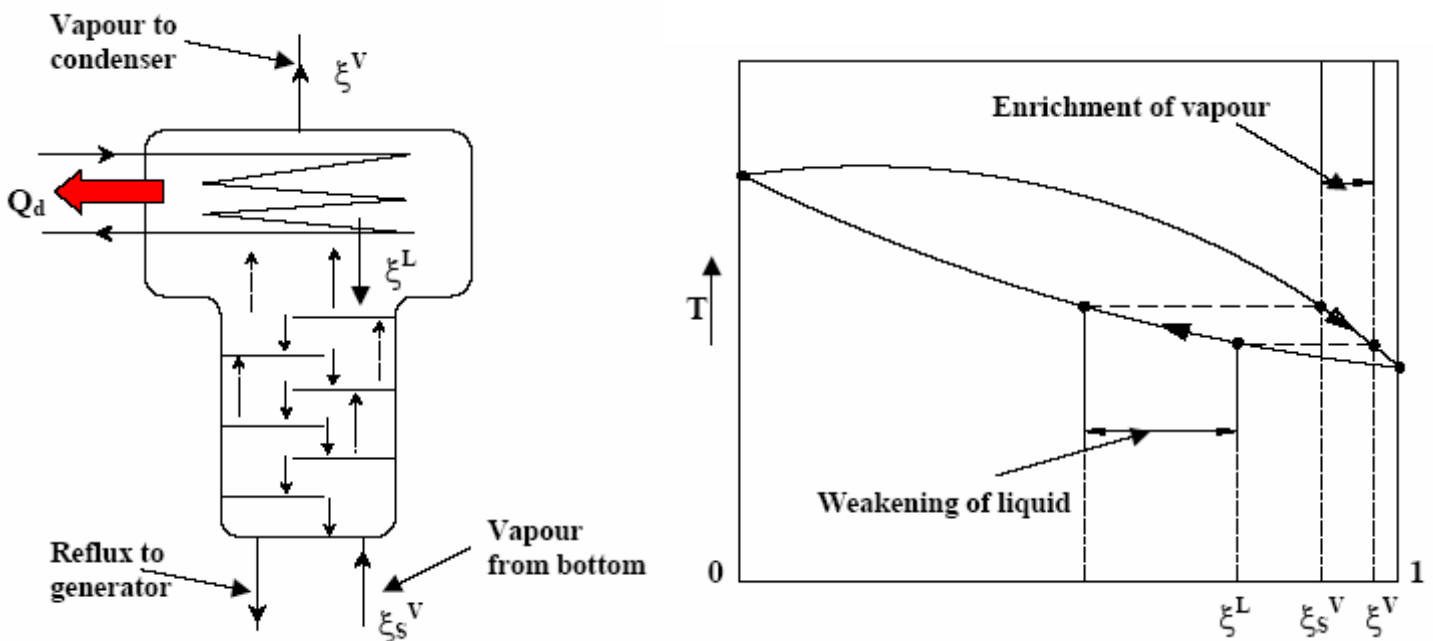


Fig.17.4: Principle of dephlegmator

## 17.4. Steady-flow analysis of the system

The analysis is carried out in a manner similar to water-lithium bromide system, i.e., by applying steady flow mass and energy balance to each component.

However, since the composition is defined on the basis of ammonia in the solution, the terms weak and strong solution concentrations have different meanings. In ammonia-water systems, strong solution means solution that is rich in ammonia, consequently, weak solution refers to solution that is weak in ammonia.

The circulation ratio  $\lambda$  is defined as the **ratio of weak solution to refrigerant flow rate**, i.e.,

$$\lambda = \frac{\dot{m}_{ws}}{\dot{m}} \Rightarrow \dot{m}_{ws} = \lambda \dot{m} \text{ and } \dot{m}_{ss} = (1 + \lambda) \dot{m} \quad (17.1)$$

By applying mass balance across the absorber and assuming the amount of water vapour in the refrigerant vapour at the exit of evaporator as negligible, the circulation ratio can be shown to be:

$$\lambda = \frac{1 - \xi_s}{\xi_s - \xi_w} \quad (17.2)$$

where  $\xi_s$  and  $\xi_w$  are the mass fractions of the strong and weak solutions leaving the absorber and entering the absorber, respectively.

Mass and energy balance equations for all the components are same as those of water-lithium bromide system, however, the thermal energy input to the generator will be different due to the heat transfer at the dephlegmator. Taking a control volume that includes entire rectifying column (generator + rectification column + dephlegmator) as shown in Fig.17.5, we can write the energy equation as:

$$Q_g - Q_d = \dot{m}_{10} h_{10} + \dot{m}_6 h_6 - \dot{m}_4 h_4 \quad (17.3)$$

writing the mass flow rates of strong (point 4) and weak (point 6) solutions in terms of refrigerant flow rate and mass fractions, we can write the above equation as:

$$Q_g - Q_d = \dot{m}[(h_{10} - h_4) + \lambda(h_6 - h_4)] \quad (17.4)$$

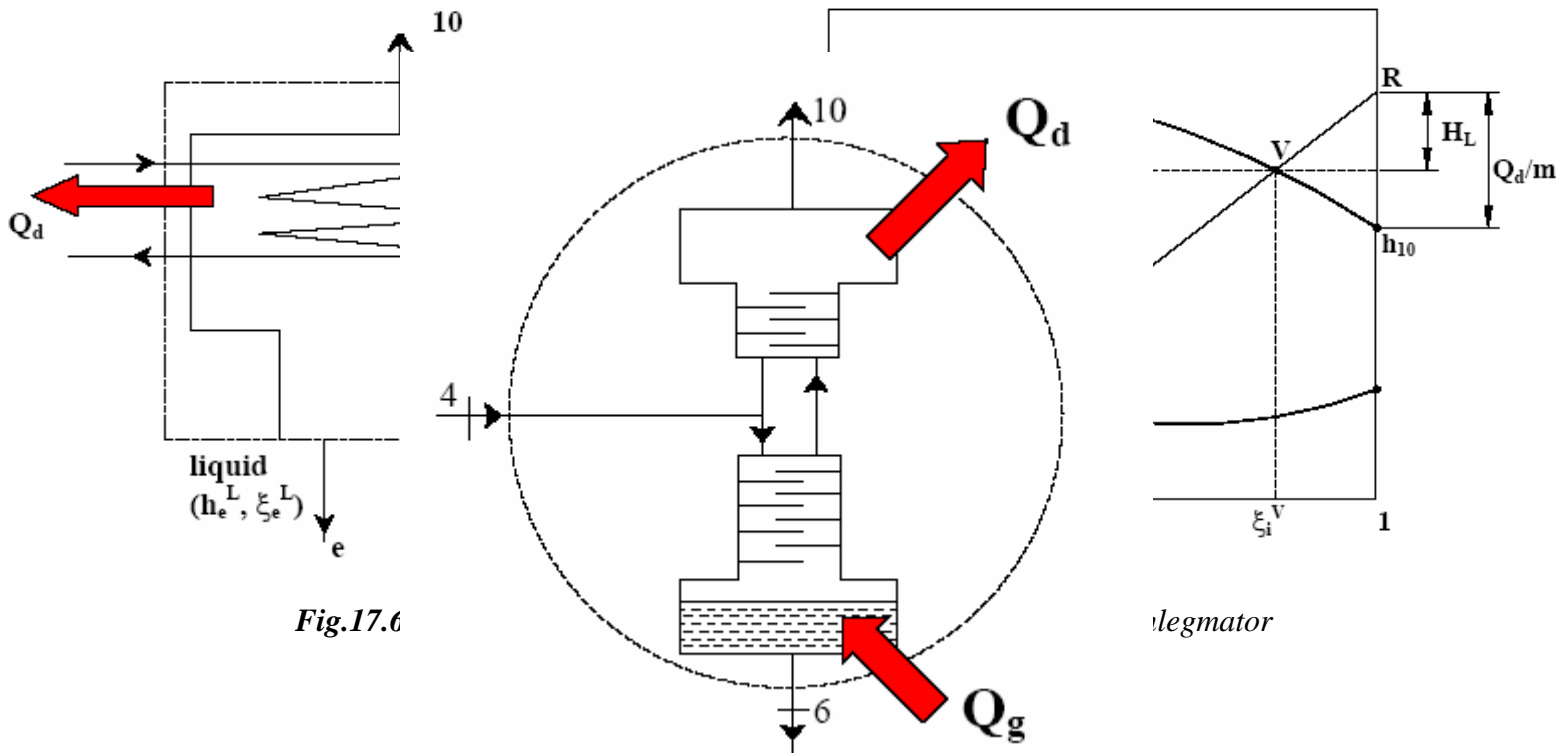


Fig.17.6

dephlegmator

Fig.17.5: Control volume for calculating heat input to the system

From the above expression  $Q_g - Q_d$  can be calculated, however, to find COP we need to know  $Q_g$ . This requires estimation of heat transferred in the dephlegmator,  $Q_d$ . This can be obtained by applying mass and energy balance across the dephlegmator section as shown in Fig.17.6. From these equations it can be shown that for **ideal rectification with the exit vapour being pure ammonia**, the heat transferred in the dephlegmator is given by:

$$\left( \frac{Q_d}{m} \right) = \left[ h_i^V - h_{10} + \left( \frac{1 - \xi_i^V}{\xi_i^V - \xi_e^L} \right) (h_i^V - h_e^L) \right] = (h_i^V - h_{10}) + H_L \quad (17.5)$$

$$H_L = \left( \frac{1 - \xi_i^V}{\xi_i^V - \xi_e^L} \right) (h_i^V - h_e^L) \quad (17.6)$$

The above equation is applicable at any section across the upper rectification column. If the process is plotted on enthalpy-composition diagram as shown in Fig.17.6, it can be easily seen that the ordinate of point R (called as Pole of the rectifier) is equal to  $\left( \frac{Q_d}{m} \right) + h_{10}$  as  $H_L$  is equal to  $H_L = \left( \frac{1 - \xi_i^V}{\xi_i^V - \xi_e^L} \right) (h_i^V - h_e^L)$ .

It should be noted that the line joining points L and V on enthalpy-composition diagram need not be an isotherm. In other words, points V and L need not be in equilibrium with each other, but they have to satisfy the mass and energy balance across the control volume.

For rectification to proceed in the column, it is essential that at every cross-section, the temperature of the vapour should be higher than that of the liquid. This is

possible only if the slope of the line passing through pole R is always steeper than the isotherm in the two-phase region passing through  $h_e^L$  and  $\xi_e^L$ . This can be ensured by placing the pole R at a sufficiently high level on the  $\xi = 1$  axis. This in turn fixes the minimum amount of reflux and the heat rejected at the dephlegmator. It is observed that for ammonia-water mixtures the condition that the vapour must always be warmer than the liquid is satisfied by drawing a straight line through R steeper than the isotherm passing through the strong solution feed point (point 4). This way the position of R is fixed and from this, the minimum amount of dephlegmator heat  $Q_{d,min}$  is determined. However, the actual dephlegmator heat  $Q_{d,act}$  will be larger than the minimum amount, and the ratio of minimum dephlegmator heat to actual dephlegmator heat is called as rectifier efficiency,  $\eta_R$  given by:

$$\eta_R = \frac{Q_{d,min}}{Q_{d,act}} \quad (17.7)$$

The rectifier efficiency depends on the design of contact surface used for the rectification column.

Sometimes, in the absence of required data, the COP is calculated by assuming that the dephlegmator heat is a certain percentage of generator heat (**usually 10 to 20 percent**).

## 17.5: Pumpless vapour absorption refrigeration systems

Conventional absorption refrigeration systems use a mechanical pump for pumping the solution from absorber pressure to generator pressure. However, there are also absorption refrigeration systems that do not require a mechanical pump. These systems offer several advantages over conventional systems such as:

- i. High reliability due to absence of moving parts
- ii. Very little maintenance
- iii. Systems require only low grade thermal energy, hence no need for any grid power
- iv. Silent operation

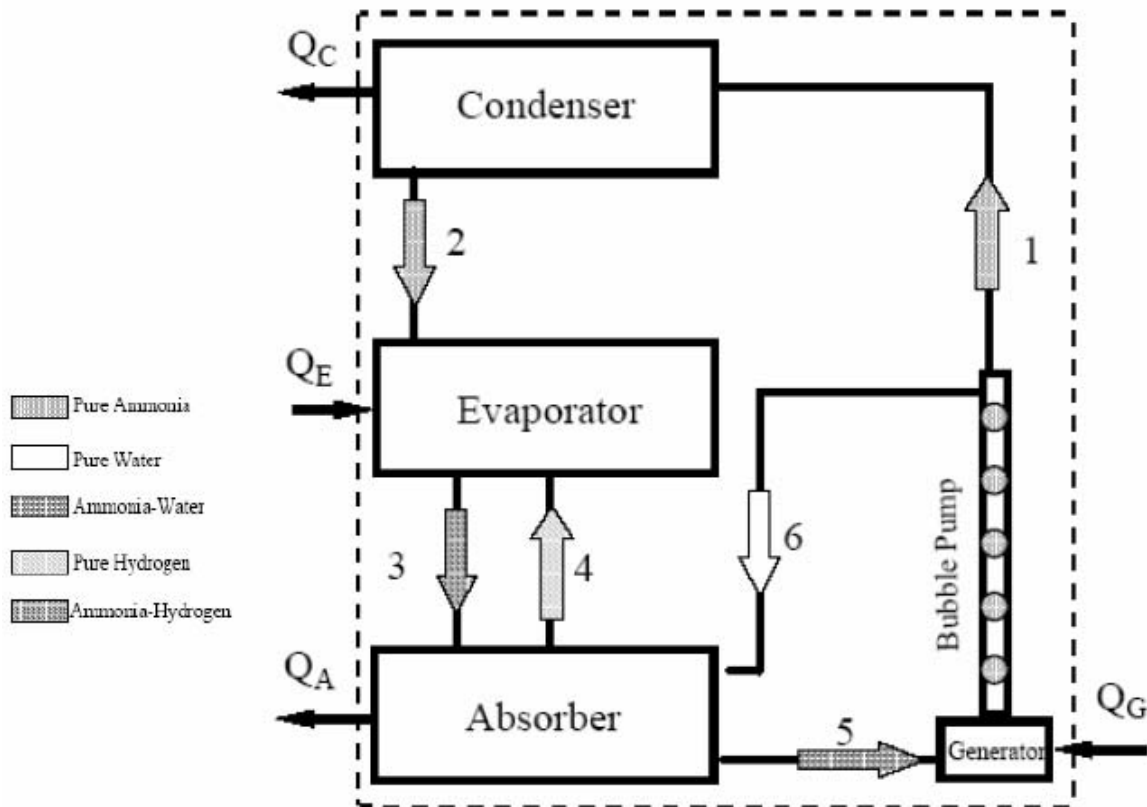
Due to the above advantages the pumpless systems find applications such as refrigerators for remote and rural areas, portable refrigerators, refrigerators for luxury hotel rooms etc.

Several pumpless systems using both water-lithium bromide and ammonia-water have been developed over the last many decades. However, among these the most popular and widely used system is the one known as Platen-Munters system or Triple Fluid Vapour Absorption Refrigeration System (TFVARS). As mentioned in the introduction, this system was developed by Platen and Munters of Sweden in 1930s. It uses ammonia as refrigerant and water as absorbent and hydrogen as an inert gas. Unlike conventional systems, the total pressure is constant throughout the Platen-Munters system, thus eliminating the need for mechanical pump or compressor. To allow the refrigerant (ammonia) **to evaporate at low temperatures in the evaporator**, a third inert gas (hydrogen) is introduced into the evaporator-absorber of the system. Thus even though the total pressure is constant throughout

the system, the partial pressure of ammonia in evaporator is much smaller than the total pressure due to the presence of hydrogen.

**For example:** if the total pressure of the system is 15 bar, then the condenser temperature will be  $38.7^{\circ}\text{C}$  (saturation temperature at 15 bar). If contribution of hydrogen to total pressure in the evaporator is 14 bar, then the partial pressure of ammonia in evaporator is 1 bar, hence ammonia can evaporate at  $-33^{\circ}\text{C}$  (saturation temperature at 1 bar), thus providing refrigeration effect at very low temperatures.

The liquid **ammonia in the evaporator cannot boil in the evaporator as its partial pressure is lower than the total pressure** (no vapour bubbles form). The **ammonia simply evaporates** into the hydrogen gas (just as liquid water evaporates into the atmosphere) as long as hydrogen gas is not saturated with ammonia. The ammonia vapour generated is carried away by the process of diffusion, hence Platen-Munters systems are also called as **diffusion-absorption systems**.

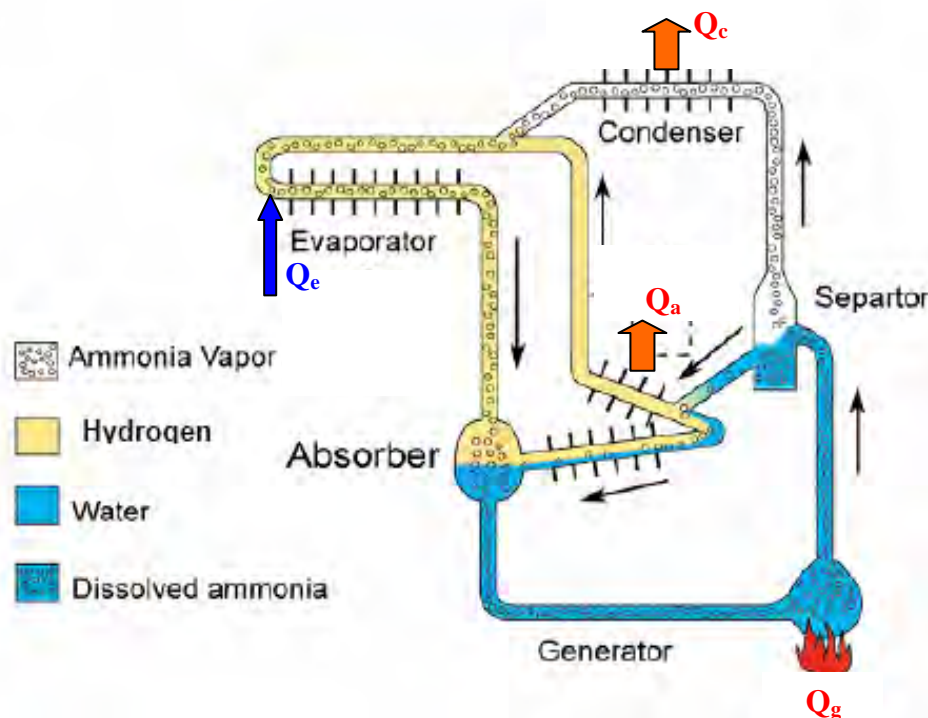


*Fig.17.8: Working principle of Platen-Munters system*

Figure 17.8 shows the schematic of a triple-fluid Platen-Munters system. Starting with the strong solution at the exit of the absorber (state 5), heat is supplied in the generator; ammonia vapour is generated as a result. The vapour generated moves up through the bubble pump due to buoyancy. As the vapour moves up it carries the weak solution to the top of the bubble pump. At the top, the weak solution and vapour are separated. The refrigerant vapour at state 1 flows into the condenser, where it condenses by rejecting heat to the heat sink (condensation takes place at high temperature as ammonia pressure is equal to the total pressure). The condensed liquid at state 2 flows into evaporator. As it enters into the evaporator its pressure is reduced to its partial pressure at evaporator temperature due to the presence of hydrogen gas in the evaporator. Due to the reduction in pressure, the ammonia evaporates by taking heat from the refrigerated space. The ammonia vapour diffuses into the hydrogen gas. Since the mixture of ammonia and hydrogen are cooler, it flows down into the absorber due to buoyancy. In the absorber, the ammonia vapour is absorbed by the weak solution coming from the bubble pump. Heat of absorption is rejected to the heat sink. Due to this, the temperature of hydrogen gas increases and it flows back into the evaporator due to buoyancy. Thus the circulation of fluids throughout the system is maintained due to buoyancy effects and gravity.

Due to the evaporation process (as against boiling in conventional systems) the temperature of the evaporating liquid changes along the length of the evaporator. **The coldest part is obtained at the end where hydrogen enters the evaporator as the partial of ammonia is least at this portion.** This effect can be used to provide two temperature sections in the evaporator for example: one for frozen food storage and the other for fresh food storage etc.

A **liquid seal** is required at the end of the condenser to prevent the entry of hydrogen gas into the condenser. Commercial Platen-Munters systems are made of all steel with welded joints. Additives are added to minimize corrosion and rust formation and also to improve absorption. Since there are no flared joints and if the quality of the welding is good, then these systems become extremely rugged and reliable. The Platen-Munters systems offer low COPs (of the order of 0.2) due to energy requirement in the bubble pump and also due to losses in the evaporator because of the presence of hydrogen gas. In addition, since the circulation of fluids inside the system is due to buoyancy and gravity, the heat and mass transfer coefficients are relatively small, further reducing the efficiency. However, these systems are available with a wide variety of heat sources such as electrical heaters (in small hotel room systems), natural gas or LPG gas, hot oils etc. Figure 17.9 shows the schematic of the refrigeration system of a small commercial Platen-Munters system.



*Fig.17.9: Refrigeration circuit of a small diffusion-absorption (Platen-Munters) system*

It is interesting to know that Albert Einstein along with Leo Szilard had obtained a US patent for a pumpless absorption refrigeration system in 1930. The principle of operation of this system is entirely different from that of Platen-Munters system. In Einstein's system, butane is used as the refrigerant, while ammonia is used as pressure equalizing fluid in evaporator. Water is used as the absorbent for the pressure equalizing fluid. However, unlike Platen-Munter's system, Einstein's system has not been commercialized. Recently attempts have been made to revive Einstein's cycle.

## 17.6: Solar energy driven sorption systems



In principle, solar energy can be used to drive any type of refrigeration system: compression or absorption. However, in most of the cases, the direct utilization of solar thermal energy for running refrigeration systems is more efficient. Thus solar energy based heat operated systems are attractive. Again solar energy can be used to run a conventional absorption system with solution pump or a pumpless absorption or adsorption system.

Solar energy driven adsorption systems that use a solid adsorbent in place of a liquid absorbent offer certain advantages. The solid sorption systems also known as dry absorption systems do not have a solution circuit as the vapour/gas is directly absorbed and desorbed by a solid. Notable among the dry absorption types are the systems based on **water-zeolites/silica gel, methanol-activated carbon, ammonia-calcium chloride, sulphur dioxide-sulphites, carbon dioxide-carbonates** and **hydrogen-metal hydrides**. However, some practical design problems such as: smaller specific power outputs, poor heat and mass transfer characteristics of the solid absorbents, unwanted side reactions, undesired decomposition of reacting materials, swelling of solid material and corrosion of the structural materials due to the nature of the reacting materials/reactions hamper the development of solid sorption systems on commercial scale. Several successful attempts have been made to build refrigeration systems that run on solar energy only. However, several practical problems related to their cost, performance and reliability hamper the wide-spread use of solar energy driven refrigeration systems.

## 17.7: Comparison between compression and absorption refrigeration systems

Table 17.1 shows a comparison between compression and absorption refrigeration systems.

<b>Compression systems</b>	<b>Absorption systems</b>
Work operated	Heat operated
High COP	Low COP (currently maximum $\approx 1.4$ )
Performance (COP and capacity) very sensitive to evaporator temperatures	Performance not very sensitive to evaporator temperatures
System COP reduces considerably at part loads	COP does not reduce significantly with load
Liquid at the exit of evaporator may damage compressor	Presence of liquid at evaporator exit is not a serious problem
Performance is sensitive to evaporator superheat	Evaporator superheat is not very important
Many moving parts	Very few moving parts
Regular maintenance required	Very low maintenance required
Higher noise and vibration	Less noise and vibration
Small systems are compact and large systems are bulky	Small systems are bulky and large systems are compact
Economical when electricity is available	Economical where low-cost fuels or waste heat is available

**Table 17.1:** Comparison between compression and absorption systems

## Questions and answers:

1. In an ammonia-water system a rectification column is used mainly to:

- a) To improve the COP of the system
- b) To reduce the operating pressures
- c) To minimize the concentration of water in refrigeration circuit
- d) All of the above

**Ans.: c)**

2. In a reflux condenser:

- a) Heat is extracted so that the vapour leaving is rich in ammonia
- b) Heat is supplied so that the vapour leaving is rich in ammonia
- c) Heat is extracted so that the vapour leaving is rich in water
- d) Heat is supplied so that the vapour leaving is rich in ammonia

**Ans.: a)**

3. Due to the requirement of rectification:

- a) The required generator pressure increases
- b) The required generator temperature increases
- c) The required generator heat input increases
- d) All of the above

**Ans.: c)**

4. In pumpless vapour absorption refrigeration systems:

- a) The evaporation process is non-isothermal
- b) The system pressure is almost same everywhere
- c) A pressure equalizing fluid is required to increase condenser pressure
- d) A pressure equalizing fluid is required to increase evaporator pressure

**Ans.: a), b) and d)**

5. Which of the following statements regarding pumpless systems are TRUE:

- a) Pumpless systems can use a wide variety of heat sources
- b) Pumpless systems are silent, reliable and rugged
- c) Pumpless systems offer high COPs
- d) Pumpless systems operate at very low pressures

**Ans.: a) and b)**

6. Compared to compression systems, the performance of absorption systems:

- a) Is very sensitive to evaporator temperature
- b) Is not sensitive to load variations
- c) Does not depend very much on evaporator superheat
- d) All of the above

**Ans.: b) and c)**

7. Compared to compression systems, absorption systems:

- a) Contain very few moving parts
- b) Require regular maintenance
- c) Offer less noise and vibration
- d) Are compact for large capacities

**Ans.: a), c) and d)**

8. A vapour absorption refrigeration system based on ammonia-water (Figure 17.1) has refrigeration capacity of **100 TR**. The various state properties of the system shown below are given in the table. Taking the heat rejection rate in the reflux condenser ( $Q_d$ ) as **88 kW**, find a) The mass flow rates of solution through the evaporator, strong solution and weak solution; b) Enthalpy values not specified in the table and c) Heat transfer rates at condenser, absorber and generator and solution pump work d) System COP

State point	P, bar	T, °C	Concentration (X), kg of NH <sub>3</sub> /kg of solution	Enthalpy, kJ/kg
1	2.04	13.9	0.996	
2	2.04	26.1	0.408	-58.2
3	13.61	26.1	0.408	-56.8
4	13.61	93.3	0.408	253.6
6	13.61	115.6	0.298	369.9
7	13.61	36.1	0.298	
8	2.04	36.1	0.298	
10	13.61	54.4	0.996	1512.1
11	13.61	36.1	0.996	344.3
12	13.61	30.0	0.996	318.7
13	2.04	-17.8	0.996	
14	2.04	4.4	0.996	1442.3

**Ans.:**

a) Mass flow rate through evaporator,  $m_1$  is given by:

$$m_1 = \left( \frac{Q_e}{h_{14} - h_{13}} \right) = \left( \frac{Q_e}{h_{14} - h_{12}} \right) = \left( \frac{3.517 \times 100}{1442.3 - 318.7} \right) = 0.313 \text{ kg/s} \quad (\text{Ans.})$$

Circulation ratio  $\lambda$  is given by:

$$\lambda = \left( \frac{m_{ws}}{m_1} \right) = \left( \frac{\xi_{10} - \xi_7}{\xi_7 - \xi_8} \right) = 5.345$$

Therefore, mass flow rate of weak solution,  $m_{ws} = m_1 \times \lambda = 1.673 \text{ kg/s}$  (Ans.)

mass flow rate of strong solution,  $m_{ss} = m_1 \times (1 + \lambda) = 1.986 \text{ kg/s}$  (Ans.)

b) State points 1, 7, 8 and 13:

From energy balance across Heat Exchanger -I;

$$(h_{11} - h_{12}) = (h_1 - h_{14}) \Rightarrow h_1 = h_{14} + (h_{11} - h_{12}) = 1467.9 \text{ kJ/kg} \quad (\text{Ans.})$$

From energy balance across solution heat exchanger:

$$m_{ss}(h_4 - h_3) = m_{ws}(h_6 - h_7) \Rightarrow h_7 = 1.43 \text{ kJ/kg} \quad (\text{Ans.})$$

Since expansion through expansion valves is isenthalpic,

$$h_8 = h_7 = 1.43 \text{ kJ/kg} \quad (\text{Ans.})$$

$$h_{12} = h_{13} = 318.7 \text{ kJ/kg} \quad (\text{Ans.})$$

c) From energy balance:

$$\text{Heat transfer rate at condenser, } Q_c = m_{10}(h_{10} - h_{11}) = 365.5 \text{ kW} \quad (\text{Ans.})$$

$$\text{Heat transfer rate at absorber, } Q_a = m_1 h_1 + m_8 h_8 - m_2 h_2 = 577.4 \text{ kW} \quad (\text{Ans.})$$

$$\text{Heat transfer rate at generator, } Q_g = m_{10} h_{10} + m_6 h_6 + Q_d - m_4 h_4 = 676.5 \text{ kW} \quad (\text{Ans.})$$

$$\text{Power input to pump, } W_p = m_2(h_3 - h_2) = 2.78 \text{ kW} \quad (\text{Ans.})$$

System COP is given by:

$$\text{COP} = \left( \frac{Q_e}{Q_g + W_p} \right) = \left( \frac{351.7}{676.5 + 2.78} \right) = 0.518 \quad (\text{Ans.})$$

### Comments:

1. It can be seen that compared to heat input to the system at the generator, the work input to the system is almost negligible (less than 0.5 percent)
2. The system COP is reduced as the required heat input to the generator increases due to heat rejection at dephlegmator. However, this cannot be avoided as rectification of the vapour is required. However, it is possible to analyze the rectification process to minimize the heat rejection at the dephlegmator

# Lesson

## 18

# Refrigeration System Components: Compressors

## The objectives of this lesson are to:

1. Discuss basic components of a vapour compression refrigeration system (*Section 18.1*)
2. Present classification of refrigerant compressors based on working principle and based on the arrangement of compressor motor or external drive (*Section 18.2.1*)
3. Describe the working principle of reciprocating compressors (*Section 18.3*)
4. Discuss the performance aspects of ideal reciprocating compressors with and without clearance (*Section 18.3.1*)

At the end of the lesson, the student should be able to:

1. List important components of a vapour compression refrigeration system
2. Classify refrigerant compressors based on their working principle and based on the arrangement of compressor motor/external drive
3. Enumerate salient features of positive displacement type compressors, dynamic compressors, open and hermetic compressors
4. Draw the schematic of a reciprocating compressor and explain its working principle
5. Define an ideal reciprocating compressor without clearance using pressure-volume and pressure-crank angle diagrams
6. Calculate the required displacement rate and power input of an ideal compressor without clearance
7. Define an ideal reciprocating compressor with clearance using pressure-volume and pressure-crank angle diagrams
8. Calculate the volumetric efficiency and power input of an ideal compressor with clearance, and
9. Discuss the effects of compression ratio and index of compression on the volumetric efficiency of a reciprocating compressor with clearance

### 18.1. Introduction

A typical refrigeration system consists of several basic components such as compressors, condensers, expansion devices, evaporators, in addition to several accessories such as controls, filters, driers, oil separators etc. For efficient operation of the refrigeration system, it is essential that there be a proper matching between various components. Before analyzing the balanced performance of the complete system, it is essential to study the design and performance characteristics of individual components. Except in special applications, the refrigeration system components are standard components manufactured by industries specializing in individual components. Generally for large systems, depending upon the design specifications, components are selected from the manufacturers' catalogs and are assembled at site. Even though most of the components are standard off-the-shelf items, sometimes components such as evaporator may be made to order. Small capacity refrigeration systems such as refrigerators, room and package air conditioners,

water coolers are available as complete systems. In this case the manufacturer himself designs or selects the system components, assembles them at the factory, tests them for performance and then sells the complete system as a unit.

## 18.2. Compressors

A compressor is the most important and often the costliest component (typically 30 to 40 percent of total cost) of any vapour compression refrigeration system (VCRS). The function of a compressor in a VCRS is to continuously draw the refrigerant vapour from the evaporator, so that a low pressure and low temperature can be maintained in the evaporator at which the refrigerant can boil extracting heat from the refrigerated space. The compressor then has to raise the pressure of the refrigerant to a level at which it can condense by rejecting heat to the cooling medium in the condenser.

### 18.2.1. Classification of compressors

Compressors used in refrigeration systems can be classified in several ways:

#### a) Based on the working principle:

- i. Positive displacement type
- ii. Roto-dynamic type

In positive displacement type compressors, compression is achieved by trapping a refrigerant vapour into an enclosed space and then reducing its volume. Since a fixed amount of refrigerant is trapped each time, its pressure rises as its volume is reduced. When the pressure rises to a level that is slightly higher than the condensing pressure, then it is expelled from the enclosed space and a fresh charge of low-pressure refrigerant is drawn in and the cycle continues. Since the flow of refrigerant to the compressor is not steady, the positive displacement type compressor is a *pulsating flow device*. However, since the operating speeds are normally very high the flow appears to be almost steady on macroscopic time scale. Since the flow is pulsating on a microscopic time scale, positive displacement type compressors are prone to high wear, vibration and noise level. Depending upon the construction, positive displacement type compressors used in refrigeration and air conditioning can be classified into:

- i. Reciprocating type
- ii. Rotary type with sliding vanes (rolling piston type or multiple vane type)
- iii. Rotary screw type (single screw or twin-screw type)
- iv. Orbital compressors, and
- v. Acoustic compressors

In roto-dynamic compressors, the pressure rise of refrigerant is achieved by imparting kinetic energy to a steadily flowing stream of refrigerant by a rotating mechanical element and then converting into pressure as the refrigerant flows through a diverging passage. Unlike positive displacement type, the roto-dynamic type compressors are steady flow devices, hence are subjected to less wear and

vibration. Depending upon the construction, roto-dynamic type compressors can be classified into:

- i. Radial flow type, or
- ii. Axial flow type

Centrifugal compressors (also known as turbo-compressors) are radial flow type, roto-dynamic compressors. These compressors are widely used in large capacity refrigeration and air conditioning systems. Axial flow compressors are normally used in gas liquefaction applications.

b) Based on arrangement of compressor motor or external drive:

- i. Open type
- ii. Hermetic (or sealed) type
- iii. Semi-hermetic (or semi-sealed) type

In open type compressors the rotating shaft of the compressor extends through a seal in the crankcase for an external drive. The external drive may be an electrical motor or an engine (e.g. diesel engine). The compressor may be belt driven or gear driven. Open type compressors are normally used in medium to large capacity refrigeration system for all refrigerants and for ammonia (due to its incompatibility with hermetic motor materials). Open type compressors are characterized by high efficiency, flexibility, better compressor cooling and serviceability. However, since the shaft has to extend through the seal, refrigerant leakage from the system cannot be eliminated completely. Hence refrigeration systems using open type compressors require a refrigerant reservoir to take care of the refrigerant leakage for some time, and then regular maintenance for charging the system with refrigerant, changing of seals, gaskets etc.

In hermetic compressors, the motor and the compressor are enclosed in the same housing to prevent refrigerant leakage. The housing has welded connections for refrigerant inlet and outlet and for power input socket. As a result of this, there is virtually no possibility of refrigerant leakage from the compressor. All motors reject a part of the power supplied to it due to eddy currents and friction, that is, inefficiencies. Similarly the compressor also gets heated-up due to friction and also due to temperature rise of the vapor during compression. In Open type, both the compressor and the motor normally reject heat to the surrounding air for efficient operation. In hermetic compressors heat cannot be rejected to the surrounding air since both are enclosed in a shell. Hence, the cold suction gas is made to flow over the motor and the compressor before entering the compressor. This keeps the motor cool. The motor winding is in direct contact with the refrigerant hence only those refrigerants, which have high dielectric strength, can be used in hermetic compressors. The cooling rate depends upon the flow rate of the refrigerant, its temperature and the thermal properties of the refrigerant. If flow rate is not sufficient and/or if the temperature is not low enough the insulation on the winding of the motor can burn out and short-circuiting may occur. Hence, hermetically sealed compressors give satisfactory and safe performance over a very narrow range of design temperature and should not be used for off-design conditions.



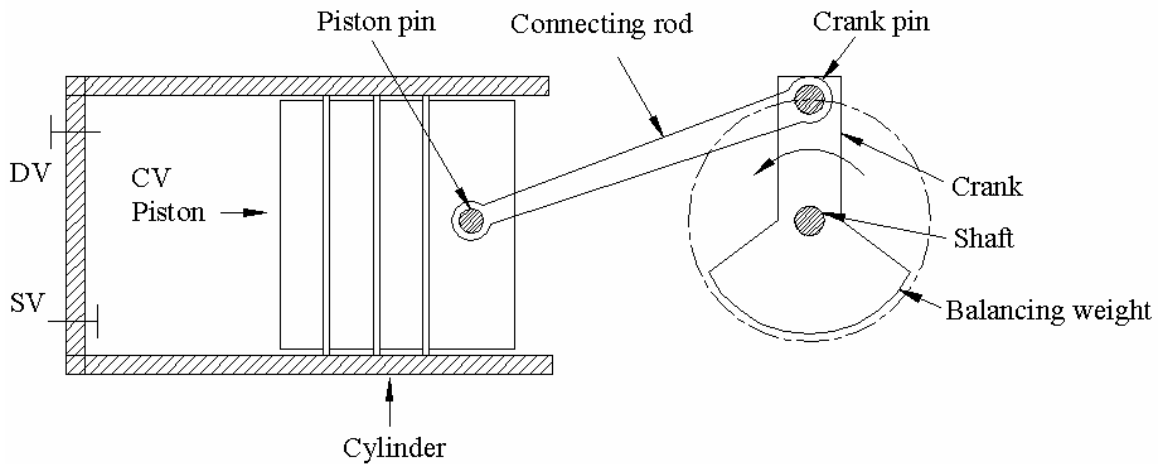
The COP of the hermetic compressor based systems is lower than that of the open compressor based systems since a part of the refrigeration effect is lost in cooling the motor and the compressor. However, hermetic compressors are almost universally used in small systems such as domestic refrigerators, water coolers, air conditioners etc, where efficiency is not as important as customer convenience (due to absence of continuous maintenance). In addition to this, the use of hermetic compressors is ideal in systems, which use capillary tubes as expansion devices and are critically charged systems. Hermetic compressors are normally not serviceable. They are not very flexible as it is difficult to vary their speed to control the cooling capacity.

In some (usually larger) hermetic units, the cylinder head is usually removable so that the valves and the piston can be serviced. This type of unit is called a semi-hermetic (or semi-sealed) compressor.

### 18.3. Reciprocating compressors

Reciprocating compressor is the workhorse of the refrigeration and air conditioning industry. It is the most widely used compressor with cooling capacities ranging from a few Watts to hundreds of kilowatts. Modern day reciprocating compressors are high speed ( $\approx 3000$  to  $3600$  rpm), single acting, single or multi-cylinder (upto 16 cylinders) type.

Figure 18.1 shows the schematic of a reciprocating compressor. Reciprocating compressors consist of a piston moving back and forth in a cylinder, with suction and discharge valves to achieve suction and compression of the refrigerant vapor. Its construction and working are somewhat similar to a two-stroke engine, as suction and compression of the refrigerant vapor are completed in one revolution of the crank. The suction side of the compressor is connected to the exit of the evaporator, while the discharge side of the compressor is connected to



**Fig 18.1:** Schematic of a reciprocating compressor

the condenser inlet. The suction (inlet) and the discharge (outlet) valves open and close due to pressure differences between the cylinder and inlet or outlet manifolds respectively. The pressure in the inlet manifold is equal to or slightly less than the evaporator pressure. Similarly the pressure in the outlet manifold is equal to or slightly greater than the condenser pressure. The purpose of the manifolds is to provide stable inlet and outlet pressures for the smooth operation of the valves and also provide a space for mounting the valves.

The valves used are of reed or plate type, which are either floating or clamped. Usually, backstops are provided to limit the valve displacement and springs may be provided for smooth return after opening or closing. The piston speed is decided by valve type. Too high a speed will give excessive vapor velocities that will decrease the volumetric efficiency and the throttling loss will decrease the compression efficiency.

### 18.3.1. Performance of reciprocating compressors

For a given evaporator and condenser pressures, the important performance parameters of a refrigerant compressor are:

- The mass flow rate ( $m$ ) of the compressor for a given displacement rate
- Power consumption of the compressor ( $W_c$ )
- Temperature of the refrigerant at compressor exit,  $T_d$ , and
- Performance under part load conditions

The mass flow rate decides the refrigeration capacity of the system and for a given compressor inlet condition, it depends on the volumetric efficiency of the compressor. The volumetric efficiency,  $\eta_v$  is defined as the ratio of volumetric flow rate of refrigerant to the maximum possible volumetric flow rate, which is equal to the compressor displacement rate, i.e.,

$$\eta_v = \frac{\text{Volumetric flow rate}}{\text{Compressor Displacement rate}} = \frac{\dot{m} \cdot v_e}{\dot{V}_{sw}} \quad (18.1)$$

where  $\dot{m}$  and  $\dot{V}_{sw}$  are the mass flow rate of refrigerant (kg/s) and compressor displacement rate (m<sup>3</sup>/s) respectively, and  $v_i$  is the specific volume (m<sup>3</sup>/kg) of the refrigerant at compressor inlet.

For a given evaporator and condenser temperatures, one can also use the volumetric refrigeration capacity (kW/m<sup>3</sup>) to indicate the volumetric efficiency of the compressor. The actual volumetric efficiency (or volumetric capacity) of the compressor depends on the operating conditions and the design of the compressor.

The power consumption (kW) or alternately the power input per unit refrigeration capacity (kW/kW) depends on the compressor efficiency ( $\eta_c$ ), efficiency of the mechanical drive ( $\eta_{mech}$ ) and the motor efficiency ( $\eta_{motor}$ ). For a refrigerant compressor, the power input ( $W_c$ ) is given by:

$$W_c = \frac{W_{ideal}}{\eta_c \eta_{mech} \eta_{motor}} \quad (18.2)$$

where  $W_{ideal}$  is the power input to an ideal compressor.

The temperature at the exit of the compressor (discharge compressor) depends on the type of refrigerant used and the type of compressor cooling. This parameter has a bearing on the life of the compressor.

The performance of the compressor under part load conditions depends on the type and design of the compressor.

#### a) Ideal reciprocating compressor:

An ideal reciprocating compressor is one in which:

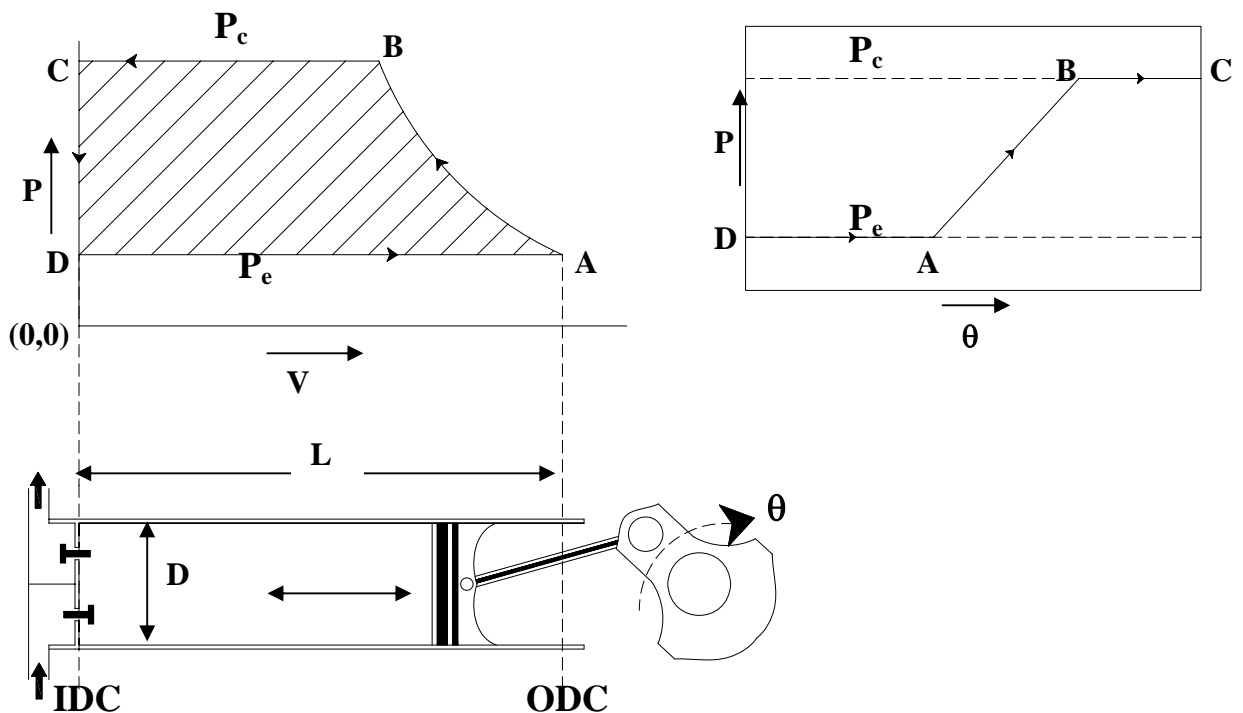
- i. The clearance volume is zero, i.e., at the end of discharge process, the volume of refrigerant inside the cylinder is zero.
- ii. No pressure drops during suction and compression
- iii. Suction, compression and discharge are reversible and adiabatic

Figure 180.2 shows the schematic of an ideal compression process on pressure-volume and pressure-crank angle ( $\theta$ ) diagrams. As shown in the figures, the cycle of operations consists of:

Process D-A: This is an isobaric suction process, during which the piston moves from the Inner Dead Centre (IDC) to the Outer Dead Centre (ODC). The suction valve remains open during this process and refrigerant at a constant pressure  $P_e$  flows into the cylinder.

Process A-B: This is an isentropic compression process. During this process, the piston moves from ODC towards IDC. Both the suction and discharge valves remain closed during the process and the pressure of refrigerant increases from  $P_e$  to  $P_c$ .

Process B-C: This is an isobaric discharge process. During this process, the suction valve remains closed and the discharge valve opens. Refrigerant at a constant  $P_c$  is expelled from the compressor as the piston moves to IDC.



**Fig.18.2.** Ideal reciprocating compressor on  $P$ - $V$  and  $P$ - $\theta$  diagrams

Since the clearance volume is zero for an ideal compressor, no gas is left in the compressor at the end of the discharge stroke, as a result the suction process  $D$ - $A$  starts as soon as the piston starts moving again towards ODC. The volumetric flow rate of refrigerant at suction conditions is equal to the compressor displacement rate hence, the volumetric efficiency of the ideal compressor is 100 percent. The mass flow rate of refrigerant of an ideal compressor is given by:

$$\dot{m} = \frac{\dot{V}_{sw}}{v_e} \quad (18.3)$$

Thus for a given refrigeration capacity, the required size of the compressor will be minimum if the compressor behaves as an ideal compressor.

The swept volume  $\dot{V}_{sw}$  of the compressor is given by:

$$\dot{V}_{sw} = nN \frac{\pi D^2}{4} L \quad (18.4)$$

where  $n$  = Number of cylinders

$N$  = Rotational speed of compressor, revolutions per second

$D$  = Bore of the cylinder, m

$L$  = Stroke length, m

Work input to the ideal compressor:

The total work input to the compressor in one cycle is given by:

$$W_{id} = W_{D-A} + W_{A-B} + W_{B-C} \quad (18.5)$$

Where,

$W_{D-A}$  = Work done by the refrigerant on the piston during process D-A  
= Area under line D-A on P-V diagram =  $-P_e \cdot V_A$

$W_{A-B}$  = Work done by the piston on refrigerant during compression A-B  
= Area under the curve A-B on P-V diagram =  $\int_{V_A}^{V_B} P \cdot dV$

$W_{B-C}$  = Work done by the piston on the refrigerant during discharge B-C  
= Area under line B-C =  $P_c \cdot V_B$

$$\therefore W_{id} = -P_e \cdot V_A + \int_{V_A}^{V_B} P \cdot dV + P_c \cdot V_B = \text{Area A-B-C-D on P-V diagram} = \int_{P_e}^{P_c} V \cdot dP$$

Thus the work input to the ideal compressor per cycle is equal to the area of the cycle on P-V diagram.

The specific work input,  $w_{id}$  (kJ/kg) to the ideal compressor is given by:

$$w_{id} = \frac{W_{id}}{M_r} = \int_{P_e}^{P_c} v \cdot dP \quad (18.6)$$

where  $M_r$  is the mass of refrigerant compressed in one cycle and  $v$  is the specific volume of the refrigerant.

The power input to the compressor  $W_c$  is given by:

$$W_c = \dot{m} w_{id} = \frac{\dot{V}_{sw}}{V_e} \int_{P_e}^{P_c} v \cdot dP \quad (18.7)$$

The mean effective pressure (mep) for the ideal compressor is given by:

$$mep = \frac{W_{id}}{\dot{V}_{SW}} = \frac{1}{V_e} \int_{P_e}^{P_c} v \cdot dP \quad (18.8)$$

The concept of *mean effective pressure* is useful for real compressors as the power input to the compressor is a product of mep and the swept volume rate.

Thus the power input to the compressor and its mean effective pressure can be obtained from the above equation if the relation between  $v$  and  $P$  during the compression process A-B is known. The above equation is valid for both isentropic and non-isentropic compression processes, however, the compression process must be reversible, as the path of the process should be known for the integration to be performed.

For the isentropic process,  $Pv^k = \text{constant}$ , hence the specific work of compression  $w_{id}$  can be obtained by integration, and it can be shown to be equal to:

$$w_{id} = \int_{P_e}^{P_c} v \cdot dP = P_e v_e \left( \frac{k}{k-1} \right) \left[ \left( \frac{P_c}{P_e} \right)^{\frac{k-1}{k}} - 1 \right] \quad (18.9)$$

In the above equation,  $k$  is the index of isentropic compression. If the refrigerant behaves as an ideal gas, then  $k = \gamma$ . In general, the value of  $k$  for refrigerants varies from point to point, and if its value is not known, then an approximate value of it can be obtained from the values of pressure and specific volume at the suction and discharge states as  $k \approx \frac{\ln(P_c / P_e)}{\ln(v_e / v_c)}$ .

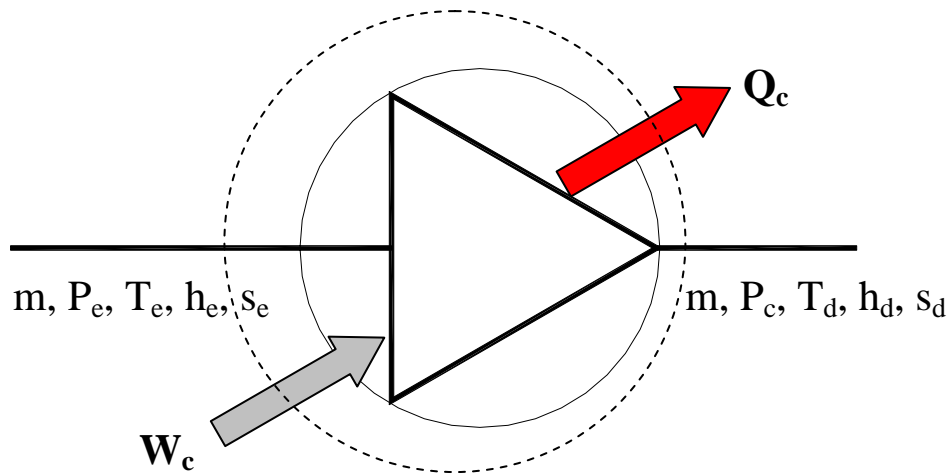
The work of compression for the ideal compressor can also be obtained by applying energy balance across the compressor, Fig.18.3. Since the process is assumed to be reversible and adiabatic and if we assume changes in potential and kinetic energy to be negligible, then from energy balance across the compressor:

$$w_{id} = \frac{W_c}{m} = (h_c - h_e) \quad (18.10)$$

The above expression can also be obtained from the thermodynamic relation:

$$\begin{aligned} Tds = dh - vdP &\Rightarrow dh = vdP \quad (\because ds=0 \text{ for isentropic process}) \\ \therefore w_{id} &= \int_{P_e}^{P_c} vdP = \int_{P_e}^{P_c} dh = (h_d - h_e) \end{aligned} \quad (18.11)$$

The above expression is valid only for reversible, adiabatic compression.



**Fig.18.3.** Energy balance across a steady flow compressor

b) Ideal compressor with clearance:

In actual compressors, a small clearance is left between the cylinder head and piston to accommodate the valves and to take care of thermal expansion and machining tolerances. As a thumb rule, the clearance  $C$  in millimetres is given by:

$$C = (0.005L + 0.5) \text{ mm, where } L \text{ is stroke length in mm} \quad (18.12)$$

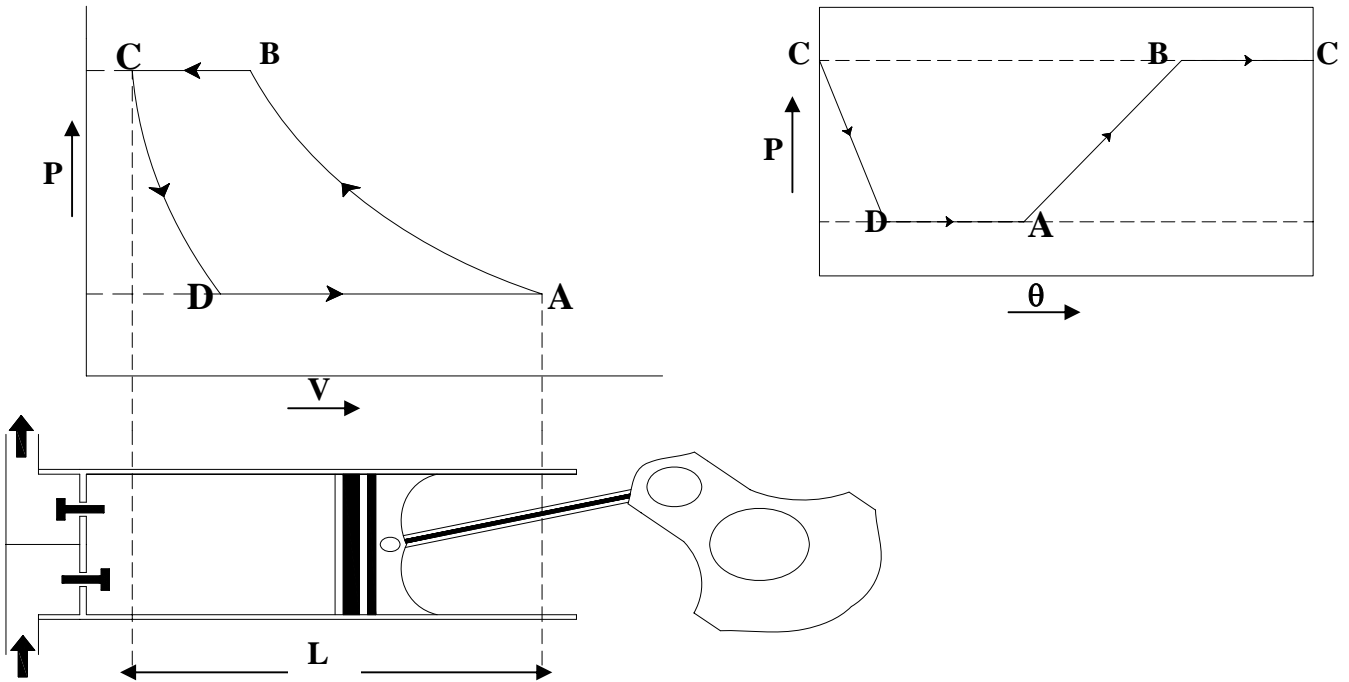
This space along with all other spaces between the closed valves and the piston at the inner dead center (IDC) is called as Clearance volume,  $V_c$ . The ratio of the clearance volume to the swept volume is called as Clearance ratio,  $\varepsilon$ , i.e.,

$$\varepsilon = \frac{V_c}{V_{sw}} \quad (18.13)$$

The clearance ratio  $\varepsilon$  depends on the arrangement of the valves in the cylinder and the mean piston velocity. Normally  $\varepsilon$  is less than 5 percent for well designed compressors with moderate piston velocities ( $\approx 3 \text{ m/s}$ ), however, it can be higher for higher piston speeds.

Due to the presence of the clearance volume, at the end of the discharge stroke, some amount of refrigerant at the discharge pressure  $P_c$  will be left in the clearance volume. As a result, suction does not begin as soon as the piston starts moving away from the IDC, since the pressure inside the cylinder is higher than the suction pressure ( $P_c > P_e$ ). As shown in Fig. 18.4, suction starts only when the pressure inside the cylinder falls to the suction pressure in an ideal compressor with clearance. This implies that even though the compressor swept volume,  $V_{sw} = V_A - V_C$ , the actual volume of the refrigerant that entered the cylinder during suction stroke is  $V_A - V_D$ . As a result, the volumetric efficiency of the compressor with clearance,  $\eta_{v,cl}$  is less than 100 percent, i.e.,

$$\eta_{v,cl} = \frac{\text{Actual volume of refrigerant compressed}}{\text{Swept volume of the compressor}} = \left( \frac{V_A - V_D}{V_A - V_C} \right) \quad (18.14)$$



**Fig.18.4.** Ideal reciprocating compressor with clearance

From Fig.18.4, the clearance volumetric efficiency can be written as:

$$\eta_{v,cl} = \left( \frac{V_A - V_D}{V_A - V_C} \right) = \frac{(V_A - V_C) + (V_C - V_D)}{(V_A - V_C)} = 1 + \left( \frac{(V_C - V_D)}{(V_A - V_C)} \right) \quad (18.15)$$

$$\text{Since the clearance ratio, } \varepsilon = \frac{V_C}{V_{sw}} = \frac{V_C}{V_A - V_C} \Rightarrow (V_A - V_C) = \frac{V_C}{\varepsilon} \quad (18.16)$$

Substituting the above equation in the expression for clearance volumetric efficiency; we can show that:

$$\eta_{v,cl} = 1 + \left( \frac{(V_C - V_D)}{(V_A - V_C)} \right) = 1 + \frac{\varepsilon(V_C - V_D)}{V_C} = 1 + \varepsilon - \varepsilon \left( \frac{V_D}{V_C} \right) \quad (18.17)$$



Since the mass of refrigerant in the cylinder at points C and D are same, we can express the ratio of cylinder volumes at points D and C in terms of ratio of specific volumes of refrigerant at D and C, i.e.,

$$\left(\frac{V_D}{V_C}\right) = \left(\frac{v_D}{v_C}\right) \quad (18.18)$$

Hence, the clearance volumetric efficiency is given by:

$$\eta_{V,cl} = 1 + \varepsilon - \varepsilon \left(\frac{V_D}{V_C}\right) = 1 + \varepsilon - \varepsilon \left(\frac{v_D}{v_C}\right) \quad (18.19)$$

If we assume the re-expansion process also to follow the equation  $Pv^k = \text{constant}$ , then:

$$\left(\frac{v_D}{v_C}\right) = \left(\frac{P_C}{P_D}\right)^{1/k} = \left(\frac{P_c}{P_e}\right)^{1/k} \quad (18.20)$$

Hence the clearance volumetric efficiency is given by:

$$\eta_{V,cl} = 1 + \varepsilon - \varepsilon \left(\frac{P_c}{P_e}\right)^{1/k} = 1 - \varepsilon [r_p^{1/k} - 1] \quad (18.21)$$

where  $r_p$  is the pressure ratio,  $P_c/P_e$ .

The above expression holds good for any reversible compression process with clearance. If the process is not reversible, adiabatic (i.e., non-isentropic) but a reversible polytropic process with an index of compression and expansion equal to  $n$ , then  $k$  in the above equation has to be replaced by  $n$ , i.e., in general for any reversible compression process;

$$\eta_{V,cl} = 1 + \varepsilon - \varepsilon \left(\frac{P_c}{P_e}\right)^{1/n} = 1 - \varepsilon [r_p^{1/n} - 1] \quad (18.22)$$

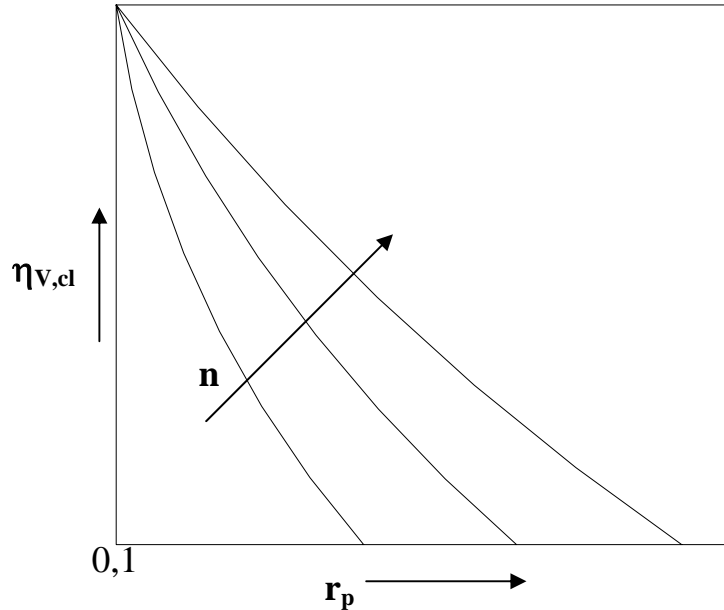
The above expression shows that  $\eta_{V,cl} \downarrow$  as  $r_p \uparrow$  and  $\varepsilon \uparrow$  as shown in Fig.18.5. It can also be seen that for a given compressor with fixed clearance ratio  $\varepsilon$ , there is a limiting pressure ratio at which the clearance volumetric efficiency becomes zero. This limiting pressure ratio is obtained from the equation:

$$\begin{aligned} \eta_{V,cl} &= 1 - \varepsilon [r_p^{1/n} - 1] = 0 \\ \Rightarrow r_{p,max} &= \left[ \frac{1 + \varepsilon}{\varepsilon} \right]^n \end{aligned} \quad (18.23)$$

The mass flow rate of refrigerant compressed with clearance  $\dot{m}_{cl}$  is given by:

$$\dot{m}_{cl} = \eta_{v,cl} \frac{\dot{V}_{sw}}{v_e} \quad (18.24)$$

Thus the mass flow rate and hence the refrigeration capacity of the system decreases as the volumetric efficiency reduces, in other words, the required size of the compressor increases as the volumetric efficiency decreases.



**Fig.18.5.** Effect of pressure ratio ( $r_p$ ) and index of compression ( $n$ ) on clearance volumetric efficiency ( $\eta_{v,cl}$ )

Work input to the compressor with clearance:

If we assume that both compression and expansion follow the same equation  $Pv^n = \text{constant}$  (i.e., the index of compression is equal to the index of expansion), then the extra work required to compress the vapour that is left in the clearance volume will be exactly equal to the work output obtained during the re-expansion process. Hence, the clearance for this special case does not impose any penalty on work input to the compressor. The total work input to the compressor during one cycle will then be equal to the area A-B-C-D-A on P-V diagram.

The specific work with and without clearance will be given by the same expression:

$$w_{id} = \int_{P_e}^{P_c} v \cdot dP = P_e v_e \left( \frac{n}{n-1} \right) \left[ \left( \frac{P_c}{P_e} \right)^{\frac{n-1}{n}} - 1 \right] \quad (18.25)$$

However, since the mass of refrigerant compressed during one cycle is different with and without clearance, the power input to the compressor will be different with and without clearance. The power input to the compressor and mean effective pressure (mep) with clearance are given by:

$$W_c = \dot{m} w_{id} = \left( \eta_{v,cl} \frac{\dot{V}_{sw}}{v_e} \right) w_{id} \quad (18.26)$$

$$\text{mep} = \eta_{v,cl} \frac{W_{id}}{V_e} \quad (18.27)$$

Thus the power input to the compressor and mep decrease with clearance due to decrease in mass flow rate with clearance.

If the process is reversible and adiabatic (i.e.,  $n = k$ ), then the power input to the compressor with clearance is given by:

$$W_c = \left( \eta_{v,cl} \frac{\dot{V}_{sw}}{V_e} \right) (h_B - h_A) = \left( \eta_{v,cl} \frac{\dot{V}_{sw}}{V_e} \right) \Delta h_{c,s} \quad (18.28)$$

where  $\Delta h_{c,s}$  is the isentropic work of compression (kJ/kg)

### Questions and answers:

1. Which of the following is not positive displacement type compressor?

- Rotary vane compressor
- Rotary screw type compressor
- Centrifugal compressor
- Acoustic compressor

**Ans.: c)**

2. Compared to a hermetic compressor, an open type compressor:

- Offers higher efficiency
- Offers lower noise
- Offers better compressor cooling
- Offers serviceability and flexibility

**Ans.: a), c) and d)**

3. Hermetic compressors are used mainly in smaller systems as they:

- Yield higher COP
- Do not require frequent servicing
- Offer the flexibility of using any refrigerant
- Can be used under different load conditions efficiently

**Ans.: b)**

4. In reciprocating compressors, clearance is provided:
- To improve the volumetric efficiency of the compressor
  - To accommodate valves
  - To account for thermal expansion due to temperature variation
  - To reduce power consumption of the compressor

**Ans.: b) and c)**

5. The clearance volumetric efficiency of a reciprocating compressor depends on:
- Properties of the refrigerant
  - Operating temperatures
  - Clearance volume
  - All of the above

**Ans.: d)**

6. A spacer is used in reciprocating compressors to introduce clearance volume. A refrigerant manufacturer wishes to standardize the components of a reciprocating compressor for refrigeration systems of capacities of 2 kW and 2.5 kW by varying only the spacer. Both the systems use the same refrigerant, which has an isentropic index of compression of 1.116 and operate over a pressure ratio of 5. The operating temperatures are also same for both the systems. If the required clearance factor for the 2.5 kW system is 0.03, what should be the clearance factor for the 2.0 kW system?

**Ans.: Given:**

Pressure ratio,  $r_p = 5$  and index of compression  $\gamma = 1.116$  for both the compressors. The clearance factor for the 2.5 kW compressor  $\epsilon_{2.5} = 0.03$

When all other parameters are same except the capacity, then:

$$(Q_{e,2.5}/Q_{e,2.0}) = 2.5/2.0 = 1.25 = (m_{r,2.5}/m_{r,2.0}) = (\eta_{v,2.5}/\eta_{v,2.0})$$

where  $Q_e$  is the refrigeration capacity,  $m_r$  is the refrigerant mass flow rate and  $\eta_v$  is the clearance volumetric efficiency of the compressor.

Substituting the expression for volumetric efficiency;

$$\frac{\eta_{v,2.5}}{\eta_{v,2.0}} = \frac{1 - \epsilon_{2.5}(r_p^{1/\gamma} - 1)}{1 - \epsilon_{2.0}(r_p^{1/\gamma} - 1)} = 1.25$$

substituting the values of pressure ratio, index of compression and the clearance factor of 2.5 kW compressor in the above expression, we obtain:

$$\epsilon_{2.0} = 0.086 \quad (\text{Ans.})$$

7. Water is used in a Standard Single Stage (SSS) vapour compression refrigeration system. The system operates at an evaporator temperature of 4.5°C (pressure = 0.8424 kPa) and a condenser temperature of 38°C (pressure = 6.624 kPa). Assume that the water vapour behaves as an ideal gas with  $c_p/c_v = 1.322$  and calculate the discharge temperature if compression is isentropic. Also calculate COP and volumic refrigeration effect if the refrigeration effect is 2355 kJ/kg. Molecular weight of water = 18 kg/kmol, Universal gas constant = 8.314 kJ/kmol.K

**Ans.:** Given:

Evaporator temperature,  $T_e = 4.5^\circ\text{C} = 277.5 \text{ K}$

Evaporator pressure,  $P_e = 0.8424 \text{ kPa}$

Condenser temperature,  $T_c = 38^\circ\text{C} = 311 \text{ K}$

Condenser pressure,  $P_c = 6.624 \text{ kPa}$

Isentropic index of compression,  $\gamma = c_p/c_v = 1.322$

Refrigeration effect,  $q_e = 2355 \text{ kJ/kg}$

Gas constant,  $R = 8.314/18 = 0.462 \text{ kJ/kg.K}$

Specific volume of refrigerant at compressor inlet,  $v_e = \left( \frac{RT_e}{P_e} \right) = 152.19 \text{ m}^3 / \text{kg}$

a) Discharge temperature,  $T_d$ :

$$T_d = T_e \left( \frac{P_c}{P_e} \right)^{\frac{\gamma-1}{\gamma}} = 458.6 \text{ K}$$

b) Work of compression,  $w_c$ :

$$w_c = RT_e \left( \frac{\gamma}{\gamma-1} \right) \left[ \left( \frac{P_c}{P_e} \right)^{\frac{\gamma-1}{\gamma}} - 1 \right] = 343.45 \text{ kJ/kg}$$

c) COP:

$$\text{COP} = \frac{q_e}{w_c} = 6.86$$

d) Volumic refrigeration effect,  $q_v$ :

$$q_v = \left( \frac{q_e}{v} \right) = 15.4 \text{ kJ/m}^3$$

8. An ammonia based refrigeration system with a refrigeration capacity of 100TR (1TR=3.5167 kW) operates at an evaporating temperature of  $-36^{\circ}\text{C}$  (saturation pressure = 0.8845 bar) and a condensing temperature of  $30^{\circ}\text{C}$  (saturation pressure = 11.67 bar). Assume the system to operate on a single stage saturated (SSS) cycle. The compression process may be assumed to be isentropic. Under these conditions, the following property data are available:

Enthalpy of saturated vapour at the exit of evaporator,  $h_1 = 1414 \text{ kJ/kg}$

Enthalpy of saturated liquid at the exit of condenser,  $h_4 = 341.8 \text{ kJ/kg}$

Isentropic index of compression,  $\gamma = 1.304$

The compressor is an 8-cylinder, reciprocating type with a clearance ratio of 0.05 and speed of 1750 RPM. The stroke-to-bore ratio is 0.8. In the absence of superheat data, the refrigerant vapour may be assumed to behave as a perfect gas. The molecular weight of ammonia is 17.03 kg/kmol. Find:

- a) Power input to the compressor
- b) COP and cycle (second law) efficiency
- c) Compressor discharge temperature, and
- d) Compressor dimensions (diameter and stroke length)

Ans.: Given:

Refrigeration capacity,  $Q_e = 100 \text{ TR} = 351.67 \text{ kW}$

Evaporator temperature,  $T_e = -36^{\circ}\text{C} = 237 \text{ K}$

Evaporator pressure,  $P_e = 0.8845 \text{ bar} = 88.45 \text{ kPa}$

Condenser temperature,  $T_c = 30^{\circ}\text{C} = 303 \text{ K}$

Condenser pressure,  $P_c = 11.67 \text{ bar} = 1167 \text{ kPa}$

Molecular weight,  $M = 17.04 \text{ kg/kmol}$

Gas constant,  $R = 8.314/17.04 = 0.4882 \text{ kJ/kg.K}$

Speed of compressor,  $N = 1750 \text{ RPM}$

Clearance factor,  $\epsilon = 0.05$

No. of cylinders,  $n = 8$

Stroke-to-bore (L/D) ratio,  $\theta = 0.8$

a) Power input to compressor,  $W_c$ :

$$W_c = m_r \cdot w_c$$

where the mass flow rate  $m_r$  is given by:

$$m_r = \left( \frac{Q_e}{h_1 - h_4} \right) = 0.328 \text{ kg/s}$$

work of compression,  $w_c$  is given by:

$$w_c = RT_e \left( \frac{\gamma}{\gamma-1} \right) \left[ \left( \frac{P_c}{P_e} \right)^{\frac{\gamma-1}{\gamma}} - 1 \right] = 409.6 \text{ kJ/kg}$$

Substituting these values, we find that the power input to the compressor is given by:

$$W_c = 134.35 \text{ kW}$$

b) COP and second law efficiency

$$\text{COP} = \frac{Q_e}{W_c} = 2.618$$

Second law efficiency,  $\eta_{II}$ :

$$\eta_{II} = \frac{\text{COP}}{\text{COP}_{\text{Carnot}}} = \text{COP} \left( \frac{T_c - T_e}{T_e} \right) = 0.729$$

c) Discharge temperature,  $T_d$ :

$$T_d = T_e \left( \frac{P_c}{P_e} \right)^{\frac{\gamma-1}{\gamma}} = 432.7 \text{ K}$$

d) Compressor dimensions, L and D

Swept volume,  $V_{sw}$  is given by:

$$V_{sw} = \frac{\pi}{4} D^2 L N n = \frac{\pi}{4} D^3 \theta N n = \frac{V_e}{\eta_v}$$

The volumetric efficiency  $\eta_v$  is given by:

$$\eta_v = 1 - \varepsilon \left[ \left( \frac{P_c}{P_e} \right)^{\frac{1}{\gamma}} - 1 \right] = 0.6885$$

The actual volumetric flow rate of refrigerant at compressor inlet,  $V_e$  is given by:

$$V_e = m_r \cdot v_e = m_r \cdot \frac{RT_e}{P_e} = 0.4293 \text{ m}^3 / \text{s}$$

Substituting these values in the expression for swept volume  $V_{sw}$ , we obtain:

$$V_{sw} = 0.6235 \text{ m}^3/\text{s}, \text{ and}$$

$$D = 0.162 \text{ m and } L = 0.8D = 0.1296 \text{ m (ans.)}$$



# Lesson

## 19

# Performance Of Reciprocating Compressors

## The specific objectives of this lecture are to:

1. Discuss the performance aspects of ideal reciprocating compressors with clearance, specifically:
  - a) Effect of evaporator temperature on system performance at a fixed condenser temperature (*Section 19.1.1*)
  - b) Effect of condenser temperature on system performance at a fixed evaporator temperature (*Section 19.1.1*)
  - c) Effects of pressure ratio and type of refrigerant on compressor discharge temperature (*Section 19.1.3*)
2. Discuss the performance aspects of actual compressor processes by considering:
  - a) Effect of heat transfer in the suction line and compressor (*Section 19.2.1*)
  - b) Effects of pressure drops in the suction and discharge lines and across suction and discharge valves of compressor (*Section 19.2.2*)
  - c) Effect of refrigerant leakage (*Section 19.2.3*)
3. Describe various methods of capacity control (*Section 19.3*)
4. Discuss methods of compressor lubrication (*Section 19.4*)

At the end of the lesson, the student should be able to:

1. Describe qualitatively the effects of evaporator and condenser temperatures on performance of reciprocating compressors
2. Discuss the effects of heat transfer, pressure drops and refrigerant leakage on performance of actual compressors
3. Explain various methods of regulating the capacity of reciprocating compressors, and
4. Discuss aspects of compressor lubrication

## 19.1. Ideal compressor with clearance:

### 19.1.1. Effect of evaporator temperature:

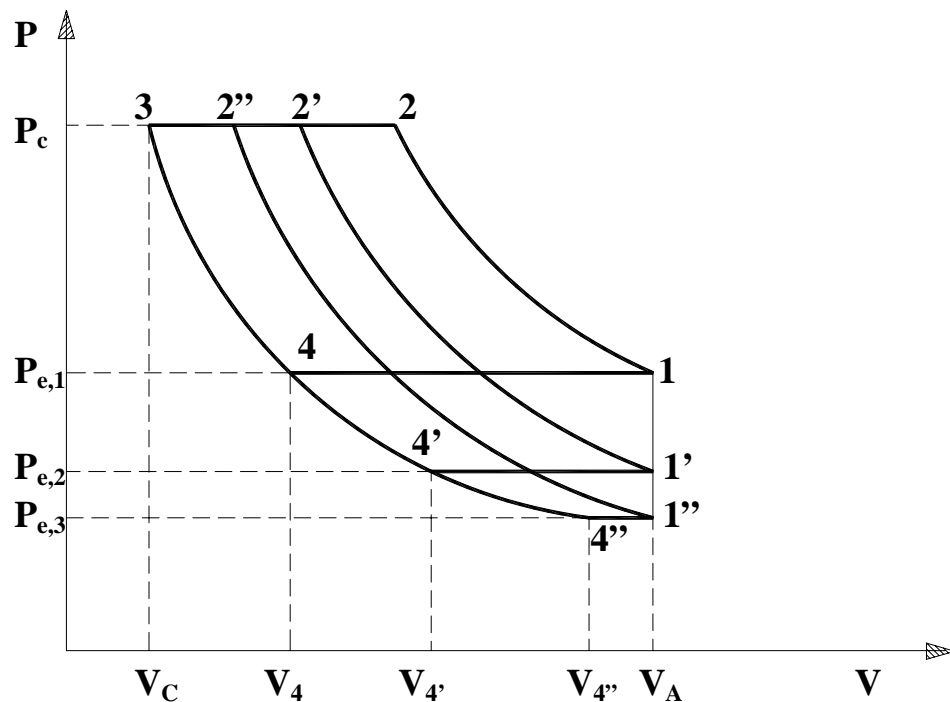
The effect of evaporator temperature on performance of the system is obtained by keeping the condenser temperature (pressure) and compressor displacement rate and clearance ratio fixed. To simplify the discussions, it is further assumed that the refrigeration cycle is an SSS cycle.

a) On Volumetric efficiency and refrigerant mass flow rate:

The volumetric of the compressor with clearance is given by:

$$\eta_{v,cl} = 1 + \varepsilon - \varepsilon \left( \frac{P_c}{P_e} \right)^{1/n} = 1 - \varepsilon \left[ r_p^{1/n} - 1 \right] \quad (19.1)$$

For a given condensing temperature (or pressure), the pressure ratio  $r_p$  increases as the evaporator temperature (or evaporator pressure) decreases. Hence, from the expression for clearance volumetric efficiency, it is obvious that the volumetric efficiency decreases as evaporator temperature decreases. This is also explained with the help of Fig.19.1, which shows the P-V diagram for different evaporator pressures. As shown, as the evaporator pressure decreases, the volume of refrigerant compressed decreases significantly, since the compressor displacement remains same the clearance volumetric efficiency decreases as evaporator temperature decreases. In fact, as explained in the earlier lecture, at a limiting pressure ratio, the volumetric efficiency becomes zero.

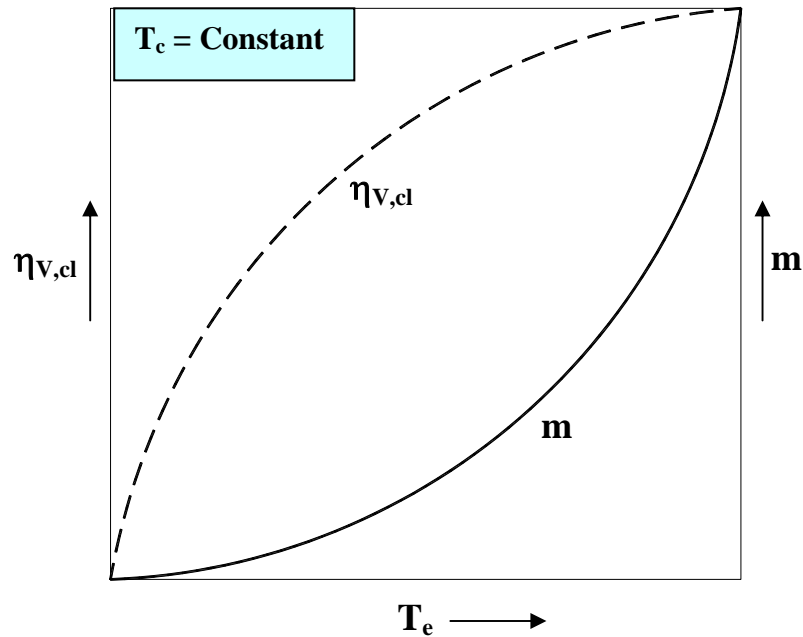


**Fig.19.1.** P-V diagram for different evaporator pressures and a fixed condenser pressure

The mass flow rate of refrigerant  $\dot{m}$  is given by:

$$\dot{m} = \eta_{V,cl} \frac{\dot{V}_{sw}}{v_e} \quad (19.2)$$

As the evaporator temperature decreases the clearance volumetric efficiency decreases and the specific volume of refrigerant at compressor inlet  $v_e$  increases. As a result of these two effects, the mass flow rate of refrigerant through the compressor decreases rapidly as the evaporator temperature decreases as shown in Fig.19.2.



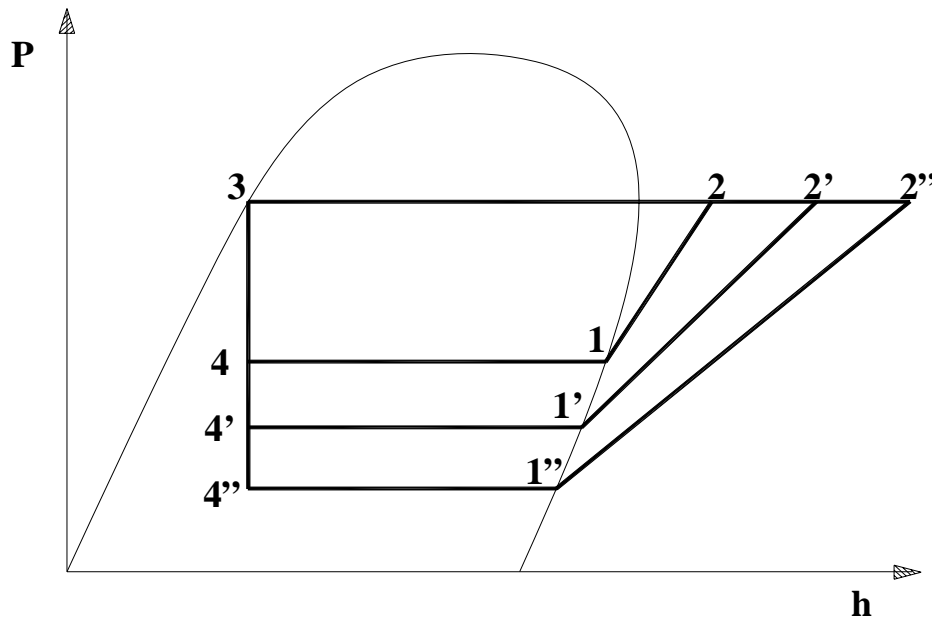
**Fig.19.2.** Effect of evaporator temperature on clearance volumetric efficiency and refrigerant mass flow rate

b) On refrigeration effect and refrigeration capacity:

A compressor alone cannot provide refrigeration capacity. By refrigeration capacity of compressor what we mean is the capacity of a refrigeration system that uses the compressor under discussion. Figure 19.3 (a) shows the SSS cycle on P-h diagram at different evaporator temperatures. It can be seen from the figure that the refrigeration effect,  $q_e$  ( $q_e = h_1 - h_4$ ) increases marginally as the evaporator temperature is increased. This is due to the shape of the saturation vapour curve on P-h diagram. The effect of  $T_e$  on refrigerant effect is also shown in Fig.19.3(b).

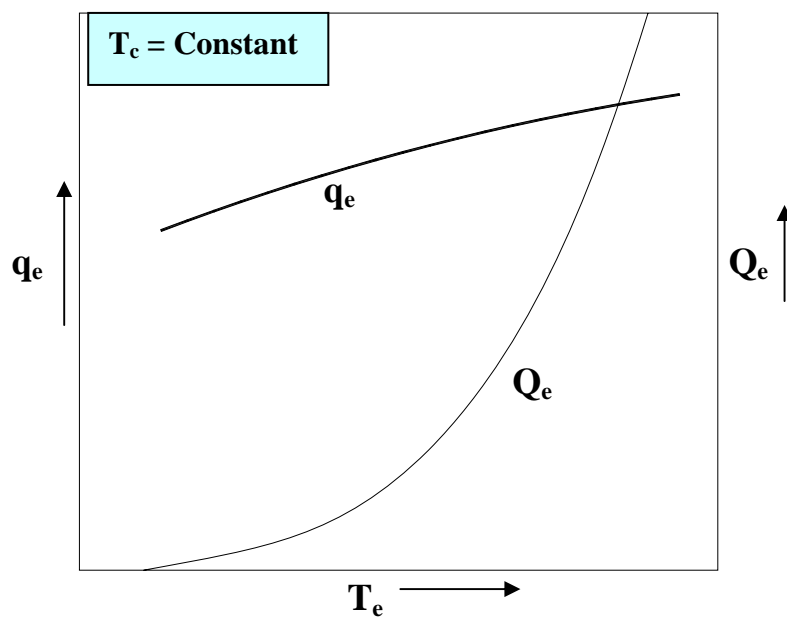
The refrigeration capacity of the compressor  $Q_e$  is given by:

$$Q_e = \dot{m} \cdot q_e \quad (19.3)$$



**Fig.19.3(a):** Effect of evaporator temperature on refrigeration effect on P-h diagram

Since mass flow rate of refrigerant increases rapidly and refrigerant effect also increases, though marginally with increase in evaporator temperature, the refrigeration capacity increases sharply with increase in evaporator temperature as shown in Fig.19.3(b).



**Fig.19.3(b):** Effect of evaporator temperature on refrigeration effect and refrigeration capacity

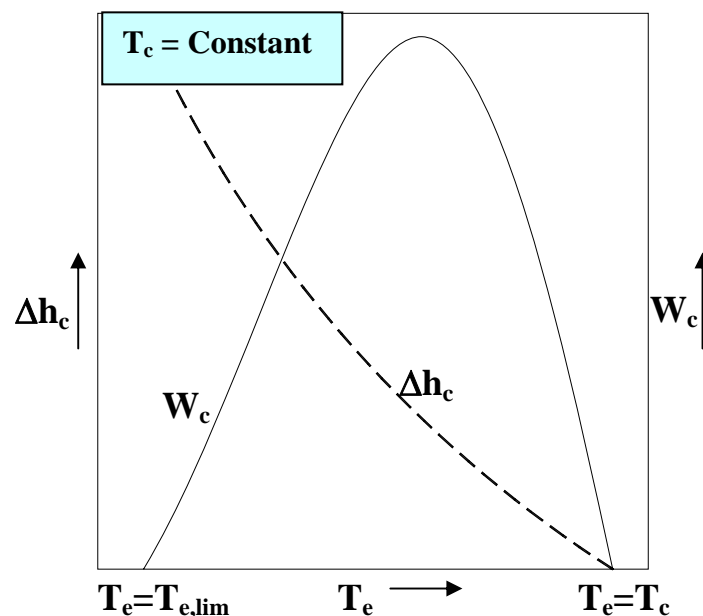
c) On work of compression and power requirement:

At a constant condenser temperature as evaporator temperature increases the work of compression,  $\Delta h_c (= h_2-h_1)$  decreases as shown in Fig.19.3(a). This is due to the divergent nature of isentropes in the superheated region. The work of compression becomes zero when the evaporator temperature becomes equal to the condenser temperature ( $T_e=T_c$ ) as shown in Fig. 19.4.

The power input to the compressor is given by:

$$W_c = \dot{m} \cdot \Delta h_c \quad (19.4)$$

As discussed before, for a given clearance ratio and condenser temperature, the volumetric efficiency and hence the mass flow rate becomes zero at a lower limiting value of evaporator temperature ( $T_e = T_{e,lim}$ ). Since the work of compression becomes zero when the evaporator temperature equals the condenser temperature, the power input to the compressor, which is a product of mass flow rate and work of compression is zero at a low evaporator temperature (at which the mass flow rate is zero). And the power input also becomes zero when evaporator temperature equals condenser temperature (at which the work of compression becomes zero). This implies that as evaporator temperature is increased from the limiting value, the power curve increases from zero, reaches a peak and then becomes zero as shown in Fig.19.4.



**Fig.19.4:** Effect of evaporator temperature on work of compression ( $\Delta h_c$ ) and power input to compressor ( $W_c$ )

The variation of compressor power input with evaporator temperature has a major practical significance. As mentioned before, there is an evaporator temperature at which the power reaches a maximum value. If the design evaporator temperature of the refrigeration system is less than the evaporator temperature at which the power is maximum, then the design power requirement is lower than the peak power input. However, during the initial [pull-down](#) period, the initial evaporator temperature may lie to the left of the power peak. Then as the system runs steadily the evaporator temperature reduces and the power requirement passes through the peak point. If the motor is designed to suit the design power input then the motor gets overloaded during every pull-down period as the peak power is greater than the design power input. Selecting an oversized motor to meet the power peak is not an energy efficient solution, as the motor will be underutilized during the normal operation. One way of overcoming the problem is to throttle the suction gas during the pull-down so that the refrigerant mass flow rate is reduced and the motor does not pass through the power peak. In multi-cylinder compressors, some of the cylinders can be unloaded during the pull-down so as to reduce the power requirement.

d) On COP and volume flow rate per unit capacity:

The COP of the system is defined as:

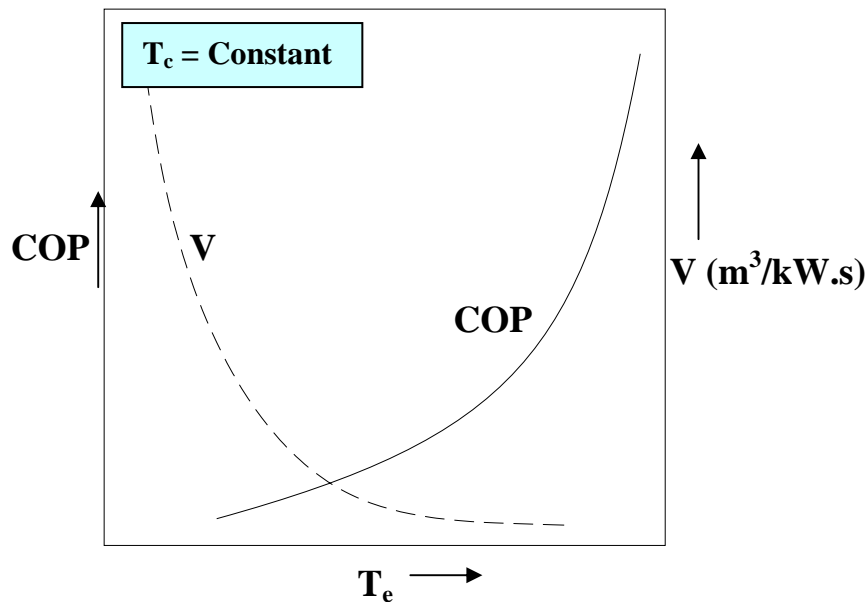
$$\text{COP} = \frac{Q_e}{W_c} = \frac{q_e}{\Delta h_c} \quad (19.5)$$

As discussed before, as the evaporator temperature increases the refrigeration effect,  $q_e$  increases marginally and the work of compression,  $\Delta h_c$  reduces sharply. As a result the COP of the system increases rapidly as the evaporator temperature increases as shown in Fig.19.5.

The volume flow rate per unit capacity,  $V$  is given by:

$$V = \frac{\eta_{V,cl} \cdot \dot{V}_{sw}}{Q_e} = \frac{v_e}{q_e} \quad (19.6)$$

As evaporator temperature increases the specific volume of the refrigerant at compressor inlet reduces rapidly and the refrigeration effect increases marginally. Due to the combined effect of these two, the volume flow rate of refrigerant per unit capacity reduces sharply with evaporator temperature as shown in Fig. 19.5. This implies that for a given refrigeration capacity, the required volumetric flow rate and hence the size of the compressor becomes very large at very low evaporator temperatures.



**Fig.19.5:** Effect of evaporator temperature on COP and volume flow rate per unit capacity ( $V$ )

#### 19.1.2. Effect of condenser temperature:

Atmospheric air is the cooling medium for most of the refrigeration systems. Since the ambient temperature at a location can vary over a wide range, the heat rejection temperature (i.e., the condensing temperature) may also vary widely. This affects the performance of the compressor and hence the refrigeration system. The effect of condensing temperature on compressor performance can be studied by keeping evaporator temperature constant.

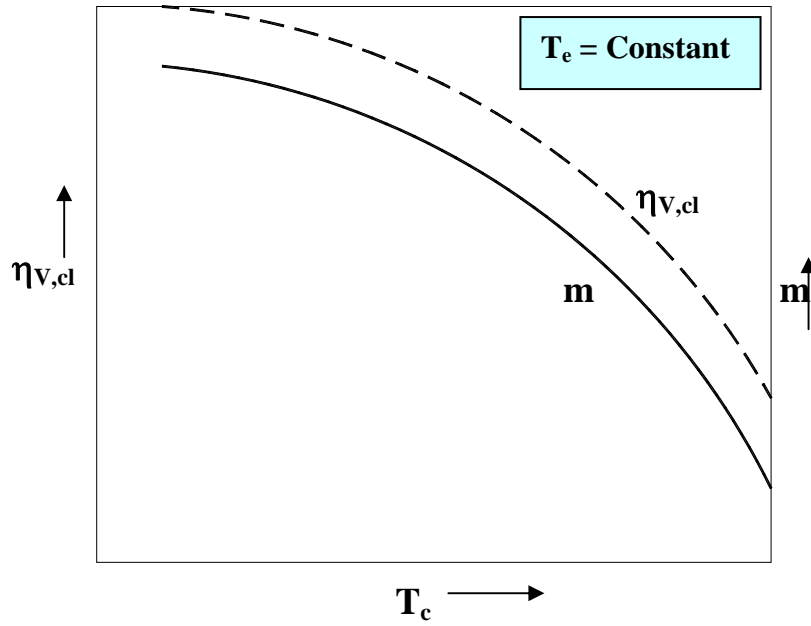
##### a) On volumetric efficiency and refrigerant mass flow rate:

Figure 19.6 shows the effect of condensing temperature on clearance volumetric efficiency and mass flow rate of refrigerant. At a constant evaporator temperature as the condensing temperature increases, the pressure ratio increases, hence, both the volumetric efficiency and mass flow rate decrease as shown in the figure. However, the effect of condensing temperature on mass flow rate is not as significant as the evaporator temperature as the specific volume of refrigerant at compressor inlet is independent of condensing temperature.

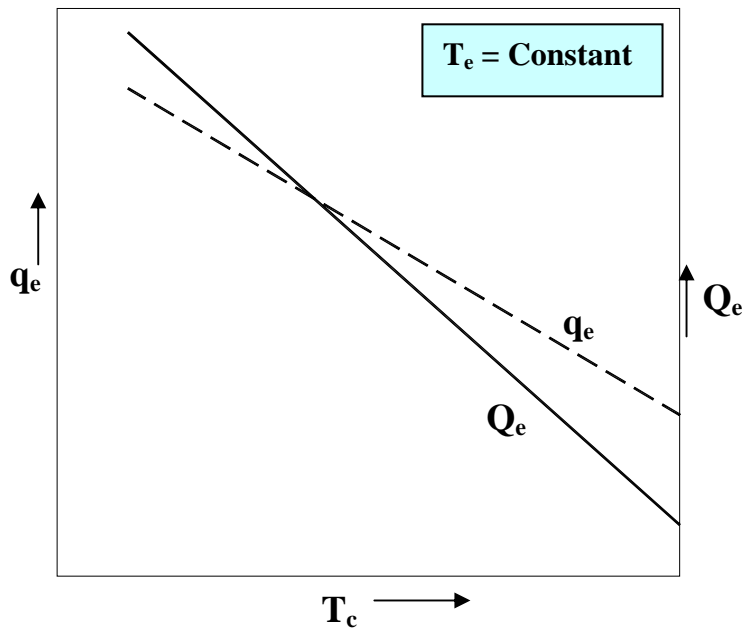
##### b) On refrigeration effect and refrigeration capacity:

At a constant evaporator temperature as the condensing temperature increases, then the enthalpy of refrigerant at the inlet to the evaporator increases. Since the evaporator enthalpy remains constant at a constant evaporator temperature, the refrigeration effect decreases with increase in condensing temperature as shown in Fig. 19.7. The refrigeration capacity ( $Q_e$ ) also reduces with increase in condensing temperature as both the mass flow rate and refrigeration effect decrease as shown in Fig.19.7.





**Fig.19.6.** Effect of condenser temperature on clearance volumetric efficiency and mass flow rate of refrigerant



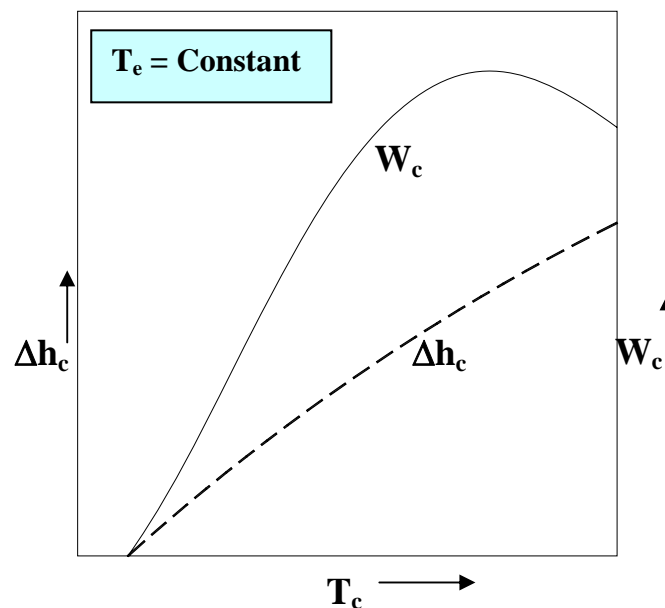
**Fig.19.7.** Effect of condenser temperature on refrigeration effect and refrigeration capacity

c) On work of compression and power requirement:

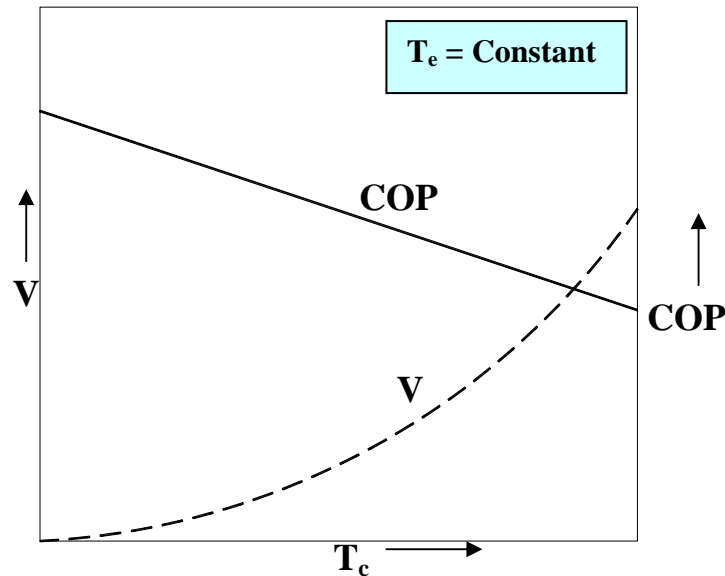
The work of compression is zero when the condenser temperature is equal to the evaporator temperature, on the other hand at a limiting condensing temperature the mass flow rate of refrigerant becomes zero as the clearance volumetric efficiency becomes zero as explained before. Hence, similar to the effect of evaporator temperature on power curve, the compressor power input increases from zero (work of compression is zero), reaches a peak and then again becomes zero at a high value of condensing temperature as shown in Fig.19.8. However, the peak power in this case is not as critical as with evaporator temperature since the chances of condenser operating at such a high temperatures are rare.

d) On COP and volume flow rate per unit capacity:

As condensing temperature increases the refrigeration effect reduces marginally and work of compression increases, as a result the COP reduces as shown in Fig.19.9. Even though the specific volume at compressor inlet is independent of condensing temperature, since the refrigeration effect decreases with increase in condensing temperature, the volume flow rate of refrigerant per unit capacity increases as condenser temperature increases as shown in Fig.19.9.



**Fig.19.8:** Effect of condenser temperature on work of compression and power input to compressor



**Fig.19.9:** Effect of condensing temperature on COP and volume flow rate per unit capacity ( $V$ )

The above discussion shows that the performance of the system degrades as the evaporator temperature decreases and condensing temperature increases, i.e., the temperature lift increases. This is in line with the effect of these temperatures on reverse Carnot refrigeration system. It is seen that compared to the condensing temperature, the effect of evaporator temperature is quite significant. When the heat sink temperature does not vary too much then the effect of condensing temperature may not be significant.

### 19.1.3. Compressor discharge temperature:

If the compressor discharge temperature is very high then it may result in breakdown of the lubricating oil, causing excessive wear and reduced life of the compressor valves (mainly the discharge valve). In hermetic compressors, the high discharge temperature adversely affects the motor insulation (unless the insulation is designed for high temperatures). When the temperature is high, undesirable chemical reactions may take place inside the compressor, especially in the presence of water. This may ultimately damage the compressor.

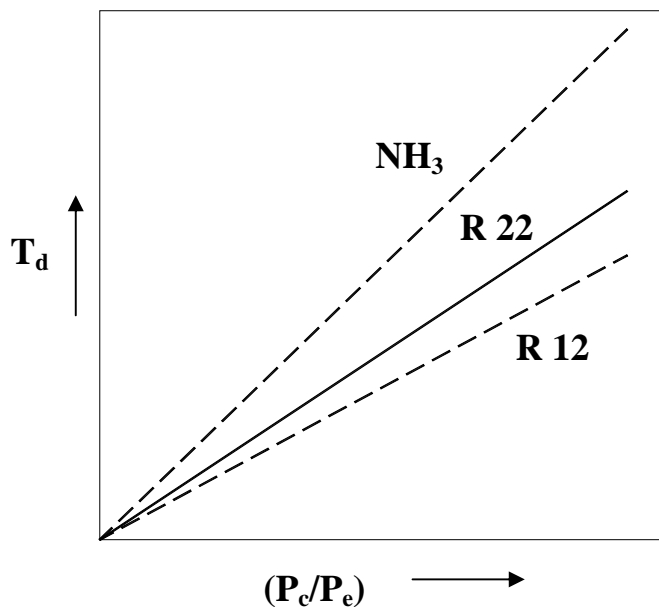
If the compression process is assumed to be isentropic and the refrigerant vapour is assumed to be have as a perfect gas, then the following equations apply:

$$Pv^\gamma = \text{constant} \text{ and } Pv = RT \quad (19.7)$$

Then the discharge temperature,  $T_d$  is given by:

$$T_d = T_e \left( \frac{P_c}{P_e} \right)^{\frac{\gamma-1}{\gamma}} \quad (19.8)$$

Thus for a given compressor inlet temperature,  $T_e$ , the discharge temperature  $T_d$  increases as the pressure ratio ( $P_c/P_e$ ) and specific heat ratio  $\gamma$  increase. Even though refrigerant vapour may not exactly behave as a perfect gas, the trends remain same. Figure 19.10 shows the variation of discharge temperature as a function of pressure ratio for three commonly used refrigerants, ammonia, R 22 and R 12. As shown in the figure since specific heat ratio of ammonia is greater than R 22, which in turn is greater than R 12, at a given pressure ratio, the discharge temperature of ammonia is higher than R 22, which in turn is higher than R 12. Since the high discharge temperature of ammonia may damage the lubricating oil, normally ammonia compressors are cooled externally using water jackets.



**Fig.19.10:** Variation of compressor discharge temperature with pressure ratio for different refrigerants

## 19.2. Actual compression process

Actual compression processes deviate from ideal compression processes due to:

- i. Heat transfer between the refrigerant and surroundings during compression and expansion, which makes these processes non-adiabatic
- ii. Frictional pressure drops in connecting lines and across suction and discharge valves
- iii. Losses due to leakage

### 19.2.1. Effect of heat transfer:

Heat transfer from the cylinder walls and piston to the refrigerant vapour takes place during the suction stroke and heat transfer from the refrigerant to the surroundings takes place at the end of the compression. In hermetic compressors additional heat transfer from the motor winding to refrigerant takes place. The effect of this heat transfer is to increase the temperature of refrigerant, thereby increasing the specific volume. This in general results in reduced volumetric efficiency and hence reduced refrigerant mass flow rate and refrigeration capacity. The extent of reduction in mass flow rate and refrigeration capacity depends on the pressure ratio, compressor speed and compressor design. As seen before, the discharge temperature and hence the temperature of the cylinder and piston walls increase with pressure ratio. As the compressor speed increases the heat transfer rate from the compressor to the surroundings reduces, which may result in higher refrigerant temperature. Finally, the type of external cooling provided and compressor design also affects the performance as it influences the temperature of the compressor.

Since the compression and expansion processes are accompanied by heat transfer, these processes are not adiabatic in actual compressors. Hence, the index of compression is not isentropic index but a polytropic index. However, depending upon the type of the compressor and the amount of external cooling provided, the compression process may approach an adiabatic process (as in centrifugal compressors) or a reversible polytropic process (as in reciprocating compressors with external cooling). The index of compression may be greater than isentropic index (in case of irreversible adiabatic compression). When the process is not reversible, adiabatic, then the polytropic index of compression 'n' depends on the process and is not a property of the refrigerant. Also the polytropic index of compression may not be equal to the polytropic index of expansion. Since the compression process in general is irreversible, the actual power input to the compressor will be greater than the ideal compression work. Sometimes the isentropic efficiency is used to estimate the actual work of compression. The isentropic efficiency  $\eta_{is}$  for the compressor is defined as:

$$\eta_{is} = \frac{\Delta h_{c,is}}{\Delta h_{c,act}} \quad (19.9)$$

where  $\Delta h_{c,is}$  is the isentropic work of compression and  $\Delta h_{c,act}$  is the actual work of compression. It is observed that for a given compressor the isentropic efficiency of the compressor is mainly a function of the pressure ratio. Normally the function varies from compressor to compressor, and is obtained by conducting experimental studies on compressors. The actual work of compression and actual power input can be obtained if the isentropic efficiency of the compressor is known as the isentropic work of compression can be calculated from the operating temperatures.

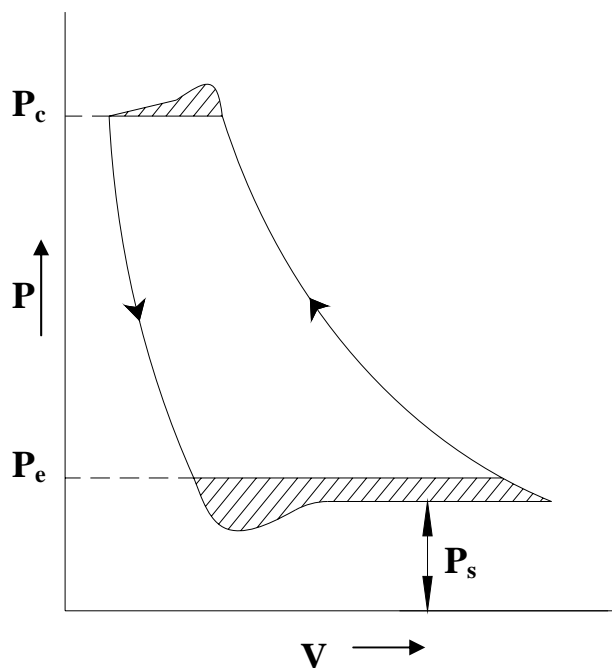
### 19.2.2. Effect of pressure drops:

In actual reciprocating compressors, pressure drop takes place due to resistance to fluid flow. Pressure drop across the suction valve is called as

“wire drawing”. This pressure drop can have adverse effect on compressor performance as the suction pressure at the inlet to the compressor  $P_s$  will be lower than the evaporator pressure as shown in Fig.19.11. As a result, the pressure ratio and discharge temperature increases and density of refrigerant decreases. This in turn reduces the volumetric efficiency, refrigerant mass flow rate and increases work of compression. This pressure drop depends on the speed of the compressor and design of the suction valve. The pressure drop increases as piston speed increases.

Even though the pressure drop across the discharge valve is not as critical as the pressure drop across suction valve, it still affects the compressor performance in a negative manner.

The net effect of pressure drops across the valves is to reduce the refrigeration capacity of the system and increase power input. The pressure drops also affect the discharge temperature and compressor cooling in an adverse manner.



**Fig.19.11:** Effects of suction and discharge side pressure drops on P-V diagram of a reciprocating compressor

### 19.2.3. Effect of leakage:

In actual compressors, refrigerant leakage losses take place between the cylinder walls and piston, across the suction and discharge valves and across the oil seal in open type of compressors. The magnitude of these losses depends upon the design of the compressor valves, pressure ratio, compressor speed and the life and condition of the compressor. Leakage losses increase as the pressure ratio increases, compressor speed decreases and the life of compressor increases. Due to the leakage, some amount of

refrigerant flows out of the suction valves at the beginning of compression stroke and some amount of refrigerant enters the cylinder through the discharge valves at the beginning of suction stroke. The net effect is to reduce the mass flow rate of refrigerant. Even though it is possible to minimize refrigerant leakage across cylinder walls, eliminating leakages across valves is not possible as it is not possible to close the valves completely during the running of the compressor.

As a result of the above deviations, the actual volumetric efficiency of refrigerant compressors will be lower than the clearance volumetric efficiency. It is difficult to estimate the actual efficiency from theory alone. Normally empirical equations are developed to estimate this parameter. The actual volumetric efficiency can be defined either in terms of volumetric flow rates or in terms of mass flow rates, i.e.,

$$\eta_{V,act} = \frac{\text{actual volumetric flow rate}}{\text{Compressor displacement rate}} = \frac{\text{actual mass flow rate}}{\text{maximum possible mass flow rate}}$$

In general,

$$\eta_{V,act} = \eta_{V,th} \frac{T_s}{T_{sc}} - \xi_L \quad (19.10)$$

where  $\eta_{V,th}$  = Theoretical volumetric efficiency obtained from P-V diagram  
 $T_s$  = Temperature of vapour at suction flange, K  
 $T_{sc}$  = Temperature of vapour at the beginning of compression, K  
 $\xi_L$  = Leakage loss (fraction or percentage)

Several tests on compressors show that the actual volumetric of a given compressor is mainly a function of pressure ratio, and for a given pressure ratio it remains practically constant, irrespective of other operating conditions. Also, compressors with same design characteristics will have approximately the same volumetric efficiency, irrespective of the size. It is shown that for a given compressor, the actual volumetric efficiency can be obtained from the empirical equation:

$$\eta_{V,act} = A - B(r_p)^C \quad (19.11)$$

where A, B and C are empirical constants to be obtained from actual test data and  $r_p$  is the pressure ratio.

Depending upon the compressor and operating conditions, the difference between actual and theoretical volumetric efficiency could be anywhere between 4 to 20 percent.

Since heat transfer rate and leakage losses reduce and pressure drops increase with increase in refrigerant velocity, the actual volumetric efficiency reaches a maximum at a certain optimum speed. An approximate relation for optimum speed as suggested by Prof. Gustav Lorentzen is:

$$V_{\text{opt}} / \sqrt{M} \approx 420 \text{ m/s} \quad (19.12)$$

where  $V_{\text{opt}}$  is the optimum velocity of the refrigerant through the valve port in m/s and  $M$  is the molecular weight of the refrigerant in kg/kmol. This relation suggests that higher the molecular weight of the refrigerant lower is the optimum refrigerant velocity.

### 19.3. Capacity control of reciprocating compressors:

Normally refrigerant compressors are designed to take care of the most severe operating conditions, which normally occurs when the cooling load is high and/or the condenser operates at high temperatures due to high heat sink temperatures. However, when the operating conditions are not so severe, i.e., when the cooling load is low and/or the heat sink temperature is low, then the compressor designed for peak load conditions becomes oversized. If no control action is taken, then the compressor adjusts itself by operating at lower evaporator temperature, which may affect the refrigerated space temperature. The temperature of the evaporator during part load conditions reduces as the rate at which the compressor removes refrigerant vapour from the evaporator exceeds the rate of vaporization in the evaporator. As a result the evaporator pressure, and hence the evaporator temperature reduces. Operating at low evaporator temperature may lead to other problems such as low air humidity, frosting of evaporator coils and freezing of the external fluid. To avoid these problems, the capacity of the compressor has to be regulated depending upon the load. Various methods available in practice for controlling the capacity of compressors are:

- a) Cycling or on-off control
- b) Back pressure regulation by throttling of suction gas
- c) Hot gas by-pass
- d) Unloading of cylinders in multi-cylinder compressors, and
- e) Compressor speed control

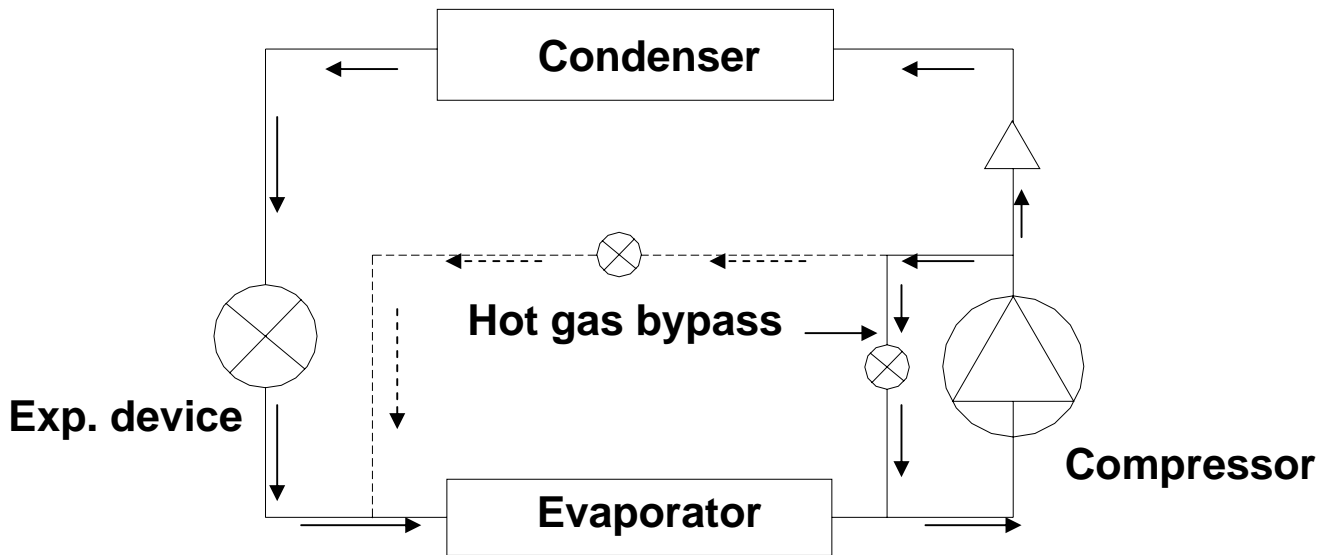
The cycling or on-off control is normally used in very small capacity refrigeration systems such as domestic refrigerators, room air conditioners, water coolers etc. The on-off control is achieved with the help of a thermostat, which normally senses the temperature inside the refrigerated space or evaporator temperature. As long as the temperature is greater than a set temperature (cut-out point) the compressor runs, and when the temperature falls below the cut-out temperature the thermostat switches-off the compressor. The temperature at which the compressor is switched-on again is known as cut-in temperature. The difference between the cut-in and cut-out temperatures is called as differential of the thermostat, which can be adjusted internally. The level of temperature at which the thermostat operates is called as the range of the thermostat, which can also be adjusted by the customer by turning a knob. For example, a thermostat may have a cut-in temperature of  $10^{\circ}\text{C}$  and a cut-out temperature of  $9^{\circ}\text{C}$ , in which case the differential is  $1^{\circ}\text{C}$ . By turning the thermostat knob, the same thermostat can be made to operate,



say at 7°C of cut-in temperature and 6°C of cut-out temperature. In this example, the differential has been kept fixed at 1°C, while the range has been varied. As mentioned, it is also possible to vary the differential so that the thermostat can operate at a cut-in temperature of 10°C and a cut-out temperature of 8°C, with a differential of 2°C. Thus the temperature in the refrigerated space varies between the cut-out and cut-in values. In stead of a thermostat which takes control action based on temperatures, it is also possible to use a pressure sensing device to initiate on-off control. This type of device is called a pressostat, and is designed to take control action by sensing the evaporator pressure. The on-off control is satisfactory in applications where the fluctuation in product temperatures due to on-off control is acceptable. Thus it is suitable when the thermal capacity of the product or the refrigerated space is large so that small variation in it can give sufficient variation in evaporator temperature. On-off control is not good when the temperature has to be regulated within a small range, in which case the compressor has to start and stop very frequently. Small compressor motors can be cycled for about 10 cycles per hour, whereas large compressor motors are normally not allowed to start and stop for more than one or two times in an hour.

Back-pressure regulation by throttling the suction gas reduces the refrigeration capacity of the compressor. However, this method is not normally used for regular capacity control as it does not reduce the compressor power input proportionately, consequently it is energy inefficient. This method is normally used during the pull-down period so as to avoid the power peak.

Hot gas bypass to suction side is an effective method of controlling the capacity. In this method, when the evaporator pressure falls below a predetermined value, a hot gas bypass valve is opened and hot refrigerant from the discharge side flows back into the suction side of the compressor. A constant pressure expansion valve can be used as a hot gas bypass valve. Though by this method the capacity of the compressor can be regulated quite closely, this method suffers from some disadvantages such as little or no reduction in compressor power consumption at reduced refrigeration capacities, excessive superheating of the suction gas resulting in overheating of the compressors. Hence, this method is normally used in small compressors. However, in conjunction with other efficient methods, hot gas bypass is used when it is required to regulate the capacity down to 0 percent or for unloaded starting. Overheating of the compressor can be reduced by sending the hot bypass gas to the evaporator inlet. This also maintains sufficiently high refrigerant velocity in the evaporator so that oil return to the compressor can be improved during low cooling loads. Figure 19.12 shows the schematic of a refrigeration system with a hot gas bypass arrangement. In the figure, the solid line is for the system in which the by-passed hot gas enters the inlet of the compressor, while the dashed line is for the system in which the by-passed hot gas enters at the inlet to the evaporator.



**Fig.19.12:** A vapour compression refrigeration system with hot gas bypass arrangement

Unloading of cylinders in multi-cylinder compressors is another effective method of regulating compressor capacity. This is achieved usually by keeping the suction valves of some of the cylinders open during the compression stroke. As a result, the suction vapour drawn into these cylinders during suction stroke is returned to the suction line during the compression stroke. This is done with the help of pressure sensing switch, which senses the low pressure in the evaporator and opens some of the suction valves. In addition to capacity regulation, this method is also used during pull-down so that the peak power point can be skipped. This method is efficient as the required power input reduces with reduced cooling load, though not in the same proportion. Hence, this is one of the methods commonly employed in large systems.

Controlling the capacity of the compressor by regulating its speed is one of the most efficient methods as the required power input reduces almost in the same proportion with cooling load. However, for complete control a variable frequency drive may be required, which increases the cost of the system. In addition, reducing the speed too much may effect the compressor cooling and oil return.

#### 19.4. Compressor lubrication:

Reciprocating compressors require lubrication to reduce wear between several parts, which rub against each other during the operation. Normally lubricating oil is used to lubricate the compressors. The lubricating oil usually comes in contact with the refrigerant and mixes with it, hence, it is essential to select a suitable oil in refrigerant compressors. The important properties that must be considered while selecting lubricating oil in refrigerant compressors are:

- a) Chemical stability
- b) Pour and/or floc points
- c) Dielectric strength, and
- d) Viscosity

In addition to the above, the nature of the refrigerant used, type and design of the compressor, evaporator and compressor discharge temperatures have to be considered while selecting suitable lubricating oils.

The oil should not undergo any chemical changes for many years of operation. This aspect is especially critical in hermetic compressor where, oil is not supposed to be changed for ten years or more. Since the discharge temperature is normally high in these compressors, the oil should not decompose even under very high temperatures. The chemical stability of the oil is inversely proportional to the number of unsaturated hydrocarbons present in the oil. For refrigerant compressors, oils with low percentage of unsaturated hydrocarbons are desirable.

The pour point of the oil may be defined as the lowest temperature at which the oil can flow or pour, when tested under specific conditions. The pour point is important for systems working at low evaporator temperatures. The pour point depends upon the wax content, higher the wax content, higher will be the pour point. Hence, for low temperature applications oils with low wax content should be used, otherwise the oil may solidify inside the evaporator tubes affecting the system performance and life of the compressor. The temperature at which the wax in the oil begins to precipitate is called as the cloud point. The floc point of the oil is the temperature at which wax will start to precipitate from a mixture of 90% R 12 and 10% oil by volume. In case of refrigerants such as R 12, viscosity of oil is reduced, as the refrigerant is soluble in oil. The floc point of the oil is a measure of the tendency of the oil to separate wax when mixed with an oil-soluble refrigerant. Hence it is an important parameter to be considered while selecting lubricating oils for these refrigerants. Since the tendency for wax to separate increases with amount of oil in refrigerant, the concentration of oil in refrigerant should normally be kept below 10 percent with these refrigerants. Floc point is not important in case of refrigerants that are not soluble in oil (e.g. ammonia).

Dielectric strength of the oil is a measure of its resistance to the flow of electric current. It is normally expressed in terms of the voltage required to cause an electric arc across a gap of 0.1 inch between two poles immersed in oil. Since impurities such as moisture, dissolved solids (metallic) reduce the dielectric strength of oil, a high dielectric strength is an indication of the purity of the oil. This parameter is very important in case of hermetic compressors as an oil with low dielectric strength may lead to shorting of the motor windings.

The viscosity of the oil is an important parameter in any lubricating system. The viscosity of the oil should be maintained within certain range for the lubrication system to operate effectively. If the viscosity is too low then the

wear between the rubbing surfaces will be excessive, in addition to this it may not act as a good sealing agent to prevent refrigerant leakage. However, if the viscosity is too high then fluid friction will be very high and the oil may not fill the small gaps between the rubbing surfaces, again leading to excessive wear. The problem is complicated in refrigerant compressors as the viscosity of the oil varies considerably with temperature and refrigerant concentration. The oil viscosity increases as temperature and concentration of refrigerant decrease and vice versa.

Both mineral oils as well as synthetic oils have been used as lubricating oils in refrigeration. The mineral oils have to be refined to improve their chemical stability and reduce their pour and/or floc points. Synthetic oils have been developed to provide high chemical stability, good lubricity, good refrigerant solubility, lower pour/floc points and required viscosity.

#### 19.4.1. Methods of lubrication:

Lubrication can be either splash type or force feed type. Normally small compressors (upto 10 kW input) are splash lubricated. Larger compressors use forced feed type lubrication. In splash type lubrication, the compressor crankcase which acts as an oil sump is filled with oil to a certain level. As the crankshaft rotates, the connecting rod and crankshaft dip into the oil sump causing the oil to be splashed on the rubbing surfaces. In some compressors, small scoops or dippers are attached to the connecting rod, which pick the oil and throws it onto the rubbing surfaces. In small, high-speed compressors, flooded type splash lubrication is used. In these modified type, slinger rings or screws are used for lifting the oil above crankshaft or main bearings, from where the oil floods over the rubbing surfaces. This prevents excessive oil carryover due to violent splashing in high-speed compressors.

In the forced feed method of lubrication an oil pump is used to circulate the oil to various rubbing surfaces under pressure. The oil drains back into the oil sump due to gravity and is circulated again.

If the refrigerants are not soluble in lubricating oil, then there is possibility of oil being carried away from the compressor and deposited elsewhere in the system. To prevent this, oil separators are used on the discharge side of the compressor, from where the oil is separated from the refrigerant vapour and is sent back to the compressor.

### Questions and answers:

1. The refrigeration capacity of a reciprocating compressor increases:

- a) As the evaporator temperature increases and condenser temperature decreases
- b) As the evaporator temperature decreases and condenser temperature increases
- c) As the evaporator and condenser temperatures increase
- d) As the evaporator and condenser temperatures decrease

**Ans. a)**

2. For a given refrigeration capacity, the required size of the compressor increases as:

- a) As the evaporator temperature increases and condenser temperature decreases
- b) As the evaporator temperature decreases and condenser temperature increases
- c) As the evaporator and condenser temperatures increase
- d) As the evaporator and condenser temperatures decrease

**Ans. b)**

3. During every pull-down, the reciprocating compressor is likely to be overloaded as:

- a) The initial refrigerant mass flow rate is high and work of compression is low
- b) The initial refrigerant mass flow rate is low and work of compression is high
- c) Both the mass flow rate and work of compression are high in the initial period
- d) None of the above

**Ans. a)**

4. Ammonia compressors normally have water jackets for cooling as:

- a) The latent heat of ammonia is high compared to synthetic refrigerants
- b) The boiling point of ammonia is high
- c) The critical temperature of ammonia is high
- d) The index of compression of ammonia is high

**Ans. d)**

5. The actual volumetric efficiency of a reciprocating compressor is smaller than the clearance volumetric efficiency due to:

- a) Pressure drop across suction line and suction valve
- b) Pressure drop across discharge line and discharge valve
- c) Heat transfer in suction line
- d) Leakage of refrigerant across valves
- e) All of the above

**Ans. e)**

6. When the compression process is reversible, polytropic with heat transfer from compressor, then:

- a) The index of compression will be smaller than the isentropic index of compression
- b) The index of compression will be higher than the isentropic index of compression
- c) Power input will be smaller than that of a reversible, isentropic process
- d) Discharge temperature will be higher than isentropic discharge temperature

**Ans. a) and c)**

7. As the speed of the compressor increases:

- a) Heat transfer rate from compressor increases
- b) Heat transfer rate from compressor decreases
- c) Pressure drops increase and leakage losses decrease
- d) Pressure drops decrease and leakage losses increase

**Ans. b) and c)**

8. On-off control is generally used only in small refrigeration capacity systems as:

- a) Variation in refrigerated space temperature may be acceptable in smaller systems
- b) Frequent start-and-stops can be avoided in small systems
- c) It is simple and inexpensive
- d) All of the above

**Ans. a) and c)**

9. Hot gas bypass to compressor inlet:

- a) Provides an effective means of capacity control
- b) Is an energy efficient method
- c) Leads to increased discharge temperature
- d) Provides effective cooling in hermetic compressor

**Ans. a) and c)**

3. A reciprocating compressor is to be designed for a domestic refrigerator of 100 W cooling capacity. The refrigerator operates at an evaporator temperature of  $-23.3^{\circ}\text{C}$  and a condensing temperature of  $54.4^{\circ}\text{C}$ . The refrigeration effect at these conditions is 87.4 kJ/kg. At the suction flange the temperature of the refrigerant is  $32^{\circ}\text{C}$  and specific volume is  $0.15463\text{ m}^3/\text{kg}$ . Due to heat transfer within the compressor the temperature of the refrigerant increases by  $15^{\circ}\text{C}$ . The indicated volumetric efficiency of the compressor is 0.85 and the leakage loss factor is 0.04. The rotational speed of the compressor is 2900 RPM. Find a) The diameter and stroke of the compressor in cms; b) Find the COP of the system if the actual mean effective pressure of the compressor is 5.224 bar.

Given:	Cooling capacity, $Q_e$	= 100 W = 0.1 kW
	Evaporator Temperature, $T_e$	= $-23.3^{\circ}\text{C}$
	Refrigeration effect, $q_e$	= 87.4 kJ/kg
	Temperature at suction flange, $T_s$	= $32^{\circ}\text{C}$
	Sp. vol. of vapour at flange, $v_s$	= $0.15463\text{ m}^3/\text{kg}$
	Temperature rise in compressor	= $15^{\circ}\text{C}$
	Indicated volumetric efficiency, $\eta_{v,th}$	= 0.85
	Leakage losses, $\xi_L$	= 0.04
	Mean effective pressure, $mep$	= 5.224 bar
	Rotational speed of compressor, $N$	= 2900 rpm

Find: a) Diameter and stroke length of compressor  
b) COP

**Ans:**

a) The mass flow rate of refrigerant,  $m$

$$m = \text{refrigeration capacity/refrigeration effect} \\ = (0.1/87.4) = \mathbf{1.1442 \times 10^{-3} \text{ kg/s}}$$

Volumetric flow rate at suction flange,  $V_r$

$$V_r = m \times v_s = \mathbf{1.7693 \times 10^{-4} \text{ m}^3/\text{s}}$$

Required compressor displacement rate,  $V_{sw} = V_r/\eta_{v,act}$

Actual volumetric efficiency,  $\eta_{v,act}$ :

$$\eta_{v,act} = \eta_{v,th} \frac{T_s}{T_{sc}} - \xi_L = 0.85 \frac{(273.15 + 32)}{(273.15 + 32 + 15)} - 0.04 = 0.77$$

Required compressor displacement rate,  $V_{sw} = V_r/\eta_{v,act} = 1.7693 \times 10^{-4}/0.77$   
 $= 2.298 \times 10^{-4} \text{ m}^3/\text{s}$

The compressor displacement rate is equal to:

$$\dot{V}_{sw} = n \left( \frac{\pi D^2 L}{4} \right) \left( \frac{N}{60} \right) = n \left( \frac{\pi D^3 \theta}{4} \right) \left( \frac{N}{60} \right)$$

where  $n$  is the number of cylinders and  $\theta$  is the stroke-to-bore ratio ( $L/D$ )

Since the refrigeration capacity is small, we can assume a single cylinder compressor, i.e.,  $n = 1$

Assuming a stroke-to-bore ratio  $\theta$  of **0.8** and substituting the input values in the above expression, we obtain:

Diameter of cylinder,  $D = 0.01963 \text{ m} = \mathbf{1.963 \text{ cm}}$ , and  
Stroke length,  $L = 0.8D = \mathbf{1.5704 \text{ cm}}$

b) COP:

Actual power input to the compressor,  $W_c$

$W_c = m_{ep} \times \text{displacement rate} = 5.224 \times 100 \times 2.298 \times 10^{-4} = \mathbf{0.12 \text{ kW}}$

**Hence, COP = (0.1/0.12) = 0.833**



# Lesson

## 20

# Rotary, Positive Displacement Type Compressors

## The specific objectives of this lecture are to:

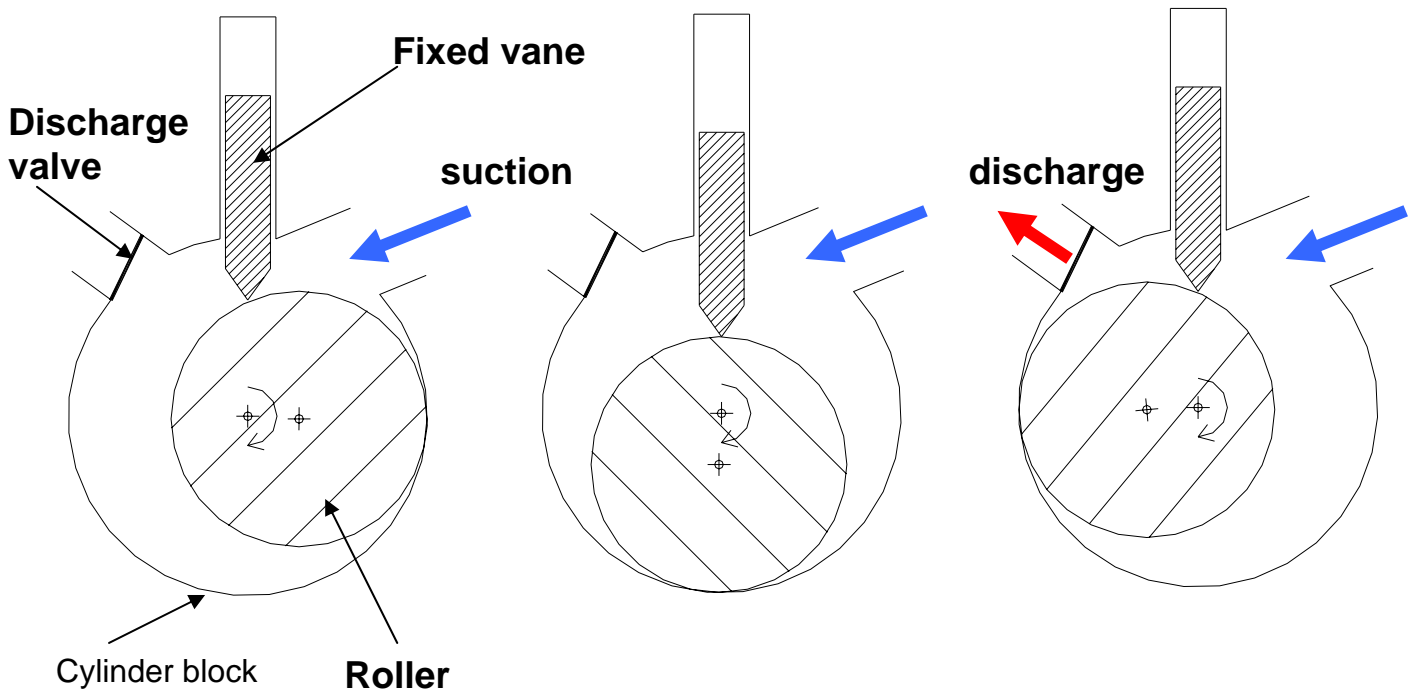
1. Discuss working principle and characteristics of a fixed vane, rolling piston type compressor (*Section 20.1*)
2. Discuss working principle and characteristics of a multiple vane, rotary compressor (*Section 20.2, 20.3*)
3. Discuss working principle and characteristics of a twin-screw type compressor (*Section 20.4.1*)
4. Discuss working principle and characteristics of a single-screw type compressor (*Section 20.4.2*)
5. Discuss working principle, characteristics and specific advantages of a scroll compressor (*Section 20.5*)

At the end of the lecture, the student should be able to

1. Explain with schematics the working principles of rotary fixed and multiple vane type compressors, single- and twin-screw type compressors and scroll compressors.
2. Explain the performance characteristics, advantages and applications of rotary, positive displacement type compressors.

### 20.1. Rolling piston (fixed vane) type compressors:

Rolling piston or fixed vane type compressors are used in small refrigeration systems (upto 2 kW capacity) such as domestic refrigerators or air conditioners. These compressors belong to the class of positive displacement type as compression is achieved by reducing the volume of the refrigerant. In this type of compressors, the rotating shaft of the roller has its axis of rotation that matches with the centerline of the cylinder, however, it is eccentric with respect to the roller (Figure 20.1). This eccentricity of the shaft with respect to the roller creates suction and compression of the refrigerant as shown in Fig.20.1. A single vane or blade is positioned in the non-rotating cylindrical block. The rotating motion of the roller causes a reciprocating motion of the single vane.



**Fig.20.1:** Working principle of a rolling piston type compressor

As shown in Fig.20.1, this type of compressor does not require a suction valve but requires a discharge valve. The sealing between the high and low pressure sides has to be provided:

- Along the line of contact between roller and cylinder block
- Along the line of contact between vane and roller, and
- between the roller and end-pates

The leakage is controlled through hydrodynamic sealing and matching between the mating components. The effectiveness of the sealing depends on the clearance, compressor speed, surface finish and oil viscosity. Close tolerances and good surface finishing is required to minimize internal leakage.

Unlike in reciprocating compressors, the small clearance volume filled with high-pressure refrigerant does not expand, but simply mixes with the suction refrigerant in the suction space. As a result, the volumetric efficiency does not reduce drastically with increasing pressure ratio, indicating small re-expansion losses. The compressor runs smoothly and is relatively quiet as the refrigerant flow is continuous.

The mass flow rate of refrigerant through the compressor is given by:

$$\dot{m} = \eta_v \left( \frac{\dot{V}_{sw}}{v_e} \right) = \left( \frac{\eta_v}{v_e} \right) \left( \frac{\pi}{4} \right) \left( \frac{N}{60} \right) (A^2 - B^2) L \quad (20.1)$$

where A = Inner diameter of the cylinder

B = Diameter of the roller

L = Length of the cylinder block

N = Rotation speed, RPM

$\eta_v$  = Volumetric efficiency

$v_e$  = specific volume of refrigerant at suction

## 20.2. Multiple vane type compressors:

As shown in Fig.20.2, in multiple vane type compressor, the axis of rotation coincides with the center of the roller ( $\mathbf{O}$ ), however, it is eccentric with respect to the center of the cylinder ( $\mathbf{O}'$ ). The rotor consists of a number of slots with sliding vanes. During the running of the compressor, the sliding vanes, which are normally made of non-metallic materials, are held against the cylinder due to centrifugal forces. The number of compression strokes produced in one revolution of the rotor is equal to the number of sliding vanes, thus a 4-vane compressor produces 4 compression strokes in one rotation.

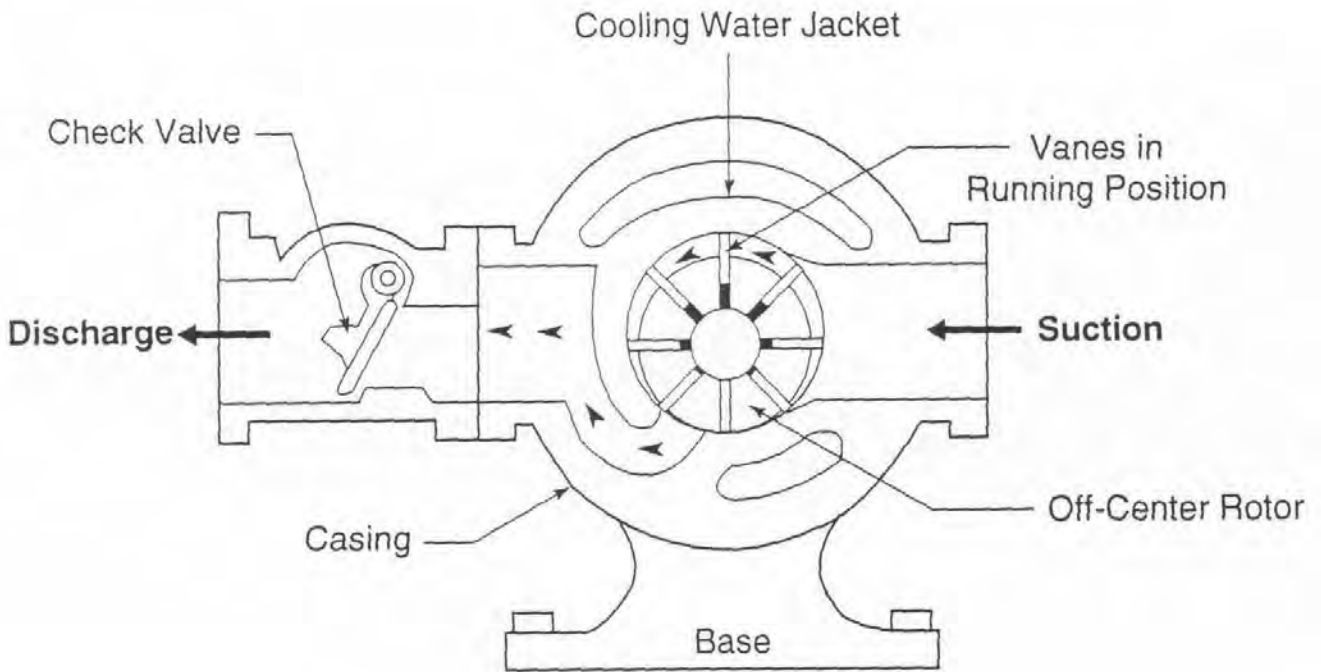
In these compressors, sealing is required between the vanes and cylinder, between the vanes and the slots on the rotor and between the rotor and the end plate. However, since pressure difference across each slot is only a fraction of the total pressure difference, the sealing is not as critical as in fixed vane type compressor.

This type of compressor does not require suction or discharge valves, however, as shown in Fig.20.3, check valves are used on discharge side to prevent reverse rotation during off-time due to pressure difference. Since there are no discharge valves, the compressed refrigerant is opened to the discharge port when it has been compressed through a fixed volume ratio, depending upon the geometry. This implies that these compressors have a fixed built-in volume ratio. The built-in volume ratio is defined as "the ratio of a cell as it is closed off from the suction port to its volume before it opens to the discharge port". Since the volume ratio is fixed, the pressure ratio,  $r_p$  is given by:

$$r_p = \left( \frac{P_d}{P_s} \right) = V_b^k \quad (20.2)$$

where  $P_d$  and  $P_s$  are the discharge and suction pressures,  $V_b$  is the built-in volume ratio and  $k$  is the index of compression.

Since no centrifugal force is present when the compressor is off, the multiple vanes will not be pressed against the cylinder walls during the off-period. As a result,

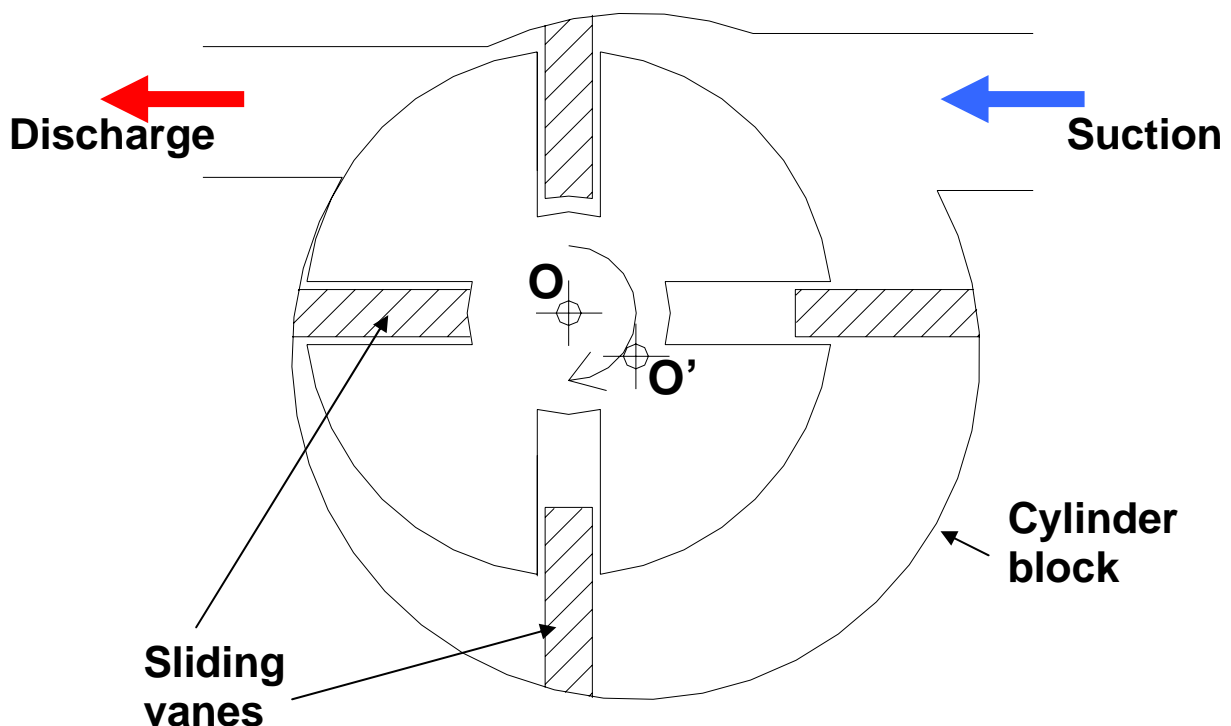


**Fig.20.3:** Sectional view of a multiple vane, rotary compressor

high pressure refrigerant from the discharge side can flow back into the side and pressure equalization between high and low pressure sides take place. This is beneficial from the compressor motor point-of-view as it reduces the required starting torque. However, this introduces cycling loss due to the entry of high pressure and hot refrigerant liquid into the evaporator. Hence, normally a non-return check valve is used on the discharge side which prevents the entry of refrigerant liquid from high pressure side into evaporator through the compressor during off-time, at the same time there will be pressure equalization across the vanes of the compressor.

### 20.3. Characteristics of rotary, vane type compressors:

Rotary vane type compressors have low mass-to-displacement ratio, which in combination with compact size makes them ideal for transport applications. The



**Fig.20.2:** Working principle of a multiple vane, rotary compressor

compressors are normally oil-flooded type, hence, oil separators are required. Both single-stage (upto  $-40^{\circ}\text{C}$  evaporator temperature and  $60^{\circ}\text{C}$  condensing temperature) and two-stage (upto  $-50^{\circ}\text{C}$  evaporator temperature) compressors with the cooling capacity in the range of 2 to 40 kW are available commercially. The cooling capacity is normally controlled either by compressor speed regulation or suction gas throttling. Currently, these compressors are available for a wide range of refrigerants such as R 22, ammonia, R 404a etc.

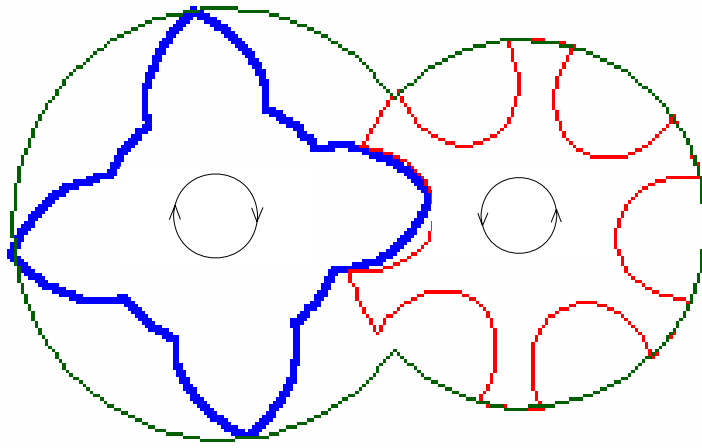
## 20.4. Rotary, screw compressors:

The rotary screw compressors can be either twin-screw type or single-screw type.

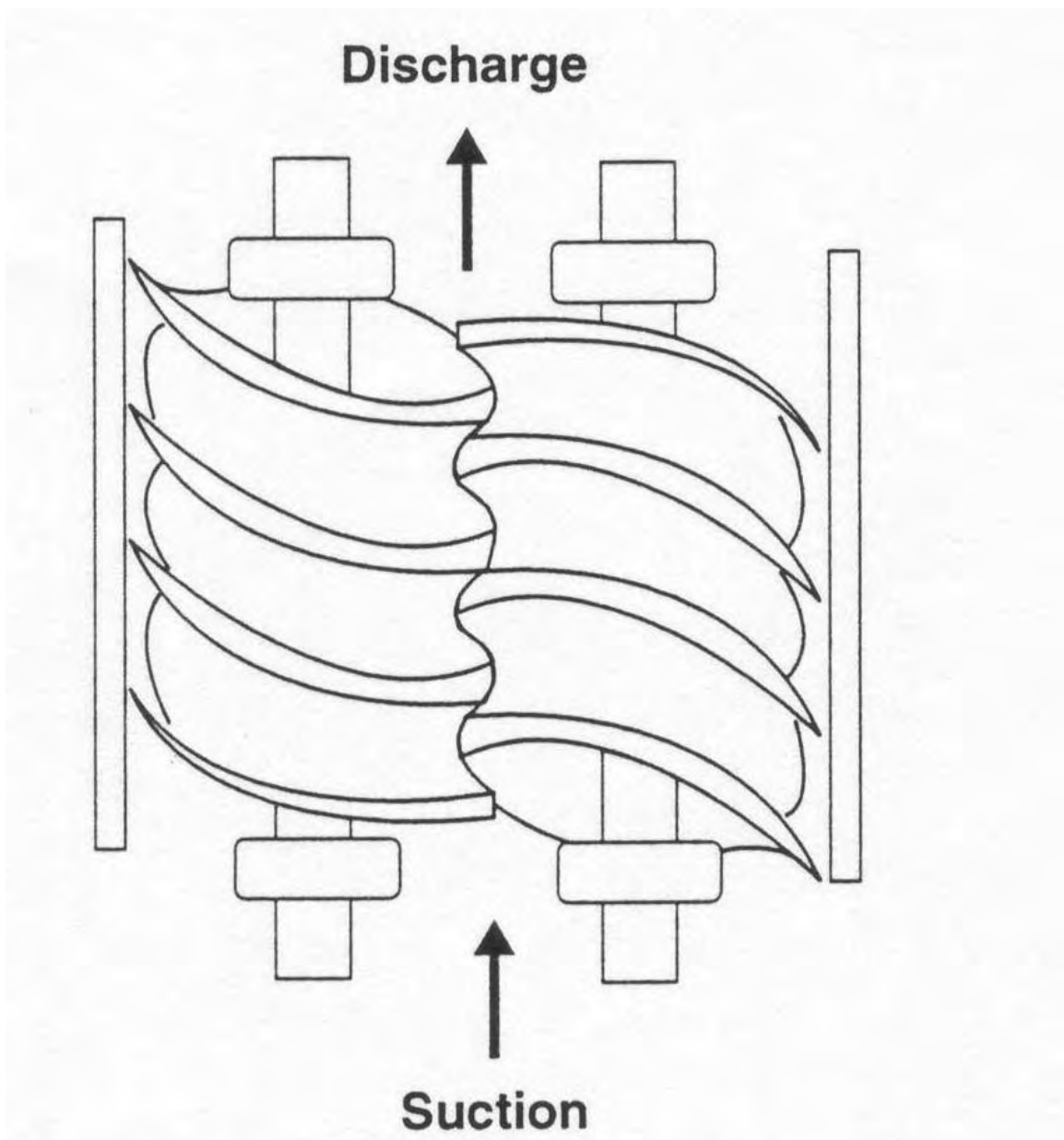
### 20.4.1. Twin-screw compressor:

The twin-screw type compressor consists of two mating helically grooved rotors, one male and the other female. Generally the male rotor drives the female rotor. The male rotor has lobes, while the female rotor has flutes or gullies. The frequently used lobe-gully combinations are [4,6], [5,6] and [5,7]. Figure 20.4 shows the [4,6] combination. For this [4,6] combination, when the male rotor rotates at 3600 RPM, the female rotor rotates at 2400 RPM.

As shown in Fig.20.5, the flow is mainly in the axial direction. Suction and compression take place as the rotors unmesh and mesh. When one lobe-gully combination begins to unmesh the opposite lobe-gully combination begins to mesh. With 4 male lobes rotating at 3600 RPM, 4 interlobe volumes are per revolution, thus giving  $4 \times 3600 = 14400$  discharges per minute.



**Fig.20.4:** Twin-screw compressor with 4 male lobes and 6 female gullies



**Fig.20.5:** Direction of refrigerant flow in a twin-screw compressor

Discharge takes place at a point decided by the designed built-in volume ratio, which depends entirely on the location of the delivery port and geometry of the compressor. Since the built-in volume ratio is fixed by the geometry, a particular compressor is designed for a particular built-in pressure ratio. However, different built-in ratios can be obtained by changing the position of the discharge port. The built-in pressure ratio,  $r_p$  given by:

$$r_p = \left( \frac{P_d}{P_s} \right) = V_b^k \quad (20.3)$$

Where  $P_d$  and  $P_s$  are the discharge and suction pressures,  $V_b$  is the built-in volume ratio and  $k$  is the index of compression.

If the built-in pressure at the end of compression is less than the condensing pressure, high pressure refrigerant from discharge manifold flows back into the interlobe space when the discharge port is uncovered. This is called as under-compression. On the other hand, if the built-in pressure at the end of compression is higher than the condensing pressure, then the compressed refrigerant rushes out in an unrestrained expansion as soon as the port is uncovered (over-compression). Both under-compression and over-compression are undesirable as they lead to loss in efficiency.

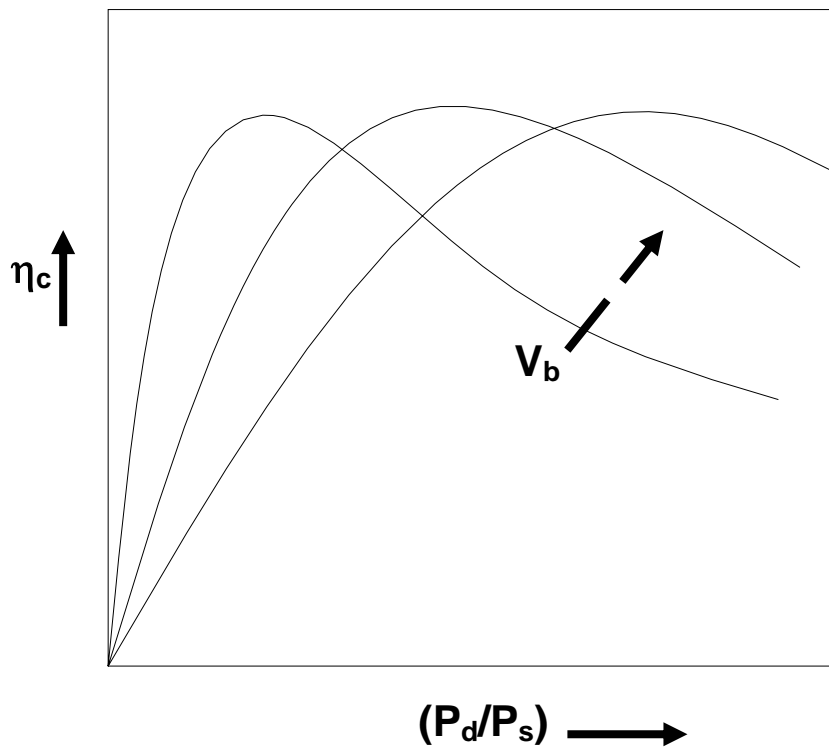
Lubrication and sealing between the rotors is obtained by injecting lubricating oil between the rotors. The oil also helps in cooling the compressor, as a result very high pressure ratios (upto 20:1) are possible without overheating the compressor.

The capacity of the screw compressor is normally controlled with the help of a slide valve. As the slide valve is opened, some amount of suction refrigerant escapes to the suction side without being compressed. This yields a smooth capacity control from 100 percent down to 10 percent of full load. It is observed that the power input is approximately proportional to refrigeration capacity upto about 30 percent, however, the efficiency decreases rapidly, there after.

Figure 20.6 shows the compression efficiency of a twin-screw compressor as a function of pressure ratio and built-in volume ratio. It can be seen that for a given built-in volume ratio, the efficiency reaches a peak at a particular optimum pressure ratio. The value of this optimum pressure ratio increases with built-in volume ratio as shown in the figure. If the design condition corresponds to the optimum pressure ratio, then the compression efficiency drops as the system operates at off-design conditions. However, when operated at the optimum pressure ratio, the efficiency is much higher than other types of compressors.

As the rotor normally rotates at high speeds, screw compressors can handle fairly large amounts of refrigerant flow rates compared to other positive displacement type compressors. Screw compressors are available in the capacity range of 70 to 4600 kW. They generally compete with high capacity reciprocating compressors and low capacity centrifugal compressors. They are available for a wide variety of refrigerants and applications. Compared to reciprocating compressors, screw compressors are balanced and hence do not suffer from vibration problems.





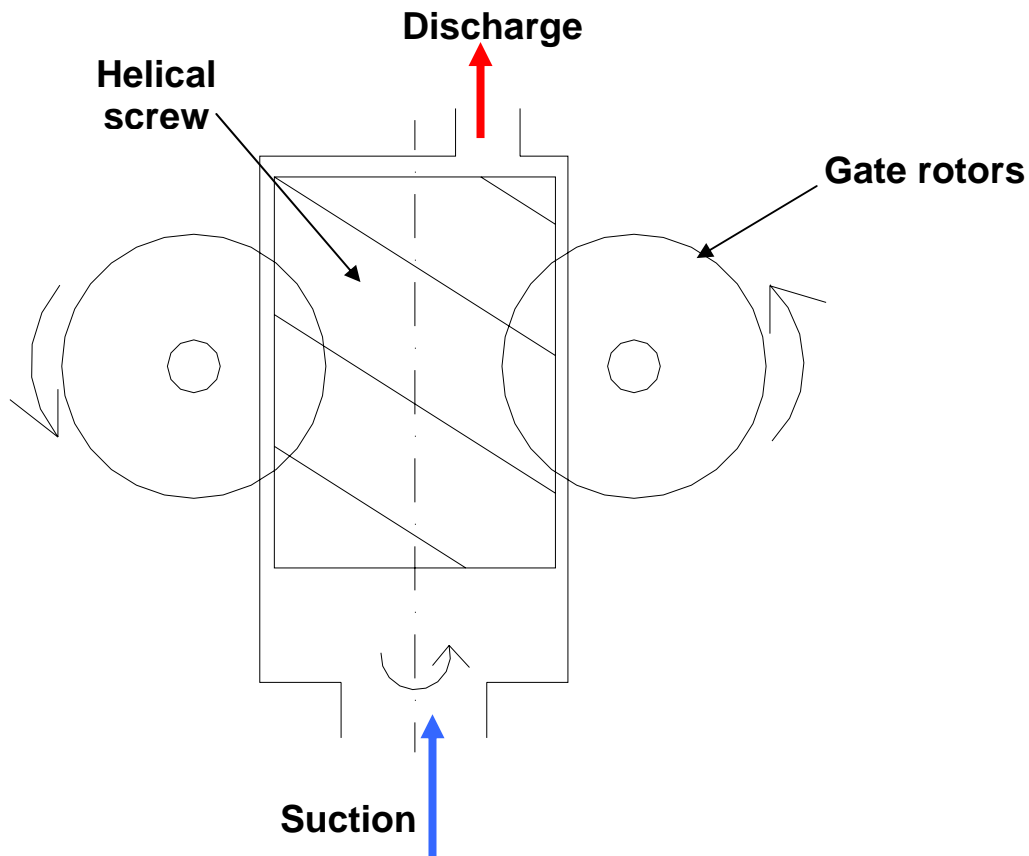
**Fig.20.6:** Variation of compression efficiency of a twin-screw compressor with pressure ratio and built-in volume ratio

Twin-screw compressors are rugged and are shown to be more reliable than reciprocating compressors; they are shown to run for 30000 – 40000 hours between major overhauls. They are compact compared to reciprocating compressors in the high capacity range.

#### 20.4.2. Single-screw compressors:

As the name implies, single screw compressors consist of a single helical screw and two planet wheels or gate rotors. The helical screw is housed in a cylindrical casing with suction port at one end and discharge port at the other end as shown in Fig. 20.7. Suction and compression are obtained as the screw and gate rotors unmesh and mesh. The high and low pressure regions in the cylinder casing are separated by the gate rotors.

The single screw is normally driven by an electric motor. The gate rotors are normally made of plastic materials. Very small power is required to rotate the gate rotors as the frictional losses between the metallic screw and the plastic gate rotors is very small. It is also possible to design the compressors with a single gate rotor. Similar to twin-screw, lubrication, sealing and compressor cooling is achieved by injecting lubricating oil into the compressor. An oil separator, oil cooler and pump are required to circulate the lubricating oil. It is also possible to achieve this by injecting liquid refrigerant, in which case there is no need for an oil separator.



**Fig.20.7:** Working principle of a single-screw compressor

## 20.5. Scroll compressors:

Scroll compressors are orbital motion, positive displacement type compressors, in which suction and compression is obtained by using two mating, spiral shaped, scroll members, one fixed and the other orbiting. Figure 20.8 shows the working principle of scroll compressors. Figures 20.9 and 20.10 show the constructional details of scroll compressors. As shown in Fig.20.8, the compression process involves three orbits of the orbiting scroll. In the first orbit, the scrolls ingest and trap two pockets of suction gas. During the second orbit, the two pockets of gas are compressed to an intermediate pressure. In the final orbit, the two pockets reach discharge pressure and are simultaneously opened to the discharge port. This simultaneous process of suction, intermediate compression, and discharge leads to the smooth continuous compression process of the scroll compressor. One part that is not shown in this diagram but is essential to the operation of the scroll is the anti-rotation coupling. This device maintains a fixed angular relation of 180 degrees between the fixed and orbiting scrolls. This fixed angular relation, coupled with the movement of the orbiting scroll, is the basis for the formation of gas compression pockets.

As shown in Figs.20.9 and 20.10, each scroll member is open at one end and bound by a base plate at the other end. They are fitted to form pockets of refrigerant between their respective base plates and various lines of contacts between the scroll walls. Compressor capacity is normally controlled by variable speed inverter drives.

SUCTION



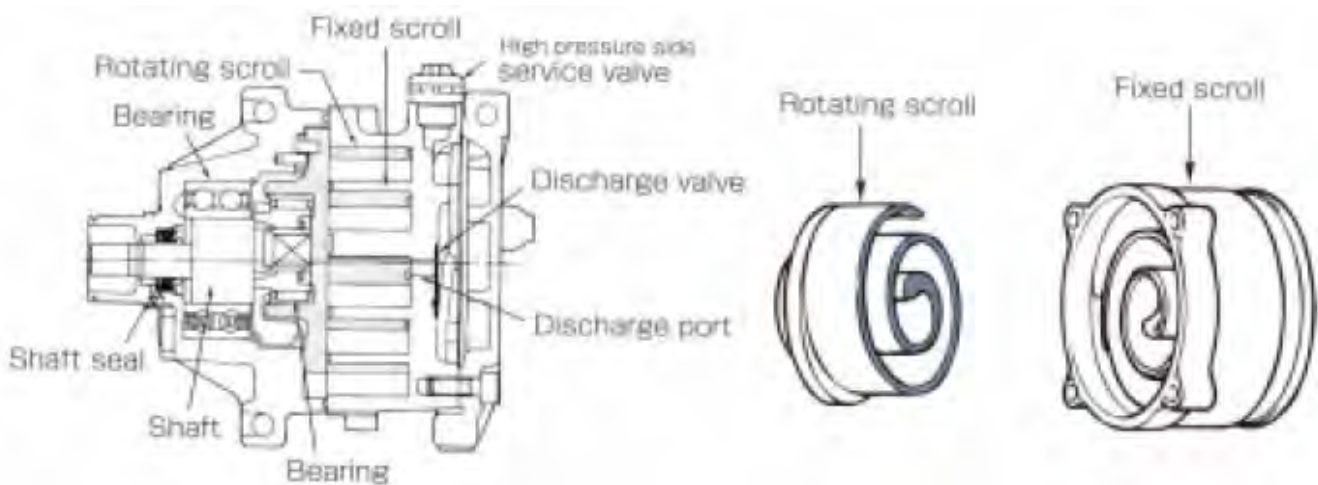
COMPRESSION



DISCHARGE



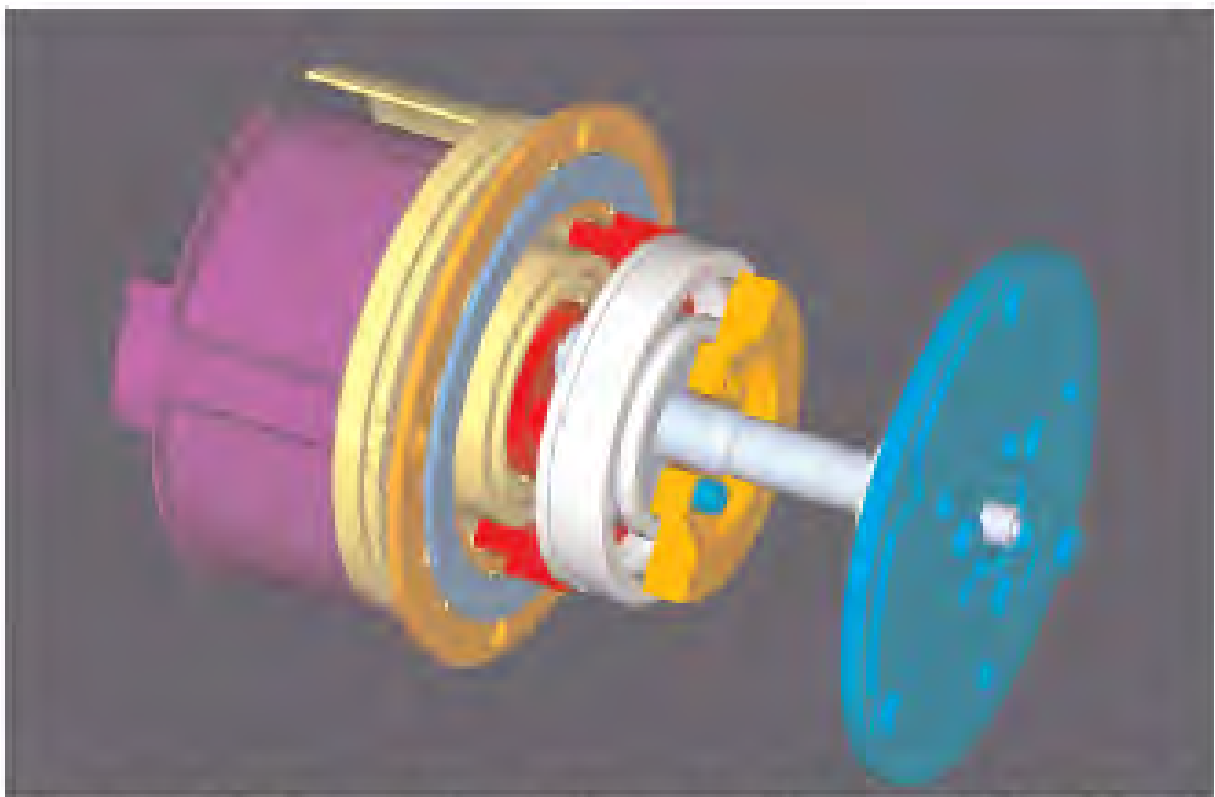
**Fig.20.8:** Working principle of a scroll compressor



**Fig.20.9:** Main parts of a scroll compressor



This graphic shows the two spiral-shaped intermeshing scrolls.



The graphic shown above shows a side view of the interior components of the scroll compressor.

**Fig.20.10:** Different views of a scroll compressor

Currently, the scroll compressors are used in small capacity (3 to 50 kW) refrigeration, air conditioning and heat pump applications. They are normally of hermetic type. Scroll compressors offer several advantages such as:

1. Large suction and discharge ports reduce pressure losses during suction and discharge
2. Physical separation of suction and compression reduce heat transfer to suction gas, leading to high volumetric efficiency
3. Volumetric efficiency is also high due to very low re-expansion losses and continuous flow over a wide range of operating conditions
4. Flatter capacity versus outdoor temperature curves
5. High compression efficiency, low noise and vibration compared to reciprocating compressors
6. Compact with minimum number of moving parts

## Questions and Answers:

1. Which of the following statements concerning fixed vane, rotary compressors are true?

- a) These compressors are used in small capacity systems (less than 2 kW)
- b) They require suction valve, but do not require discharge valve
- c) Refrigerant leakage is minimized by hydrodynamic lubrication
- d) Compared to reciprocating compressors, the re-expansion losses are high in rotary vane compressor

**Ans.: a) and c)**

2. Which of the following statements concerning multiple vane, rotary compressors are true?

- a) Compared to fixed vane compressors, the leakage losses are less in multiple vane compressors
- b) Multiple vane compressors do not require suction and discharge valves
- c) A non-return, check valve is used on suction side of the compressor to minimize cycling losses
- d) All of the above

**Ans.: d)**

3. Which of the following statements concerning rotary vane type compressors are not true?

- a) They are compact due to high volumetric efficiency
- b) They are ideal for transport applications due to low mass-to-capacity ratio
- c) They are easier to manufacture compared to reciprocating compressors
- d) They are better balanced, and hence, offer lower noise levels

**Ans.: c)**

4. For a twin-screw type compressors with 5 male lobes and a rotational speed of 3000 RPM, the number of discharges per minute are:

- a) 600
- b) 15000
- c) 1200
- d) 3000

**Ans.: b)**

5. Twin-screw compressors can be operated at high pressure ratios because:

- a) These compressors are designed to withstand high discharge temperatures
- b) Lubricating oil, which also acts as a coolant is injected between the rotors
- c) The cold suction gas cools the rotors during suction stroke
- d) All of the above

**Ans.: b)**

6. Which of the following statements concerning screw compressors are true?

- a) Compared to reciprocating compressors, screw compressors are rugged and are more reliable
- b) Screw compressors are easier to manufacture and are cheaper compared to reciprocating compressors
- c) The compression efficiency of a screw compressor increases with built-in volume ratio
- d) Screw compressors are available in refrigeration capacity ranging from fractional kilowatts to megawatts

**Ans.: a)**

7. Which of the following statements concerning screw compressors are true?

- a) The capacity of a screw compressor can be varied over a large range by using the slide valve
- b) Compared to reciprocating compressors, screw compressors are compact for small capacities and bulky for large capacities
- c) An oil separator and an oil cooler are required in a screw compressor irrespective of the type of refrigerant used
- d) Vibration is one of the practical problems in operating screw compressors

**Ans.: a) and c)**

8. Which of the following statements concerning scroll compressors are true:

- a) Currently available scroll compressors are of open type
- b) Currently scroll compressors are available for large capacities only
- c) The possibility of suction gas heating is less in scroll compressors
- d) Scroll compressors are easier to manufacture

**Ans.: c)**

9. The advantages of scroll compressors are:

- a) High volumetric efficiency
- b) Capacity is less sensitive to outdoor conditions
- c) Compactness
- d) Low noise and vibration
- e) All of the above

**Ans.: e)**

# Lesson

## 21

# Centrifugal Compressors



## The specific objectives of this lesson are to:

1. Explain the working principle of a centrifugal compressor (*Section 21.1*)
2. Present the analysis of centrifugal compressors (*Section 21.2*)
3. Discuss the selection of impeller diameter and speed of a centrifugal compressor using velocity diagrams (*Section 21.3*)
4. Discuss the effect of blade width on the capacity of centrifugal compressor (*Section 21.4*)
5. Discuss the methods of capacity control of a centrifugal compressor (*Section 21.5*)
6. Discuss the performance aspects and the phenomenon of surging in centrifugal compressors (*Section 21.6*)
7. Compare the performance of a centrifugal compressor with a reciprocating compressor vis-à-vis condensing and evaporator temperatures and compressor speed (*Section 21.6*)
8. Describe commercial refrigeration systems using centrifugal compressors (*Section 21.7*)

At the end of the lecture, the student should be able to:

1. Explain the working principle of a centrifugal compressor with suitable diagrams
2. Analyse the performance of a centrifugal compressor using steady flow energy equation and velocity diagrams
3. Calculate the required impeller diameter and/or speed of a centrifugal compressor
4. Explain the limitations on minimum refrigeration capacity of centrifugal compressors using velocity diagrams
5. Explain the methods of capacity control of centrifugal compressor
6. Explain the phenomenon of surging
7. Compare the performance aspects of centrifugal and reciprocating compressors

### 21.1. Introduction:

Centrifugal compressors; also known as turbo-compressors belong to the roto-dynamic type of compressors. In these compressors the required pressure rise takes place due to the continuous conversion of angular momentum imparted to the refrigerant vapour by a high-speed impeller into static pressure. Unlike reciprocating compressors, centrifugal compressors are steady-flow devices hence they are subjected to less vibration and noise.

Figure 21.1 shows the working principle of a centrifugal compressor. As shown in the figure, low-pressure refrigerant enters the compressor through the eye of the impeller (1). The impeller (2) consists of a number of blades, which

form flow passages (3) for refrigerant. From the eye, the refrigerant enters the flow passages formed by the impeller blades, which rotate at very high speed. As the refrigerant flows through the blade passages towards the tip of the impeller, it gains momentum and its static pressure also increases. From the tip of the impeller, the refrigerant flows into a stationary diffuser (4). In the diffuser, the refrigerant is decelerated and as a result the dynamic pressure drop is converted into static pressure rise, thus increasing the static pressure further. The vapour from the diffuser enters the volute casing (5) where further conversion of velocity into static pressure takes place due to the divergent shape of the volute. Finally, the pressurized refrigerant leaves the compressor from the volute casing (6).

The gain in momentum is due to the transfer of momentum from the high-speed impeller blades to the refrigerant confined between the blade passages. The increase in static pressure is due to the self-compression caused by the centrifugal action. This is analogous to the gravitational effect, which causes the fluid at a higher level to press the fluid below it due to gravity (or its weight). The static pressure produced in the impeller is equal to the static head, which would be produced by an equivalent gravitational column. If we assume the impeller blades to be radial and the inlet diameter of the impeller to be small, then the static head,  $h$  developed in the impeller passage for a single stage is given by:

$$h = \frac{V^2}{g} \quad (21.1)$$

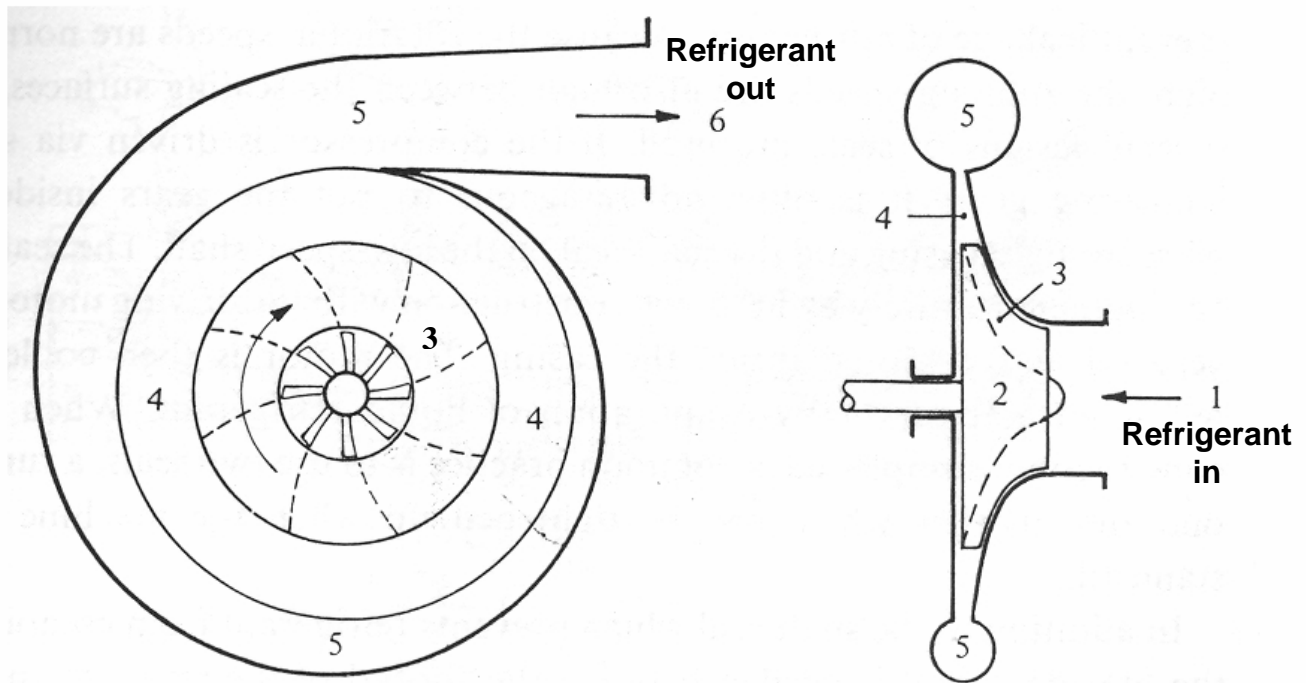
where  $h$  = static head developed, m

$V$  = peripheral velocity of the impeller wheel or tip speed, m/s

$g$  = acceleration due to gravity,  $m/s^2$

Hence increase in total pressure,  $\Delta P$  as the refrigerant flows through the passage is given by:

$$\Delta P = \rho g h = \rho V^2 \quad (21.2)$$



### 21.1. Centrifugal Compressor

1: Refrigerant inlet (eye); 2: Impeller; 3: Refrigerant passages  
4: Vaneless diffuser; 5: Volute casing; 6: Refrigerant discharge

Thus it can be seen that for a given refrigerant with a fixed density, the pressure rise depends only on the peripheral velocity or tip speed of the blade. The tip speed of the blade is proportional to the rotational speed (RPM) of the impeller and the impeller diameter. The maximum permissible tip speed is limited by the strength of the structural materials of the blade (usually made of high speed chrome-nickel steel) and the sonic velocity of the refrigerant. Under these limitations, the maximum achievable pressure rise (hence maximum achievable temperature lift) of single stage centrifugal compressor is limited for a given refrigerant. Hence, multistage centrifugal compressors are used for large temperature lift applications. In multistage centrifugal compressors, the discharge of the lower stage compressor is fed to the inlet of the next stage compressor and so on. In multistage centrifugal compressors, the impeller diameter of all stages remains same, but the width of the impeller becomes progressively narrower in the direction of flow as refrigerant density increases progressively.

The blades of the compressor or either forward curved or backward curved or radial. Backward curved blades were used in the older compressors, whereas the modern centrifugal compressors use mostly radial blades.

The stationary diffuser can be vaned or vaneless. As the name implies, in vaned diffuser vanes are used in the diffuser to form flow passages. The vanes

can be fixed or adjustable. Vaned diffusers are compact compared to the vaneless diffusers and are commonly used for high discharge pressure applications. However, the presence of vanes in the diffusers can give rise to shocks, as the refrigerant velocities at the tip of the impeller blade could reach sonic velocities in large, high-speed centrifugal compressors. In vaneless diffusers the velocity of refrigerant in the diffuser decreases and static pressure increases as the radius increases. As a result, for a required pressure rise, the required size of the vaneless diffuser could be large compared to vaned diffuser. However, the problem of shock due to supersonic velocities at the tip does not arise with vaneless diffusers as the velocity can be diffused smoothly.

Generally adjustable guide vanes or pre-rotation vanes are added at the inlet (eye) of the impeller for capacity control.

## 21.2. Analysis of centrifugal compressors:

Applying energy balance to the compressor (Fig.24.2), we obtain from steady flow energy equation:

$$-Q + m\left(h_i + \frac{V_i^2}{2} + gZ_i\right) = -W_c + m\left(h_e + \frac{V_e^2}{2} + gZ_e\right) \quad (21.3)$$

where Q = heat transfer rate from the compressor  
W = work transfer rate to the compressor  
m = mass flow rate of the refrigerant  
 $V_i, V_e$  = Inlet and outlet velocities of the refrigerant  
 $Z_i, Z_e$  = Height above a datum in gravitational force field at inlet and outlet

Neglecting changes in kinetic and potential energy, the above equation becomes:

$$-Q + mh_i = -W_c + mh_e \quad (21.4)$$

In a centrifugal compressor, the heat transfer rate Q is normally negligible (as the area available for heat transfer is small) compared to the other energy terms, hence the rate of compressor work input for adiabatic compression is given by:

$$W_c = m(h_e - h_i) \quad (21.5)$$

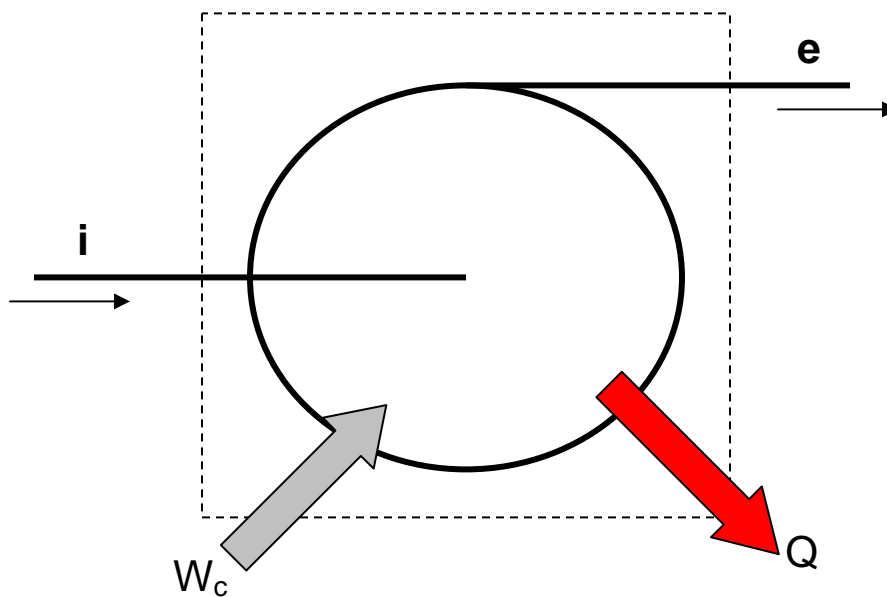
The above equation is valid for both reversible as well as irreversible adiabatic compression, provided the actual enthalpy is used at the exit in case of irreversible compression. In case of reversible, adiabatic compression, the power input to the compressor is given by:

$$W_{c,isen} = m(h_e - h_i)_{isen} \quad (21.6)$$

then using the thermodynamic relation,  $Tds=dh-vdp$ ; the isentropic work of compression is given by:

$$w_{c,isen} = (h_e - h_i)_{isen} = \int_{P_i}^{P_e} v dp|_{isen} \quad (21.7)$$

Thus the expression for reversible, isentropic work of compression is same for both reciprocating as well as centrifugal compressors. However, the basic difference between actual reciprocating compressors and actual centrifugal compressors lies in the source of irreversibility.



**Fig.21.2.** Energy balance across a compressor

In case of reciprocating compressors, the irreversibility is mainly due to heat transfer and pressure drops across valves and connecting pipelines. However, in case of centrifugal compressors, since the refrigerant has to flow at very high velocities through the impeller blade passages for a finite pressure rise, the major source of irreversibility is due to the viscous shear stresses at the interface between the refrigerant and the impeller blade surface.

In reciprocating compressors, the work is required to overcome the normal forces acting against the piston, while in centrifugal compressors, work is required to overcome both normal pressure forces as well as viscous shear forces. The specific work is higher than the area of P-v diagram in case of centrifugal compressors due to irreversibilities and also due to the continuous increase of specific volume of refrigerant due to fluid friction.

To account for the irreversibilities in centrifugal compressors, a polytropic efficiency  $\eta_{pol}$  is defined. It is given by:

$$\eta_{pol} = \frac{w_{pol}}{w_{act}} = \frac{\int_{P_i}^{P_e} v dp}{(h_e - h_i)} \quad (21.8)$$

where  $w_{pol}$  and  $w_{act}$  are the polytropic and actual works of compression, respectively.

The polytropic work of compression is usually obtained by the expression:

$$w_{pol} = \int_{P_i}^{P_e} v dP = f \left( \frac{n}{n-1} \right) P_i v_i \left[ \left( \frac{P_e}{P_i} \right)^{\frac{n-1}{n}} - 1 \right] \quad (21.9)$$

where  $n$  is the index of compression,  $f$  is a correction factor which takes into account the variation of  $n$  during compression. Normally the value of  $f$  is close to 1 (from 1.00 to 1.02), hence it may be neglected in calculations, without significant errors.

If the refrigerant vapour is assumed to behave as an ideal gas, then it can be shown that the polytropic efficiency is equal to:

$$\eta_{pol} = \left( \frac{n}{n-1} \right) \left( \frac{\gamma-1}{\gamma} \right) \quad (21.10)$$

where  $\gamma$  = specific heat ratio,  $c_p/c_v$  (assumed to be constant).

Though refrigerant vapours do not strictly behave as ideal gases, the above simple equation is often used to obtain the polytropic efficiency of the centrifugal compressors by replacing  $\gamma$  by isentropic index of compression,  $k$ , i.e., for actual refrigerants the polytropic efficiency is estimated from the equation:

$$\eta_{pol} = \left( \frac{n}{n-1} \right) \left( \frac{k-1}{k} \right) \quad (21.11)$$

For actual centrifugal compressors, the polytropic efficiency is found to lie in the range of 0.7 to 0.85. The index of compression  $n$  is obtained from actual measurements of pressures and specific volumes at the inlet and exit of the compressor and then using the equation  $Pv^n = \text{constant}$ . This procedure usually gives fairly accurate results for refrigerants made of simple molecules such as water, ammonia. The deviation between actual efficiency and polytropic

efficiency evaluated using the above equations can be significant in case of heavier molecules such as R 22, R 134a.

When the refrigerant velocities are high, then the change in kinetic energy across the compressor can be considerable. In such cases, these terms have to be included in the steady flow energy equation. If the heat transfer rate is negligible and change in kinetic energy is considerable, then the rate of work input to the compressor is given by:

$$W_c = m(h_{t,e} - h_{t,i}) \quad (21.12)$$

where  $h_{t,e}$  and  $h_{t,i}$  are the total or stagnation enthalpies at the exit and inlet to the compressor, respectively. The stagnation enthalpy of the refrigerant  $h_t$  is given by:

$$h_t = h + \frac{V^2}{2} \quad (21.13)$$

where  $h$  is the specific enthalpy of the refrigerant and  $V$  is its velocity. Similar to stagnation enthalpy, one can also define stagnation temperature and stagnation pressure. The stagnation pressure  $P_t$  is defined as the pressure developed as the refrigerant is decelerated reversibly and adiabatically from velocity  $V$  to rest. Then from energy balance,

$$\int_P^{P_t} v dp|_{isen} = h_t - h = \frac{V^2}{2} \quad (21.14)$$

Stagnation pressure and temperature of moving fluids can be measured by pressure and temperature sensors moving with the fluid at the same velocity.

For an ideal gas:

$$(h_t - h) = \frac{V^2}{2} = C_p(T_t - T) \quad (21.15)$$

where  $T_t$  is the total or stagnation temperature given by:

$$T_t = T + \frac{V^2}{2C_p} \quad (21.16)$$

where  $T$  is the static temperature and  $C_p$  is the specific heat at constant pressure.

For an incompressible fluid (density  $\approx$  constant):

$$\int_P^{P_t} v dp|_{\text{isen}} = \frac{V^2}{2} \approx v(P_t - P) \quad (21.17)$$

hence the stagnation pressure of an incompressible fluid is given by:

$$P_t = P + \frac{1}{2} \frac{V^2}{v} \quad (21.18)$$

### 21.3. Selection of impeller speed and impeller diameter:

As the refrigerant vapour flows from the suction flange to the inlet to the impeller, its stagnation enthalpy remains constant as no work is done during this section. However, the velocity of the refrigerant may increase due to reduction in flow area. Depending upon the presence or absence of inlet guide vanes in the eye of the impeller, the refrigerant enters the impeller with a pre-rotation or axially. Then the direction of the refrigerant changes by  $90^\circ$  as it enters the flow passages between the impeller blades from the inlet. As the refrigerant flows through the blade passages its stagnation enthalpy rises as work of compression is supplied to the refrigerant through the impeller blades. Simultaneously its velocity and static pressure rise due to the momentum transfer and self-compression. However, the relative velocity between refrigerant and impeller blades usually reduces as the refrigerant flows towards the tip. From the tip of the impeller the refrigerant enters the diffuser, where its static pressure increases further due to deceleration, however, its total enthalpy remains constant as no energy transfer takes place to the refrigerant. From the diffuser the refrigerant enters the volute casing where further pressure rise takes place due to conversion of velocity into static pressure, while the total enthalpy remains constant as no energy is added to the refrigerant in the volute casing. Thus the total enthalpy of the refrigerant remains constant everywhere except across the impeller. To establish a relation between the power input and the impeller speed and diameter, it is essential to find the torque required to rotate the impeller. This calls for application of conservation of angular momentum equation to the refrigerant across the impeller.

Figure 21.3 shows the velocity diagram at the outlet of the impeller. The torque required to rotate the impeller is equal to the rate of change of the angular momentum of the refrigerant. Assuming the refrigerant to enter the impeller blade passage radially with no tangential component at inlet, the torque  $\tau$  is given by:

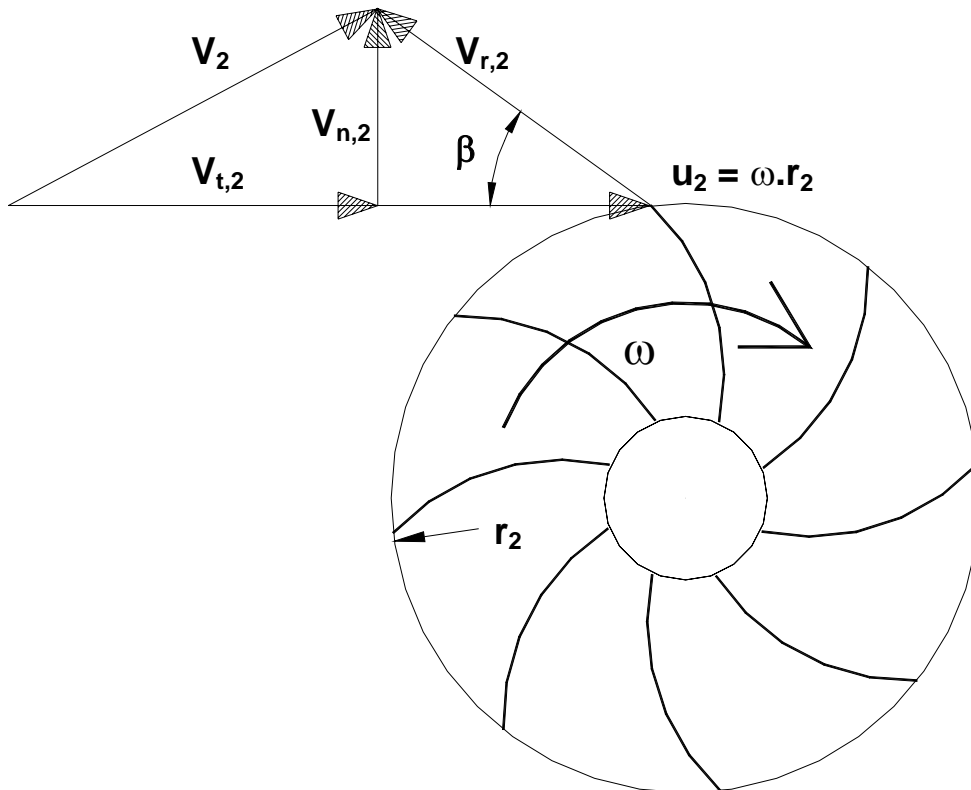
$$\tau = m r_2 V_{t,2} \quad (21.19)$$



where  $m$  is the mass flow rate of the refrigerant,  $r_2$  is the outer radius of the impeller blade and  $V_{t,2}$  is the tangential component of the absolute refrigerant velocity  $V_2$  at impeller exit. The power input to the impeller  $W$  is given by:

$$P = \tau \cdot \omega = m r_2 \omega V_{t,2} = m u_2 V_{t,2} \quad (21.20)$$

where  $u_2$  is the tip speed of the impeller blade =  $\omega \cdot r_2$ .  $\omega$  is the rotational speed in radians/s and  $r_2$  is the impeller blade radius.



$u_2$	= $\omega \cdot r_2$ = Tip speed of the impeller
$\omega$	= Rotational speed of impeller
$V_2$	= Absolute velocity of fluid
$V_{r,2}$	= Relative velocity of fluid w.r.t to the impeller
$V_{t,2}$	= Tangential component of $V_2$
$V_{n,2}$	= Normal component of $V_2$

**21.3:** Velocity diagram at the outlet of the impeller of a centrifugal compressor

The velocity diagram also shows the normal component of refrigerant velocity,  $V_{n,2}$  at the impeller outlet. The volume flow rate from the impeller is proportional to the normal component of velocity. From the velocity diagram the tangential component  $V_{t,2}$  can be written in terms of the tip speed  $u_2$ , normal component  $V_{n,2}$  and the outlet blade angle  $\beta$  as:

$$V_{t,2} = u_2 - V_{n,2} \cot \beta = u_2 \left( 1 - \frac{V_{n,2} \cot \beta}{u_2} \right) \quad (21.21)$$

Hence the power input to the impeller,  $W$  is given by:

$$W = m u_2 V_{t,2} = m u_2^2 \left( 1 - \frac{V_{n,2} \cot \beta}{u_2} \right) \quad (21.22)$$

Thus the power input to the compressor depends on the blade angle  $\beta$ . The blade angle will be less than  $90^\circ$  for backward curved blade, equal to  $90^\circ$  for radial blades and greater than  $90^\circ$  for forward curved blade. Thus for a given impeller tip speed, the power input increases with the blade angle  $\beta$ .

If the blades are radial, then the power input is given by:

$$W = m u_2^2 \left( 1 - \frac{V_{n,2} \cot \beta}{u_2} \right) = m u_2^2; \text{ for } \beta = 90^\circ \quad (21.23)$$

If the compression process is reversible and adiabatic, then power input can also be written as:

$$W_{c,isen} = m(h_e - h_i)_{isen} = m \int_{P_i}^{P_e} v dp|_{isen} \quad (21.24)$$

Comparing the above two equations:

$$(h_e - h_i)_{isen} = \int_{P_i}^{P_e} v dp|_{isen} = u_2^2 = (\omega r_2)^2 \quad (21.25)$$

The above equation can also be written as:

$$\int_{P_i}^{P_e} v dp|_{isen} = \left( \frac{k}{k-1} \right) P_i v_i \left[ \left( \frac{P_e}{P_i} \right)^{\frac{k-1}{k}} - 1 \right] = (\omega r_2)^2 \quad (21.26)$$

Thus from the above equation, the pressure ratio,  $r_p = (P_e/P_i)$  can be written as:

$$r_p = \left( \frac{P_e}{P_i} \right) = \left[ 1 + \left( \frac{k-1}{k} \right) \left( \frac{1}{P_i v_i} \right) (\omega r_2)^2 \right]^{\frac{k}{k-1}} \quad (21.27)$$

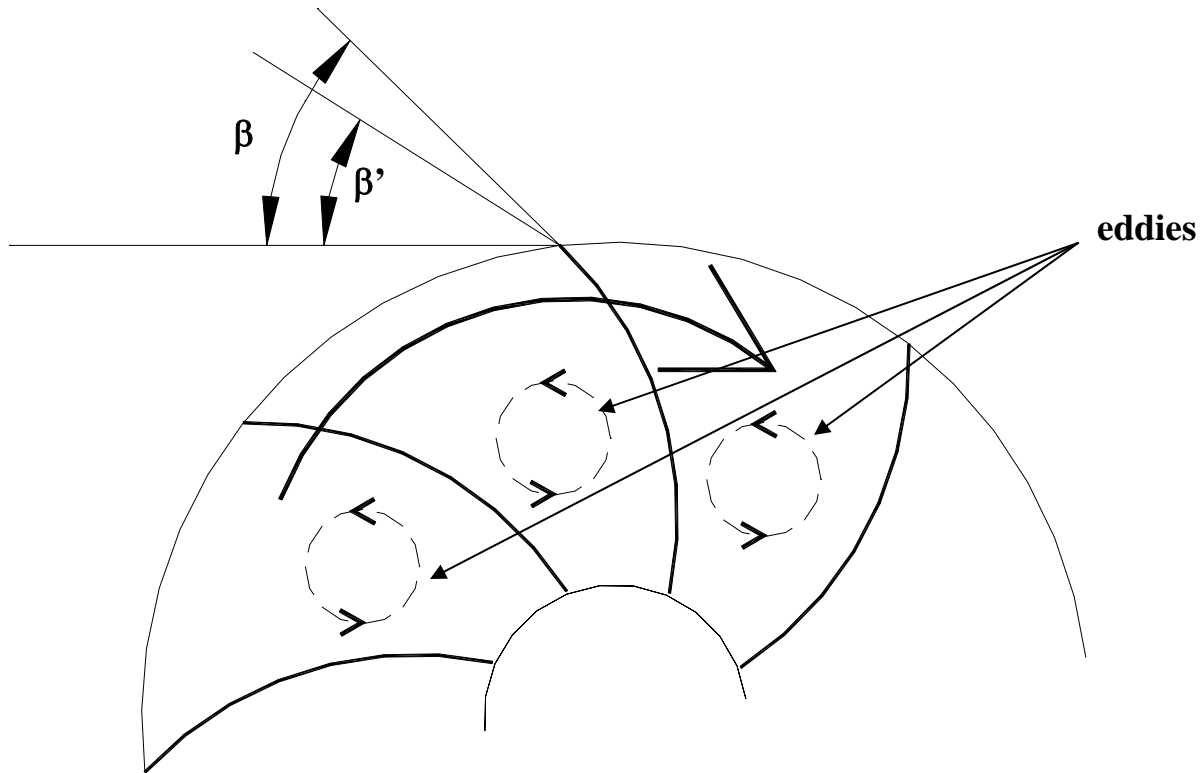
Thus it can be seen from the above expression that for a given refrigerant at a given suction conditions (i.e., fixed  $k$ ,  $P_i$  and  $v_i$ ), pressure ratio is proportional to the rotational speed of the compressor and the impeller blade diameter. Hence, larger the required temperature lift (i.e., larger pressure ratio) larger should be the rotational speed and/or impeller diameter.

Generally from material strength considerations the tip speed,  $u_2 (= \omega r_2)$  is limited to about 300 m/s. This puts an upper limit on the temperature lift with a single stage centrifugal compressor. Hence, for larger temperature lifts require multi-stage compression. For a given impeller rotational speed and impeller diameter, the pressure rise also depends on the type of the refrigerant used.

For example, for a single stage saturated cycle operating between an evaporator temperature of  $0^\circ\text{C}$  and a condensing temperature of  $32^\circ\text{C}$ , the required tip speed [ $V_{t,2} = (h_e - h_i)_{\text{isen}}^{1/2}$ ] will be 145.6 m/s in case of R134a and 386 m/s in case of ammonia. If the impeller rotates at 50 rps, then the required impeller radius would be 0.4635m in case of R 134a and 1.229m in case of ammonia. In general smaller tip speeds and impeller size could be obtained with higher normal boiling point refrigerants. This is the reason behind the wide spread use of R 11 (NBP =  $23.7^\circ\text{C}$ ) in centrifugal compressors prior to its ban.

Similar type of analyses can be carried out for other types of blades (i.e., forward or backward) and also with a pre-rotation at impeller inlet (i.e.,  $V_{t,1} \neq 0$ ). However, the actual analyses can be quite complicated if one includes the pre-rotation guide vanes, slip between the refrigerant and impeller blades etc.

In actual compressors, the angle at which fluid leaves the impeller  $\beta'$  will be different from the blade angle  $\beta$ . This is attributed to the internal circulation of refrigerant in the flow passages between the impeller blades. As the refrigerant flows outwards along a rotating radius, a pressure gradient is developed across the flow passage due to the Coriolis component of acceleration. Due to this pressure difference, eddies form in the flow channels as shown in Fig.21.4. As shown, these eddies rotate in a direction opposite to that of the impeller, as a result the actual angle  $\beta'$  at which the refrigerant leaves the impeller will be less than the blade angle  $\beta$ . Due to this, the tangential component of velocity  $V_{t,2}$  reduces, which in turn reduces the pressure rise and also the volumetric flow rate of refrigerant. The ratio of actual tangential velocity component ( $V_{t,\text{act}}$ ) to the tangential component without eddy formation ( $V_{t,2}$ ) is known as slip factor. The slip factor can be increased by increasing the number of blades (i.e., by decreasing the area of individual flow passages), however, after a certain number of blades, the efficiency drops due increased frictional losses. Hence, the number of blades are normally optimized considering the slip factor and frictional losses.



**Fig.21.4:** Formation of eddies in a backward curved centrifugal compressor

## 21.4. Refrigerant capacity of centrifugal compressors:

The refrigerant capacity of a centrifugal compressor depends primarily on the tip speed and width of the impeller. For a given set of condenser and evaporator temperatures the required pressure rise across the compressor remains same for all capacities, large and small. Since the pressure rise depends on the impeller diameter, number of impellers and rotational speed of the impeller, these parameters must remain same for all compressors of all capacities operating between the same condenser and evaporator temperatures.

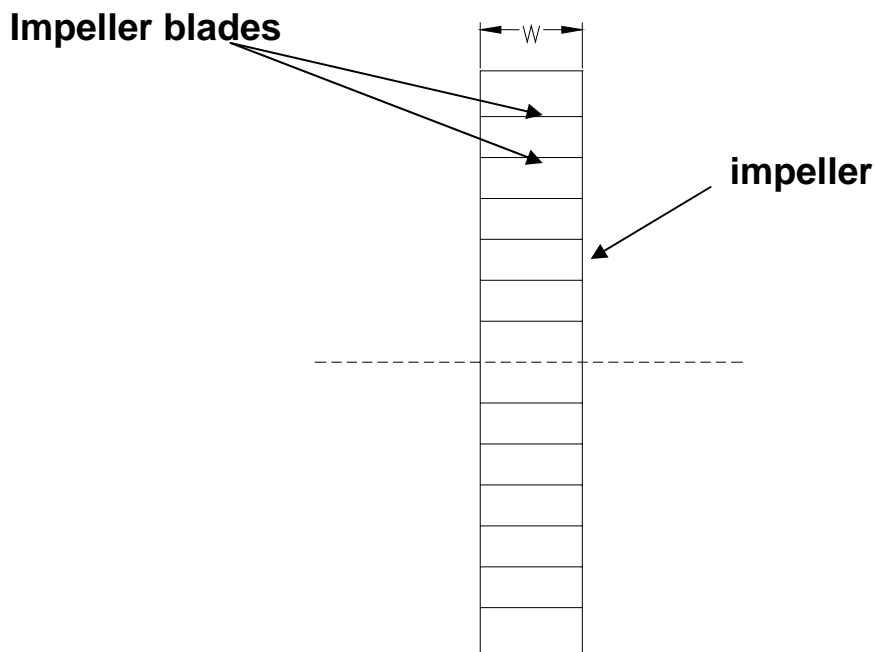
The mass flow rate through a centrifugal compressor can be written as:

$$m = \frac{V_{n,2} A_{f,p}}{v_2} \quad (21.28)$$

where  $V_{n,2}$  = Normal component of velocity at the exit  
 $A_{f,p}$  = Flow area at the periphery  
 $v_2$  = Specific volume of the refrigerant at the periphery

For a given blade diameter, the flow area at the periphery depends on the number of blades and the width of the blade. If the number of blades is fixed, then the flow area depends only on the width of the impeller.

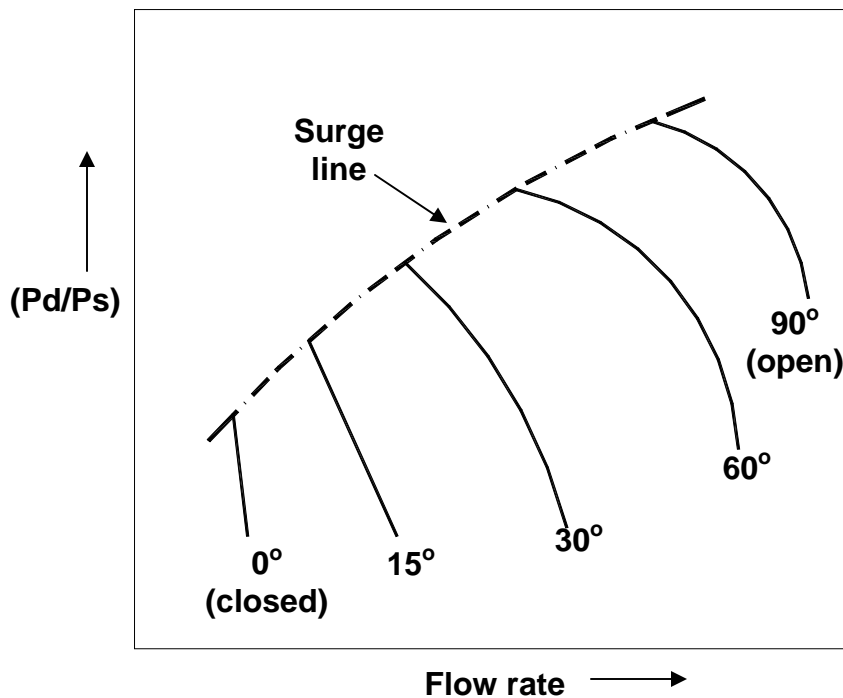
Hence, one way to design the compressors for different refrigerant capacities is by controlling the width of the impeller (Fig.21.5). To design the compressor for smaller refrigerant capacity, one has to reduce the width of the impeller. However, as the width of the impeller is reduced frictional losses between the refrigerant and impeller blades increase leading to lower efficiency. Of course another alternative is to reduce both diameter and width of the impeller simultaneously, thereby the frictional losses can be reduced. However, since this reduces the pressure rise across a single impeller, one has to increase the number of stages, which leads to higher manufacturing costs. This puts a lower limit on the refrigerant capacity of centrifugal compressors. In practice, the lower volumetric flow rate is limited to about  $0.7 \text{ m}^3/\text{s}$  and the minimum refrigeration capacities are around 300 kW for air conditioning applications. Since the compressor works more efficiently at higher volumetric flow rates, refrigerants having lower densities (i.e., higher normal boiling points) such as R 11, water are ideal refrigerants for centrifugal compressors. However, centrifugal compressors in larger capacities are available for a wide range of refrigerants, both synthetic and natural.



**Fig.21.5:** Impeller of a centrifugal compressor with width  $w$

## 21.5. Capacity control:

The capacity of a centrifugal compressor is normally controlled by adjusting inlet guide vanes (pre-rotation vanes). Adjusting the inlet guide vanes provide a swirl at the impeller inlet and thereby introduces a tangential velocity at the inlet to the impeller, which gives rise to different refrigerant flow rates. Figure 21.6 shows the performance of the compressor at different settings of the inlet guide vanes. Use of inlet guide vanes for capacity control is an efficient method as long as the angle of rotation is high, i.e., the vanes are near the fully open condition. When the angle is reduced very much, then this method becomes inefficient as the inlet guide vanes then act as throttling devices.



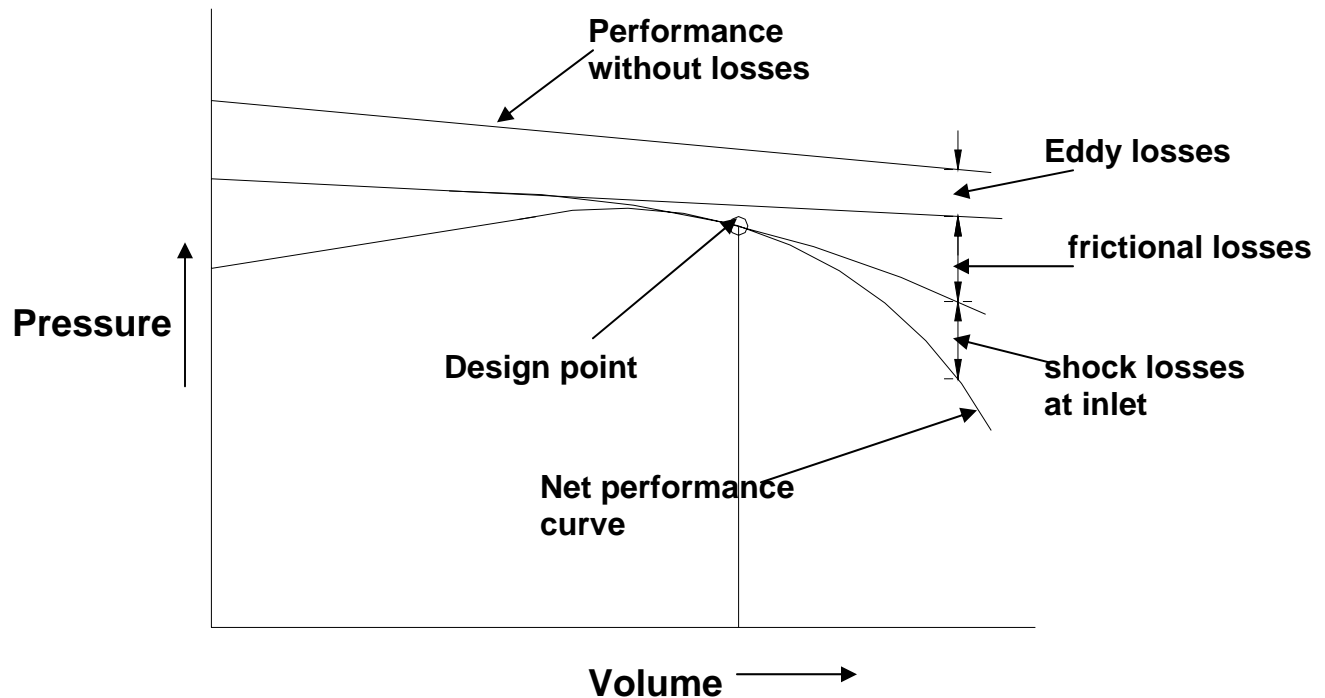
**Fig.21.6:** Effect of angle of pre-rotation vanes on capacity of a centrifugal compressor

In addition to the inlet guide vanes, the capacity control is also possible by adjusting the width of a vaneless diffuser or by adjusting the guide vanes of vaned diffusers. Using a combination of the inlet guide vanes and diffuser, the capacities can be varied from 10 percent to 100 percent of full load capacity.

Capacity can also be controlled by varying the compressor speed using gear drives. For the same pressure rise, operating at lower speeds reduces the flow rate, thereby reducing the refrigeration capacity.

## 21.6. Performance aspects of centrifugal compressor:

Figure 21.7 shows the pressure-volume characteristics of a centrifugal compressor running at certain speed. As shown in the figure, the relation between pressure and volume is a straight line in the absence of any losses. However, in actual compressors losses occur due to eddy formation in the flow passages, frictional losses and shock losses at the inlet to the impeller. As a result the net head developed reduces as shown in the figure. The entry losses are due to change of direction of refrigerant at the inlet and also due to pre-rotation. These losses can be controlled to some extent using the inlet guide vanes. Due to these losses the net performance curve falls below the ideal characteristic curve without losses, and it also shows an optimum point. The optimum point at which the losses are minimum is selected as the design point for the compressor.



**Fig.21.7:** Pressure-volume characteristics of a centrifugal compressor running at certain speed

### Surging:

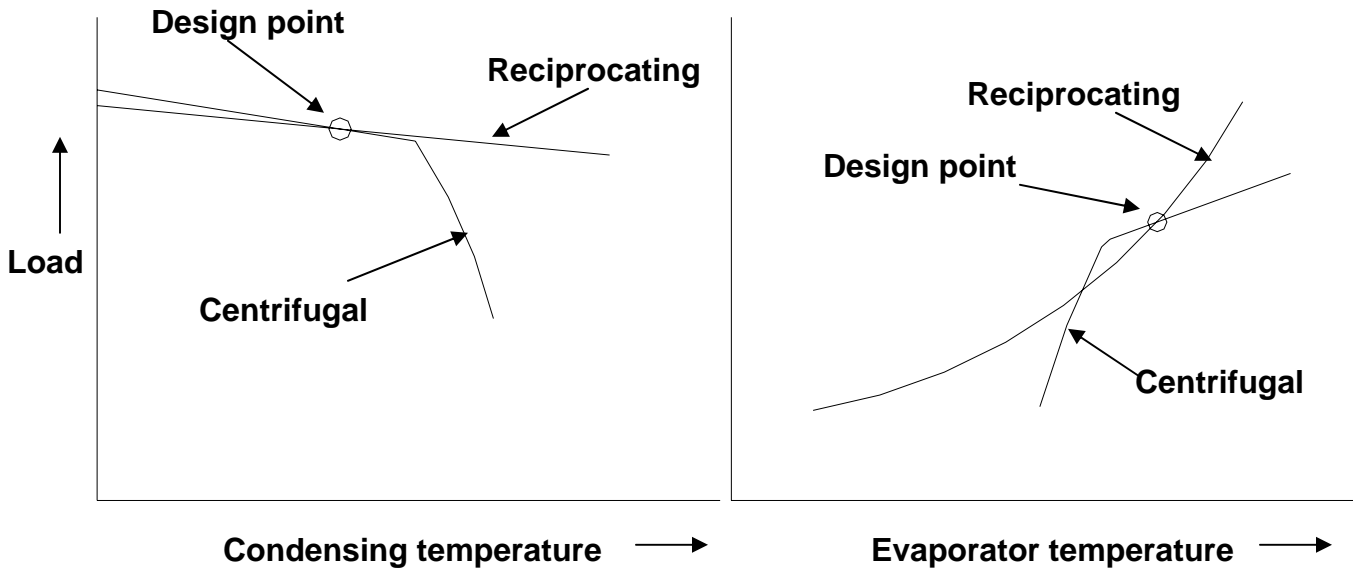
A centrifugal compressor is designed to operate between a given evaporator and condenser pressures. Due to variations either in the heat sink or refrigerated space, the actual evaporator and condenser pressures can be different from their design values. For example, the condenser pressure may

increase if the heat sink temperature increases or the cooling water flow rate reduces. If the resulting pressure difference exceeds the design pressure difference of the compressor, then refrigerant flow reduces and finally stops. Further increase in condenser pressure causes a reverse flow of refrigerant from condenser to evaporator through the compressor. As a result the evaporator pressure increases, the pressure difference reduces and the compressor once again starts pumping the refrigerant in the normal direction. Once the refrigerant starts flowing in the normal direction, the pressure difference increases and again the reversal of flow takes place, as the pressure at the exit of compressor is less than the condenser pressure. This oscillation of refrigerant flow and the resulting rapid variation in pressure difference gives rise to the phenomenon called “*surging*”. Surging produces noise and imposes severe stresses on the bearings of the compressor and motor, ultimately leading to their damage. Hence, continuous surging is highly undesirable, even though it may be tolerated if it occurs occasionally. Surging is most likely to occur when the refrigeration load is low (i.e. evaporator pressure is low) and/or the condensing temperature is high. In some centrifugal compressors, surging is taken care of by bypassing a part of the refrigerant from the discharge side to the evaporator, thereby increasing the load artificially. Thus a centrifugal compressor cannot pump the refrigerant when the condensing pressure exceeds a certain value and/or when the evaporator pressure falls below a certain point. This is unlike reciprocating compressors, which continue to pump refrigerant, albeit at lower flow rates when the condenser temperature increases and/or the evaporator pressure falls.

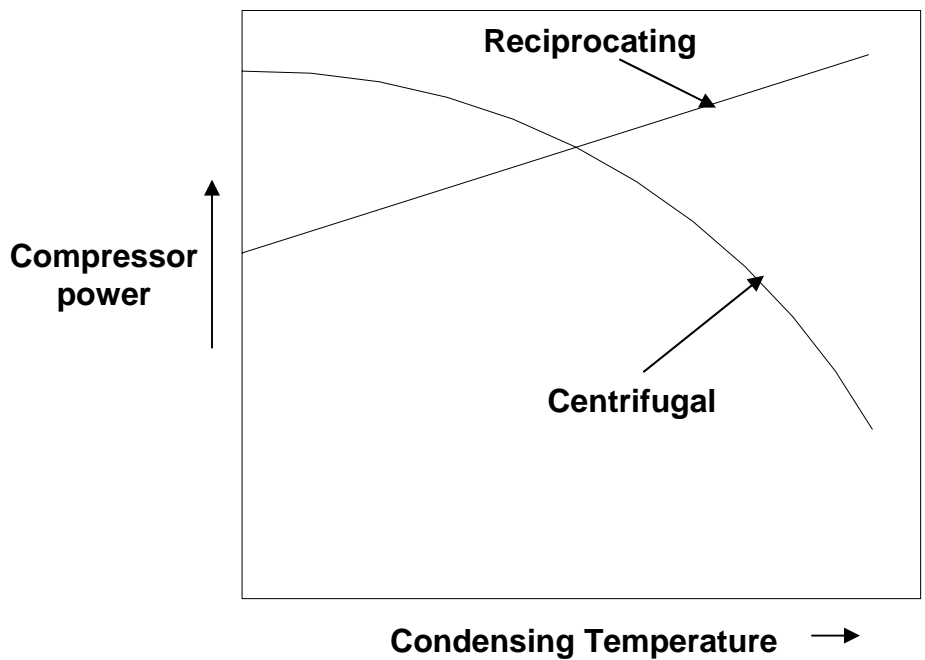
Figures 21.8(a) and (b) show the effect of condensing and evaporating temperatures on the performance of centrifugal compressors and reciprocating compressors. It can be seen from these figures that beyond a certain condenser pressure and below a certain evaporator pressure, the refrigerant capacity of centrifugal compressor decreases rapidly unlike reciprocating compressors where the capacity drop under these conditions is more gradual. However, one advantage with centrifugal compressor is that when operated away from the surge point, the reduction in evaporator temperature with refrigeration load is smaller compared to the reciprocating compressor. This implies that the evaporator temperature of the refrigeration system using a centrifugal compressor remains almost constant over wide variation of refrigeration loads.

Figure 21.9 shows the effect of condensing temperature on power input for both reciprocating as well as centrifugal compressors at a particular evaporator temperature and compressor speed. It can be seen that while the power input increases with condensing temperature for a reciprocating compressor, it decreases with condensing temperature for a centrifugal compressor. This is due to the rapid drop in refrigerant mass flow rate of centrifugal compressor with condensing temperature. This characteristic implies that the problem of compressor overloading at high condensing temperatures does not exist in case of centrifugal compressors.



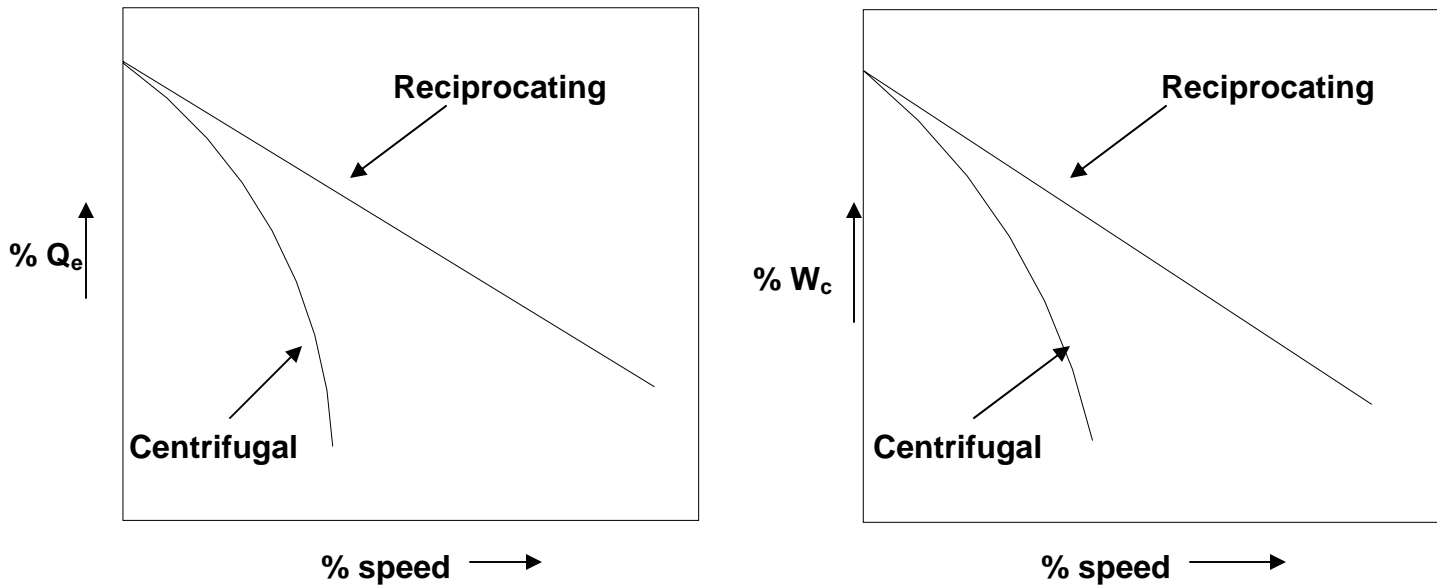


**Fig.21.8(a) and (b):** Effects of condensing and evaporator temperatures on the performance of reciprocating and centrifugal compressors



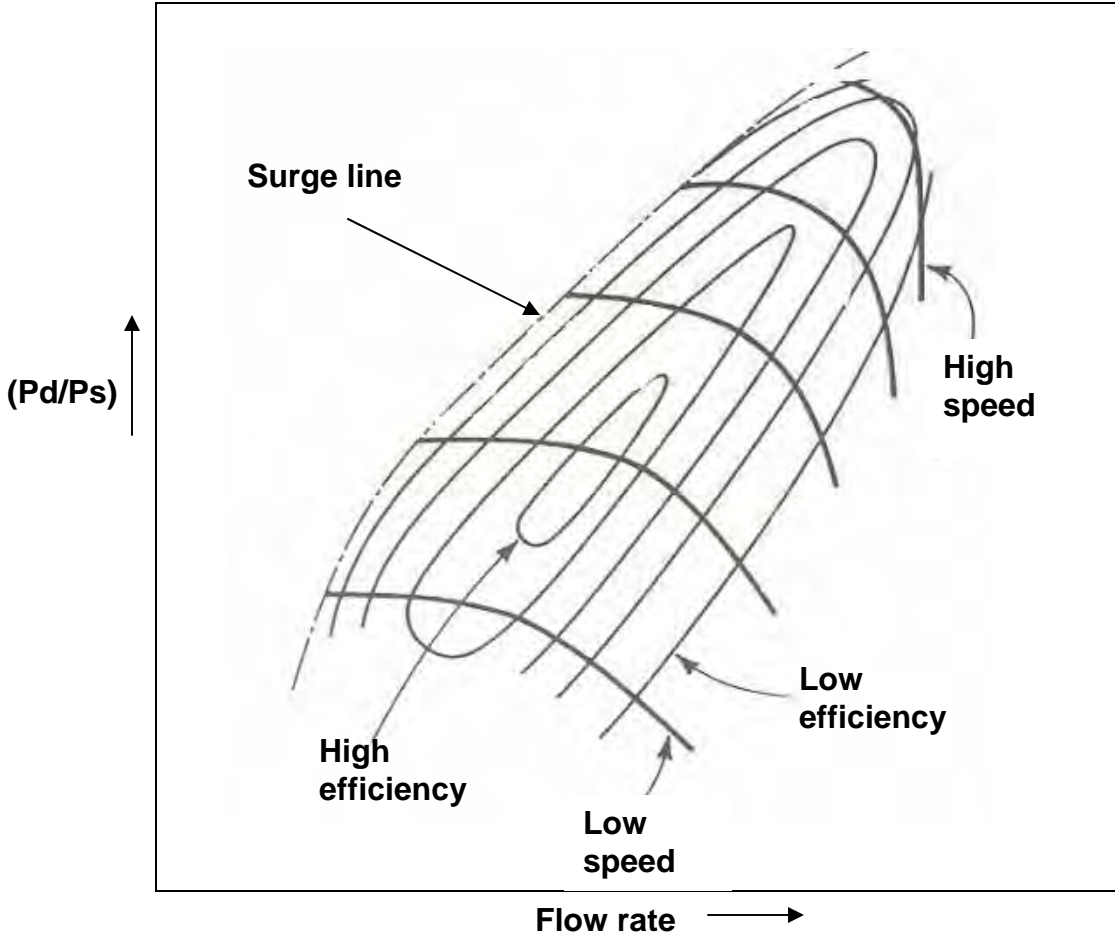
**Fig.21.9:** Effect of condensing temperature on power input for both reciprocating as well as centrifugal compressors at a particular evaporator temperature and compressor speed

Figure 21.10 shows the effect of compressor speed on the performance of reciprocating and centrifugal compressors. It can be seen from the figure that the performance of centrifugal compressor is more sensitive to compressor speed compared to reciprocating compressors.

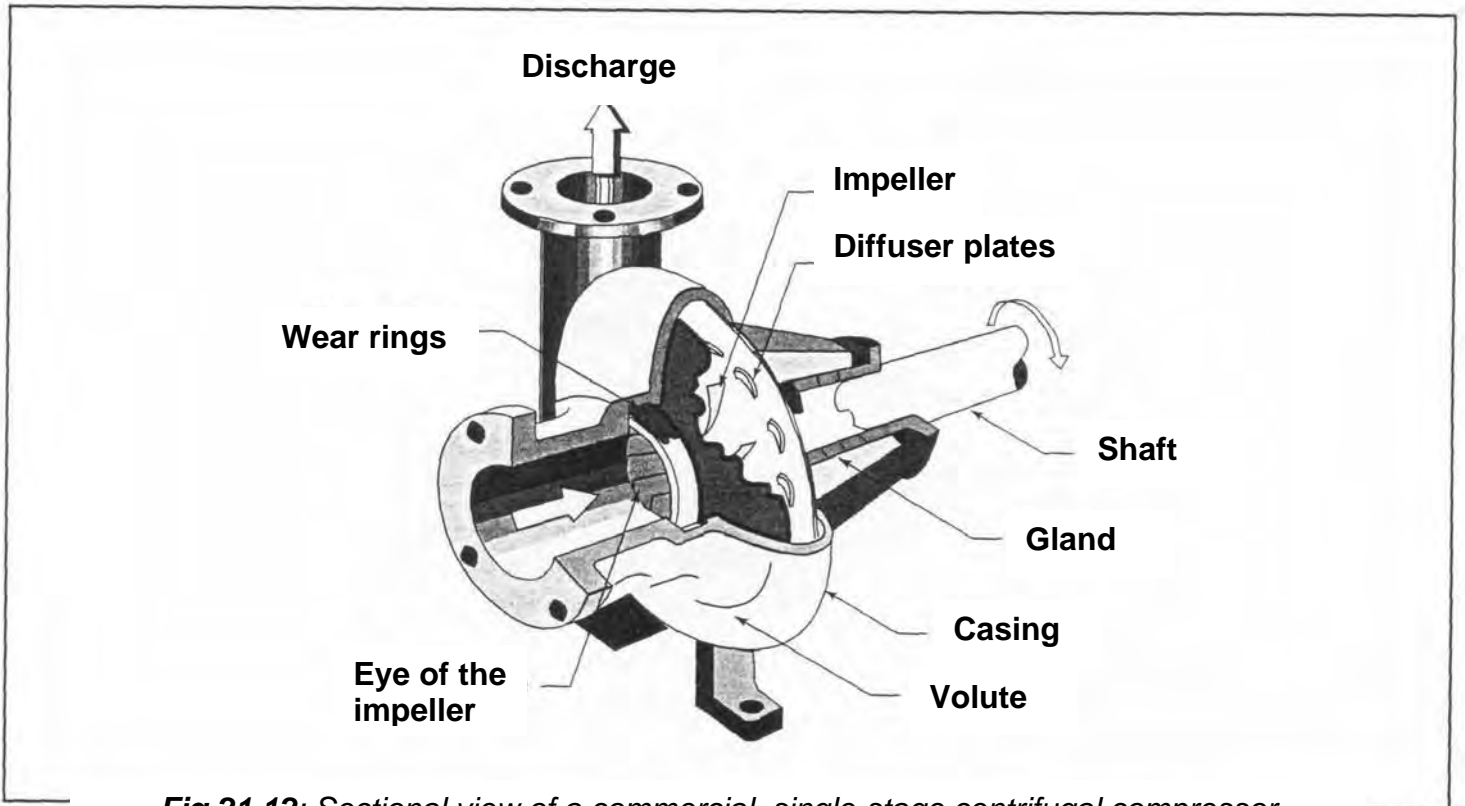


**Fig. 21.10:** Effect of compressor speed on the performance of reciprocating and centrifugal compressors at a given condensing and evaporator temperatures

Figure 21.11 shows the performance characteristics of a centrifugal compressor with backward curved blades. The figure shows the performance at various iso-efficiency values and at different speeds. Such figures are very useful as by using these one can find out, for example the efficiency, flow rate at a given pressure ratio and compressor speed or vice versa. Figure 21.12 shows the sectional view of an actual centrifugal compressor.



**Fig. 21.11:** Performance characteristics of a centrifugal compressor with backward curved blades



**Fig.21.12:** Sectional view of a commercial, single-stage centrifugal compressor

## 21.7: Commercial refrigeration systems with centrifugal compressors:

Commercially centrifugal compressors are available for a wide variety of refrigeration and air conditioning applications with a wide variety of refrigerants. These machines are available for the following ranges:

Evaporator temperatures	:	-100°C to +10°C
Evaporator pressures	:	14 kPa to 700 kPa
Discharge pressure	:	upto 2000 kPa
Rotational speeds	:	1800 to 90,000 RPM
Refrigeration capacity	:	300 kW to 30000 kW

As mentioned before, on the lower side the capacity is limited by the impeller width and tip speeds and on the higher side the capacity is limited by the physical size (currently the maximum impeller diameter is around 2 m).

Since the performance of centrifugal compressor is more sensitive to evaporator and condensing temperatures compared to a reciprocating compressor, it is essential to reduce the pressure drops when a centrifugal compressor is used in commercial systems. Commercial refrigeration systems using centrifugal compressors normally incorporate flash intercoolers to improve the system performance. Since the compressor is normally multi-staged, use of flash intercooler is relatively easy in case of centrifugal compressors.

Centrifugal compressors are normally lubricated using an oil pump (force feed) which can be driven either directly by the compressor rotor or by an external motor. The lubrication system consists of the oil pump, oil reservoir and an oil cooler. The components requiring lubrication are the main bearings, a thrust bearing (for the balancing disc) and the shaft seals. Compared to reciprocating compressors, the lubrication for centrifugal compressors is simplified as very little lubricating oil comes in direct contact with the refrigerant. Normally labyrinth type oil seals are used on the rotor shaft to minimize the leakage of lubricating oil to the refrigerant side. Sometimes oil heaters may be required to avoid excessive dilution of lubricating oil during the plant shutdown.

Commercially both hermetic as well as open type centrifugal compressors are available. Open type compressors are driven by electric motors, internal combustion engines (using a wide variety of fuels) or even steam turbines.

## Questions & answers:

1. Which of the following statements concerning centrifugal compressors are true?

- a) Centrifugal compressors are subjected to less vibration and noise as they rotate at very high speeds
- b) Pressure rise in centrifugal compressor is due to the continuous conversion of angular momentum into static pressure
- c) The stagnation enthalpy of refrigerant vapour remains constant everywhere, except across the impeller blades
- d) Conversion of dynamic pressure into static pressure takes place in the volute casing due to its convergent shape

**Ans.: b) and c)**

2. Which of the following statements concerning centrifugal compressors are true?

- a) Centrifugal compressors with vaneless diffusers are compact compared to vaned diffusers
- b) In multi-stage centrifugal compressors, the width of the blades reduces progressively in the direction of flow
- c) In multi-stage centrifugal compressors, the width of the blades increases progressively in the direction of flow
- d) Multi-staging in centrifugal compressors is commonly used for high refrigerant capacity applications

**Ans.: b)**

3. The polytropic efficiency of a centrifugal compressor is found to be 0.85. The isentropic index of compression of the refrigerant, which behaves as an ideal gas, is 1.17. The polytropic index of compression,  $n$  is then equal to:

- a) 1.206
- b) 0.829
- c) 0.854
- d) 1.141

**Ans.: a)**

4. Which of the following statements are true:

- a) In reciprocating compressors, the irreversibility is mainly due to heat transfer and viscous shear stresses
- b) In reciprocating compressors, the irreversibility is mainly due to heat transfer and pressure drops across valves and connecting pipelines
- c) In centrifugal compressors, the irreversibility is mainly due to heat transfer and viscous shear stresses
- d) In centrifugal compressors, the irreversibility is mainly due to viscous shear stresses

**Ans.: b) and d)**

5. Which of the following statements are true:

- a) Due to slip, the actual pressure rise and volumetric flow rate of a centrifugal compressor is less than that of an ideal compressor
- b) For a given impeller diameter, the slip factor decreases as the number of blades increases
- c) For a given impeller diameter, the slip factor decreases as the number of blades decreases
- d) For a given flow rate, the frictional losses decrease as the number of blades increase

**Ans.: a) and c)**

6. Which of the following statements are true:

- a) The capacity of a centrifugal compressor can be controlled by using inlet guide vanes and by changing the width of the diffuser
- b) Surging in centrifugal compressors takes place as evaporator and condenser pressures increase
- c) Surging in centrifugal compressors takes place as evaporator pressure increases and condenser pressure decreases
- d) Surging in centrifugal compressors takes place as evaporator pressure decreases and condenser pressure increases

**Ans.: a) and d)**

7. Which of the following statements are true:

- a) When operated away from the surge point, the reduction in evaporator temperature with refrigeration load is smaller for centrifugal compressors compared to the reciprocating compressors
- b) When operated away from the surge point, the reduction in evaporator temperature with refrigeration load is much larger compared to the reciprocating compressor
- c) The problem of compressor motor overloading due to high condenser temperature does not take place in a centrifugal compressor
- d) Compared to reciprocating compressor, the performance of centrifugal compressor is less sensitive to speed

**Ans.: a) and c)**

8. Saturated R134a vapour is compressed isentropically from  $-18^{\circ}\text{C}$  ( $P_{\text{sat}}=144.6$  kPa) to a pressure of 433.8 kPa in a single stage centrifugal compressor. Calculate the speed of the compressor at the tip of the impeller assuming that the vapour enters the impeller radially.

**Ans.:**

From the refrigerant property data, the enthalpy and entropy of ammonia vapour at the inlet to the impeller are 387.8 kJ/kg and 1.740 kJ/kg.K, respectively.

At an exit pressure of 433.8 kPa and an entropy of 1.740 kJ/kg.K (isentropic compression), the exit enthalpy of the vapour is found to be 410.4 kJ/kg.

For radial entry, the velocity of ammonia vapour at the tip of the impeller ( $u_2$ ) is given by:

$$u_2^2 = (h_{\text{exit}} - h_{\text{inlet}}) = 410.4 - 387.8 = 22.6 \text{ kJ/kg} = 22600 \text{ J/kg}$$

$$\Rightarrow u_2 = 150.3 \text{ m/s (Ans.)}$$

9. A 2-stage centrifugal compressor operating at 3000 RPM is to compress refrigerant R 134a from an evaporator temperature of  $0^{\circ}\text{C}$  to a condensing temperature of  $32^{\circ}\text{C}$ . If the impeller diameters of both stages have to be same, what is the diameter of the impeller? Assume the suction condition to be dry saturated, compression process to be isentropic, the impeller blades to be radial and refrigerant enters the impeller axially.

Given:

Refrigerant	= R 134a
Evaporator temperature	= 0°C
Condensing temperature	= 32°C
Inlet condition	= Dry saturated
Compression process	= Isentropic (reversible, adiabatic)
Number of stages	= 2
Rotational speed	= 3000 RPM
Impeller blades	= Radial
Tangential velocity at inlet	= 0 m/s
Diameter of impeller	= Same for both stages

**Ans.:**

From refrigerant property data:

Enthalpy of refrigerant at compressor inlet, $h_i$	= 398.6 kJ/kg
Enthalpy of refrigerant at compressor exit, $h_e$	= 419.8 kJ/kg

Since the blades are radial with no tangential velocity component at inlet, the enthalpy rise across each stage,

$$\Delta h_1 = \Delta h_2 = u_2^2 = \Delta h_{\text{stage}}$$

⇒ enthalpy rise across the compressor,  $(h_e - h_i) = \Delta h_1 + \Delta h_2 = 2\Delta h_{\text{stage}}$

$$\Rightarrow \Delta h_{\text{stage}} = (h_e - h_i)/2 = (419.8 - 398.6)/2 = 10.6 \text{ kJ/kg}$$

$$\therefore u_2 = (\Delta h_{\text{stage}})^{1/2} = (10.6 \times 1000)^{1/2} = 103 \text{ m/s}$$

$$u_2 = \omega \cdot r_2$$

$$\omega = 2\pi \times 3000/60 = 100\pi \text{ rad/s}$$

$$\therefore r_2 = \therefore u_2/\omega = 0.3279 \text{ m} \Rightarrow \text{impeller diameter} = 2r_2 = 0.6558 \text{ m (Ans.)}$$

10. A backward curved centrifugal compressor is to compress refrigerant R134a. The diameter of the impeller is 0.6 m and the blade angle is 60°. The peripheral area is 0.002 m<sup>2</sup> and the flow coefficient (ratio of normal component of velocity to tip speed) is 0.5. If the pressure and temperature of refrigerant at the exit of the impeller are found to be 7.702 bar and 40°C, find the specific work and power input to the compressor. The impeller rotates at 9000 RPM. The tangential component of velocity at the inlet to the impeller may be assumed to be negligible.



Ans.: Given:

Refrigerant	:	R134a
Diameter of impeller	=	0.6 m
Blade angle, $\beta$	=	$60^\circ$
Peripheral flow area, $A_{f,p}$	=	$0.002 \text{ m}^2$
Flow coefficient ( $V_{n,2}/u_2$ )	=	0.5
Impeller speed	=	9000 RPM
Exit pressure	=	7.702 bar
Exit temperature	=	$40^\circ\text{C}$

To find: Specific work input ( $w$ ) and power input ( $W$ )

When the tangential component of velocity at the impeller inlet is negligible and the slip factor is unity, then the power input to the compressor is given by:

$$W = m u_2 V_{t,2} = m u_2^2 \left( 1 - \frac{V_{n,2} \cot \beta}{u_2} \right)$$

The tip speed,  $u_2$  is obtained from the RPM ( $N$ ) and the impeller diameter ( $d$ ) as:

$$u_2 = 2\pi(N/60)(d/2) = 2\pi(9000/60)(0.6/2) = 282.74 \text{ m/s}$$

Since the flow coefficient is given as 0.5, the normal component of velocity at the exit of the impeller,  $V_{n,2}$  is given by:

$$V_{n,2} = 0.5u_2 = 141.37 \text{ m/s}$$

The mass flow rate of refrigerant is obtained from the normal component at the tip ( $V_{n,2}$ ), peripheral area ( $A_{f,p}$ ) and the specific volume of refrigerant at the exit ( $v_2$ ; obtained from exit pressure and temperature) as:

$$m = \frac{V_{n,2} A_{f,p}}{v_2} = \frac{141.37 \times 0.002}{0.1846} = 1.532 \text{ kg/s}$$

Substituting the values of mass flow rate, tip velocity, normal component of velocity at the impeller exit and the blade angle in the expression for power input, we obtain:

$$\text{Power input to the compressor, } W = 87117 \text{ W} = 87.117 \text{ kW}$$

(Ans.)

$$\text{Specific work} = W/m = 56.865 \text{ kJ/kg}$$

# Lesson

## 22

# Condensers & Evaporators

## The specific objectives of this lesson are to:

1. Discuss general aspects of evaporators and condensers used in refrigeration systems (*Section 22.1*)
2. Introduce refrigerant condensers (*Section 22.2*)
3. Classify refrigerant condensers based on the external fluid used, based on constructional details etc. (*Section 22.3*)
4. Compare air cooled condensers with water cooled condensers (*Section 22.3.4*)
5. Present analysis and design aspects of refrigerant condensers, estimation of heat transfer coefficients on external fluid side on refrigerant side for different configurations (*Section 22.4*)
6. Discuss briefly the effect of presence of air and other non-condensable gases in refrigerant condensers (*Section 22.5*)
7. Discuss briefly the concept of optimum condensing pressure for lowest running cost of a refrigeration system (*Section 22.6*)

At the end of the lecture, the student should be able to:

1. Classify and describe refrigerant condensers based on the external fluid used, based on the external fluid flow and based on constructional aspects
2. Compare air-cooled condensers with water-cooled condensers
3. Perform condenser design calculations using various correlations presented for estimating heat transfer coefficients on external fluid and refrigerant side and estimate the required condenser area for a given refrigeration system
4. Explain the effect of presence of non-condensable gases on condenser performance
5. Explain the concept of optimum condenser pressure

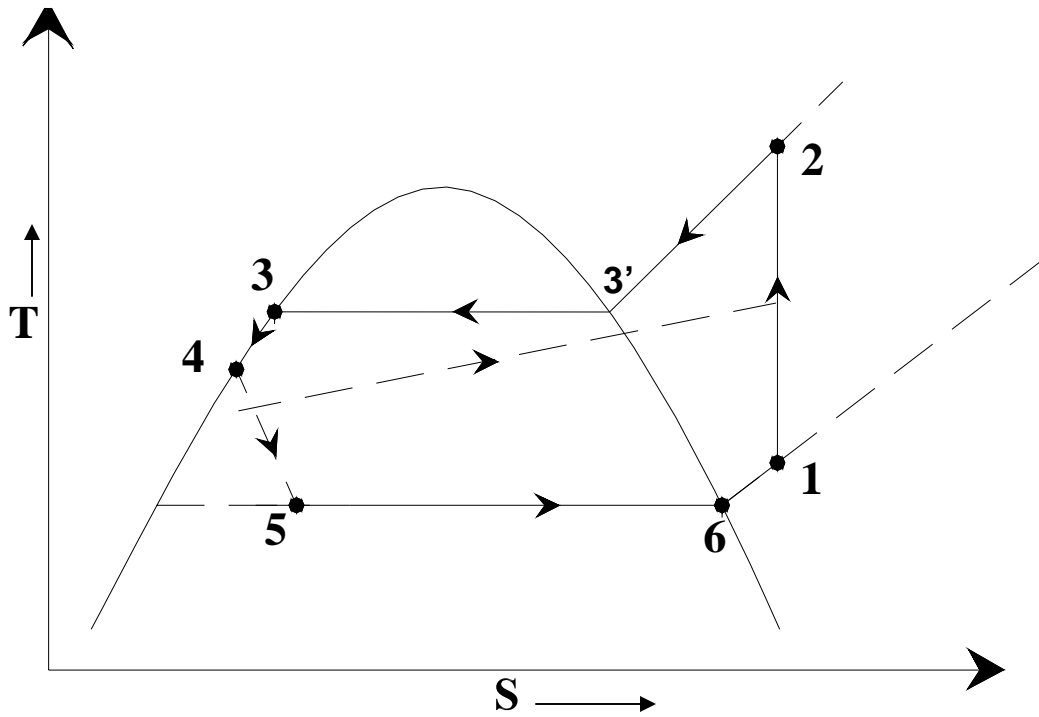
### 22.1. Introduction:

Condensers and evaporators are basically heat exchangers in which the refrigerant undergoes a phase change. Next to compressors, proper design and selection of condensers and evaporators is very important for satisfactory performance of any refrigeration system. Since both condensers and evaporators are essentially heat exchangers, they have many things in common as far as the design of these components is concerned. However, differences exist as far as the heat transfer phenomena is concerned. In condensers the refrigerant vapour condenses by rejecting heat to an external fluid, which acts as a heat sink. Normally, the external fluid does not undergo any phase change, except in some special cases such as in cascade condensers, where the external fluid (another refrigerant) evaporates. In evaporators, the liquid refrigerant evaporates by extracting heat from an external fluid (low temperature heat source). The external fluid may not undergo phase change, for example if the system is used for sensibly cooling water, air or some other fluid. There are many refrigeration and

air conditioning applications, where the external fluid also undergoes phase change. For example, in a typical summer air conditioning system, the moist air is dehumidified by condensing water vapour and then, removing the condensed liquid water. In many low temperature refrigeration applications freezing or frosting of evaporators takes place. These aspects have to be considered while designing condensers and evaporators.

## 22.2. Condensers:

As already mentioned, condenser is an important component of any refrigeration system. In a typical refrigerant condenser, the refrigerant enters the condenser in a superheated state. It is first de-superheated and then condensed by rejecting heat to an external medium. The refrigerant may leave the condenser as a saturated or a sub-cooled liquid, depending upon the temperature of the external medium and design of the condenser. Figure 22.1 shows the variation of refrigeration cycle on T-s diagram. In the figure, the heat rejection process is represented by 2-3'-3-4. The temperature profile of the external fluid, which is assumed to undergo only sensible heat transfer, is shown by dashed line. It can be seen that process 2-3' is a de-superheating process, during which the refrigerant is cooled sensibly from a temperature  $T_2$  to the saturation temperature corresponding condensing pressure,  $T_3$ . Process 3'-3 is the condensation process, during which the temperature of the refrigerant remains constant as it undergoes a phase change process. In actual refrigeration systems with a finite pressure drop in the condenser or in a system using a zeotropic refrigerant mixture, the temperature of the refrigerant changes during the condensation process also. However, at present for simplicity, it is assumed that the refrigerant used is a pure refrigerant (or an azeotropic mixture) and the condenser pressure remains constant during the condensation process. Process 3-4 is a sensible, sub cooling process, during which the refrigerant temperature drops from  $T_3$  to  $T_4$ .



**Fig.22.1:** Refrigeration cycle on T-s diagram

### 22.3. Classification of condensers:

Based on the external fluid, condensers can be classified as:

- a) Air cooled condensers
- b) Water cooled condensers, and
- c) Evaporative condensers

#### 22.3.1. Air-cooled condensers:

As the name implies, in air-cooled condensers air is the external fluid, i.e., the refrigerant rejects heat to air flowing over the condenser. Air-cooled condensers can be further classified into natural convection type or forced convection type.

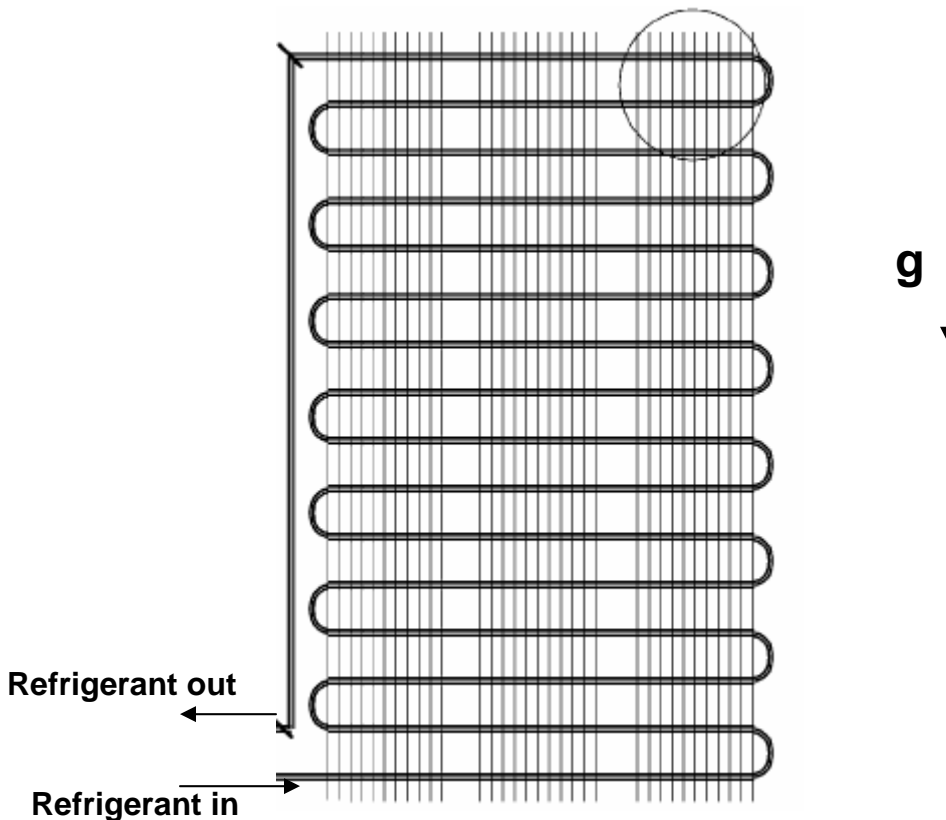
##### Natural convection type:

In natural convection type, heat transfer from the condenser is by buoyancy induced natural convection and radiation. Since the flow rate of air is small and the radiation heat transfer is also not very high, the combined heat transfer coefficient in these condensers is small. As a result a relatively large condensing surface is required to reject a given amount of heat. Hence these condensers are used for small capacity refrigeration systems like household refrigerators and freezers. The natural convection type condensers are either plate surface type or finned tube type. In plate surface type condensers used in small refrigerators and freezers, the refrigerant carrying tubes are attached to the outer walls of the refrigerator. The whole body of the refrigerator (except the

door) acts like a fin. Insulation is provided between the outer cover that acts like fin and the inner plastic cover of the refrigerator. It is for this reason that outer body of the refrigerator is always warm. Since the surface is warm, the problem of moisture condensation on the walls of the refrigerator does not arise in these systems. These condensers are sometimes called as flat back condensers.

The finned type condensers are mounted either below the refrigerator at an angle or on the backside of the refrigerator. In case, it is mounted below, then the warm air rises up and to assist it an air envelope is formed by providing a jacket on backside of the refrigerator. The fin spacing is kept large to minimize the effect of fouling by dust and to allow air to flow freely with little resistance.

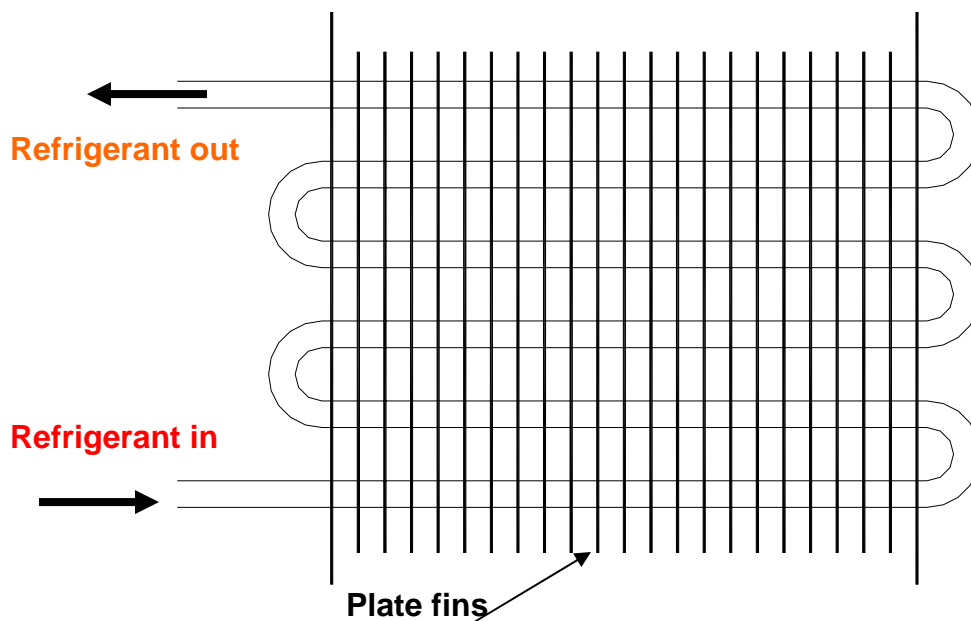
In the older designs, the condenser tube (in serpentine form) was attached to a plate and the plate was mounted on the backside of the refrigerator. The plate acted like a fin and warm air rose up along it. In another common design, thin wires are welded to the serpentine tube coil. The wires act like fins for increased heat transfer area. Figure 22.2 shows the schematic of a wire-and-tube type condenser commonly used in domestic refrigerators. Regardless of the type, refrigerators employing natural convection condenser should be located in such a way that air can flow freely over the condenser surface.



**Fig.22.2:** Schematic of a wire-and-tube type condenser used in small refrigeration systems

### Forced convection type:

In forced convection type condensers, the circulation of air over the condenser surface is maintained by using a fan or a blower. These condensers normally use fins on air-side for good heat transfer. The fins can be either plate type or annular type. Figure 22.3 shows the schematic of a plate-fin type condenser. Forced convection type condensers are commonly used in window air conditioners, water coolers and packaged air conditioning plants. These are either chassis mounted or remote mounted. In chassis mounted type, the compressor, induction motor, condenser with condenser fan, accumulator, HP/LP cut- out switch and pressure gauges are mounted on a single chassis. It is called condensing unit of rated capacity. The components are matched to condense the required mass flow rate of refrigerant to meet the rated cooling capacity. The remote mounted type, is either vertical or roof mounted horizontal type. Typically the air velocity varies between 2 m/s to 3.5 m/s for economic design with airflow rates of 12 to 20 cmm per ton of refrigeration (TR). The air specific heat is 1.005 kJ/kg-K and density is 1.2 kg/m<sup>3</sup>. Therefore for 1 TR the temperature rise  $\Delta t_a = 3.5167 / (1.2 \times 1.005 \times 16 / 60) = 10.9^\circ\text{C}$  for average air flow rate of 16 cmm. Hence, the air temperature rises by 10 to 15°C as compared to 3 to 6°C for water in water cooled condensers.



**Fig.22.3:** Forced convection, plate fin-and-tube type condenser

The area of the condenser seen from outside in the airflow direction is called face area. The velocity at the face is called face velocity. This is given by the volume flow rate divided by the face area. The face velocity is usually around 2m/s to 3.5 m/s to limit the pressure drop due to frictional resistance. The coils of the tube in the flow direction are called rows. A condenser may have two to eight

rows of the tubes carrying the refrigerant. The moist air flows over the fins while the refrigerant flows inside the tubes. The fins are usually of aluminum and tubes are made of copper. Holes of diameter slightly less than the tube diameter are punched in the plates and plates are slid over the tube bank. Then the copper tubes are pressurized which expands the tubes and makes a good thermal contact between the tube and fins. This process is also known as bulleting. For ammonia condensers mild steel tubes with mild steel fins are used. In this case the fins are either welded or galvanizing is done to make a good thermal contact between fin and tube. In case of ammonia, annular crimped spiral fins are also used over individual tubes instead of flat-plate fins. In finned tube heat exchangers the fin spacing may vary from 3 to 7 fins per cm. The secondary surface area is 10 to 30 times the bare pipe area hence; the finned coils are very compact and have smaller weight.

### **22.3.2. Water Cooled Condensers:**

In water cooled condensers water is the external fluid. Depending upon the construction, water cooled condensers can be further classified into:

1. Double pipe or tube-in-tube type
2. Shell-and-coil type
3. Shell-and-tube type

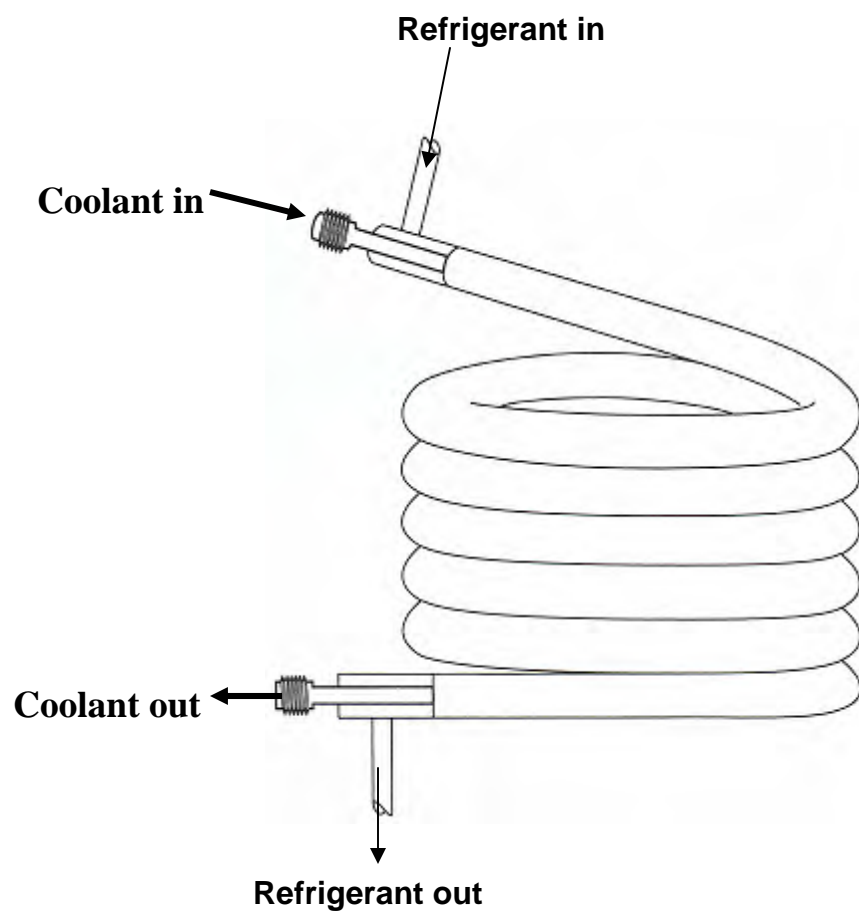
#### **Double Pipe or tube-in-tube type:**

Double pipe condensers are normally used up to 10 TR capacity. Figure 22.4 shows the schematic of a double pipe type condenser. As shown in the figure, in these condensers the cold water flows through the inner tube, while the refrigerant flows through the annulus in counter flow. Headers are used at both the ends to make the length of the condenser small and reduce pressure drop. The refrigerant in the annulus rejects a part of its heat to the surroundings by free convection and radiation. The heat transfer coefficient is usually low because of poor liquid refrigerant drainage if the tubes are long.

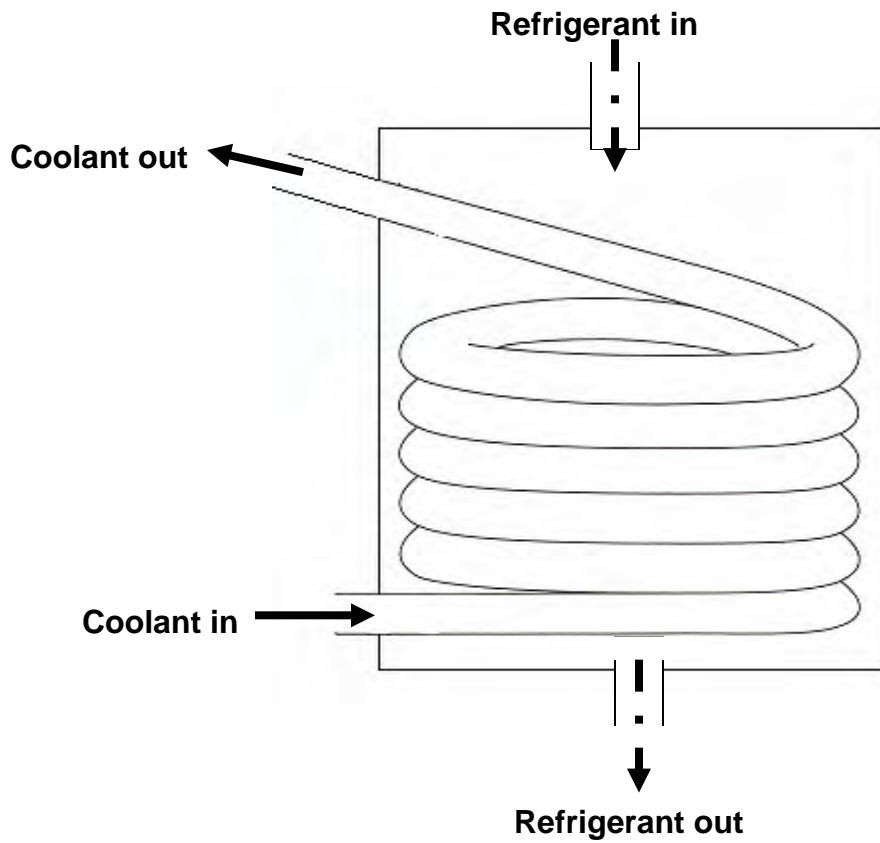
#### **Shell-and-coil type:**

These condensers are used in systems up to 50 TR capacity. The water flows through multiple coils, which may have fins to increase the heat transfer coefficient. The refrigerant flows through the shell. In smaller capacity condensers, refrigerant flows through coils while water flows through the shell. Figure 22.5 shows a shell-and-coil type condenser. When water flows through the coils, cleaning is done by circulating suitable chemicals through the coils.





**Fig.22.4:** Double pipe (tube-in-tube) type condenser

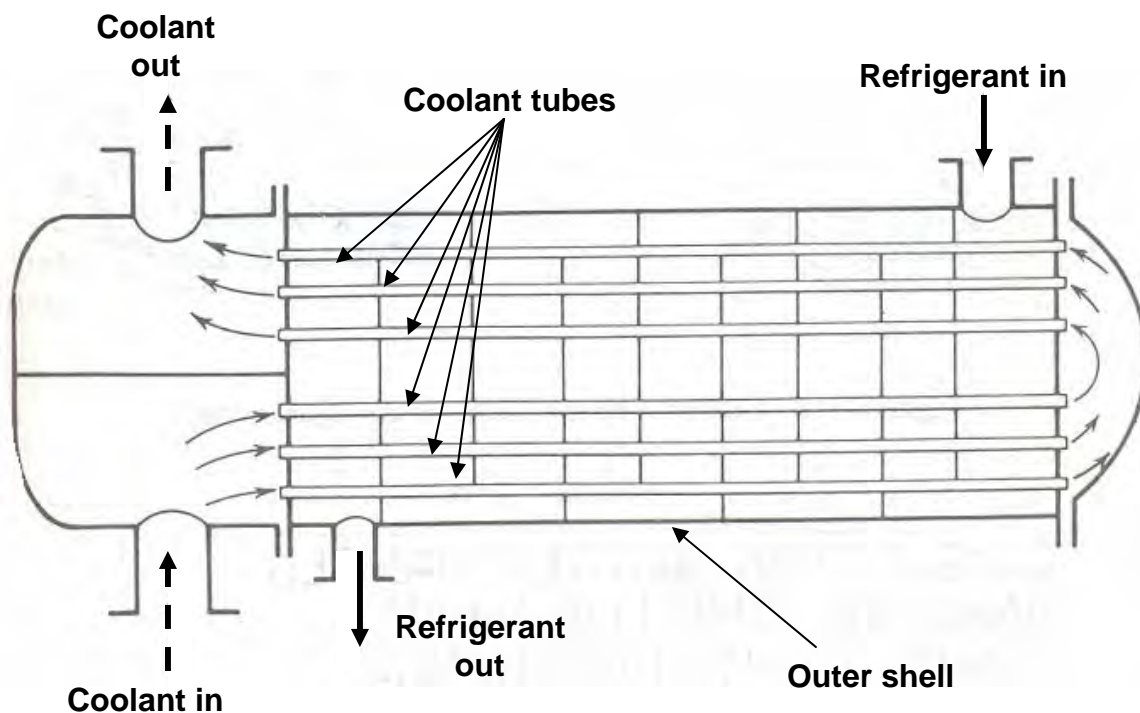


**Fig.22.5:** Shell-and-coil type condenser

### Shell-and-tube type:

This is the most common type of condenser used in systems from 2 TR upto thousands of TR capacity. In these condensers the refrigerant flows through the shell while water flows through the tubes in single to four passes. The condensed refrigerant collects at the bottom of the shell. The coldest water contacts the liquid refrigerant so that some subcooling can also be obtained. The liquid refrigerant is drained from the bottom to the receiver. There might be a vent connecting the receiver to the condenser for smooth drainage of liquid refrigerant. The shell also acts as a receiver. Further the refrigerant also rejects heat to the surroundings from the shell. The most common type is horizontal shell type. A schematic diagram of horizontal shell-and-tube type condenser is shown in Fig. 22.6.

Vertical shell-and-tube type condensers are usually used with ammonia in large capacity systems so that cleaning of the tubes is possible from top while the plant is running.

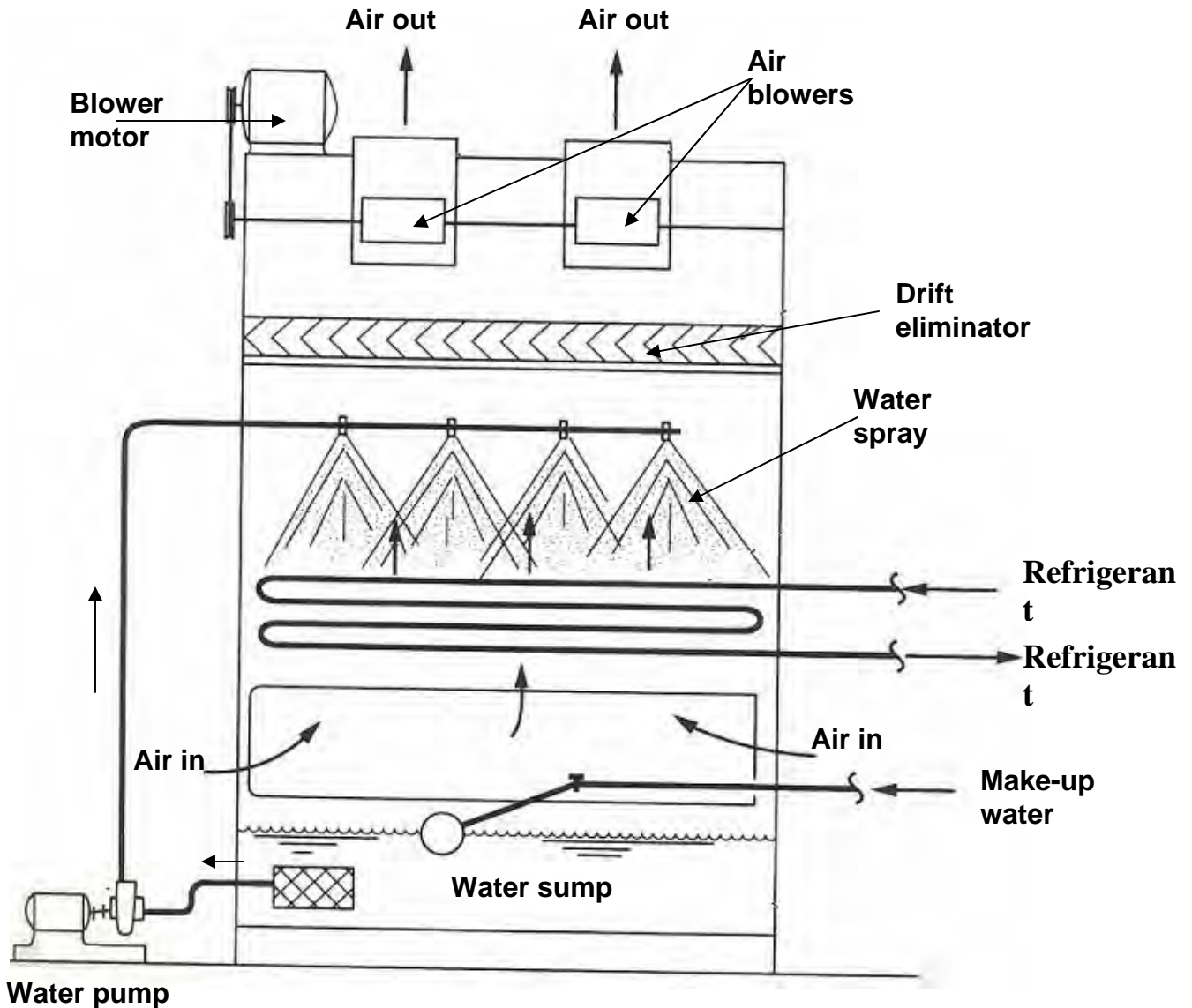


**Fig.22.6:** A two-pass, shell-and-tube type condenser

### 22.3.3. Evaporative condensers:

In evaporative condensers, both air and water are used to extract heat from the condensing refrigerant. Figure 22.7 shows the schematic of an evaporative condenser. Evaporative condensers combine the features of a cooling tower and water-cooled condenser in a single unit. In these condensers,

the water is sprayed from top part on a bank of tubes carrying the refrigerant and air is induced upwards. There is a thin water film around the condenser tubes from which evaporative cooling takes place. The heat transfer coefficient for evaporative cooling is very large. Hence, the refrigeration system can be operated at low condensing temperatures (about 11 to 13 K above the wet bulb temperature of air). The water spray countercurrent to the airflow acts as cooling tower. The role of air is primarily to increase the rate of evaporation of water. The required air flow rates are in the range of 350 to 500 m<sup>3</sup>/h per TR of refrigeration capacity.



*Fig.22.7: Schematic of an evaporative condenser*

Evaporative condensers are used in medium to large capacity systems. These are normally cheaper compared to water cooled condensers, which require a separate cooling tower. Evaporative condensers are used in places where water is scarce. Since water is used in a closed loop, only a small part of the water evaporates. Make-up water is supplied to take care of the evaporative loss. The water consumption is typically very low, about 5 percent of an equivalent water cooled condenser with a cooling tower. However, since condenser has to be kept outside, this type of condenser requires a longer length of refrigerant tubing, which calls for larger refrigerant inventory and higher pressure drops. Since the condenser is kept outside, to prevent the water from freezing, when outside temperatures are very low, a heater is placed in the water tank. When outside temperatures are very low it is possible to switch-off the water pump and run only the blowers, so that the condenser acts as an air cooled condenser.

Another simple form of condenser used normally in older type cold storages is called as atmospheric condenser. The principle of the atmospheric condenser is similar to evaporative condenser, with a difference that the air flow over the condenser takes place by natural means as no fans or blowers are used. A spray system sprays water over condenser tubes. Heat transfer outside the tubes takes by both sensible cooling and evaporation, as a result the external heat transfer coefficient is relatively large. The condenser pipes are normally large, and they can be either horizontal or vertical. Though these condensers are effective and economical they are being replaced with other types of condensers due to the problems such as algae formation on condenser tubes, uncertainty due to external air circulation etc.

#### 22.3.4. Air cooled vs water cooled condensers:

The Salient features of air cooled and water cooled condensers are shown below in Table 22.1. The advantages and disadvantages of each type are discussed below.

Parameter	Air cooled	Water cooled
Temperature difference, $T_C - T_{coolant}$	6 to 22° C	6 to 12° C
Volume flow rate of coolant per TR	12 to 20 m <sup>3</sup> /min	0.007 to 0.02 m <sup>3</sup> /min
Heat transfer area per TR	10 to 15 m <sup>2</sup>	0.5 to 1.0 m <sup>2</sup>
Face Velocity	2.5 to 6 m/s	2 to 3 m/s
Fan or pump power per TR	75 to 100 W	negligible

Table 22.1: Comparison between air cooled and water cooled condensers

#### Advantages and disadvantages:

Air-cooled condensers are simple in construction since no pipes are required for air. Further, the disposal of warm air is not a problem and it is

available in plenty. The fouling of condenser is small and maintenance cost is low. However, since the specific heat of air is one fourth of that of water and density is one thousandth of that of water, volume flow rates required are very large. The thermal conductivity is small; hence heat transfer coefficient is also very small. Also, air is available at dry-bulb temperature while water is available at a lower temperature, which is 2 to 3 °C above the wet-bulb temperature. The temperature rise of air is much larger than that of water, therefore the condenser temperature becomes large and COP reduces. Its use is normally restricted to 10 TR although blower power goes up beyond 5 TR. In systems up to 3 TR with open compressors it is mounted on the same chassis as the compressor and the compressor motor drives the condenser fan also. In middle-east countries where is shortage of fresh water these are used up to 100 TR or more.

The air-cooled condensers cost two to three times more than water-cooled condensers. The water-cooled condenser requires cooling tower since water is scarce in municipality areas and has to be recycled. Water from lakes and rivers cannot be thrown back in warm state since it affects the marine life adversely. Increased first cost and maintenance cost of cooling tower offsets the cost advantage of water-cooled condenser. Fouling of heat exchange surface is a big problem in use of water.

## 22.4. Analysis of condensers:

From Fig.22.1, the total heat rejected in the condenser,  $Q_c$  is given by:

$$Q_c = \dot{m}(h_2 - h_4) = \dot{m}_{ext} C_{p,ext} (T_{ext,o} - T_{ext,i}) \quad (22.1)$$

where  $\dot{m}$  is the mass flow rate of refrigerant

$h_2, h_4$  are the inlet and exit enthalpies of refrigerant

$\dot{m}_{ext}$  is the mass flow rate of the external fluid

$C_{p,ext}$  is an average specific heat of the external fluid, and

$T_{ext,i}$  and  $T_{ext,o}$  are the inlet and exit temperatures of the external fluid

The required condenser area is then given by the equation:

$$Q_c = U.A.\Delta T_m \quad (22.2)$$

where  $U$  is the overall heat transfer coefficient

$A$  is the heat transfer area of the condenser, and

$\Delta T_m$  is mean temperature difference between refrigerant and external fluid

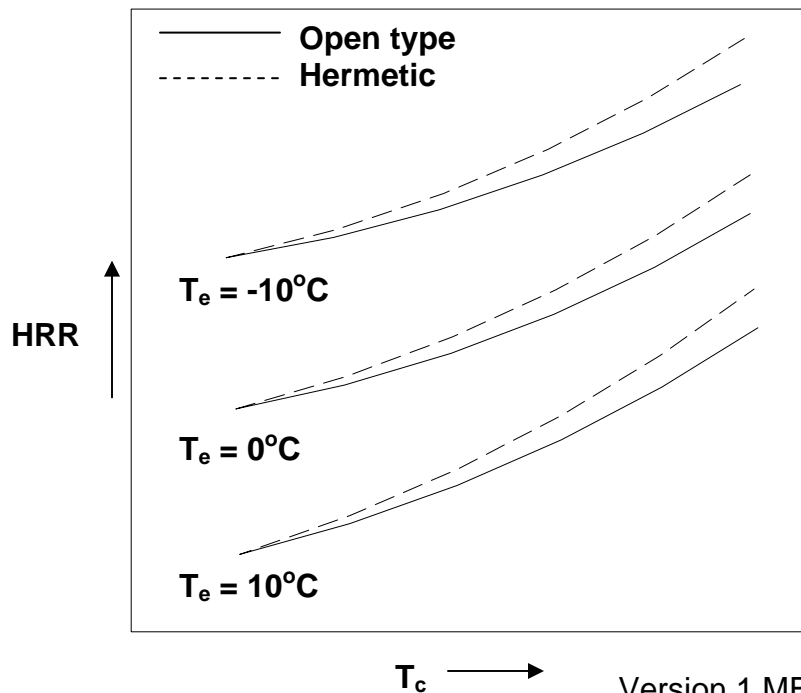
In a typical design problem, the final objective is to find the heat transfer area  $A$  required from given input. From the above equation it can be seen that to find heat transfer area, one should know the amount of heat transfer rate across the condenser ( $Q_c$ ), the overall heat transfer coefficient ( $U$ ) and the mean temperature difference. The heat transfer rate in the condenser depends on the refrigeration capacity of the system and system COP. The overall heat transfer coefficient depends on the type and design of condenser. The mean temperature difference depends on the operating temperature of the refrigeration system, type of the condenser and the external fluid. In a typical rating problem, the objective is to find the rate of heat transfer when other parameters are fixed.

### 22.4.1. Condenser Heat Rejection Ratio (HRR):

The heat rejection ratio (HRR) is the ratio of heat rejected to the heat absorbed (refrigeration capacity), that is,

$$\text{HRR} = \frac{Q_c}{Q_e} = \frac{Q_e + W_c}{Q_e} = 1 + \frac{1}{\text{COP}} \quad (22.3)$$

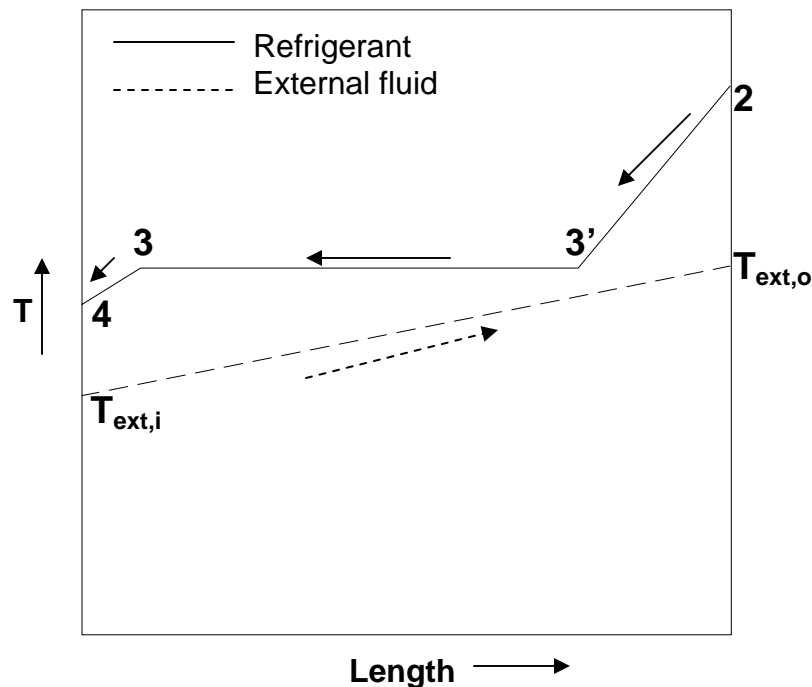
For a fixed condenser temperature, as the evaporator temperature decreases the COP decreases and heat rejection ratio increases. For fixed evaporator temperature as the condenser temperature increases the COP decreases hence the heat rejection ratio increases. At a given evaporator and condenser temperatures, the HRR of refrigeration systems using hermetic compressors is higher than that of open compressor systems. As discussed in earlier chapters, this is due to the additional heat rejected by motor and compressor in hermetic systems. These characteristics are shown in Fig.22.8. Such curves can be drawn for all refrigerants so that the condenser heat rejection can be determined for given  $T_e$ ,  $T_c$  and TR.



**Fig.22.8:** Variation of heat rejection ratio (HRR) with evaporator and condenser temperatures

### 22.4.2. Mean temperature difference:

In a refrigerant condenser, the mean temperature difference  $\Delta T_m$ , between the refrigerant and the external fluid varies continuously along the length as shown in Fig.22.9. However, the heat transfer coefficient on the refrigerant side,  $h_r$  is small during de-superheating (2-3) in vapour phase but temperature difference between refrigerant and coolant  $\Delta T$  is large, while during condensation (3-3') the heat transfer coefficient on refrigerant side is large and the temperature difference is small. As a result, the product  $h_r \Delta T$  is approximately same in both the regions; hence as an approximation one may design the condenser by assuming that condensation occurs throughout the condenser. This implies that the refrigerant temperature is assumed to remain constant at condensing temperature throughout the length of the condenser. As mentioned, this is an approximation, and is considered to be adequate for rough estimation of condenser area. However, for accurate design of condenser, one has to consider the de-superheating, condensation and subcooling regions separately and evaluate the area required for each region, and finally find the total area.



**Fig.22.9:** Variation of refrigerant and external fluid temperature in a condenser

If we assume condensation throughout the length of the condenser and also assume the pressure drop to be negligible, then the mean temperature difference is given by the Log Mean Temperature Difference (LMTD):

$$\text{LMTD} = \frac{(T_{\text{ext,o}} - T_{\text{ext,i}})}{\ln\left(\frac{T_c - T_{\text{ext,i}}}{T_c - T_{\text{ext,o}}}\right)} \quad (22.4)$$

In the above equation,  $T_{\text{ext,i}}$  and  $T_{\text{ext,o}}$  are the inlet and outlet temperatures of the external fluid, and  $T_c$  is the condensing temperature.

### 22.4.3. Overall heat transfer coefficient:

Evaluation of overall heat transfer coefficient,  $U$  is an important step in the design of a condenser. The overall heat transfer coefficient can be based on either internal area ( $A_i$ ) or external area ( $A_o$ ) of the condenser. In general we can write:

$$UA = U_i A_i = U_o A_o = \frac{1}{\sum_{i=1}^n R_i} \quad (22.5)$$

where  $R_i$  is the heat transfer resistance of  $i^{\text{th}}$  component

A general expression for overall heat transfer coefficient is given by:

$$\frac{1}{U_i A_i} = \frac{1}{U_o A_o} = \frac{1}{[h(A_f \eta_f + A_b)]_o} + \frac{\Delta x}{k_w A_m} + \frac{1}{[h(A_f \eta_f + A_b)]_i} + \frac{R''_{f,o}}{A_o} + \frac{R''_{f,i}}{A_i} \quad (22.6)$$

In the above expression,  $h$  is the convective heat transfer coefficient,  $A_f$  and  $A_b$  are the finned and bare tube areas of the heat exchanger, respectively,  $\eta_f$  is the fin efficiency. Subscripts “i” and “o” stand for inner and outer sides,  $\Delta x$  is the thickness of the wall separating the refrigerant from external fluid,  $k_w$  and  $A_m$  are the thermal conductivity and mean area of the wall.  $R''_f$  is the resistance due to fouling.

The fouling due to deposition of scale on the fin side of an air cooled condenser usually has little effect since  $1/h_{co}$  is rather large. In some cases an allowance may be made for imperfect contact between the fins and the tubes, however it is difficult to evaluate. It is negligible for good construction. The fouling resistance for the inside of the tube is not negligible and must be included. For an externally finned tube condenser, the overall heat transfer coefficient based on the external area,  $U_o$  is given by:



$$U_o = \frac{1}{\frac{A_o}{h_i A_i} + \frac{R''_{f,i} A_o}{A_i} + \frac{A_o r_i \ln(r_o/r_i)}{A_i k_w} + \frac{A_o}{[h_o (A_f \eta_f + A_b)]_o}} \quad (22.7)$$

In the above expression  $A_o$  is the total external area ( $A_f + A_b$ ),  $h_i$  and  $h_o$  are the inner and outer convective heat transfer coefficients, respectively and  $r_i$ ,  $r_o$  are the inner and outer radii of the tube, respectively.

For water-cooled condensers without fins, the expression for overall heat transfer coefficient simplifies to:

$$U_o = \frac{1}{\frac{A_o}{h_i A_i} + \frac{R''_{f,i} A_o}{A_i} + \frac{A_o r_i \ln(d_o/d_i)}{A_i k_w} + \frac{1}{h_o}} \quad (22.8)$$

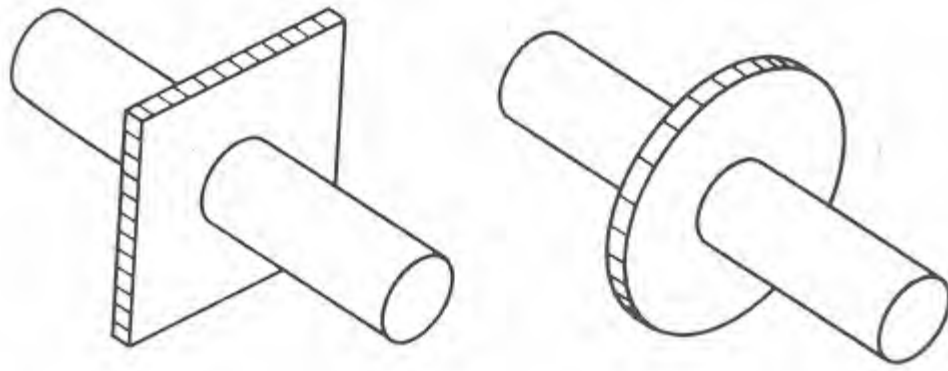
The condensation heat transfer coefficient is of the order of 7000 W/m<sup>2</sup>-K for ammonia. However it is of the order of 1700 W/m<sup>2</sup>-K for synthetic refrigerants such as R 12 and R 22, whereas the waterside heat transfer coefficient is high in both the cases for turbulent flow. Hence it is advisable to add fins on the side where the heat transfer coefficient is low. In case of R 12 and R 22 condensers the tubes have integral external fins to augment the heat transfer rate. This is easily seen if the overall heat transfer coefficient is written in terms of inside area as follows.

$$\frac{1}{U_i} = \frac{1}{h_i} + \frac{r_i \ln(d_o/d_i)}{k_w} + \frac{1}{h_o} \frac{A_i}{A_o} + R''_{f,i} \quad (22.9)$$

It can be observed that by increasing the area ratio  $A_o/A_i$ , that is the outside surface area the overall heat transfer coefficient can be increased.

### Fin efficiency:

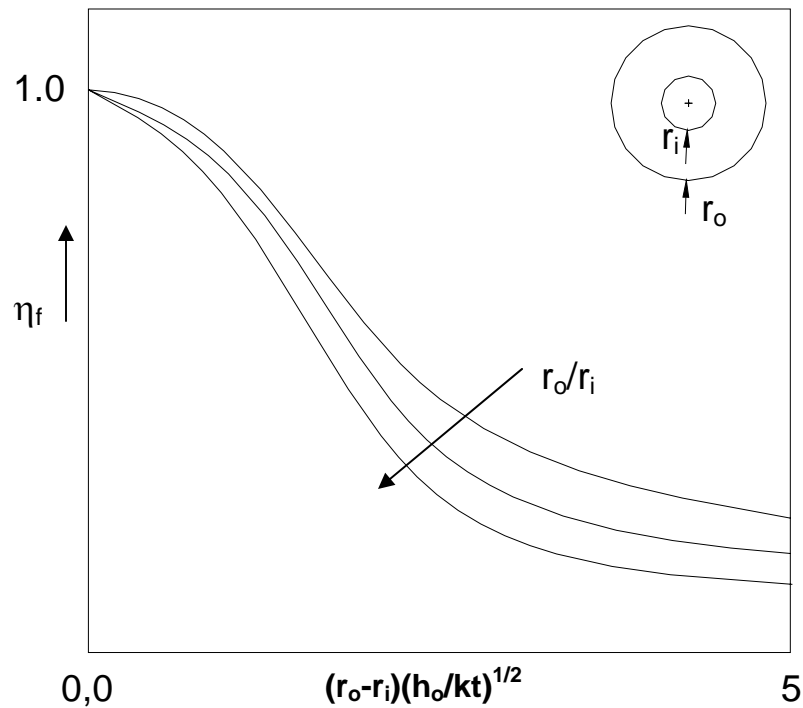
In finned tube condensers, the fin efficiency depends on the type and material of the fin and on fluid flow characteristics. Expressions for fin efficiency can be derived analytically for simple geometries, however, for complex geometries, the fin efficiency has to be obtained from actual measurements and manufacturers' catalogs. The most commonly used fin configuration is the plate-fin type as shown in Fig. 22.3. The plate-fin is often approximated with an equivalent annular fin as shown in Fig.22.10. This is done as analytical expressions and charts for the efficiency of annular fin have been obtained. Figure 22.11 shows a typical efficiency chart for annular fins. In the figure,  $r_o$  and  $r_i$  are the outer and inner radii of the annular fin,  $h_o$  is the external heat transfer coefficient,  $k$  is the thermal conductivity of fin material and  $t$  is the thickness of the fin.



**Rectangular plate-fin segment**

**Equivalent annular fin**

*Fig.22.10: Approximating a plate-fin with an equivalent annular fin*



*Fig.22.11: Fin efficiency curves for an annular fin*

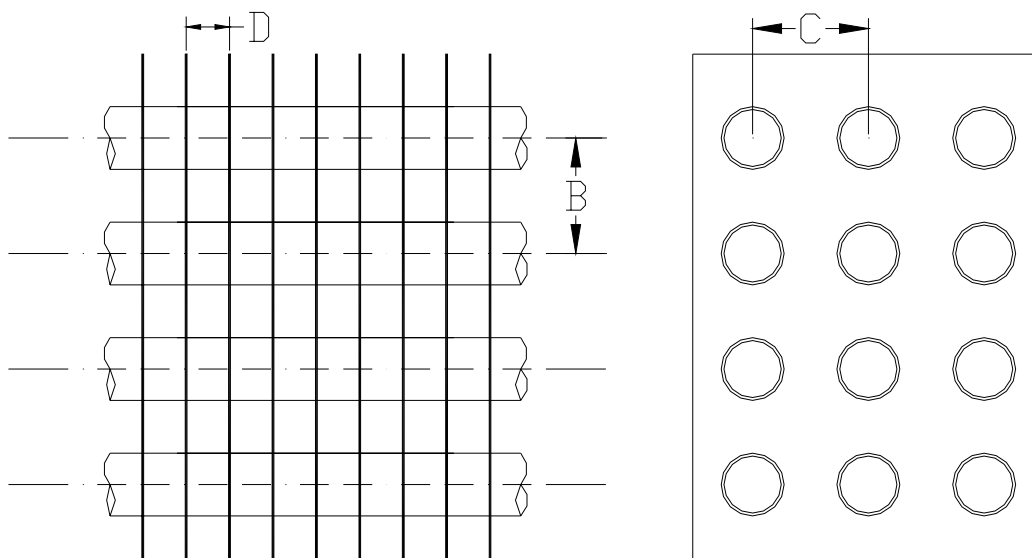
As shown in Fig.22.3, if the spacing between the tubes is  $B$  units within a row and  $C$  units between rows. Then the area of the fin is given by  $(B \times C - \pi r_1^2)$ . Now the outer radius ( $r_2$ ) of an equivalent annular fin is obtained by equating the fin areas, i.e.,

$$B \times C - \pi r_1^2 = \pi (r_2^2 - r_1^2) \therefore r_2 = \sqrt{(B \times C / \pi)} \quad (22.10)$$

Then the efficiency of the rectangular plate-fin is obtained from the efficiency of an equivalent annular fin having an inner radius of  $r_1$  and outer radius of  $r_2$  ( $= \sqrt{B \times C/\pi}$ ).

#### 22.4.4. Heat transfer areas in finned tube condensers:

Figure 22.3 shows the schematic diagram of a condenser or a cooling coil with tubes and fins. The air flows through the passages formed by the fins. Figure 22.12 shows a section of the plate fin-and-tube condenser and its side view.



**Fig.22.12:** A portion of a plate fin-and-tube type condenser and its side view

The heat transfer takes place from the fins and the exposed part of the tube. Hence heat transfer occurs from following areas

1. Bare tube area between the consecutive fins,  $A_b$
- b) Area of the fins,  $A_f$

These areas are expressed in terms per  $m^2$  of face area and per row. Face area  $A_{face}$  is the area of condenser seen from outside, the actual flow area is less than the face area since fins have finite thickness. Further, as air flows through it, it has to pass between the narrow passage between the tubes. The flow area is minimum at these locations. This will be denoted by  $A_c$ . To find these areas we consider condenser of 1.0 m height and 1.0 m width as shown in Fig.22.12, so that the face area is  $1 m^2$ . All the dimensions are in mm. Following nomenclature is used.

**B:** Vertical spacing between the tubes in a row, mm  
**C:** Spacing between the tube in different rows, mm  
**t:** Thickness of the fins, mm  
**D:** Centre-to center spacing between the fins, mm  
 **$d_o$ :** Outer diameter of the tubes, mm  
 **$d_i$ :** Inner diameter of the tubes, mm

No. of tubes per m height =  $(1000/B)$  (tubes per  $m^2$  face area per row)  
 No. of fin passages per m width =  $(1000/D)$  (no. of passages per  $m^2$  face area)  
 No. of fins per  $m^2$  face area =  $1 + 1000/D \approx 1000/D$   
 Width of each passage =  $(D - t) / 1000$  (in meters)

Then the various areas are as follows:

Bare tube area,  $A_b$  = (tube perimeter) x (number of fin passages) x (number of tubes) x (width of each passage) =  $(\pi d_o/1000) (1000/D) (1000/B) (D - t)/1000$

$$A_b = \frac{D - t}{DB} \pi d_o \quad m^2 \text{ per } m^2 \text{ face area per row} \quad (22.11)$$

Fin Area,  $A_f$  = (number of fins) (two sides of fins) {width of fin per row – number of tubes x area of cross section of each tube} =  $(1000/D)(2)\{1 \times C/1000 - (1000/B) \pi(d_o/1000)^2/4\}$

$$A_f = \frac{2}{D} \left[ C - \frac{\pi d_o^2}{4B} \right] m^2 \text{ per } m^2 \text{ face area per row} \quad (22.12)$$

Minimum flow area,  $A_c$  = (number of fin passages) x (width of each passage) x (height – number of tubes per row x diameter of tube) =  $(1000/D)\{(D - t)/1000\}\{1 - (1000/B)(d_o/1000)\}$

$$A_c = \frac{D - t}{D} \left[ 1 - \frac{d_o}{B} \right] m^2 \text{ per } m^2 \text{ face area per row} \quad (22.13)$$

Total heat transfer area  $A_o$  = Bare tube area + Fin area

$$A_o = A_b + A_f \quad m^2 \text{ per } m^2 \text{ face area per row} \quad (22.14)$$

Wetted Perimeter,  $P$  = total heat transfer area/length in flow direction

$$P = A_o / (C/1000) \quad (22.15)$$

Hydraulic diameter,  $D_h$  =  $4 A_c / \text{wetted perimeter}$

$$D_h = \frac{4 C A_c}{1000 A_o} \quad (22.16)$$

The Reynolds number and the Nusselt numbers are based upon hydraulic diameter.

Inside heat transfer area,  $A_i = (\pi d_i/1000) \times (\text{Number of tubes}) = \pi d_i/B$

$$A_i = \pi d_i/B \quad (22.17)$$

#### 22.4.5. Estimation of heat transfer coefficients:

##### 1. . Air side heat transfer coefficients in air cooled condensers:

##### 1. . Flow over finned surfaces:

As discussed before, in these condensers, the refrigerant flows through the tubes, while air flows over the finned tubes. The forced convection heat transfer coefficient for the air-side depends upon, the type of fins, fin spacing, fin thickness tube diameters etc. It can be evaluated experimentally for particular fin and tube arrangement. Kays and London (1955) have carried out extensive measurements on different types of fin and tube arrangements. They have presented the data in the forms of plot of Colburn j-factor ( $St.Pr^{2/3}$ ) vs. Reynolds number (Re) for various geometries. On the average, following correlation is a good fit to their data for various geometries.

$$Nu = 0.117 Re^{0.65} Pr^{1/3} \quad (22.17)$$

The Nusselt number and Reynolds numbers are based upon hydraulic diameter defined earlier in Eqn.(22.16).

Another simple expression has been proposed Air conditioning and Refrigeration Institute, Arlington Va.(1972) , which is as follows

$$h_o = 38 V_f^{0.5} \quad (22.18)$$

Where,  $V_f$  is the face velocity in m/s and  $h_o$  is in  $W/m^2.K$

#### **b) Correlations for Pressure drop**

Rich (1974) has carried out extensive measurements over the fin-tube heat exchangers and has given pressure drop plots. A correlation fitted to his data is given in Table 22.2 for various fin spacing for pressure drop in Pa per row. The velocity is the face velocity in m/s

Number of fins/m	315	394	472	531
$\Delta p$ (Pa per row)	$7.15 V^{1.56}$	$8.5 V^{1.56}$	$9.63 V^{1.56}$	$11 V^{1.56}$

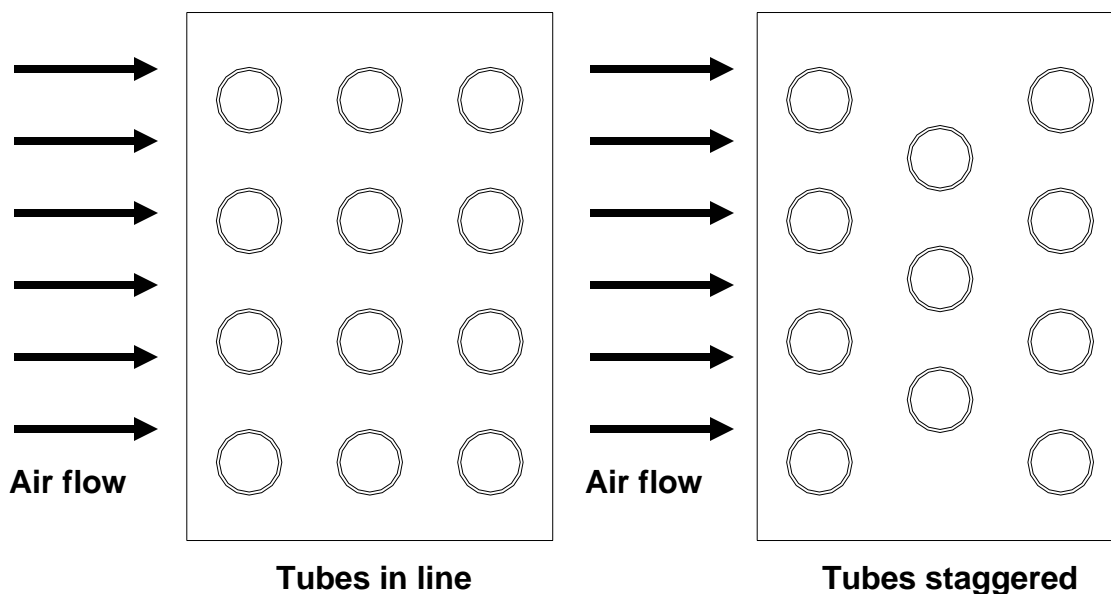
**Table 22.2:** Pressure drop correlations for various fin spacings (Rich, 1974)

**ii. Flow over tube banks:**

**a) Heat transfer**

Grimson has given correlations for average heat transfer coefficient for forced convection from tube banks in cross flow for staggered as well as in-line arrangement of tubes as shown in Fig. 22.13. As mentioned earlier, face area  $A_f$  of the heat exchanger is the area seen from the flow direction and  $Q_f$  is the volume flow rate of flow then face velocity  $V_f$  is given by:

$$V_f = Q_f/A_f \quad (22.19)$$



**Fig.22.13:** Schematic diagram of plate fin-and-tube condenser with Tubes-in-line and tubes staggered

The maximum velocity occurs between the tubes since the tubes block a part of the flow passage. If  $B$  is the spacing between tubes in the face and  $C$  is the tube spacing between rows, and  $d_o$  is the tube diameter then maximum velocity is given by

$$V_{\max} = V_f B / (B - d_o) \quad (22.20)$$

The Reynolds and Nusselt number are defined as follows for this case:

$$Re = \frac{\rho V_{\max} d_o}{\mu} \quad \text{and} \quad Nu = \frac{h d_o}{k} \quad (22.21)$$

The Grimson's correlation is as follows

$$Nu = C Re^n Pr^{1/3} \quad (22.22)$$

Where the constants  $C$  and  $n$  are dependent upon Reynolds number and are given in Table 22.3.

Reynolds number, Re	Constant C	Constant n
0.4 to 4	0.989	0.33
4 to 40	0.911	0.385
40 to 4000	0.683	0.466
4000 to 40000	0.193	0.618
40000 to 400000	0.0266	0.805

**Table 22.3:** Values of constants  $C$  and ' $n$ ' used in Eqn.(22.22)

### b) Pressure drop

O.L. Pierson and E.C. Hoge have given the correlation for pressure drop for flow over tube banks as follows:

$$\Delta p = f N V^2 / 2 \quad (22.23)$$

Where,  $f$  is the friction factor and  $N$  is the number of rows. The friction factor is given by

$$f = Re^{-0.15} \left[ 0.176 + \frac{0.32b}{(a-1)^{0.43} + 1.13/b} \right] \quad \text{for tubes in - line}$$

$$f = Re^{-0.16} \left[ 1.0 + \frac{0.47}{(a-1)^{1.08}} \right] \quad \text{for staggered tubes (22.24)}$$

where,  $a = B/d_o$  and  $b = C/d_o$

### iii. Free convection over hot, vertical flat plates and cylinders:

Constant wall temperature:

$$\text{Average Nusselt number, } \bar{Nu}_L = \left( \frac{\bar{h}_c L}{k_f} \right) = c (Gr_L Pr)^n = c Ra_L^n \quad (22.25)$$

where  $c$  and  $n$  are 0.59 and  $\frac{1}{4}$  for laminar flow ( $10^4 < Gr^L.Pr < 10^9$ ) and 0.10 and  $\frac{1}{3}$  for turbulent flow ( $10^9 < Gr^L.Pr < 10^{13}$ )

In the above equation,  $Gr_L$  is the average Grashoff number given by:

$$\text{Average Grashoff Number } Gr_L = \frac{g\beta (T_w - T_\infty) L^3}{\nu^2} \quad (22.26)$$

where  $g$  is the acceleration due to gravity,  $\beta$  is volumetric coefficient of thermal expansion,  $T_w$  and  $T_\infty$  are the plate and the free stream fluid temperatures, respectively and  $\nu$  is the kinematic viscosity. Correlations for other conditions are presented in Chapter 7.

### b) Water side heat transfer coefficients in water cooled condensers:

In water cooled condensers, the water flows through the tubes. The water flow is normally turbulent, hence one can use Dittus-Boelter equation given by:

$$Nu_d = 0.023 Re_d^{0.8} Pr^{0.4} \quad (22.27)$$

If the viscosity variation is considerable, then one can use Seider-Tate equation given by:

$$Nu_d = 0.036 Re_d^{0.8} Pr^{1/3} (\mu/\mu_w)^{0.14} \quad (22.28)$$

If the Reynolds number on water side is less than 2300, then the flow will be laminar, hence one has to use the correlations for laminar flow. For example, if the flow is laminar and not fully developed, then one can use Hausen's correlation given by:

$$\overline{Nu}_d = 3.66 + \frac{0.0668(D_i/L)Pe}{1 + 0.04[(D_i/L)Pe]^{2/3}} \quad (22.29)$$

where  $Pe$  is the Peclet number =  $Re_d.Pr$

#### 1. . Condensation heat transfer coefficient:

When refrigerant vapour comes in contact with the surface whose temperature is lower than the saturation temperature of refrigerant at condenser pressure, the refrigerant condenses. Depending upon the type of the surface, condensation can be filmwise or dropwise. Even though dropwise condensation yields higher heat transfer coefficients compared to filmwise condensation, normally design calculations are based on filmwise condensation. This is due to the reason that it is difficult to maintain dropwise condensation continuously as the surface characteristics may undergo change with time. In filmwise condensation, the condensed refrigerant liquid forms a film over the condensing



surface. This liquid film resists heat transfer, hence, for high condensation heat transfer rates, the thickness of the liquid film should be kept as small as possible. This requires continuous draining of condensed liquid so that the vapour has better contact with the heat transfer surface of the condenser. Since the rate at which condensed liquid is drained depends among other factors on the orientation of the surface, the condensation heat transfer coefficients vary widely with orientation.

### **Outside Horizontal Tubes**

A typical correlation known as Nusselt's correlation for film-wise condensation outside a bank of horizontal tubes is as follows:

$$h_o = 0.725 \left[ \frac{k_f^3 \rho_f (\rho_f - \rho_g) g h_{fg}}{ND_o \mu_f \Delta t} \right]^{0.25} \quad (22.30)$$

The density of liquid is much more than that of vapour hence this may be approximated by

$$h_o = 0.725 \left[ \frac{k_f^3 \rho_f^2 g h_{fg}}{ND_o \mu_f \Delta t} \right]^{1/4} \quad (22.31)$$

This expression is exactly valid for still vapour. In this expression subscript  $f$  refers to the properties of saturated liquid, which are evaluated at mean film temperature of  $(t_{wo} + t_r)/2$ .  $D_o$  is the outer diameter of the tube and  $N$  is the average number of tubes per column.

Some of the features of this correlation are as follows:

- i. As thermal conductivity  $k_f$  increases, the heat transfer coefficient increases since conduction thermal resistance of the condensate film decreases.
- ii. Similarly a decrease in viscosity or increase in density will offer less frictional resistance and cause rapid draining of the condensate, thereby causing an increase in heat transfer coefficient.
- iii. A high value of latent heat  $h_{fg}$  means that for each kW of heat transfer there will be smaller condensate thickness and higher heat transfer coefficient.
- iv. An increase in diameter means larger condensate thickness at the bottom and hence a smaller heat transfer coefficient.
- v. A large value of temperature difference will lead to more condensation and larger condensate thickness and will lead to a smaller heat transfer coefficient.
- vi. An increase in number of tubes will lead to larger condensate thickness in the lower tubes leading to smaller heat transfer coefficient.

In actual practice the vapour will not be still but it will move with some velocity and the condensate will splash and ripples will be caused which may lead to larger value of heat transfer coefficient. Hence the above equation gives a very conservative estimate of condensation heat transfer coefficient.

### **Outside Vertical Tube :**

For laminar flow the average heat transfer coefficient by Nusselt's Correlation for condensation over a vertical tube is as follows

$$h_0 = 1.13 \left[ \frac{k_f^3 \rho_f (\rho_f - \rho_g) g h_{fg}}{L \mu_f \Delta t} \right]^{0.25} \quad \text{where } L \text{ is the tube length} \quad (22.32)$$

This may be used in laminar flow up to  $Re_f = 1800$ , where  $Re_f = 4 \dot{m} / (\pi \mu_f D)$  Kirkbride has rearranged this in terms of *condensation number*  $Co$ , which is defined as follows:

$$Co = h_0 \left[ \frac{\mu_f^2}{k_f^3 \rho_f^2 g} \right]^{1/3} = 1.514 Re_f^{-1/3} = 1.514 Re_f^{-1/3} \quad (22.33)$$

For turbulent flow :  $Re_f > 1800$  , the Kirkbride Correlation is as follows:

$$Co = h_0 \left[ \frac{\mu_f^2}{k_f^3 \rho_f^2 g} \right]^{1/3} = 0.0077 Re_f^{0.4} \quad (22.34)$$

### **Condensation Inside Tubes**

Condensation heat transfer inside tube causes a reduction in the area of condensation due to liquid collecting in the bottom of the tubes. The draining of the condensate may retard or accelerate the vapour flow depending upon whether it flows in same direction as the vapour or in opposite direction. Here flow rate of vapour considerable influences the heat transfer coefficient.

#### **1. . Chaddock and Chato's Correlation**

Chaddock and Chato suggested that condensation heat transfer coefficient inside tubes is 0.77 times that of Nusselt's heat transfer coefficient outside the tubes particularly if the vapour Reynolds number  $Re_g = 4 \dot{m} / (\pi \mu_g D_i) < 35000$ . This gives the average value of heat transfer coefficient over the length of the tube.

$$H_{TP} = 0.77 h_0 \quad (22.35)$$

$$h_{TP} = 0.555 \left[ \frac{k_f^3 \rho_f (\rho_f - \rho_g) g h'_{fg}}{D_i \mu_f \Delta t} \right]^{0.25} \quad (22.36)$$

Where the modified enthalpy of evaporation is defined as  $h'_{fg} = h_{fg} + 3 C_{pf} \Delta t/8$ ,  $\Delta t$  is the difference between the temperature of condensing refrigerant and temperature of the surface.

(b) *Cavallini Zecchin Correlation*

This correlation represents the condensation heat transfer coefficient in a manner similar to Dittus-Boelter equation for turbulent flow heat transfer inside tubes. The constant is different from that equation and an equivalent Reynolds number is used to take care of two-phase flow and incomplete condensation. The local values of heat transfer coefficient can also be found if the quality distribution is known.

$$\begin{aligned}
 h_{TP} &= 0.05 \text{Re}_{eq}^{0.8} \text{Pr}_f^{0.33} k_f / D_i \\
 \text{Re}_{eq} &= \text{Re}_f (1 - x) + x \left( \frac{\mu_g}{\mu_f} \right) \left( \frac{\rho_f}{\rho_g} \right)^{0.5} \text{Re}_g \\
 \text{Where, } \text{Re}_g &= \frac{4\dot{m}}{\pi D_i \mu_g} \text{ and } \text{Re}_f = \frac{4\dot{m}}{\pi D_i \mu_f} \qquad (22.37)
 \end{aligned}$$

© *Traviss et al. Correlation*

This correlation uses Lockhart-Martinelli parameter, which takes into account incomplete condensation. This can also be used for evaluation of local heat transfer coefficient if the quality of mixture is known. The correlation covers a wide range of Reynolds numbers defined as  $\text{Re}_l = (1 - x) \text{Re}_f$ , where  $\text{Re}_f$  is the Reynolds number if all the refrigerant flows in liquid phase.

$$\text{Nu} = \left[ \frac{\text{Pr}_f \text{Re}_l^{0.9}}{F_2} \right] F_{tt} \quad \text{for } 0.15 < F_{tt} < 15 \qquad (22.38)$$

$$F_{tt} = 0.15 [X_{tt}^{-1} + 2.85 X_{tt}^{-0.467}] \quad \text{and}$$

$$F_2 = 0.707 \text{Pr}_f \text{Re}_l \text{ for } \text{Re}_l < 50 \quad \text{where, } \text{Re}_l = (1 - x) \text{Re}_f$$

$$F_2 = 5 \text{Pr}_f + 5 \ln [1 + \text{Pr}_f (0.09636 \text{Re}_l^{0.585} - 1)] \quad : 50 < \text{Re}_l < 1125$$

$$F_2 = 5 \text{Pr}_f + 5 \ln [1 + 5 \text{Pr}_f] + 2.5 \ln [0.00313 \text{Re}_l^{0.812}] \quad : \text{Re}_l > 1125$$

$$X_{tt} = [(1 - x)/x]^{0.9} (\rho_g / \rho_f)^{0.5} (\mu_f / \mu_g)^{0.1} = \text{Lockhart - Martinelli parameter}$$

1. . *Shah's Correlation*

This correlation takes into account the pressure of the refrigerant also in addition to the quality of the mixture. This can also be used to find the local condensation heat transfer coefficient. The heat transfer coefficient is a product

of heat transfer coefficient given by Dittus-Boelter equation and an additional term.

$$h_{TP} = h_L \left[ (1-x)^{0.8} + \frac{3.8 x^{0.76} (1-x)^{0.04}}{p_r^{0.38}} \right]$$

where,  $p_r = p/p_{\text{critical}} = \text{reduced pressure}$

$$h_L = 0.023 Re_f^{0.8} Pr_f^{0.4} k_f / D_i \quad (22.40)$$

$$\bar{h}_{TP} = h_{TP} [0.55 + 2.09/p_r^{0.38}] : \text{avg value of h. t. coeff. at } x = 0.5$$

### 1. . Akers, Dean and Crosser Correlation

Akers, Dean and Crosser have proposed following correlation when the rate of condensation or the length is very large. This is very similar to Dittus-Boelter correlation for turbulent heat transfer in tubes, except the constant is different.

$$\begin{aligned} \frac{hD_i}{k_f} &= 5.03 Re_m^{1/3} Pr_f^{1/3} && : Re_g < 5 \times 10^4 \\ &= 0.0265 Re_m^{0.8} Pr_f^{1/3} && : Re_g > 5 \times 10^4 \\ \text{where } Re_m &= Re_f [1 + (\rho_f / \rho_g)^{0.5}] \end{aligned} \quad (22.41)$$

In this correlation the heat transfer coefficient is independent of temperature difference and it increases with the increase in liquid Reynolds number,  $Re_f$ . Sometimes, it overestimates the heat transfer coefficient.

### Fouling Factor

The condenser tubes are clean when it is assembled with new tubes. However with usage some scale formation takes place in all the tubes and the value of overall heat transfer coefficient decreases. It is a standard practice to control the hardness of water used in the condenser. Even then it is good maintenance practice to de-scale the condenser once a year with 2% HCl or muric acid solution. Stoecker suggests the following values of deposit coefficients.

$$\begin{aligned} R''_f &= 0.00009 \text{ m}^2 \cdot \text{K/W} \text{ for R12 and R-22 with copper tubes} \\ R''_f &= 0.000178 \text{ m}^2 \cdot \text{K/W} \text{ for steel tubes with ammonia} \end{aligned}$$

## 22.5. Effect of air and non-condensables:

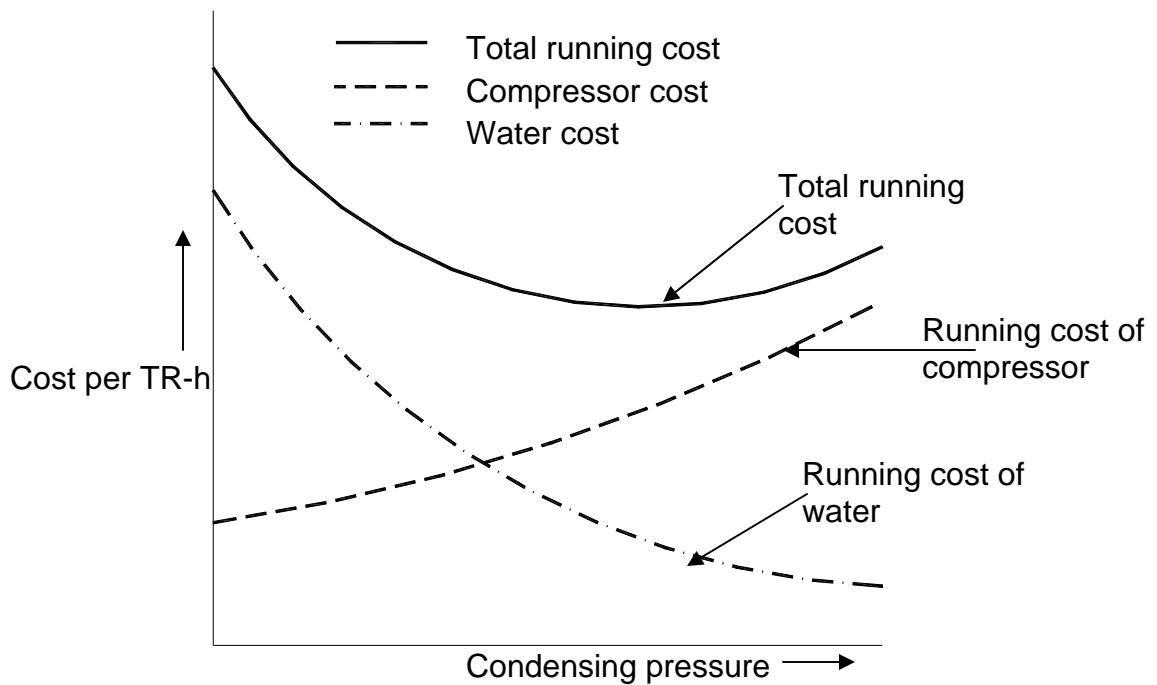
This is usually a problem with high boiling point refrigerants such as R 11, R 113 and R718 (water), which operate under vacuum leading to air leakage into the system. In addition, some air may be left behind before the system is

evacuated and charged with refrigerant. If some non-condensable gases or air enters the system, it will collect in the condenser where they affect performance in two ways:

1. Condensation takes place at saturation pressure corresponding to condenser pressure, which will be the partial pressure of refrigerant in mixture of refrigerant and air in this case. The air will have its partial pressure proportional to its amount in the condenser. The total pressure will be the sum of these two partial pressures, which will be high and the compressor has to work against this pressure ratio hence the work requirement will increase.
2. Non-condensable gases do not diffuse throughout the condenser as the refrigerant condenses. They cling to the tubes and reduce the precious heat transfer area. The reduction in heat transfer area causes the temperature difference between cold water and refrigerant to increase. This raises the condenser temperature and the corresponding pressure thereby reducing the COP.

## 22.6. Optimum condenser pressure for lowest running cost

The total running cost of a refrigeration system is the sum of costs of compressor power and the cost of water. The cost of water can be the cost of municipal water or the cost of running a cooling tower. The compressor power increases as the condenser temperature or the pressure increases for fixed evaporator temperature. The water from a cooling tower is usually available at a fixed temperature equal to wet-bulb temperature of air plus the approach of the cooling tower. As the condenser temperature increases the overall *log mean temperature difference* increases, as a result lower mass flow rate of cooling water is required. This reduces the cost of water at higher condenser temperatures. Figure 22.14 shows the general trend of the total running cost of a refrigeration system. It is observed that there is a condenser pressure at which the running cost is minimum and it is recommended that the system should be run at this pressure. A complete analysis of the cost should actually be carried out which should include the first cost of the whole system, the interest on capital, the depreciation, the maintenance cost the operator cost etc. The final selection of the system and operating conditions should be such that the cost is the least over the running life of the system.



**Fig.22.14:** Variation of total running cost of a refrigeration system with condensing pressure

### Questions & answers:

1. Which of the following statements are TRUE?

- a) Natural convective type condensers are used in small capacity systems as the overall heat transfer coefficient obtained is small
- b) Compared to natural convection type, forced convection type condensers have smaller weight per unit capacity
- c) Evaporative condensers are normally used in small capacity systems
- d) Compared to water-cooled condensers, the water consumption is high in evaporative condensers

**Ans.: a) and b)**

2. Which of the following statements are TRUE?

- a) Compared to water cooled condensers, the maintenance cost is low in air cooled condensers
- b) Normally, systems with water cooled condensers operate at lower condensing temperature as compared to systems with air cooled condensers
- c) The initial cost of water cooled condenser is high compared to air cooled condenser
- d) All of the above

**Ans.: d)**

3. Which of the following statements are TRUE?

- a) Heat Rejection Ratio increases as evaporator temperature increases and condenser temperature decreases
- b) Heat Rejection Ratio increases as evaporator temperature decreases and condenser temperature increases
- c) For the same evaporator and condenser temperatures, Heat Rejection Ratio of open type compressors is small compared to hermetic compressors
- d) The required size of condenser increases as Heat Rejection Ratio decreases

**Ans.: b) and c)**

4. The approximation of constant temperature in a condenser generally holds good as:

- a) The heat transfer coefficient in de-superheating zone is larger than that in condensing zone
- b) The heat transfer coefficient in de-superheating zone is smaller than that in condensing zone
- c) The temperature difference between refrigerant and external fluid in de-superheating zone is large compared to condensing zone
- d) The temperature difference between refrigerant and external fluid in de-superheating zone is small compared to condensing zone

**Ans.: b) and c)**

5. Which of the following statements is TRUE?

- a) In water-cooled condensers using ammonia, fins are used on refrigerant side due to low condensing heat transfer coefficient
- b) In water-cooled condensers using synthetic refrigerants, fins are used on refrigerant side due to low condensing heat transfer coefficient
- c) Fouling resistance on external fluid side is negligible in water-cooled condensers
- d) Fouling resistance on external fluid side is negligible in air-cooled condensers

**Ans.: b) and d)**

6. Presence of non-condensable gases in a condenser:

- a) Increases the condenser pressure
- b) Decreases condenser pressure
- c) Increases resistance to heat transfer
- d) Decreases COP

**Ans.: a), b) and d)**

7. The average condensing heat transfer coefficient for a refrigerant condensing on a single horizontal tube is found to be  $4000 \text{ W/m}^2\cdot\text{K}$ . Now another tube is added directly below the first tube. Assuming everything else to remain constant, what will be the new average condensing heat transfer coefficient?

**Ans.:** From Nusselt's correlation for condensation heat transfer coefficient on the outside of a horizontal tube, we find that when everything else remains constant:

$$h_o \propto \left[ \frac{1}{N} \right]^{1/4} \text{ where } N \text{ is the number of tubes in a vertical row.}$$

From the above equation, the ratio of condensing heat transfer coefficient with 1 tube and 2 tubes is given by:

$$\frac{h_{o,2}}{h_{o,1}} = \left[ \frac{1}{2} \right]^{1/4} = 0.8409$$

$$\Rightarrow h_{o,2} = h_{o,1} \times 0.8409 = 3363.6 \text{ W/m}^2\cdot\text{K} \quad (\text{Ans.})$$

8. A refrigeration system of 55 kW cooling capacity that uses a water-cooled condenser has a COP of 5.0. The overall heat transfer coefficient of the condenser is  $450 \text{ W/m}^2\cdot\text{K}$  and a heat transfer area of  $18 \text{ m}^2$ . If cooling water at a flow rate of 3.2 kg/s enters the condenser at a temperature of  $30^\circ\text{C}$ , what is the condensing temperature? Take the specific heat of water as  $4.18 \text{ kJ/kg}\cdot\text{K}$ .

**Ans.:**

The Heat Rejection Ratio of the system is equal to:

$$\text{HRR} = 1 + 1/\text{COP} = 1.2$$

Hence condenser heat rejection rate,  $Q_c$

$$Q_c = \text{Refrigeration capacity} \times \text{HRR} = 66 \text{ kW}$$

Hence the LMTD of the condenser is equal to:

$$\text{LMTD} = Q_c / (U.A) = 8.148^\circ\text{C}$$

$$\text{The exit temperature of water, } T_{w,e} = T_{w,i} + Q_c / (m_w \times c_p) = 34.93^\circ\text{C}$$

From the expression for LMTD;  $\text{LMTD} = (T_{w,e} - T_{w,i}) / [\ln(T_c - T_{w,i}) / (T_c - T_{w,e})]$

$$\text{We find condensing temperature, } T_c = 40.86^\circ\text{C} \quad (\text{Ans.})$$



9. Find the length of tubes in a two pass 10 TR Shell-and-Tube R-22 based, water-cooled condenser with 52 tubes arranged in 13 columns. The Heat Rejection Ratio (HRR) is 1.2747. The condensing temperature is 45°C. Water inlet and outlet temperature are 30°C and 35°C respectively. The tube outer and inner diameters are 14.0 and 16.0 mm respectively.

**Ans.: Average properties of R 22 and water are:**

<u>Water</u>	<u>R 22</u>
$\mu_w = 7.73 \times 10^{-4} \text{ kg/m-s}$	$\mu_f = 1.8 \times 10^{-4} \text{ kg/m-s}$
$k_w = 0.617 \text{ W/m-K}$	$k_f = 0.0779 \text{ W/m-K}$
$\rho_w = 995.0 \text{ kg/m}^3$	$\rho_f = 1118.9 \text{ kg/m}^3$
$C_{pw} = 4.19 \text{ kJ/kg-K}$	$h_{fg} = 160.9 \text{ kJ/kg}$
$Pr_w = 5.25$	

The fouling resistance on water side and thermal conductivity of copper are:

$$R''_{f,i} = 0.000176 \text{ m}^2\text{-K/W} \quad k_{Cu} = 390 \text{ W/m-K}$$

• Heat transfer rate in condenser,  $Q_c$

$$Q_c = \text{HRR} \cdot Q_e = 1.2747 \times 10 \times 3.5167 = 44.83 \text{ kW}$$

• Required mass flow rate of water,  $m_w$

$$Q_c = m_w C_{p,w} (T_{w,o} - T_{w,i})$$

$$m_w = Q_c / C_{p,w} (T_{w,o} - T_{w,i}) = 44.83 / 4.19 \times 5 = 2.14 \text{ kg/s}$$

Since it is a 2-pass condenser with 52 tubes, water flow through each tube is given by:

$$m_{w,i} = m_w / 26 = 0.0823 \text{ kg/s}$$

Reynolds number for water side,  $Re_w$

$$Re_w = 4m_{w,i} / (\pi d_i \mu_w) = 4682.6 \quad (\Rightarrow \text{Turbulent flow})$$

Heat transfer coefficient on water side,  $h_i$

•From Dittus-Boelter Equation:

$$Nu_w = (h_i d_i / k_w) = 0.023 Re_w^{0.8} Pr_w^{0.4} = 68.96$$

$$h_i = Nu_w \times k_w / d_i = 3039 \text{ W/m}^2 \cdot \text{K}$$

Condensation heat transfer coefficient,  $h_o$

Nusselt's correlation will be used to estimate  $h_o$ :

$$\text{Number of tubes per row, } N = 52/13 = 4$$

Substituting the above and other property values in Nusselt's correlation, we obtain:

$$h_o = 2175 / \Delta T^{0.25}$$

$\Delta T = T_{ref} - T_s$  is not known a priori, hence, a trial-and-error method has to be used

For water-cooled condensers without fins; the overall heat transfer coefficient is given by:

$$U_o = \frac{1}{\frac{A_o}{h_i A_i} + \frac{R''_{f,i} A_o}{A_i} + \frac{A_o r_i \ln(d_o / d_i)}{A_i k_w} + \frac{1}{h_o}}$$

Substituting the values of various parameters, we obtain:

$$\frac{1}{U_o} = 0.0005781 + \frac{1}{h_o}$$

First trial: Assume  $\Delta T = 5^\circ\text{C}$

Then condensation heat transfer coefficient,

$$h_o = 2175 / \Delta T^{0.25} = 1454.5 \text{ W/m}^2 \cdot \text{K}$$

Then the overall heat transfer coefficient is given by:

$$(1/U_o) = 0.0005781 + (1/h_o) = 0.0012656 \text{ m}^2 \text{K/W}$$

$$\text{Hence, } U_o = 790.2 \text{ W/m}^2 \cdot \text{K}$$

$$Q_c = U_o A_o LMTD = 44.83 \text{ kW}$$

$$LMTD = (T_{w,o} - T_{w,i}) / [\ln(T_c - T_{w,i}) / (T_c - T_{w,o})] = 12.33 \text{ K}$$

$$\text{Therefore, } A_o = 4.6 \text{ m}^2$$

Now we have cross-check for the initially assumed value of  $\Delta T = 5^\circ\text{C}$ :

$$\Delta T = Q_c / (h_o \cdot A_o)$$

$$\bullet \text{Substituting the value; } \Delta T_{\text{calc}} = 6.7 \text{ K}$$

Since the calculated value is not equal to the assumed value, we have to repeat the calculation with  $\Delta T = 7 \text{ K}$  (**Second trial**)

Repeating the above calculations with  $\Delta T$  of 7K, we obtain  $\Delta T_{\text{calc}} = 6.96 \text{ K}$

Since, this value is sufficiently close to the 2<sup>nd</sup> guess value of 7K, it is not necessary to repeat the calculations.

For 7 K temperature difference, we obtain the value of  $U_o$  to be **754 W/m<sup>2</sup>.K**

From the values of  $U_o$ , LMTD and  $Q_c$ , we obtain;

$$A_o = 4.82 \text{ m}^2$$

$$\text{Now, } A_o = 56\pi d_o L$$

**Hence, length of each tube, L = 1.713 m (Ans.)**

10. Determine the required face area of an R 12 condenser for **5 TR** refrigeration plant. The condensing temperature is  $40^\circ\text{C}$ , the system COP is **4.9** and refrigeration effect is **110.8 kJ/kg**. Air at an inlet temperature of **27°C** flows through the condenser with a face velocity of **2.5 m/s**. The inside and outside diameters of the tubes are **11.26 and 12.68 mm**, respectively. Fin efficiency is **0.73**. Other dimensions with reference to Fig. 22.12 are:

$$\mathbf{B = 43 \text{ mm; } C = 38 \text{ mm, } D = 3.175 \text{ mm, } t = 0.254 \text{ mm}}$$

**Ans.:** Various heat transfer areas are:

**1. Bare area,  $A_b$ : (m<sup>2</sup> per row per m<sup>2</sup> face area)**

$$A_b = \frac{D-t}{BD} \pi d_o = \frac{3.175 - 0.254}{43 \times 3.175} 3.14159(12.68) = 0.8523$$

2. Fin area,  $A_f$ : (m<sup>2</sup> per row per m<sup>2</sup> face area)

$$A_f = \frac{2}{D} \left[ C - \frac{\pi d_o^2}{4B} \right] = 22.087$$

3. Min.flow area,  $A_c$ :(m<sup>2</sup> /row per m<sup>2</sup> face area)

$$A_c = \frac{D-t}{D} \left[ 1 - \frac{d_o}{B} \right] = 0.6487$$

Total area,  $A_o$ : (m<sup>2</sup>/row/m<sup>2</sup> face area)

$$A_o = A_b + A_f = 22.94$$

Internal area,  $A_i$ : (m<sup>2</sup>/row/m<sup>2</sup> face area)

$$A_i = \pi d_i / B = 0.82266$$

•Hydraulic diameter,  $D_h$ : (m)

$$D_h = \frac{4 C A_c}{1000 A_o} = \frac{4(38)0.6487}{1000(22.9393)} = 4.2984 \times 10^{-3} \text{ m}$$

Area ratios:

$$A_o / A_i = 27.885$$

$$A_b / A_f = 0.03859$$

Condenser heat rejection rate,  $Q_c$ :

$$Q_c = \text{HRR} \cdot Q_e = (1 + 1/\text{COP}) \cdot Q_e = 21.17 \text{ kW}$$

Mass flow rate of refrigerant,  $m_r$ :

$$m_r = Q_e / \text{refrigeration effect} = 0.15869 \text{ kg/s}$$

Condensation Heat Transfer Coefficient:

From the properties of R12 at 40°C:

We find:

$$\text{Prandtl number, } Pr_f = 3.264$$

$$\text{Reynolds number of vapour, } Re_g = 1385 \times 10^3$$

$$\text{Reynolds number of liquid, } Re_f = 74.8 \times 10^3$$

To find condensation heat transfer coefficient inside tubes, we use Dean, Ackers and Crosser's correlation, which assumes complete condensation and uses a modified Reynolds number  $Re_m$

Substituting various property values and  $Re_f$ ,  
We obtain:

$$\text{Reynolds number, } Re_m = 431383$$

**The Nusselt number is found to be,  $Nu = 1265.9$**

Then the Condensation heat transfer coefficient,  $h_i$  is

$$h_i = 8206.7 \text{ W/m}^2\text{.K}$$

Air side heat transfer coefficient,  $h_o$ :

$$u_{max} = 2.5/A_c = 3.854 \text{ m/s}$$

$$\text{Reynolds number, } Re = U_{max} D_h / \nu = 983.6$$

$$Nu = h_o D_h / k = 0.117 Re^{0.65} Pr^{1/3} = 7.835$$

$$\text{Heat transfer coefficient, } h_o = 51.77 \text{ W/m}^2\text{-K}$$

Overall heat transfer coefficient,  $U_o$ :

$$U_o = \frac{1}{\frac{A_o}{h_i A_i} + \frac{R''_{f,i} A_o}{A_i} + \frac{A_o r_i \ln(r_o / r_i)}{A_i k_w} + \frac{A_o}{[h_o (A_f \eta_f + A_b)]_o}}$$

Substituting the values;  $U_o = 31.229 \text{ W/m}^2\text{-K}$

•Since outlet temperature of air is not given, assume this value to be 35°C; then

$$\text{LMTD} = \frac{(T_{\text{ext,o}} - T_{\text{ext,i}})}{\ln\left(\frac{T_c - T_{\text{ext,i}}}{T_c - T_{\text{ext,o}}}\right)} = \frac{(35 - 27)}{\ln\left(\frac{40 - 27}{40 - 35}\right)} = 8.3725^\circ \text{C}$$

Hence, total heat transfer area,  $A_{ot}$  is

$$A_{ot} = Q_c / (U_o \cdot \text{LMTD}) = 21.17 \times 1000 / (31.229 \times 8.3725) = 80.967 \text{ m}^2$$

Taking the number of rows to be 4;

$$A_{ot} = A_{\text{face}} \times \text{number of rows} \times A_o$$
$$A_{\text{face}} = 80.967 / (22.94 \times 4) = 0.882 \text{ m}^2$$

•Mass flow rate of air is given by:

$$m_{\text{air}} = \rho A_{\text{face}} \cdot V = 1.1774 \times 0.8824 \times 2.5 = 2.5973 \text{ kg/s}$$

Check for guess value of air outlet temperature (35°C):

$$Q_c = m_{\text{air}} C_p \Delta T$$
$$\Rightarrow \Delta T = 21.17 / (2.5973 \times 1.005) = 8.11^\circ \text{C}$$

$$\Rightarrow T_{\text{air,out}} = 35.11^\circ \text{C}$$

Since the guess value (35°C) is close to the calculated value (35.11°C), we may stop here. For better accuracy, calculations may be repeated with 2<sup>nd</sup> guess value of 5.1°C (say). The values obtained will be slightly different if other correlations are used for  $h_j$ .

# Lesson

## 23

# Condensers & Evaporators

## The specific objectives of this lesson are to:

1. Classify refrigerant evaporators as natural convection or forced convection type, flooded or dry type, refrigerant flow inside the tubes or outside the tubes (*Section 23.1*)
2. Discuss salient features of natural convection coils (*Section 23.2*)
3. Discuss salient features of flooded evaporators (*Section 23.3*)
4. Discuss salient features of shell-and-tube type evaporators (*Section 23.4*)
5. Discuss salient features of shell-and-coil evaporator (*Section 23.5*)
6. Discuss salient features of double pipe evaporators (*Section 23.6*)
7. Discuss salient features of Baudelot evaporators (*Section 23.7*)
8. Discuss salient features of direct expansion fin-and-tube type evaporators (*Section 23.8*)
9. Discuss salient features of plate surface evaporators (*Section 23.9*)
10. Discuss salient features of plate type evaporators (*Section 23.10*)
11. Discuss thermal design aspects of refrigerant evaporators (*Section 23.11*)
12. Discuss enhancement of boiling heat transfer (*Section 23.12*)
13. Discuss the concept of Wilson's plot (*Section 23.13*)

At the end of the lecture, the student should be able to:

1. Classify refrigerant evaporators and discuss the salient features of different types of evaporators
2. Perform thermal design calculations on refrigerant evaporators using various heat transfer correlations presented in the lecture
3. Use Wilson's plots and determine external and internal heat transfer coefficients from given experimental data and specifications of evaporators and condensers

## Introduction:

An evaporator, like condenser is also a heat exchanger. In an evaporator, the refrigerant boils or evaporates and in doing so absorbs heat from the substance being refrigerated. The name evaporator refers to the evaporation process occurring in the heat exchanger.

### 23.1. Classification

There are several ways of classifying the evaporators depending upon the heat transfer process or refrigerant flow or condition of heat transfer surface.

#### 23.1.1. Natural and Forced Convection Type

The evaporator may be classified as *natural convection* type or *forced convection* type. In forced convection type, a fan or a pump is used to circulate



the fluid being refrigerated and make it flow over the heat transfer surface, which is cooled by evaporation of refrigerant. In natural convection type, the fluid being cooled flows due to natural convection currents arising out of density difference caused by temperature difference. The refrigerant boils inside tubes and evaporator is located at the top. The temperature of fluid, which is cooled by it, decreases and its density increases. It moves downwards due to its higher density and the warm fluid rises up to replace it.

### **23.1.2. Refrigerant Flow Inside or Outside Tubes**

The heat transfer phenomenon during boiling inside and outside tubes is very different; hence, evaporators are classified as those with flow inside and outside tubes.

In natural convection type evaporators and some other evaporators, the refrigerant is confined and boils inside the tubes while the fluid being refrigerated flows over the tubes. The direct expansion coil where the air is directly cooled in contact with the tubes cooled by refrigerant boiling inside is an example of forced convection type of evaporator where refrigerant is confined inside the tubes.

In many forced convection type evaporators, the refrigerant is kept in a shell and the fluid being chilled is carried in tubes, which are immersed in refrigerant. Shell and tube type brine and water chillers are mainly of this kind.

### **23.1.3. Flooded and Dry Type**

The third classification is flooded type and dry type. Evaporator is said to be *flooded type* if liquid refrigerant covers the entire heat transfer surface. This type of evaporator uses a float type of expansion valve. An evaporator is called *dry type* when a portion of the evaporator is used for superheating the refrigerant vapour after its evaporation.

## **23.2. Natural Convection type evaporator coils**

These are mainly used in domestic refrigerators and cold storages. When used in cold storages, long lengths of bare or finned pipes are mounted near the ceiling or along the high sidewalls of the cold storages. The refrigerant from expansion valve is fed to these tubes. The liquid refrigerant evaporates inside the tubes and cools the air whose density increases. The high-density air flows downwards through the product in the cold storage. The air becomes warm by the time it reaches the floor as heat is transferred from the product to air. Some free area like a passage is provided for warm air to rise up. The same passage is used for loading and unloading the product into the cold storage.

The advantages of such natural convection coils are that the coil takes no floor space and it also requires low maintenance cost. It can operate for long

periods without defrosting the ice formed on it and it does not require special skill to fabricate it. Defrosting can be done easily (e.g. by scraping) even when the plant is running. These are usually welded at site. However, the disadvantage is that natural convection heat transfer coefficient is very small hence very long lengths are required which may cause excessive refrigerant side pressure drops unless parallel paths are used. The large length requires a larger quantity of refrigerant than the forced convection coils. The large quantity of refrigerant increases the time required for defrosting, since before the defrosting can start all the liquid refrigerant has to be pumped out of the evaporator tubes. The pressure balancing also takes long time if the system trips or is to be restarted after load shedding. Natural convection coils are very useful when low air velocities and minimum dehumidification of the product is required. Household refrigerators, display cases, walk-in-coolers, reach-in refrigerators and obviously large cold storages are few of its applications. Sufficient space should be provided between the evaporator and ceiling to permit the air circulation over the top of the coil. Baffles are provided to separate the warm air and cold air plumes. Single ceiling mounted is used for rooms of width less than 2.5 m. For rooms with larger widths more evaporator coils are used. The refrigerant tubes are made of steel or copper. Steel tubes are used for ammonia and in large capacity systems.

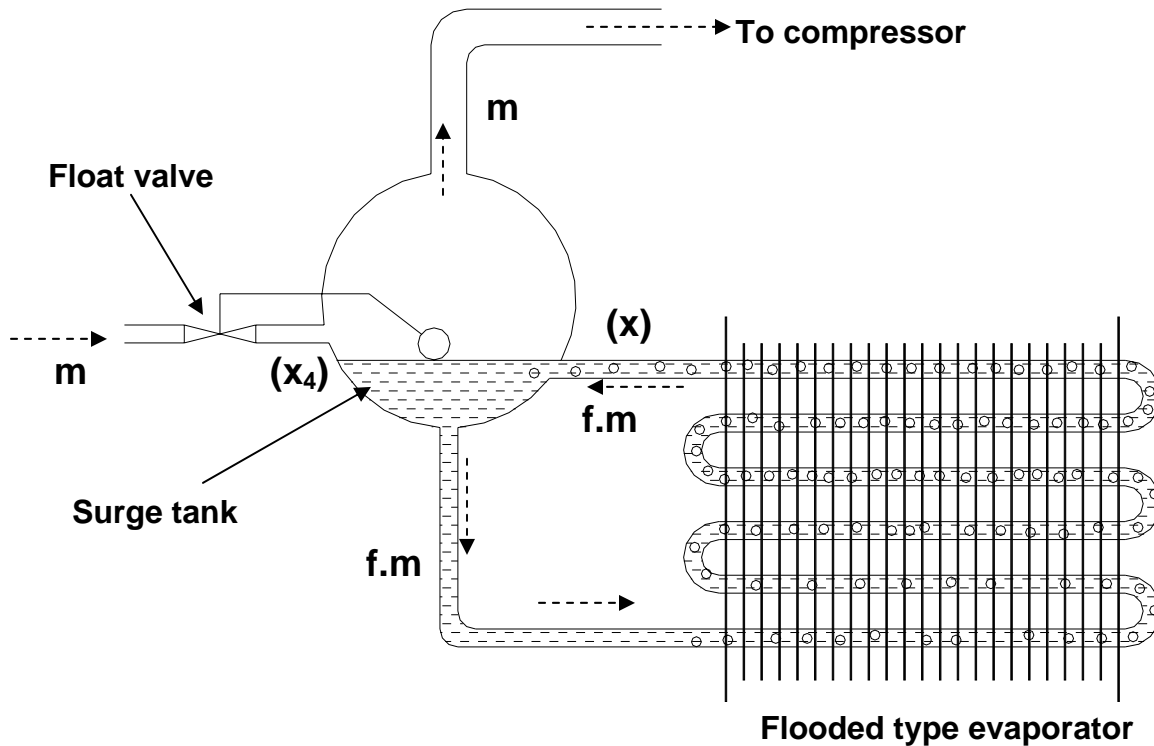
### 23.3.Flooded Evaporator

This is typically used in large ammonia systems. The refrigerant enters a surge drum through a float type expansion valve. The compressor directly draws the flash vapour formed during expansion. This vapour does not take part in refrigeration hence its removal makes the evaporator more compact and pressured drop due to this is also avoided. The liquid refrigerant enters the evaporator from the bottom of the surge drum. This boils inside the tubes as heat is absorbed. The mixture of liquid and vapour bubbles rises up along the evaporator tubes. The vapour is separated as it enters the surge drum. The remaining unevaporated liquid circulates again in the tubes along with the constant supply of liquid refrigerant from the expansion valve. The mass flow rate in the evaporator tubes is  $f \cdot \dot{m}$  where  $\dot{m}$  is the mass flow rate through the expansion valve and to the compressor. The term  $f$  is called recirculation factor. Let  $x_4$  be the quality of mixture after the expansion valve and  $x$  be the quality of mixture after boiling in the tubes as shown in Figure 23.1. In steady state mass flow rate from expansion valve is same as the mass flow rate to the compressor hence mass conservation gives

$$x_4 \cdot \dot{m} + x \cdot f \cdot \dot{m} = \dot{m} \quad (23.1)$$

$$\therefore f = \frac{(1 - x_4)}{x} \quad (23.2)$$

For  $x_4 = x = 0.25$ , for example, the circulation factor is 3, that is mass flow rate through the evaporator is three times that through the compressor. Since, liquid refrigerant is in contact with whole of evaporator surface, the refrigerant side heat transfer coefficient will be very high. Sometimes a liquid refrigerant pump may also be used to further increase the heat transfer coefficient. The lubricating oil tends to accumulate in the flooded evaporator hence an effective oil separator must be used immediately after the compressor.



**Fig.23.1.** Schematic of a flooded evaporator

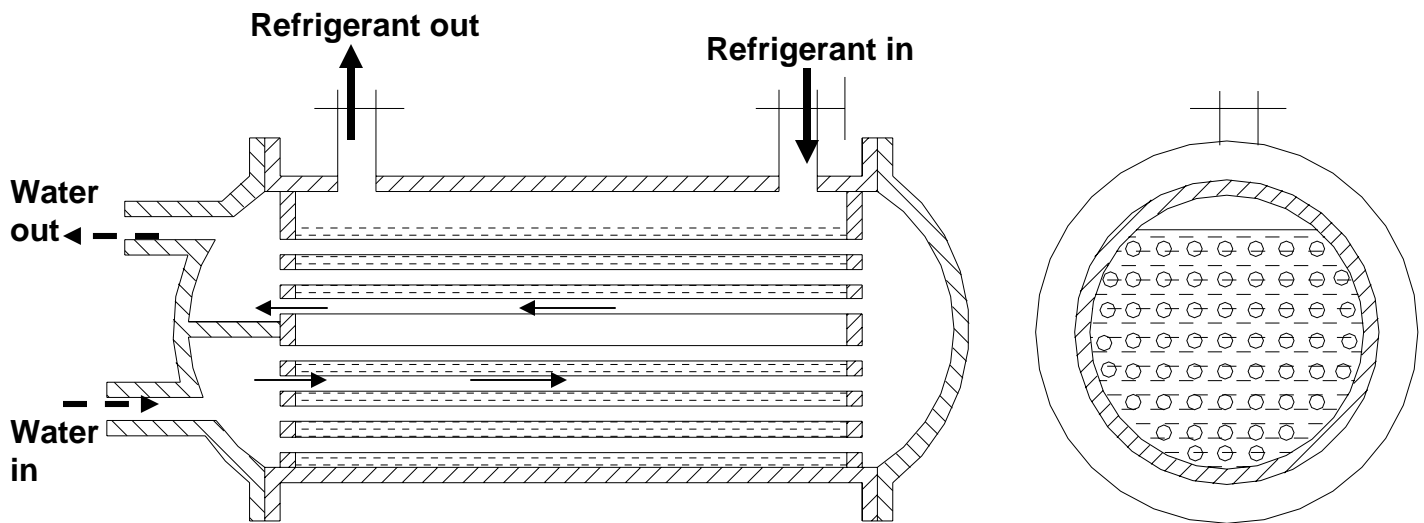
## 23.4. Shell-and-Tube Liquid Chillers

The shell-and-tube type evaporators are very efficient and require minimum floor space and headspace. These are easy to maintain, hence they are very widely used in medium to large capacity refrigeration systems. The shell-and-tube evaporators can be either dry type or flooded type. As the name implies, a shell-and-tube evaporator consists of a shell and a large number of straight tubes arranged parallel to each other. In dry expansion type, the refrigerant flows through the tubes while in flooded type the refrigerant is in the shell. A pump circulates the chilled water or brine. The shell diameters range from 150 mm to 1.5 m. The number of tubes may be less than 50 to several thousands and length may be between 1.5 m to 6 m. Steel tubes are used with ammonia while copper tubes are used with freons. Ammonia has a very high heat transfer coefficient while freons have rather poor heat transfer coefficient hence fins are used on the refrigerant side. Dry expansion type uses fins inside the tubes while flooded type uses fins outside the tube. Dry-expansion type require less charge of refrigerant and have positive lubricating oil return. These are used for small and medium capacity refrigeration plants with capacity ranging from 2 TR to 350 TR. The flooded type evaporators are available in larger capacities ranging from 10 TR to thousands of TR.

### 23.4.1 Flooded Type Shell-and-Tube Evaporator

Figure 23.2 shows a flooded type of shell and tube type liquid chiller where the liquid (usually brine or water) to be chilled flows through the tubes in double pass just like that in shell and tube condenser. The refrigerant is fed through a float valve, which maintains a constant level of liquid refrigerant in the shell. The shell is not filled entirely with tubes as shown in the end view of Fig. 27.2. This is done to maintain liquid refrigerant level below the top of the shell so that liquid droplets settle down due to gravity and are not carried by the vapour leaving the shell. If the shell is completely filled with tubes, then a surge drum is provided after the evaporator to collect the liquid refrigerant.

Shell-and-tube evaporators can be either single pass type or multipass type. In multipass type, the chilled liquid changes direction in the heads. Shell-and-tube evaporators are available in vertical design also. Compared to horizontal type, vertical shell-and-tube type evaporators require less floor area. The chilled water enters from the top and flows downwards due to gravity and is then taken to a pump, which circulates it to the refrigeration load. At the inlet to tubes at the top a special arrangement introduces swirling action to increase the heat transfer coefficient.



**Fig.23.2:** Schematic of a flooded type shell-and-tube evaporator

### 23.4.2. Direct expansion type, Shell-and-Tube Evaporator

Figure 23.3 shows a liquid chiller with refrigerant flowing through the tubes and water flowing through the shell. A thermostatic expansion valve feeds the refrigerant into the tubes through the cover on the left. It may flow in several passes through the dividers in the covers of the shell on either side. The liquid to be chilled flows through the shell around the baffles. The presence of baffles turns the flow around creating some turbulence thereby increasing the heat transfer coefficient. Baffles also prevent the short-circuiting of the fluid flowing in the shell. This evaporator is of dry type since some of the tubes superheat the vapour. To maintain the chilled liquid velocity so as to obtain good heat transfer coefficient, the length and the spacing of segmental baffles is varied. Widely spaced baffles are used when the flow rate is high or the liquid viscosity is high. The number of passes on the refrigerant side are decided by the partitions on the heads on the two sides of the heat exchanger. Some times more than one circuit is also provided. Changing the heads can change the number of passes. It depends upon the chiller load and the refrigerant velocity to be maintained in the heat exchanger.

### 23.5. Shell-and-Coil type evaporator

These are of smaller capacity than the shell and tube chillers. These are made of one or more spiral shaped bare tube coils enclosed in a welded steel shell. It is usually dry-expansion type with the refrigerant flowing in the tube and chilled liquid in the shell. In some cases the chiller operates in flooded mode also with refrigerant in the shell and chilled water flowing thorough the spiral tube. The water in the shell gives a large amount of thermal storage capacity called *hold-up*

capacity. This type is good for small but highly infrequent peak loads. It is used for cooling drinking water in stainless steel tanks to maintain sanitary conditions. It is also used in bakeries and photographic laboratories.

When the refrigerant is in the shell that is in flooded mode it is called instantaneous liquid chiller. This type does not have thermal storage capacity, the liquid must be instantaneously chilled whenever required. In the event of freeze up the water freezes in the tube, which causes bursting of the tubes since water expands upon freezing. When water is in the shell there is enough space for expansion of water if the freezing occurs. The flooded types are not recommended for any application where the temperature of chilled liquid may be below 3°C.

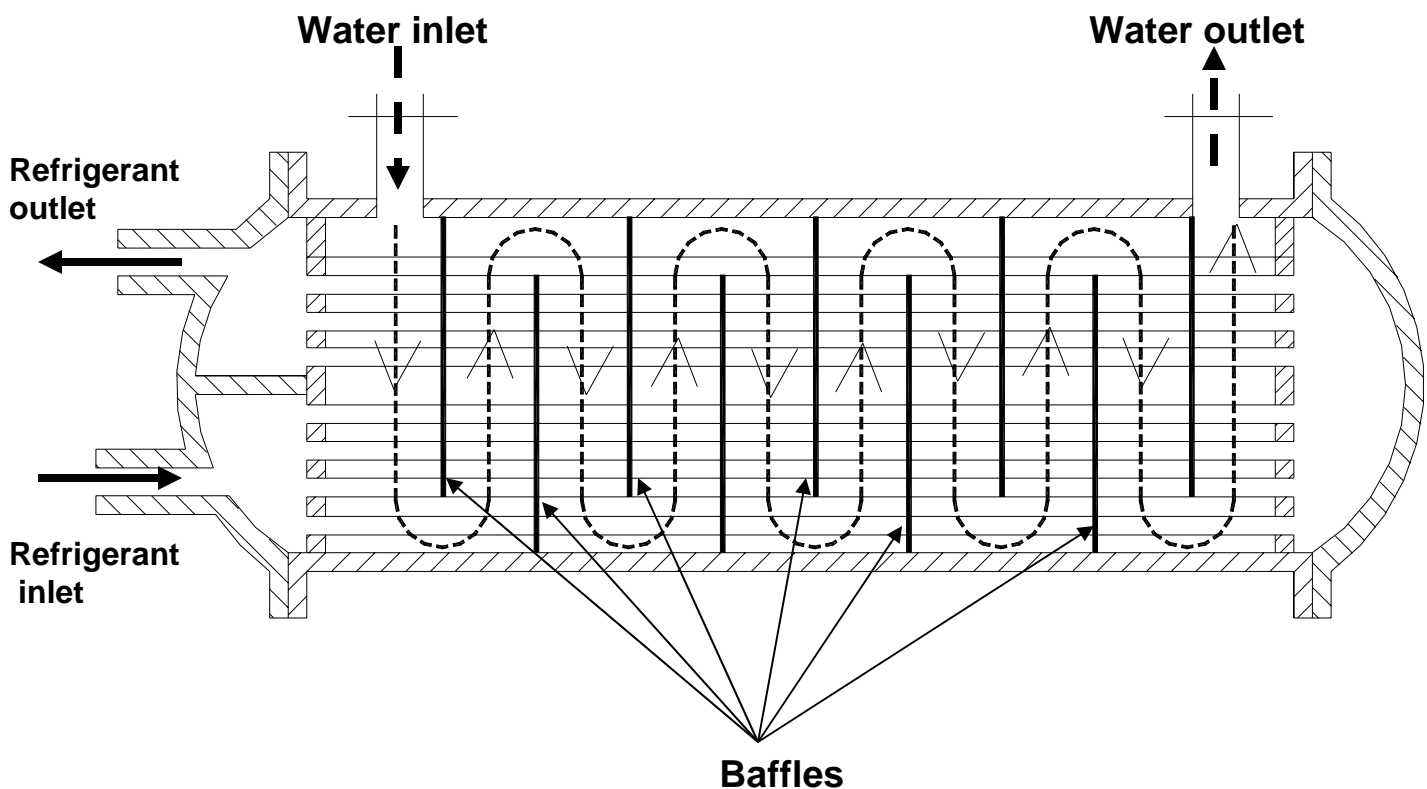
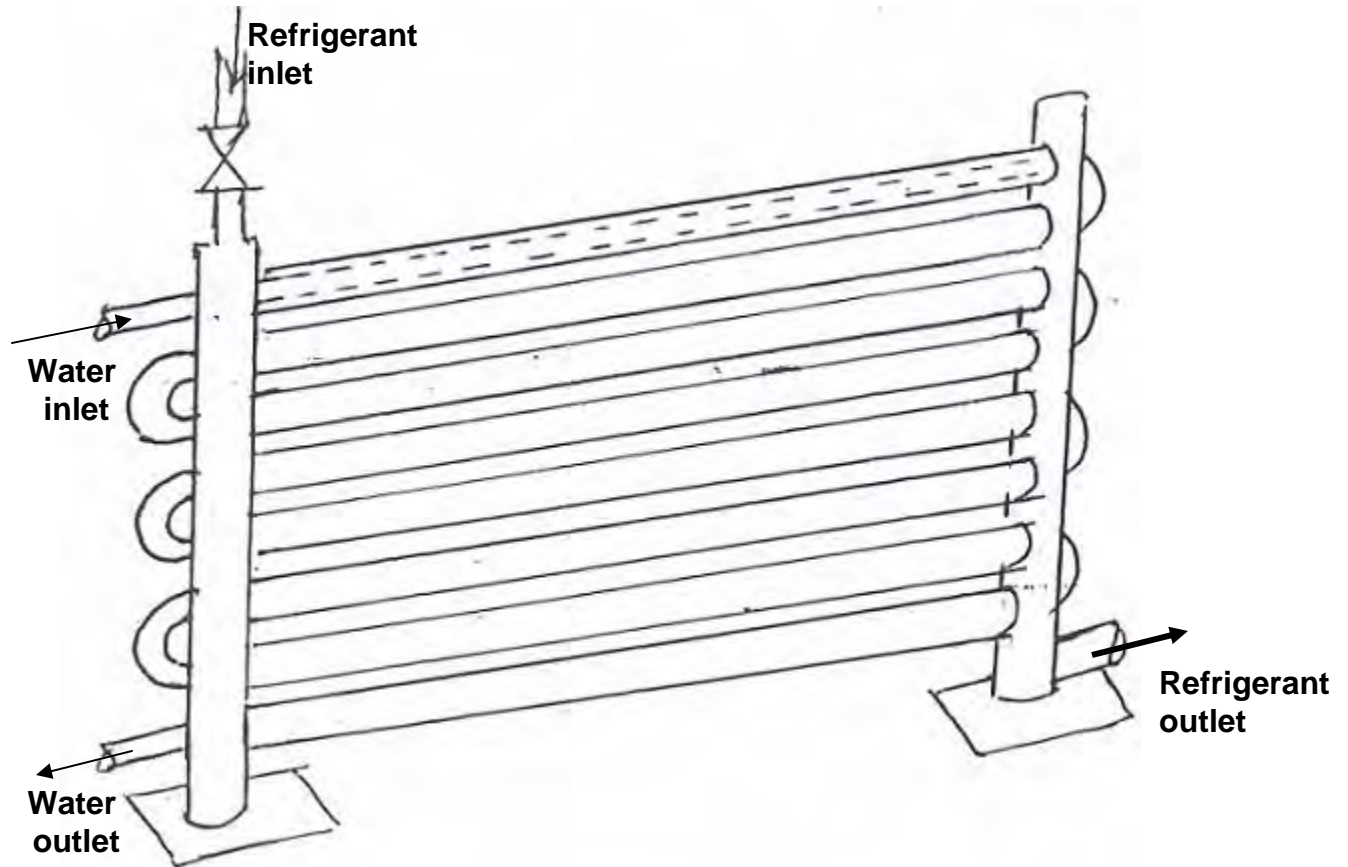


Fig.23.3: Schematic of a direct expansion type, Shell-and-Tube evaporator

## 23.6. Double pipe type evaporator

This consists of two concentric tubes, the refrigerant flows through the annular passage while the liquid being chilled flows through the inner tube in counter flow. One design is shown in Fig. 23.4 in which the outer horizontal tubes are welded to vertical header tubes on either side. The inner tubes pass through the headers and are connected together by 180° bends. The refrigerant side is welded hence there is minimum possibility of leakage of refrigerant. These may

be used in flooded as well as dry mode. This requires more space than other designs. Shorter tubes and counter flow gives good heat transfer coefficient. It has to be insulated from outside since the refrigerant flows in the outer annulus which may be exposed to surroundings if insulation is not provided.

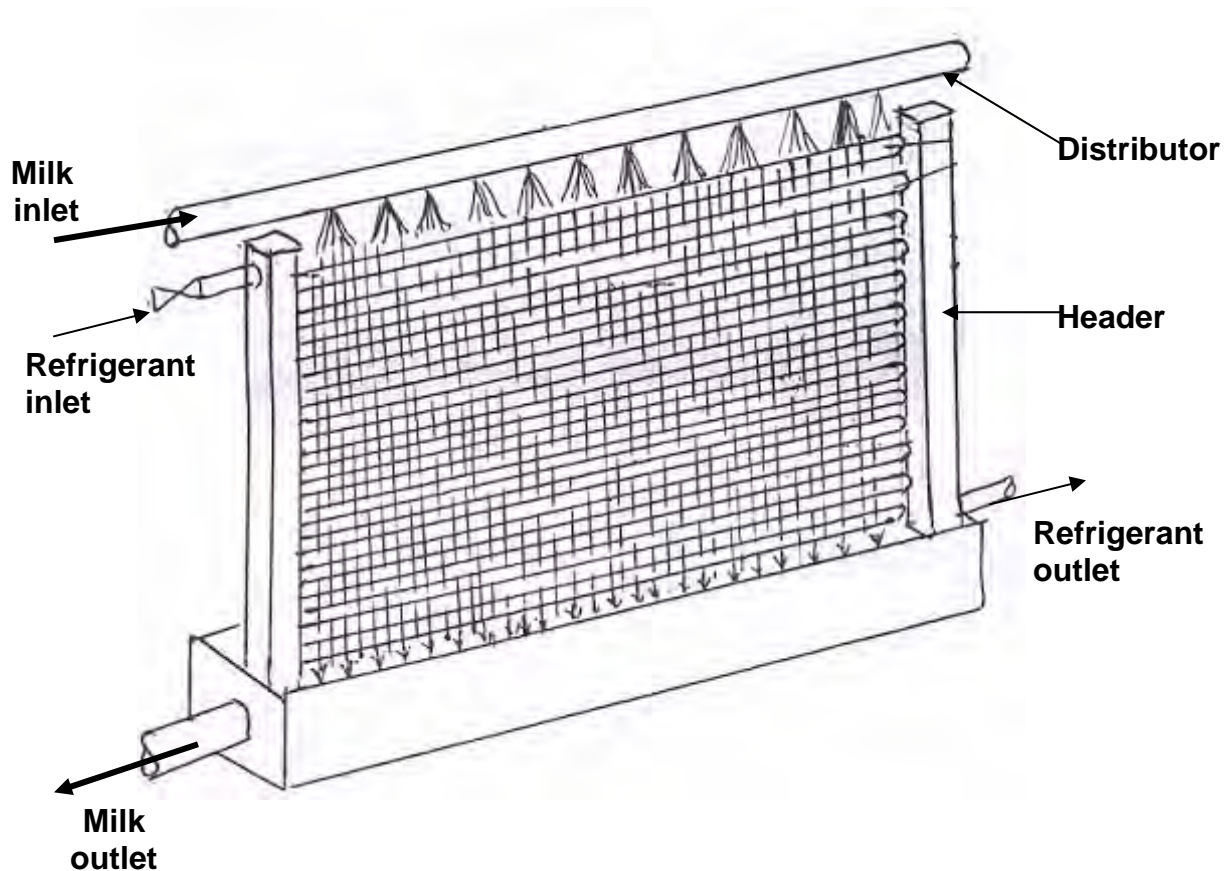


**Fig.23.4:** Schematic of a double pipe type evaporator

### 23.7. Baudelot type evaporators

This type of evaporator consists of a large number of horizontal pipes stacked one on top of other and connected together to by headers to make single or multiple circuits. The refrigerant is circulated inside the tubes either in flooded or dry mode. The liquid to be chilled flows in a thin layer over the outer surface of the tubes. The liquid flows down by gravity from distributor pipe located on top of the horizontal tubes as shown in Figure 23.5. The liquid to be chilled is open to atmosphere, that is, it is at atmospheric pressure and its aeration may take place during cooling. This is widely used for cooling milk, wine and for chilling water for carbonation in bottling plants. The liquid can be chilled very close to its freezing temperature since freezing outside the tubes will not damage the tubes. Another advantage is that the refrigerant circuit can be split into several parts, which

permit a part of the cooling done by cold water and then chilling by the refrigerant.



*Fig.23.5: Schematic of a Baudelot type evaporator for chilling of milk*

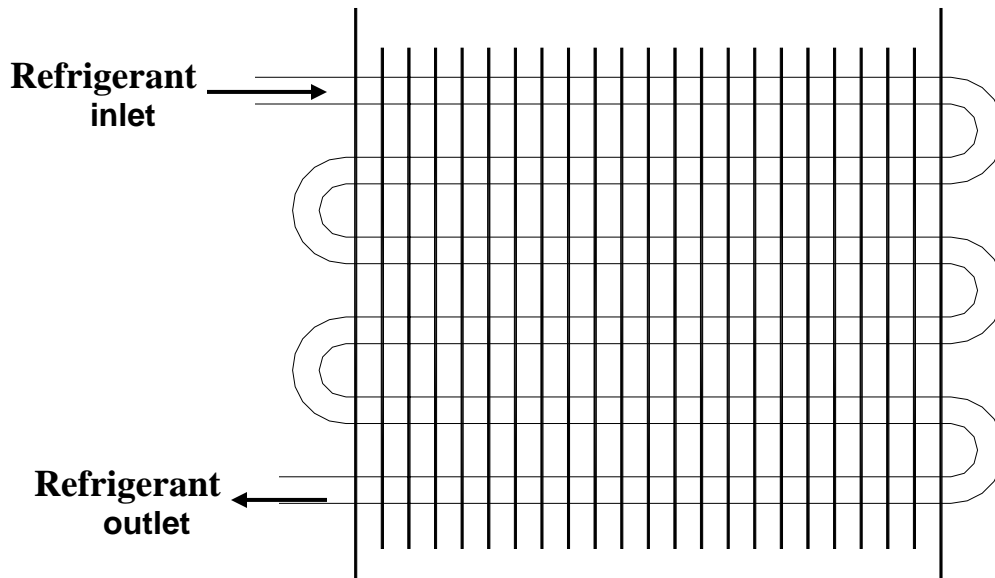
### 23.8. Direct expansion fin-and-tube type

These evaporators are used for cooling and dehumidifying the air directly by the refrigerant flowing in the tubes. Similar to fin-and-tube type condensers, these evaporator consists of coils placed in a number of rows with fins mounted on it to increase the heat transfer area. Various fin arrangements are used. Tubes with individual spiral straight fins or crimped fins welded to it are used in some applications like ammonia. Plate fins accommodating a number of rows are used in air conditioning applications with ammonia as well as synthetic refrigerants such as fluorocarbon based refrigerants.

The liquid refrigerant enters from top through a thermostatic expansion valve as shown in Fig. 23.6. This arrangement makes the oil return to compressor better rather than feeding refrigerant from the bottom of the coil. When evaporator is close to the compressor, a direct expansion coil is used



since the refrigerant lines are short, refrigerant leakage will be less and pressure drop is small. If the air-cooling is required away from the compressor, it is preferable to chill water and pump it to air-cooling coil to reduce the possibility of refrigerant leakage and excessive refrigerant pressure drop, which reduces the COP.



**Fig.23.6:** Schematic of a direct expansion fin-and-tube type

The fin spacing is kept large for larger tubes and small for smaller tubes. 50 to 500 fins per meter length of the tube are used in heat exchangers. In evaporators, the atmospheric water vapour condenses on the fins and tubes when the metal temperature is lower than dew point temperature. On the other hand frost may form on the tubes if the surface temperature is less than  $0^{\circ}\text{C}$ . Hence for low temperature coils a wide spacing with about 80 to 200 fins per m is used to avoid restriction of flow passage due to frost formation. In air-conditioning applications a typical fin spacing of 1.8 mm is used. Addition of fins beyond a certain value will not increase the capacity of evaporator by restricting the airflow. The frost layer has a poor thermal conductivity hence it decreases the overall heat transfer coefficient apart from restricting the flow. Therefore, for applications in freezers below  $0^{\circ}\text{C}$ , frequent defrosting of the evaporator is required.

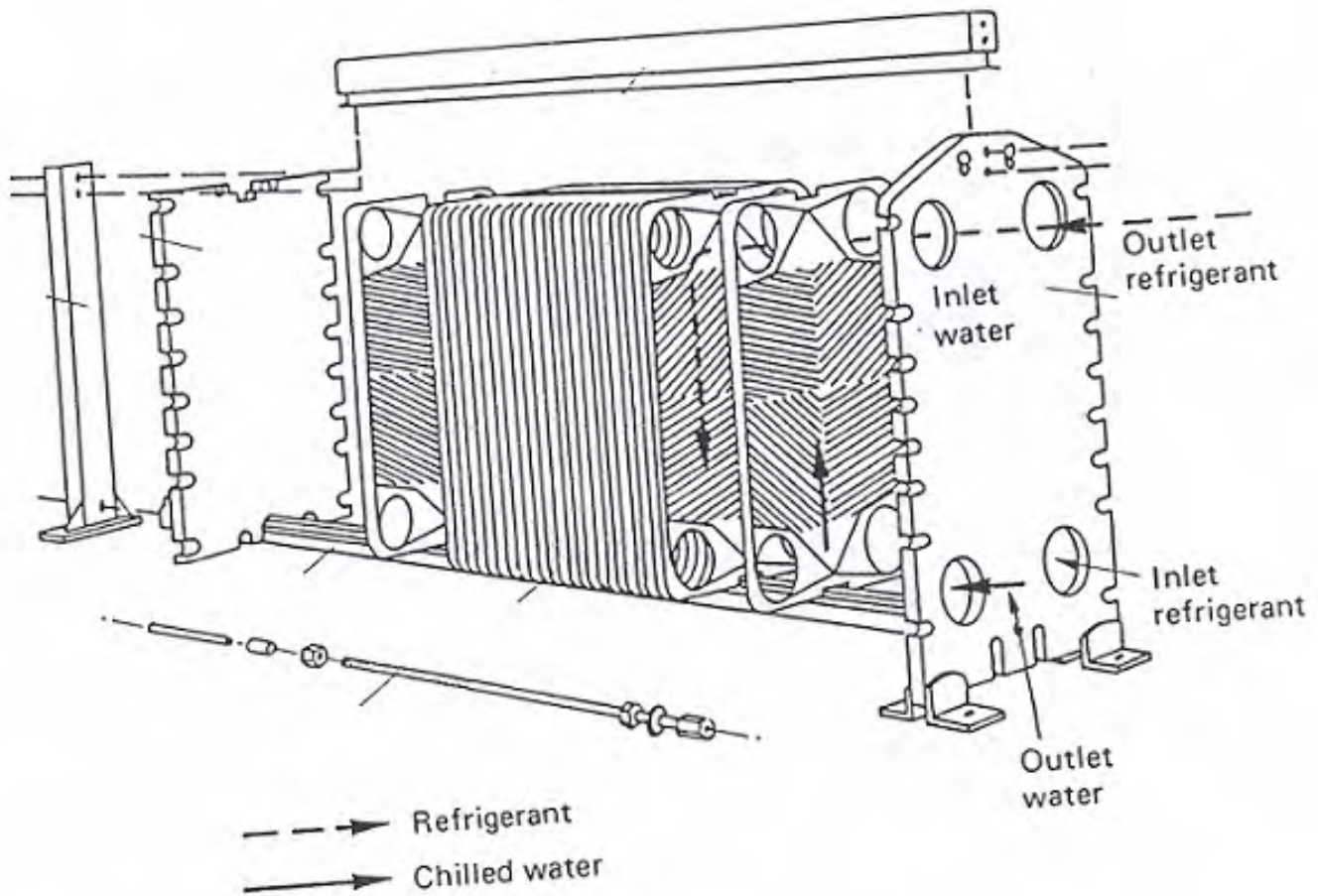
### 23.9. Plate Surface Evaporators

These are also called *bonded plate or roll-bond type evaporators*. Two flat sheets of metal (usually aluminum) are embossed in such a manner that when these are welded together, the embossed portion of the two plates makes a passage for refrigerant to flow. This type is used in household refrigerators. Figure 23.7 shows the schematic of a roll-bond type evaporator.



## 23.10. Plate type evaporators:

Plate type evaporators are used when a close temperature approach (0.5 K or less) between the boiling refrigerant and the fluid being chilled is required. These evaporators are widely used in dairy plants for chilling milk, in breweries for chilling beer. These evaporators consist of a series of plates (normally made of stainless steel) between which alternately the milk or beer to be cooled and refrigerant flow in counterflow direction. The overall heat transfer coefficient of these plate type evaporators is very high (as high as  $4500 \text{ W/m}^2\text{K}$  in case of ammonia/water and  $3000 \text{ W/m}^2\text{K}$  in case of R 22/water). In addition they also require very less refrigerant inventory for the same capacity (about 10 percent or even less than that of shell-and-tube type evaporators). Another important advantage when used in dairy plants and breweries is that, it is very easy to clean the evaporator and assemble it back as and when required. The capacity can be increased or decreased very easily by adding or removing plates. Hence these evaporators are finding widespread use in a variety of applications. Figure 23.9 shows the schematic of a plate type evaporator.



**Fig.23.9:** Schematic of a plate type evaporator

## 23.11. Thermal design of evaporators:

Compared to the design of refrigerant condensers, the design of refrigerant evaporators is more complex. The complexity arises due to the following factors:

- a) On the refrigerant side, the heat transfer coefficient varies widely when evaporation takes place in tubes due to changing flow regimes. Accurate estimation of heat transfer coefficient is thus difficult
- b) On the external fluid side, if the external fluid is air (as in air conditioning and cold storage applications), in addition to sensible heat transfer, latent heat transfer also takes place as moisture in air may condense or even freeze on the evaporator surface. The evaporator surface may be partly dry and partly wet, depending upon the operating conditions. Hence, mass transfer has to be considered in the design. If frost formation due to freezing of moisture takes place, then heat transfer resistance varies continuously with time.
- c) The lubricating oil gets separated in the evaporator tubes due to low miscibility of oil at evaporator temperature and pressure. The separation of oil affects both heat transfer and pressure drop characteristics. A minimum refrigerant velocity must be provided for oil carry over in direct expansion type evaporators.
- d) Compared to condenser, refrigerant pressure drop in evaporator is more critical as it has significant influence on the performance of the refrigeration system. Hence, multiple circuits may have to be used in large systems to reduce pressure drops. Refrigerant velocity has to be optimized taking pressure drop and oil return characteristics into account.
- e) Under part-load applications, there is a possibility of evaporator flooding and compressor slugging. This aspect has to be considered at the time of evaporator design.

### **Estimation of heat transfer area and overall heat transfer coefficients**

For plate fin type evaporators, the expressions of various heat transfer areas are similar to those given for the air-cooled condensers. The expression for overall heat transfer coefficient is also similar to that of condenser as long as no phase change (e.g. moisture condensation or freezing) takes place. However, as mentioned in air-cooled evaporators the possibility of moisture condensing/freezing on the evaporator surface must be considered unlike in condensers where the heat transfer on airside is only sensible. This requires simultaneous solution of heat and mass transfer equations on the airside to arrive at expressions for overall heat transfer coefficient and mean temperature difference. The efficiency of the fins will also be affected by the presence of condensed layer of water or a frozen layer of ice. Expressions have been derived for overall heat transfer coefficient, mean temperature difference and fin efficiency of fin-and-tube type evaporators in which air undergoes cooling and

dehumidification. The analysis of cooling and dehumidification coils requires knowledge of psychrometry and is obviously much more complicated compared to evaporators in which the external fluid does not undergo phase change. In this lecture, only the evaporators wherein the external fluid does not undergo any phase change are considered. Readers should refer to advanced books on refrigeration for the design aspects of cooling and dehumidifying coils.

### **Estimation of heat transfer coefficients:**

#### **a) Air side heat transfer coefficients in fin-and-tube type evaporators:**

If air undergoes only sensible cooling as it flows over the evaporator surface (i.e., dry evaporator), then the correlations presented for air cooled condensers for heat transfer coefficients on finned (e.g. Kays & London correlation) and bare tube surface (e.g. Grimson's correlation) can be used for air cooled evaporator also. However, if air undergoes cooling and dehumidification, then analysis will be different and correlations will also be different. These aspects will be discussed in a later chapter.

#### **b) Liquid side heat transfer coefficients:**

##### **Liquid flowing in tubes:**

When liquids such as water, brine, milk etc. flow through tubes without undergoing any phase changes, the correlations presented earlier for condensers (e.g. *Dittus-Boelter*, *Sieder-Tate*) can be used for evaporator also.

##### **Liquid flowing in a shell:**

In direct expansion type, shell-and-tube evaporators refrigerant flows through the tubes, while water or other liquids flow through the shell. Analytical prediction of single phase heat transfer coefficient on shell side is very complex due to the complex fluid flow pattern in the presence of tubes and baffles. The heat transfer coefficient and pressure drop depends not only on the fluid flow rate and its properties, but also on the arrangement of tubes and baffles in the shell. Several correlations have been suggested to estimate heat transfer coefficients and pressure drops on shell side. A typical correlation suggested by Emerson is given below:

$$\text{Nu} = \frac{hd}{k_f} = C \text{Re}_d^{0.6} \text{Pr}^{0.3} \left( \frac{\mu}{\mu_w} \right)^{0.14} \quad (23.3)$$

where constant C depends on the geometry, i.e, on the arrangement of the tubes, baffles etc.

In the above expression the Reynolds number  $Re_d$  is defined as:

$$Re_d = \frac{Gd}{\mu} \quad (23.4)$$

where  $G$  is the mass velocity which is equal to the mass flow rate divided by the characteristic flow area ( $\text{kg/m}^2\cdot\text{s}$ ). From the expression for Nusselt number, it can be seen that the heat transfer coefficient is proportional to the 0.6 power of the flow rate as compared to 0.8 power for flow through tubes.

The pressure drop of liquid flowing through the shell is also difficult to predict analytically. Normally the pressure drop on shell side is obtained from experimental measurements and is provided in the form of tables and charts for a particular type of shell-and-tube heat exchanger.

### c) Boiling Heat Transfer Coefficients:

#### Pool boiling vs flow boiling:

In evaporators boiling of refrigerant may take place outside tubes or inside tubes. When boiling takes place outside the tubes it is called as pool boiling. In pool boiling it is assumed that the tube or the heat transfer surface is immersed in a pool of liquid, which is at its saturation temperature. Figure 23.10 shows a typical boiling curve, which shows the variation of surface heat flux with temperature difference between the surface and the saturation temperature for different regimes. For a small temperature difference, the heat transfer from the surface is by free convection (regime 1). As the temperature difference increases, bubbles start to form at selected nucleation sites. The bubbles grow in size as heat is transferred and the evaporation of liquid occurs. After achieving a critical diameter depending upon the surface tension and other factors, the bubbles get detached from the surface and rise to the free surface where the vapour inside the bubbles is released. During the detachment process, the surrounding liquid rushes towards the void created and also during the bubble motion upwards convection heat transfer increases from its free convection value at smaller temperature differences. This region is known as *individual bubble regime* (regime 2). As the temperature difference increase further, more and more bubbles are formed and it is the columns of bubbles, which rise up increasing the heat transfer drastically. This regime is known as *column bubble regime* (regime 3).

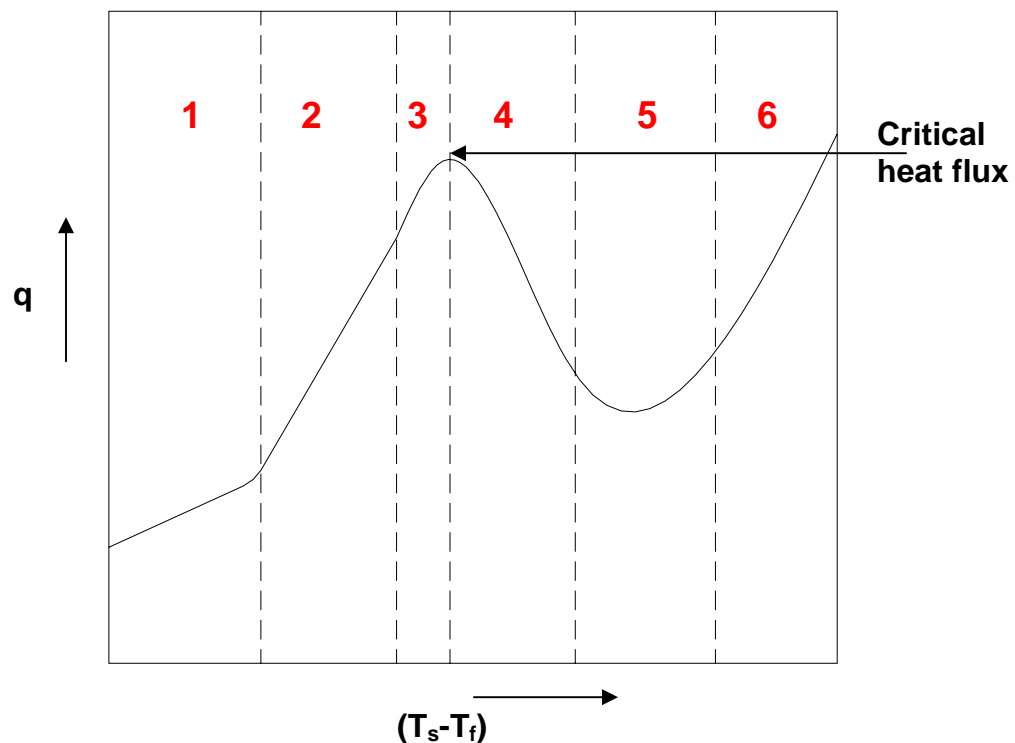
As the temperature difference increases further, more and more bubbles are formed, and columns of bubbles rise to the free surface. The heat transfer rate increases rapidly. As the bubble columns move upwards they entrain some liquid also that rises upwards to the free surface. The vapour in the bubbles escapes at the free surface but the liquid returns to the bottom because of its lower temperature and higher density. A given surface can accommodate only a few such rising columns of bubbles and descending columns of relatively colder

liquid. Hence, the heat transfer rate cannot increase beyond a certain value. It becomes maximum at some temperature difference. The maximum heat transfer rate is called *critical heat transfer rate*.

If temperature difference is increased beyond this value, then a blanket of film forms around the heat transfer surface. This vapour film offers conduction thermal resistance; as a result the heat transfer rate decreases. The film however is unstable and may break at times. This regime is called *unstable film regime (regime 4)*.

If temperature difference is increased further it becomes so high that radiation heat transfer becomes very important and heat transfer rate increases because of radiation component. This regime is called *stable film boiling regime (regime 5)*. After this, due to the high surface temperature, radiation effects become important (*regime 6*).

As the temperature difference is increased, the temperature of the surface  $t_w$  continues to increase since conduction thermal resistance of the film becomes larger as the film thickness increases. All the heat from the surface cannot be transferred across the film and surface temperature increases. Ultimately the temperature may approach the melting point of the metal and severe accident may occur (if these are the tubes of nuclear power plant). This point is referred to as burnout point.



**Fig.23.10:** A typical pool boiling curve showing different regimes, 1 to 6

Boiling inside tubes is called as flow boiling. Flow boiling consists of nucleate boiling as well as convective heat transfer. As the liquid evaporates, more vapour is formed which increases the average velocity and the convective heat transfer rate. The flow pattern changes continuously as boiling takes place along the tube. For example in a horizontal tube, the flow can be stratified flow, wavy flow, slug flow, annular flow, mist flow etc. The flow pattern will be different if it takes place in an inclined or vertical tube. The heat transfer coefficient depends upon fraction of vapour present and parameters of forced convection heat transfer. In general, prediction of boiling heat transfer coefficients during flow boiling is much more complex than pool boiling. However, a large number of empirical correlations have been developed over the years to predict boiling heat transfer coefficients for both pool as well as flow boiling conditions. The following are some of the well-known correlations:

### Nucleate Pool Boiling

Normally evaporators are designed to operate in nucleate pool boiling regime as the heat transfer coefficients obtained in this regime are stable and are very high. Various studies show that in nucleate pool boiling region, the heat transfer coefficient is proportional to the 2 or 3 power of temperature difference between the surface and the boiling fluid, i.e.,

$$h_{nb} = C(T_s - T_f)^{2 \text{ to } 3} \quad (23.5)$$

the value of C depends upon type of the surface etc. The exponent can be as high as 25 on specially treated surfaces for enhancement of boiling.

**Rohsenow's Correlation for nucleate pool boiling:** This correlation is applicable to clean surfaces and is relatively independent of shape and orientation of the surface.

$$\frac{C_f \Delta T_x}{h_{fg}} = C_{sf} \left[ \frac{Q/A}{\mu_f h_{fg}} \sqrt{\frac{\sigma}{g(\rho_f - \rho_g)}} \right]^{0.33} Pr_f^s \quad (23.6)$$

where:

$C_f$  = Specific heat of liquid

$\Delta T_x$  = Temperature difference between surface and fluid

$h_{fg}$  = Latent heat of vaporization

$\sigma$  = Surface Tension

$C_{sf}$  = constant which depends on the surface-fluid combination, e.g. 0.013 for halocarbons boiling on copper surface

$Q/A$  = heat flux

$\mu_f$  = Viscosity of fluid

$\rho_f, \rho_g$  = Density of saturated liquid and saturated vapour, respectively

$Pr_f$  = Prandtl number of saturated liquid

$s$  = constant, 1 for water and 1.7 for halocarbons



All the fluid properties are calculated at saturation temperature corresponding to the local pressure.

### Forced Convection Boiling inside tubes:

Rohsenow and Griffith suggested that flow boiling in tubes be analyzed as a combination of pool boiling and forced convection. The total heat flux ( $q_{total}$ ) is the sum of heat flux due to nucleate pool boiling ( $q_{nb}$ ) and forced convection ( $q_{fc}$ ), i.e.,

$$q_{total} = q_{nb} + q_{fc} \quad (23.7)$$

Heat flux due to nucleate pool boiling ( $q_{nb}$ ) is calculated by using nucleate pool boiling correlations and heat flux due to forced convection ( $q_{fc}$ ) can be calculated by using standard forced convection correlations, such as Dittus-Boelter correlation.

Some of the other correlations suggested for flow boiling are given below:

(a) Bo Pierre's Correlation : This correlation gives average heat transfer coefficients and is valid for inlet quality  $x_{inlet} \approx 0.1$  to 0.16.

$$\bar{Nu}_f = 0.0009 \left( Re_f^2 K_f \right)^{1/2} \quad \text{: for incomplete evaporation and } x_{exit} < 0.9$$

$$\bar{Nu}_f = 0.0082 \left( Re_f^2 K_f \right)^{1/2} \quad \text{: for complete evaporation} \quad (23.8)$$

In the above equations,  $Re_f$  and  $Nu_f$  are liquid Reynolds and Nusselt numbers, respectively.  $K_f$  is the load factor, defined as:

$$K_f = \frac{\Delta x h_{fg}}{L} \quad (23.9)$$

where  $L$  is the length of the tube.

(b) Chaddock-Brunemann's Correlation:

$$h_{TP} = 1.91 h_L \left[ Bo \cdot 10^4 + 1.5 (1/x_{tt})^{0.67} \right]^{0.6} \quad (23.10)$$

$$Bo = \text{Boiling Number} = \frac{Q/A}{h_{fg} (\dot{m}/A)}$$

$$x_{tt} = \left( \frac{1-x}{x} \right)^{0.9} (\rho_g / \rho_f)^{0.5} (\mu_f / \mu_g)^{0.1} \quad \text{Lockhart - Martinelli Parameter}$$

(c) Jung and Radermacher Correlation:

$$h_{TP} = N_1 h_{sa} + F_1 h_L \quad (23.11)$$

where  $h_L$  is the single phase (liquid) heat transfer coefficient as predicted by Dittus-Boelter equation, and  $h_{sa}$  is given by:

$$h_{sa} = 207 \frac{k_f}{bd} \left( \frac{q}{k_f} \cdot \frac{bd}{T_{sat}} \right)^{0.745} \left( \frac{\rho_g}{\rho_f} \right)^{0.581} Pr_f^{0.533}$$

$$bd = 0.0146 \beta \left[ \frac{2\sigma}{g(\rho_f - \rho_g)} \right]^{-0.5} \quad : \beta = 35^\circ \quad (23.12)$$

$$N_1 = 4048 X_{tt}^{1.22} Bo^{1.13} \quad : \text{for } X_{tt} \leq 1$$

$$N_1 = 2.0 - 0.1 X_{tt}^{-0.28} Bo^{-0.33} \quad : \text{for } 1 < X_{tt} \leq 5$$

$$F_1 = 2.37 (0.29 + 1/X_{tt})^{0.85}$$

In nucleate boiling, the heat transfer coefficient is mainly dependent on the heat flux and is a very weak function of mass flux. However, in flow boiling the heat transfer coefficient depends mainly on mass flux and is a weak function of heat flux. Studies show that for boiling inside tubes, initially when the vapour fraction (quality) is low, then nucleate boiling is dominant and the heat transfer coefficient depends on heat flux. However, as the fluid flows through the tubes, the vapour fraction increases progressively due to heat transfer and when it exceeds a critical vapour fraction, convective boiling becomes dominant. As mentioned, in this region, the heat transfer coefficient depends mainly on the mass flux and is almost independent of heat flux. As a whole, the heat transfer coefficient due to boiling initially reaches a peak and then drops towards the end of the tube. Thus accurate modeling of evaporators requires estimation of heat transfer coefficient along the length taking into account the complex physics.

Horizontal vs Vertical tubes: As mentioned before, boiling heat transfer coefficients in vertical columns will be different from that in a horizontal tube. In a vertical tube, due to hydrostatic head, the evaporation temperature increases, which in turn reduces the driving temperature difference, and hence, the heat transfer rate.

Effect of oil in evaporator: Studies on R 12 evaporators show that the boiling heat transfer coefficient inside tubes increases initially with oil concentration upto a value of about 4 percent and then decreases. The initial increase is attributed to the greater wetting of the tube surface due to the presence of oil. The subsequent reduction is due to the rapid increase in viscosity of the refrigerant-oil mixture as oil is more viscous than refrigerant. For the estimation of heat transfer

coefficient, the presence of oil may be neglected as long as its concentration is low (less than 10 percent).

### 23.12. Enhancement of heat transfer coefficients:

The overall heat transfer coefficient of a heat exchanger depends mainly on the component having the largest resistance to heat transfer. When air is used as an external fluid, the heat transfer coefficient on air side is small, hence to obtain high overall heat transfer coefficient, the air side heat transfer is augmented by adding fins. When liquid water is used as the external fluid, then the heat transfer coefficient on water side will be high, when the flow is turbulent (which normally is the case). Hence to further improve overall heat transfer coefficient, it may become necessary to enhance heat transfer on the refrigerant side. This is especially the case with synthetic refrigerants. The enhancement of boiling heat transfer coefficient can be achieved in several ways such as: increasing the refrigerant velocity by using an external pump in flooded evaporators, by using integrally finned tubes, by using treated surfaces, by using turbulence promoters etc. These methods improve the refrigerant side heat transfer coefficient and hence the overall heat transfer coefficient significantly leading to compact and lightweight evaporators. However, it should be kept in mind that normally any heat transfer enhancement technique imposes penalty by means of increased pressure drop, hence it is essential to optimize the design so that the total cost is minimized.

### 23.13. Wilson's plot:

The concept of Wilson's plot was introduced way back in 1915 by Wilson to determine individual heat transfer coefficients from the experimental data on heat transfer characteristics of heat exchangers. This is sometimes applied to determine the condensing or boiling heat transfer coefficients of condensers and evaporators respectively.

For example, in a water-cooled condenser a number of tests are conducted by varying the flow rate of water and measuring the inlet and outlet water temperatures. The total heat transfer rate is determined from

$$Q = \dot{m}_w C_{pw} (t_{wo} - t_{wi}) = U_o A_o (\text{LMTD}) \quad (23.13)$$

From measured temperatures, LMTD is calculated. From the heat transfer rate  $Q$ , area of the heat exchanger ( $A_o$ ) and LMTD, the overall heat transfer coefficient for a given flow rate is calculated using Eqn.(23.13).

Then the overall heat transfer coefficient  $U_o$  is equated to the following equation (for clean tubes are clean with negligible scale formation)

$$\frac{1}{U_o} = \frac{A_o}{h_i A_i} + \frac{A_o r_i \ln(d_o/d_i)}{A_i k_w} + \frac{1}{h_o} \quad (23.14)$$

If the water temperature does not vary very significantly during these tests, then properties of water remain nearly constant. Since during these tests no changes are made on the refrigerant side, it can be assumed that the heat transfer resistance offered by the wall separating the two fluids and the heat transfer coefficient on refrigerant side ( $h_o$ ) remains constant for all values of water flow rates. Hence, the above equation can be written as:

$$\frac{1}{U_o} = C_1 + \frac{C_2}{h_i} \quad (23.15)$$

where  $C_1$  and  $C_2$  are empirical constants that depend on the specifications of the heat exchangers and operating conditions, and the expressions for these can be obtained by equating Eqns.(23.14) and (23.15).

If flow on water side is turbulent and the variation in thermal properties are negligible, then the waterside heat transfer coefficient can be written as:

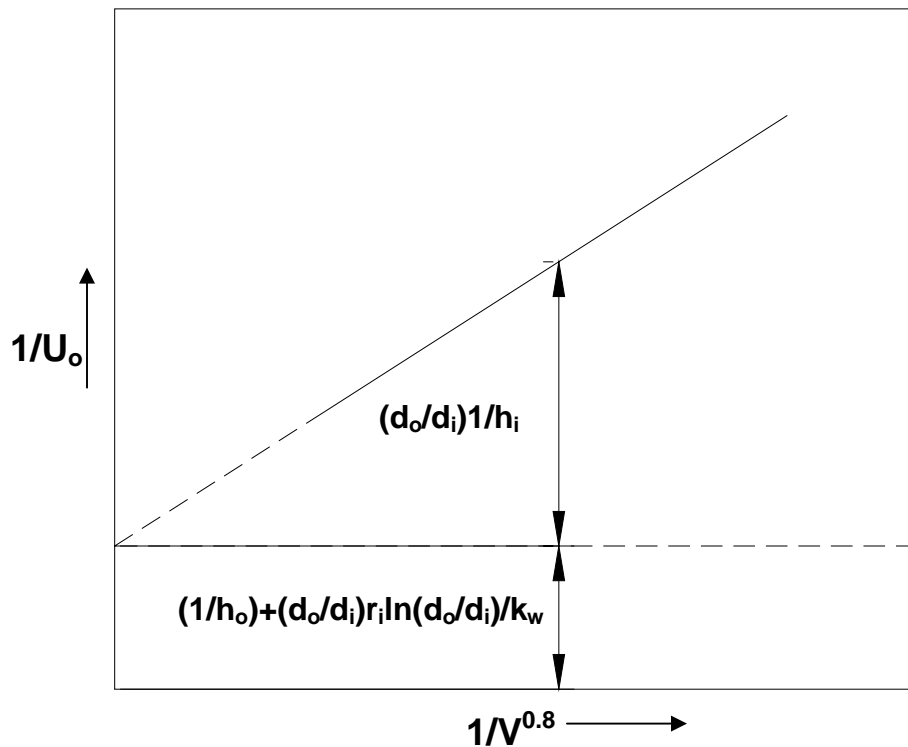
$$h_i = C_3 \cdot V^{0.8} \quad (23.16)$$

Substituting the expression in Eqn.(23.15), we obtain:

$$\frac{1}{U_o} = C_1 + \frac{C_4}{V^{0.8}} \quad (23.17)$$

Then a plot of  $1/U_o$  vs  $1/V^{0.8}$  will be a straight line as shown in Fig. 23.11. This plot is extrapolated to infinitely high velocity, i.e., where  $1/V^{0.8}$  tends to zero. When  $1/V^{0.8}$  tends to zero, from Eqn.(23.16)  $1/h_i$  also tends to zero. Hence, the intercept on the ordinate is  $C_1 (=1/h_o + A_o r_i \ln(d_o/d_i)/(A_i k_w))$ . The thermal conduction resistance of the tube can be calculated and then the condensation heat transfer coefficient  $h_o$  can be calculated. As shown in the figure the term  $A_o/(A_i h_i)$  can also be obtained from the figure at any value of velocity.

It should be kept in mind that it is an approximation since drawing a straight line and extending it to meet y-axis means that condensation heat transfer remains constant as the velocity tends to infinity. Wilson plot can be applied to air-cooled condensers also. In this case as the heat transfer coefficient for air over finned surface varies as  $V^{0.65}$ , hence in this case  $1/U_o$  will have to be plotted versus  $V^{-0.65}$ .



**Fig.23.11:** Concept of Wilson's plot

### Questions and answers:

1. Which of the following statements are TRUE?

- a) In conventional refrigerators, the evaporators are kept at the top as these are natural convection type
- b) Natural convection type coils are useful when the latent loads are very high
- c) Defrosting of evaporators has to be done more frequently in natural convection type coils compared to forced convection evaporator coils
- d) Provision of sufficient free space is very important in natural convection type evaporator coils

**Ans.: a) and d)**

2. Which of the following statements are TRUE?

- a) Flooded type evaporators are very efficient as the heat transfer coefficient on refrigerant side is very large
- b) In flooded type evaporators, the refrigerant evaporation rate is equal to the refrigerant mass flow rate
- c) An oil separator is always required in flooded evaporators as refrigerant tends to get collected in the evaporator
- d) All of the above

**Ans.: a) and c)**

3. Which of the following statements are TRUE?

- a) Shell-and-tube evaporators are available in small to very large capacities
- b) In dry expansion type evaporator, refrigerant flows through the shell while the external fluid flows through the tubes
- c) Normally float valves are used expansion devices for flooded type evaporators
- d) In shell-and-coil type evaporators, thermal storage can be obtained by having refrigerant on the shell side

**Ans.: a) and c)**

4. Which of the following statements are TRUE?

- a) In direct expansion, fin-and-tube type evaporators, the oil return to compressor is better if refrigerant enters at the bottom of the evaporator and leaves from the top
- b) For low temperature applications, the fin spacing of evaporator is kept larger to take care of the frost formation
- c) Double pipe type evaporators are used when close temperature approach is required
- d) Plate type evaporators are used when close temperature approach is required

**Ans.: b) and d)**

5. Thermal design of evaporators is very complex due to:

- a) Continuous variation of heat transfer coefficient along the length
- b) Possibility of latent heat transfer on the external fluid side also
- c) Presence of lubricating oil affects heat transfer and pressure drop
- d) All of the above

**Ans.: d)**

6. Which of the following statements are TRUE?

- a) In evaporators using air as an external fluid, fins are frequently required on the refrigerant side
- b) In evaporators using water as an external fluid, fins may be required on the refrigerant side to enhance heat transfer
- c) Flooded type evaporators yield higher heat transfer coefficients compared to direct expansion type evaporators
- d) In general heat transfer enhancement techniques yield more compact heat exchangers, but may also increase pressure drop

**Ans.: b), c) and d)**

7. Air enters a direct expansion type, fin-and-tube evaporator at a temperature of 17°C and leaves the evaporator at 11°C. The evaporator operates at a constant temperature of 7°C and has total refrigerant side area of 12 m<sup>2</sup>, while the bare tube and finned areas on airside are 10 m<sup>2</sup> and 212 m<sup>2</sup>, respectively. Find the refrigeration capacity of the evaporator assuming only sensible heat transfer on airside and counterflow type arrangement. Neglect fouling and resistance offered by the tube wall. The fin effectiveness for airside is 0.75. The average heat transfer coefficient on refrigerant and airside are 1700 W/m<sup>2</sup>.K and 34 W/m<sup>2</sup>.K, respectively.

Ans.: Neglecting fouling and resistance of the tube wall, the value of 'UA' of evaporator is given by:

$$\frac{1}{UA} = \frac{1}{[h(A_f \eta_f + A_b)]_o} + \frac{1}{h_i A_i}$$

Substituting the values of airside and refrigerant heat transfer coefficients ( $h_o$  and  $h_i$ ), bare tube ( $A_b$ ), finned surface ( $A_f$ ) and refrigerant side areas and fin efficiency ( $\eta_f = 0.75$ ) in the above expression, we obtain:

$$UA = 4483 \text{ W/K}$$

From the values of airside and evaporator temperatures, the LMTD of the evaporator is given by:

$$LMTD = \frac{(17 - 11)}{\ln\left(\frac{17 - 7}{11 - 7}\right)} = 6.55^\circ \text{C}$$

Hence, refrigeration capacity,  $Q_e = UA.LMTD = 29364 \text{ W} = 29.364 \text{ kW}$  (Ans.)

8. The following are the values measured on a shell-and-tube ammonia condenser:

Velocity of water flowing through the tubes, V (m/s)	1.22	0.61
Overall heat transfer coefficient, $U_o$ ( $W/m^2.K$ )	2300	1570

Water flowed inside the tubes while refrigerant condensed outside the tubes. The tubes were 51 mm OD and 46 mm ID and had a conductivity of 60 W/m.K. Using the concept of Wilson's plot, determine the condensing heat transfer coefficient. What is the value of overall heat transfer coefficient when the velocity of water is 0.244 m/s?

Ans.:

From the data given in the table, the following straight line equation can be obtained:

$$\frac{1}{U_o} = C_1 + \frac{C_4}{V^{0.8}}$$

The values of  $C_1$  and  $C_4$  for the given data are found to be:

$$C_1 = 1.605 \times 10^{-4} \text{ m}^2.K/W \text{ and } C_4 = 3.223 \times 10^{-4} \text{ m}^{1.2}.K/W$$

The constant  $C_1$  is equal to:

$$C_1 = \frac{r_o \ln(r_o / r_i)}{k_w} + \frac{1}{h_o} = 1.605 \times 10^{-4}$$

Substituting the values of internal and external radii ( $r_i$  and  $r_o$ ) and the value of thermal conductivity of the tube  $k_w$ , we obtain the value of external heat transfer coefficient (condensation heat transfer coefficient,  $h_o$ ) as:

$$h_o = 8572.9 \text{ W/m}^2.K \quad (\text{Ans.})$$

The value of overall heat transfer coefficient  $U_o$  when the velocity of water is 0.244 m/s is given by:

$$\frac{1}{U_o} = C_1 + \frac{C_4}{V^{0.8}} = 1.605 \times 10^{-4} + \frac{3.223 \times 10^{-4}}{0.244^{0.8}} = 1.1567 \times 10^{-3}$$

$$\Rightarrow U_o = 864.5 \text{ W/m}^2.K \quad (\text{Ans.})$$



# Lesson 24 Expansion Devices

## The specific objectives of this lecture are to:

1. Discuss the basic functions of expansion devices used in refrigeration systems and their classification (*Section 24.1*)
2. Discuss the operating principle, concept of balance point, the effect of load variation, selection of capillary tubes using analytical and graphical methods and the advantages and disadvantages of capillary tubes (*Section 24.2*)
3. Explain the working principle of an automatic expansion valve, its performance under varying loads and its applications (*Section 24.3*)
4. Present a simple analysis for fluid through orifices (*Section 24.4*)
5. Explain the working principle of a thermostatic expansion valve, its performance under varying loads, variations available such as cross-charging, external equalizer and limit charging, advantages and disadvantages of TEVs (*Section 24.5*)
6. Explain the working principle of low-side and high-side float valves (*Section 24.6*)
7. Explain the working principle of an electronic expansion valve (*Section 24.7*)
8. Discuss briefly some of the practical problems with expansion devices (*Section 24.8*)

At the end of the lecture, the student should be able to:

1. Explain the basic functions of expansion devices in refrigeration systems
2. Explain the working principle and salient features of capillary tube, automatic expansion valve, thermostatic expansion valve, float type expansion valve and electronic expansion valve
3. Estimate the required length of capillary tubes using analytical and graphical methods
4. Describe advantages, disadvantages and applications of different types of expansion valves, and
5. Discuss some of the practical problems encountered in the operation of various types of expansion devices in refrigeration systems

### 24.1. Introduction

An expansion device is another basic component of a refrigeration system. The basic functions of an expansion device used in refrigeration systems are to:

1. Reduce pressure from condenser pressure to evaporator pressure, and
2. Regulate the refrigerant flow from the high-pressure liquid line into the evaporator at a rate equal to the evaporation rate in the evaporator

Under ideal conditions, the mass flow rate of refrigerant in the system should be proportional to the cooling load. Sometimes, the product to be cooled is such

that a constant evaporator temperature has to be maintained. In other cases, it is desirable that liquid refrigerant should not enter the compressor. In such a case, the mass flow rate has to be controlled in such a manner that only superheated vapour leaves the evaporator. Again, an ideal refrigeration system should have the facility to control it in such a way that the energy requirement is minimum and the required criterion of temperature and cooling load are satisfied. Some additional controls to control the capacity of compressor and the space temperature may be required in addition, so as to minimize the energy consumption.

The expansion devices used in refrigeration systems can be divided into *fixed opening type* or *variable opening type*. As the name implies, in fixed opening type the flow area remains fixed, while in variable opening type the flow area changes with changing mass flow rates. There are basically seven types of refrigerant expansion devices. These are:

1. Hand (manual) expansion valves
2. Capillary Tubes
3. Orifice
4. Constant pressure or Automatic Expansion Valve (AEV)
5. Thermostatic Expansion Valve (TEV)
6. Float type Expansion Valve
  - a) High Side Float Valve
  - b) Low Side Float Valve
7. Electronic Expansion Valve

Of the above seven types, Capillary tube and orifice belong to the fixed opening type, while the rest belong to the variable opening type. Of the above seven types, the hand operated expansion valve is not used when an automatic control is required. The orifice type expansion is used only in some special applications. Hence these two are not discussed here.

## 24.2 Capillary Tube

A capillary tube is a long, narrow tube of constant diameter. The word “capillary” is a misnomer since surface tension is not important in refrigeration application of capillary tubes. Typical tube diameters of refrigerant capillary tubes range from 0.5 mm to 3 mm and the length ranges from 1.0 m to 6 m.

The pressure reduction in a capillary tube occurs due to the following two factors:

1. The refrigerant has to overcome the frictional resistance offered by tube walls. This leads to some pressure drop, and

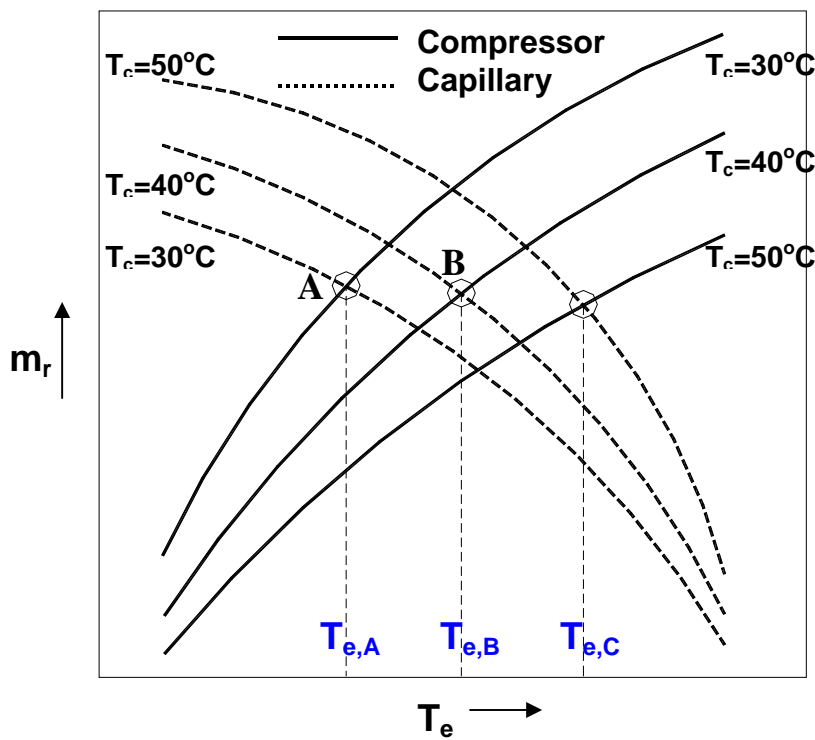
2. The liquid refrigerant flashes (evaporates) into mixture of liquid and vapour as its pressure reduces. The density of vapour is less than that of the liquid. Hence, the average density of refrigerant decreases as it flows in the tube. The mass flow rate and tube diameter (hence area) being constant, the velocity of refrigerant increases since  $\dot{m} = \rho VA$ . The increase in velocity or acceleration of the refrigerant also requires pressure drop.

Several combinations of length and bore are available for the same mass flow rate and pressure drop. However, once a capillary tube of some diameter and length has been installed in a refrigeration system, the mass flow rate through it will vary in such a manner that the total pressure drop through it matches with the pressure difference between condenser and the evaporator. Its mass flow rate is totally dependent upon the pressure difference across it; it cannot adjust itself to variation of load effectively.

#### **24.2.1. Balance Point of Compressor and Capillary Tube**

The compressor and the capillary tube, under steady state must arrive at some suction and discharge pressures, which allows the same mass flow rate through the compressor and the capillary tube. This state is called the balance point. Condenser and evaporator pressures are saturation pressures at corresponding condenser and evaporator temperatures. Figure 24.1 shows the variation of mass flow rate with evaporator pressure through the compressor and the capillary tube for three values of condenser temperatures namely, 30, 40 and 50°C.

The mass flow rate through the compressor decreases if the pressure ratio increases since the volumetric efficiency of the compressor decreases with the increase of pressure ratio. The pressure ratio increases when either the evaporator pressure decreases or the condenser pressure increases. Hence, the mass flow rate through the compressor decreases with increase in condenser pressure and/or with decrease in evaporator pressure.



**Fig.24.1:** Variation of refrigerant mass flow rate through compressor and capillary tube with evaporator and condenser temperatures (A,B & C are the balance points)

The pressure difference across the capillary tube is the driving force for the refrigerant to flow through it, hence mass flow rate through the capillary tube increases with increase in pressure difference across it. Thus the mass flow rate through the capillary tube increases as the condenser pressure increases and/or the evaporator pressure decreases. The variation of mass flow rate through capillary tube is shown for three condenser temperatures, namely, 30, 40 and  $50^\circ\text{C}$  in Figure 24.1. This is the opposite of the effect of pressures on the compressor mass flow rate. Hence, for a given value of condenser pressure, there is a definite value of evaporator pressure at which the mass flow rates through the compressor and the evaporator are the same. This pressure is the balance point that the system will acquire in steady state. Hence, for a given condenser temperature, there is a definite value of evaporator temperature at which the balance point will occur. Figure 28.1 shows a set of three balance points A, B and C for the three condenser temperatures. These balance points occur at evaporator temperatures of  $T_{e,A}$ ,  $T_{e,B}$  and  $T_{e,C}$ . It is observed that the evaporator temperature at balance point increases with increase of condenser temperature.

### 24.2.2. Effect Of load variation

The situation described above is in steady state. However, in practice the refrigeration load may vary due to several reasons, such as the variation of ambient temperatures etc. It is possible for the load to increase or decrease. This variation of load affects the operation of compressor and capillary tube and affects the balance point between them.

### Increase in refrigeration Load:

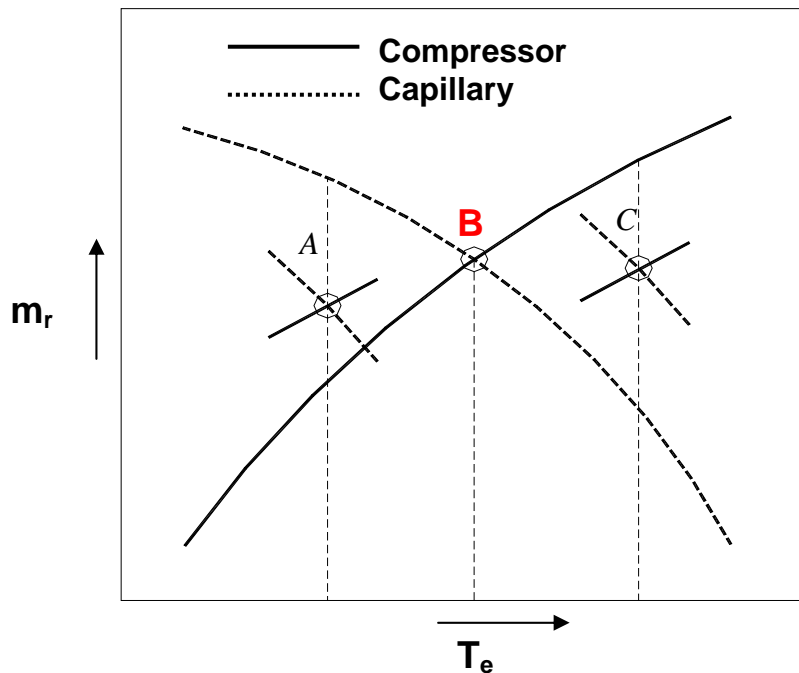
If the refrigeration load increases, there is a tendency for the evaporator temperature to increase due to higher rate of evaporation. This situation is shown in Figure 24.2 for a condenser temperature of 40°C. The balance point for design load is shown by point B. As the load increases, the evaporator temperature rises to C. At point C the mass flow rate through compressor is more than the mass flow rate through the capillary tube. In such a situation, the compressor will draw more refrigerant through the evaporator than the capillary tube can supply to it. This will lead to *starving* of the evaporator. However, emptying of evaporator cannot continue indefinitely. The system will take some corrective action since changes are occurring in the condenser also. Since the capillary tube feeds less refrigerant to the evaporator, the refrigerant accumulates in the condenser. The accumulation of refrigerant in the condenser reduces the effective area of the condenser that is available for heat transfer. The condenser heat transfer rate is given by,  $Q_c = U_c A_c (T_c - T_\infty)$ . If heat transfer coefficient  $U_c$  and  $T_\infty$  are constant, then for same heat transfer rate a decrease in area  $A_c$  will lead to a higher condenser temperature  $T_c$ . It is observed from Figure 24.1 that an increase in condenser temperature leads to a decrease in compressor mass flow rate and an increase in capillary mass flow rate. Hence, the system will find a new balance point at higher condenser temperature.

The second possibility is that at lower evaporator mass flow rate, the Reynolds number decreases and as a result, the heat transfer coefficient of evaporator decreases. Or in a flooded evaporator, the reduction in mass flow rate reduces the wetted surface area and the heat transfer coefficient. Therefore, larger temperature difference is required in the evaporator for the same amount of heat transfer. This decreases the evaporator temperature and corresponding pressure to the previous values.

### Decrease In refrigeration Load

If the refrigeration load decreases, there is a tendency for the evaporator temperature to decrease, say to state A as shown in Figure 28.2. In this condition the capillary tube feeds more refrigerant to the evaporator than the compressor can remove. This leads to accumulation of liquid refrigerant in the evaporator causing *flooding* of the evaporator. This may lead to dangerous consequences if the liquid refrigerant overflows to the compressor causing *slugging* of the compressor. This has to be avoided at all costs; hence the capillary tube based refrigeration systems use *critical charge* as a safety measure. Critical charge is a definite amount of refrigerant that is put into the refrigeration system so that in the eventuality of all of it accumulating in the evaporator, it will just fill the evaporator up to its brim and never overflow from the evaporator to compressor. The flooding of the evaporator is also a transient phenomenon, it cannot continue indefinitely. The system has to take some corrective action. Since the capillary tube feeds more refrigerant from the condenser, the liquid seal at the condenser-

exit breaks and some vapour enters the capillary tube. The vapour has a very small density compared to the liquid; as a result the mass flow rate through the capillary tube decreases drastically. This situation is shown in Figure 28.2. This is not desirable since the refrigeration effect decreases and the COP also decreases. Hence, attempts are made in all the refrigeration plants to subcool the refrigerant before entry to the expansion device. A vapour to liquid subcooling heat exchanger is usually employed, wherein the low temperature refrigerant vapour leaving the evaporator subcools the liquid leaving the condenser.



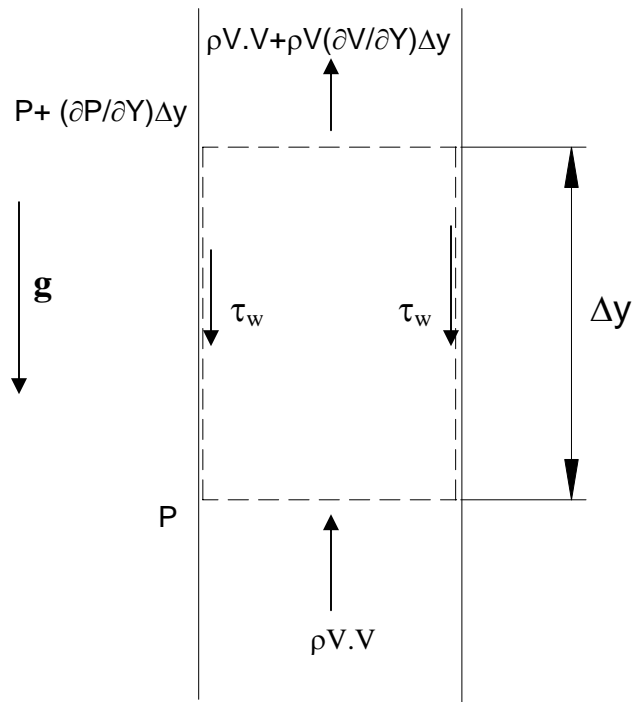
**Fig.24.2:** Effect of load variation on capillary tube based refrigeration systems. B: Design point; A: At low load; C: At high load

### 24.2.3. Selection of Capillary Tube

For any new system, the diameter and the length of capillary tube have to be selected by the designer such that the compressor and the capillary tube achieve the balanced point at the desired evaporator temperature. There are analytical and graphical methods to select the capillary tube. The fine-tuning of the length is finally done by *cut-and-try* method. A tube longer than the design (calculated) value is installed with the expected result that evaporating temperature will be lower than expected. The tube is shortened until the desired balance point is achieved. This is done for mass production. If a single system is to be designed then tube of slightly shorter length than the design length is chosen. The tube will usually result in higher temperature than the design value. The tube is pinched at a few spots to obtain the required pressure and temperature.

## Analytical Method

The analysis of flow through a capillary tube is one of the interesting problems that illustrate how a simple one-dimensional analysis yields good results. In a capillary tube the flow is actually compressible, three-dimensional and two-phase flow with heat transfer and thermodynamic meta-stable state at the inlet of the tube. However, in the simplified analysis, the flow is assumed to be steady, one-dimensional and in single phase or a homogenous mixture. One-dimensional flow means that the velocity does not change in the radial direction of the tube. Homogeneous means annular flow or plug flow model etc. or not considered for the two-phase flow. Figure 28.3 shows a small section of a vertical capillary tube with momentum and pressure at two ends of an elemental control volume.



**Fig.24.3:** A small section of a capillary tube considered for analysis

Applying mass and momentum conservation for a control volume shown in Fig. 24.3, we get:

Mass Conservation:

$$\rho VA + \frac{\partial(\rho V)}{\partial y} \Delta y A - \rho VA = 0 \quad (24.1)$$



$$\frac{\partial(\rho V)}{\partial y} = 0.0 \therefore \rho V = \text{constant}$$

Momentum Conservation:

The momentum theorem is applied to the control volume. According to this, [Momentum]<sub>out</sub> – [Momentum]<sub>in</sub> = Total forces on control volume

$$\pi R^2 [\rho V V + \rho V \frac{\partial V}{\partial y} \Delta y] - \pi R^2 [\rho V V] = - \pi R^2 \frac{\partial p}{\partial y} \Delta y - \rho_{avg} g \pi R^2 \Delta y - 2 \pi R \Delta y \tau_w \quad (24.2)$$

At the face  $y + \Delta y$ , Taylor series expansion has been used for pressure and momentum and only the first order terms have been retained. The second order terms with second derivatives and higher order terms have been neglected. If the above equation is divided by  $\pi R^2 \Delta y$  and limit  $\Delta y \rightarrow 0$  is taken; then all the higher order terms will tend to zero if these were included since these will have  $\Delta y$  or its higher power of  $\Delta y$  multiplying them. Also,  $\rho_{avg}$  will tend to  $\rho$  since the control volume will shrink to the bottom face of the control volume where  $\rho$  is defined. Further, neglecting the effect of gravity, which is very small, we obtain:

$$\rho V \frac{\partial V}{\partial y} = - \frac{\partial p}{\partial y} - 2 \frac{\tau_w}{R} \quad (24.3)$$

The wall shear stress may be written in terms of friction factor. In fluid flow through pipes the pressure decreases due to shear stress. This will be referred to as frictional pressure drop and a subscript 'f' will be used with it and it will be written in terms of friction factor. The Darcy's friction factor is for fully developed flow in a pipe. In fully developed flow the velocity does not change in the flow direction. In case of a capillary tube it increases along the length. Still it is good approximation to approximate the shear stress term by friction factor. For fully developed flow the left hand side of Equation (28.3) is zero, hence the frictional pressure drop  $\Delta p_f$  may be obtained from the following equation:

$$\tau_w = R \Delta p_f / (2 \Delta y) \quad (24.4)$$

The friction factor is defined as

$$\Delta p_f = \rho f \frac{\Delta y}{D} \frac{V^2}{2} \quad (24.5)$$

Substituting Eqn.(28.5) in Eqn.(28.4) we get

$$\tau_w = \rho f V^2 / 8 \quad (24.6)$$

Substituting for  $\tau_w$  in Eqn.(28.3) we have:

$$\rho V \frac{\partial V}{\partial y} = - \frac{\partial p}{\partial y} - \frac{\rho f V^2}{2D} \quad (24.7)$$

Mass conservation Eqn.(28.1) indicates that the product  $\rho V$  is constant in the tube. In fact it is called mass velocity and is denoted by  $G$ ,

$$\mathbf{G} = \rho V$$

We have mass flow rate  $\dot{m} = [\pi D^2/4] \rho V$

$$\therefore \rho V = \dot{m} / A = \mathbf{G} = \text{constant} \quad (24.8)$$

Hence Eqn.(28.7) is rewritten as follows

$$\mathbf{G} \frac{\partial V}{\partial y} = - \frac{\partial p}{\partial y} - \frac{f V \mathbf{G}}{2D} \quad (24.9)$$

In this equation the term on the left hand side is the acceleration of fluid. The first term on the right hand side is the pressure drop required to accelerate the fluid and to overcome the frictional resistance. The second term on the right hand side is the frictional force acting on the tube wall. The friction factor depends upon the flow Reynolds number and the wall roughness for the fully developed flow. For the developing flow it is function of distance along the tube also in addition to Reynolds number. The flow accelerates along the tube due to vapour formation, as a result, the Reynolds number increases along the tube. The velocity and Reynolds number vary in a complex manner along the tube and these are coupled together. Hence, an exact solution of Eqn.(24.9) is not possible. To a good approximation the integral of product  $f V$ , that is,  $\int f V dy$  can be calculated by assuming average value of the product  $f V$  over a small length  $\Delta L$  of the capillary tube.

Accordingly, integrating Equation (24.9) over a small length  $\Delta L$  of the capillary tube we obtain

$$\mathbf{G} \Delta V = -\Delta p - [fV]_{\text{mean}} \mathbf{G} \Delta L / 2D \quad (24.10)$$

$$\Delta p = \mathbf{G} \Delta V + [\mathbf{G} / 2D] [f V]_{\text{mean}} \Delta L \quad (24.11)$$

Where,  $\Delta V = V_{i+1} - V_i$  and  $\Delta p = p_{i+1} - p_i$

$\Delta p$  is negative since  $p_i > p_{i+1}$ .

Equation (24.11) may be expressed as follows

$$\Delta p = \Delta p_{\text{accln}} + \Delta p_f$$

This means that total pressure drop over a length  $\Delta L$  is the sum of that required for acceleration and that required to overcome frictional resistance.

For laminar flow the effect of wall roughness is negligible and friction factor is given by

$$f = 64/Re \quad (24.12)$$

For turbulent flow the friction factor increases with increase in roughness ratio. Moody's chart gives the variation of friction factor with Reynolds numbers for various roughness ratios. A number of empirical expressions are also available for friction factor in standard books on Fluid Mechanics. One such expression for the smooth pipe, known as Blasius Correlation is as follows:

$$f = 0.3164 Re^{-0.25} \approx 0.32 Re^{-0.25} : \text{for } Re < 10^5 \quad (24.13)$$

The solution procedure for Eqn.(24.11) as suggested by Hopkins and Copper and Brisken is as follows:

The condenser and evaporator temperatures  $T_c$  and  $T_e$ , the refrigerant and its mass flow rate are usually specified and the length and bore of capillary tube are required. Eqn.(24.11) is valid for a small length of the tube. Hence, the tube is divided into small lengths  $\Delta L_i$  such that across each incremental length a temperature drop  $\Delta t_i$  of say 1 or 2 degrees takes place depending upon the accuracy of calculation required. The length of the tube  $\Delta L_i$  for temperature to drop by say, 1°C is found from Eqn.(24.11). The temperature base is taken for calculations instead of pressure base since the refrigerant properties are available on basis of temperature.

1. Assume an appropriate diameter  $D$  for the tube. At condenser exit and inlet to capillary tube point "0" shown in Figure 24.4, say the state is saturated liquid state hence,

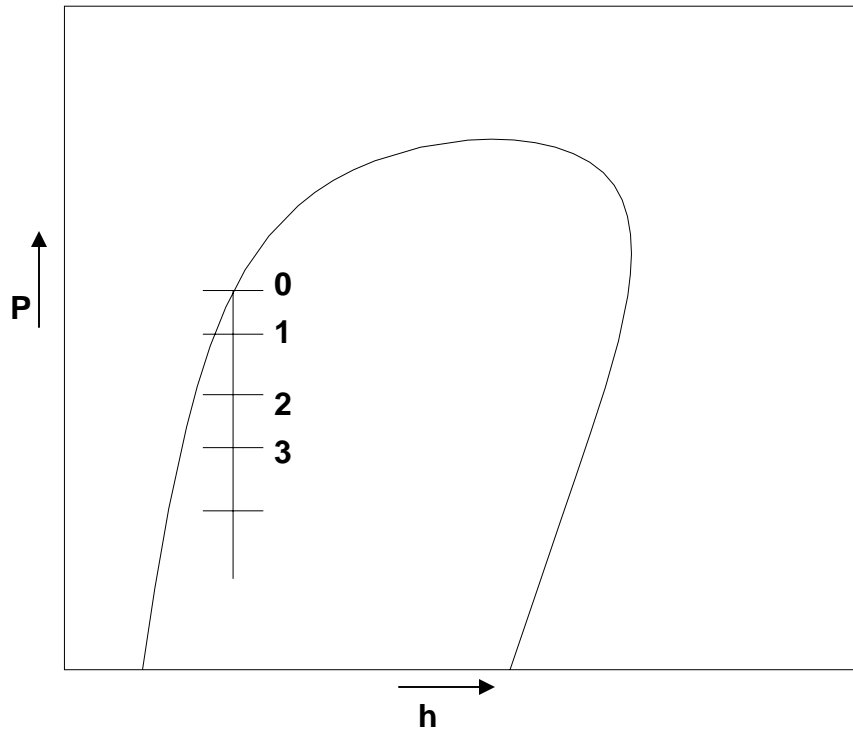
$$v_0 = v_f, h_0 = h_f, \mu_0 = \mu_f \text{ and}$$

$\dot{m}$  is known from thermodynamic cycle calculation for the given cooling capacity.

$$\therefore Re = 4 \dot{m} / (\pi D \mu),$$

$$G = \dot{m} / A = \rho V = V/v$$

The constants in Eqn.(24.11)  $G$ ,  $G/(2D)$  and  $4 \dot{m} / \pi D$  required for solution are then calculated.



**Fig.24.4:** Step-wise calculation procedure for capillary tube length on p-h diagram

2. At inlet  $i = 0$  :  $Re_0 = 4 \dot{m} / (\pi D \mu_0)$ ,  $f_0 = 0.32 Re^{-0.25}$  and  $V_0 = v_0 G$

3. At  $i = 1$  in Figure 10.6:  $t_1 = t_c - \Delta t_1$ , find the saturation pressure  $p_1$  at  $t_1$ . The saturation properties  $v_{1f}$ ,  $v_{1g}$ ,  $h_{1f}$ ,  $h_{1g}$  and  $\mu_{1f}$  and  $\mu_{1g}$  are obtained at  $t_1$ . It is assumed that the enthalpy remains constant during expansion as shown in Figure 28.5.

4. If  $x_1$  is the dryness fraction at  $i = 1$ , then

$$h_0 = h_1 = x_1 h_{1g} + (1 - x_1) h_{1f} \quad (24.14)$$

$$\therefore x_1 = [h_0 - h_{1f}] / [h_{1g} - h_{1f}]$$

5. Find  $v_1 = x_1 v_{1g} + (1 - x_1) v_{1f}$

Assuming that viscosity of mixture can be taken as weighted sum of viscosity of saturated liquid and vapour we get,

$$\mu_1 = x_1 \mu_{1g} + (1 - x_1) \mu_{1f}$$

$$Re_1 = 4 \dot{m} / (\pi D \mu_1), \quad f_1 = 0.32 Re^{-0.25} \text{ and } V_1 = v_1 G$$

$$\Delta V = V_1 - V_0$$

$$\Delta p = p_0 - p_1$$

$$[fV]_{\text{mean}} = [f_0 V_0 + f_1 V_1] / 2$$

Hence, from Eqn.(24.11) the incremental length of capillary tube for the first step,  $\Delta L_1$  is,

$$\Delta L_1 = \frac{-\Delta p - G \Delta V}{(G/2D) (fV)_{\text{mean}}}$$

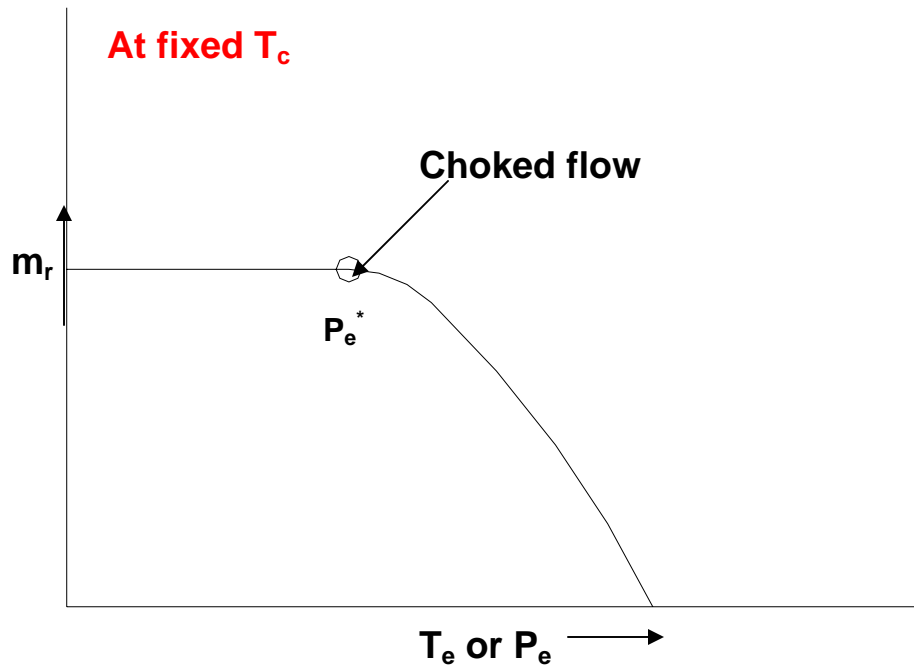
6. For the next section  $i = 2$  :  $t_2 = t_1 - \Delta t_2$ , find the saturation pressure  $p_2$  at  $t_2$ . The saturation properties  $v_{2f}$ ,  $v_{2g}$ ,  $h_{2f}$ ,  $h_{2g}$  and  $\mu_{2f}$  and  $\mu_{2g}$  are obtained at temperature  $t_2$ .

7. Assuming the enthalpy to remain constant, that is  $h_2 = h_1 = h_0$ , the quality  $x_2$  is found and steps 4 and 5 are repeated to find the incremental length  $\Delta L_2$ .

Steps 4 and 5 are repeated for all the intervals up to evaporator temperature and all the incremental lengths are summed up to find the total length of the capillary tube.

It is observed from Eqn.(24.11) that the total pressure drop is the sum of pressure drops due to acceleration that is,  $\Delta p_{\text{accln}} = G \Delta V$  and the pressure drop due to friction, that is,  $\Delta p_f = [G/2D] [fV]_{\text{mean}} \Delta L$ . It may so happen under some conditions that after a few steps of calculation, the total pressure drop required for a segment may become less than the pressure drop required for acceleration alone,  $\Delta p < \Delta p_{\text{accln}}$ . The increment length  $\Delta L$  for this segment will turn out to be negative which has no meaning. This condition occurs when the velocity of refrigerant has reached the velocity of sound (sonic velocity). This condition is called *choked flow condition*. The velocity of fluid cannot exceed the velocity of sound in a tube of constant diameter, hence the calculation cannot proceed any further. The flow is said to be choked-flow and the mass flow rate through the tube has reached its maximum value for the selected tube diameter. For a capillary tube of constant diameter, choked flow condition represents the minimum suction pressure that can be achieved. If further pressure drop is required a tube of larger diameter should be chosen in which the velocity of sound occurs at larger length.

Figure 24.5 shows the variation mass flow rate with suction pressure for fixed condenser pressure. The mass flow rate through the capillary tube increases as the evaporator pressure decreases. However at a pressure of  $p^*$  the flow is choked. If the choking occurs at some interior point of the tube, the length of the tube from this point to the exit will offer frictional resistance to the flow and the pressure must decrease to overcome this. The pressure however cannot decrease since the flow is choked. Hence, adjustment in the inlet conditions occurs and the mass flow rate is reduced so that the flow will (always) be choked at the exit of the tube with reduced mass flow rate. This is typical of compressible sonic flow where upstream influence occurs; otherwise the downstream pressure decides the mass flow rate.

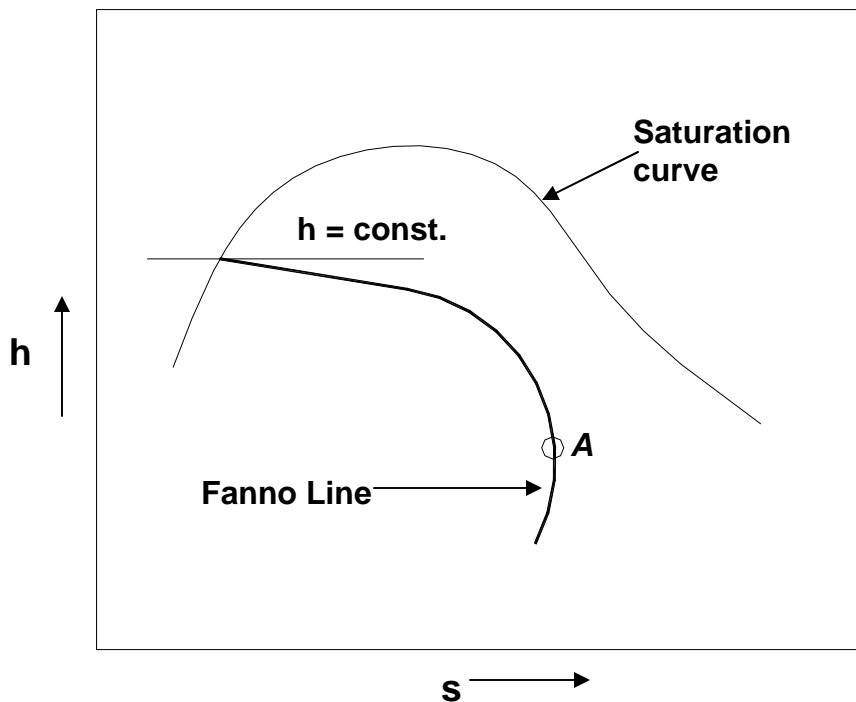


**Fig.24.5:** Variation mass flow rate with suction pressure for fixed condenser pressure

### Shortcomings of the above analysis

It is assumed in the above analysis that the expansion is a constant enthalpy process. This is strictly not true inside a capillary tube since there is a large change in kinetic energy due to change in velocity along the length due to flashing of refrigerant liquid. In fact kinetic energy increases at a very fast rate as the velocity becomes sonic and the flow becomes choked. First law of thermodynamics indicates that in absence of heat transfer, work done and change in potential energy for a system in steady state, the sum of enthalpy and the kinetic energy must remain constant. Hence, if the kinetic energy increases the enthalpy must decrease, as a result the quality of the refrigerant will be lower than calculated by assuming constant enthalpy. The actual state of refrigerant in a constant diameter adiabatic tube is represented by *Fanno line*, which is shown in Fig.24.6 on  $h-s$  diagram along with the saturation curve. Fanno line is the solution of steady, compressible adiabatic flow with friction through a tube of constant diameter.

It is observed that in the early part of the capillary tube, the constant enthalpy line does not deviate very much from the Fanno line. In the latter part, the deviation from the Fanno line increases. Most of the length of the capillary tube happens to be in the latter portion where quality and velocity changes are very significant; hence constant enthalpy approximation may introduce significant error.



**Fig.24.6:** Fanno line for capillary tube on h-s diagram

Point A on the Fanno line is the point where the entropy is maximum. This point corresponds to choked flow condition. Pressure cannot drop below this value since it will require a decrease in entropy under adiabatic condition, which is not possible in a real system. This would mean violation of second law of thermodynamics.

### Modified Procedure

It is observed that the Kinetic energy changes significantly in the latter part of the capillary tube. In step 4 of the calculation procedure enthalpy was assumed to be constant. To improve upon it, the quality is calculated by considering energy balance, that is, the sum of enthalpy and kinetic energy is assumed to remain constant. The quality of the mixture is not found from Eqn.(24.14). Instead, sum of enthalpy and kinetic energy is taken as constant. For the first segment we get

$$h_0 + V_0^2/2 = h_1 + V_1^2/2 = h_1 + G^2 v_1^2/2 \quad (24.15)$$

Substituting for  $h_1$  and  $v_1$  in terms of quality  $x_1$  and properties at saturation, we get

$$\begin{aligned} x_1 h_{1g} + (1 - x_1) h_{1f} + G^2 [x_1 v_{1g} + (1 - x_1) v_{1f}]^2 / 2 &= h_0 + V_0^2/2, \text{ or} \\ h_{1f} + x_1 h_{1fg} + G^2 [v_{1f} + x_1 v_{1fg}]^2 / 2 &= h_0 + V_0^2/2, \text{ or} \\ x_1^2 [v_{1fg}^2 G^2/2] + x_1 [G^2 v_{1f} v_{1fg} + h_{1fg}] + (h_{1f} - h_0) + (G^2/2) v_{1f}^2 - V_0^2/2 &= 0 \end{aligned}$$

This is a quadratic equation for  $x_1$  that can be solved to find  $x_1$ . The positive root of this equation is taken as the value of  $x_1$ . The enthalpy is usually given in kJ/kg and velocity in m/s, hence to make the equation dimensionally consistent, the enthalpy is multiplied by 1000, that is,

$$x_1^2[v_{1fg}^2 G^2/2]+x_1[G^2 v_{1f} v_{1fg}+1000h_{1fg}]+1000(h_{1f}-h_0)+(G^2/2)v_{1f}^2-V_o^2/2=0 \quad (24.16)$$

The remaining part of the procedure from step 5 to 6 remains the same. For all subsequent steps, the quality is calculated from Eqn.(24.1).

If the entry state of refrigerant to the capillary tube is subcooled, then length required for the pressure to drop from the condenser pressure to the saturated state (which occurs at an intermediate pressure) is calculated and is added to the length required to reduce the pressure from the intermediate saturated pressure to the final evaporator pressure. Calculation of the length for the first part (i.e., in the subcooled liquid region) can be done in a single step as there is no change of phase. For this single phase region, the enthalpy can be assumed to be constant as the change in kinetic energy is negligible. Thus from the known inlet enthalpy corresponding to the subcooled state at condenser pressure, drawing an isenthalpic line, gives the intermediate saturation pressure. For the two-phase region, the above procedure has to be used with the inlet conditions corresponding to the saturated intermediate pressure.

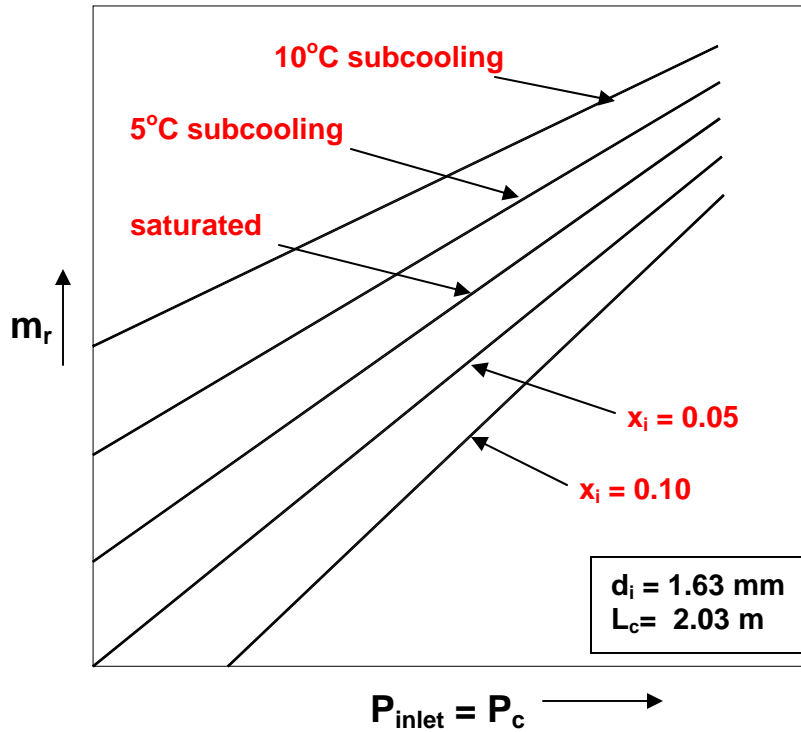
### Graphical Procedure

A graphical procedure for capillary tube selection has been presented in ASHRAE Handbook. A representative Figure 24.7 gives the mass flow rate of refrigerant through capillary tube at various inlet pressures, sub-cooling and dryness fraction through a capillary tube of 1.63 mm diameter and 2.03 m length. The companion Figure 24.8 gives the flow correction factor  $\phi$  for diameters and lengths different from that used in Fig.24.8. The mass flow rate for any diameter  $d_i$  and length  $L_c$  is given by:

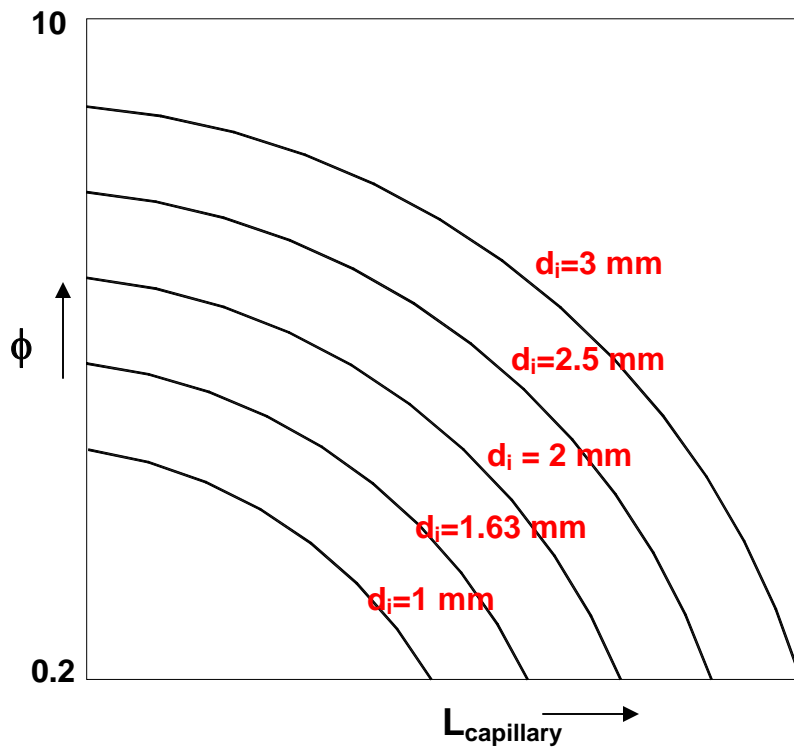
$$m_{di,Lc} = m_{1.63 \text{ mm}, 2.03 \text{ m}} \cdot \phi \quad (24.17)$$

These plots are for choked flow conditions. Corrections for non-choked flow conditions are given in ASHRAE Handbook.





**Fig.24.7:** Variation of refrigerant mass flow rate with inlet state for the standard capillary tube (Choked flow condition)



**Fig.24.8:** Variation of flow correction factor  $\phi$  with capillary tube length and diameter (Choked flow condition)

#### 24.2.4. Advantages and disadvantages of capillary tubes

Some of the advantages of a capillary tube are:

1. It is inexpensive.
2. It does not have any moving parts hence it does not require maintenance
3. Capillary tube provides an open connection between condenser and the evaporator hence during off-cycle, pressure equalization occurs between condenser and evaporator. This reduces the starting torque requirement of the motor since the motor starts with same pressure on the two sides of the compressor. Hence, a motor with low starting torque (squirrel cage Induction motor) can be used.
4. Ideal for hermetic compressor based systems, which are critically charged and factory assembled.

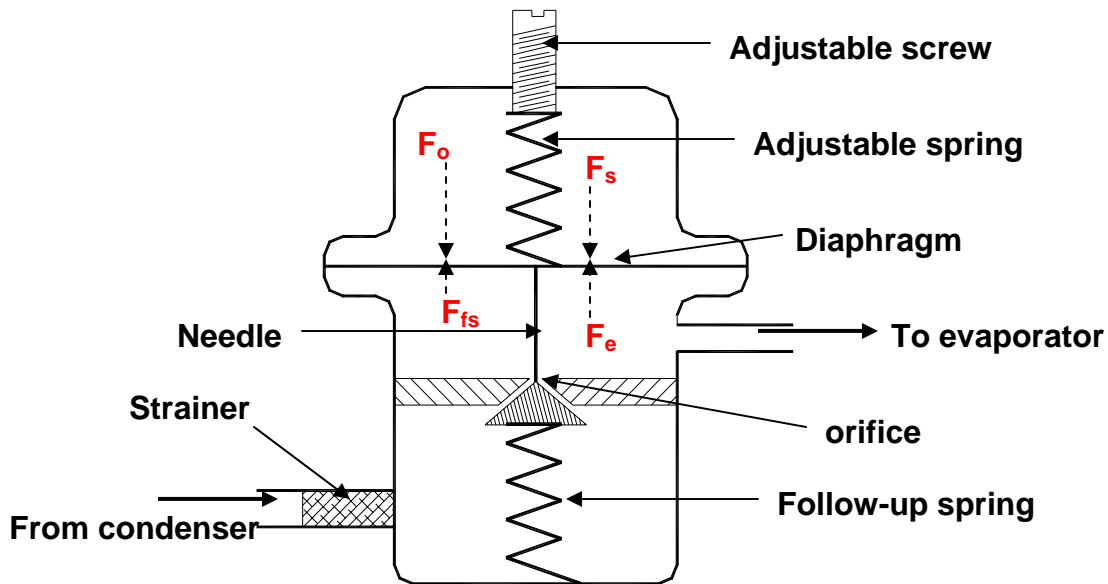
Some of the disadvantages of the capillary tube are:

1. It cannot adjust itself to changing flow conditions in response to daily and seasonal variation in ambient temperature and load. Hence, COP is usually low under off design conditions.
2. It is susceptible to clogging because of narrow bore of the tube, hence, utmost care is required at the time of assembly. A filter-drier should be used ahead of the capillary to prevent entry of moisture or any solid particles
3. During off-cycle liquid refrigerant flows to evaporator because of pressure difference between condenser and evaporator. The evaporator may get flooded and the liquid refrigerant may flow to compressor and damage it when it starts. Therefore critical charge is used in capillary tube based systems. Further, it is used only with hermetically sealed compressors where refrigerant does not leak so that critical charge can be used. Normally an accumulator is provided after the evaporator to prevent slugging of compressor

#### 24.3. Automatic Expansion Valve (AEV)

An Automatic Expansion Valve (AEV) also known as a constant pressure expansion valve acts in such a manner so as to maintain a constant pressure and thereby a constant temperature in the evaporator. The schematic diagram of the valve is shown in Fig. 24.9. As shown in the figure, the valve consists of an adjustment spring that can be adjusted to maintain the required temperature in the evaporator. This exerts force  $F_s$  on the top of the diaphragm. The atmospheric pressure,  $P_o$  also acts on top of the diaphragm and exerts a force of  $F_o = P_o A_d$ ,  $A_d$  being the area of the diaphragm. The evaporator pressure  $P_e$  acts below the diaphragm. The force due to evaporator pressure is  $F_e = P_e A_d$ . The net downward force  $F_s + F_o - F_e$  is fed to the needle by the diaphragm. This net

force along with the force due to follow-up spring  $F_{fs}$  controls the location of the needle with respect to the orifice and thereby controls the orifice opening.



**Fig.24.9:** Schematic of an Automatic Expansion Valve

If  $F_e + F_{fs} > F_s + F_o$  the needle will be pushed against the orifice and the valve will be fully closed.

On the other hand if  $F_e + F_{fs} < F_s + F_o$ , the needle will be away from the orifice and the valve will be open. Hence the relative magnitude of these forces controls the mass flow rate through the expansion valve.

The adjustment spring is usually set such that during off-cycle the valve is closed, that is, the needle is pushed against the orifice. Hence,

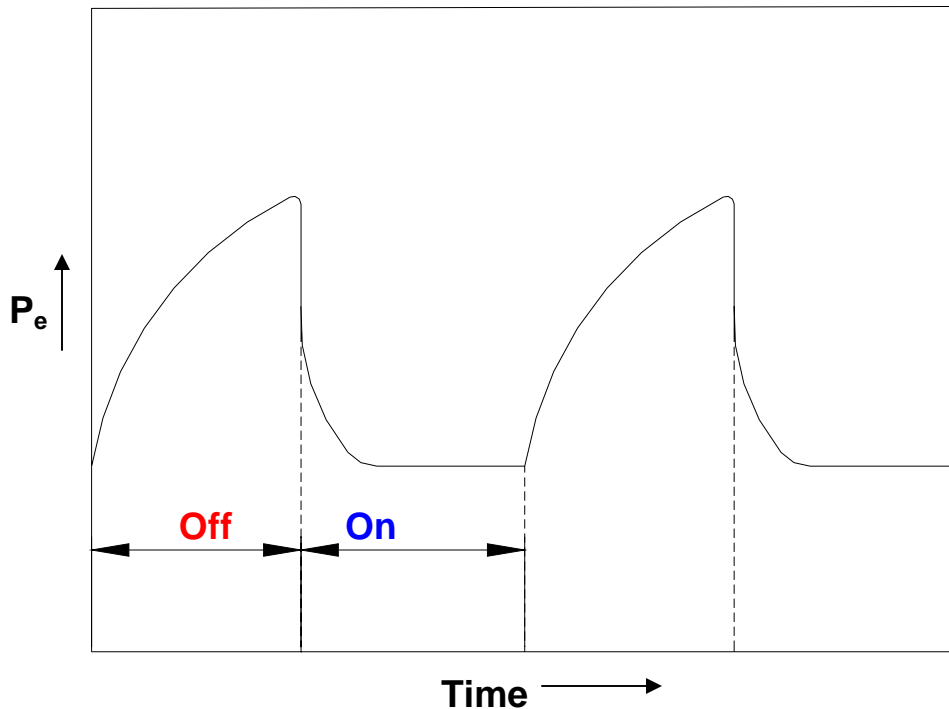
$$F_{e0} + F_{fs0} > F_{s0} + F_o$$

Where, subscript  $_o$  refers to forces during off cycle. During the off-cycle, the refrigerant remaining in the evaporator will vaporize but will not be taken out by the compressor, as a result the evaporator pressure rises during the off-cycle as shown in Fig.24.10.

When the compressor is started after the off-cycle period, the evaporator pressure  $P_e$  starts decreasing at a very fast rate since valve is closed; refrigerant is not fed to evaporator while the compressor removes the refrigerant from the evaporator. This is shown in Fig.24.10. As  $P_e$  decreases the force  $F_e$  decreases from  $F_{e0}$  to  $(F_{e0} - \Delta F_e)$ . At one stage, the sum  $F_e + F_{fs}$  becomes less than  $F_s + F_o$ ,

as a result the needle stand moves downwards (away from the needle stand) and the valve opens. Under this condition,

$$(F_{e0} - \Delta F_e) + F_{fs0} < F_{s0} + F_o$$



**Fig.24.10:** Variation of evaporator pressure during on- and off-cycles of an AEV based refrigeration system

When the refrigerant starts to enter the evaporator, the evaporator pressure does not decrease at the same fast rate as at starting time. Thus, the movement of the needle stand will slow down as the refrigerant starts entering. As the needle moves downwards, the adjustment spring elongates, therefore the force  $F_s$  decreases from its off-cycle value of  $F_{s0}$ , the decrease being proportional to the movement of the needle.

As the needle moves downwards, the follow-up spring is compressed; as a result,  $F_{fs}$  increases from its off-cycle value. Hence, the final equation may be written as,

$$(F_{e0} - \Delta F_e) + (F_{fs0} + \Delta F_{fs}) = (F_{s0} - \Delta F_s) + F_o \quad \text{or}$$

$$F_e + F_{fs} = F_s + F_o = \text{constant} \quad (24.18)$$

The constant is sum of force due to spring force and the atmospheric pressure, hence it depends upon position of adjustment spring. This will be the equilibrium position. Then onwards, the valve acts in such a manner that the

evaporator pressure remains constant as long as the refrigeration load is constant. At this point, the mass flow rate through the valve is the same as that through the compressor.

### 24.3.1. Effect of Load Variation

The mass flow rate through the valve is directly proportional to the pressure drop through the orifice ( $P_c - P_e$ ) and the area of the orifice opening (needle position). At constant condenser pressure the mass flow rate will decrease if the evaporator pressure  $p_e$  increases or as the orifice opening becomes narrower.

#### Decrease In Load

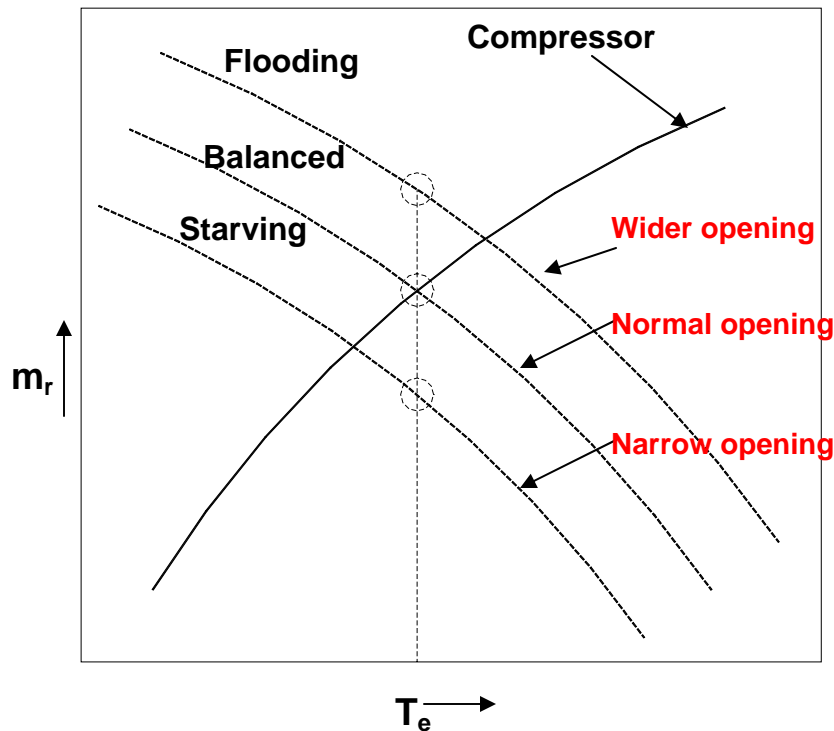
If the refrigeration load decreases, there is a tendency in the evaporator for the evaporator temperature to decrease and thereby the evaporator pressure (saturation pressure) also decreases. This decreases the force  $F_e$ . The sum  $F_e + F_{fs}$  will become less than the sum on right hand side of Equation (28.18) and the needle stand will be pushed downwards opening the orifice wider. This will increase the mass flow rate through the valve. This is opposite of the requirement since at lower load, a lower mass flow rate of the refrigerant is required. This is the drawback of this valve that it counteracts in an opposite manner since it tries to keep the evaporator pressure at a constant value. In Figure 24.11, point *A* is the normal position of the valve and *B* is the position at reduced load and wider opening. It is observed that both these are at same evaporator pressure. The compressor capacity remains the same as at *A*. The valve feeds more refrigerant to the evaporator than the compressor can remove from the evaporator. This causes accumulation of liquid refrigerant in the evaporator. This is called “flooding” of the evaporator. The liquid refrigerant may fill the evaporator and it may overflow to the compressor causing damage to it.

#### Increase In Load

On the other hand if the refrigeration load increases or the evaporator heat transfer rate increases, the evaporator temperature and pressure will increase for a flooded evaporator. This will increase  $F_e$ . A look at the schematic diagram reveals that this will tend to move the needle stand upwards, consequently making the orifice opening narrower and decreasing the mass flow rate. Again the valve counteracts in a manner opposite to what is required. This shifts the operating point from *A* to point *C* where the compressor draws out more refrigerant than that fed by the expansion valve leading to *starving* of the evaporator.

The adjustment of evaporator pressure and temperature is carried out by adjustment spring. An increase in the tension of adjustment spring increases  $F_s$

so that the evaporator pressure at which balance occurs, increases. That is, the regulated temperature increases.



**Fig.24.11:** Effect of load variation on balance point of the system using AEV

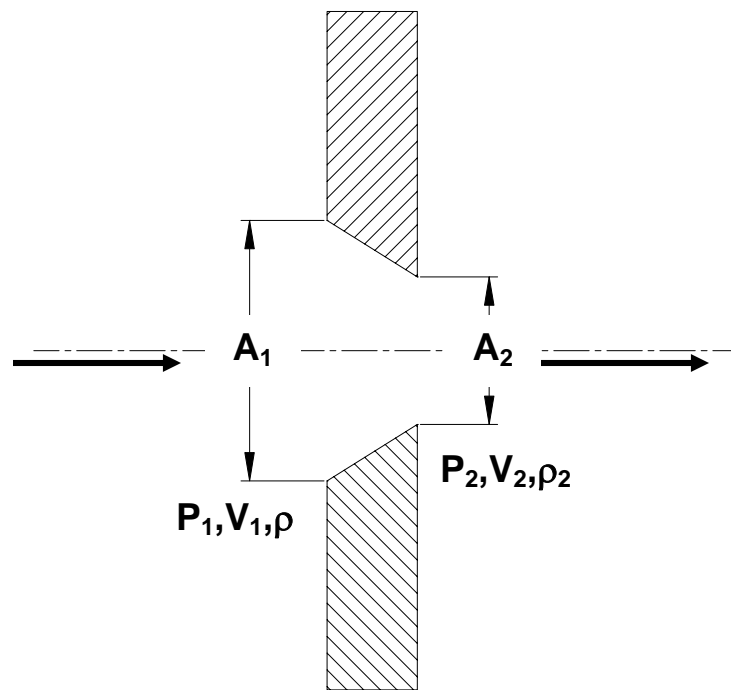
### 24.3.2. Applications of automatic expansion valve

The automatic expansion valves are used wherever constant temperature is required, for example, milk chilling units and water coolers where freezing is disastrous. In air-conditioning systems it is used when humidity control is by DX coil temperature. Automatic expansion valves are simple in design and are economical. These are also used in home freezers and small commercial refrigeration systems where hermetic compressors are used. Normally the usage is limited to systems of less than 10 TR capacities with critical charge. Critical charge has to be used since the system using AEV is prone to flooding. Hence, no receivers are used in these systems. In some valves a diaphragm is used in place of bellows.

## 24.4. Flow Rate through orifice

In variable area type expansion devices, such as automatic and thermostatic expansion valves, the pressure reduction takes place as the fluid flows through an orifice of varying area. Let  $A_1$  and  $A_2$  be the areas at the inlet and the outlet of the orifice where,  $A_1 > A_2$ . Let  $V_1$  and  $V_2$  be the velocities,  $P_1$  and

$P_2$  are the pressures and  $\rho_1$  and  $\rho_2$  be the densities at the inlet and outlet respectively of the orifice as shown in Figure 24.12.



**Fig.24.12:** Fluid flow through an orifice

Then assuming steady, incompressible, inviscid flow and neglecting gravity, Bernoulli's equation may be used to write the flow rate through the orifice as follows.

Mass Conservation:

$$\rho_1 V_1 A_1 = \rho_2 V_2 A_2 \quad (24.19)$$

Assuming  $\rho_1 = \rho_2$  we get

$$V_1 / V_2 = A_2 / A_1$$

Bernoulli's Equation:

$$\frac{P_1}{\rho_1} + \frac{V_1^2}{2} = \frac{P_2}{\rho_2} + \frac{V_2^2}{2} \quad (24.20)$$

Therefore,

$$\frac{P_1 - P_2}{\rho_1} = \frac{V_2^2}{2} \left( 1.0 - \frac{V_1^2}{V_2^2} \right) = \frac{V_2^2}{2} \left( 1.0 - \frac{A_2^2}{A_1^2} \right) \quad (24.21)$$

Ideal Flow Rate :

$$Q_{\text{ideal}} = A_2 V_2 = A_2 \sqrt{\frac{2(P_1 - P_2)}{\rho_1}} \frac{1.0}{\sqrt{1.0 - (A_2 / A_1)^2}} \quad (24.22)$$

Defining

$$M = \frac{1.0}{\sqrt{1.0 - (A_2 / A_1)^2}}, \text{ we get}$$

$$Q_{\text{ideal}} = M A_2 \sqrt{\frac{2(P_1 - P_2)}{\rho_1}} \quad (24.23)$$

The actual flow through the orifice is less than ideal flow because viscous effects are not included in the above treatment. An empirical coefficient  $C_D$ , called discharge coefficient is introduced to account for the viscous effects.

$$Q_{\text{actual}} = C_D Q_{\text{ideal}} = C_D M A_2 \sqrt{\frac{2(P_1 - P_2)}{\rho_1}} \quad (24.24)$$

Introducing flow coefficient  $K = C_D M$

$$Q_{\text{actual}} = K A_2 \sqrt{\frac{2(P_1 - P_2)}{\rho_1}}$$

To account for compressibility another empirical constant  $Y$  is introduced for actual mass flow rate. Hence, the mass flow rate is expressed as,

$$\dot{m} = K \rho_1 Y A_2 \sqrt{\frac{2(P_1 - P_2)}{\rho_1}} \quad (24.25)$$

The area of the orifice opening is usually controlled to control the mass flow rate through the expansion valve. It is observed that the mass flow rate depends upon the difference between the condenser and evaporator pressures also. It is curious that single phase relations have been given above while it was shown that during expansion of high pressure liquid, the refrigerant flashes into a low pressure mixture of liquid and vapour as it flows through the expansion valve. Actually, studies show that the refrigerant remains in a thermodynamic metastable liquid state as it flows through the orifice of the expansion valve. That is, it remains a liquid at a lower pressure and temperature during its passage through the orifice. It flashes into a mixture of liquid and vapour as soon as it emerges out of the orifice of the valve. This kind of phenomenon has been observed in the initial sections of transparent capillary tubes also.



## 24.5. Thermostatic Expansion Valve (TEV)

Thermostatic expansion valve is the most versatile expansion valve and is most commonly used in refrigeration systems. A thermostatic expansion valve maintains a constant degree of superheat at the exit of evaporator; hence it is most effective for dry evaporators in preventing the slugging of the compressors since it does not allow the liquid refrigerant to enter the compressor. The schematic diagram of the valve is given in Figure 24.13. This consists of a feeler bulb that is attached to the evaporator exit tube so that it senses the temperature at the exit of evaporator. The feeler bulb is connected to the top of the bellows by a capillary tube. The feeler bulb and the narrow tube contain some fluid that is called *power fluid*. The power fluid may be the same as the refrigerant in the refrigeration system, or it may be different. In case it is different from the refrigerant, then the TEV is called *TEV with cross charge*. The pressure of the power fluid  $P_p$  is the saturation pressure corresponding to the temperature at the evaporator exit. If the evaporator temperature is  $T_e$  and the corresponding saturation evaporator pressure is  $P_e$ , then the purpose of TEV is to maintain a temperature  $T_e + \Delta T_s$  at the evaporator exit, where  $\Delta T_s$  is the degree of superheat required from the TEV. The power fluid senses this temperature  $T_e + \Delta T_s$  by the feeler bulb and its pressure  $P_p$  is the saturation pressure at this temperature. The force  $F_p$  exerted on top of bellows of area  $A_b$  due to this pressure is given by:

$$F_p = A_b P_p \quad (24.26)$$

The evaporator pressure is exerted below the bellows. In case the evaporator is large and has a significant pressure drop, the pressure from evaporator exit is fed directly to the bottom of the bellows by a narrow tube. This is called pressure-equalizing connection. Such a TEV is called *TEV with external equalizer*, otherwise it is known as *TEV with internal equalizer*. The force  $F_e$  exerted due to this pressure  $P_e$  on the bottom of the bellows is given by

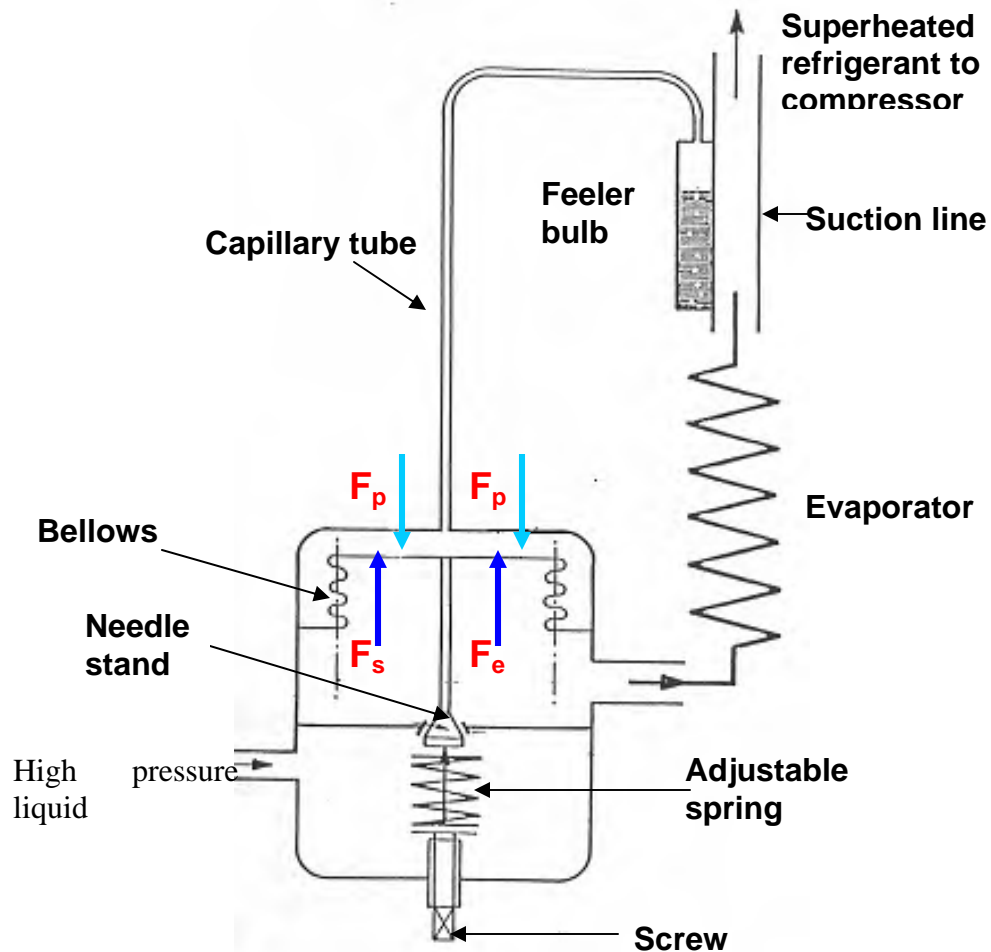
$$F_e = A_b P_e \quad (24.27)$$

The difference of the two forces  $F_p$  and  $F_e$  is exerted on top of the needle stand. There is an adjustment spring below the needle stand that exerts an upward spring force  $F_s$  on the needle stand. In steady state there will be a force balance on the needle stand, that is,

$$F_s = F_p - F_e \quad (24.28)$$

During off-cycle, the evaporator temperature is same as room temperature throughout, that is, degree of superheat  $\Delta T_s$  is zero. If the power fluid is the same as the refrigerant, then  $P_p = P_e$  and  $F_p = F_e$ . Therefore any arbitrarily small spring force  $F_s$  acting upwards will push the needle stand against the orifice and keep the TEV closed. If it is *TEV with cross charge* or if there is a little degree of

superheat during off-cycle then for TEV to remain closed during off-cycle,  $F_s$  should be slightly greater than  $(F_p - F_e)$ .



**Fig.24.13:** Schematic of a Thermostatic Expansion Valve (TEV)

As the compressor is started, the evaporator pressure decreases at a very fast rate hence the force  $F_e$  decreases at a very fast rate. This happens since TEV is closed and no refrigerant is fed to evaporator while compressors draws out refrigerant at a very fast rate and tries to evacuate the evaporator. The force  $F_p$  does not change during this period since the evaporator temperature does not change. Hence, the difference  $F_p - F_e$ , increases as the compressor runs for some time after starting. At one point this difference becomes greater than the spring force  $F_s$  and pushes the needle stand downwards opening the orifice. The valve is said to open up. Since a finite downward force is required to open the valve, a minimum degree of superheat is required for a finite mass flow rate.

As the refrigerant enters the evaporator it arrests the fast rate of decrease of evaporator pressure. The movement of needle stand also slows down. The spring, however gets compressed as the needle stand moves downward to open

the orifice. If  $F_{s0}$  is the spring force in the rest position, that is, off-cycle, then during open valve position

$$F_s = F_{s0} + \Delta F_s$$

Eventually, the needle stand reaches a position such that,

$$F_s = F_p - F_e = A_b (P_p - P_e) \quad (24.29)$$

That is,  $F_p$  is greater than  $F_e$  or  $P_p$  is greater than  $P_e$ . The pressure  $P_p$  and  $P_e$  are saturation pressures at temperature  $(T_e + \Delta T_s)$  and  $T_e$  respectively. Hence, for a given setting force  $F_s$  of the spring, TEV maintains the difference between  $F_p$  and  $F_e$  or the degree of superheat  $\Delta T_s$  constant.

$$\begin{aligned} \Delta T_s &\propto (F_p - F_e) \\ &\propto F_s \end{aligned} \quad (24.30)$$

This is irrespective of the level of  $P_e$ , that is, evaporator pressure or temperature, although degree of superheat may be slightly different at different evaporator temperatures for same spring force,  $F_s$ . It will be an ideal case if the degree of superheat is same at all evaporator temperatures for a given spring force.

#### 24.5.1. Effect of Load Variation

If the load on the plant increases, the evaporation rate of liquid refrigerant increases, the area available for superheating the vapour increases. As the degree of superheat increases, pressure of power fluid  $P_p$  increases, the needle stand is pushed down and the mass flow rate of refrigerant increases. This is the ideal case. The evaporation rate of refrigerant is proportional to the load and the mass flow rate supplied through the expansion valve is also proportional to the load.

On the other hand, if the load on the plant decreases, the evaporation rate of refrigerant decreases, as a result the degree of superheat decreases. The thermostatic expansion valve reacts in such a way so as to reduce the mass flow rate through it. The flow rate of refrigerant in this valve is proportional to the evaporation rate of refrigerant in the evaporator. Hence, this valve always establishes balanced flow condition of flow between compressor and itself.

#### 24.5.2. TEV with cross charge

Figure 24.14 shows the saturated vapour line with pressure along the ordinate. The difference between  $P_p$  and  $P_e$  is proportional to the spring force,  $F_s$  and their corresponding projection from the saturated vapour line is the degree of superheat given by a set of  $P_p$  and  $P_e$ . The figure shows three sets of  $P_p$  and  $P_e$

for the same spring force at three evaporator temperatures say  $-40^{\circ}\text{C}$ ,  $-20^{\circ}\text{C}$  and  $5^{\circ}\text{C}$ . It is observed that at location A, the degree of superheat is very large whereas at location C the degree of superheat is very small for the same spring force setting proportional to  $(P_p - P_e)$ . This would not have been the case if the saturated vapour line was a straight line. It is observed that if the spring is set for say a superheat of  $10^{\circ}\text{C}$  at  $-40^{\circ}\text{C}$  evaporator temperature, the degree of superheat will become almost zero at higher temperature (Fig.24.14). As a result; when the plant is started at warm temperature, there is a possibility of flooding of evaporator. If degree of superheat is set to avoid flooding at say  $5^{\circ}\text{C}$ , then at the design point of say  $-40^{\circ}\text{C}$ , the superheat will be very large and it will starve the evaporator. This can be corrected if a fluid different from refrigerant is used in the feeler bulb as power fluid. Such a TEV is called *TEV with cross charge*. Figure 24.15 shows the saturated vapour line for the power fluid as well as the refrigerant in the system. The projection for  $P_p$  is taken from the saturation line for power fluid and it shows the temperature at the exit of the evaporator. The power fluid is such that at any temperature it has lower saturation pressure than that of the refrigerant in the system, so that as the evaporator temperature increases the degree of superheat increases. The projection for  $P_e$  is taken from the saturation line of refrigerant and it indicates the evaporator temperature. It is observed that for the two different locations A and B, the degree of superheat is almost same for all evaporator temperatures. Hence cross charge helps in maintaining the same degree of superheat at all evaporator temperatures. Cross-charged valves perform satisfactorily in a narrow range of temperatures that must be specified while ordering a valve.

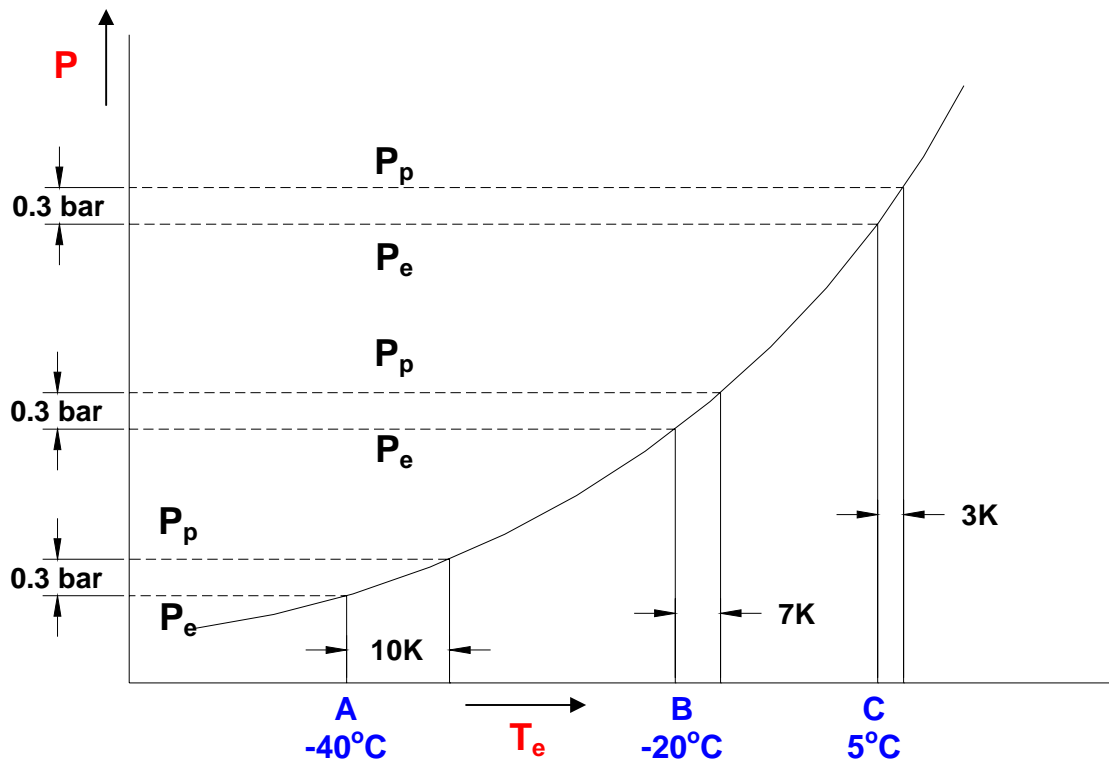
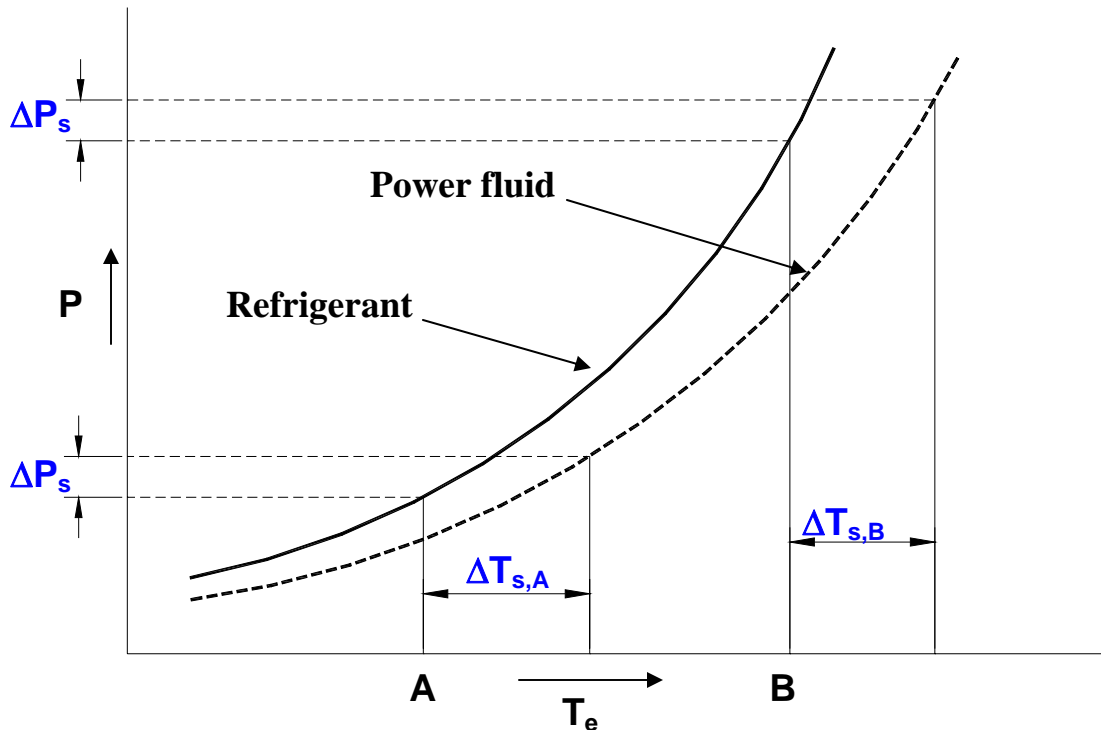


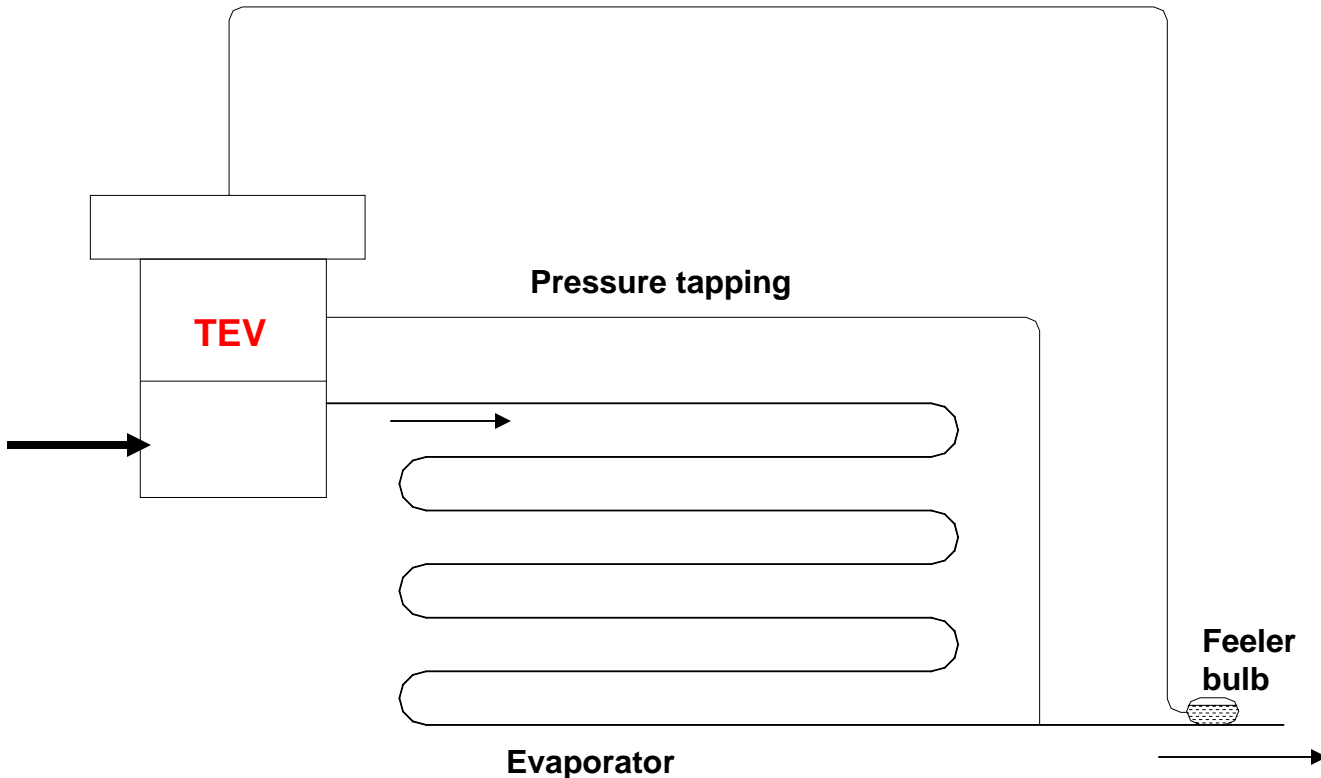
Fig.24.14: Vapour pressure curve of refrigerant and power fluid



**Fig.24.15:** Vapour pressure curves of refrigerant and power fluid (cross-charged TEV)

### 24.5.3. TEV with External Pressure Equalizer

The pressure drop of the refrigerant is quite significant in large evaporators, for example in direct expansion coils with a single long tube. Thermostatic expansion valve maintains  $F_p - F_e = A_b(P_p - P_e)$  at a constant value equal to spring force. The pressure  $P_p$  is the saturation pressure at  $(T_e + \Delta T_s)$  while  $P_e$  is saturation pressure at  $T_e$ . In a large evaporator, due to pressure drop  $\Delta P_e$ , the pressure at exit is say,  $P_e - \Delta P_e$  and corresponding saturation temperature at exit of evaporator is  $T_e - \Delta T_e$ . The superheat  $\Delta T_s$  corresponds to evaporator pressure  $P_e$  and temperature  $T_e$ . Therefore, effective superheat at evaporator exit is  $\Delta T_s + \Delta T_e$ . This may become very large and may result in low COP and lower volumetric efficiency of compressor. To correct for this, TEV is provided with a tapping, which feeds the pressure  $P_e - \Delta P_e$  from evaporator exit to the bottom of bellows. This will result in a degree of superheat equal to the set value  $\Delta T_s$ . A TEV with this provision is called *TEV with External Pressure Equalizer*. In this TEV a stuffing box is provided between pushpins and the valve body so that evaporator inlet pressure is not communicated to the bottom of bellows. Figure 24.16 shows a TEV with an external equalizer arrangement with pressure tapping.



**Fig.24.16:** A Thermostatic Expansion Valve with an external equalizer

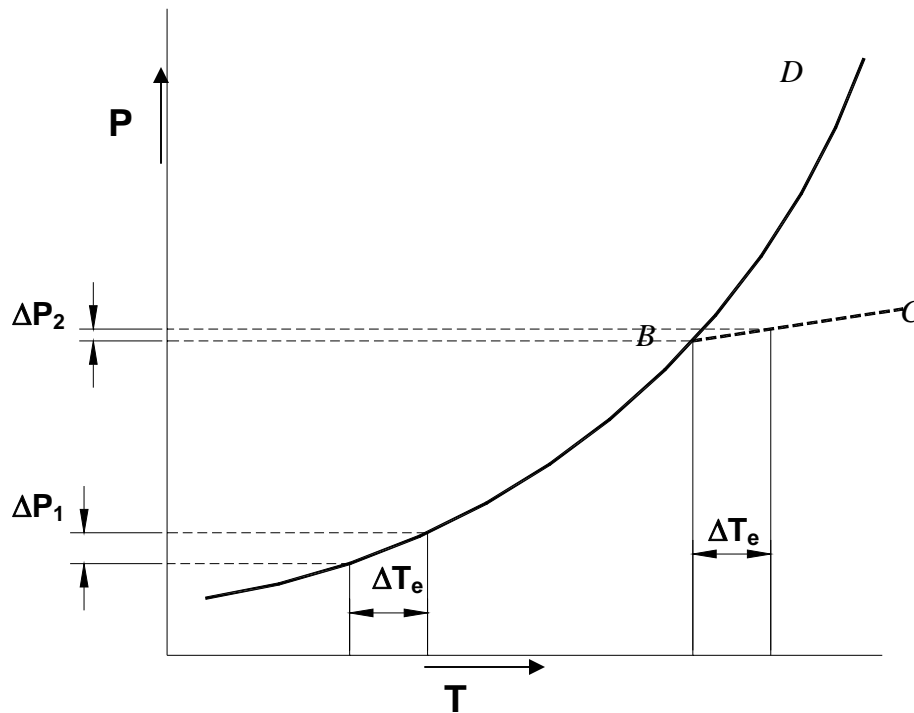
In any case a large evaporator pressure drop leads to a lower COP; hence a number of parallel paths or circuits are provided in the evaporator. The refrigerant is fed to these paths by a single TEV fitted with a distributor. In such a case, it is recommended that external pressure equalizer be used and care taken to ensure that all the paths are symmetric and have the same length.

#### **24.5.4. Fade-out point and pressure limiting characteristics of TEV:**

The volume of power fluid in the feeler bulb and the connecting tube is constant, therefore heating and cooling of power fluid is a constant specific volume process. Figure 24.17 shows the pressure-temperature variation of the power fluid. The bulb usually has a mixture of liquid and vapour and the pressure exerted by power fluid corresponds to its saturation pressure. The pressure of the power fluid increases rather rapidly as its temperature increases since the liquid evaporates and it has to be accommodated in fixed volume. This sharp rise in pressure with temperature continues until point *B* on the saturation curve, where no liquid is left. Since the pressure of the power fluid does not increase significantly beyond *B*, the valve does not open any wider,  $p_p \approx \text{constant}$ , hence for a fixed spring setting  $p_e$  remains almost constant and thereby limits the pressure in the evaporator to *Maximum Operating pressure*. It was observed in an earlier lecture on reciprocating compressors that the power requirement of a reciprocating compressor is maximum at a certain evaporator pressure. The air-conditioning systems usually operate near the peak while the refrigeration systems such as those for ice cream or frozen food operate on the left side of the

peak power. It was shown that during pull-down, the power requirement would pass through the power peak if the evaporator were kept fully supplied with liquid. It is however uneconomical to provide a large electric motor to meet the power requirement of the peak for small times during pull-down. The power requirement at the design point on the left leg is small. A motor capable of providing normal power can be used if the TEV makes the evaporator starve (reduces mass flow rate to it) and limits the pressure during pull-down when the load is high. Charging the bulb with limited mass of power fluid so that it is entirely vapour above a maximum evaporating pressure and temperature achieves this purpose. If rapid cooling is required from the refrigeration system then this cannot be used.

The limit charged valve is prone to failure known as *reversal*. The feeler bulb has vapour only. The head of the feeler bulb is usually colder than the rest of it, as a result a small amount of vapor can condense in this region. This colder region will have lower saturation pressure that will decide the pressure of the feeler bulb and this low pressure may be insufficient to open the valve. This is avoided by keeping the head of the valve warm by internal circulation.



**Fig.24.17:** Variation of power fluid pressure with temperature in a limit charged TEV

#### 24.4.5. Advantages, disadvantages and applications of TEV

The advantages of TEV compared to other types of expansion devices are:

1. It provides excellent control of refrigeration capacity as the supply of refrigerant to the evaporator matches the demand
2. It ensures that the evaporator operates efficiently by preventing starving under high load conditions
3. It protects the compressor from slugging by ensuring a minimum degree of superheat under all conditions of load, if properly selected.

However, compared to capillary tubes and AEVs, a TEV is more expensive and proper precautions should be taken at the installation. For example, the feeler bulb must always be in good thermal contact with the refrigerant tube. The feeler bulb should preferably be insulated to reduce the influence of the ambient air. The bulb should be mounted such that the liquid is always in contact with the refrigerant tubing for proper control.

The use of TEV depends upon degree of superheat. Hence, in applications where a close approach between the fluid to be cooled and evaporator temperature is desired, TEV cannot be used since very small extent of superheating is available for operation. A counter flow arrangement can be used to achieve the desired superheat in such a case. Alternately, a subcooling HEX may be used and the feeler bulb mounted on the vapour exit line of the HEX. The valves with bellows have longer stroke of the needle, which gives extra sensitivity compared to diaphragm type of valve. But valves with bellows are more expensive.

Thermostatic Expansion Valves are normally selected from manufacturers' catalogs. The selection is based on the refrigeration capacity, type of the working fluid, operating temperature range etc. In practice, the design is different to suit different requirements such as single evaporators, multi-evaporators etc.

#### 24.6. Float type expansion valves:

Float type expansion valves are normally used with flooded evaporators in large capacity refrigeration systems. A float type valve opens or closes depending upon the liquid level as sensed by a buoyant member, called as float. The float could take the form of a hollow metal or plastic ball, a hollow cylinder or a pan. Thus the float valve always maintains a constant liquid level in a chamber called as float chamber. Depending upon the location of the float chamber, a float type expansion valve can be either a low-side float valve or a high-side float valve.

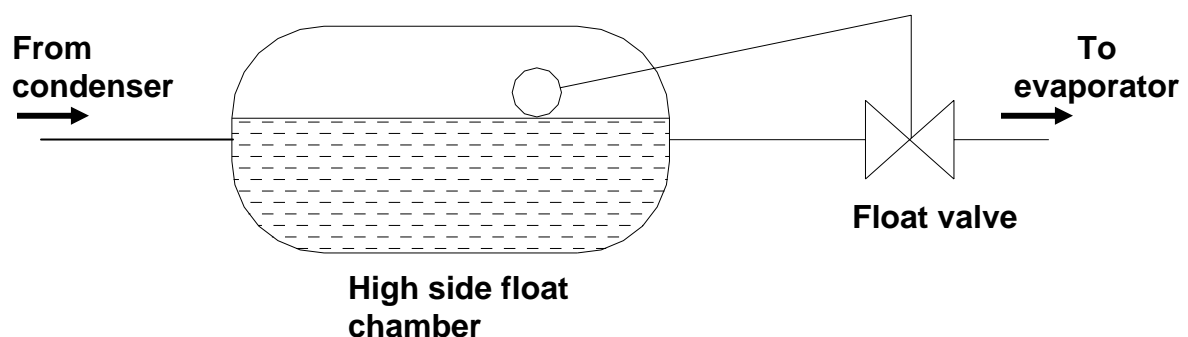


### 24.6.1. Low-side float valves:

A low-side float valve maintains a constant liquid level in a flooded evaporator or a float chamber attached to the evaporator. When the load on the system increases, more amount of refrigerant evaporates from the evaporator. As a result, the refrigerant liquid level in the evaporator or the low-side float chamber drops momentarily. The float then moves in such a way that the valve opening is increased and more amount of refrigerant flows into the evaporator to take care of the increased load and the liquid level is restored. The reverse process occurs when the load falls, i.e., the float reduces the opening of the valve and less amount of refrigerant flows into the evaporator to match the reduced load. As mentioned, these valves are normally used in large capacity systems and normally a by-pass line with a hand-operated expansion is installed to ensure system operation in the event of float failure.

### 24.6.2. High-side float valves:

Figure 24.18 shows the schematic of a high-side float valve. As shown in the figure, a high-side float valve maintains the liquid level constant in a float chamber that is connected to the condenser on the high pressure side. When the load increases, more amount of refrigerant evaporates and condenses. As a result, the liquid level in the float chamber rises momentarily. The float then opens the valve more to allow a higher amount of refrigerant flow to cater to the increased load, as a result the liquid level drops back to the original level. The reverse happens when the load drops. Since a high-side float valve allows only a fixed amount of refrigerant on the high pressure side, the bulk of the refrigerant is stored in the low-pressure side (evaporator). Hence there is a possibility of flooding of evaporator followed by compressor slugging. However, unlike low-side float valves, a high-side float valve can be used with both flooded as well as direct expansion type evaporators.



**Fig.24.18:** Schematic of a high-side float valve

## 24.7. Electronic Type Expansion Valve

The schematic diagram of an electric expansion valve is shown in Fig.24.19. As shown in the figure, an electronic expansion valve consists of an orifice and a needle in front it. The needle moves up and down in response to magnitude of current in the heating element. A small resistance allows more current to flow through the heater of the expansion valve, as a result the valve opens wider. A small negative coefficient thermistor is used if superheat control is desired. The thermistor is placed in series with the heater of the expansion valve. The heater current depends upon the thermistor resistance that depends upon the refrigerant condition. Exposure of thermistor to superheated vapour permits thermistor to selfheat thereby lowering its resistance and increasing the heater current. This opens the valve wider and increases the mass flow rate of refrigerant. This process continues until the vapour becomes saturated and some liquid refrigerant droplets appear. The liquid refrigerant will cool the thermistor and increase its resistance. Hence in presence of liquid droplets the thermistor offers a large resistance, which allows a small current to flow through the heater making the valve opening narrower. The control of this valve is independent of refrigerant and refrigerant pressure; hence it works in reverse flow direction also. It is convenient to use it in year-round-air-conditioning systems, which serve as heat pumps in winter with reverse flow. In another version of it the heater is replaced by stepper motor, which opens and closes the valve with a great precision giving a proportional control in response to temperature sensed by an element.

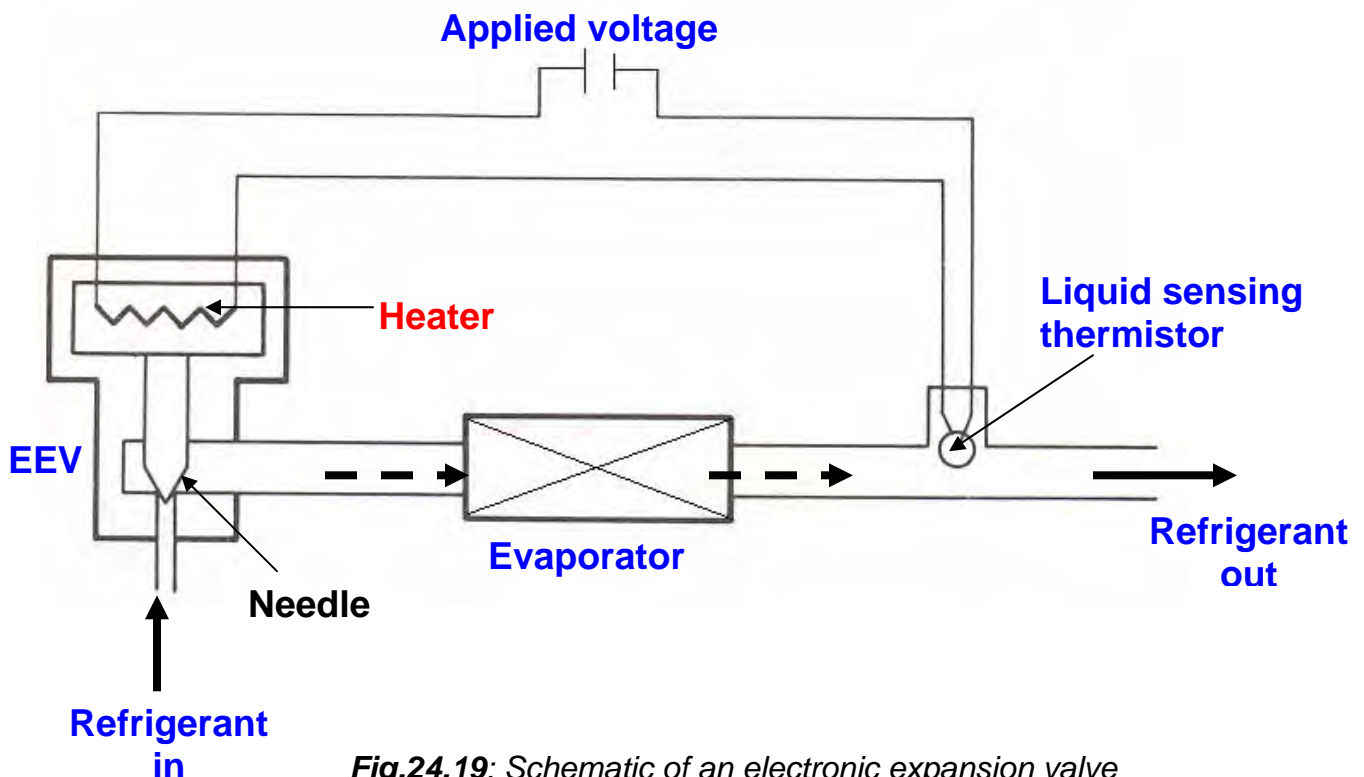


Fig.24.19: Schematic of an electronic expansion valve

## 24.8. Practical problems in operation of Expansion valves

Certain practical problems are encountered with expansion devices if either the selection and/or its operation are not proper. An oversized expansion device will overfeed the refrigerant or hunt (too frequent closing and opening) and not achieve the balance point. It may allow more refrigerant to flow to the evaporator and cause flooding and consequent slugging of the compressor with disastrous results.

A small valve on the other hand passes insufficient quantity of the refrigerant so that balance point may occur at a lower temperature. The mass flow rate through the expansion valve depends upon the pressure difference between condenser and evaporator. The condenser temperature and consequently the pressure decrease during winter for air-cooled as well as water-cooled condensers. As a result, the pressure difference is not sufficient for balance of flow between compressor and the expansion valve. Hence, the evaporator temperature and pressure decrease during winter months. This decreases the volumetric efficiency of the compressor and results in lower mass flow rate and lower cooling capacity. This may lead to disastrous results for hermetic compressors, which rely upon refrigerant flow rate for cooling of motor. At lower mass flow rates hermetic compressor may not be cooled sufficiently and may burn out. Hence, sometimes the condenser pressure must be kept artificially high so that adequate supply of refrigerant is achieved. Thus the natural advantage of lower condenser pressure is lost due to the need for maintaining the condenser pressure artificially high for proper functioning of the expansion device.

During summer months, the mass flow rate through expansion valve is large because of large pressure difference. The corrective action taken by the system is to pass vapour through the expansion valve. This problem can occur if there is insufficient charge of refrigerant in the system so that the liquid seal at condenser exit is broken and vapour enters the expansion valve. It can occur because of higher elevation of expansion valve over the condenser so that there is static pressure drop to overcome gravitational force to reach the expansion valve, which causes flashing of refrigerant into a mixture of liquid and vapour. This is however not advisable since it leads to lower COP. Hence, it is advisable to use a liquid to vapour subcooling heat exchanger so that the liquid is subcooled and will not flash before entry into expansion valve.

Since the area available for refrigerant flow in the expansion device is normally very small, there is a danger of valve blockage due to some impurities present in the system. Hence, it is essential to use a filter/strainer before the expansion device, so that only refrigerant flows through the valve and solid particles, if any, are blocked by the filter/strainer. Normally, the automatic expansion valve and thermostatic expansion valves consist of in-built filter/strainers. However, when a capillary tube is used, it is essential to use a

filter/dryer ahead of the capillary to prevent entry of any solid impurities and/or unbound water vapour into the capillary tube.

## Questions and answers:

1. Which of the following statements are TRUE?

- a) A capillary tube is a variable opening area type expansion device
- b) In a capillary tube pressure drop takes place due to fluid friction
- c) In a capillary tube pressure drop takes place due to fluid acceleration
- d) In a capillary tube pressure drop takes place due to fluid friction and acceleration

**Ans.: d)**

2. Which of the following statements are TRUE?

- a) The refrigerant mass flow rate through a capillary tube increases as condenser pressure decreases and evaporator pressure increases
- b) The refrigerant mass flow rate through a capillary tube increases as condenser pressure increases and evaporator pressure decreases
- c) A capillary tube tends to supply more mass flow rate as refrigeration load increases
- d) A capillary tube tends to supply more mass flow rate as refrigeration load decreases

**Ans.: b) and d)**

3. Which of the following statements are TRUE?

- a) A capillary tube based refrigeration system is a critically charged system
- b) A capillary tube based refrigeration system does not use a receiver
- c) Capillary tube based refrigeration systems employ open type compressors
- d) In capillary tube based systems, pressure equalization takes place when compressor is off

**Ans.: a), b) and d)**

4. Which of the following statements are TRUE?

- a) The mass flow rate through a capillary is maximum under choked flow conditions
- b) The mass flow rate through a capillary is minimum under choked flow conditions
- c) The enthalpy of refrigerant remains constant as it flows through a capillary tube

d) The enthalpy of refrigerant in a capillary tube decreases in the flow direction

**Ans.: a) and d)**

5. For a given refrigerant mass flow rate, the required length of a capillary tube increases as:

- a) The degree of subcooling at the inlet decreases
- b) The diameter of the capillary tube increases
- c) The diameter of capillary tube decreases
- d) Inlet pressure increases

**Ans.: b) and d)**

6. Which of the following statements are TRUE?

- a) An automatic expansion valve maintains a constant pressure in the condenser
- b) An automatic expansion valve maintains a constant pressure in the evaporator
- c) In an automatic expansion valve, the mass flow rate of refrigerant increases as the refrigeration load increases
- d) Automatic expansion valve based systems are critically charged

**Ans.: b) and d)**

7. A thermostatic expansion valve:

- a) Maintains constant evaporator temperature
- b) Maintains a constant degree of superheat
- c) Increases the mass flow rate of refrigerant as the refrigeration load increases
- d) Prevents slugging of compressor

**Ans.: b), c) and d)**

8. Which of the following statements are TRUE?

- a) Cross-charging is used in TEV when the pressure difference across the evaporator is large
- b) Cross-charging is used in TEV when the evaporator has to operate over a large temperature range
- c) An external equalizer is used when pressure drop in evaporator is large
- d) By limiting the amount of power fluid, the power peak during pull-down period can be avoided

**Ans.: b), c) and d)**

9. Which of the following statements are TRUE?

- a) A float valve maintains a constant level of liquid in the float chamber
- b) A float valve maintains a constant pressure in the float chamber
- c) Low-side float valves are used with direct expansion type evaporators
- d) High-side float valves are used in flooded type evaporators

**Ans.: a)**

10. Which of the following statements are TRUE?

- a) An electronic expansion valve is bi-directional
- b) In an electronic expansion valve, the refrigerant mass flow rate increases as the amount of liquid at evaporator exit increases
- c) In an electronic expansion valve, the refrigerant mass flow rate increases as the temperature of refrigerant at evaporator exit increases
- d) Electronic expansion valves are used in all-year air conditioning systems

**Ans.: a), c) and d)**

11. A thermostatic expansion valve uses R12 as the power fluid, and is used in a R12 based system operating at an evaporator temperature of 4°C. The adjustable spring is set to offer a resistance equivalent to a pressure of 60 kPa. What is the degree of superheat?

**Ans.:** From the properties of R12, at 4°C, the saturation pressure  $P_e$  is **350 kPa**.

Hence the pressure acting on the bellows/diaphragm due to the power fluid  $P_p$  is:

$$P_p = P_e + P_s = 350 + 60 = 410 \text{ kPa}$$

The saturation temperature corresponding to a pressure of 410 kPa is **9°C**

**Hence the degree of superheat = 9 – 4 = 5°C (Ans.)**

12. For the above thermostat, what is the actual degree of superheat if there is a pressure drop of 22 kPa in the evaporator?

**Ans.:** The pressure of refrigerant at the exit of evaporator,  $P_{e,exit}$  is:

$$P_{e,exit} = P_{e,inlet} - \Delta P_e = 350 - 22 = 328 \text{ kPa}$$

The saturation temperature corresponding to 328 kPa is: **1.9°C**

**Hence the actual degree of superheat = 9 – 1.9 = 7.1°C (Ans.)**

This implies that a TEV with external equalizer is preferable to reduce the superheat

**13.** A straight-charged Thermostatic Expansion Valve (TEV) is designed to operate at an evaporator temperature of  $7^{\circ}\text{C}$  with a degree of superheat of **5 K**. R 134a is the refrigerant used in the refrigeration system as well as the bulb. Find a) The required spring pressure at the design condition; b) Assuming the spring pressure to remain constant, find the degree of superheat, if the same TEV operates at an evaporator temperature of  $-23^{\circ}\text{C}$ . The saturation pressure of R134a can be estimated using Antoine's equation given by:

$$p_{\text{sat}} = \exp\left(14.41 - \frac{2094}{T - 33.06}\right) \quad \text{where } p_{\text{sat}} \text{ is in kPa and } T \text{ is in K}$$

**Ans.:** At the design conditions the evaporator temperature is  $7^{\circ}\text{C}$  and degree of superheat is 5 K.

Hence the required adjustable spring pressure,  $P_s$  is:

$$P_s = P_{\text{sat}}(12^{\circ}\text{C}) - P_{\text{sat}}(7^{\circ}\text{C})$$

Using Antoine's equation given above, we find that:

$$P_{\text{sat}}(12^{\circ}\text{C}) = 445.2 \text{ kPa, and}$$

$$P_{\text{sat}}(7^{\circ}\text{C}) = 376.2 \text{ kPa}$$

$$\text{Hence, } P_s = 445.2 - 376.2 = 69 \text{ kPa}$$

If the above TEV is operated at  $-23^{\circ}\text{C}$  evaporator temperature, then the pressure exerted by the power fluid is:

$$P_p = P_{\text{sat}}(-23^{\circ}\text{C}) + P_s = 116.5 + 69 = 185.5 \text{ kPa}$$

The corresponding saturation temperature is  $T_{\text{sat}}(189.5 \text{ kPa}) = 261 \text{ K} = -12^{\circ}\text{C}$

**Hence the degree of superheat at  $-23^{\circ}\text{C} = -12 - (-23) = 13 \text{ K}$  (Ans.)**

This example shows that when the same TEV operates at a lower evaporator temperature, then the required degree of superheat increases implying improper utilization of evaporator area. Hence, it is better to use cross-charging (power fluid is another fluid with a higher boiling point than refrigerant).

# Lesson

25

## Analysis Of Complete Vapour Compression Refrigeration Systems



## The specific objectives of this lecture are to:

1. Importance of complete vapour compression refrigeration system analysis and the methods used (*Section 25.1*)
2. Performance characteristics of reciprocating compressors (*Section 25.2*)
3. Performance characteristics of reciprocating condensers (*Section 25.3*)
4. Performance characteristics of evaporators (*Section 25.4*)
5. Performance characteristics of expansion valves (*Section 25.5*)
6. Performance characteristics of condensing unit (*Section 25.6*)
7. Performance characteristics of complete system by matching characteristics of evaporator and condensing unit (*Section 25.7*)
8. Effect of expansion valve on complete system performance (*Section 25.8*)
9. Meaning of sensitivity analysis (*Section 25.9*)

At the end of the lecture, the student should be able to:

1. Explain the concept of complete system analysis and the characteristics of graphical and analytical methods
2. Express or plot the performance characteristics of individual components such as compressors, condensers and evaporators and enumerate the influence of operating parameters such as cooling water and brine flow rates, inlet temperatures etc.
3. Obtain balance point for a condensing unit by matching the characteristics of compressors and condensers
4. Obtain the balance point and characteristics curves for a complete system assuming an ideal expansion valve
5. Explain the effect of expansion device on system performance
6. Explain the meaning of sensitivity analysis and its importance in system design and optimization

## 25.1. Introduction

A basic vapour compression refrigeration system consists of four essential components, namely compressor, condenser, expansion valve and evaporator. The individual performance characteristics of these components have been discussed in earlier lectures. However, in an actual system these components work in unison. The performance of a complete system is a result of the balance between these four components. For example, when the heat sink temperature varies, it affects the performance of the condenser, which in turn, affects the performance of the expansion device, evaporator and the compressor.

It is seen in Chapter 24 that expansion valve and compressor work in such a manner that the mass flow rate through the two components is the same at steady state. The balance point at steady state was obtained by equating the mass flow rates through these components. This is an example of balancing two components. Similar procedure can be extended to include the other two components also, so that a balance point for the entire system can be obtained by taking into account the individual characteristics. In principle, the balance point for the system can be obtained either by a graphical method or by an analytical method.

In graphical method, the performance of two interdependent components is plotted for the same two variables of common interest. For example, mass flow rate and evaporator temperature (or pressure) are plotted along  $y$  and  $x$  axes respectively for combination of compressor – expansion device at constant condenser temperature. The point of intersection of the two resulting curves will indicate the conditions at which the mass flow rate and evaporator temperature will be same for the two components. This point is called the balance point and in steady-state the combination will achieve these conditions.

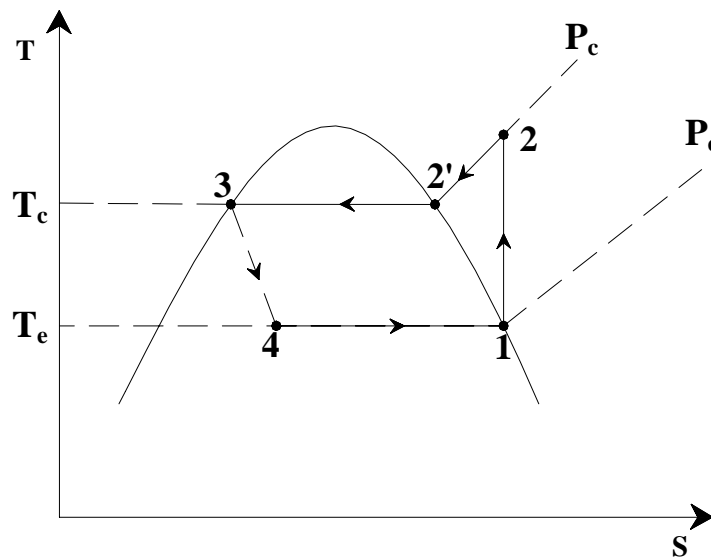
In analytical method, the mass flow rate through expansion valve can be represented by an algebraic equation in terms of evaporator and condenser temperatures. Similarly, the mass flow rate through a given compressor can also be represented by an algebraic equation in terms of evaporator and condenser temperatures by regression analysis of experimental or analytical data. The balance point of the two components can be obtained by simultaneous solution of the two algebraic equations.

Since the graphical method uses two-dimensional plots, it considers only two components at a time while the system analysis by mathematical means can consider more than two components simultaneously. Further, considering time variation of parameters in form of differential equations can simulate the dynamic performance also. Steady-state system analysis will involve simultaneous solution of algebraic equations.

In this chapter, balance points of condensing unit, compressor-evaporator combination have been considered for illustration. As a first step the performance data of industrial components is presented in the form of plots or equations. The raw data for this purpose can be obtained from the catalogues of manufacturers. These are plotted either directly or after processing in terms of required variables.

## 25.2. Reciprocating compressor performance characteristics:

The power requirement and mass flow rate as function of evaporator temperature with condenser temperature as a parameter were presented in the chapter on compressors. For the purpose of balancing, the refrigeration capacity is required as a function of evaporator and condenser temperatures. This can be easily determined by considering the refrigeration cycle or from the catalogue data of the manufacturer. Figure 25.1 shows a theoretical single stage saturated cycle on T-s chart.



**Fig.25.1:** A single stage, saturated vapour compression refrigeration cycle

For the above cycle, the refrigeration capacity and power input to compressor are given by:

$$\dot{Q}_e = \dot{m}_r (h_1 - h_4) = \dot{V}_1 \left( \frac{h_1 - h_4}{v_1} \right) \quad (25.1)$$

where  $\dot{Q}_e$  is the refrigeration capacity,  $\dot{m}_r$  and  $\dot{V}_1$  are the refrigerant mass flow rate and volumetric flow rate of refrigerant at compressor inlet, respectively,

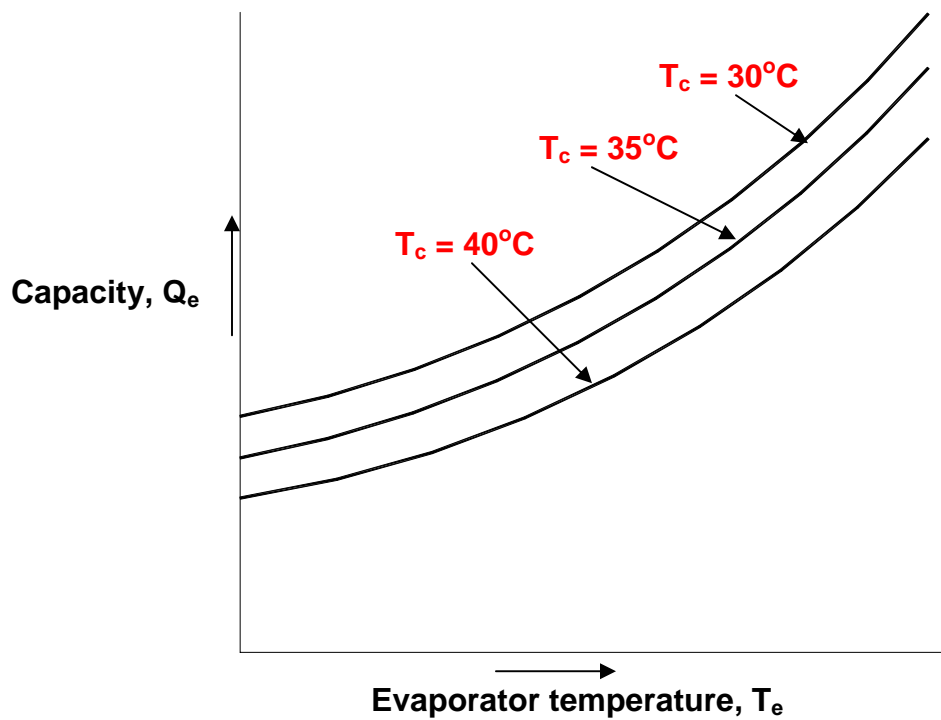
$v_1$  is the specific volume of refrigerant at compressor inlet, and  $h_1$  and  $h_4$  are the enthalpies of refrigerant at the exit and inlet of evaporator.

The volumetric flow rate of a reciprocating compressor is given by:

$$\dot{V}_1 = n \cdot \eta_v \left( \frac{\pi D^2 L}{4} \right) \left( \frac{N}{60} \right) \quad (25.2)$$

where  $n$  is the number of cylinders,  $\eta_v$  is the volumetric efficiency,  $D$ ,  $L$  and  $N$  are the bore, stroke and speed (in RPM) of the compressor, respectively.

It is seen in Chapter 19 that at a given condenser temperature the cooling capacity associated with mass flow rate given by a compressor increases as the evaporator temperature increases. On the other hand, for a given evaporator temperature, the cooling capacity decreases with increase in condenser temperature. These characteristics are shown graphically in Fig.25.2.



**Fig.25.2.** Variation of refrigeration capacity of a reciprocating compressor with evaporator and condenser temperatures at a fixed RPM

The following equation may represent the above trends:

$$Q_e = a_1 + a_2 T_e + a_3 T_e^2 + a_4 T_c + a_5 T_c^2 + a_6 T_e T_c + a_7 T_e^2 T_c + a_8 T_e T_c^2 + a_9 T_e^2 T_c^2 \quad (25.3)$$

where  $T_e$  and  $T_c$  are evaporator and condenser temperatures, respectively. The  $a_1$  to  $a_9$  are constants which can be determined by curve fitting the experimental or manufacturers' data using least square method, or by solving nine simultaneous equations of the type (25.3) for the nine constants  $a_i$  using nine values of  $Q_e$  from given catalogue data for various values of  $T_e$  and  $T_c$ . Similar expression can be obtained for power input to the compressor.

### 25.3. Condenser performance characteristics:

Actual representation of condenser performance can be quite complex as it consists of a de-superheating zone followed by condensing and subcooling zones. The heat transfer coefficient varies continuously along the length of the condenser due to the continuously changing state of the refrigerant. Hence a detailed analysis should include these aspects. However, as discussed in an earlier chapter on condensers, most of the time a simplified procedure is adopted by assuming the temperature to remain constant at a saturated temperature corresponding to the condensing pressure and a constant average condensing heat transfer coefficient is assumed.

For air-cooled condensers, it is possible to represent the total heat rejection rate from the condenser as a function of temperature difference and the overall heat transfer coefficient as follows:

$$Q_c = U_c A_c (T_c - T_\infty) \quad (25.4)$$

where,  $T_\infty$  is the ambient temperature and  $T_c$  is the condensing temperature of refrigerant.

For water-cooled condenser, one has to consider the water flow rate and inlet water temperature as additional parameters. In this case also a single region with constant condenser temperature  $T_c$  is considered. The heat transfer rate for a water-cooled condenser is expressed as follows:

$$Q_c = U_c A_c \text{LMTD} = \dot{m}_w C_{p_w} (T_{w,o} - T_{w,i}) \quad (25.5)$$

where  $\dot{m}_w$  is the water flow rate,  $U_c$  is overall heat transfer coefficient,  $T_{w,i}$  and  $T_{w,o}$  are the inlet and outlet water temperatures respectively. The log mean temperature difference of condenser  $\text{LMTD}_c$  is expressed as follows:

$$\text{LMTD}_c = \frac{T_{w,o} - T_{w,i}}{\ln \left\{ \frac{T_c - T_{w,i}}{T_c - T_{w,o}} \right\}} \quad (25.6)$$

From Eqns.(25.5) and (25.6) it can easily be shown that:

$$T_{w,o} = T_c - (T_c - T_{w,i}) e^{-\left( \frac{U_c A_c}{\dot{m}_w C_{pw}} \right)} = T_c - (T_c - T_{w,i}) e^{-\text{NTU}} \quad (25.6)$$

NTU is the Number of Transfer Units equal to  $\left( U_c A_c / \dot{m}_w C_{pw} \right)$

The matching or the determination of balance point requires that its characteristics be represented in the same form as done for compressor, that is, cooling capacity vs. evaporator temperature. The condenser by itself does not give cooling capacity. One finds out the condensation rate of liquid refrigerant from the heat rejection capacity of condenser. The condensate rate multiplied by refrigeration capacity gives the cooling capacity. Hence from the given heat rejection capacity  $Q_c$ , one finds the condensate rate  $\dot{m}_{ref}$  for the SSS cycle as follows:

$$\dot{m}_r = Q_c / (h_2 - h_3) \quad (25.7)$$

The corresponding refrigeration of the condenser is given by,

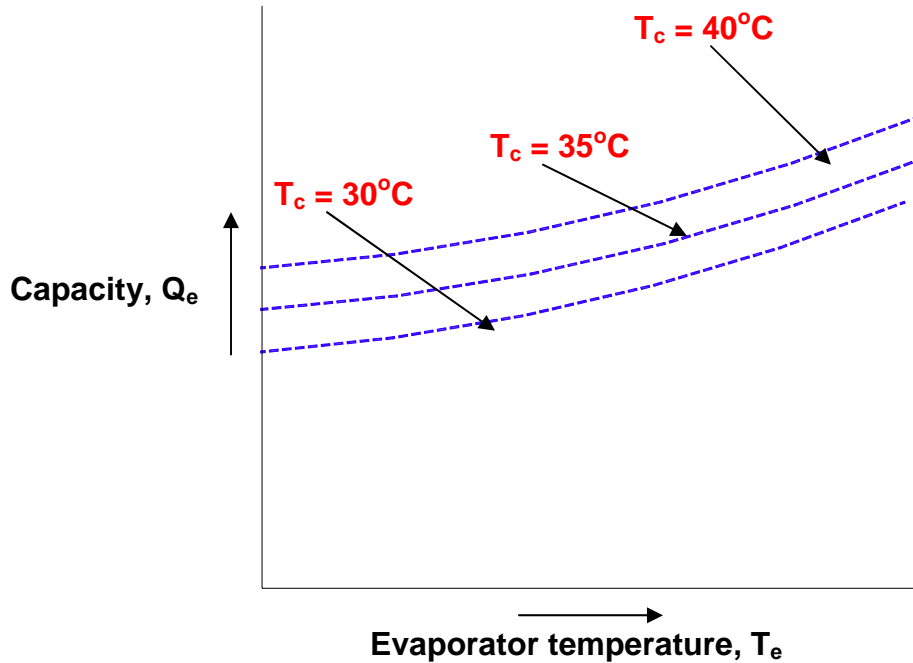
$$Q_e = \dot{m}_r (h_1 - h_4) \quad (25.8)$$

The condenser characteristics are shown in Fig.25.3 for a fixed value of  $\dot{m}_w$  and  $T_{w,i}$ . It is observed that for a fixed evaporator temperature the capacity is higher at higher condenser temperature. A higher condenser temperature leads to a larger value of  $\text{LMTD}_c$ , which in turn gives a larger heat transfer rate and a larger condensate rate.

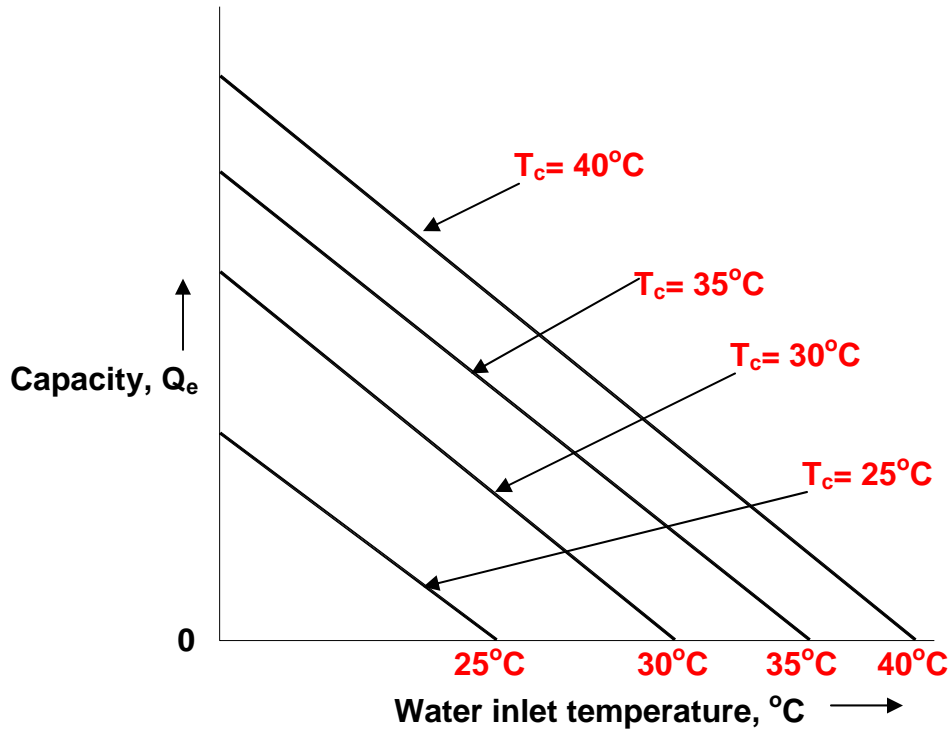
Further it is observed that at fixed condenser temperature, the cooling capacity increases with increase in evaporator temperature. The heat rejection ratio decreases with increase in evaporator temperature hence less heat rejection  $Q_c$  is required per unit cooling capacity, therefore the condensate rate of condenser can give larger cooling capacity. Figure 25.4 shows the effect of entering water temperature  $T_{w,i}$  on cooling capacity for various condenser temperatures. The cooling capacity is zero when the entering water temperature

is equal to condenser temperature. As the inlet water temperature increases for a fixed condenser temperature, the  $LMTD_c$  decreases, which decreases the cooling capacity. The following algebraic equation representing the curves of Fig. 25.3 at constant inlet temperature and flow rate of water can represent these characteristics.

$$Q_e = b_1 + b_2 T_e + b_3 T_e^2 + b_4 T_c + b_5 T_c^2 + b_6 T_e T_c + b_7 T_e^2 T_c + b_8 T_e T_c^2 + b_9 T_e^2 T_c^2 \quad (25.9)$$



**Fig.25.3.** Condenser performance at fixed water inlet temperature and flow rate



**Fig.25.4.** Condenser performance with water inlet temperature at fixed flow rate

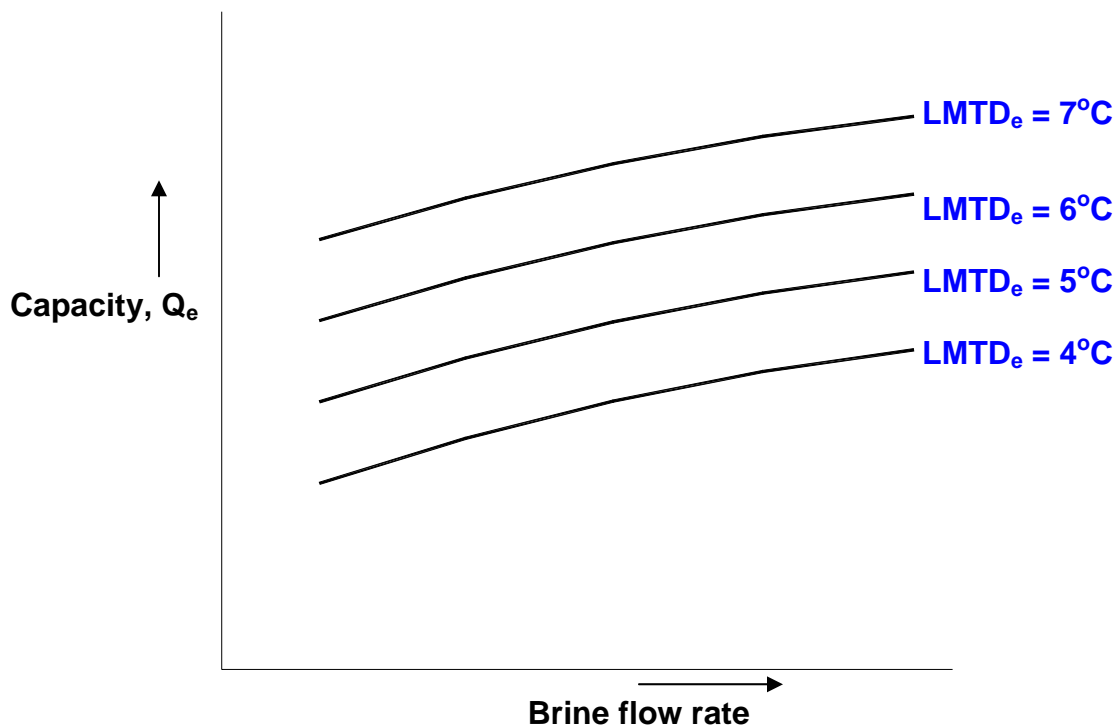
The characteristics in Fig. 25.4 are straight lines with almost same slope for all the condenser temperatures. These may be represented by the following equation with a constant  $G$ .

$$Q_e = G(T_c - T_{w,i}) \quad (25.10)$$



## 25.4. Evaporator Performance

Evaporator is also a heat exchanger just like condenser. For the sake of illustration, consider an evaporator that is used for chilling a brine. The cooling capacity of brine chiller is shown in Fig. 25.5 as a function of brine flow rate for different values of LMTD of evaporator. The brine side heat transfer coefficient  $h_b$  increases as the brine flow rate increases as a result, the overall heat transfer coefficient of the evaporator increases. Figure 25.5 shows that the cooling capacity increases with flow rate for fixed LMTD<sub>e</sub> for this reason.



**Fig.25.5:** Evaporator performance with brine flow rate and LMTD<sub>e</sub>

One can obtain the data for cooling capacity at various brine inlet temperatures from the characteristics of evaporator as shown in Fig.25.5. For example, if a plot for brine inlet temperature  $T_{b,i}$  of 10°C is required, then we may choose an LMTD<sub>e</sub> of 5°C and read the capacity  $Q_e$  for the chosen brine flow rate  $\dot{m}_b$ . Then the brine outlet temperature  $T_{b,o}$  is obtained from the equation:

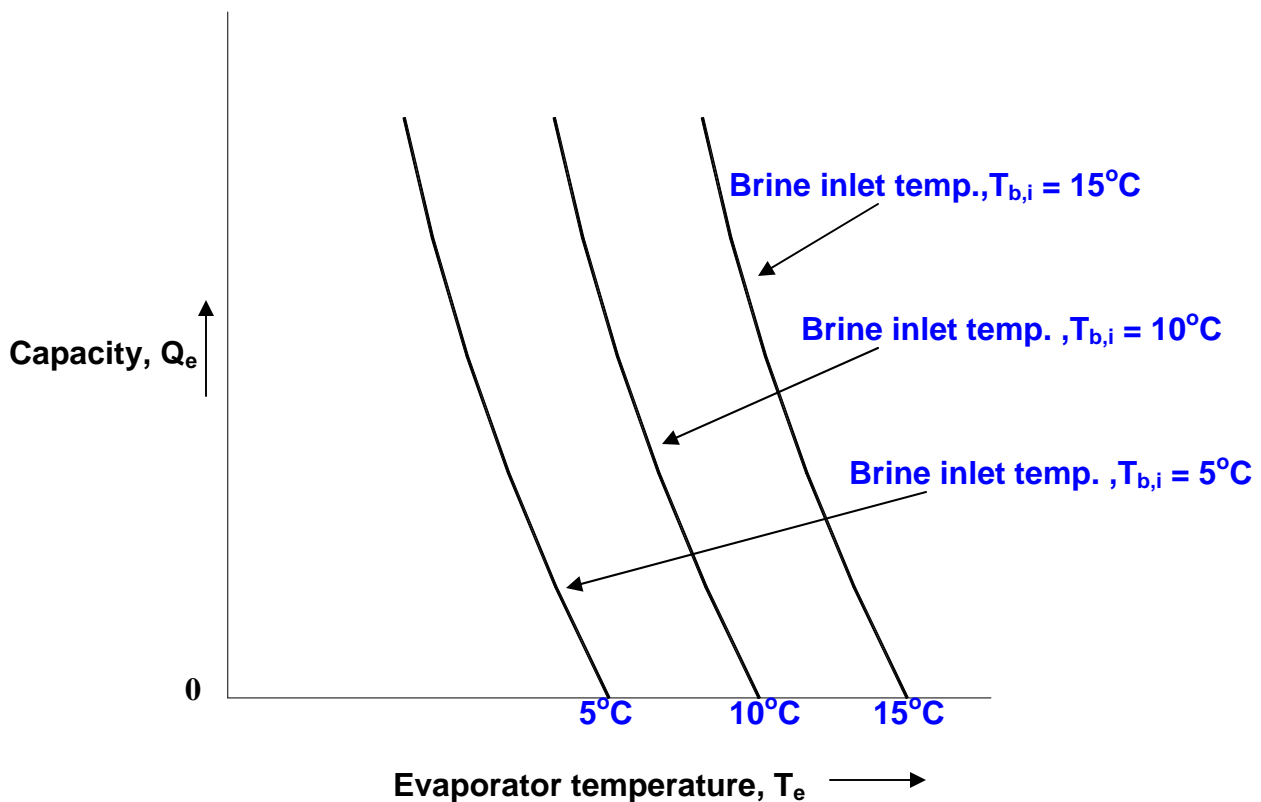
$$Q_e = \dot{m}_b C_{pb} (T_{b,i} - T_{b,o}) \quad (25.11)$$

Then the evaporator temperature  $T_e$  is obtained from the expression for LMTD<sub>e</sub>:

$$\text{LMTD}_e = \frac{T_{b,i} - T_{b,o}}{\ln \left\{ \frac{T_{b,i} - T_e}{T_{b,o} - T_e} \right\}} \quad (25.12)$$

The capacity  $Q_e$  and evaporator temperature  $T_e$  are determined for different values of  $\text{LMTD}_e$  for a fixed brine flow rate and brine inlet temperature of  $10^\circ\text{C}$ . Figure 25.6 shows a plot obtained by this method. In this plot the brine flow rate is constant hence the brine side heat transfer coefficient is constant. If the evaporation heat transfer coefficient was also constant then overall heat transfer coefficient will also be constant and these lines will be straight lines. The evaporation heat transfer coefficient increases with increases in evaporator temperature hence these lines deviate slightly from straight lines. The capacity for these lines may be expressed as follows:

$$Q_e = c_0(T_{b,i} - T_e) + c_1(T_{b,i} - T_e)^2 \quad (25.13)$$



**Fig.25.6:** Performance characteristics of evaporator at fixed brine flow rate

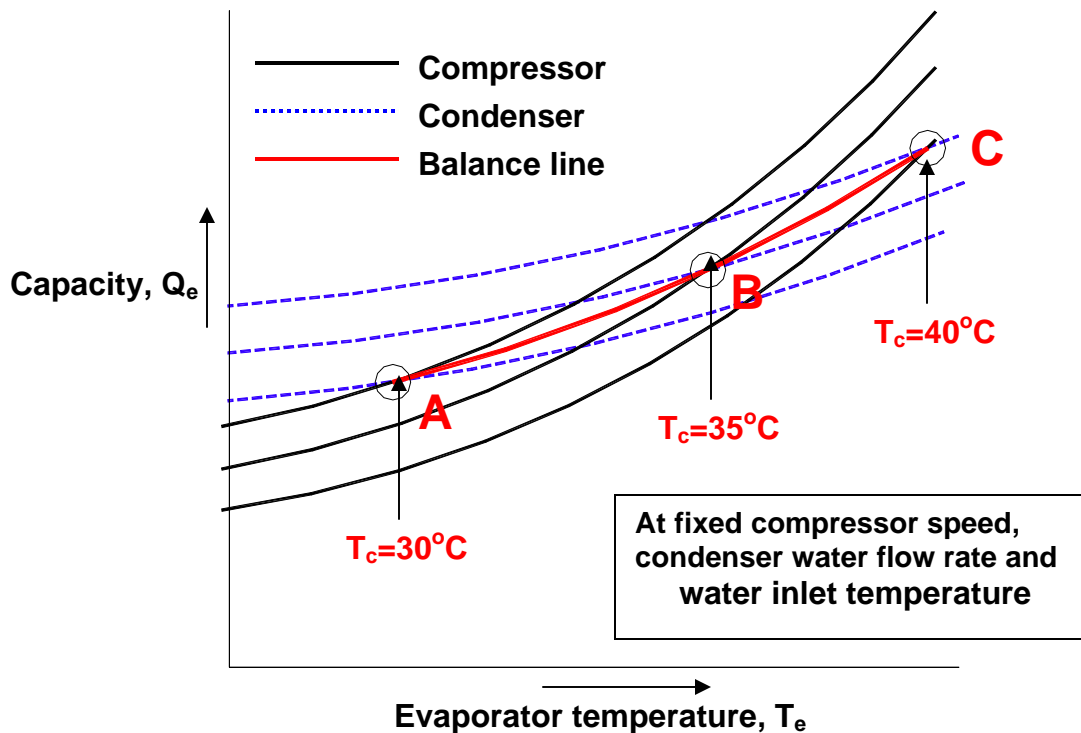
## 25.5. Expansion valve Characteristics:

The characteristics of expansion valve play an important role in deciding the conditions achieved by the refrigeration system. It was shown in Chapter 24 that compressor and expansion valve seek an evaporator temperature such that under steady state conditions, the mass flow rate is same through the compressor and expansion valve. This was the result under the constraint that the condenser and evaporator have sufficiently large heat transfer areas and do not influence the performance of expansion device and compressor. In this chapter it is assumed that the expansion valve is capable of providing sufficient mass flow rate at all condenser and evaporator temperatures. This is assumed to simplify the matching problem. A float type of expansion valve or thermostatic expansion valve will meet this requirement. If the analysis is being done by computational method then the valve performance may also be included with some additional computational effort.

## 25.6. Condensing unit:

As mentioned before, if graphical procedure is used to find performance evaluation of various components, then only two components can be considered at a time. In view of this the first sub-system considered is the condensing unit. Condensing unit is a combination of compressor and condenser. This unit draws refrigerant from the evaporator, compresses it in the compressor, condenses it in the condenser and then feeds the condensed liquid refrigerant to the expansion valve. It is available off-the-shelf as a packaged unit from the manufacturer with matched set of compressor, compressor motor and condenser along with reservoir and controls. This may be air-cooled or water-cooled unit which may be installed as an outdoor unit.

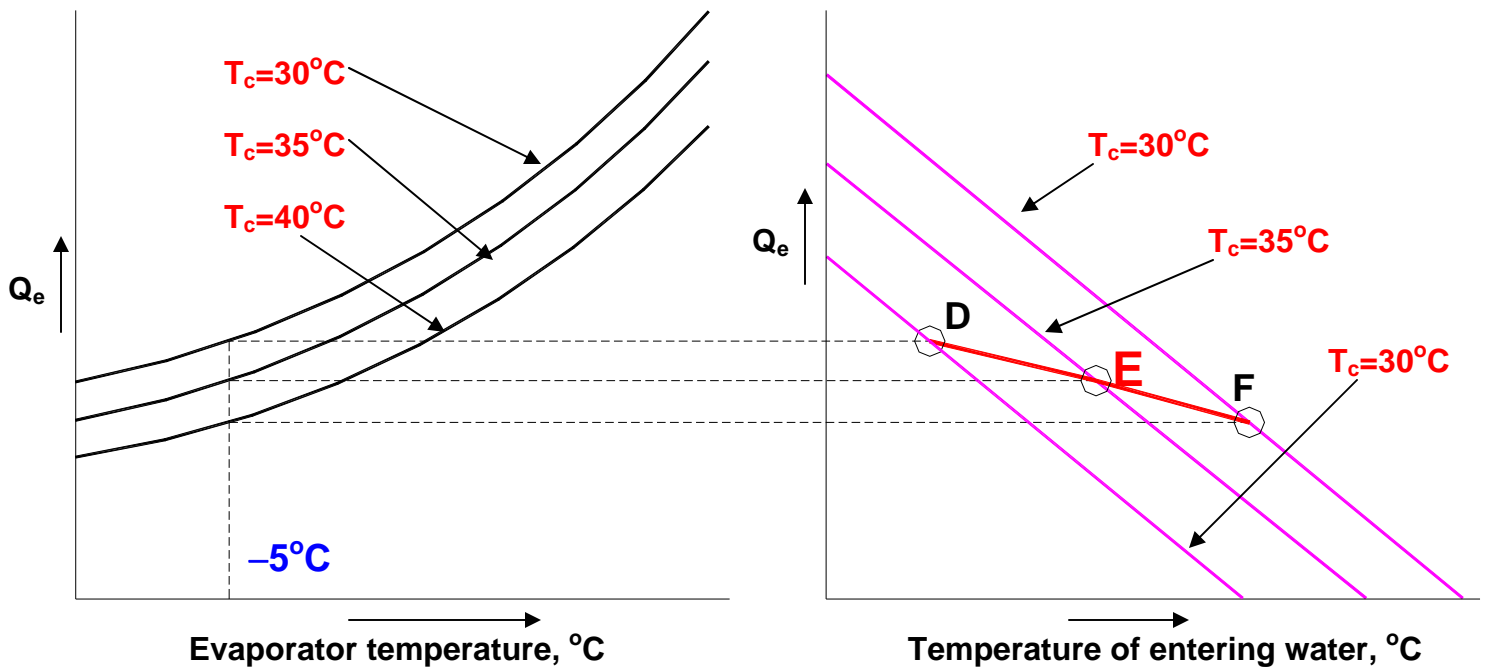
The performance of condensing unit as function of evaporator temperature is obtained by combining the cooling capacity versus evaporator temperature characteristics of compressor and condenser. First we consider cooling capacity versus evaporator temperature assuming the compressor speed, the temperature and mass flow rate and entering water to condenser to be constant. This matching is obtained by superimposing the compressor performance curve given in Fig.25.2 on the condenser performance given in Fig.25.3 as shown in Fig.25.7. The intersection of compressor and condenser characteristics is at point A for 30°C condenser temperature. The combination of compressor and condenser will achieve a cooling capacity and evaporator temperature corresponding to this point at a condensing temperature of 30°C. Similarly, points B and C are the intersections at condenser temperatures of 35 and 40°C, respectively. These points are called balance points and the line A-B-C is called the performance characteristics of the condensing unit.



**Fig.25.7:** Performance characteristics of a condensing unit as a function of evaporator and condensing temperatures

It is observed that as the evaporator temperature decreases, the condensing temperature for the combination also decreases. This is explained as follows: at lower evaporator temperatures, the volumetric efficiency and the mass flow rate through the compressor decreases. This decreases the load on the condenser. A large condenser heat transfer area is available for small mass flow rate, hence condensation can occur at lower condenser temperature. It is also seen that as the evaporator temperature decreases, the refrigeration capacity of the condensing unit also decreases. This is due to the lower mass flow rate through the compressor due to lower volumetric efficiency and lower vapour density at compressor inlet.

Figure 25.8 shows the variation of refrigeration capacity of the condensing unit with variation in inlet water temperature to the condenser. This is obtained by superimposition of compressor characteristics of Fig.25.2 on the variation of condenser performance with inlet water temperature given in Fig.25.4. The two figures are shown side-by-side. At constant evaporator temperature of say,  $-5^\circ\text{C}$  and condenser temperature of  $30^\circ\text{C}$ , the inlet water temperature corresponding to point D is required to match the two components. Points E and F are the balance points at condenser temperatures of  $35$  and  $40^\circ\text{C}$  respectively. Line DEF is the characteristics of the condensing unit at an evaporator temperature of  $-5^\circ\text{C}$ . It is observed that the cooling capacity decreases as the inlet water temperature to condenser increases.



**Fig.25.8:** Performance of the condensing unit as a function of water temperature at condenser inlet

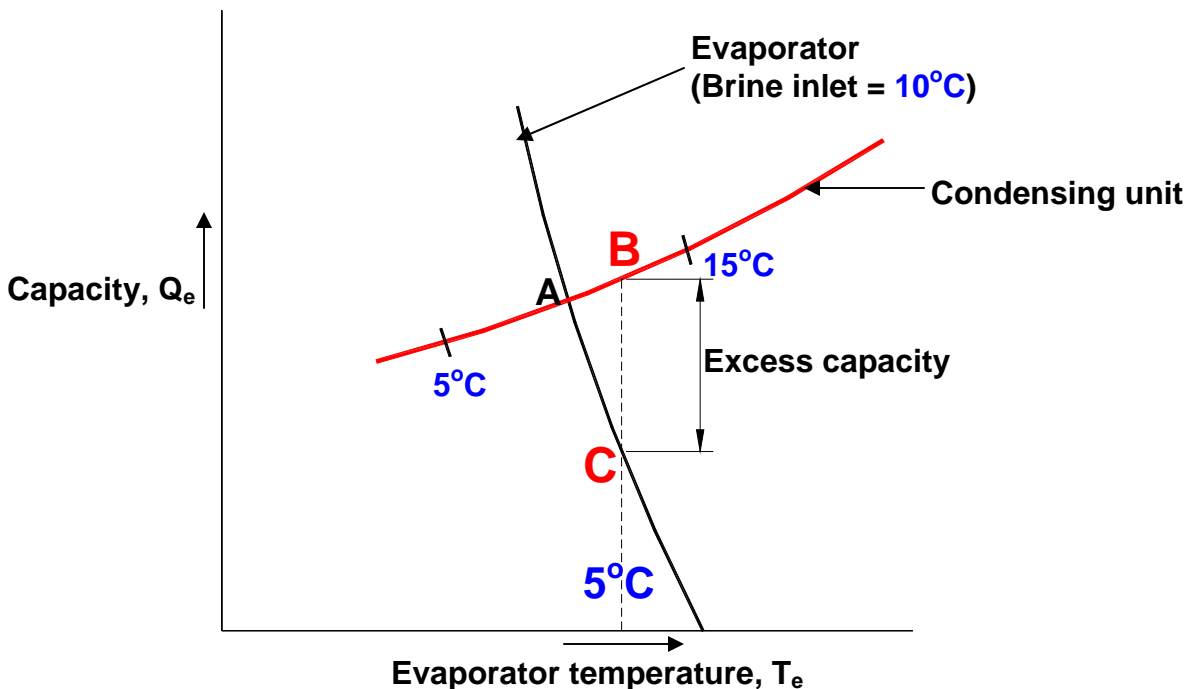
These characteristics can also be obtained by simultaneous solution of Eqns. (25.3) and (25.9) for constant water temperature at condenser inlet and constant water flow rate. For example, we wish to find the condenser temperature and capacity for a given evaporator temperature of say  $10^{\circ}\text{C}$ . An iterative procedure may be devised as follows:

- (i) For  $T_e = 10^{\circ}\text{C}$  assume a condensing temperature  $T_c = 35^{\circ}\text{C}$
- (ii) Find  $Q_e$  from Eqn.(25.3)
- (iii) Substitution of  $T_e = 10^{\circ}\text{C}$  and  $Q_e$  in Eqn.(25.9) will yield a quadratic equation for  $T_c$ . The value of  $T_c$  is found and checked against the assumed value of  $T_c$  ( $35^{\circ}\text{C}$  being the first iterate) and iteration is continued until the calculated value matches with the assumed value of condenser temperature.

### 25.7. Performance of complete system - condensing unit and evaporator:

In steady state, a balance condition must prevail between all the components, that is, between condensing unit and evaporator assuming that the expansion valve will provide appropriate mass flow rate. This confluence will represent the performance of complete single-stage vapour compression refrigeration system. The combined curves will also give insight into the off-

design performance of the system and operational problems. Superimposing Fig.25.6 for the evaporator characteristics and Fig.25.7 for condensing unit characteristics yields the balance point of the system. This is shown in Fig.25.9. The characteristic curve shown in Fig.25.9 is for constant water temperature at condenser inlet, constant flow rate to the condenser, constant compressor speed and constant brine temperature at the inlet to the evaporator. The point of intersection of the two curves gives the refrigeration capacity and the evaporator

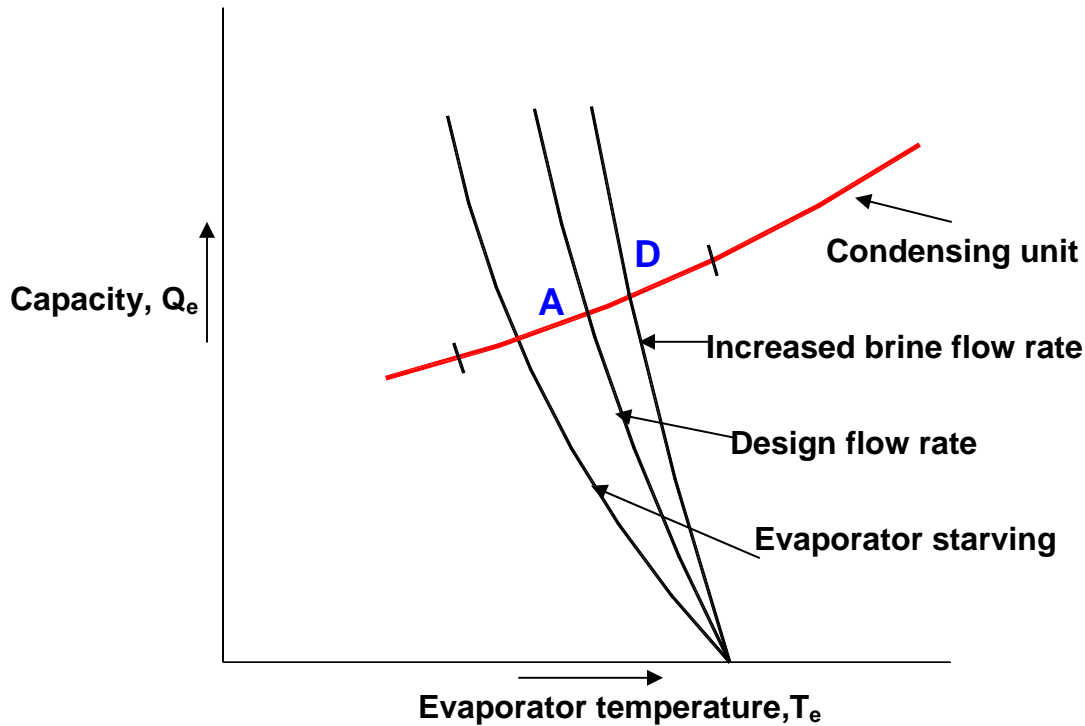


**Fig.25.9:** Performance of the complete system as an intersection of evaporator and condensing unit characteristics at a brine inlet temperature of 10°C temperature that the system will achieve.

One can study the response of the system in transient state also by this figure. In a transient state, say the evaporator temperature is 5°C. The figure shows that at this point the condensing unit has a capacity corresponding to point B while the evaporator has capacity corresponding to a lower value at C. Hence the condensing unit has excess capacity. The excess capacity will reduce the temperature of refrigerant and the metallic wall of the evaporator. This will continue until the balance point of 3°C is reached at point A.

Figure 25.10 shows the effect of brine mass flow rate compared to that at the balance point. If the brine flow rate is increased, it is observed that cooling capacity increases to point D. At higher flow rate the overall heat transfer coefficient increases while  $(T_{b,i}-T_{b,o})$  decreases permitting a larger mean temperature difference between refrigerant and brine. Therefore with increase in mass flow rate of brine, the cooling capacity increases. The pump power also

increases for the increased brine mass flow rate. Hence one has to make a compromise between increased capacity and increased cost of pump power. Figure 25.10 shows the condition for lower brine flow rate when the heat transfer coefficient on brine side decreases and temperature difference ( $T_{b,i}-T_{b,o}$ ) increases. This is referred to as starving of evaporator.



**Fig.25.10:** Influence of brine flow rate on system cooling capacity

## 25.8. Effect of expansion valve:

So far we have considered the balance between compressor, condenser and evaporator assuming that expansion valve can feed sufficient refrigerant to the evaporator so that heat transfer surface of the evaporator is wetted with refrigerant. Thermostatic expansion valve meets this requirement. Automatic expansion valve and capillary tube as observed in Chapter 24, result in a condition where sufficient quantity of refrigerant could not be supplied to evaporator. This condition was referred to as *starving of evaporator*. Starving reduces the heat transfer coefficient in evaporator since there is not sufficient refrigerant to wet the heat transfer surface consequently the cooling capacity reduces. There are other conditions also which may lead to this situation. These are as follows:

- (i) Expansion valve is too small,
- (ii) Some vapour is present in the liquid entering the expansion valve, and
- (iii) Pressure difference across the expansion valve is small

If the refrigerant charge in the system is small then condition (ii) is likely to occur. Also if the frictional pressure drop in the liquid line is large or the valve is located at higher elevation than condenser then this condition may occur. During winter months the ambient temperature is low hence in air-cooled condenser the condenser pressure is low and the difference between evaporator and condenser pressure is small, as a result the starving condition (iii) is likely to occur. In this condition the expansion valve does not feed sufficient refrigerant to the evaporator since the driving force; the pressure difference across the expansion valve is small. The evaporator pressure also decreases in response to drop in condenser pressure. The evaporator pressure may become so low that mass flow rate through compressor may decrease due to lower volumetric efficiency. Hermetic compressor depends upon the mass flow rate of refrigerant for cooling on motor and compressor. This may be adversely affected under starved condition.

## 25.9. Conclusion:

The methods presented in this chapter are useful when compressor, condenser, evaporator and expansion valve have been selected and the performance of combined system is desired. This analysis may not be useful in selecting the initial equipment. The techniques presented in this chapter are useful in predicting system performance for off-design conditions like a change in ambient temperature, condenser inlet water temperature and brine inlet temperature etc. The power requirement of the compressor has not been given due emphasis in the analysis. In fact, an equation similar to Eqn. (25.3) may be written for this also. This can also be found from known values of condenser and evaporator loads.

An important aspect of refrigeration system performance is the sensitivity analysis which deals with % change in, say cooling capacity with % change in capacity of individual components like the compressor size, heat transfer area of evaporator and condenser etc. This can easily be done by mathematical simulation using the performance characteristics of the components given by empirical equations. It has been shown in Stoecker and Jones that compressor capacity has the dominant effect on system capacity and evaporator is next in importance. An increase in compressor capacity by 10% has the effect of 6.3% increase in system capacity. A 10% increase in evaporator gives 2.1% increase in system capacity, while 10% increase in condenser gives 1.3 % increase in system capacity. Such a data along with the relative costs of the components can be used for optimization of the first cost of the system. Table 25.1 taken from Stoecker and Jones illustrates the results of sensitivity analysis.



Ratio of component capacity to base capacity				
Compressor	Condenser	Evaporator	Refrigeration capacity, TR	% increase
1.0	1.0	1.0	95.6	-
1.1	1.0	1.0	101.6	6.3
1.0	1.1	1.0	96.8	1.3
1.0	1.0	1.1	97.6	2.1
1.1	1.1	1.1	1.1	10.0

**Table 25.1:** Results of sensitivity analysis of a vapour compression refrigeration system (Stoecker and Jones, 1982)

## Questions and answers:

1. Which of the following statements are TRUE?

- a) A graphical method generally considers two components at a time for system analysis
- b) An analytical method can consider more than two components at a time for system analysis
- c) Use of analytical method requires simultaneous solution of algebraic equations
- d) All of the above

**Ans.: d)**

2. Which of the following statements are TRUE?

- a) At a fixed RPM, the cooling capacity of a reciprocating compressor decreases as the evaporator temperature decreases and condensing temperature increases
- b) At fixed water inlet temperature and flow rate, the capacity of a condenser increases as the condensing temperature and evaporator temperature increase
- c) At fixed water flow rate and condensing temperature, the capacity of a condenser increases as the water inlet temperature increases
- d) At fixed water flow rate and cooling capacity, the condensing temperature increases as the water inlet temperature increases

**Ans.: a), b) and d)**

3. Which of the following statements are TRUE?

- a) At a fixed evaporator LMTD, the cooling capacity of a brine chilling evaporator increases with brine flow rate

- b) At a constant brine flow rate and a given evaporator temperature, the cooling capacity of the evaporator increases as the brine temperature at evaporator inlet increases
- c) At a constant brine flow rate and a given evaporator temperature, the cooling capacity of the evaporator increases as the brine temperature at evaporator inlet decreases
- d) For constant cooling capacity and brine flow rate, the evaporator temperature has to decrease as the brine temperature at the inlet decreases

**Ans.: a), b) and d)**

**4. Which of the following statements are TRUE?**

- a) The performance characteristics of a condensing unit are obtained by matching the characteristics of compressor and condenser
- b) The performance characteristics of a condensing unit are obtained by matching the characteristics of evaporator and condenser
- c) The performance characteristics of a condensing unit are obtained by matching the characteristics of expansion valve and condenser
- d) The performance characteristics of a condensing unit are obtained by matching the characteristics of compressor and evaporator

**Ans.: a)**

**5. Which of the following statements are TRUE?**

- a) At constant RPM, cooling water flow rate and inlet temperature, the balance point condensing temperature increases as evaporator temperature increases
- b) At constant RPM, cooling water flow rate and inlet temperature, the balance point condensing temperature increases as evaporator temperature decreases
- c) At constant RPM, cooling water flow rate and inlet temperature, the cooling capacity at balance point increases as evaporator temperature increases
- d) At constant RPM, cooling water flow rate and inlet temperature, the cooling capacity at balance point increases as evaporator temperature decreases

**Ans.: a) and c)**

**6. Starving of evaporator followed by reduction cooling capacity occurs when:**

- a) The capacity of expansion valve is larger than required
- b) The inlet to the expansion valve is in two-phase region
- c) The expansion valve is located at a higher elevation compared to condenser
- d) There is a refrigerant leakage in the system

**Ans.: b), c) and d)**

# Lesson

# 26

# Refrigerants

## The specific objectives of this lecture are to:

1. Discuss the importance of selection of suitable refrigerant in a refrigeration system (*Section 26.1*)
2. Classify refrigerants into primary and secondary, and discuss the important differences between primary and secondary refrigerants (*Section 26.2*)
3. Discuss refrigerant selection criteria based on thermodynamic, thermophysical, environmental and economic properties (*Section 26.3*)
4. Describe the numbering system used for designating refrigerants (*Section 26.4*)
5. Present a comparison between different refrigerants (*Section 26.5*)

At the end of the lecture, the student should be able to:

1. Explain the importance of refrigerant selection
2. Differentiate between primary and secondary refrigerants
3. List the criteria used in selecting refrigerants
4. List important thermodynamic and environmental properties influencing refrigerant selection
5. Write the chemical formula of a refrigerant from its number
6. Compare different refrigerants and suggest replacements for CFCs and HCFCs

### 26.1. Introduction:

The thermodynamic efficiency of a refrigeration system depends mainly on its operating temperatures. However, important practical issues such as the system design, size, initial and operating costs, safety, reliability, and serviceability etc. depend very much on the type of refrigerant selected for a given application. Due to several environmental issues such as ozone layer depletion and global warming and their relation to the various refrigerants used, the selection of suitable refrigerant has become one of the most important issues in recent times. Replacement of an existing refrigerant by a completely new refrigerant, for whatever reason, is an expensive proposition as it may call for several changes in the design and manufacturing of refrigeration systems. Hence it is very important to understand the issues related to the selection and use of refrigerants. In principle, any fluid can be used as a refrigerant. Air used in an air cycle refrigeration system can also be considered as a refrigerant. However, in this lecture the attention is mainly focused on those fluids that can be used as refrigerants in vapour compression refrigeration systems only.

### 26.2. Primary and secondary refrigerants:

Fluids suitable for refrigeration purposes can be classified into primary and secondary refrigerants. Primary refrigerants are those fluids, which are used directly as working fluids, for example in vapour compression and vapour absorption refrigeration systems. When used in compression or absorption systems, these fluids provide refrigeration by undergoing a phase change process in the evaporator. As the name implies, secondary refrigerants are those liquids, which are used for transporting thermal energy from one location to other. Secondary refrigerants are also known under the name brines or antifreezes. Of

course, if the operating temperatures are above 0°C, then pure water can also be used as secondary refrigerant, for example in large air conditioning systems. Antifreezes or brines are used when refrigeration is required at sub-zero temperatures. Unlike primary refrigerants, the secondary refrigerants do not undergo phase change as they transport energy from one location to other. An important property of a secondary refrigerant is its freezing point. Generally, the freezing point of a brine will be lower than the freezing point of its constituents. The temperature at which freezing of a brine takes place its depends on its concentration. The concentration at which a lowest temperature can be reached without solidification is called as eutectic point. The commonly used secondary refrigerants are the solutions of water and ethylene glycol, propylene glycol or calcium chloride. These solutions are known under the general name of brines.

In this lecture attention is focused on primary refrigerants used mainly in vapour compression refrigeration systems. As discussed earlier, in an absorption refrigeration system, a refrigerant and absorbent combination is used as the working fluid.

### 26.3. Refrigerant selection criteria:

Selection of refrigerant for a particular application is based on the following requirements:

- i. Thermodynamic and thermo-physical properties
- ii. Environmental and safety properties, and
- iii. Economics

#### 26.3.1. Thermodynamic and thermo-physical properties:

The requirements are:

a) Suction pressure: At a given evaporator temperature, the saturation pressure should be above atmospheric for prevention of air or moisture ingress into the system and ease of leak detection. Higher suction pressure is better as it leads to smaller compressor displacement

b) Discharge pressure: At a given condenser temperature, the discharge pressure should be as small as possible to allow light-weight construction of compressor, condenser etc.

c) Pressure ratio: Should be as small as possible for high volumetric efficiency and low power consumption

d) Latent heat of vaporization: Should be as large as possible so that the required mass flow rate per unit cooling capacity will be small

The above requirements are somewhat contradictory, as the operating pressures, temperatures and latent heat of vaporization are related by Clausius-Clapeyron Equation:

$$\ln(P_{\text{sat}}) = -\frac{h_{\text{fg}}}{RT} + \frac{s_{\text{fg}}}{R} \quad (26.1)$$

In the above equation,  $P_{\text{sat}}$  is the saturation pressure (in atm.) at a temperature  $T$  (in Kelvin),  $h_{\text{fg}}$  and  $s_{\text{fg}}$  are enthalpy and entropy of vaporization and  $R$  is the gas constant. Since the change in entropy of vaporization is relatively small, from the above equation it can be shown that:

$$\frac{P_c}{P_e} = \exp \left[ \frac{h_{\text{fg}}}{R} \left( \frac{1}{T_e} - \frac{1}{T_c} \right) \right] \quad (26.2)$$

In the above equation,  $P_c$  and  $P_e$  are the condenser and evaporator pressures,  $T_c$  and  $T_e$  are condenser and evaporator temperatures. From the above equation, it can be seen that for given condenser and evaporator temperatures as the latent heat of vaporization increases, the pressure ratio also increases. Hence a trade-off is required between the latent heat of vaporization and pressure ratio.

In addition to the above properties; the following properties are also important:

e) Isentropic index of compression: Should be as small as possible so that the temperature rise during compression will be small

f) Liquid specific heat: Should be small so that degree of subcooling will be large leading to smaller amount of flash gas at evaporator inlet

g) Vapour specific heat: Should be large so that the degree of superheating will be small

h) Thermal conductivity: Thermal conductivity in both liquid as well as vapour phase should be high for higher heat transfer coefficients

i) Viscosity: Viscosity should be small in both liquid and vapour phases for smaller frictional pressure drops

The thermodynamic properties are interrelated and mainly depend on normal boiling point, critical temperature, molecular weight and structure.

The normal boiling point indicates the useful temperature levels as it is directly related to the operating pressures. A high critical temperature yields higher COP due to smaller compressor superheat and smaller flash gas losses. On the other hand since the vapour pressure will be low when critical temperature is high, the volumetric capacity will be lower for refrigerants with high critical temperatures. This once again shows a need for trade-off between high COP and high volumetric capacity. It is observed that for most of the refrigerants the ratio of normal boiling point to critical temperature is in the range of 0.6 to 0.7. Thus the normal boiling point is a good indicator of the critical temperature of the refrigerant.

The important properties such as latent heat of vaporization and specific heat depend on the molecular weight and structure of the molecule. Trouton's rule shows that the latent heat of vaporization will be high for refrigerants having lower molecular weight. The specific heat of refrigerant is related to the structure of the molecule. If specific heat of refrigerant vapour is low then the shape of the vapour dome will be such that the compression process starting with a saturated

point terminates in the superheated zone (i.e, **compression process will be dry**). However, a small value of vapour specific heat indicates higher degree of superheat. Since vapour and liquid specific heats are also related, a large value of vapour specific heat results in a higher value of liquid specific heat, leading to higher flash gas losses. Studies show that in general the optimum value of molar vapour specific heat lies in the range of **40 to 100 kJ/kmol.K**.

The freezing point of the refrigerant should be lower than the lowest operating temperature of the cycle to prevent blockage of refrigerant pipelines.

### **26.3.2. Environmental and safety properties:**

Next to thermodynamic and thermophysical properties, the environmental and safety properties are very important. In fact, at present the environment friendliness of the refrigerant is a major factor in deciding the usefulness of a particular refrigerant. The important environmental and safety properties are:

a) Ozone Depletion Potential (ODP): According to the Montreal protocol, the ODP of refrigerants should be zero, i.e., they should be non-ozone depleting substances. Refrigerants having non-zero ODP have either already been phased-out (e.g. R 11, R 12) or will be phased-out in near-future(e.g. R22). Since ODP depends mainly on the presence of chlorine or bromine in the molecules, refrigerants having either chlorine (i.e., CFCs and HCFCs) or bromine cannot be used under the new regulations

b) Global Warming Potential (GWP): Refrigerants should have as low a GWP value as possible to minimize the problem of global warming. Refrigerants with zero ODP but a high value of GWP (e.g. R134a) are likely to be regulated in future.

c) Total Equivalent Warming Index (TEWI): The factor TEWI considers both direct (due to release into atmosphere) and indirect (through energy consumption) contributions of refrigerants to global warming. Naturally, refrigerants with as a low a value of TEWI are preferable from global warming point of view.

d) Toxicity: Ideally, refrigerants used in a refrigeration system should be non-toxic. However, all fluids other than air can be called as toxic as they will cause suffocation when their concentration is large enough. Thus toxicity is a relative term, which becomes meaningful only when the degree of concentration and time of exposure required to produce harmful effects are specified. Some fluids are toxic even in small concentrations. Some fluids are mildly toxic, i.e., they are dangerous only when the concentration is large and duration of exposure is long. Some refrigerants such as CFCs and HCFCs are non-toxic when mixed with air in normal condition. However, when they come in contact with an open flame or an electrical heating element, they decompose forming highly toxic elements (e.g. phosgene-COCl<sub>2</sub>). In general the degree of hazard depends on:

- Amount of refrigerant used vs total space
- Type of occupancy
- Presence of open flames
- Odor of refrigerant, and
- Maintenance condition

Thus from toxicity point-of-view, the usefulness of a particular refrigerant depends on the specific application.

**e) Flammability:** The refrigerants should preferably be non-flammable and non-explosive. For flammable refrigerants special precautions should be taken to avoid accidents.

Based on the above criteria, ASHRAE has divided refrigerants into six safety groups (A1 to A3 and B1 to B3). Refrigerants belonging to Group A1 (e.g. R11, R12, R22, R134a, R744, R718) are least hazardous, while refrigerants belonging to Group B3 (e.g. R1140) are most hazardous.

Other important properties are:

**f) Chemical stability:** The refrigerants should be chemically stable as long as they are inside the refrigeration system.

**g) Compatibility** with common materials of construction (both metals and non-metals)

**h) Miscibility with lubricating oils:** Oil separators have to be used if the refrigerant is not miscible with lubricating oil (e.g. ammonia). Refrigerants that are completely miscible with oils are easier to handle (e.g. R12). However, for refrigerants with limited solubility (e.g. R 22) special precautions should be taken while designing the system to ensure oil return to the compressor

**i) Dielectric strength:** This is an important property for systems using hermetic compressors. For these systems the refrigerants should have as high a dielectric strength as possible

**j) Ease of leak detection:** In the event of leakage of refrigerant from the system, it should be easy to detect the leaks.

### 26.3.3. Economic properties:

The refrigerant used should preferably be inexpensive and easily available.

## 26.4. Designation of refrigerants:

Figure 26.1 shows the classification of fluids used as refrigerants in vapour compression refrigeration systems. Since a large number of refrigerants have been developed over the years for a wide variety of applications, a numbering system has been adopted to designate various refrigerants. From the number one can get some useful information about the type of refrigerant, its chemical composition, molecular weight etc. All the refrigerants are designated by R followed by a unique number.

**i) Fully saturated, halogenated compounds:** These refrigerants are derivatives of alkanes ( $C_nH_{2n+2}$ ) such as methane ( $CH_4$ ), ethane ( $C_2H_6$ ). These refrigerants are designated by R XYZ, where:

X+1 indicates the number of Carbon (C) atoms

Y-1 indicates number of Hydrogen (H) atoms, and



Z indicates number of Fluorine (F) atoms

The balance indicates the number of Chlorine atoms. Only 2 digits indicates that the value of X is zero.

**Ex: R 22**

$X = 0 \Rightarrow$  No. of Carbon atoms =  $0+1 = 1 \Rightarrow$  derivative of methane ( $\text{CH}_4$ )

$Y = 2 \Rightarrow$  No. of Hydrogen atoms =  $2-1 = 1$

$Z = 2 \Rightarrow$  No. of Fluorine atoms = 2

The balance =  $4 - \text{no. of (H+F) atoms} = 4-1-2 = 1 \Rightarrow$  No. of Chlorine atoms = 1

$\therefore$  The chemical formula of R 22 =  $\text{CHClF}_2$

Similarly it can be shown that the chemical formula of:

R12 =  $\text{CCl}_2\text{F}_2$

R134a =  $\text{C}_2\text{H}_2\text{F}_4$  (derivative of ethane)

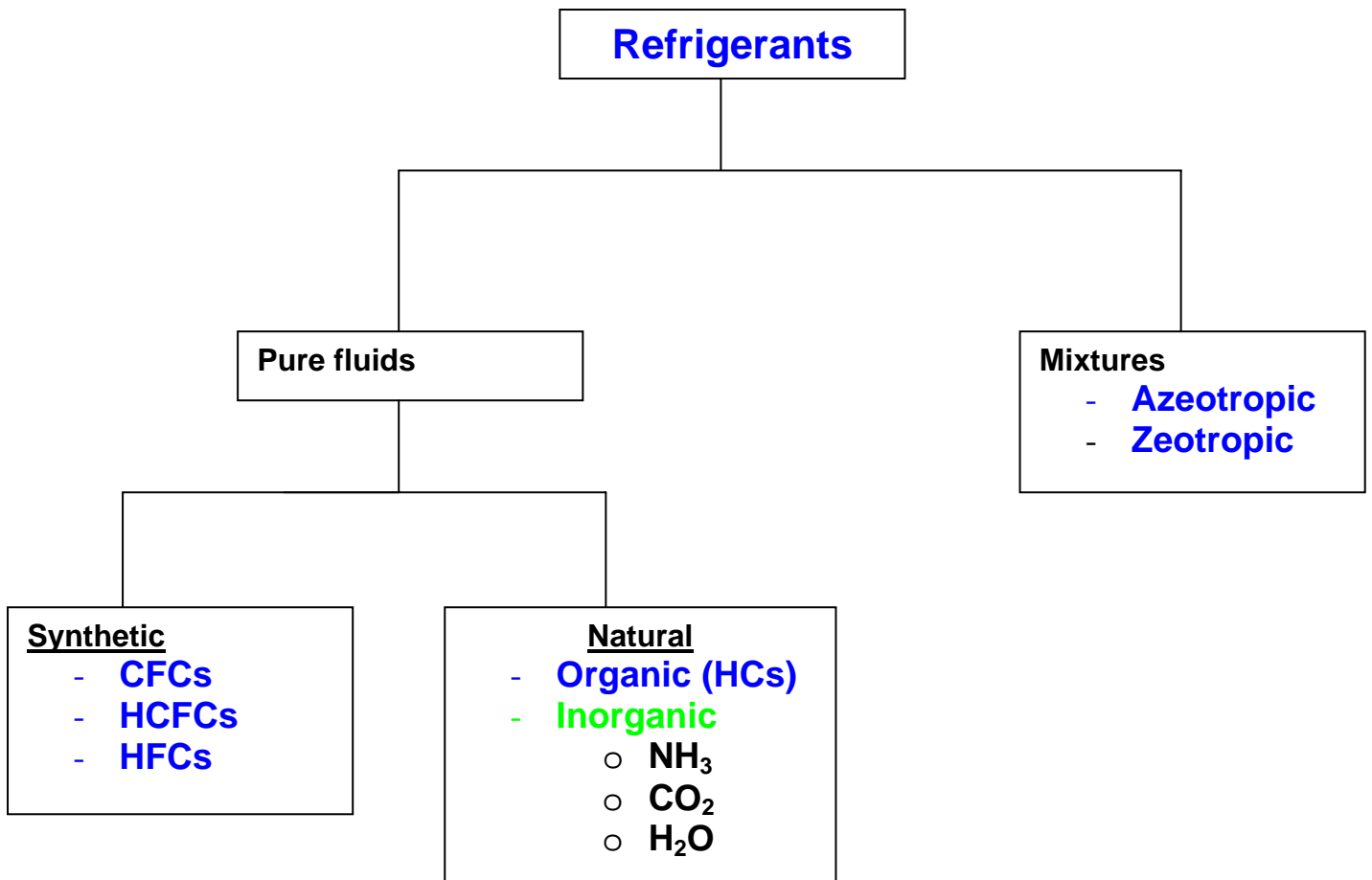
(letter a stands for isomer, e.g. molecules having same chemical composition but different atomic arrangement, e.g. R134 and R134a)

**ii) Inorganic refrigerants:** These are designated by number 7 followed by the molecular weight of the refrigerant (rounded-off).

Ex.: Ammonia: Molecular weight is 17,  $\therefore$  the designation is R 717

Carbon dioxide: Molecular weight is 44,  $\therefore$  the designation is R 744

Water: Molecular weight is 18,  $\therefore$  the designation is R 718



**Fig.26.1:** Classification of fluids used as refrigerants

iii) **Mixtures:** Azeotropic mixtures are designated by 500 series, where as zeotropic refrigerants (e.g. non-azeotropic mixtures) are designated by 400 series.

Azeotropic mixtures:

R 500: Mixture of R 12 (73.8 %) and R 152a (26.2%)

R 502: Mixture of R 22 (48.8 %) and R 115 (51.2%)

R503: Mixture of R 23 (40.1 %) and R 13 (59.9%)

R507A: Mixture of R 125 (50%) and R 143a (50%)

Zeotropic mixtures:

R404A : Mixture of R 125 (44%), R 143a (52%) and R 134a (4%)

R407A : Mixture of R 32 (20%), R 125 (40%) and R 134a (40%)

R407B : Mixture of R 32 (10%), R 125 (70%) and R 134a (20%)

R410A : Mixture of R 32 (50%) and R 125 (50%)

#### iv) Hydrocarbons:

Propane (C <sub>3</sub> H <sub>8</sub> )	:	R 290
n-butane (C <sub>4</sub> H <sub>10</sub> )	:	R 600
iso-butane (C <sub>4</sub> H <sub>10</sub> )	:	R 600a

Unsaturated Hydrocarbons:	R1150 (C <sub>2</sub> H <sub>4</sub> )
	R1270 (C <sub>3</sub> H <sub>6</sub> )

### 26.5. Comparison between different refrigerants:

Synthetic refrigerants that were commonly used for refrigeration, cold storage and air conditioning applications are: R 11 (CFC 11), R 12 (CFC 12), R 22 (HCFC 22), R 502 (CFC 12+HCFC 22) etc. However, these refrigerants have to be phased out due to their Ozone Depletion Potential (ODP). The synthetic replacements for the older refrigerants are: R-134a (HFC-134a) and blends of HFCs. Generally, synthetic refrigerants are non-toxic and non-flammable. However, compared to the natural refrigerants the synthetic refrigerants offer lower performance and they also have higher Global Warming Potential (GWP). As a result, the synthetic refrigerants face an uncertain future. The most commonly used natural refrigerant is ammonia. This is also one of the oldest known refrigerants. Ammonia has good thermodynamic, thermophysical and environmental properties. However, it is toxic and is not compatible with some of the common materials of construction such as copper, which somewhat restricts its application. Other natural refrigerants that are being suggested are hydrocarbons (HCs) and carbon di-oxide (R-744). Though these refrigerants have some specific problems owing to their eco-friendliness, they are being studied widely and are likely to play a prominent role in future.

Prior to the environmental issues of ozone layer depletion and global warming, the most widely used refrigerants were: R 11, R 12, R 22, R 502 and ammonia. Of these, R 11 was primarily used with centrifugal compressors in air conditioning applications. R 12 was used primarily in small capacity refrigeration and cold storage applications, while the other refrigerants were used in large systems such as large air conditioning plants or cold storages. Among the refrigerants used, except ammonia, all the other refrigerants are synthetic refrigerants and are non-toxic and non-flammable. Though ammonia is toxic, it has been very widely used due to its excellent thermodynamic and thermophysical properties. The scenario changed completely after the discovery of ozone layer depletion in 1974. The depletion of stratospheric ozone layer was attributed to chlorine and bromine containing chemicals such as Halons, CFCs, HCFCs etc. Since ozone layer depletion could lead to catastrophe on a global level, it has been agreed by the global community to phase out the ozone depleting substances (ODS). As a result except ammonia, all the other refrigerants used in cold storages had to be phased-out and a search for suitable replacements began in earnest. At the same time, it was also observed that in addition to ozone layer depletion, most of the conventional synthetic refrigerants also cause significant global warming. In view of the environmental problems caused by the synthetic refrigerants, opinions differed on replacements for conventional refrigerants. The alternate refrigerants can be classified into two broad groups:

- i) Non-ODS, synthetic refrigerants based on Hydro-Fluoro-Carbons (HFCs) and their blends
- ii) Natural refrigerants including ammonia, carbon dioxide, hydrocarbons and their blends

It should be noted that the use of natural refrigerants such as carbon dioxide, hydrocarbons is not a new phenomena, but is a revival of the once-used-and-discarded technologies in a much better form. Since the natural refrigerants are essentially making a comeback, one advantage of using them is that they are familiar in terms of their strengths and weaknesses. Another important advantage is that they are completely environment friendly, unlike the HFC based refrigerants, which do have considerable global warming potential. The alternate synthetic refrigerants are normally non-toxic and non-flammable. It is also possible to use blends of various HFCs to obtain new refrigerant mixtures with required properties to suit specific applications. However, most of these blends are non-azeotropic in nature, as a result there could be significant temperature glides during evaporation and condensation, and it is also important take precautions to prevent leakage, as this will change the composition of the mixture. Table 26.1 shows a list of refrigerants being replaced and their replacements.

Refrigerant	Application	Substitute suggested Retrofit(R)/New (N)
<b>R 11(CFC)</b> NBP = 23.7°C $h_{fg}$ at NBP=182.5 kJ/kg $T_{cr}$ =197.98°C $C_p/C_v$ = 1.13 ODP = 1.0 GWP = 3500	Large air conditioning systems Industrial heat pumps As foam blowing agent	R 123 (R,N)
		R 141b (N)
		R 245fa (N)
		n-pentane (R,N)
<b>R 12 (CFC)</b> NBP = -29.8°C $h_{fg}$ at NBP=165.8 kJ/kg $T_{cr}$ =112.04°C $C_p/C_v$ = 1.126 ODP = 1.0 GWP = 7300	Domestic refrigerators Small air conditioners Water coolers Small cold storages	R 22 (R,N)
		R 134a (R,N)
		R 227ea (N)
		R 401A,R 401B (R,N)
		R 411A,R 411B (R,N)
		R 717 (N)
<b>R 22 (HCFC)</b> NBP = -40.8°C $h_{fg}$ at NBP=233.2 kJ/kg $T_{cr}$ =96.02°C $C_p/C_v$ = 1.166 ODP = 0.05 GWP = 1500	Air conditioning systems Cold storages	R 410A, R 410B (N)
		R 417A (R,N)
		R 407C (R,N)
		R 507,R 507A (R,N)
		R 404A (R,N)
		R 717 (N)
<b>R 134a (HFC)</b> NBP = -26.15°C $h_{fg}$ at NBP=222.5 kJ/kg $T_{cr}$ =101.06°C $C_p/C_v$ = 1.102 ODP = 0.0 GWP = 1200	Used as replacement for R 12 in domestic refrigerators, water coolers, automobile A/Cs etc	<b>No replacement required</b> * Immiscible in mineral oils * Highly hygroscopic
<b>R 717 (NH<sub>3</sub>)</b> NBP = -33.35°C $h_{fg}$ at NBP=1368.9 kJ/kg $T_{cr}$ =133.0°C $C_p/C_v$ = 1.31 ODP = 0.0 GWP = 0.0	Cold storages Ice plants Food processing Frozen food cabinets	<b>No replacement required</b> * Toxic and flammable * Incompatible with copper * Highly efficient * Inexpensive and available
<b>R 744 (CO<sub>2</sub>)</b> NBP = -78.4°C $h_{fg}$ at 40°C=321.3 kJ/kg $T_{cr}$ =31.1°C $C_p/C_v$ = 1.3 ODP = 0.0 GWP = 1.0	Cold storages Air conditioning systems Simultaneous cooling and heating (Transcritical cycle)	<b>No replacement required</b> * Very low critical temperature * Eco-friendly * Inexpensive and available

**Table 26.1:** Refrigerants, their applications and substitutes

Refrigerant	Application	Substitute suggested Retrofit(R)/New (N)
<b>R718 (H<sub>2</sub>O)</b> NBP = 100.°C h <sub>fg</sub> at NBP=2257.9 kJ/kg T <sub>cr</sub> =374.15°C Cp/Cv = 1.33 ODP = 0.0 GWP = 1.0	Absorption systems Steam jet systems	<b>No replacement required</b> * High NBP * High freezing point * Large specific volume * Eco-friendly * Inexpensive and available
<b>R600a (iso-butane)</b> NBP = -11.73°C h <sub>fg</sub> at NBP=367.7 kJ/kg T <sub>cr</sub> =135.0°C Cp/Cv = 1.086 ODP = 0.0 GWP = 3.0	Replacement for R 12 Domestic refrigerators Water coolers	<b>No replacement required</b> * Flammable * Eco-friendly

**Table 26.1:** Refrigerants, their applications and substitutes (contd.)

### Questions and answers:

1. Which of the following statements are TRUE?

- a) A primary refrigerant does not undergo phase change in a refrigeration cycle
- b) A secondary refrigerant does not undergo phase change in a refrigeration cycle
- c) The freezing point of a brine is generally lower than the freezing point of its constituents
- d) The freezing point of a brine is generally higher than the freezing point of its constituents

**Ans.: b) and c)**

2. Which of the following statements are TRUE?

- a) The suction pressure of a refrigerant should be as high as possible
- b) The suction pressure of a refrigerant should be as low as possible
- c) The discharge pressure of a refrigerant should be as high as possible
- d) The discharge pressure of a refrigerant should be as low as possible

**Ans.: a) and d)**

3. Which of the following statements are TRUE?

- a) At a given temperature, as the latent heat of vaporization increases, the saturation pressure decreases
- b) For given evaporator and condenser temperatures, as the latent heat of vaporization increases, the pressure ratio decreases
- c) As the latent heat of vaporization increases, the required mass flow rate of refrigerant, becomes smaller for a given capacity
- d) For a given pressure ratio, as the isentropic index of compression increases, the compressor discharge temperature increases

**Ans.: a), c) and d)**

4. Which of the following statements are TRUE?

- a) A refrigerant having high critical temperature yields high COP and high volumetric capacity
- b) A refrigerant having high critical temperature yields low COP and high volumetric capacity
- c) A refrigerant having high critical temperature yields low COP and low volumetric capacity
- d) A refrigerant having high critical temperature yields high COP and low volumetric capacity

**Ans.: d)**

5. Which of the following statements are TRUE?

- a) Low molecular weight refrigerants have high latent heat of vaporization
- b) Low molecular weight refrigerants have low latent heat of vaporization
- c) For saturated state at the inlet to the compressor, a refrigerant having high vapour specific heat may give rise to wet compression
- d) For saturated state at the inlet to the compressor, a refrigerant having low vapour specific heat may give rise to wet compression

**Ans.: a) and c)**

6. The chemical formula of refrigerant R11 is:

- a)  $\text{CCl}_3\text{F}$
- b)  $\text{CClF}_3$
- c)  $\text{CClHF}$
- d)  $\text{CHF}$

**Ans.: a)**

7. The chemical formula of R141 is:

- a)  $C_2H_3ClF_3$
- b)  $C_2H_2Cl_3F$
- c)  $C_2H_3Cl_2F$
- d)  $C_2H_2ClF_3$

**Ans.: c)**

8. Which of the following statements is TRUE?

- a) Evaporation process is non-isothermal for zeotropic mixtures
- b) Evaporation process is non-isothermal for azeotropic mixtures
- c) Composition of azeotropic mixture changes in the event of a leak
- d) Composition of zeotropic mixture changes in the event of a leak

**Ans.: a) and d)**

9. Which of the following refrigerants are phased-out due to Montreal protocol on ozone layer depletion

- a) R11
- b) R21
- c) R12
- d) R32

**Ans.: a), b) and c)**

10. Which of the following refrigerants replace R12 in domestic refrigerators?

- a) R22
- b) R11
- c) R134a
- d) R141b

**Ans.: c)**

11. Which of the following refrigerants are suggested as replacements for R22 in large air conditioning and cold storage systems?

- a) R134a
- b) R21
- c) R410A
- d) R407C

**Ans.: c) and d)**



# Lesson

# 27

# Psychrometry

## The specific objectives of this lecture are to:

1. Define psychrometry and the composition of moist air (*Section 27.1*)
2. Discuss the methods used for estimating properties of moist air (*Section 27.2*)
3. Present perfect gas law model for moist air (*Section 27.2.1*)
4. Define important psychrometric properties (*Section 27.2.2*)
5. Present graphical representation of psychrometric properties on a psychrometric chart (*Section 27.2.3*)
6. Discuss measurement of psychrometric properties (*Section 27.3*)
7. Discuss straight-line law as applied to air-water mixtures (*Section 27.3.1*)
8. Discuss the concept of adiabatic saturation and thermodynamic wet bulb temperature (*Section 27.3.2*)
9. Describe a wet-bulb thermometer (*Section 27.3.3*)
10. Discuss the procedure for calculating psychrometric properties from measured values of barometric pressure, dry bulb and wet bulb temperatures (*Section 27.4*)
11. Describe a psychrometer and the precautions to be taken while using psychrometers (*Section 27.5*)

At the end of the lecture, the student should be able to:

1. Define psychrometry and atmospheric air
2. Use perfect gas law model and find the total pressure of air from partial pressures of dry air and water vapour
3. Define and estimate psychrometric properties
4. Draw the schematic of a psychrometric chart
5. Discuss the straight-line law and its usefulness in psychrometry
6. Explain the concepts of adiabatic saturation and thermodynamic wet bulb temperature
7. Differentiate between thermodynamic WBT and WBT as measured by a wet bulb thermometer
8. Estimate various psychrometric properties given any three independent properties
9. Describe a psychrometer

### 27.1. Introduction:

Atmospheric air makes up the environment in almost every type of air conditioning system. Hence a thorough understanding of the properties of atmospheric air and the ability to analyze various processes involving air is fundamental to air conditioning design.

Psychrometry is the study of the properties of mixtures of air and water vapour.

Atmospheric air is a mixture of many gases plus water vapour and a number of pollutants (Fig.27.1). The amount of water vapour and pollutants vary from place to place. The concentration of water vapour and pollutants decrease with altitude, and above an altitude of about 10 km, atmospheric air consists of only dry air. The pollutants have to be filtered out before processing the air. Hence, what we process is essentially a mixture of various gases that constitute air and water vapour. This mixture is known as moist air.

The moist air can be thought of as a mixture of dry air and moisture. For all practical purposes, the composition of dry air can be considered as constant. In 1949, a standard composition of dry air was fixed by the International Joint Committee on Psychrometric data. It is given in Table 27.1.

Constituent	Molecular weight	Mol fraction
Oxygen	32.000	0.2095
Nitrogen	28.016	0.7809
Argon	39.944	0.0093
Carbon dioxide	44.010	0.0003

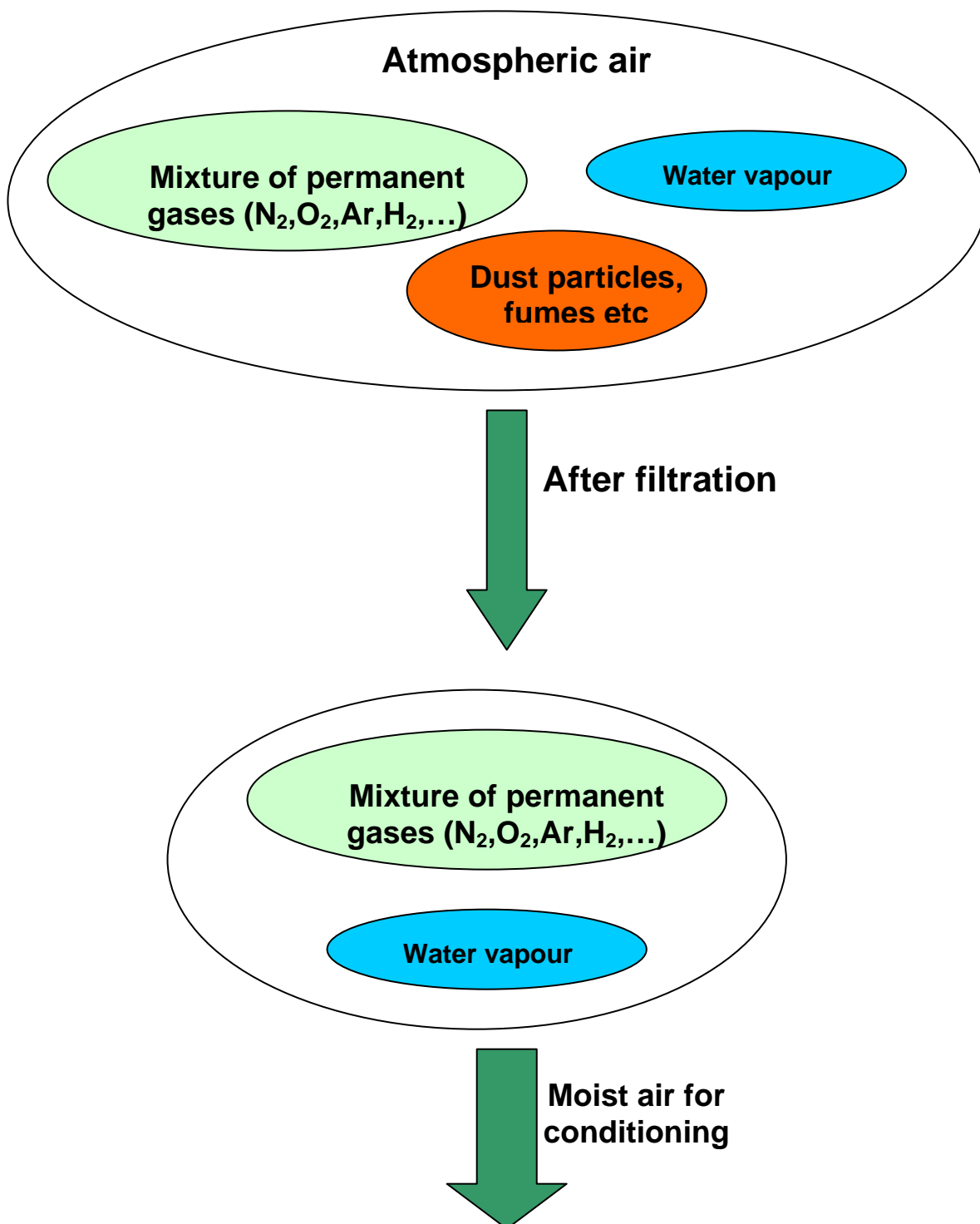
**Table 27.1:** Composition of standard air

Based on the above [composition](#) the *molecular weight of dry air is found to be 28.966 and the gas constant  $R$  is 287.035 J/kg.K.*

As mentioned before the air to be processed in air conditioning systems is a mixture of dry air and water vapour. While the composition of dry air is constant, the amount of water vapour present in the air may vary from zero to a maximum depending upon the temperature and pressure of the mixture (dry air + water vapour).

At a given temperature and pressure the dry air can only hold a certain maximum amount of moisture. When the moisture content is maximum, then the air is known as saturated air, which is established by a neutral equilibrium between the moist air and the liquid or solid phases of water.

For calculation purposes, the molecular weight of water vapour is taken as 18.015 and its gas constant is 461.52 J/kg.K.



**Fig.27.1:** Atmospheric air

## 27.2. Methods for estimating properties of moist air:

In order to perform air conditioning calculations, it is essential first to estimate various properties of air. It is difficult to estimate the exact property values of moist air as it is a mixture of several permanent gases and water vapour. However, moist air upto 3 atm. pressure is found to obey perfect gas law with accuracy sufficient for engineering calculations. For higher accuracy Goff and Gratch tables can be used for estimating moist air properties. These tables are obtained using mixture models based on fundamental principles of statistical mechanics that take into account the real gas behaviour of dry air and water vapour. However, these tables are valid for a barometric pressure of 1 atm. only. Even though the calculation procedure is quite complex, using the mixture models it is possible to estimate moist air properties at

other pressures also. However, since in most cases the pressures involved are low, one can apply the perfect gas model to estimate psychrometric properties.

### 27.2.1. Basic gas laws for moist air:

According to the Gibbs-Dalton law for a mixture of perfect gases, the total pressure exerted by the mixture is equal to the sum of partial pressures of the constituent gases. According to this law, for a homogeneous perfect gas mixture occupying a volume  $V$  and at temperature  $T$ , each constituent gas behaves as though the other gases are not present (i.e., there is no interaction between the gases). Each gas obeys perfect gas equation. Hence, the partial pressures exerted by each gas,  $p_1, p_2, p_3 \dots$  and the total pressure  $p_t$  are given by:

$$p_1 = \frac{n_1 R_u T}{V}; p_2 = \frac{n_2 R_u T}{V}; p_3 = \frac{n_3 R_u T}{V} \dots \dots \quad (27.1)$$

$$p_t = p_1 + p_2 + p_3 + \dots \dots$$

where  $n_1, n_2, n_3, \dots$  are the number of moles of gases 1, 2, 3, ...

Applying this equation to moist air.

$$p = p_t = p_a + p_v \quad (27.2)$$

where  $p = p_t =$  total barometric pressure  
 $p_a =$  partial pressure of dry air  
 $p_v =$  partial pressure of water vapour

### 27.2.2. Important psychrometric properties:

Dry bulb temperature (DBT) is the temperature of the moist air as measured by a standard thermometer or other temperature measuring instruments.

Saturated vapour pressure ( $p_{sat}$ ) is the saturated partial pressure of water vapour at the dry bulb temperature. This is readily available in thermodynamic tables and charts. ASHRAE suggests the following regression equation for saturated vapour pressure of water, which is valid for 0 to 100°C.

$$\ln(p_{sat}) = \frac{c_1}{T} + c_2 + c_3 T + c_4 T^2 + c_5 T^3 + c_6 \ln(T) \quad (27.3)$$

where  $p_{sat}$  = saturated vapor pressure of water in kiloPascals  
 $T$  = temperature in K

The regression coefficients  $c_1$  to  $c_6$  are given by:

$$c_1 = -5.80022006E+03, c_2 = -5.516256E+00, c_3 = -4.8640239E-02$$

$$c_4 = 4.1764768E-05, c_5 = -1.4452093E-08, c_6 = 6.5459673E+00$$

Relative humidity ( $\phi$ ) is defined as the ratio of the mole fraction of water vapour in moist air to mole fraction of water vapour in saturated air at the same temperature and pressure. Using perfect gas equation we can show that:

$$\phi = \frac{\text{partial pressure of water vapour}}{\text{saturation pressure of pure water vapour at same temperature}} = \frac{p_v}{p_{\text{sat}}} \quad (27.4)$$

Relative humidity is normally expressed as a percentage. When  $\Phi$  is 100 percent, the air is saturated.

Humidity ratio (W): The humidity ratio (or specific humidity)  $W$  is the mass of water associated with each kilogram of dry air<sup>1</sup>. Assuming both water vapour and dry air to be perfect gases<sup>2</sup>, the humidity ratio is given by:

$$W = \frac{\text{kg of water vapour}}{\text{kg of dry air}} = \frac{p_v V / R_v T}{p_a V / R_a T} = \frac{p_v / R_v}{(p_t - p_v) / R_a} \quad (27.5)$$

Substituting the values of gas constants of water vapour and air  $R_v$  and  $R_a$  in the above equation; the humidity ratio is given by:

$$W = 0.622 \frac{p_v}{p_t - p_v} \quad (27.6)$$

For a given barometric pressure  $p_t$ , given the DBT, we can find the saturated vapour pressure  $p_{\text{sat}}$  from the thermodynamic property tables on steam. Then using the above equation, we can find the humidity ratio at saturated conditions,  $W_{\text{sat}}$ .

It is to be noted that,  $W$  is a function of both total barometric pressure and vapor pressure of water.

Dew-point temperature: If unsaturated moist air is cooled at constant pressure, then the temperature at which the moisture in the air begins to condense is known as dew-point temperature (DPT) of air. An approximate equation for dew-point temperature is given by:

$$\text{DPT} = \frac{4030(\text{DBT} + 235)}{4030 - (\text{DBT} + 235)\ln\phi} - 235 \quad (27.7)$$

where  $\phi$  is the relative humidity (in fraction). DBT & DPT are in °C. Of course, since from its definition, the dew point temperature is the saturation temperature corresponding to the vapour pressure of water vapour, it can be obtained from steam tables or using Eqn.(27.3).

<sup>1</sup> Properties such as humidity ratio, enthalpy and specific volume are based on 1 kg of dry air. This is useful as the total mass of moist air in a process varies by the addition/removal of water vapour, but the mass of dry air remains constant.

<sup>2</sup> Dry air is assumed to be a perfect gas as its temperature is high relative to its saturation temperature, and water vapour is assumed to be a perfect gas because its pressure is low relative to its saturation pressure. These assumptions result in accuracies, that are, sufficient for engineering calculations (less than 0.7 percent as shown by Threlkeld). However, more accurate results can be obtained by using the data developed by Goff and Gratch in 1945.

Degree of saturation  $\mu$ : The degree of saturation is the ratio of the humidity ratio  $W$  to the humidity ratio of a saturated mixture  $W_s$  at the same temperature and pressure, i.e.,

$$\mu = \left. \frac{W}{W_s} \right|_{t,P} \quad (27.8)$$

Enthalpy: The enthalpy of moist air is the sum of the enthalpy of the dry air and the enthalpy of the water vapour. Enthalpy values are always based on some reference value. For moist air, the enthalpy of dry air is given a zero value at  $0^\circ\text{C}$ , and for water vapour the enthalpy of saturated water is taken as zero at  $0^\circ\text{C}$ .

The enthalpy of moist air is given by:

$$h = h_a + Wh_g = c_p t + W(h_{fg} + c_{pw} t) \quad (27.9)$$

where  $c_p$  = specific heat of dry air at constant pressure, kJ/kg.K  
 $c_{pw}$  = specific heat of water vapor, kJ/kg.K  
 $t$  = Dry-bulb temperature of air-vapor mixture,  $^\circ\text{C}$   
 $W$  = Humidity ratio, kg of water vapor/kg of dry air  
 $h_a$  = enthalpy of dry air at temperature  $t$ , kJ/kg  
 $h_g$  = enthalpy of water vapor<sup>3</sup> at temperature  $t$ , kJ/kg  
 $h_{fg}$  = latent heat of vaporization at  $0^\circ\text{C}$ , kJ/kg

The unit of  $h$  is kJ/kg of dry air. Substituting the approximate values of  $c_p$  and  $h_g$ , we obtain:

$$h = 1.005 t + W(2501 + 1.88t) \quad (27.10)$$

Humid specific heat: From the equation for enthalpy of moist air, the humid specific heat of moist air can be written as:

$$c_{pm} = c_p + W.c_{pw} \quad (27.11)$$

where  $c_{pm}$  = humid specific heat, kJ/kg.K  
 $c_p$  = specific heat of dry air, kJ/kg.K  
 $c_{pw}$  = specific heat of water vapor, kJ/kg  
 $W$  = humidity ratio, kg of water vapor/kg of dry air

Since the second term in the above equation ( $w.c_{pw}$ ) is very small compared to the first term, for all practical purposes, the humid specific heat of moist air,  $c_{pm}$  can be taken as 1.0216 kJ/kg dry air.K

Specific volume: The specific volume is defined as the number of cubic meters of moist air per kilogram of dry air. From perfect gas equation since the volumes occupied by the individual substances are the same, the specific volume is also equal to the number of cubic meters of dry air per kilogram of dry air, i.e.,

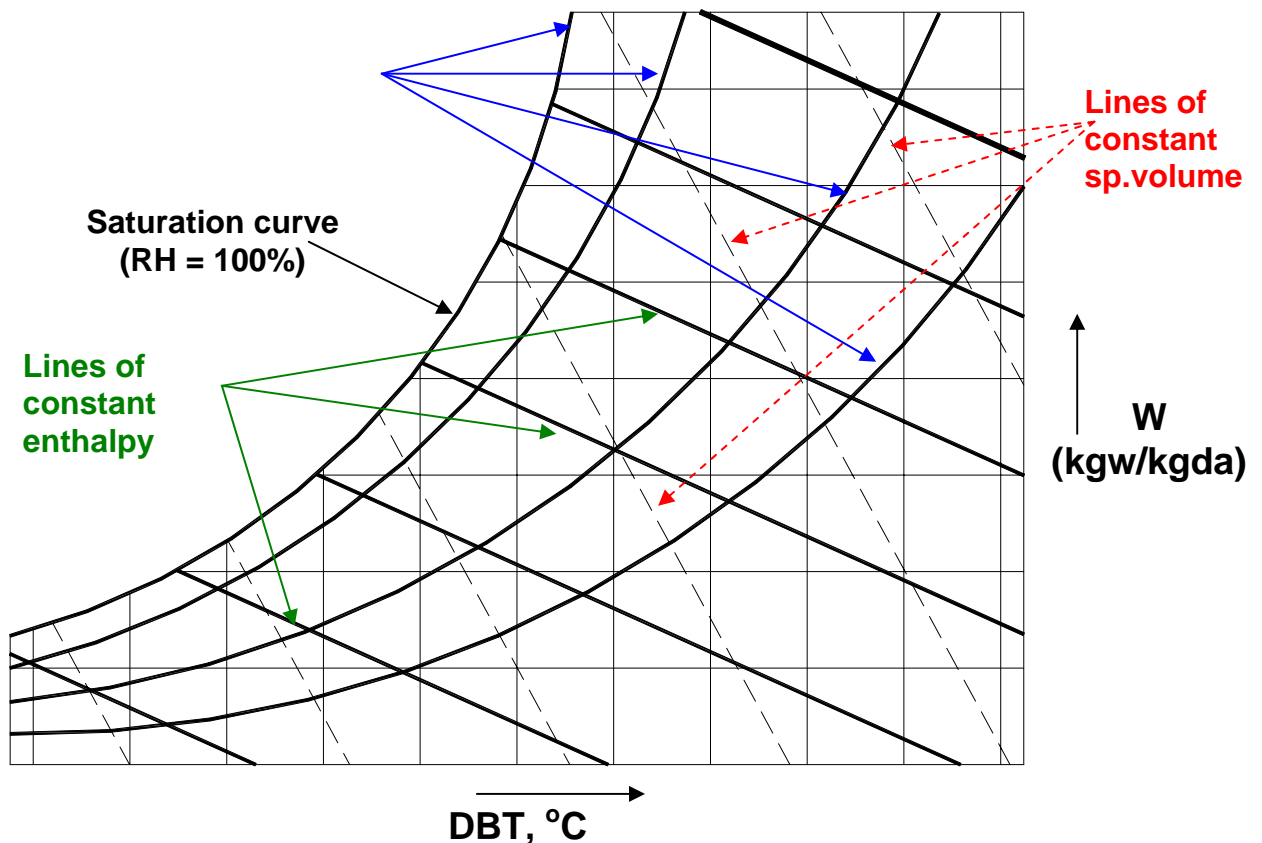
---

<sup>3</sup> Though the water vapor in moist air is likely to be superheated, no appreciable error results if we assume it to be saturated. This is because of the fact that the constant temperature lines in the superheated region on a Mollier chart ( $h$  vs  $s$ ) are almost horizontal.

$$v = \frac{R_a T}{p_a} = \frac{R_a T}{p_t - p_v} \quad \text{m}^3 / \text{kg dry air} \quad (27.12)$$

### 27.2.3. Psychrometric chart

A *Psychrometric chart* graphically represents the thermodynamic properties of moist air. Standard psychrometric charts are bounded by the dry-bulb temperature line (abscissa) and the vapour pressure or humidity ratio (ordinate). The Left Hand Side of the psychrometric chart is bounded by the saturation line. Figure 27.2 shows the schematic of a psychrometric chart. Psychrometric charts are readily available for standard barometric pressure of 101.325 kPa at sea level and for normal temperatures (0-50°C). ASHRAE has also developed psychrometric charts for other temperatures and barometric pressures (for low temperatures: -40 to 10°C, high temperatures 10 to 120°C and very high temperatures 100 to 120°C)



**Fig.27.2:** Schematic of a psychrometric chart for a given barometric pressure

### 27.3. Measurement of psychrometric properties:

Based on Gibbs' phase rule, the thermodynamic state of moist air is uniquely fixed if the barometric pressure and two other independent properties are known. This means that at a given barometric pressure, the state of moist air can be determined by measuring any two independent properties. One of them could be the dry-bulb temperature (DBT), as the measurement of this temperature is fairly simple and accurate. The accurate measurement of other independent parameters such as humidity ratio is very difficult in practice. Since measurement of temperatures is



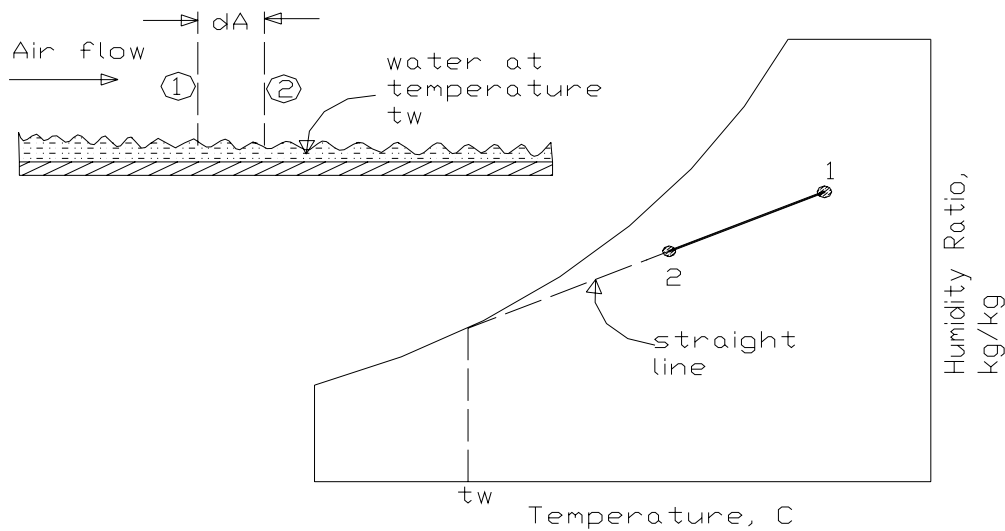
easier, it would be convenient if the other independent parameter is also a temperature. Of course, this could be the dew-point temperature (DPT), but it is observed that accurate measurement of dew-point temperature is difficult. In this context, a new independent temperature parameter called the *wet-bulb temperature* (WBT) is defined. Compared to DPT, it is easier to measure the wet-bulb temperature of moist air. Thus knowing the dry-bulb and wet-bulb temperatures from measurements, it is possible to find the other properties of moist air.

To understand the concept of wet-bulb temperature, it is essential to understand the process of combined heat and mass transfer.

### 27.3.1. Combined heat and mass transfer; the straight line law

The straight line law states that “when air is transferring heat and mass (water) to or from a wetted surface, the condition of air shown on a psychrometric chart drives towards the saturation line at the temperature of the wetted surface”.

For example, as shown in Fig.27.3, when warm air passes over a wetted surface its temperature drops from 1 to 2. Also, since the vapor pressure of air at 1 is greater than the saturated vapor pressure at  $t_w$ , there will be moisture transfer from air to water, i.e., the warm air in contact with cold wetted surface cools and dehumidifies. According to the straight line law, the final condition of air (i.e., 2) lies on a straight line joining 1 with  $t_w$  on the saturation line. This is due to the value of unity of the Lewis number, that was discussed in an earlier chapter on analogy between heat and mass transfer.



**Fig.27.3:** Principle of straight-line law for air-water mixtures

### 27.3.2. Adiabatic saturation and thermodynamic wet bulb temperature:

Adiabatic saturation temperature is defined as that temperature at which water, by evaporating into air, can bring the air to saturation at the same temperature adiabatically. An adiabatic saturator is a device using which one can measure theoretically the adiabatic saturation temperature of air.

As shown in Fig.27.4, an adiabatic saturator is a device in which air flows through an infinitely long duct containing water. As the air comes in contact with

water in the duct, there will be heat and mass transfer between water and air. If the duct is infinitely long, then at the exit, there would exist perfect equilibrium between air and water at steady state. Air at the exit would be fully saturated and its temperature is equal to that of water temperature. The device is adiabatic as the walls of the chamber are thermally insulated. In order to continue the process, make-up water has to be provided to compensate for the amount of water evaporated into the air. The temperature of the make-up water is controlled so that it is the same as that in the duct.

After the adiabatic saturator has achieved a steady-state condition, the temperature indicated by the thermometer immersed in the water is the thermodynamic wet-bulb temperature. The thermodynamic wet bulb temperature will be less than the entering air DBT but greater than the dew point temperature.

Certain combinations of air conditions will result in a given sump temperature, and this can be defined by writing the energy balance equation for the adiabatic saturator. Based on a unit mass flow rate of dry air, this is given by:

$$h_1 = h_2 - (W_2 - W_1)h_f \quad (27.13)$$

where  $h_f$  is the enthalpy of saturated liquid at the sump or thermodynamic wet-bulb temperature,  $h_1$  and  $h_2$  are the enthalpies of air at the inlet and exit of the adiabatic saturator, and  $W_1$  and  $W_2$  are the humidity ratio of air at the inlet and exit of the adiabatic saturator, respectively.

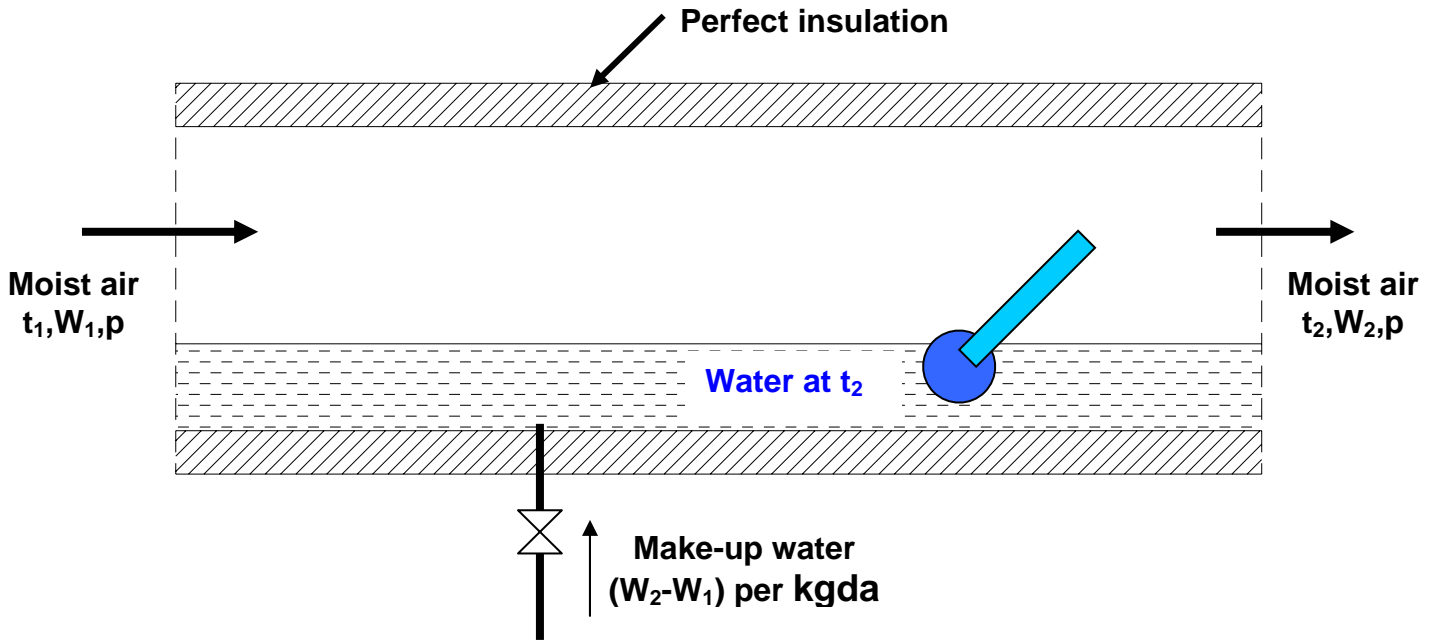
It is to be observed that the thermodynamic wet-bulb temperature is a thermodynamic property, and is independent of the path taken by air. Assuming the humid specific heat to be constant, from the enthalpy balance, the thermodynamic wet-bulb temperature can be written as:

$$t_2 = t_1 - \frac{h_{fg,2}}{c_{pm}} (w_2 - w_1) \quad (27.14)$$

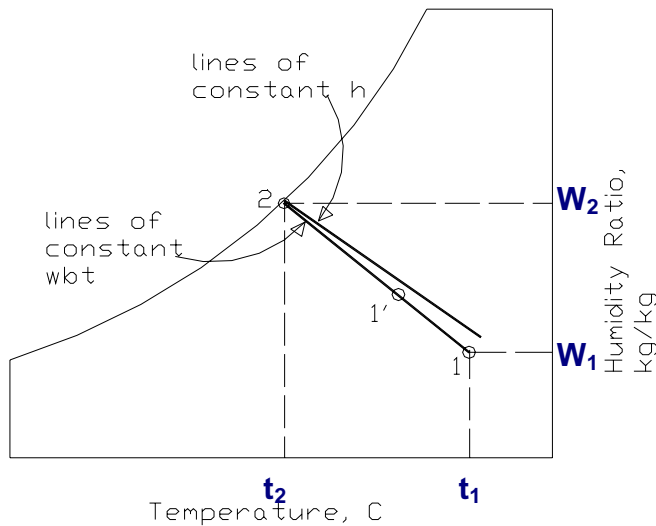
where  $h_{fg,2}$  is the latent heat of vaporization at the saturated condition 2. Thus measuring the dry bulb ( $t_1$ ) and wet bulb temperature ( $t_2$ ) one can find the inlet humidity ratio ( $W_1$ ) from the above expression as the outlet saturated humidity ratio ( $W_2$ ) and latent heat heat of vaporizations are functions of  $t_2$  alone (at fixed barometric pressure).

On the psychrometric chart as shown in Fig.27.4, point 1 lies below the line of constant enthalpy that passes through the saturation point 2.  $t_2 = f(t_1, W_1)$  is not a unique function, in the sense that there can be several combinations of  $t_1$  and  $W_1$  which can result in the same sump temperature in the adiabatic saturator. A line passing through all these points is a constant wet bulb temperature line. Thus all inlet conditions that result in the same sump temperature, for example point 1' have the same wet bulb temperature. The line is a straight line according to the straight-line law. The straight-line joining 1 and 2 represents the path of the air as it passes through the adiabatic saturator.

Normally lines of constant wet bulb temperature are shown on the psychrometric chart. The difference between actual enthalpy and the enthalpy obtained by following constant wet-bulb temperature is equal to  $(w_2 - w_1)h_f$ .



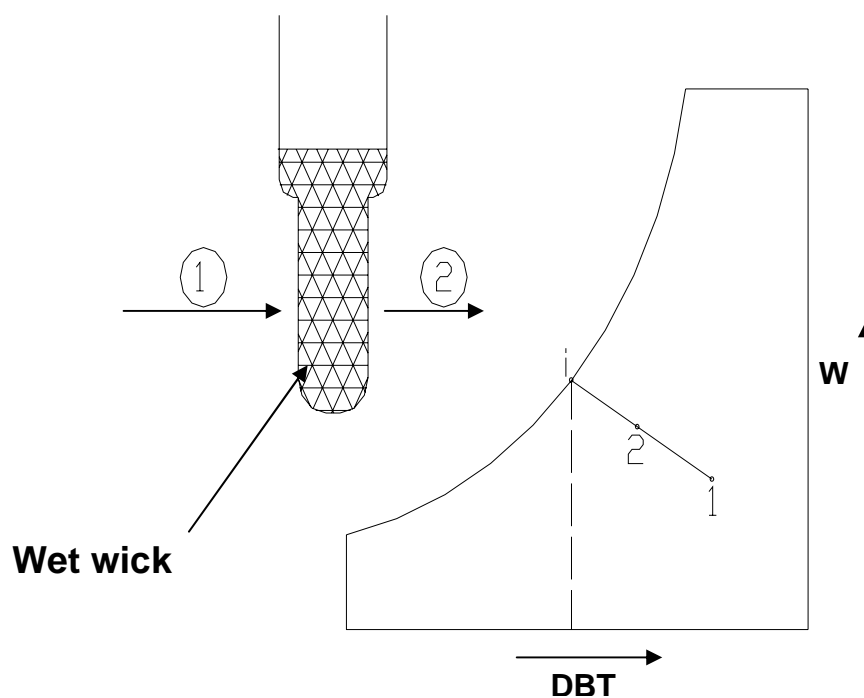
**Fig.27.4:** The process of adiabatic saturation of air



**Fig.27.5:** Adiabatic saturation process 1-2 on psychrometric chart

### 27.3.3. Wet-Bulb Thermometer:

In practice, it is not convenient to measure the wet-bulb temperature using an adiabatic saturator. In stead, a thermometer with a wetted wick is used to measure the wet bulb temperature as shown in Fig.27.6. It can be observed that since the area of the wet bulb is finite, the state of air at the exit of the wet bulb will not be saturated, in stead it will be point 2 on the straight line joining 1 and i, provided the temperature of water on the wet bulb is i. It has been shown by Carrier, that this is a valid assumption for air-water mixtures. Hence for air-water mixtures, one can assume that the temperature measured by the wet-bulb thermometer is equal to the thermodynamic wet-bulb temperature<sup>4</sup>. For other gas-vapor mixtures, there can be appreciable difference between the thermodynamic and actual wet-bulb temperatures.



**Fig.27.6:** Schematic of a wet-bulb thermometer and the process on psychrometric chart

<sup>4</sup> By performing energy balance across the wet-bulb, it can be shown that, the temperature measured by the wet-bulb thermometer is:

$$t_2 = t_1 - (k_w / h_c) h_{fg} (w_i - w); \text{ where } k_w \text{ is the mass transfer coefficient}$$

for air-water mixtures, the ratio  $(h_c / k_w c_{pm}) = \text{Lewis number}$  is  $\approx 1$ , hence, the wick temperature is approximately equal to the thermodynamic wet-bulb temperature.

It should be noted that, unlike thermodynamic WBT, the WBT of wet bulb thermometer is not a thermodynamic property as it depends upon the rates of heat and mass transfer between the wick and air.

## 27.4. Calculation of psychrometric properties from p, DBT and WBT:

As mentioned before, to fix the thermodynamic state of moist air, we need to know three independent properties. The properties that are relatively easier to measure, are: the barometric pressure, dry-bulb temperature and wet-bulb temperature. For a given barometric pressure, knowing the dry bulb and wet bulb temperatures, all other properties can be easily calculated from the psychrometric equations. The following are the empirical relations for the vapor pressure of water in moist air:

i) Modified Apjohn equation:

$$p_v = p'_v - \frac{1.8p(t - t')}{2700} \quad (27.15)$$

ii) Modified Ferrel equation:

$$p_v = p'_v - 0.00066p(t - t') \left[ 1 + \frac{1.8t}{1571} \right] \quad (27.16)$$

iii) Carrier equation:

$$p_v = p'_v - \frac{1.8(p - p'_v)(t - t')}{2800 - 1.3(1.8t + 32)} \quad (27.17)$$

where t = dry bulb temperature, °C  
t' = wet bulb temperature, °C  
p = barometric pressure  
p<sub>v</sub> = vapor pressure  
p'<sub>v</sub> = saturation vapor pressure at wet-bulb temperature

The units of all the pressures in the above equations should be consistent.

Once the vapor pressure is calculated, then all other properties such as relative humidity, humidity ratio, enthalpy, humid volume etc. can be calculated from the psychrometric equations presented earlier.

## 27.5. Psychrometer:

Any instrument capable of measuring the psychrometric state of air is called a psychrometer. As mentioned before, in order to measure the psychrometric state of air, it is required to measure three independent parameters. Generally two of these are the barometric pressure and air dry-bulb temperature as they can be measured easily and with good accuracy.

Two types of psychrometers are commonly used. Each comprises of two thermometers with the bulb of one covered by a moist wick. The two sensing bulbs are separated and shaded from each other so that the radiation heat transfer between them becomes negligible. Radiation shields may have to be used over the bulbs if the surrounding temperatures are considerably different from the air temperature.

The *sling psychrometer* is widely used for measurements involving room air or other applications where the air velocity inside the room is small. The sling psychrometer consists of two thermometers mounted side by side and fitted in a frame with a handle for whirling the device through air. The required air circulation ( $\approx 3$  to  $5$  m/s) over the sensing bulbs is obtained by whirling the psychrometer ( $\approx 300$  RPM). Readings are taken when both the thermometers show steady-state readings.

In the *aspirated psychrometer*, the thermometers remain stationary, and a small fan, blower or syringe moves the air across the thermometer bulbs.

The function of the wick on the wet-bulb thermometer is to provide a thin film of water on the sensing bulb. To prevent errors, there should be a continuous film of water on the wick. The wicks made of cotton or cloth should be replaced frequently, and only distilled water should be used for wetting it. The wick should extend beyond the bulb by 1 or 2 cms to minimize the heat conduction effects along the stem.

Other types of psychrometric instruments:

1. Dunmore Electric Hygrometer
2. DPT meter
3. Hygrometer (Using horse's or human hair)

## Questions and answers:

1. Which of the following statements are TRUE?

- a) The maximum amount of moisture air can hold depends upon its temperature and barometric pressure
- b) Perfect gas model can be applied to air-water mixtures when the total pressure is high
- c) The minimum number of independent properties to be specified for fixing the state of moist air is two
- d) The minimum number of independent properties to be specified for fixing the state of moist air is three

**Ans.: a) and d)**

2. Which of the following statements are TRUE?

- a) Straight-line law is applicable to any fluid-air mixtures
- b) Straight-line law is applicable to any water-air mixtures only
- c) Straight-line holds good as long as the Prandtl number is close to unity
- d) Straight-line holds good as long as the Lewis number is close to unity

**Ans.: b) and d)**

3. Which of the following statements are TRUE?

- a) When the dry bulb temperature is equal to dew point temperature, the relative humidity of air-water mixture is 1.0

- b) All specific psychrometric properties of moist air are based on unit mass of water vapour
- c) All specific psychrometric properties of moist air are based on unit mass of dry air
- d) All specific psychrometric properties of moist air are based on unit mass of moist air

**Ans.: a) and d)**

4. Which of the following statements are TRUE?

- a) Thermodynamic WBT is a property of moist air, while WBT as measured by wet bulb thermometer is not a property
- b) Both the thermodynamic WBT and WBT as measured by wet bulb thermometer are properties of moist air
- c) Under no circumstances, dry bulb and wet bulb temperatures are equal
- d) Wet bulb temperature is always lower than dry bulb temperature, but higher than dew point temperature

**Ans.: a)**

5. On a particular day the weather forecast states that the dry bulb temperature is 37°C, while the relative humidity is 50% and the barometric pressure is 101.325 kPa. Find the humidity ratio, dew point temperature and enthalpy of moist air on this day.

**Ans.:**

At 37°C the saturation pressure ( $p_s$ ) of water vapour is obtained from steam tables as **6.2795 kPa.**

Since the relative humidity is 50%, the vapour pressure of water in air ( $p_v$ ) is:

$$p_v = 0.5 \times p_s = 0.5 \times 6.2795 = 3.13975 \text{ kPa}$$

the humidity ratio  $W$  is given by:

$$W = 0.622 \times p_v / (p_t - p_v) = 0.622 \times 3.13975 / (101.325 - 3.13975) = 0.01989 \text{ kgw/kgda}$$

**(Ans.)**

The enthalpy of air ( $h$ ) is given by the equation:

$$h = 1.005t + W(2501 + 1.88t) = 1.005 \times 37 + 0.01989(2501 + 1.88 \times 37) = 88.31 \text{ kJ/kgda}$$

**(Ans.)**

6. Will the moisture in the above air condense when it comes in contact with a cold surface whose surface temperature is 24°C?

**Ans.:** Moisture in condense when it is cooled below its dew point temperature.

The dew point temperature of the air at 37°C and 50 % relative humidity is equal to the saturation temperature of water at a vapour pressure of 3.13975 kPa.

From steam tables, the saturation temperature of water at 3.13975 Kpa is 24.8°C, hence moisture in air will condense when it comes in contact with the cold surface whose temperature is lower than the dew point temperature. **(Ans.)**

7. Moist air at 1 atm. pressure has a dry bulb temperature of 32°C and a wet bulb temperature of 26°C. Calculate a) the partial pressure of water vapour, b) humidity ratio, c) relative humidity, d) dew point temperature, e) density of dry air in the mixture, f) density of water vapour in the mixture and g) enthalpy of moist air using perfect gas law model and psychrometric equations.

**Ans.:**

a) Using modified Apjohn equation and the values of DBT, WBT and barometric pressure, the vapour pressure is found to be:

$$p_v = 2.956 \text{ kPa} \quad \text{(Ans.)}$$

b) The humidity ratio W is given by:

$$W = 0.622 \times 2.956 / (101.325 - 2.956) = 0.0187 \text{ kgw/kgda} \quad \text{(Ans.)}$$

c) Relative humidity RH is given by:

$$RH = (p_v/p_s) \times 100 = (p_v/\text{saturation pressure at } 32^\circ\text{C}) \times 100$$

From steam tables, the saturation pressure of water at 32°C is 4.7552 kPa, hence,

$$RH = (2.956/4.7552) \times 100 = 62.16\% \quad \text{(Ans.)}$$

d) Dew point temperature is the saturation temperature of steam at 2.956 kPa. Hence using steam tables we find that:

$$DPT = T_{\text{sat}}(2.956 \text{ kPa}) = 23.8^\circ\text{C} \quad \text{(Ans.)}$$

e) Density of dry air and water vapour

Applying perfect gas law to dry air:

$$\begin{aligned} \text{Density of dry air } \rho_a &= (p_a/R_a T) = (p_t - p_v) / R_a T = (101.325 - 2.956) / (287.035 \times 305) \times 10^3 \\ &= 1.1236 \text{ kg/m}^3 \text{ of dry air} \quad \text{(Ans.)} \end{aligned}$$

f) Similarly the density of water vapour in air is obtained using perfect gas law as:

$$\begin{aligned} \text{Density of water vapour } \rho_v &= (p_v/R_v T) = 2.956 \times 10^3 / (461.52 \times 305) = 0.021 \text{ kg/m}^3 \\ &\quad \text{(Ans.)} \end{aligned}$$

g) Enthalpy of moist air is found from the equation:

$$\begin{aligned} h &= 1.005 \times t + W(2501 + 1.88 \times t) = 1.005 \times 32 + 0.0187(2501 + 1.88 \times 32) \\ h &= 80.05 \text{ kJ/kg of dry air} \quad \text{(Ans.)} \end{aligned}$$



Lesson

28

Psychrometric Processes

## The specific objectives of this lecture are to:

1. Introduction to psychrometric processes and their representation (*Section 28.1*)
2. Important psychrometric processes namely, sensible cooling and heating, cooling and dehumidification, cooling and humidification, heating and humidification, chemical dehumidification and mixing of air streams (*Section 28.2*)
3. Representation of the above processes on psychrometric chart and equations for heat and mass transfer rates (*Section 28.2*)
4. Concept of Sensible Heat Factor, By-pass Factor and apparatus dew point temperature of cooling coils (*Section 28.2*)
5. Principle of air washers and various psychrometric processes that can be performed using air washers (*Section 28.3*)
6. Concept of enthalpy potential and its use (*Section 28.4*)

At the end of the lecture, the student should be able to:

1. Represent various psychrometric processes on psychrometric chart
2. Perform calculations for various psychrometric processes using the psychrometric charts and equations
3. Define sensible heat factor, by-pass factor, contact factor and apparatus dew point temperature
4. Describe the principle of an air washer and its practical use
5. Derive equation for total heat transfer rate in terms of enthalpy potential and explain the use of enthalpy potential

## 28.1. Introduction:

In the design and analysis of air conditioning plants, the fundamental requirement is to identify the various processes being performed on air. Once identified, the processes can be analyzed by applying the laws of conservation of mass and energy. All these processes can be plotted easily on a psychrometric chart. This is very useful for quick visualization and also for identifying the changes taking place in important properties such as temperature, humidity ratio, enthalpy etc. The important processes that air undergoes in a typical air conditioning plant are discussed below.

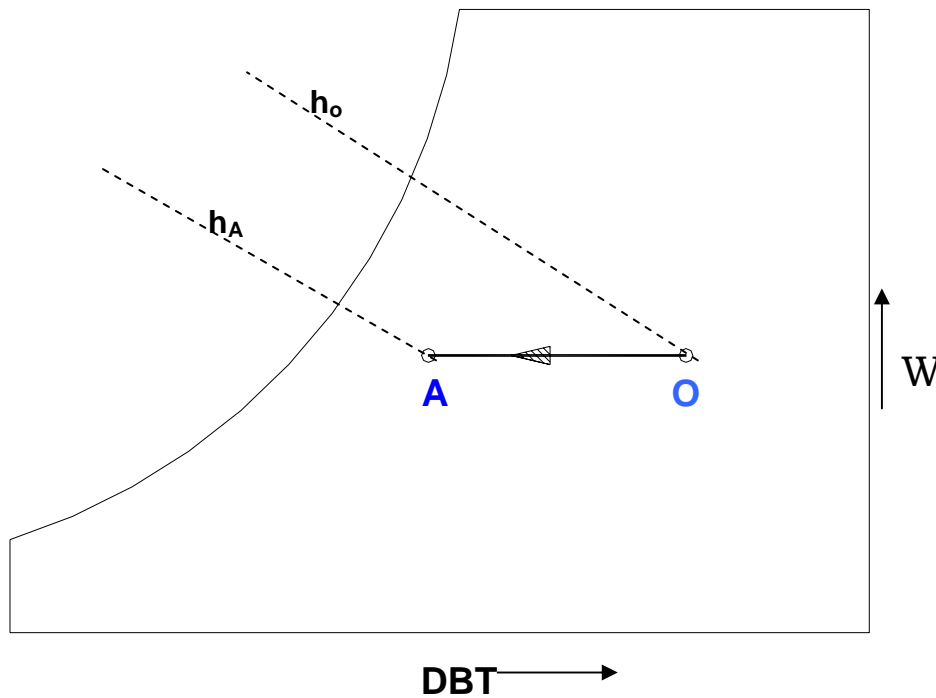
## 28.2. Important psychrometric processes:

### a) Sensible cooling:

During this process, the moisture content of air remains constant but its temperature decreases as it flows over a cooling coil. For moisture content to remain

constant, the surface of the cooling coil should be dry and its surface temperature should be greater than the dew point temperature of air. If the cooling coil is 100% effective, then the exit temperature of air will be equal to the coil temperature. However, in practice, the exit air temperature will be higher than the cooling coil temperature. Figure 28.1 shows the sensible cooling process O-A on a psychrometric chart. The heat transfer rate during this process is given by:

$$Q_c = m_a(h_O - h_A) = m_a c_{pm}(T_O - T_A) \quad (28.1)$$



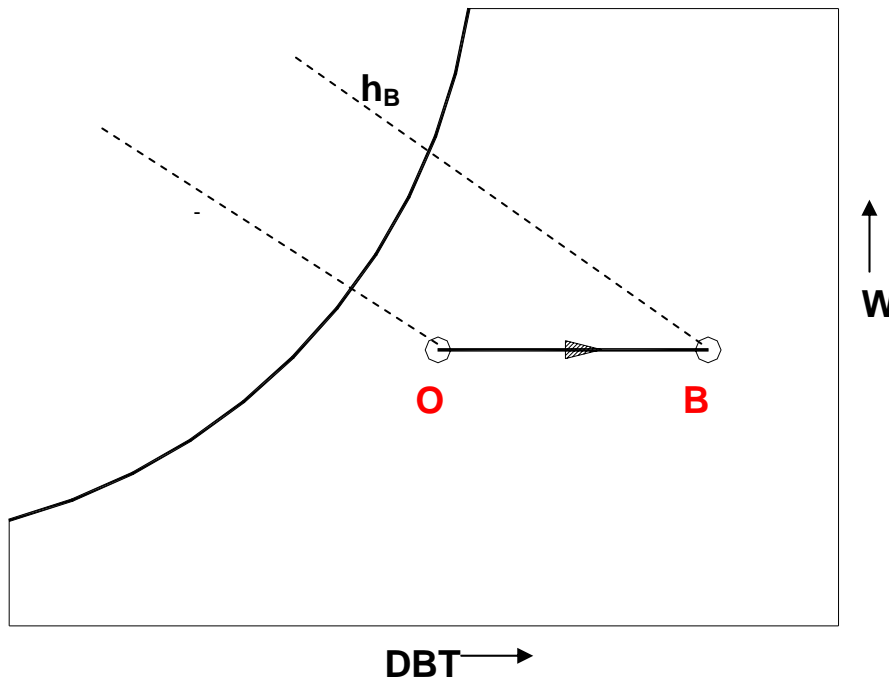
**Fig.28.1:** Sensible cooling process O-A on psychrometric chart

**b) Sensible heating (Process O-B):**

During this process, the moisture content of air remains constant and its temperature increases as it flows over a heating coil. The heat transfer rate during this process is given by:

$$Q_h = m_a(h_B - h_O) = m_a c_{pm}(T_B - T_O) \quad (28.2)$$

where  $c_{pm}$  is the humid specific heat ( $\approx 1.0216$  kJ/kg dry air) and  $m_a$  is the mass flow rate of dry air (kg/s). Figure 28.2 shows the sensible heating process on a psychrometric chart.



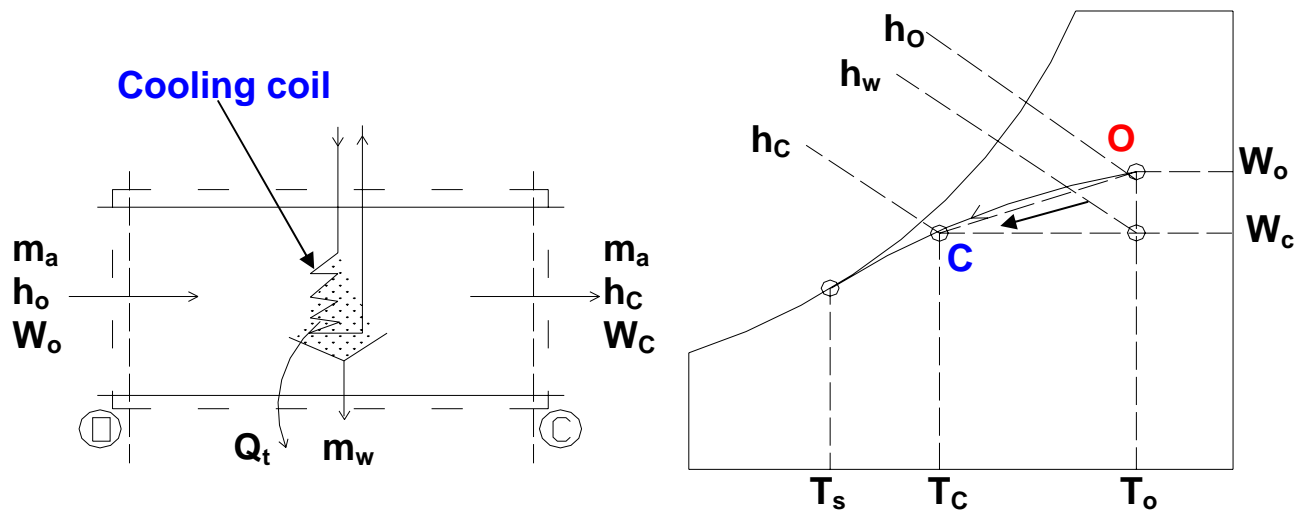
**Fig.28.2:** Sensible heating process on psychrometric chart

c) Cooling and dehumidification (Process O-C):

When moist air is cooled below its dew-point by bringing it in contact with a cold surface as shown in Fig.28.3, some of the water vapor in the air condenses and leaves the air stream as liquid, as a result both the temperature and humidity ratio of air decreases as shown. This is the process air undergoes in a typical air conditioning system. Although the actual process path will vary depending upon the type of cold surface, the surface temperature, and flow conditions, for simplicity the process line is assumed to be a straight line. The heat and mass transfer rates can be expressed in terms of the initial and final conditions by applying the conservation of mass and conservation of energy equations as given below:

By applying mass balance for the water:

$$m_a \cdot w_O = m_a \cdot w_C + m_w \quad (28.3)$$



**Fig.28.3:** Cooling and dehumidification process (O-C)

By applying energy balance:

$$m_a \cdot h_o = Q_t + m_w \cdot h_w + m_a \cdot h_c \quad (28.4)$$

from the above two equations, the load on the cooling coil,  $Q_t$  is given by:

$$Q_t = m_a (h_o - h_c) - m_a (w_o - w_c) h_w \quad (28.5)$$

the 2<sup>nd</sup> term on the RHS of the above equation is normally small compared to the other terms, so it can be neglected. Hence,

$$Q_t = m_a (h_o - h_c) \quad (28.6)$$

It can be observed that the cooling and de-humidification process involves both latent and sensible heat transfer processes, hence, the total, latent and sensible heat transfer rates ( $Q_t$ ,  $Q_l$  and  $Q_s$ ) can be written as:

$$\begin{aligned} Q_t &= Q_l + Q_s \\ \text{where } Q_l &= m_a (h_o - h_w) = m_a \cdot h_{fg} (w_o - w_c) \quad (28.7) \\ Q_s &= m_a (h_w - h_c) = m_a \cdot c_{pm} (T_o - T_c) \end{aligned}$$

By separating the total heat transfer rate from the cooling coil into sensible and latent heat transfer rates, a useful parameter called Sensible Heat Factor (SHF) is defined. SHF is defined as the ratio of sensible to total heat transfer rate, i.e.,

$$SHF = Q_s / Q_t = Q_s / (Q_s + Q_l) \quad (28.8)$$

From the above equation, one can deduce that a SHF of 1.0 corresponds to no latent heat transfer and a SHF of 0 corresponds to no sensible heat transfer. A SHF of 0.75 to 0.80 is quite common in air conditioning systems in a normal dry-climate. A

lower value of SHF, say 0.6, implies a high latent heat load such as that occurs in a humid climate.

From Fig.28.3, it can be seen that the slope of the process line O-C is given by:

$$\tan c = \frac{\Delta w}{\Delta T} \quad (28.9)$$

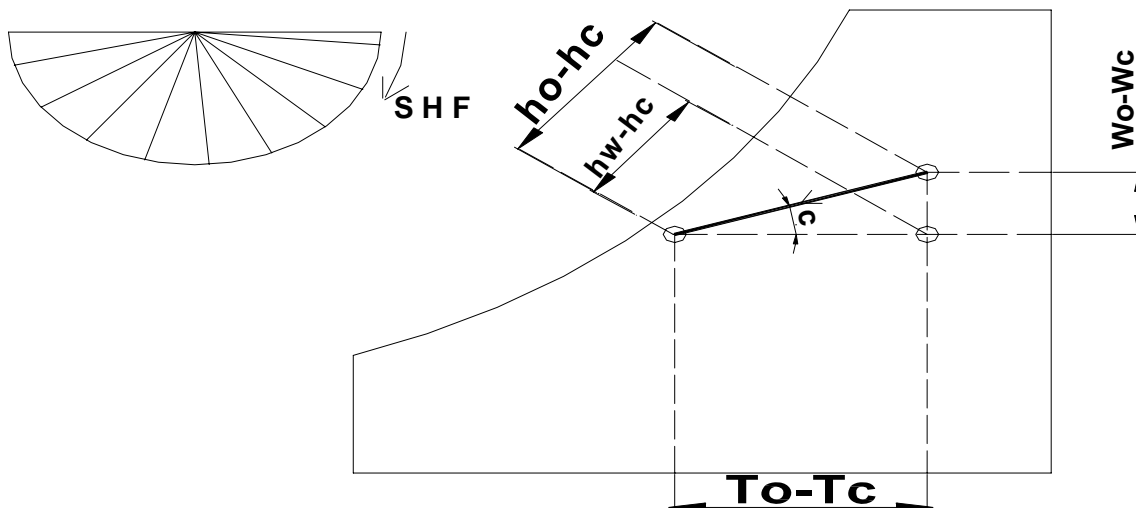
From the definition of SHF,

$$\frac{1 - \text{SHF}}{\text{SHF}} = \frac{Q_l}{Q_s} = \frac{m_a h_{fg} \Delta w}{m_a c_{pm} \Delta T} = \frac{2501 \Delta w}{1.0216 \Delta T} = 2451 \frac{\Delta w}{\Delta T} \quad (28.10)$$

From the above equations, we can write the slope as:

$$\tan c = \frac{1}{2451} \left( \frac{1 - \text{SHF}}{\text{SHF}} \right) \quad (28.11)$$

Thus we can see that the slope of the cooling and de-humidification line is purely a function of the sensible heat factor, SHF. Hence, we can draw the cooling and de-humidification line on psychrometric chart if the initial state and the SHF are known. In some standard psychrometric charts, a protractor with different values of SHF is provided. The process line is drawn through the initial state point and in parallel to the given SHF line from the protractor as shown in Fig.28.4.



**Fig.28.4:** A psychrometric chart with protractor for SHF lines

In Fig.28.3, the temperature  $T_s$  is the effective surface temperature of the cooling coil, and is known as apparatus dew-point (ADP) temperature. In an ideal situation, when all the air comes in perfect contact with the cooling coil surface, then the exit temperature of air will be same as ADP of the coil. However, in actual case the exit temperature of air will always be greater than the apparatus dew-point temperature due to boundary layer development as air flows over the cooling coil surface and also due to

temperature variation along the fins etc. Hence, we can define a by-pass factor (BPF) as:

$$\text{BPF} = \frac{T_c - T_s}{T_o - T_s} \quad (28.12)$$

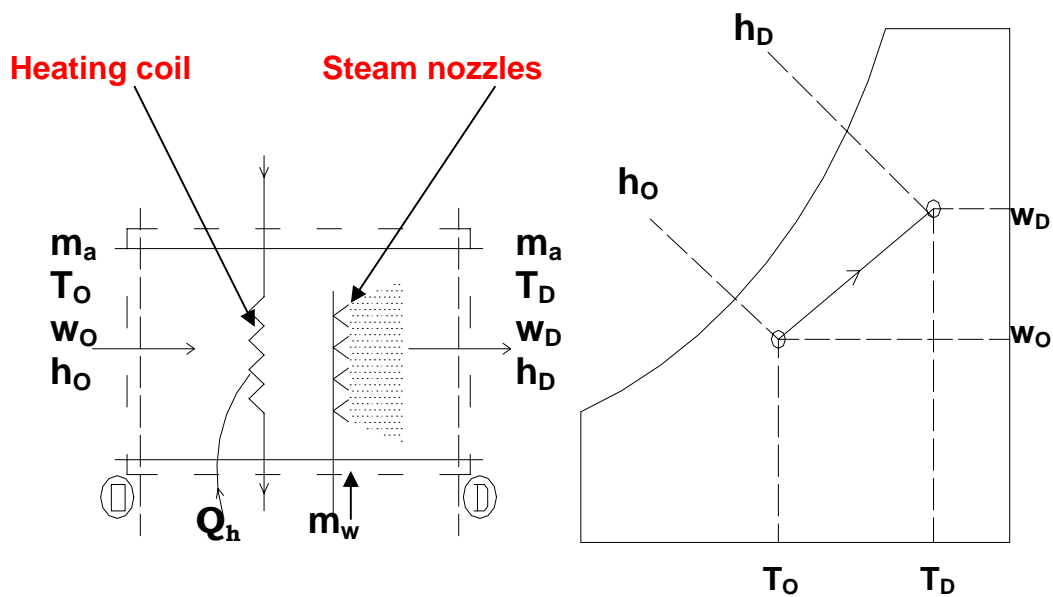
It can be easily seen that, higher the by-pass factor larger will be the difference between air outlet temperature and the cooling coil temperature. When BPF is 1.0, all the air by-passes the coil and there will not be any cooling or de-humidification. In practice, the by-pass factor can be increased by increasing the number of rows in a cooling coil or by decreasing the air velocity or by reducing the fin pitch.

Alternatively, a contact factor(CF) can be defined which is given by:

$$\text{CF} = 1 - \text{BPF} \quad (28.13)$$

d) Heating and Humidification (Process O-D):

During winter it is essential to heat and humidify the room air for comfort. As shown in Fig.28.5., this is normally done by first sensibly heating the air and then adding water vapour to the air stream through steam nozzles as shown in the figure.



**Fig.28.5:** Heating and humidification process

Mass balance of water vapor for the control volume yields the rate at which steam has to be added, i.e.,  $m_w$ :

$$m_w = m_a(w_D - w_O) \quad (28.14)$$

where  $m_a$  is the mass flow rate of dry air.

From energy balance:

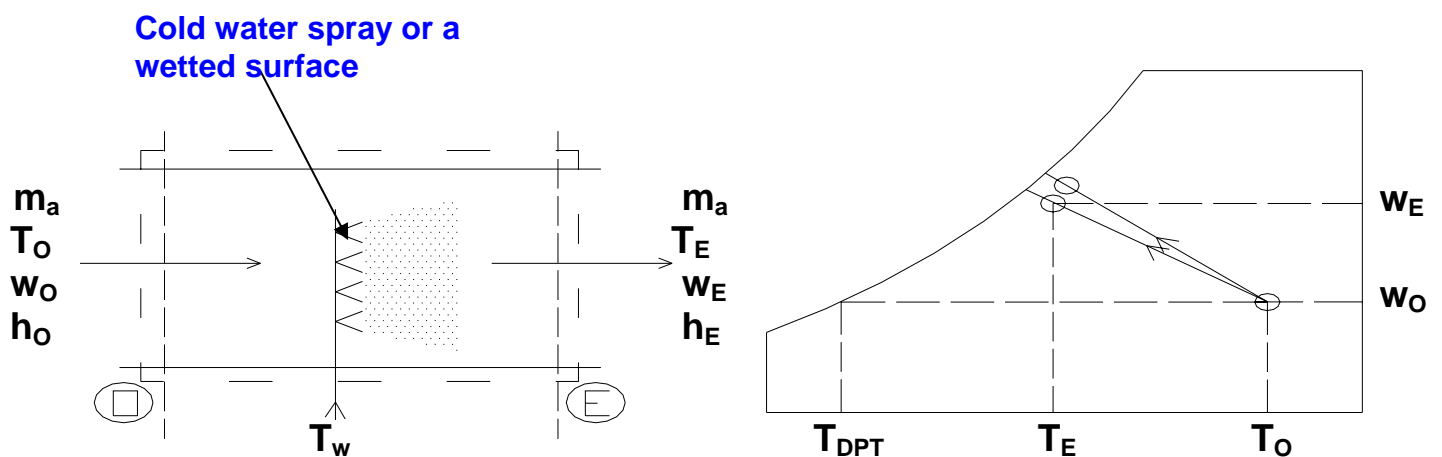
$$Q_h = m_a(h_D - h_O) - m_w h_w \quad (28.15)$$

where  $Q_h$  is the heat supplied through the heating coil and  $h_w$  is the enthalpy of steam.

Since this process also involves simultaneous heat and mass transfer, we can define a sensible heat factor for the process in a way similar to that of a cooling and dehumidification process.

e) Cooling & humidification (Process O-E):

As the name implies, during this process, the air temperature drops and its humidity increases. This process is shown in Fig.28.6. As shown in the figure, this can be achieved by spraying cool water in the air stream. The temperature of water should be lower than the dry-bulb temperature of air but higher than its dew-point temperature to avoid condensation ( $T_{DPT} < T_w < T_O$ ).



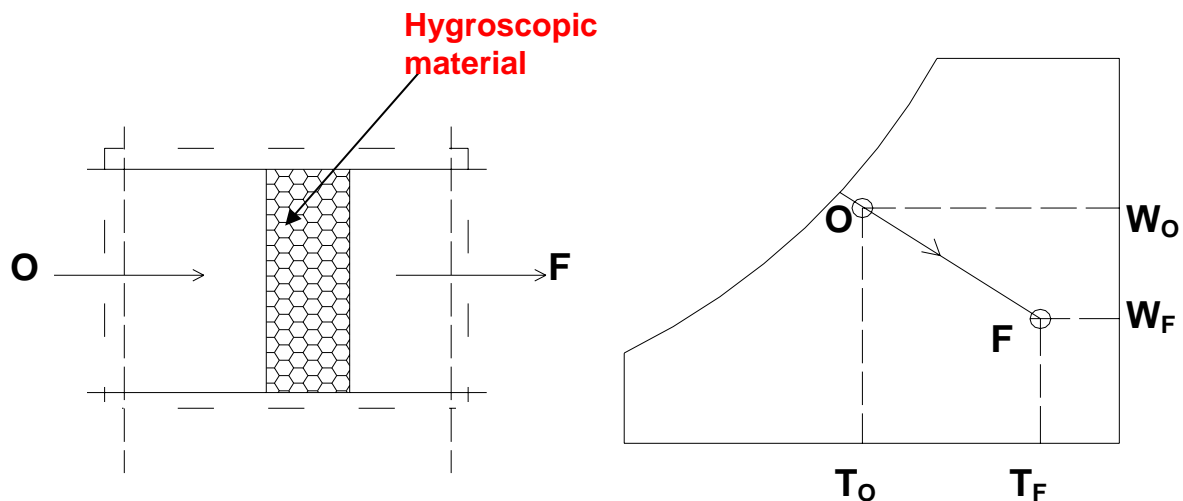
**Fig.28.6:** Cooling and humidification process

It can be seen that during this process there is sensible heat transfer from air to water and latent heat transfer from water to air. Hence, the total heat transfer depends upon the water temperature. If the temperature of the water sprayed is equal to the wet-bulb temperature of air, then the net transfer rate will be zero as the sensible heat transfer from air to water will be equal to latent heat transfer from water to air. If the water temperature is greater than WBT, then there will be a net heat transfer from water to air. If the water temperature is less than WBT, then the net heat transfer will be from air to water. Under a special case when the spray water is entirely recirculated and is neither heated nor cooled, the system is perfectly insulated and the make-up water is supplied at WBT, then at steady-state, the air undergoes an adiabatic saturation process, during which its WBT remains constant. This is the process of adiabatic saturation discussed in Chapter 27. The process of cooling and humidification is encountered in a wide variety of devices such as evaporative coolers, cooling towers etc.



f) Heating and de-humidification (Process O-F):

This process can be achieved by using a hygroscopic material, which absorbs or adsorbs the water vapor from the moisture. If this process is thermally isolated, then the enthalpy of air remains constant, as a result the temperature of air increases as its moisture content decreases as shown in Fig.28.7. This hygroscopic material can be a solid or a liquid. In general, the absorption of water by the hygroscopic material is an exothermic reaction, as a result heat is released during this process, which is transferred to air and the enthalpy of air increases.



**Fig.28.7.** Chemical de-humidification process

g) Mixing of air streams:

Mixing of air streams at different states is commonly encountered in many processes, including in air conditioning. Depending upon the state of the individual streams, the mixing process can take place with or without condensation of moisture.

i) Without condensation: Figure 28.8 shows an adiabatic mixing of two moist air streams during which no condensation of moisture takes place. As shown in the figure, when two air streams at state points 1 and 2 mix, the resulting mixture condition 3 can be obtained from mass and energy balance.

From the mass balance of dry air and water vapor:

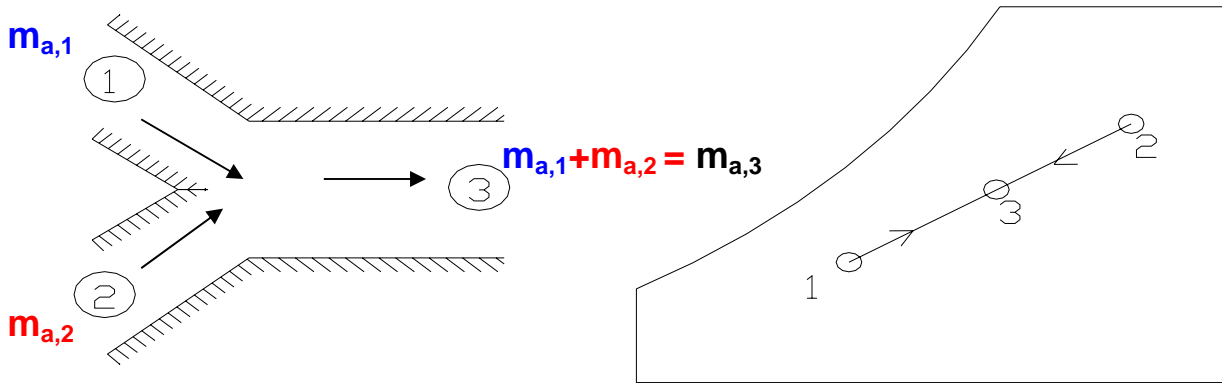
$$m_{a,1}w_1 + m_{a,2}w_2 = m_{a,3}w_3 = (m_{a,1} + m_{a,2})w_3 \quad (28.16)$$

From energy balance:

$$m_{a,1}h_1 + m_{a,2}h_2 = m_{a,3}h_3 = (m_{a,1} + m_{a,2})h_3 \quad (28.17)$$

From the above equations, it can be observed that the final enthalpy and humidity ratio of mixture are weighted averages of inlet enthalpies and humidity ratios. A generally valid approximation is that the final temperature of the mixture is the

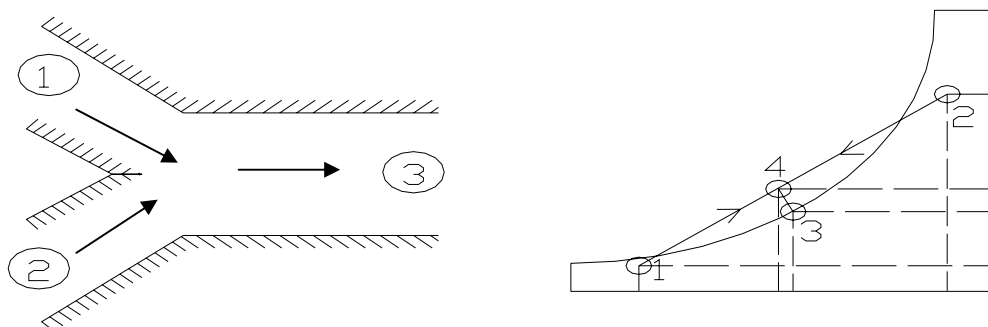
weighted average of the inlet temperatures. With this approximation, the point on the psychrometric chart representing the mixture lies on a straight line connecting the two inlet states. Hence, the ratio of distances on the line, i.e.,  $(1-3)/(2-3)$  is equal to the ratio of flow rates  $m_{a,2}/m_{a,1}$ . The resulting error (due to the assumption that the humid specific heats being constant) is usually less than 1 percent.



**Fig.28.8.** Mixing of two air streams without condensation

ii) Mixing with condensation:

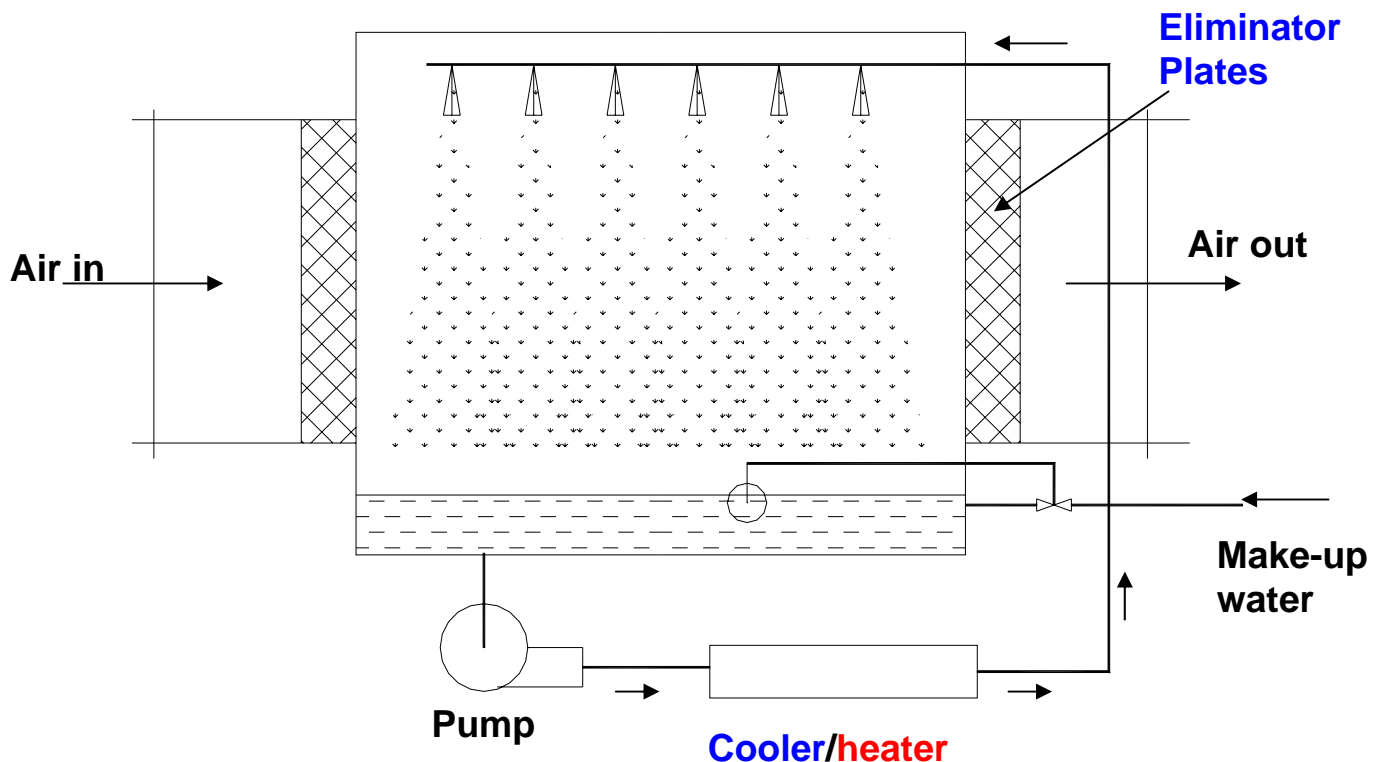
As shown in Fig.28.9, when very cold and dry air mixes with warm air at high relative humidity, the resulting mixture condition may lie in the two-phase region, as a result there will be condensation of water vapor and some amount of water will leave the system as liquid water. Due to this, the humidity ratio of the resulting mixture (point 3) will be less than that at point 4. Corresponding to this will be an increase in temperature of air due to the release of latent heat of condensation. This process rarely occurs in an air conditioning system, but this is the phenomenon which results in the formation of fog or frost (if the mixture temperature is below  $0^{\circ}\text{C}$ ). This happens in winter when the cold air near the earth mixes with the humid and warm air, which develops towards the evening or after rains.



**Fig.28.9.** Mixing of two air streams with condensation

### 28.3. Air Washers:

An air washer is a device for conditioning air. As shown in Fig.28.10, in an air washer air comes in direct contact with a spray of water and there will be an exchange of heat and mass (water vapour) between air and water. The outlet condition of air depends upon the temperature of water sprayed in the air washer. Hence, by controlling the water temperature externally, it is possible to control the outlet conditions of air, which then can be used for air conditioning purposes.



**Fig.28.10: Air washer**

In the air washer, the mean temperature of water droplets in contact with air decides the direction of heat and mass transfer. As a consequence of the 2<sup>nd</sup> law, the heat transfer between air and water droplets will be in the direction of decreasing temperature gradient. Similarly, the mass transfer will be in the direction of decreasing vapor pressure gradient. For example,

a) Cooling and dehumidification:  $t_w < t_{DPT}$ . Since the exit enthalpy of air is less than its inlet value, from energy balance it can be shown that there is a transfer of total energy from air to water. Hence to continue the process, water has to be externally cooled. Here both latent and sensible heat transfers are from air to water. This is shown by Process O-A in Fig.28.11.

b) Adiabatic saturation:  $t_w = t_{WBT}$ . Here the sensible heat transfer from air to water is exactly equal to latent heat transfer from water to air. Hence, no external cooling or heating of water is required. That is this is a case of pure water recirculation. This is

shown by Process O-B in Fig.28.11. This is the process that takes place in a perfectly insulated evaporative cooler.

c) Cooling and humidification:  $t_{DPT} < t_w < t_{WBT}$ . Here the sensible heat transfer is from air to water and latent heat transfer is from water to air, but the total heat transfer is from air to water, hence, water has to be cooled externally. This is shown by Process O-C in Fig.28.11.

d) Cooling and humidification:  $t_{WBT} < t_w < t_{DBT}$ . Here the sensible heat transfer is from air to water and latent heat transfer is from water to air, but the total heat transfer is from water to air, hence, water has to be heated externally. This is shown by Process O-D in Fig.28.11. This is the process that takes place in a cooling tower. The air stream extracts heat from the hot water coming from the condenser, and the cooled water is sent back to the condenser.

e) Heating and humidification:  $t_w > t_{DBT}$ . Here both sensible and latent heat transfers are from water to air, hence, water has to be heated externally. This is shown by Process O-E in Fig.28.11.

Thus, it can be seen that an air washer works as a year-round air conditioning system. Though air washer is a and extremely useful simple device, it is not commonly used for comfort air conditioning applications due to concerns about health resulting from bacterial or fungal growth on the wetted surfaces. However, it can be used in industrial applications.

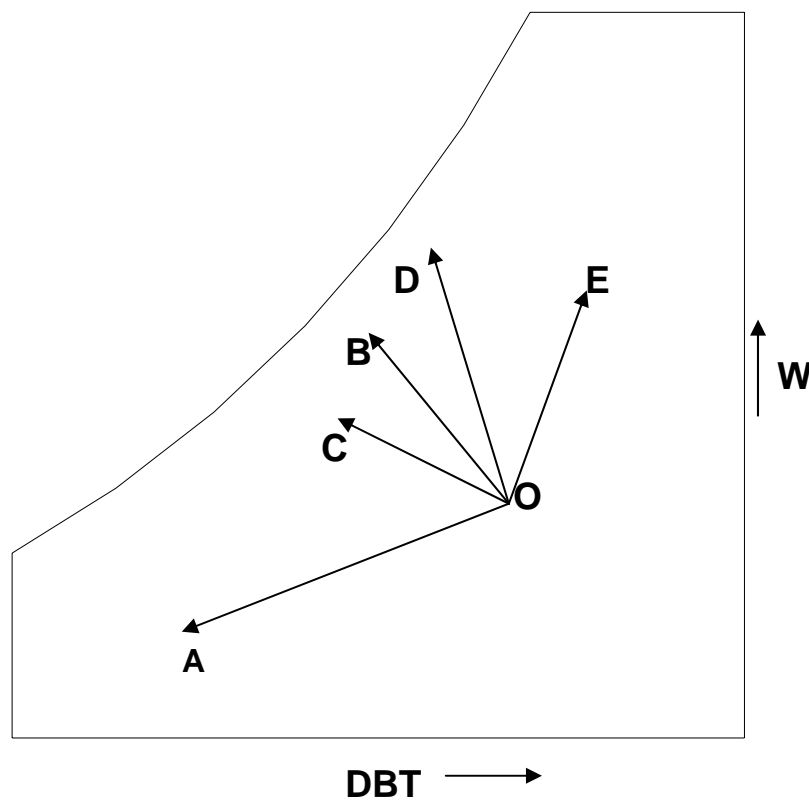


Fig.28.11: Various psychrometric processes that can take place in an air washer

## 28.4. Enthalpy potential:

As shown in case of an air washer, whenever water (or a wetted surface) and air contact each other, there is possibility of heat and moisture transfer between them. The directions of heat and moisture transfer depend upon the temperature and vapor pressure differences between air and water. As a result, the direction of the total heat transfer rate, which is a sum of sensible heat transfer and latent heat transfers also depends upon water and air conditions. The concept of enthalpy potential is very useful in quantifying the total heat transfer in these processes and its direction.

The sensible ( $Q_S$ ) and latent ( $Q_L$ ) heat transfer rates are given by:

$$\begin{aligned} Q_S &= h_C A_S (t_i - t_a) \\ Q_L &= \dot{m}_w \cdot h_{fg} = h_D \cdot A_S (w_i - w_a) \cdot h_{fg} \end{aligned} \quad (28.18)$$

the total heat transfer  $Q_T$  is given by:

$$Q_T = Q_S + Q_L = h_C A_S (t_i - t_a) + h_D \cdot A_S (w_i - w_a) \cdot h_{fg} \quad (28.19)$$

where  $t_a$  = dry-bulb temperature of air, °C

$t_i$  = temperature of water/wetted surface, °C

$w_a$  = humidity ratio of air, kg/kg

$w_i$  = humidity ratio of saturated air at  $t_i$ , kg/kg

$h_c$  = convective heat transfer coefficient,  $W/m^2 \cdot ^\circ C$

$h_D$  = convective mass transfer coefficient,  $kg/m^2$

$h_{fg}$  = latent heat of vaporization, J/kg

Since the transport mechanism that controls the convective heat transfer between air and water also controls the moisture transfer between air and water, there exists a relation between heat and mass transfer coefficients,  $h_c$  and  $h_D$  as discussed in an earlier chapter. It has been shown that for air-water vapor mixtures,

$$h_D \approx \frac{h_c}{c_{pm}} \quad \text{or} \quad \frac{h_c}{h_D \cdot c_{pm}} = \text{Lewis number} \approx 1.0 \quad (28.20)$$

where  $c_{pm}$  is the humid specific heat  $\approx 1.0216$  kJ/kg.K.

Hence the total heat transfer is given by:

$$Q_T = Q_S + Q_L = \frac{h_C A_S}{c_{pm}} [(t_i - t_a) + (w_i - w_a) \cdot h_{fg}] \quad (28.21)$$

by manipulating the term in the parenthesis of RHS, it can be shown that:

$$Q_T = Q_S + Q_L = \frac{h_c A_s}{c_{pm}} [(h_i - h_a)] \quad (28.22)$$

thus the total heat transfer and its direction depends upon the enthalpy difference (or potential) between water and air ( $h_i - h_a$ ).

**if  $h_i > h_a$ ;** then the total heat transfer is from water to air and water gets cooled

**if  $h_i < h_a$ ;** then the total heat transfer is from air to water and water gets heated

**if  $h_i = h_a$ ;** then the net heat transfer is zero, i.e., the sensible heat transfer rate is equal to but in the opposite direction of latent heat transfer. Temperature of water remains at its wet bulb temperature value

The concept of enthalpy potential is very useful in psychrometric calculations and is frequently used in the design and analysis of evaporative coolers, cooling towers, air washers etc.

### Questions and answers:

1. Which of the following statements are TRUE?

- a) During sensible cooling of air, both dry bulb and wet bulb temperatures decrease
- b) During sensible cooling of air, dry bulb temperature decreases but wet bulb temperature remains constant
- c) During sensible cooling of air, dry and wet bulb temperatures decrease but dew point temperature remains constant
- d) During sensible cooling of air, dry bulb, wet bulb and dew point temperatures decrease

**Ans.: a) and c)**

2. Which of the following statements are TRUE?

- a) The sensible heat factor for a sensible heating process is 1.0
- b) The sensible heat factor for a sensible cooling process is 0.0
- c) Sensible heat factor always lies between 0.0 and 1.0
- d) Sensible heat factor is low for air conditioning plants operating in humid climates

**Ans.: a) and d)**

3. Which of the following statements are TRUE?

- a) As the by-pass factor (BPF) of the cooling coil increases, temperature difference between air at the outlet of the coil and coil ADP decreases
- b) The BPF of the coil increases as the velocity of air through the coil increases
- c) The BPF of the coil increases as the fin pitch increases
- d) The BPF of the coil decreases as the number of rows in the flow direction increase

**Ans.: b), c) and d)**

4. Which of the following statements are TRUE?

- a) During cooling and humidification process, the enthalpy of air decreases
- b) During cooling and humidification process, the enthalpy of air increases
- c) During cooling and humidification process, the enthalpy of air remains constant
- d) During cooling and humidification process, the enthalpy of air may increase, decrease or remain constant depending upon the temperature of the wet surface

**Ans.: d)**

5. An air stream at a flow rate of 1 kg/s and a DBT of 30°C mixes adiabatically with another air stream flowing with a mass flow rate of 2 kg/s and at a DBT of 15°C. Assuming no condensation to take place, the temperature of the mixture is approximately equal to:

- a) 20°C
- b) 22.5°C
- c) 25°C
- d) Cannot be found

**Ans.: a)**

6. Which of the following statements are TRUE?

- a) In an air washer, water has to be externally cooled if the temperature at which it is sprayed is equal to the dry bulb temperature of air
- b) In an air washer, water has to be externally heated if the temperature at which it is sprayed is equal to the dry bulb temperature of air
- c) In an air washer, if water is simply recirculated, then the enthalpy of air remains nearly constant at steady state

d) In an air washer, if water is simply recirculated, then the moisture content of air remains nearly constant at steady state

**Ans.: b) and c)**

7. Which of the following statements are TRUE?

a) When the enthalpy of air is equal to the enthalpy of saturated air at the wetted surface temperature, then there is no sensible heat transfer between air and the wetted surface

b) When the enthalpy of air is equal to the enthalpy of saturated air at the wetted surface temperature, then there is no latent heat transfer between air and the wetted surface

c) When the enthalpy of air is equal to the enthalpy of saturated air at the wetted surface temperature, then there is no net heat transfer between air and the wetted surface

d) When the enthalpy of air is equal to the enthalpy of saturated air at the wetted surface temperature, then the wet bulb temperature of air remains constant

**Ans.: c) and d)**

8. What is the required wattage of an electrical heater that heats 0.1 m<sup>3</sup>/s of air from 15°C and 80% RH to 55°C? The barometric pressure is 101.325 kPa.

**Ans.:** Air undergoes sensible heating as it flows through the electrical heater

From energy balance, the required heater wattage (W) is given by:

$$W = m_a(h_e - h_i) \approx (V_a/v_a) \cdot c_{pm}(T_e - T_i)$$

Where  $V_a$  is the volumetric flow rate of air in m<sup>3</sup>/s and  $v_a$  is the specific volume of dry air.  $T_e$  and  $T_i$  are the exit and inlet temperatures of air and  $c_{pm}$  is the average specific heat of moist air ( $\approx 1021.6 \text{ J/kg.K}$ ).

Using perfect gas model, the specific volume of dry air is found to be:

$$v_a = (R_a \cdot T / P_a) = (R_a \cdot T / (P_t - P_v))$$

At 15°C and 80% RH, the vapour pressure  $p_v$  is found to be 1.364 kPa using psychrometric chart or equations.

Substituting the values of  $R_a$ ,  $T$ ,  $p_t$  and  $p_v$  in the equation for specific volume, we find the value of specific volume to be **0.8274 m<sup>3</sup>/kg**

$$\therefore \text{Heater wattage, } W \approx (V_a/v_a) \cdot c_{pm}(T_e - T_i) = (0.1/0.8274) \times 1021.6(55 - 15) = 4938.8 \text{ W}$$

**(ans.)**



9. 0.2 kg/s of moist air at 45°C (DBT) and 10% RH is mixed with 0.3 kg/s of moist air at 25°C and a humidity ratio of 0.018 kgw/kgda in an adiabatic mixing chamber. After mixing, the mixed air is heated to a final temperature of 40°C using a heater. Find the temperature and relative humidity of air after mixing. Find the heat transfer rate in the heater and relative humidity of air at the exit of heater. Assume the barometric pressure to be 1 atm.

**Ans.:** Given:

Stream 1: mass flow rate,  $m_1 = 0.2$  kg/s;  $T_1 = 45^\circ\text{C}$  and RH = 10%.

Using psychrometric equations or psychrometric chart, the humidity ratio and enthalpy of stream 1 are found to be:

$$\mathbf{W_1 = 0.006 \text{ kgw/kgda} \ \& \ h_1 = 61.0 \text{ kJ/kgda}}$$

Stream 2: mass flow rate,  $m_2 = 0.3$  kg/s;  $T_2 = 25^\circ\text{C}$  and  $W_2 = 0.018$  kgw/kgda

Using psychrometric equations or psychrometric chart, enthalpy of stream 2 is found to be:

$$\mathbf{h_2 = 71.0 \text{ kJ/kgda}}$$

For the adiabatic mixing process, from mass balance:

$$\mathbf{W_3 = \frac{m_{a,1}w_1 + m_{a,2}w_2}{m_{a,1} + m_{a,2}} = \frac{0.2 \times 0.006 + 0.3 \times 0.018}{0.2 + 0.3} = 0.0132 \text{ kgw / kgda}}$$

From energy balance (assuming the specific heat of moist air to remain constant):

$$\mathbf{T_3 = \frac{m_{a,1}T_1 + m_{a,2}T_2}{m_{a,1} + m_{a,2}} = \frac{0.2 \times 45 + 0.3 \times 25}{0.2 + 0.3} = 33^\circ\text{C} \quad (\text{ans.})}$$

From  $T_3$  and  $W_3$ , the relative humidity of air after mixing is found to be:

$$\mathbf{RH_3 = 41.8\% \quad (\text{ans.})}$$

For the sensible heating process in the heater:

$$\mathbf{Q_s = m_a(h_e - h_i) \approx m_a \cdot c_{pm}(T_e - T_i) = 0.5 \times 1.0216(40 - 33) = 3.5756 \text{ kW} \quad (\text{ans.})}$$

The relative humidity at the exit of heater is obtained from the values of DBT (40°C) and humidity ratio (0.0132 kgw/kgda) using psychrometric chart/equations. This is found to be:

$$\mathbf{RH \text{ at } 40^\circ\text{C} \text{ and } 0.0132 \text{ kgw/kgda} = 28.5 \% \quad (\text{ans.})}$$

**10.** A cooling tower is used for cooling the condenser water of a refrigeration system having a heat rejection rate of 100 kW. In the cooling tower air enters at 35°C (DBT) and 24°C (WBT) and leaves the cooling tower at a DBT of 26°C relative humidity of 95%. What is the required flow rate of air at the inlet to the cooling tower in m<sup>3</sup>/s. What is the amount of make-up water to be supplied? The temperature of make-up water is at 30°C, at which its enthalpy ( $h_w$ ) may be taken as 125.4 kJ/kg. Assume the barometric pressure to be 1 atm.

**Ans.:**

At the inlet to cooling tower: DBT = 35°C and WBT = 24°C

From psychrometric chart/equations the following values are obtained for the inlet:

**Humidity ratio,  $W_i = 0.01426$  kgw/kgda**

**Enthalpy,  $h_i = 71.565$  kJ/kgda**

**Sp. volume,  $v_i = 0.89284$  m<sup>3</sup>/kgda**

At the outlet to cooling tower: DBT = 26°C and RH = 95%

From psychrometric chart/equations the following values are obtained for the outlet:

**Humidity ratio,  $W_o = 0.02025$  kgw/kgda**

**Enthalpy,  $h_o = 77.588$  kJ/kgda**

From mass and energy balance across the cooling tower:

$$Q_c = m_a\{(h_o - h_i) - (W_o - W_i)h_w\} = 100 \text{ kW}$$

Substituting the values of enthalpy and humidity ratio at the inlet and outlet of cooling tower and enthalpy of make-up water in the above expression, we obtain:

$$m_a = 18.97 \text{ kg/s,}$$

**hence, the volumetric flow rate,  $V_i = m_a \times v_i = 16.94$  m<sup>3</sup>/s (ans.)**

Amount of make-up water required  $m_w$  is obtained from mass balance as:

$$m_w = m_a(W_o - W_i) = 18.97(0.02025 - 0.01426) = 0.1136 \text{ kg/s} = 113.6 \text{ grams/s (ans.)}$$

**11.** In an air conditioning system air at a flow rate of 2 kg/s enters the cooling coil at 25°C and 50% RH and leaves the cooling coil at 11°C and 90% RH. The apparatus dew point of the cooling coil is 7°C. Find a) The required cooling capacity of the coil, b) Sensible Heat Factor for the process, and c) By-pass factor of the cooling coil. Assume the barometric pressure to be 1 atm. Assume the condensate water to leave the coil at ADP ( $h_w = 29.26$  kJ/kg)

**Ans.:** At the inlet to the cooling coil;  $T_i = 25^\circ\text{C}$  and RH = 50%

From psychrometric chart;  $W_i = 0.00988$  kgw/kgda and  $h_i = 50.155$  kJ/kgda

At the outlet of the cooling coil;  $T_o = 11^\circ\text{C}$  and  $\text{RH} = 90\%$

From psychrometric chart;  $W_o = 0.00734 \text{ kgw/kgda}$  and  $h_o = 29.496 \text{ kJ/kgda}$

a) From mass balance across the cooling coil, the condensate rate,  $m_w$  is:

$$m_w = m_a(W_i - W_o) = 2.0(0.00988 - 0.00734) = 0.00508 \text{ kg/s}$$

From energy balance across the cooling tower, the required capacity of the cooling coil,  $Q_c$  is given by::

$$Q_c = m_a(h_i - h_o) - m_w \cdot h_w = 2.0(50.155 - 29.496) - 0.00508 \times 29.26 = 41.17 \text{ kW (ans.)}$$

b) The sensible heat transfer rate,  $Q_s$  is given by:

$$Q_s = m_a c_{pm}(T_i - T_o) = 2.0 \times 1.0216 \times (25 - 11) = 28.605 \text{ kW}$$

The latent heat transfer rate,  $Q_l$  is given by:

$$Q_l = m_a h_{fg}(W_i - W_o) = 2.0 \times 2501.0 \times (0.00988 - 0.00734) = 12.705 \text{ kW}^1$$

The Sensible Heat Factor (SHF) is given by:

$$\text{SHF} = Q_s / (Q_s + Q_l) = 28.605 / (28.605 + 12.705) = 0.692 \quad (\text{ans.})$$

c) From its definition, the by-pass factor of the coil, BPF is given by:

$$\text{BPF} = (T_o - \text{ADP}) / (T_i - \text{ADP}) = (11 - 7) / (25 - 7) = 0.222 \quad (\text{ans.})$$

---

<sup>1</sup> The small difference between  $Q_c$  and  $(Q_s + Q_l)$  is due to the use of average values for specific heat,  $c_{pm}$  and latent heat of vaporization,  $h_{fg}$ .

# Lesson 29 Inside And Outside Design Conditions

## The specific objectives of this lecture are to:

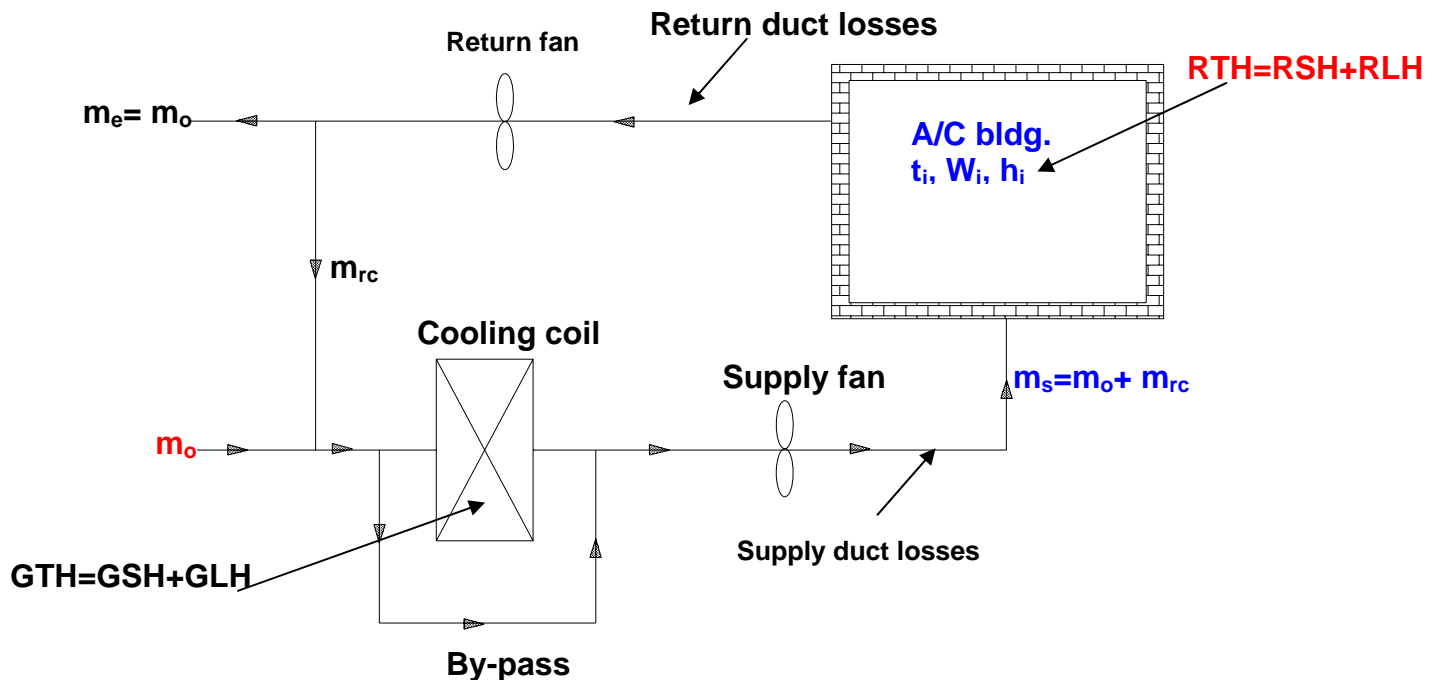
1. Describe a typical air conditioning system and discuss the need for fixing suitable indoor and outdoor design conditions (*Section 29.1*)
2. Discuss the criteria used for selecting inside design conditions (*Section 29.2*)
3. Define thermal comfort, metabolic rate and response of human beings to variation in body temperature (*Section 29.3*)
4. Present heat balance equation, equations for convective, radiative and evaporative losses from the skin, metabolic rates for various types of activities and discuss the thermo-regulatory mechanism used by human body to fight against heat and cold (*Section 29.4*)
5. Discuss the factors affecting thermal comfort (*Section 29.5*)
6. Discuss the various thermal indices used for evaluating indoor environment and present ASHRAE comfort chart, recommended inside design conditions and discuss the concept of Predicted Mean Vote (PMV) and Percent of People Dissatisfied (PPD) (*Section 29.6*)
7. Discuss the criteria used for selecting outside design conditions and present typical summer design conditions for major Indian cities as suggested by ASHRAE (*Section 29.7*)

At the end of the lecture, the student should be able to:

1. Explain the need for selecting design inside and outside conditions with respect to a typical air conditioning system
2. Define thermal comfort, metabolism, metabolic rate and discuss the effects of variation in body temperatures on human beings
3. Write the heat balance and heat transfer equations from a human body and using these equations, estimate various heat transfer rates
4. List the factors affecting thermal comfort
5. Define the various thermal indices used in evaluating indoor environment
6. Draw the ASHRAE comfort chart and mark the comfort zones for summer and winter conditions
7. Select suitable indoor design conditions based on comfort criteria
8. Define PMV and PPD and explain their significance
9. Explain the method followed for selecting suitable outside design conditions

## 29.1. Introduction:

Design and analysis of air conditioning systems involves selection of suitable inside and outside design conditions, estimation of the required capacity of cooling or heating equipment, selection of suitable cooling/heating system, selecting supply conditions, design of air transmission and distribution systems etc. Generally, the inputs are the building specifications and its usage pattern and any other special requirements. Figure 29.1 shows the schematic of a basic summer air conditioning system. As shown in the figure, under a typical summer condition, the building gains sensible and latent heats from the surroundings and also due to internal heat sources (RSH and RLH). The supply air to the building extracts the building heat gains from the conditioned space. These heat gains along with other heat gains due to ventilation, return ducts etc. have to be extracted from the air stream by the cooling coil, so that air at required cold and dry condition can be supplied to the building to complete the cycle. In general, the sensible and latent heat transfer rates (GSH and GLH) on the cooling coil are larger than the building heat gains due to the need for ventilation and return duct losses. To estimate the required cooling capacity of the cooling coil (GTH), it is essential to estimate the building and other heat gains. The building heat gains depend on the type of the building, outside conditions and the required inside conditions. Hence selection of suitable inside and outside design conditions is an important step in the design and analysis of air conditioning systems.



*Fig.29.1: Schematic of a basic summer air conditioning system*

## 29.2. Selection of inside design conditions:

The required inside design conditions depend on the intended use of the building. Air conditioning is required either for providing suitable comfort conditions for the occupants (e.g. comfort air conditioning), or for providing suitable conditions for storage of perishable products (e.g. in cold storages) or conditions for a process to take place or for products to be manufactured (e.g. industrial air conditioning). The required inside conditions for cold storage and industrial air conditioning applications vary widely depending on the specific requirement. However, the required inside conditions for comfort air conditioning systems remain practically same irrespective of the size, type, location, use of the air conditioning building etc., as this is related to the thermal comfort of the human beings.

## 29.3. Thermal comfort:

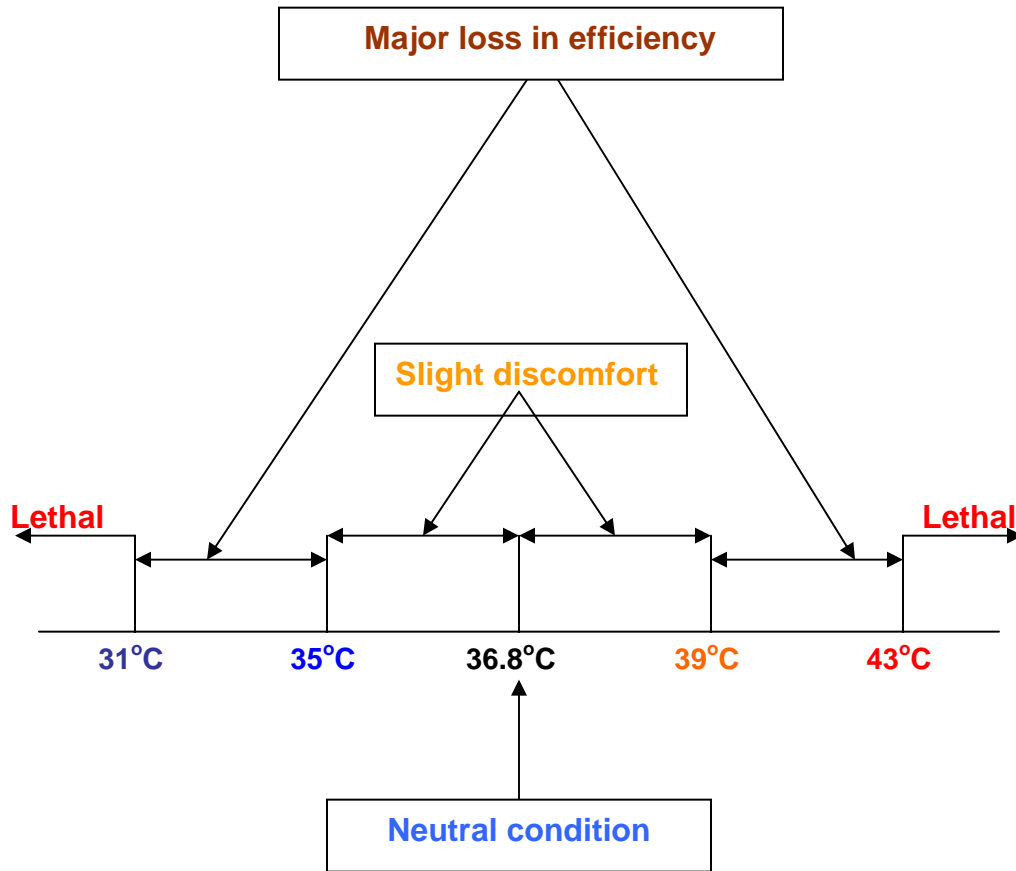
Thermal comfort is defined as “that condition of mind which expresses satisfaction with the thermal environment”. This condition is also some times called as “neutral condition”, though in a strict sense, they are not necessarily same. A living human body may be likened to a heat engine in which the chemical energy contained in the food it consumes is continuously converted into work and heat. The process of conversion of chemical energy contained in food into heat and work is called as “metabolism”. The rate at which the chemical energy is converted into heat and work is called as “metabolic rate”. Knowledge of metabolic rate of the occupants is required as this forms a part of the cooling load of the air conditioned building. Similar to a heat engine, one can define thermal efficiency of a human being as the ratio of useful work output to the energy input. The thermal efficiency of a human being can vary from 0% to as high as 15-20% for a short duration. By the manner in which the work is defined, for most of the light activities the useful work output of human beings is zero, indicating a thermal efficiency of 0%. Irrespective of the work output, a human body continuously generates heat at a rate varying from about 100 W (e.g. for a sedentary person) to as high as 2000 W (e.g. a person doing strenuous exercise). Continuous heat generation is essential, as the temperature of the human body has to be maintained within a narrow range of temperature, irrespective of the external surroundings.

A human body is very sensitive to temperature. The body temperature must be maintained within a narrow range to avoid discomfort, and within a somewhat wider range, to avoid danger from heat or cold stress. Studies show that at neutral condition, the temperatures should be:

**Skin temperature,  $t_{\text{skin}} \approx 33.7^{\circ}\text{C}$**

**Core temperature,  $t_{\text{core}} \approx 36.8^{\circ}\text{C}$**

At other temperatures, the body will feel discomfort or it may even become lethal. It is observed that when the core temperature is between 35 to 39°C, the body experiences only a mild discomfort. When the temperature is lower than 35°C or higher than 39°C, then people suffer major loss in efficiency. It becomes lethal when the temperature falls below 31°C or rises above 43°C. This is shown in Fig. 29.2.



**Fig.29.2:** Affect of the variation of core temperature on a human being

### 29.4: Heat balance equation for a human being:

The temperature of human body depends upon the energy balance between itself and the surrounding thermal environment. Taking the human body as the control volume, one can write the thermal energy (heat) balance equation for the human body as:

$$Q_{gen} = Q_{sk} + Q_{res} + Q_{st} \quad (29.1)$$

where  $Q_{gen}$  = Rate at which heat is generated inside the body  
 $Q_{sk}$  = Total heat transfer rate from the skin



$Q_{res}$  = Heat transfer rate due to respiration, and  
 $Q_{st}$  = Rate at which heat is stored inside the body

The heat generation rate  $Q_{gen}$  is given by:

$$Q_{gen} = M(1 - \eta) \approx M \quad (29.2)$$

where  $M$  = Metabolic rate, and

$\eta$  = Thermal efficiency  $\approx 0$  for most of the activities

The metabolic rate depends on the activity. It is normally measured in the unit “**met**”. A met is defined as the metabolic rate per unit area of a sedentary person and is found to be equal to about **58.2 W/m<sup>2</sup>**. This is also known as “basal metabolic rate”. Table 29.1 shows typical metabolic rates for different activities:

### Typical metabolic rates

Activity	Specifications	Metabolic rate
Resting	Sleeping	0.7 met
	Reclining	0.8 met
	Seated, quite	1.0 met
	Standing, relaxed	1.2 met
Walking	0.89 m/s	2.0 met
	1.79 m/s	3.8 met
Office activity	Typing	1.1 met
Driving	Car	1.0 to 2.0 met
	Heavy vehicles	3.2 met
Domestic activities	Cooking	1.6 to 2.0 met
	Washing dishes	1.6 met
	House cleaning	2.0 to 3.4 met
Dancing	-	2.4 to 4.4 met
Teaching	-	1.6 met
Games and sports	Tennis, singles	3.6 to 4.0 met
	Gymnastics	4.0 met
	Basket ball	5.0 to 7.6 met
	Wrestling	7.0 to 8.7 met

Studies show that the metabolic rate can be correlated to the rate of respiratory oxygen consumption and carbon dioxide production. Based on this empirical equations have been developed which relate metabolic rate to  $O_2$  consumption and  $CO_2$  production.

Since the metabolic rate is specified per unit area of the human body (naked body), it is essential to estimate this area to calculate the total metabolic rate. Even though the metabolic rate and heat dissipation are not uniform throughout the body, for calculation purposes they are assumed to be uniform.

The human body is considered to be a cylinder with uniform heat generation and dissipation. The surface area over which the heat dissipation takes place is given by an empirical equation, called as **Du Bois Equation**. This equation expresses the surface area as a function of the mass and height of the human being. It is given by:

$$A_{Du} = 0.202 m^{0.425} h^{0.725} \quad (29.3)$$

where  $A_{Du}$  = Surface area of the naked body,  $m^2$   
 $m$  = Mass of the human being, kg  
 $h$  = Height of the human being, m

Since the area given by Du Bois equation refers to a naked body, a correction factor must be applied to take the clothing into account. This correction factor, defined as the “**ratio of surface area with clothes to surface area without clothes**” has been determined for different types of clothing. These values are available in ASHRAE handbooks. Thus from the metabolic rate and the surface area, one can calculate the amount of heat generation,  $Q_{gen}$ .

The total heat transfer rate from the skin  $Q_{sk}$  is given by:

$$Q_{sk} = \pm Q_{conv} \pm Q_{rad} + Q_{evp} \quad (29.4)$$

where  $Q_{conv}$  = Heat transfer rate due to convection (sensible heat)  
 $Q_{rad}$  = Heat transfer rate due to radiation (sensible heat), and  
 $Q_{evp}$  = Heat transfer rate due to evaporation (latent heat)

The convective and radiative heat transfers can be positive or negative, i.e., a body may lose or gain heat by convection and radiation, while the evaporation heat transfer is always positive, i.e., a body always loses heat by evaporation. Using the principles of heat and mass transfer, expressions have been derived for estimating the convective, radiative and evaporative heat transfer rates from a human body. As it can be expected, these heat transfer rates depend on several factors that influence each of the heat transfer mechanism.

According to Belding and Hatch, the convective, radiative and evaporative heat transfer rates from the naked body of an average adult,  $Q_c$ ,  $Q_r$  and  $Q_e$ , respectively, are given by:

$$\begin{aligned} Q_c &= 14.8 V^{0.5} (t_b - t) \\ Q_r &= 11.603 (t_b - t_s) \\ Q_e &= 181.76 V^{0.4} (p_{s,b} - p_v) \end{aligned} \quad (29.5)$$

In the above equation all the heat transfer rates are in watts, temperatures are in °C and velocity is in m/s;  $p_{s,b}$  and  $p_v$  are the saturated pressure of water vapour at surface temperature of the body and partial pressure of water vapour in air, respectively, in kPa. From the above equations it is clear that the convective heat transfer from the skin can be increased either by increasing the surrounding air velocity ( $V$ ) and/or by reducing the surrounding air DBT ( $t$ ). The radiative heat transfer rate can be increased by reducing the temperature of the surrounding surfaces with which the body exchanges radiation. The evaporative heat transfer rate can be increased by increasing the surrounding air velocity and/or by reducing the moisture content of surrounding air.

The heat transfer rate due to respiration  $Q_{res}$  is given by:

$$Q_{res} = C_{res} + E_{res} \quad (29.5)$$

where  $C_{res}$  = Dry heat loss from respiration (sensible, positive or negative)  
 $E_{res}$  = Evaporative heat loss from respiration (latent, always positive)

The air inspired by a human being is at ambient conditions, while air expired is considered to be saturated and at a temperature equal to the core temperature. Significant heat transfer can occur due to respiration. Correlations have been obtained for dry and evaporative heat losses due to respiration in terms of metabolic rate, ambient conditions etc.

For comfort, the rate of heat stored in the body  $Q_{st}$  should be zero, i.e.,

$$Q_{st} = 0 \text{ at neutral condition} \quad (29.6)$$

However, it is observed that a human body is rarely at steady state, as a result the rate of heat stored in the body is non-zero most of the time. Depending upon the surroundings and factors such as activity level etc., the heat stored is either positive or negative. However, the body cannot sustain long periods of heat storage with a consequent change in body temperatures as discussed before.

Since the body temperature depends on the heat balance, which in turn depends on the conditions in the surroundings, it is important that the surrounding conditions should be such that the body is able to maintain the thermal equilibrium with minimum regulatory effort. All living beings have **in-built body regulatory processes against cold and heat**, which to some extent maintains the body temperatures when the external conditions are not favorable. For example, human beings consist of a thermoregulatory system, which tries to maintain the body temperature by initiating certain body regulatory processes against cold and heat.

When the **environment is colder** than the neutral zone, then body loses more heat than is generated. Then the regulatory processes occur in the following order.

1. Zone of vaso-motor regulation against cold (vaso-constriction): Blood vessels adjacent to the skin constrict, reducing flow of blood and transport of heat to the immediate outer surface. The outer skin tissues act as insulators.

2. Zone of metabolic regulation: If environmental temperature drops further, then vaso-motor regulation does not provide enough protection. Hence, through a spontaneous increase of activity and by shivering, body heat generation is increased to take care of the increased heat losses.

3. Zone of inevitable body cooling: If the environmental temperature drops further, then the body is not able to combat cooling of its tissues. Hence the body temperature drops, which could prove to be disastrous. This is called as zone of inevitable body cooling.

When the **environment is hotter** than the neutral zone, then body loses less heat than is generated. Then the regulatory processes occur in the following order.

1. Zone of vaso-motor regulation against heat (vaso-dilation): Here the blood vessels adjacent to the skin dilate, increasing the flow of blood and transport of heat to the immediate outer surface. The outer skin temperature increases providing a greater temperature for heat transfer by convection and radiation.

2. Zone of evaporative regulation: If environmental temperature increases further, the sweat glands become highly active drenching the body surface with perspiration. If the surrounding air humidity and air velocity permit, then increase in body temperature is prevented by increased evaporation from the skin.

3. Zone of inevitable body heating: If the environmental temperature increases further, then body temperature increases leading to the zone of inevitable body heating. The internal body temperature increases leading several ill effects such as heat exhaustion (with symptoms of fatigue, headache, dizziness, irritability etc.), heat cramps (resulting in loss of body salts due to increased perspiration) and finally heat stroke. Heat stroke could cause permanent damage to the brain or could even be lethal if the body temperature exceeds 43°C.

Thus it is seen that even though human body possesses a regulatory mechanism, beyond certain conditions it becomes ineffective. Hence it is essential to ensure that surrounding conditions are conducive for comfortable and safe living. The purpose of a comfort air conditioning system is to provide suitable conditions in the occupied space so that it is thermally comfortable to the occupants.

A sedentary person at neutral condition loses about 40 % of heat by evaporation, about 30 % by convection and 30 % by radiation. However, this proportion may change with other factors. For example, the heat loss by evaporation increases when the DBT of the environment increases and/or the activity level increases

## 29.5. Factors affecting thermal comfort:

Thermal comfort is affected by several factors. These are:

1. Physiological factors such as age, activity, sex and health. These factors influence the metabolic rate. It is observed that of these factors, the most important is activity. Other factors are found to have negligible effect on thermal comfort.

2. Insulating factor due to clothing. The type of clothing has strong influence on the rate of heat transfer from the human body. The unit for measuring the resistance offered by clothes is called as “clo”. 1 clo is equal to a resistance of about  $0.155 \text{ m}^2\cdot\text{K/W}$ . Typical clo values for different types of clothing have been estimated and are available in the form of tables. For example, a typical business suit has a clo value of 1.0, while a pair of shorts has a clo value of about 0.05.

3. Environmental factors. Important factors are the dry bulb temperature, relative humidity, air motion and surrounding surface temperature. Of these the dry bulb temperature affects heat transfer by convection and evaporation, the relative humidity affects heat loss by evaporation, air velocity influences both convective and evaporative heat transfer and the surrounding surface temperature affects the radiative heat transfer.

Apart from the above, other factors such as drafts, asymmetrical cooling or heating, cold or hot floors etc. also affect the thermal comfort. The objective of a comfort air conditioning system is to control the environmental factors so that comfort conditions prevail in the occupied space. It has no control on the physiological and insulating factors. However, wearing suitable clothing may help in reducing the cost of the air conditioning system.

## 29.6. Indices for thermal comfort:

It is seen that important factors which affect thermal comfort are the activity, clothing, air DBT, RH, air velocity and surrounding temperature. It should be noted that since so many factors are involved, many combinations of the above conditions provide comfort. Hence to evaluate the effectiveness of the conditioned space, several comfort indices have been suggested. These indices can be divided into direct and derived indices. The direct indices are the dry bulb temperature, humidity ratio, air velocity and the mean radiant temperature ( $T_{\text{mrt}}$ ).

The mean radiant temperature  $T_{mrt}$  affects the radiative heat transfer and is defined (in K) as:

$$T_{mrt}^4 = T_g^4 + CV^{1/2}(T_g - T_a) \quad (29.7)$$

where:

$T_g$  = Globe temperature measured at steady state by a thermocouple placed at the center of a black painted, hollow cylinder (6" dia) kept in the conditioned space, K. The reading of thermocouple results from a balance of convective and radiative heat exchanges between the surroundings and the globe

$T_a$  = Ambient DBT, K

$V$  = Air velocity in m/s, and

$C$  = A constant,  $0.247 \times 10^9$

The derived indices combine two or more direct indices into a single factor. Important derived indices are the effective temperature, operative temperature, heat stress index, Predicted Mean Vote (PMV), Percent of People Dissatisfied (PPD) etc.

**Effective temperature (ET):** This factor combines the effects of dry bulb temperature and air humidity into a single factor. It is defined as the temperature of the environment at 50% RH which results in the same total loss from the skin as in the actual environment. Since this value depends on other factors such as activity, clothing, air velocity and  $T_{mrt}$ , a Standard Effective Temperature (SET) is defined for the following conditions:

<b>Clothing</b>	=	<b>0.6 clo</b>
<b>Activity</b>	=	<b>1.0 met</b>
<b>Air velocity</b>	=	<b>0.1 m/s</b>
<b><math>T_{mrt}</math></b>	=	<b>DBT (in K)</b>

**Operative temperature ( $T_{op}$ ):** This factor is a weighted average of air DBT and  $T_{mrt}$  into a single factor. It is given by:

$$T_{op} = \frac{h_r T_{mrt} + h_c T_{amb}}{h_r + h_c} \approx \frac{T_{mrt} + T_{amb}}{2} \quad (29.8)$$

where  $h_r$  and  $h_c$  are the radiative and convective heat transfer coefficients and  $T_{amb}$  is the DBT of air.

ASHRAE has defined a comfort chart based on the effective and operative temperatures. Figure 29.3 shows the ASHRAE comfort chart with comfort zones for summer and winter conditions. It can be seen from the chart that the comfort zones are bounded by effective temperature lines, a constant RH line of 60% and

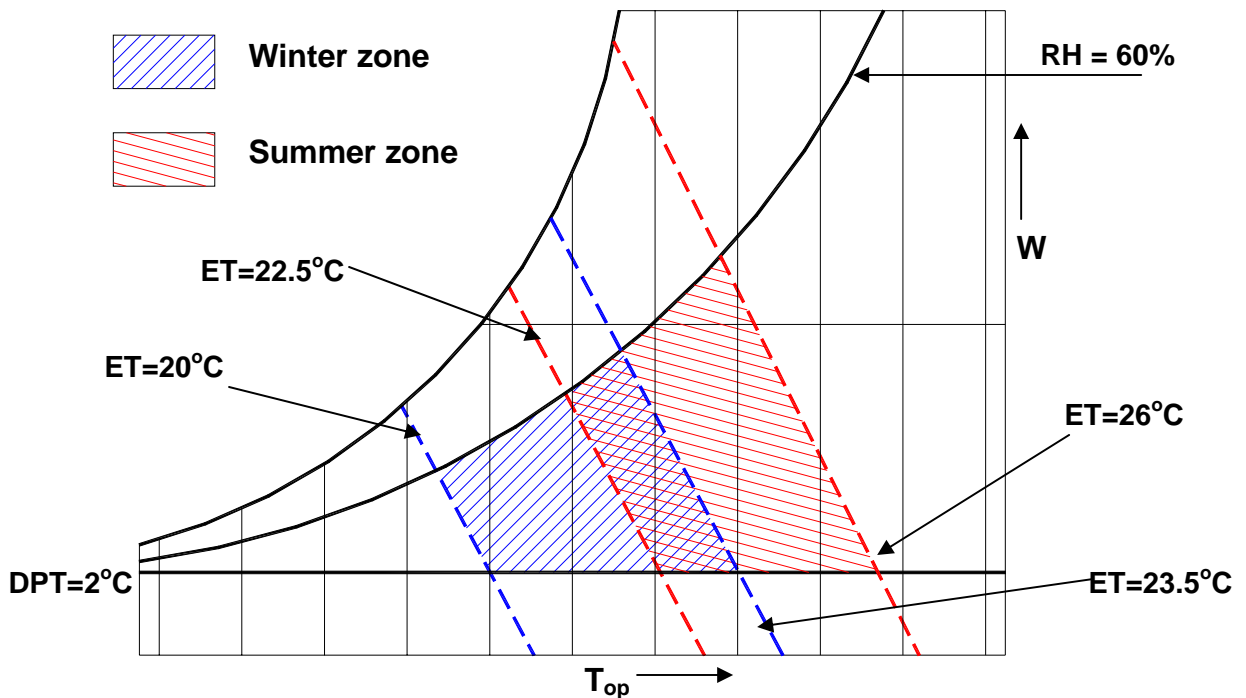
dew point temperature of 2°C. The upper and lower limits of humidity (i.e. 60 % RH and 2°C DPT, respectively) are based on the moisture content related considerations of dry skin, eye irritation, respiratory health and microbial growth. The comfort chart is based on statistical sampling of a large number of occupants with activity levels less than 1.2 met. On the chart, the region where summer and winter comfort zones overlap, people in winter clothing feel slightly warm and people in summer clothing feel slightly cool. Based on the chart ASHARE makes the following recommendations:

**Inside design conditions for Winter:**

- $T_{op}$  between 20.0 to 23.5°C at a RH of 60%**
- $T_{op}$  between 20.5 to 24.5°C at a DPT of 2°C**

**Inside design conditions for Summer:**

- $T_{op}$  between 22.5 to 26.0°C at a RH of 60%**
- $T_{op}$  between 23.5 to 27.0°C at a DPT of 2°C**



**Fig.29.3:** ASHRAE comfort chart for a sedentary person (activity ≈ 1.2 met)

Table 29.2 shows the recommended comfort conditions for different seasons and clothing suitable at 50 % RH, air velocity of 0.15 m/s and an activity level of  $\leq 1.2$  met.

Season	Clothing	$I_{cl}$	$T_{op,opt}$	$T_{op}$ range for 90% acceptance
Winter	Heavy slacks, long sleeve shirt and sweater	0.9 clo	22°C	20 to 23.5 °C
Summer	Light slacks and short sleeve shirt	0.5 clo	24.5°C	23 to 26°C
	Minimal (shorts)	0.05 clo	27°C	26 to 29 °C

**Table 29.2:** Optimum and recommended operative temperatures for comfort

The above values may be considered as recommended inside design conditions for comfort air conditioning. It will be shown later that the **cost of air conditioning (initial plus running) increases as the required inside temperature increases in case of winter and as the required inside condition decreases in case of summer**. Hence, air conditioning systems should be operated at as low a temperature as acceptable in winter and as high a temperature as acceptable in summer. Use of suitable clothing and maintaining suitable air velocities in the conditioned space can lead to reduced cost of air conditioning. For example, in summer the clothing should be minimal at a socially acceptable level, so that the occupied space can be maintained at higher temperatures. Similarly, by increasing air velocity without causing draft, one can maintain the occupied space at a higher temperature in summer. Similarly, the inside temperatures can be higher for places closer to the equator (**1°C rise in ET is allowed for each 5° reduction in latitude**). Of course, the above recommendations are for normal activities. The required conditions change if the activity levels are different. For example, when the activity level is high (e.g. in gymnasium), then the required indoor temperatures will be lower. These special considerations must be kept in mind while fixing the inside design conditions. Prof. P.O. Fanger of Denmark has carried out pioneering and detailed studies on thermal comfort and suggested comfort conditions for a wide variety of situations.

### 29.6.1. Predicted Mean Vote (PMV) and Percent People Dissatisfied (PPD):

Based on the studies of Fanger and subsequent sampling studies, ASHRAE has defined a thermal sensation scale, which considers the air temperature, humidity, sex of the occupants and length of exposure. The scale is based on empirical equations relating the above comfort factors. The scale varies



from +3 (**hot**) to -3 (**cold**) with 0 being the neutral condition. Then a Predicted Mean Vote (PMV) that predicts the mean response of a large number of occupants is defined based on the thermal sensation scale.

The PMV is defined by Fanger as:

$$\mathbf{PMV = [0.303 \exp(-0.036M) + 0.028]L} \quad (29.9)$$

where M is the metabolic rate and L is the thermal load on the body that is the difference between the internal heat generation and heat loss to the actual environment of a person experiencing thermal comfort. The thermal load has to be obtained by solving the heat balance equation for the human body.

Fanger related the PMV to Percent of People Dissatisfied (PPD) by the following equation:

$$\mathbf{PPD = 100 - 95 \exp[-(0.03353 \mathbf{PMV}^4 + 0.2179 \mathbf{PMV}^2)]} \quad (29.10)$$

where dissatisfied refers to anybody not voting for -1, 0 or +1. It can be seen from the above equation that even when the PMV is zero (i.e., no thermal load on body) 5 % of the people are dissatisfied! When PMV is within  $\pm 0.5$ , then PPD is less than 10 %.

Of late, several studies have been carried out on adaptive thermal comfort. These studies show that human beings adapt to their natural surroundings so as to feel thermally comfortable. The adaptation consists of changing their clothing, activity level and schedule, dietary habits etc. according to the surrounding conditions. Due to this human tendency, it is observed that human beings feel comfortable that are higher or lower than those suggested by the heat balance equation as outlined by Fanger. It is observed that there is correlation between the outside temperatures and the required inside temperatures at which human beings feel comfortable, or at least do not feel uncomfortable. For example, a study by Humphrey on adaptive thermal comfort in tropical countries suggests the following correlation for comfort temperature in free-running (non-air conditioned) buildings:

$$\mathbf{T_c = 0.534T_o + 12.9} \quad (29.11)$$

Where  $T_o$  and  $T_c$  are the outdoor and indoor comfort temperature in  $^{\circ}\text{C}$ , respectively. According to the above correlation, higher the outdoor temperature, higher can be the indoor temperature. This is very important from energy conservation point-of-view as air conditioning systems are very energy intensive, and the load on an air conditioning plant can be reduced by maintaining the indoor temperatures at as high a value as is allowed from thermal comfort point-of-view.

## 29.7. Selection of outside design conditions:

The ambient temperature and moisture content vary from hour-to-hour and from day-to-day and from place-to-place. For example, in summer the ambient temperature increases from sunrise, reaches a maximum in the afternoon and again decreases towards the evening. On a given day, the relative humidity also varies with temperature and generally reaches a minimum value when the ambient temperature is maximum. For most of the major locations of the world, meteorological data is available in the form of mean daily or monthly maximum and minimum temperatures and corresponding relative humidity or wet bulb temperature. As mentioned before, to estimate the required cooling capacity of an air conditioning plant, it is essential to fix the outside design conditions in addition to the inside conditions. It is obvious that the selected design conditions may prevail only for a short a duration, and most of the time the actual outside conditions will be different from the design values. As a result, for most of the time the plant will be running at off-design conditions.

The design outside conditions also depend on the following factors:

- a) Type of the structure, i.e., whether it is of heavy construction, medium or light
- b) Insulation characteristics of the building
- c) Area of glass or other transparent surfaces
- d) Type of usage
- e) Nature of occupancy
- f) Daily range (difference between maximum and minimum temperatures in a given day)

### 29.7.1. Outdoor design conditions for summer:

Selection of maximum dry and wet bulb temperatures at a particular location leads to excessively large cooling capacities as the maximum temperature generally persists for only a few hours in a year. Hence it is recommended that the outdoor design conditions for summer be chosen based on the values of dry bulb and mean coincident wet bulb temperature that is equaled or exceeded 0.4, 1.0 or 2.0 % of total hours in an year. These values for major locations in the world are available in data books, such as AHRAE handbooks. Whether to choose the 0.4 % value or 1.0 % value or 2.0 % value depends on specific requirements. In the absence of any special requirements, the 1.0% or 2% value may be considered for summer outdoor design conditions.

### 29.7.2. Outdoor design conditions for winter:

Similar to summer, it is not economical to design a winter air conditioning for the worst condition on record as this would give rise to very high heating capacities. Hence it is recommended that the outdoor design conditions for winter be chosen based on the values of **dry bulb temperature** that is **equaled or exceeded 99.6 or 99.0 % of total hours in an year**. Similar to summer design conditions, these values for major locations in the world are available in data books, such as AHRAE handbooks. Generally the 99.0% value is adequate, but if the building is made of light-weight materials, poorly insulated or has considerable glass or space temperature is critical, then the 99.6% value is recommended.

Table 29.3 shows the ASHRAE recommended summer design conditions for major Indian cities. In the table DB stands for the design DBT and MWB stands for mean coincident WBT.

City	0.4% value		1.0% value		2.0% value		Daily range
	DB	MWB	DB	MWB	DB	MWB	
Ahmadabad	42.2°C	23.3°C	41.1°C	23.3°C	39.4°C	23.9°C	12.7°C
Bangalore	34.4°C	19.4°C	33.3°C	19.4°C	32.8°C	19.4°C	10.7°C
Bombay	35.0°C	22.8°C	33.9°C	23.3°C	33.3°C	23.9°C	5.2°C
Calcutta	37.2°C	25.6°C	36.1°C	26.1°C	35.0°C	26.1°C	10.0°C
Hyderabad	40.6°C	21.7°C	39.4°C	21.7°C	39.4°C	21.7°C	10.5°C
Jaipur	42.2°C	20.6°C	40.6°C	20.6°C	39.4°C	20.6°C	12.4°C
Madras	38.3°C	25.0°C	37.2°C	25.0°C	36.1°C	25.0°C	8.1°C
Nagpur	43.3°C	21.7°C	42.2°C	21.7°C	41.1°C	21.7°C	12.7°C
New Delhi	41.7°C	22.2°C	40.6°C	22.2°C	39.4°C	22.8°C	12.0°C
Poona	37.8°C	19.4°C	37.2°C	19.4°C	36.1°C	19.4°C	16.1°C
Trivendrum	33.3°C	25.6°C	32.8°C	25.6°C	32.2°C	25.6°C	6.5°C

**Table 29.3:** Design summer outside conditions for some Indian cities (ASHRAE)

## Questions and answers:

1. Which of the following statements are TRUE?

- a) The metabolic rate depends mainly on age of the human being
- b) The metabolic rate depends mainly on the activity level of the human being
- c) The metabolic rate depends mainly on the sex of the human being
- d) All of the above

**Ans.: b)**

2. Which of the following statements are TRUE?

- a) To maintain thermal comfort, the DBT of air should be increased as its moisture content increases
- b) To maintain thermal comfort, the DBT of air should be decreased as air velocity increases
- c) To maintain thermal comfort, the DBT of air should be increased as the temperature of the surrounding surfaces decrease
- d) All of the above

**Ans.: c)**

3. Which of the following statements are TRUE?

- a) Surrounding air velocity affects convective heat transfer from the body only
- b) Surrounding air velocity affects evaporative heat transfer from the body only
- c) Surrounding air velocity affects both convective and evaporative heat transfers from the body
- d) Moisture content of the air affects both convective and evaporative heat transfers from the body

**Ans.: c)**

4. Which of the following statements are TRUE?

- a) As the amount of clothing increases, the surrounding DBT should be increased to maintain thermal comfort
- b) As the amount of clothing increases, the surrounding DBT should be decreased to maintain thermal comfort
- c) As the activity level increases, DBT of air should be increased to maintain thermal comfort
- d) As the activity level increases, DBT of air should be decreased to maintain thermal comfort

**Ans.: b) and d)**

5. Which of the following statements are TRUE?

- a) Effective temperature combines the affects of dry bulb temperature and air velocity into a single index
- b) Effective temperature combines the affects of dry bulb temperature and wet bulb temperature into a single index
- c) Mean radiant temperature combines the affects of dry bulb temperature and surrounding surface temperature into a single index
- d) Operative temperature combines the affects of dry bulb temperature and mean radiant temperature into a single index

**Ans.: b) and d)**

6. From ASHRAE comfort chart it is observed that:

- a) Lower dry bulb temperatures and higher moisture content are recommended for winter
- b) Lower dry bulb temperatures and lower moisture content are recommended for winter
- c) Lower dry bulb temperatures and higher moisture content are recommended for summer
- d) Higher dry bulb temperatures and higher moisture content are recommended for summer

**Ans.: b) and d)**

7. Which of the following statements are TRUE?

- a) For the same metabolic rate, as the thermal load on human body increases, the PMV value increases
- b) For the same metabolic rate, as the thermal load on human body increases, the PMV value decreases
- c) As the absolute value of PMV increases, the percent of people dissatisfied (PPD) increases
- d) As the absolute value of PMV increases, the percent of people dissatisfied (PPD) decreases

**Ans.: a) and c)**

8. Which of the following statements are TRUE?

- a) When a human body is at neutral equilibrium, the PMV value is 1.0
- b) When a human body is at neutral equilibrium, the PMV value is 0.0
- c) When a human body is at neutral equilibrium, the PPD value is 0.0
- d) When a human body is at neutral equilibrium, the PPD value is 5.0

**Ans.: b) and d)**

9. Which of the following statements are TRUE?

- a) The air conditioning load on a building increases, if 0.4% design value is used for outside conditions instead of 1.0% value for summer
- b) The air conditioning load on a building decreases, if 0.4% design value is used for outside conditions instead of 1.0% value for summer
- c) For winter air conditioning, a conservative approach is to select 99.6% value for the outside design conditions instead of 99% value
- d) For winter air conditioning, a conservative approach is to select 99% value for the outside design conditions instead of 99.6% value

**Ans.: a) and c)**

10. A 1.8 meter tall human being with a body mass of 60 kg performs light work (activity = 1.2 met) in an indoor environment. The indoor conditions are: DBT of 30°C, mean radiant temperature of 32°C, air velocity of 0.2 m/s. Assuming an average surface temperature of 34°C for the surface of the human being and light clothing, find the amount of evaporative heat transfer required so that the human being is at neutral equilibrium.

**Ans.:** Using Du Bois equation, the surface area of the human being  $A_s$  is:

$$A_{Du} = 0.202 m^{0.425} h^{0.725} = 0.202 \times 60^{0.425} \times 1.8^{0.725} = 1.7625 m^2$$

Hence the total heat generation rate from the body,  $Q_g$  is:

$$Q_g = A_s \times (\text{Activity level in met}) \times 58.2 = 1.7625 \times 1.2 \times 58.2 = 123.1 W$$

Using Belding & Hatch equations, the convective and radiative heat losses from the surface of the body are found as:

$$Q_c = 14.8 V^{0.5} (t_b - t) = 14.8 \times 0.2^{0.5} (34 - 30) = 26.48 W$$
$$Q_r = 11.603 (t_b - t_s) = 11.603 (34 - 32) = 23.2 W$$

For neutral equilibrium,

$$Q_g = Q_c + Q_r + Q_e \Rightarrow Q_e = Q_g - (Q_c + Q_r)$$

Substituting the values of  $Q_g$ ,  $Q_c$  and  $Q_r$  in the above expression, we find that the required amount of evaporative heat transfer  $Q_e$  is equal to:

$$Q_e = 123.1 - (26.48 + 23.2) = 73.42 W \quad (\text{Ans.})$$

# Lesson

## 30

# Psychrometry Of Air Conditioning Systems

## The specific objectives of this lecture are to:

1. Purpose of psychrometric calculations (*Section 30.1*)
2. Analysis of a simple, summer air conditioning system with 100% re-circulated air (*Section 30.2.1*)
3. Analysis of a summer air conditioning system with outdoor air for ventilation and with zero by-pass factor (*Section 30.2.2*)
4. Analysis of a simple, summer air conditioning system with outdoor air for ventilation and with non-zero by-pass factor (*Section 30.2.2*)
5. Analysis of a summer air conditioning system with re-heat for high latent cooling load applications (*Section 30.2.3*)
6. Selection guidelines for supply air conditions (*Section 30.3*)

At the end of the lesson, the student should be able to:

1. Estimate the load on the cooling coil and fix the supply conditions for various summer conditioning systems, namely:
  - a) Systems with 100% re-circulation
  - b) Systems with outdoor air for ventilation with zero by-pass factor
  - c) Systems with outdoor air for ventilation with non-zero by-pass factor
  - d) Systems with reheat for high latent cooling load applications

### 30.1. Introduction:

Generally from the building specifications, inside and outside design conditions; the latent and sensible cooling or heating loads on a building can be estimated. Normally, depending on the ventilation requirements of the building, the required outdoor air (fresh air) is specified. The topic of load estimation will be discussed in a later chapter. From known loads on the building and design inside and outside conditions, psychrometric calculations are performed to find:

1. Supply air conditions (air flow rate, DBT, humidity ratio & enthalpy)
2. Coil specifications (Latent and sensible loads on coil, coil ADP & BPF)

In this chapter fixing of supply air conditions and coil specifications for summer air conditioning systems are discussed. Since the procedure is similar for winter air conditioning system, the winter air conditioning systems are not discussed here.



## 30.2. Summer air conditioning systems:

### 30.2.1. Simple system with 100 % re-circulated air:

In this simple system, there is no outside air and the same air is recirculated as shown in Fig.30.1. Figure 30.2 also shows the process on a psychrometric chart. It can be seen that cold and dry air is supplied to the room and the air that leaves the condition space is assumed to be at the same conditions as that of the conditioned space. The supply air condition should be such that as it flows through the conditioned space it can counteract the sensible and latent heat transfers taking place from the outside to the conditioned space, so that the space can be maintained at required low temperature and humidity. Assuming no heat gains in the supply and return ducts and no energy addition due to fans, and applying energy balance across the room; the Room Sensible Cooling load ( $Q_{s,r}$ ), Room Latent Cooling Load ( $Q_{l,r}$ ) and Room Total Cooling load ( $Q_{t,r}$ ) are given by:

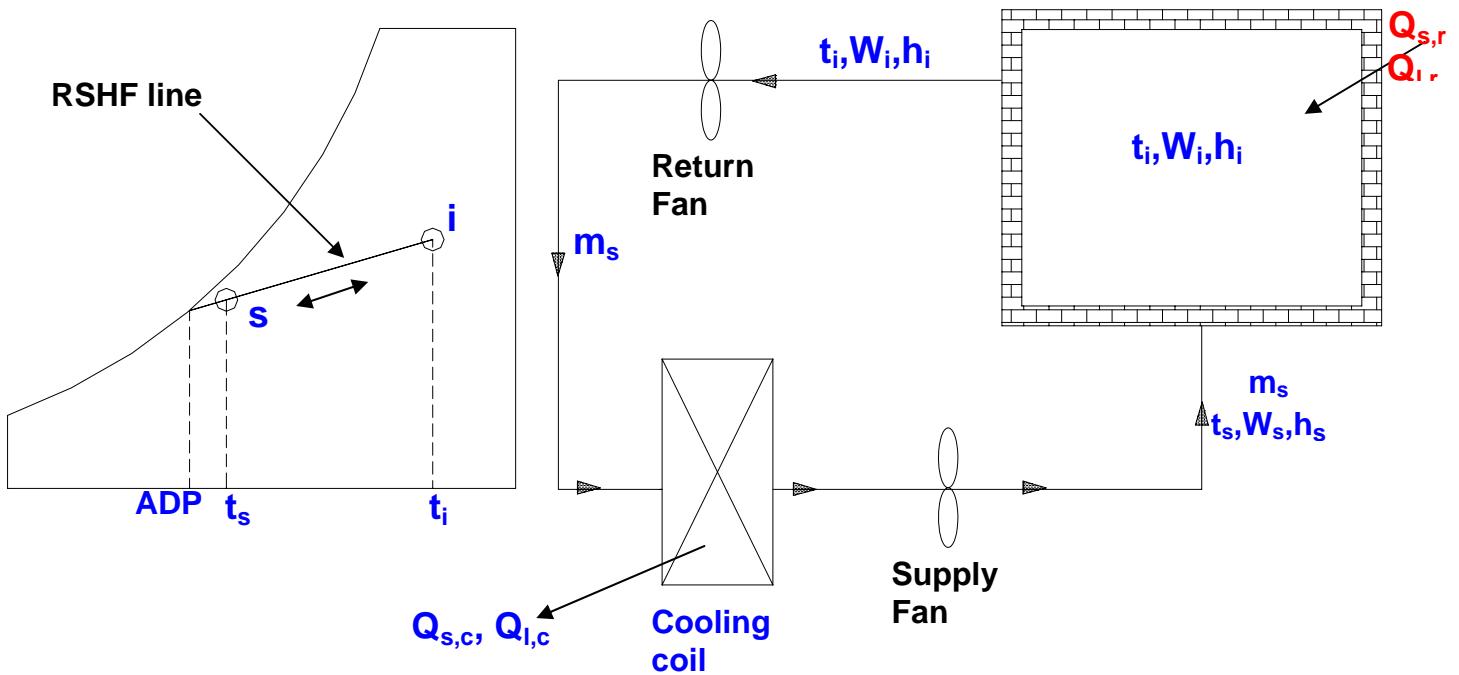
$$Q_{s,r} = m_s C_{pm} (t_i - t_s) \quad (30.1)$$

$$Q_{l,r} = m_s h_{fg} (W_i - W_s) \quad (30.2)$$

$$Q_{t,r} = Q_{s,r} + Q_{l,r} = m_s (h_i - h_s) \quad (30.3)$$

From cooling load calculations, the sensible, latent and total cooling loads on the room are obtained. Hence one can find the Room Sensible Heat Factor (RSHF) from the equation:

$$RSHF = \frac{Q_{s,r}}{Q_{s,r} + Q_{l,r}} = \frac{Q_{s,r}}{Q_{t,r}} \quad (30.4)$$



**Fig.30.1:** A simple, 100% re-circulation type air conditioning system

From the RSFH value one can calculate the slope of the process undergone by the air as it flows through the conditioned space (process s-i) as:

$$\text{slope of process line } s-i, \tan \theta = \frac{1}{2451} \left( \frac{1 - \text{RSFH}}{\text{RSFH}} \right) \quad (30.5)$$

Since the condition i is known say, from thermal comfort criteria, knowing the slope, one can draw the process line s-i through i. The intersection of this line with the saturation curve gives the ADP of the cooling coil as shown in Fig.30.1. It should be noted that for the given room sensible and latent cooling loads, **the supply condition must always lie on this line so that it can extract the sensible and latent loads on the conditioned space in the required proportions.**

Since the case being considered is one of 100 % re-circulation, the process that the air undergoes as it flows through the cooling coil (i.e. process i-s) will be exactly opposite to the process undergone by air as it flows through the room (process s-i). Thus, the temperature and humidity ratio of air decrease as it flows through the cooling coil and temperature and humidity ratio increase as air flows through the conditioned space. Assuming no heat transfer due to the ducts and fans, **the sensible and latent heat transfer rates at the cooling coil are exactly equal to the sensible and latent heat transfer rates to the conditioned space; i.e.,**

$$Q_{s,r} = Q_{s,c} \text{ \& \ } Q_{l,r} = Q_{l,c} \quad (30.6)$$

### Fixing of supply condition:

The supply condition has to be fixed using Eqns.(30.1) to (30.3). However, since there are **4 unknowns** ( $m_s$ ,  $t_s$ ,  $W_s$  and  $h_s$ ) and **3 equations**, (Eqns.(30.1) to (30.3)), one parameter has to be fixed to find the other three unknown parameters from the three equations.

If the by-pass factor ( $X$ ) of the cooling coil is known, then, from room conditions, coil ADP and by-pass factor, the supply air temperature  $t_s$  is obtained using the definition of by-pass factor as:

$$X = \left( \frac{t_s - t_{ADP}}{t_i - t_{ADP}} \right) \Rightarrow t_s = t_{ADP} + X(t_i - t_{ADP}) \quad (30.7)$$

Once the supply temperature  $t_s$  is known, then the mass flow rate of supply air is obtained from Eqn.(30.1) as:

$$m_s = \frac{Q_{s,r}}{C_{pm}(t_i - t_s)} = \frac{Q_{s,r}}{C_{pm}(t_i - t_{ADP})(1 - X)} \quad (30.8)$$

From the mass flow rate of air and condition  $i$ , the supply air humidity ratio and enthalpy are obtained using Eqns.(30.2) and (30.3) as:

$$W_s = W_i - \frac{Q_{l,r}}{m_s h_{fg}} \quad (30.9)$$

$$h_s = h_i - \frac{Q_{t,r}}{m_s} \quad (30.10)$$

From Eqn.(30.8), it is clear that the required mass flow rate of supply air decreases as the by-pass factor  $X$  decreases. In the limiting case when the by-pass factor is zero, the **minimum amount of supply air flow rate required** is:

$$m_{s,min} = \frac{Q_{s,r}}{C_{pm}(t_i - t_{ADP})} \quad (30.11)$$

Thus with 100 % re-circulated air, the room ADP is equal to coil ADP and the load on the coil is equal to the load on the room.

### 30.2.2. System with outdoor air for ventilation:

In actual air conditioning systems, some amount of outdoor (fresh) air is added to take care of the ventilation requirements. Normally, the required outdoor air for ventilation purposes is known from the occupancy data and the type of the building (e.g. operation theatres require 100% outdoor air). Normally either the quantity of outdoor air required is specified in absolute values or it is specified as a fraction of the re-circulated air.



### Calculation of coil loads:

From energy balance across the cooling coil; the sensible, latent and total heat transfer rates,  $Q_{s,c}$ ,  $Q_{l,c}$  and  $Q_{t,c}$  at the cooling coil are given by:

$$\begin{aligned}Q_{s,c} &= m_s C_{pm} (t_m - t_s) \\Q_{l,c} &= m_s h_{fg} (W_m - W_s) \\Q_{t,c} &= Q_{s,c} + Q_{l,c} = m_s (h_m - h_s)\end{aligned}\quad (30.14)$$

Where 'm' refers to the mixing condition which is a result of mixing of the recirculated air with outdoor air. Applying mass and energy balance to the mixing process one can obtain the state of the mixed air from the equation:

$$\frac{m_o}{m_s} = \frac{W_m - W_i}{W_o - W_i} = \frac{h_m - h_i}{h_o - h_i} \approx \frac{t_m - t_i}{t_o - t_i}\quad (30.15)$$

Since  $(m_o/m_s) > 0$ , from the above equation it is clear that  $W_m > W_i$ ,  $h_m > h_i$  and  $t_m > t_i$ . This implies that  $m_s(h_m - h_s) > m_s(h_i - h_s)$ , or the **load on the cooling coil is greater than the load on the conditioned space**. This is of course due to the fact that during mixing, some amount of hot and humid air is added and the same amount of relative cool and dry air is exhausted ( $m_o = m_e$ ).

From Eqn.(30.1) to (30.3) and (30.14), the difference between the cooling load on the coil and cooling load on the conditioned space can be shown to be equal to:

$$\begin{aligned}Q_{s,c} - Q_{s,r} &= m_o C_{pm} (t_o - t_i) \\Q_{l,c} - Q_{l,r} &= m_o h_{fg} (W_o - W_i) \\Q_{t,c} - Q_{t,r} &= m_o (h_o - h_i)\end{aligned}\quad (30.16)$$

From the above equation it is clear that the difference between cooling coil and conditioned space increases as the amount of outdoor air ( $m_o$ ) increases and/or the outdoor air becomes hotter and more humid.

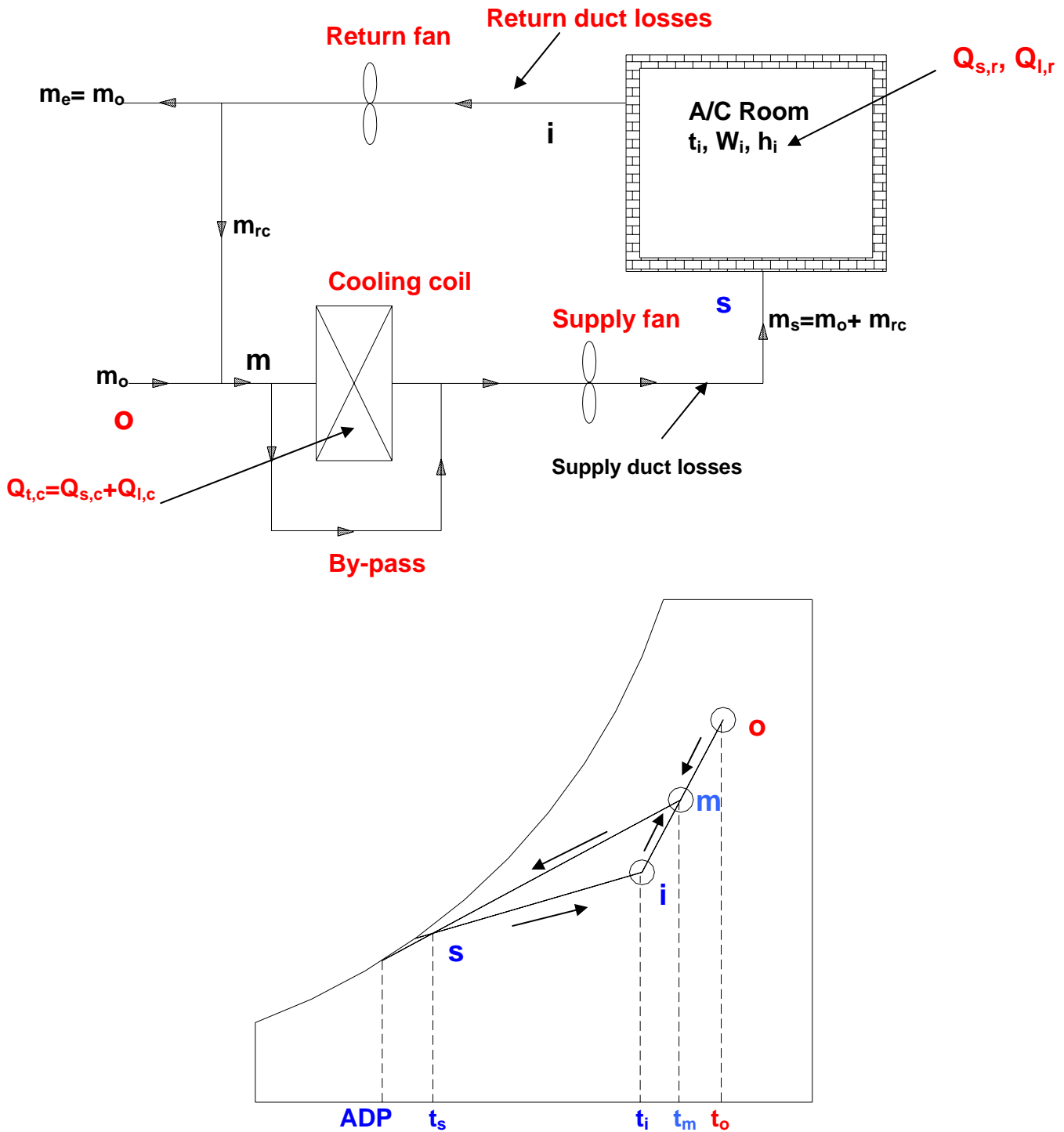
The line joining the mixed condition 'm' with the coil ADP is the process line undergone by the air as it flows through the cooling coil. The slope of this line depends on the Coil Sensible Heat Factor (CSHF) given by:

$$CSHF = \frac{Q_{s,c}}{Q_{s,c} + Q_{l,c}} = \frac{Q_{s,c}}{Q_{t,c}}\quad (30.17)$$

### Case ii: Coil by-pass factor, $X > 0$ :

For actual cooling coils, the by-pass factor will be greater than zero, as a result the air temperature at the exit of the cooling coil will be higher than the coil ADP. This is shown in Fig.30.3 along with the process on psychrometric chart. It can

be seen from the figure that when  $X > 0$ , the room ADP will be different from the coil ADP. The system shown in Fig.30.3 is adequate when the RSHF is high ( $> 0.75$ ).



**Fig.30.3:** A summer air conditioning system with outdoor air for ventilation and a non-zero by-pass factor

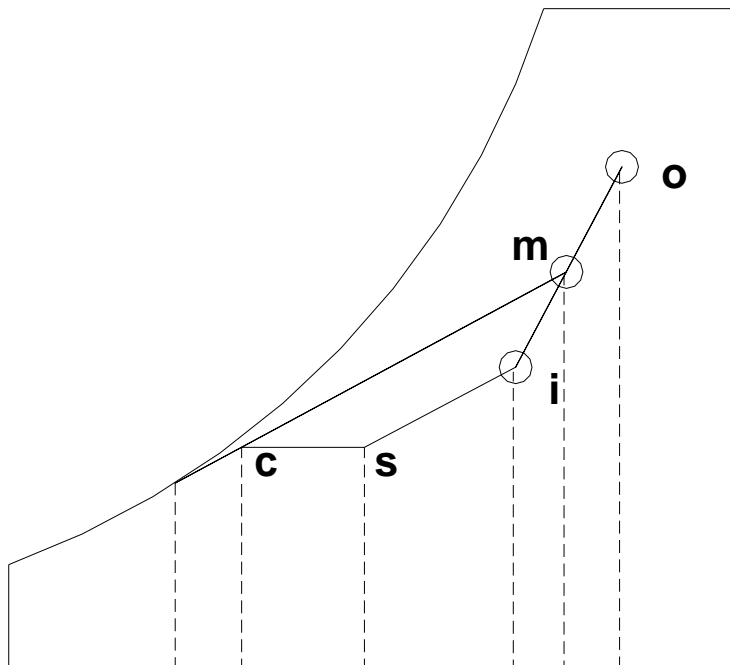
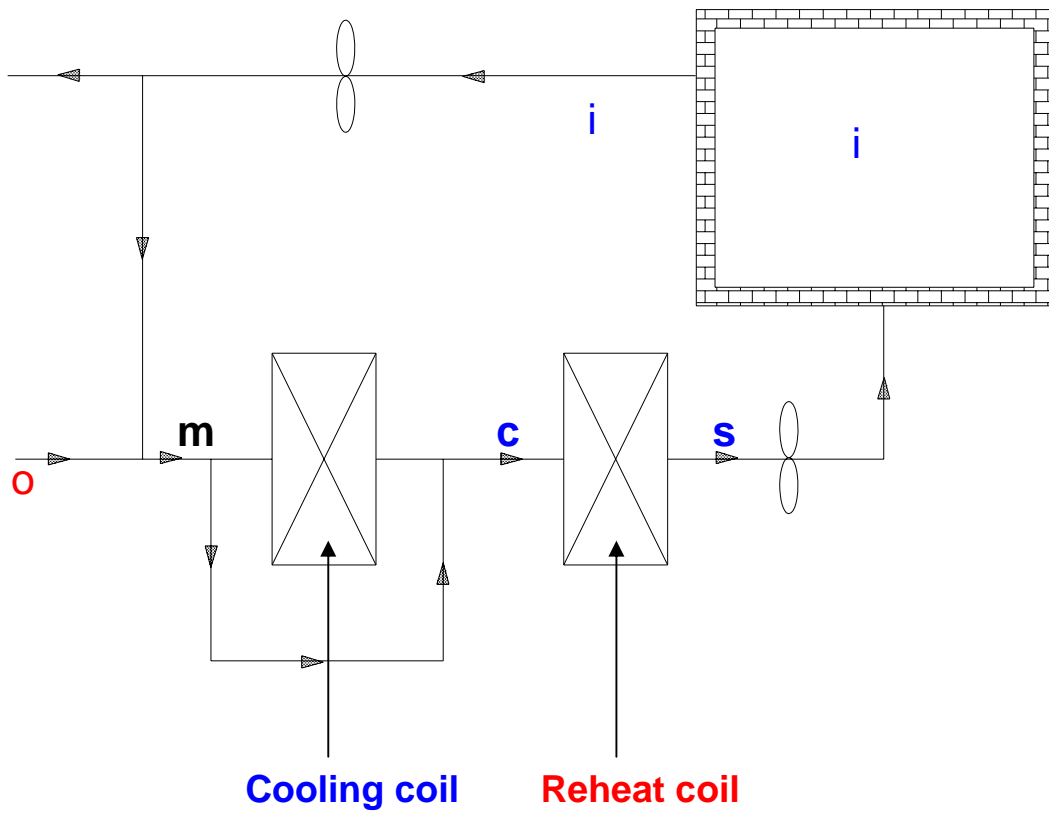
Normally in actual systems, either the supply temperature ( $t_s$ ) or the temperature rise of air as it flows through the conditioned space ( $t_i - t_s$ ) will be specified. Then the step-wise procedure for finding the supply air conditions and the coil loads are as follows:

- i. Since the supply temperature is specified one can calculate the required supply air flow rate and supply conditions using Eqns. (30.8) to (30.10).
- ii. Since conditions 'i', supply air temperature  $t_s$  and RSHF are known, one can draw the line i-s. The intersection of this line with the saturation curve gives the room ADP.
- iii. Condition of air after mixing (point 'm') is obtained from known values of  $m_s$  and  $m_o$  using Eqn.(30.15).
- iv. Now joining points 'm' and 's' gives the process line of air as it flows through the cooling coil. The intersection of this line with the saturation curve gives the coil ADP. It can be seen that the coil ADP is lower than the room ADP.
- v. The capacity of the cooling coil is obtained from Eqn.(30.14).
- vi. From points 'm', 's' and coil ADP, the by-pass factor of the cooling coil can be calculated.

If the coil ADP and coil by-pass factor are given instead of the supply air temperature, then a trial-and-error method has to be employed to obtain the supply air condition.

### **30.2.3. High latent cooling load applications (low RSHF):**

When the latent load on the building is high due either to high outside humidity or due to large ventilation requirements (e.g. hospitals) or due to high internal latent loads (e.g. presence of kitchen or laundry), then the simple system discussed above leads to very low coil ADP. A low coil ADP indicates operation of the refrigeration system at low evaporator temperatures. Operating the system at low evaporator temperatures decreases the COP of the refrigeration system leading to higher costs. Hence a reheat coil is sometimes used so that the cooling coil can be operated at relatively high ADP, and at the same time the high latent load can also be taken care of. Figure 30.4 shows an air conditioning system with reheat coil along with the psychrometric representation of the process. As shown in the figure, in a system with reheat coil, air is first cooled and dehumidified from point 'm' to point 'c' in the cooling coil and is then reheated sensibly to the required supply temperature  $t_s$  using the reheat coil. If the supply temperature is specified, then the mass flow rate and state of the supply air and condition of the air after mixing can be obtained using equations given above. Since the heating process in the reheat coil is sensible, the process line c-s will be horizontal. Thus if the coil ADP is known, then one can draw the coil condition line and the intersection of this line with the horizontal line drawn from supply state 's' gives the condition of the air at the exit of the cooling coil. From this condition, one can calculate the load on the cooling coil using the supply mass flow rate and state of air after mixing. The capacity of the reheat coil is then obtained from energy balance across it, i.e.,



**Fig.30.4:** A summer air conditioning system with reheat coil for high latent cooling load applications



### Advantages and disadvantages of reheat coil:

- a) Refrigeration system can be operated at reasonably high evaporator temperatures leading to high COP and low running cost.
- b) However, mass flow rate of supply air increases due to reduced temperature rise ( $t_i - t_s$ ) across the conditioned space
- c) Wasteful use of energy as air is first cooled to a lower temperature and then heated. Energy is required for both cooling as well as reheat coils. However, this can be partially offset by using waste heat such as heat rejected at the condenser for reheating of air.

Thus the actual benefit of reheat coil depends may vary from system.

### 30.3. Guidelines for selection of supply state and cooling coil:

- i. As much as possible the supply air quantity should be minimized so that smaller ducts and fans can be used leading savings in cost of space, material and power. However, the minimum amount should be sufficient to prevent the feeling of stagnation. If the required air flow rate through the cooling coil is insufficient, then it is possible to mix some amount of re-circulated air with this air so that amount of air supplied to the conditioned space increases. This merely increases the supply air flow rate, but does not affect sensible and cooling loads on the conditioned space. Generally, the temperature rise ( $t_i - t_s$ ) will be in the range of 8 to 15°C.
- ii. The cooling coil should have 2 to 6 rows for moderate climate and 6 to 8 rows in hot and humid climate. The by-pass factor of the coil varies from 0.05 to 0.2. The by-pass factor decreases as the number of rows increases and vice versa. The fin pitch and air velocity should be suitable.
- iii. If chilled water is used for cooling and dehumidification, then the coil ADP will be higher than about 4°C.

## Questions and answers:

1. State which of the following statements are TRUE?

- a) The purpose of psychrometric calculations is to fix the supply air conditions
- b) The purpose of psychrometric calculations is to find the load on the building
- c) In a 100% re-circulation system, the coil ADP is equal to room ADP
- d) In a 100% re-circulation system, the coil ADP is less than room ADP

**Ans.: a) and c)**

2. State which of the following statements are TRUE?

- a) In a 100% re-circulation system, the load on coil is equal to the load on building
- b) In a system with outdoor air for ventilation, the load on building is greater than the load on coil
- c) In a system with outdoor air for ventilation, the load on building is less than the load on coil
- d) In a system with outdoor air for ventilation, the Coil ADP is less than room ADP

**Ans.: a), c) and d)**

3. Which of the following statements are TRUE?

- a) Systems with reheat are used when the Room Sensible Heat Factor is low
- b) Systems with reheat are used when the Room Sensible Heat Factor is high
- c) When reheat coils are used, the required coil ADP can be increased
- d) When reheat coils are used, the required supply airflow rate increases

**Ans.: a), c) and d)**

4. A 100% outdoor summer air conditioning system has a room sensible heat load of 400 kW and a room latent heat load of 100 kW. The required inside conditions are 24°C and 50% RH, and the outdoor design conditions are 34°C and 40% RH. The air is supplied to the room at a dry bulb temperature of 14°C. Find a) the required mass flow rate of air b) moisture content of supply air, c) Sensible, latent heat loads on the coil, and d) The required cooling capacity of the coil, Coil Sensible Heat Factor and coil ADP if the by-pass factor of the coil is 0.2. Barometric pressure = 1 atm. Comment on the results.

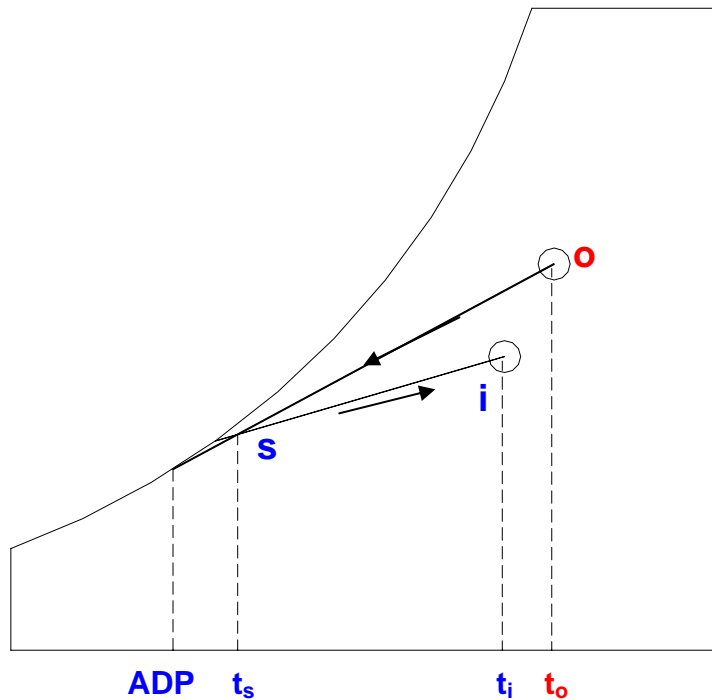
**Ans.:** The psychrometric process for this system is shown in Fig.30.5.

The psychrometric properties at inside and outside conditions are:

Inside conditions:  $t_i = 24^\circ\text{C}$ (DBT) and  $\text{RH}_i = 50\%$

From psychrometric chart or using psychrometric equations; the moisture content and enthalpy of inside air are:

$$W_i = 0.0093 \text{ kgw/kgda}, h_i = 47.66 \text{ kJ/kgda}$$



**Fig.30.5:** A summer air conditioning system with 100% outdoor air

outside conditions:  $t_i = 34^\circ\text{C}$  (DBT) and  $\text{RH}_i = 40\%$

From psychrometric chart or using psychrometric equations; the moisture content and enthalpy of inside air are:

$$W_o = 0.01335 \text{ kgw/kgda}, h_1 = 68.21 \text{ kJ/kgda}$$

a) From sensible energy balance equation for the room, we find the required mass flow rate of air as:

$$m_s = \frac{Q_{s,r}}{C_{pm}(t_i - t_s)} = \frac{400}{1.0216(24 - 14)} = 39.154 \text{ kg/s} \quad (\text{Ans.})$$

b) The moisture content of supply air is obtained from latent energy balance of the room as:

$$W_s = W_i - \frac{Q_{l,r}}{m_s h_{fg}} = 0.0093 - \frac{100}{39.154 \times 2501} = 0.0083 \text{ kgw/kgda} \quad (\text{Ans.})$$

c) From energy balance, the sensible and latent loads on the coil are obtained as:

$$Q_{s,c} = m_s C_{pm}(t_o - t_s) = 39.154 \times 1.0216 \times (34 - 14) = 800 \text{ kW}$$

$$Q_{l,c} = m_s h_{fg}(W_o - W_s) = 39.154 \times 2501 \times (0.01335 - 0.0083) = 494.5 \text{ kW} \quad (\text{Ans.})$$

d) The required cooling capacity of the coil is equal to the total load on the coil,  $Q_{t,c}$ :

$$Q_{t,c} = Q_{s,c} + Q_{l,c} = 800 + 494.5 = 1294.5 \text{ kW} \quad (\text{Ans.})$$

$$\text{Coil Sensible Heat Factor, CSHF} = Q_{s,c}/Q_{t,c} = 0.618 \quad (\text{Ans.})$$

Coil ADP is obtained by using the definition of by-pass factor (X) as:

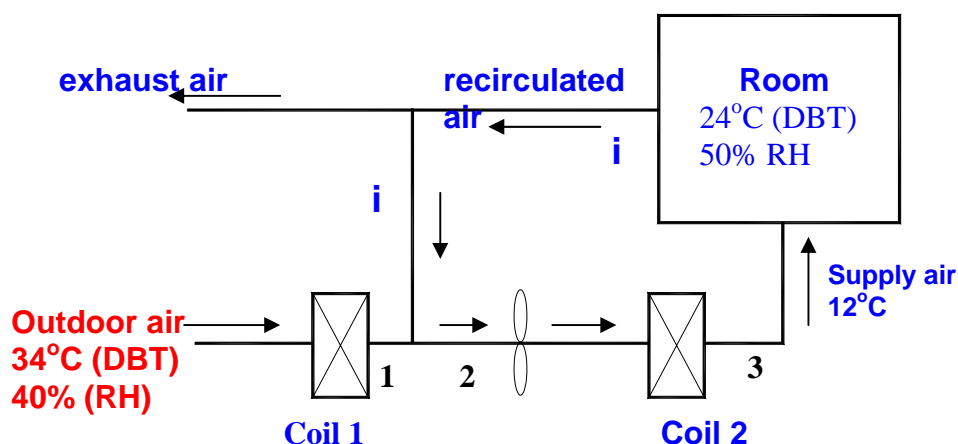
$$t_{ADP}(1 - X) = t_s - X.t_o$$

$$\Rightarrow t_{ADP} = (t_s - X.t_o)/(1-X) = (14 - 0.2 \times 34)/(1 - 0.2) = 9^\circ\text{C} \quad (\text{Ans.})$$

### Comments:

1. It is seen that with 100% outdoor air, the load on the coil (or required cooling capacity of the coil) is much higher compared to the cooling load on the building (Required coil capacity = 1294.5 kW whereas the total load on the room is 500 kW). Since 100% outdoor air is used, the relatively cold and dry indoor air is exhausted without re-circulation and the hot and humid air is conditioned using the coil coil. Thus the required cooling capacity is very high as the cooling coil has to cool and dehumidify outdoor air.
2. It is observed that the CSHF (0.618) is much smaller compared to the room SHF (0.8), hence, the coil ADP is much smaller than the room ADP.

5. A room is air conditioned by a system that maintains 25°C dry bulb and 50 % RH inside, when the outside conditions are 34°C dry bulb and 40% RH. The room sensible and latent heat gains are 60 kW and 12 kW respectively. As shown in the figure below, The outside fresh air first flows over a first cooler coil and is reduced to state 1 of 10°C dry bulb and a relative humidity of 85%. It is then mixed with re-circulated air, the mixture (state 2) being handled by a fan, passed over a second cooler coil and sensibly cooled to 12°C dry bulb (state 3). The air is then delivered to the room. If the outside fresh air is used for dealing with the whole of the room latent heat gain and if the effects of fan power and duct heat gains are ignored, find: a) mass flow rates of outside fresh air and supply air; b) DBT and enthalpy of the air handled by the fan (state 2); and c) required cooling capacity of first cooler coil and second sensible cooler coil.



**Ans.:** From psychrometric chart, the following properties are obtained:

Inside conditions:  $t_i = 24^\circ\text{C}(\text{DBT})$  and  $\text{RH}_i = 50\%$

$$W_i = 0.0093 \text{ kgw/kgda}, h_i = 47.66 \text{ kJ/kgda}$$

outside conditions:  $t_o = 34^\circ\text{C}$ (DBT) and  $\text{RH}_o = 40\%$

$$W_o = 0.01335 \text{ kgw/kgda}, h_i = 68.21 \text{ kJ/kgda}$$

At state 1:  $t_1 = 10^\circ\text{C}$ (DBT) and  $\text{RH}_1 = 85\%$

$$W_1 = 0.00647 \text{ kgw/kgda}, h_1 = 26.31 \text{ kJ/kgda}$$

a) Since the air is supplied to the room at  $12^\circ\text{C}$ , the mass flow rate of supply air  $m_3$  is obtained from sensible energy balance across the room, i.e.,

$$m_3 = \frac{Q_{s,r}}{C_{pm}(t_i - t_3)} = \frac{60}{1.0216(24 - 12)} = 4.894 \text{ kg/s} \quad (\text{Ans.})$$

The moisture content of supply air is obtained from latent energy balance across the room as:

$$W_s = W_i - \frac{Q_{l,r}}{m_3 h_{fg}} = 0.0093 - \frac{12}{4.894 \times 2501} = 0.0083 \text{ kgw/kgda}$$

Since the fresh air takes care of the entire latent load, the heat transfer across coil 2 is only sensible heat transfer. This implies that:

$$W_2 = W_3 = 0.0083 \text{ kgw/kgda}$$

Applying mass balance across the mixing of re-circulated and fresh air (1-2), we obtain:

$$m_1 W_1 + (m_2 - m_1) W_i = m_2 W_2$$

From the above equation, we get  $m_1$  as:

$$m_1 = m_2 (W_i - W_2) / (W_i - W_1) = 1.73 \text{ kg/s}$$

Hence the mass flow rate of re-circulated air is:

$$m_{rc} = m_2 - m_1 = (4.894 - 1.73) = 3.164 \text{ kg/s}$$

b) From energy balance across the mixing process 1-2, assuming the variation in cpm to be negligible, the temperature of mixed air at 2 is given by:

$$t_2 = (m_1 t_1 + m_{rc} t_i) / m_2 = 19.05^\circ\text{C} \quad (\text{Ans.})$$

From total enthalpy balance for the mixing process, the enthalpy of mixed air at 2 is:

$$h_2 = (m_1 h_1 + m_{rc} h_i) / m_2 = 40.11 \text{ kJ/kgda} \quad (\text{Ans.})$$

c) From energy balance, cooling capacity of 1<sup>st</sup> cooler coil is given by:

$$Q_{c,1} = m_1(h_o - h_1) = 1.73 \times (68.21 - 26.31) = 72.49 \text{ kW} \quad (\text{Ans.})$$

From energy balance across the 2<sup>nd</sup> cooler coil, the cooling capacity of the second coil is given by:

$$Q_{c,2} = m_2 \cdot c_{pm}(t_2 - t_3) = 4.894 \times 1.0216 \times (19.05 - 12.0) = 35.25 \text{ kW} \quad (\text{Ans.})$$

**Comment:** It can be seen that the combined cooling capacity ( $72.49 + 35.25 = 107.74 \text{ kW}$ ) is larger than the total cooling load on the building ( $60 + 12 = 72 \text{ kW}$ ). The difference between these two quantities ( $107.74 - 72 = 35.74 \text{ kW}$ ) is equal to the cooling capacity required to reduce the enthalpy of the fresh air from outdoor conditions to the required indoor conditions. This is the penalty one has to pay for providing fresh air to the conditioned space. Larger the fresh air requirement, larger will be the required cooling capacity.

**6)** An air conditioned building has a sensible cooling load of 60 kW and latent load of 40 kW. The room is maintained at 24°C (DBT) and 50% RH, while the outside design conditions are: 34°C (DBT) and 40% RH. To satisfy the ventilation requirement, outdoor air is mixed with re-circulated air in the ratio of 1:3 (by mass). Since the latent load on the building is high, a reheat coil is used along with a cooling and dehumidifying coil. Air is supplied to the conditioned space at 14°C (DBT). If the by-pass factor of the cooling coil is 0.15 and the barometric pressure is 101.325 kPa, find: a) Mass flow rate of supply air, b) Required cooling capacity of the cooling coil and heating capacity of the reheat coil

**Ans.:** From psychrometric chart, the following properties are obtained:

Inside conditions:  $t_i = 24^\circ\text{C}$ (DBT) and  $\text{RH}_i = 50\%$

$$W_i = 0.0093 \text{ kgw/kgda}, h_i = 47.66 \text{ kJ/kgda}$$

outside conditions:  $t_o = 34^\circ\text{C}$ (DBT) and  $\text{RH}_o = 40\%$

$$W_o = 0.01335 \text{ kgw/kgda}, h_o = 68.21 \text{ kJ/kgda}$$

Since the air is supplied to the room at 12°C, the mass flow rate of supply air  $m_3$  is obtained from sensible energy balance across the room, i.e.,

$$m_3 = \frac{Q_{s,r}}{C_{pm}(t_i - t_s)} = \frac{60}{1.0216(24 - 14)} = 5.873 \text{ kg/s} \quad (\text{Ans.})$$

The moisture content of supply air is obtained from latent energy balance across the room as:

$$W_s = W_i - \frac{Q_{l,r}}{m_3 h_{fg}} = 0.0093 - \frac{40}{5.873 \times 2501} = 0.0066 \text{ kgw/kgda}$$

Since 25% of the supply air is fresh air, the mass flow rates of fresh and re-circulated air are:

$$m_o = 0.25 \times 5.873 = 1.468 \text{ kg/s and } m_{rc} = 0.75 \times 5.873 = 4.405 \text{ kg/s} \quad (\text{Ans.})$$

b) From sensible energy balance for the mixing process of fresh air with re-circulated air (Fig.30.4), we obtain the mixed air conditions as:

$$t_m = (m_o \cdot t_o + m_{rc} \cdot t_i) / (m_o + m_{rc}) = 26.5^\circ\text{C}$$

$$W_m = (m_o \cdot W_o + m_{rc} \cdot W_i) / (m_o + m_{rc}) = 0.0103 \text{ kgw/kgda}$$

$$h_m = (m_o \cdot h_o + m_{rc} \cdot h_i) / (m_o + m_{rc}) = 52.75 \text{ kJ/kgda}$$

Since heating in the reheat coil is a sensible heating process, the moisture content of air remains constant during this process. Then from Fig.30.4., writing the by-pass factor in terms of humidity ratios as:

$$X = \frac{(W_s - W_{ADP})}{(W_m - W_{ADP})} = \frac{(0.0066 - W_{ADP})}{(0.0103 - W_{ADP})} = 0.15$$

From the above expression, the humidity ratio at coil ADP condition is found to be:

$$W_{ADP} = (W_s - X \cdot W_m) / (1 - X) = (0.0066 - 0.15 \times 0.0103) / (1.0 - 0.15) = 0.00595 \text{ kgw/kgda}$$

The Coil ADP is the saturation temperature corresponding to a humidity ratio of  $W_{ADP}$ , hence, from psychrometric chart or using psychrometric equations, it is found to be:

$$t_{ADP} = 6.38^\circ\text{C}$$

Hence, the temperature of air at the exit of the cooling coil ( $t_c$  in Fig.30.4) is obtained from the by-pass factor as:

$$t_c = t_{ADP} + X (t_m - t_{ADP}) = 9.4^\circ\text{C}$$

From  $W_c (= W_s)$  and  $t_c$ , the enthalpy of air at the exit of the cooling coil is found from psychrometric chart as:

$$h_c = 26.02 \text{ kJ/kgda}$$

Hence, from energy balance across cooling coil and reheater:

$$\text{Required capacity of cooling coil, } Q_c = m_s (h_m - h_c) = 157.0 \text{ kW} \quad (\text{Ans.})$$

$$\text{Required capacity of reheat coil, } Q_{rh} = m_s c_{pm} (t_s - t_c) = 27.6 \text{ kW} \quad (\text{Ans.})$$

# Lesson

31

## Evaporative, Winter And All Year Air Conditioning Systems



## The specific objectives of this lecture are to:

1. Introduce evaporative cooling systems (*Section 31.1*)
2. Classify evaporative cooling systems (*Section 31.2*)
3. Discuss the characteristics of direct evaporative cooling systems (*Section 31.2.1*)
4. Discuss the characteristics of indirect evaporative cooling systems (*Section 31.2.2*)
5. Discuss the characteristics of multi-stage evaporative cooling systems (*Section 31.2.3*)
6. Discuss advantages and disadvantages of evaporative cooling systems (*Section 31.3*)
7. Discuss the applicability of evaporative cooling systems (*Section 31.4*)
8. Describe winter air conditioning systems (*Section 31.5*)
9. Describe all year air conditioning systems (*Section 31.6*)

At the end of the lecture, the student should be able to:

1. Explain the working principle of direct, indirect and multi-stage evaporative cooling systems
2. Perform psychrometric calculations on evaporative cooling systems
3. List the advantages and disadvantages of evaporative cooling systems
4. Evaluate the applicability of evaporative cooling systems based on climatic conditions
5. Describe winter air conditioning systems and perform psychrometric calculations on these systems
6. Describe all year air conditioning systems

### 31.1. Introduction to evaporative air conditioning systems:

Summer air conditioning systems capable of maintaining exactly the required conditions in the conditioned space are expensive to own and operate. Sometimes, partially effective systems may yield the best results in terms of comfort and cost. Evaporative air conditioning systems are inexpensive and offer an attractive alternative to the conventional summer air conditioning systems in places, which are hot and dry. Evaporative air conditioning systems also find applications in hot industrial environments where the use of conventional air conditioning systems becomes prohibitively expensive.

Evaporative cooling has been in use for many centuries in countries such as India for cooling water and for providing thermal comfort in hot and dry regions. This system is based on the principle that when moist but unsaturated air comes in contact with a wetted surface whose temperature is higher than the dew point temperature of air, some water from the wetted surface evaporates into air. The latent heat of evaporation is taken from

water, air or both of them. In this process, the air loses sensible heat but gains latent heat due to transfer of water vapour. Thus the air gets cooled and humidified. The cooled and humidified air can be used for providing thermal comfort.

## 31.2. Classification of evaporative cooling systems:

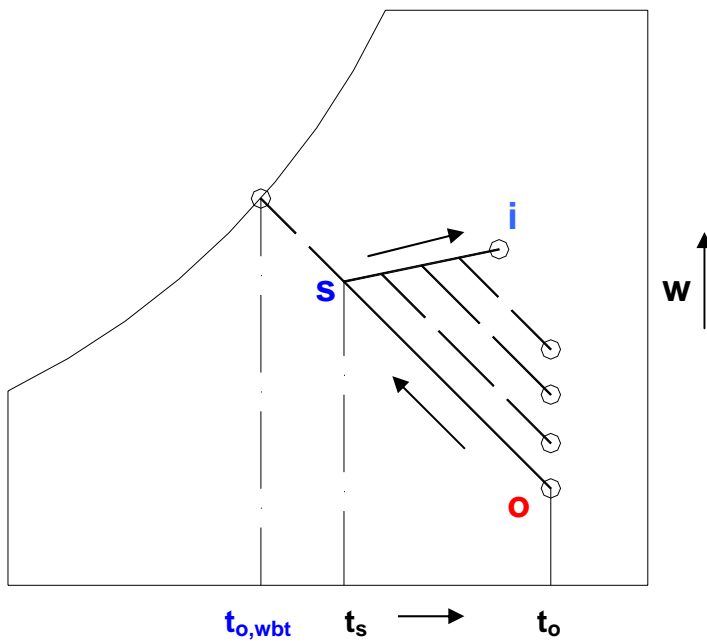
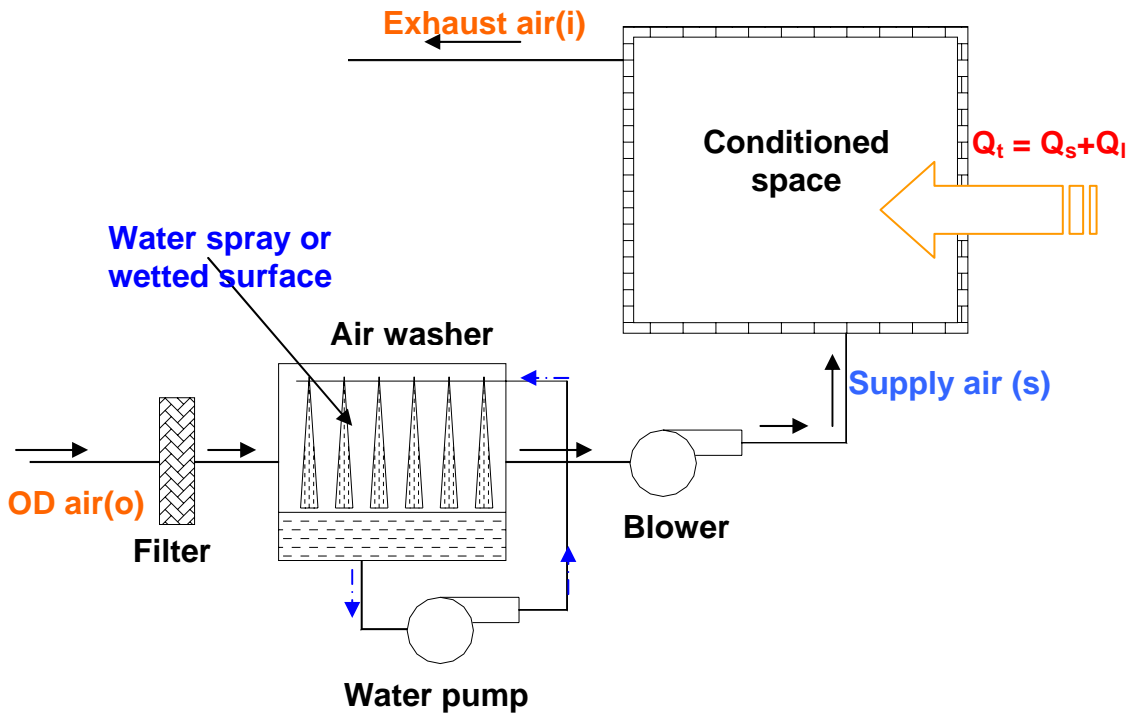
The principle of evaporative cooling can be used in several ways. Cooling can be provided by:

1. Direct evaporation process
2. Indirect evaporation process, or
3. A combination or multi-stage systems

### 31.2.1. Direct evaporative cooling systems:

In direct evaporative cooling, the process or conditioned air comes in direct contact with the wetted surface, and gets cooled and humidified. Figure 31.1 shows the schematic of an elementary direct, evaporative cooling system and the process on a psychrometric chart. As shown in the figure, hot and dry outdoor air is first filtered and then is brought in contact with the wetted surface or spray of water droplets in the air washer. The air gets cooled and dehumidified due to simultaneous transfer of sensible and latent heats between air and water (**process o-s**). The cooled and humidified air is supplied to the conditioned space, where it extracts the sensible and latent heat from the conditioned space (**process s-i**). Finally the air is exhausted at state i. In an ideal case when the air washer is perfectly insulated and an infinite amount of contact area is available between air and the wetted surface, then the cooling and humidification process follows the constant wet bulb temperature line and the temperature at the exit of the air washer is equal to the wet bulb temperature of the entering air ( $t_{o,wbt}$ ), i.e., the process becomes an adiabatic saturation process. However, in an actual system the temperature at the exit of the air washer will be higher than the inlet wet bulb temperature due to heat leaks from the surroundings and also due to finite contact area. One can define the saturation efficiency or effectiveness of the evaporative cooling system  $\varepsilon$  as:

$$\varepsilon = \frac{(t_o - t_s)}{(t_o - t_{o,wbt})} \quad (31.1)$$



**Fig.31.1:** A direct, evaporative cooling system

Depending upon the design aspects of the evaporative cooling system, the effectiveness may vary from 50% (for simple drip type) to about 90% (for efficient spray pads or air washers).

The amount of supply air required  $\dot{m}_s$  can be obtained by writing energy balance equation for the conditioned space, i.e.,

$$\dot{m}_s = \frac{Q_t}{(h_i - h_s)} \quad (31.2)$$

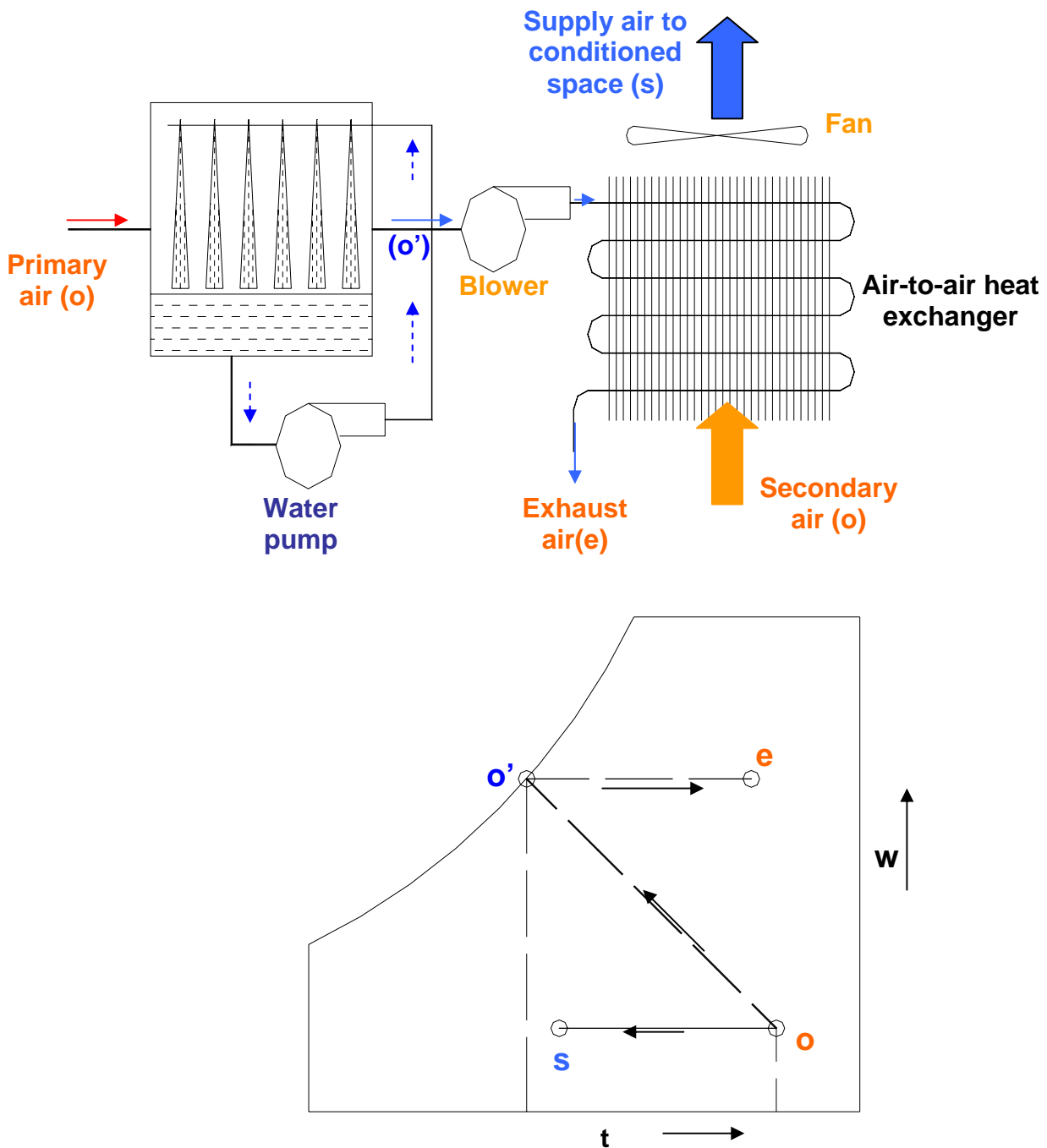
where  $Q_t$  is the total heat transfer rate (sensible + latent) to the building,  $h_i$  and  $h_s$  are the specific enthalpies of return air and supply air, respectively.

Compared to the conventional refrigeration based air conditioning systems, the amount of airflow rate required for a given amount of cooling is much larger in case of evaporative cooling systems. As shown by the above equation and also from Fig.30.1, it is clear that for a given outdoor dry bulb temperature, as the moisture content of outdoor air increases, the required amount of supply air flow rate increases rapidly. And at a threshold moisture content value, the evaporative coolers cannot provide comfort as the cooling and humidification line lies above the conditioned space condition 'i'. Thus evaporative coolers are very useful essentially in dry climates, whereas the conventional refrigeration based air conditioning systems can be used in any type of climate.

### 31.2.2. Indirect evaporative cooling system:

Figure 30.2 shows the schematic of a basic, indirect evaporative cooling system and the process on a psychrometric chart. As shown in the figure, in an indirect evaporative cooling process, two streams of air - **primary and secondary** are used. The primary air stream becomes cooled and humidified by coming in direct contact with the wetted surface (**o-o'**), while the secondary stream which is used as supply air to the conditioned space, decreases its temperature by exchanging only sensible heat with the cooled and humidified air stream (**o-s**). Thus the moisture content of the supply air remains constant in an indirect evaporative cooling system, while its temperature drops. Obviously, everything else remaining constant, the temperature drop obtained in a direct evaporative cooling system is larger compared to that obtained in an indirect system, in addition the direct evaporative cooling system is also simpler and hence, relatively inexpensive. However, since the moisture content of supply air remains constant in an indirect evaporation process, this may provide greater degree of comfort in regions with higher humidity ratio. In modern day indirect evaporative coolers, the conditioned air flows through tubes or plates made of non-corroding plastic materials such as polystyrene (PS) or polyvinyl chloride (PVC). On the outside of the plastic tubes or plates thin film of water is maintained. Water from the liquid film on the outside of the tubes or plates evaporates into the air blowing over it (primary air) and cools the conditioned air flowing through the tubes or plates sensibly. Even though the plastic materials used in these

coolers have low thermal conductivity, the high external heat transfer coefficient due to evaporation of water more than makes up for this. The commercially available indirect evaporative coolers have saturation efficiency as high as 80%.



**Fig.31.2:** An indirect, evaporative cooling system

### 31.2.3: Multi-stage evaporative cooling systems:

Several modifications are possible which improve efficiency of the evaporative cooling systems significantly. One simple improvement is to **sensibly cool the outdoor air** before sending it to the evaporative cooler by exchanging heat with the exhaust air from the conditioned space. This is possible since the temperature of the outdoor air will be much higher than the

exhaust air. It is also possible to mix outdoor and return air in some proportion so that the temperature at the inlet to the evaporative cooler can be reduced, thereby improving the performance. Several other schemes of increasing complexity have been suggested to get the maximum possible benefit from the evaporative cooling systems. For example, one can use multistage evaporative cooling systems and obtain supply air temperatures lower than the wet bulb temperature of the outdoor air. Thus multistage systems can be used even in locations where the humidity levels are high.

Figure 30.3 shows a typical two-stage evaporative cooling system and the process on a psychrometric chart. As shown in the figure, in the first stage the primary air cooled and humidified ( $o-o'$ ) due to direct contact with a wet surface cools the secondary air sensibly ( $o-1$ ) in a heat exchanger. In the second stage, the secondary air stream is further cooled by a direct evaporation process ( $1-2$ ). Thus in an ideal case, the final exit temperature of the supply air ( $t_2$ ) is several degrees lower than the wet bulb temperature of the inlet air to the system ( $t_o$ ).

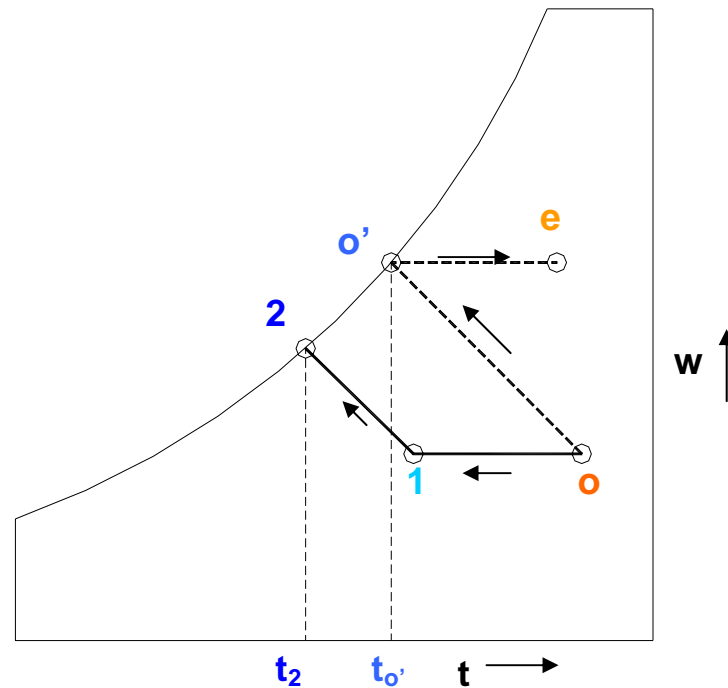
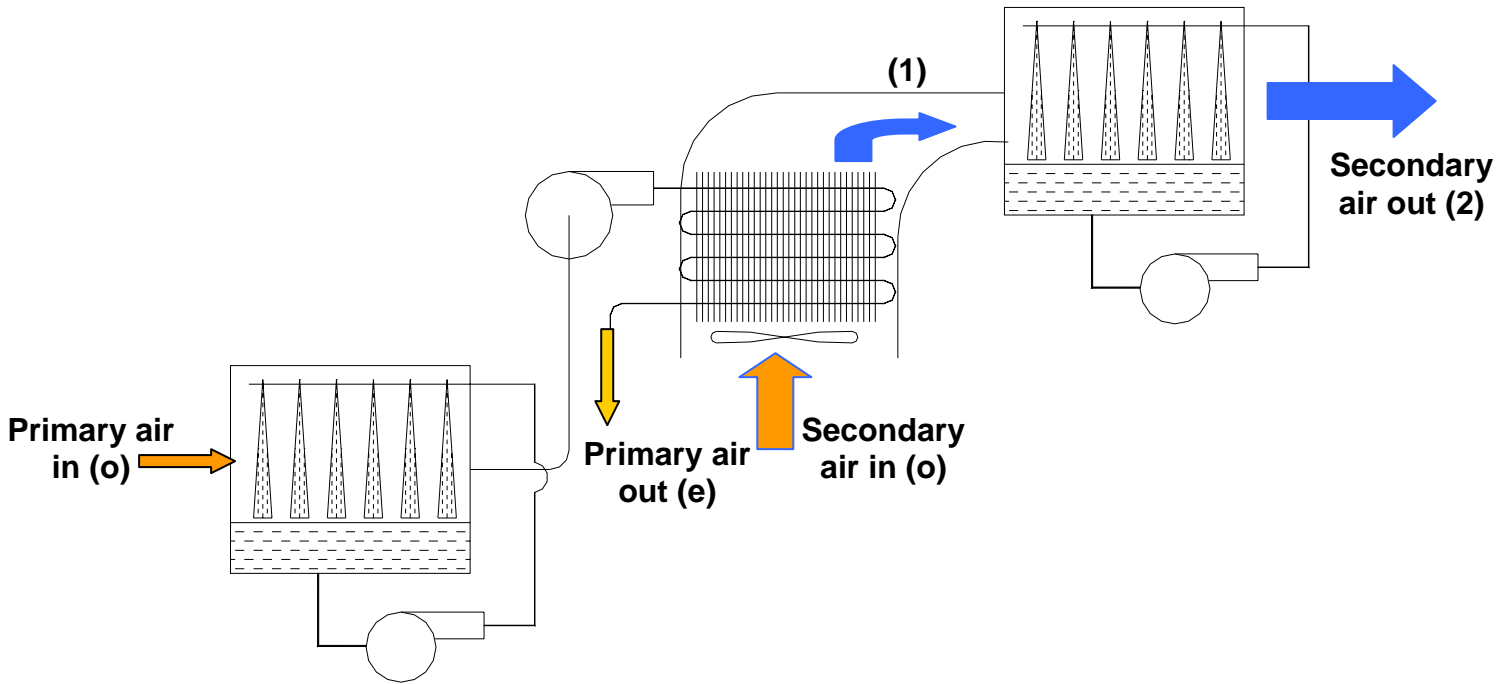
### 31.3. Advantages and disadvantages of evaporative cooling systems:

Compared to the conventional refrigeration based air conditioning systems, the evaporative cooling systems offer the following advantages:

1. Lower equipment and installation costs
2. Substantially lower operating and power costs. Energy savings can be as high as 75 %
3. Ease of fabrication and installation
4. Lower maintenance costs
5. Ensures a very good ventilation due to the large air flow rates involved, hence, are very good especially in 100 % outdoor air applications
6. Better air distribution in the conditioned space due to higher flow rates
7. The fans/blowers create positive pressures in the conditioned space, so that infiltration of outside air is prevented
8. Very environment friendly as no harmful chemicals are used

Compared to the conventional systems, the evaporative cooling systems suffer from the following disadvantages:

1. The moisture level in the conditioned space could be higher, hence, direct evaporative coolers are not good when low humidity levels in the conditioned space is required. However, the indirect evaporative cooler can be used without increasing humidity
2. Since the required air flow rates are much larger, this may create draft and/or high noise levels in the conditioned space
3. Precise control of temperature and humidity in the conditioned space is not possible
4. May lead to health problems due to micro-organisms if the water used is not clean or the wetted surfaces are not maintained properly.



**Fig.31.3:** A two-stage evaporative cooling system

### 31.4. Applicability of evaporative cooling systems:

As mentioned before, evaporative cooling systems are ideal in hot and dry places, i.e., in places where the dry bulb temperature is high and the coincident wet bulb temperature is low. However, there are no clear-cut rules as to where these systems can or cannot be used. Evaporative cooling can provide some measure of comfort in any location. However, in many locations where the humidity levels are very high, stand-alone evaporative cooling systems cannot be used for providing thermal comfort especially in residences, office buildings etc. One of the older rules-of-thumb used in USA

specifies that evaporative cooling systems can be used wherever the **average noon relative humidity during July is less than 40%**. However, experience shows that evaporative coolers can be used even in locations where the relative humidity is higher than 40%. A more recent guideline suggests that evaporative cooling can be used in locations where the **summer design wet bulb temperatures are less than about 24°C (75°F)**. It is generally observed that evaporative coolers can compete with conventional systems when the noon relative humidity during July is less than 40%, hence should definitely be considered as a viable alternative, whereas these systems can be used in places where the noon relative humidity is higher than 40% but the design WBT is lower than 24°C, with a greater sacrifice of comfort. It should be mentioned that both these guidelines have been developed for direct evaporative cooling systems. Indirect evaporative coolers can be used over a slightly broader range. Evaporative air conditioning systems can also be used over a broader range of outdoor conditions in factories, industries and commercial buildings, where the comfort criteria is not so rigid (temperatures as high as 30°C in the conditioned space are acceptable). Evaporative air conditioning systems are highly suitable in applications requiring large amounts of ventilation and/or high humidity in the conditioned space such as textile mills, foundries, dry cleaning plants etc.

Evaporative cooling can be combined with a conventional refrigeration based air conditioning systems leading to substantial savings in energy consumption, if the outside conditions are favorable. Again, a number of possibilities exist. For example, the outdoor air can be first cooled in an evaporative cooler and then mixed with the re-circulating air from the conditioned space and then cooled further in the conventional refrigerant or chilled water coil.

### 31.5. Winter Air Conditioning Systems

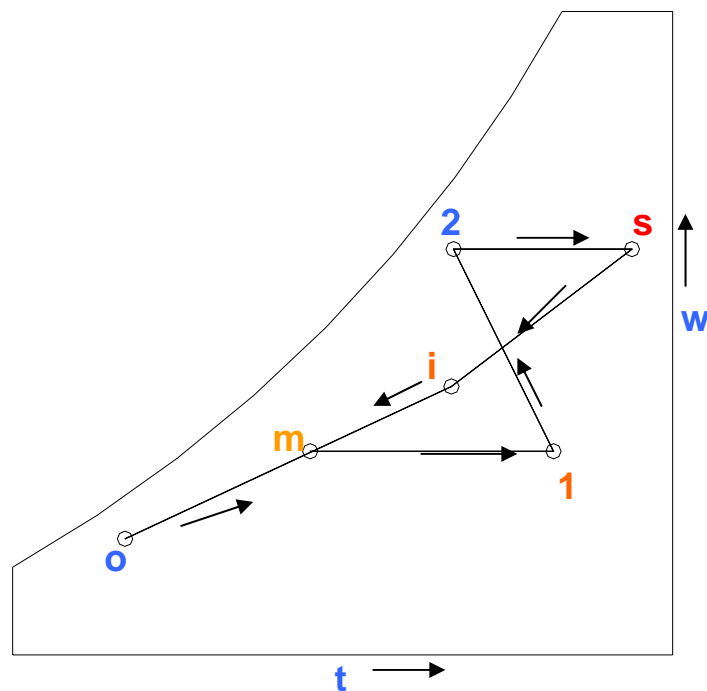
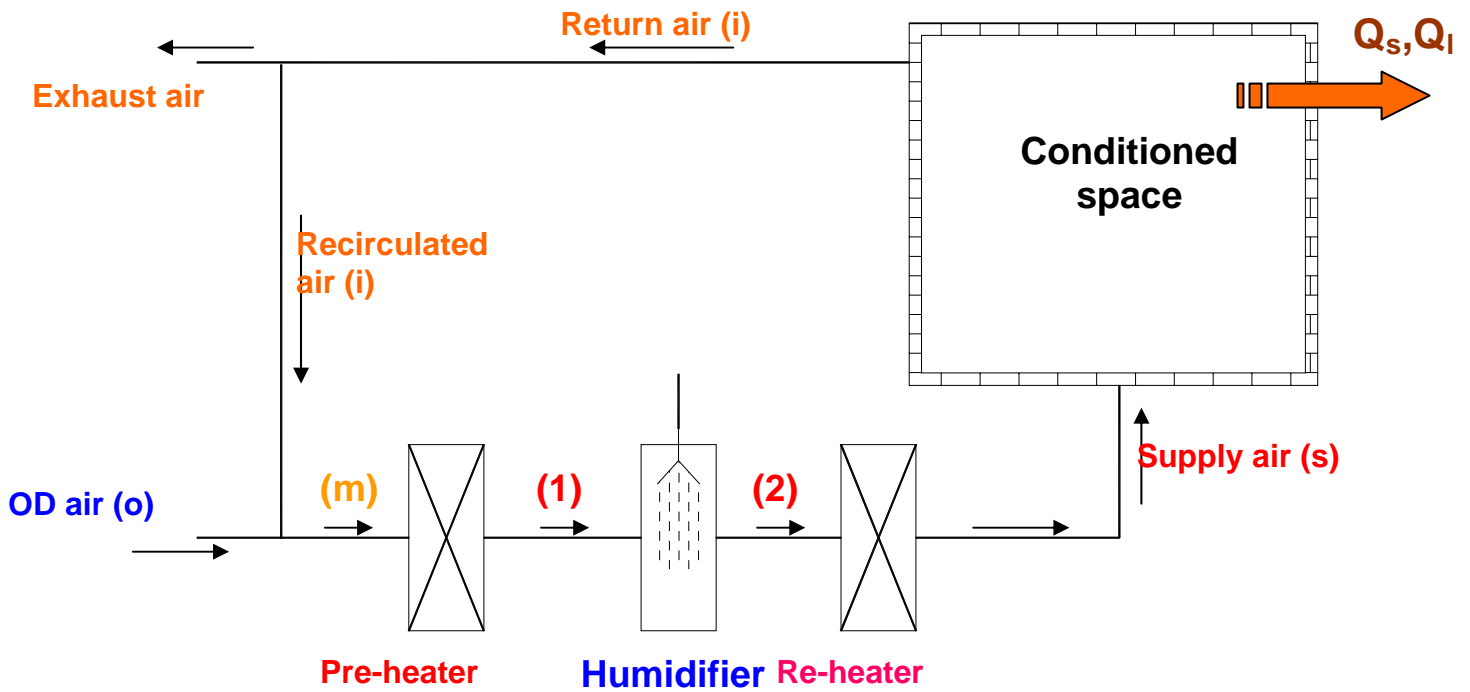
In winter the outside conditions are cold and dry. As a result, there will be a continuous transfer of sensible heat as well as moisture (latent heat) from the buildings to the outside. Hence, in order to maintain required comfort conditions in the occupied space an air conditioning system is required which can offset the sensible and latent heat losses from the building. Air supplied to the conditioned space is heated and humidified in the winter air conditioning system to the required level of temperature and moisture content depending upon the sensible and latent heat losses from the building. In winter the heat losses from the conditioned space are partially offset by solar and internal heat gains. Thus in a conservative design of winter A/C systems, the effects of solar radiation and internal heat gain are not considered.

Heating and humidification of air can be achieved by different schemes. Figure 31.4 shows one such scheme along with the cycle on psychrometric chart. As shown in the figure, the mixed air (mixture of return and outdoor air) is first pre-heated (**m-1**) in the pre-heater, then humidified using a humidifier or an air washer (**1-2**) and then finally reheated in the re-heater (**2-s**). The reheated air at state 's' is supplied to the conditioned space.

The flow rate of supply air should be such that when released into the conditioned space at state 's', it should be able to maintain the conditioned



space at state I and offset the sensible and latent heat losses ( $Q_s$  and  $Q_l$ ). Pre-heating of air is advantageous as it ensures that water in the humidifier/air washer does not freeze. In addition, by controlling the heat supplied in the pre-heater one can control the moisture content in the conditioned space.



**Fig.31.4:** A winter air conditioning system with a pre-heater

The humidification of air can be achieved in several ways, e.g. by bringing the air in contact with a wetted surface, or with droplets of water as in an air washer, by adding aerosol sized water droplets directly to air or by direct addition of dry saturated or superheated steam. Humidification by direct contact with a wetted surface or by using an air washer are not recommended for comfort applications or for other applications where people are present in the conditioned space due to potential health hazards by the presence of micro-organisms in water. The most common method of humidifying air for these applications is by direct addition of dry steam to air. When air is humidified by contact with wetted surface as in an air washer, then temperature of air decreases as its humidity increases due to simultaneous transfer of sensible and latent heat. If the air washer functions as an adiabatic saturator, then humidification proceeds along the constant wet bulb temperature line. However, **when air is humidified by directly adding dry, saturated steam, then the humidification proceeds close to the constant dry bulb temperature line.** The final state of air is always obtained by applying conservation of mass (water) and conservation of energy equations to the humidification process.

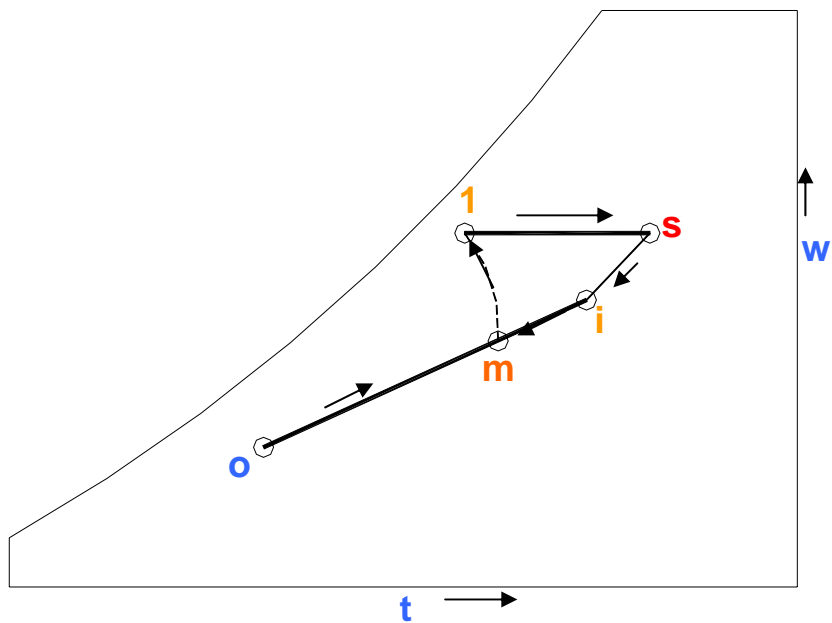
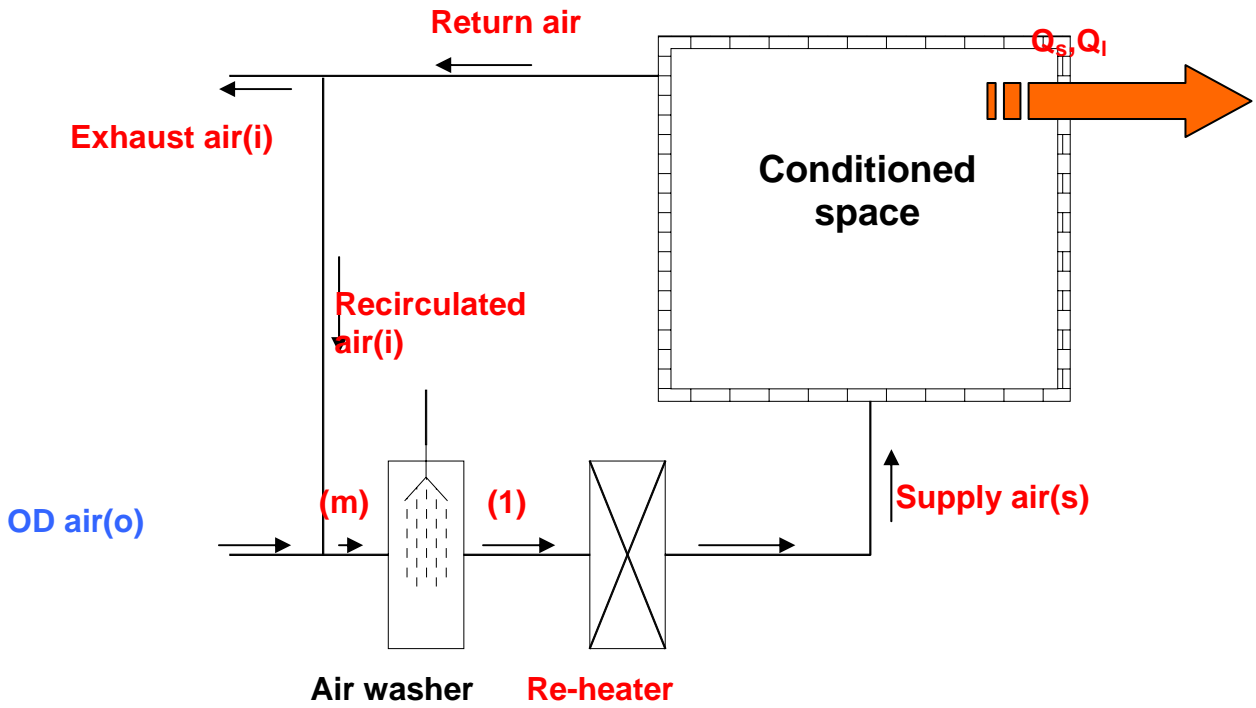
By applying energy balance across the conditioned space, at steady state, the sensible and latent heat losses from the building can be written as:

$$Q_s = \dot{m}_s c_{pm}(t_s - t_i) \quad (31.3)$$

$$Q_l = \dot{m}_s h_{fg}(w_s - w_i) \quad (31.4)$$

where  $\dot{m}_s$  is the mass flow rate of supply air,  $c_{pm}$  is the specific heat of air,  $h_{fg}$  is the latent heat of vapourization of water,  $w_s$  and  $w_i$  are the supply and return air humidity ratios and  $t_s$ ,  $t_i$  are the supply and return temperatures of air. By applying mass and/or energy balance equations across individual components, the amount of sensible heat transfer rate to the pre-heater and re-heater and the amount of moisture to be added in the humidifier can easily be calculated.

Figure 31.5 shows another scheme that can also be used for heating and humidification of air as required in a winter air conditioning system. As shown in the figure, this system does not consist of a pre-heater. The mixed air is directly humidified using an air washer (**m-1**) and is then reheated (**1-s**) before supplying it to the conditioned space. Though this system is simpler compared to the previous one, it suffers from disadvantages such as possibility of water freezing in the air washer when large amount of cold outdoor air is used and also from health hazards to the occupants if the water used in the air washer is not clean. Hence this system is not recommended for comfort conditioning but can be used in applications where the air temperatures at the inlet to the air washer are above 0°C and the conditioned space is used for products or processes, but not for providing personnel comfort.

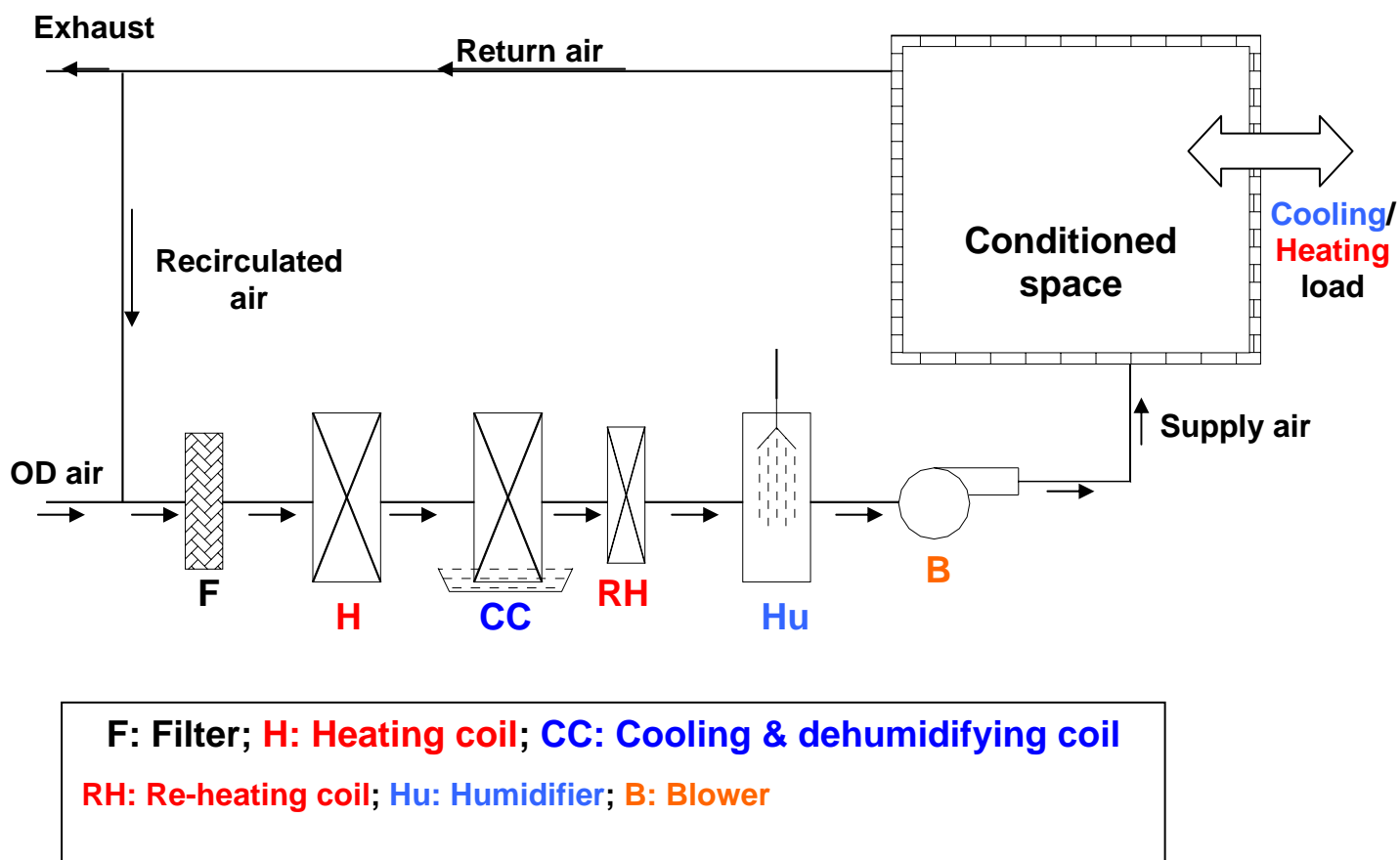


**Fig.31.5:** A winter air conditioning system without a pre-heater

Actual winter air conditioning systems, in addition to the basic components shown above, consist of fans or blowers for air circulation and filters for purifying air. The fan or blower introduces sensible heat into the air stream as all the electrical power input to the fan is finally dissipated in the form of heat.

### 31.6. All year (complete) air conditioning systems:

Figure 30.6 shows a complete air conditioning system that can be used for providing air conditioning throughout the year, i.e., during summer as well as winter. As shown in the figure, the system consists of a filter, a heating coil, a cooling & dehumidifying coil, a re-heating coil, a humidifier and a blower. In addition to these, actual systems consist of several other accessories such as dampers for controlling flow rates of re-circulated and outdoor (OD) air, control systems for controlling the space conditions, safety devices etc. Large air conditioning systems use blowers in the return air stream also. Generally, during summer the heating and humidifying coils remain inactive, while during winter the cooling and dehumidifying coil remains inactive. However, in some applications for precise control of conditions in the conditioned space all the coils may have to be made active. The blowers will remain active throughout the year, as air has to be circulated during summer as well as during winter. When the outdoor conditions are favourable, it is possible to maintain comfort conditions by using filtered outdoor air alone, in which case only the blowers will be running and all the coils will be inactive leading to significant savings in energy consumption. A control system is required which changes-over the system from winter operation to summer operation or vice versa depending upon the outdoor conditions.



*Fig.31.6: An all year air conditioning system*

## Questions and answers:

1. Which of the following statements are TRUE?

- a) Evaporative cooling systems are attractive for hot and humid climates
- b) Evaporative cooling systems are attractive for hot and dry climates
- c) Evaporative cooling systems are ideal for comfort applications
- d) Evaporative cooling systems are ideal for several industrial applications

**Ans.: b) and d)**

2. Which of the following statements are TRUE?

- a) In a direct evaporative cooling system, the lowest possible temperature is the wet bulb temperature corresponding to the outdoor air
- b) In a direct evaporative cooling system, the lowest possible temperature is the dew point temperature corresponding to the outdoor air
- c) In a direct evaporative cooling system, cooled and humidified air is supplied to the conditioned space
- d) In a direct evaporative cooling system, cooled and dehumidified air is supplied to the conditioned space

**Ans.: a) and c)**

3. Which of the following statements are TRUE?

- a) In an indirect evaporative cooling system, the air supplied to the conditioned space is at a lower temperature, but higher humidity ratio
- b) In an indirect evaporative cooling system, the air supplied to the conditioned space is at a lower temperature and at a humidity ratio corresponding to the outdoor air
- c) Compared to direct evaporative cooling systems, it is possible to achieve lower supply air temperatures in simple indirect evaporative coolers
- d) In multi-stage evaporative cooling systems, it is possible to cool the air to a temperature lower than the entering air WBT

**Ans.: b) and d)**

4. Which of the following statements are TRUE?

- a) Evaporative cooling systems are environment friendly
- b) Evaporative cooling systems offer lower initial and lower running costs
- c) Evaporative cooling systems are easier to maintain and fabricate
- d) Evaporative systems provide better control on indoor climate

**Ans.: a), b) and c)**

5. Which of the following statements are TRUE?

- a) Direct evaporative cooling systems are attractive in places where the summer design WBT is greater than 24°C
- b) Direct evaporative cooling systems are attractive in places where the summer design WBT is less than 24°C
- c) Indirect evaporative cooling systems can be used over an extended range of climatic conditions
- d) A combination of evaporative cooling system with conventional air conditioning system can offer better overall performance

**Ans.: b), c) and d)**

6. Which of the following statements are TRUE?

- a) In winter air conditioning systems, heated and dehumidified air is supplied to the conditioned space
- b) In winter air conditioning systems, heated and humidified air is supplied to the conditioned space
- c) A pre-heater is recommended in winter air conditioning systems to improve overall efficiency of the system
- d) A pre-heater is recommended in winter air conditioning systems to prevent freezing of water in the humidifier and for better control

**Ans.: b) and d)**

7. Which of the following statements are TRUE?

- a) When humidification is done using an air washer, the temperature of air drops during humidification
- b) When humidification is done using an air washer, the temperature of air rises during humidification
- c) When humidification is carried out by adding dry steam, the temperature of air remains close to the WBT of entering air
- d) When humidification is carried out by adding dry steam, the temperature of air remains close to the DBT of entering air

**Ans.: a) and d)**

8. Which of the following statements are TRUE?

- a) An all year air conditioning system can be used either as a summer air conditioning system or as a winter air conditioning system
- b) When an all year air conditioning system is used during summer, the heaters are always switched-off
- c) When an all year air conditioning system is used during winter, the cooling and dehumidification coils are switched-off
- d) In an all year air conditioning systems, the blowers are always on

**Ans.: a), c) and d)**

9. A large warehouse located at an altitude of 1500 m has to be maintained at a DBT of 27°C and a relative humidity of 50% using a direct evaporative cooling system. The outdoor conditions are 33°C (DBT) and 15°C (WBT). The cooling load on the warehouse is 352 kW. A supply fan located in the downstream of the evaporative cooler adds 15 kW of heat. Find the required mass flow rate of air. Assume the process in evaporative cooler to follow a constant WBT.

**Ans.:**

At 1500m, the barometric pressure is equal to **84.436 kPa**.

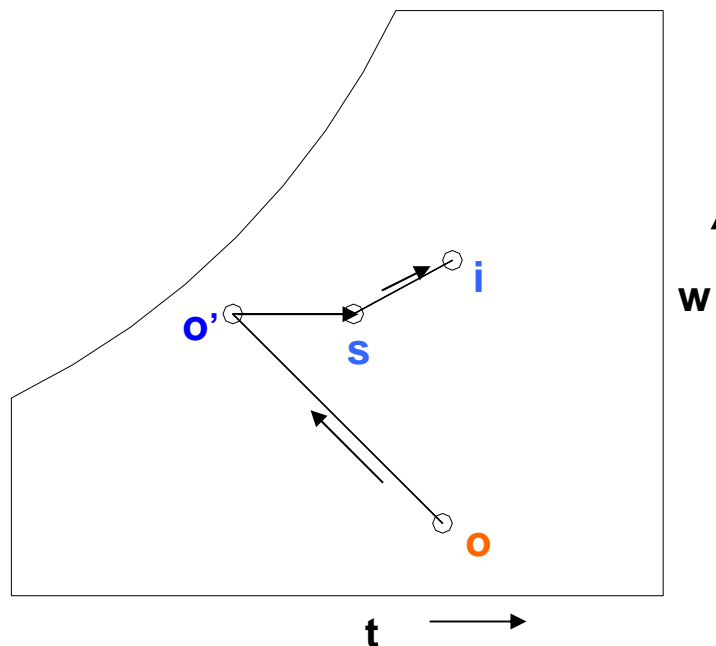
Inlet conditions to the evaporative cooling system are the outdoor conditions:

$$t_o = 33^\circ\text{C}, \text{WBT}_o = 15^\circ\text{C}$$

At these conditions and a barometric pressure of 84.436 kPa, the enthalpy of outdoor air is obtained using psychrometric equations<sup>1</sup> as:

$$h_o = 46.67 \text{ kJ/kgda}$$

The above system is shown on psychrometric chart in Fig.31.6



**Fig.31.7**

Assuming the evaporative process to follow a constant WBT and hence nearly a constant enthalpy line,

$$h_o = h_{o'} = 46.67 \text{ kJ/kgda}$$

<sup>1</sup> Standard psychrometric chart cannot be used here as the barometric pressure is not 1 atm.

Applying energy balance for the sensible heating process in the fan (process o'-s) and heating and humidification process through the conditioned space (process s-i), we obtain:

$$m_s(h_s - h_o) = 15 = \text{sensible heat added due to fan} \quad (\text{E.1})$$

$$m_s(h_i - h_s) = 352 = \text{cooling load on the room} \quad (\text{E.2})$$

From psychrometric equations, for the inside condition of the warehouse (DBT=27°C and RH = 50%), the enthalpy  $h_i$  is found from psychrometric equations as:

$$h_i = 61.38 \text{ kJ/kgda}$$

We have two unknowns ( $m_s$  and  $h_s$ ) and two equations (E.1 and E.2), hence solving the equations simultaneously yields:

$$m_s = 24.94 \text{ kJ/kg and } h_s = 47.27 \text{ kJ/kgda} \quad (\text{Ans.})$$

**10.** A winter air conditioning system maintains a building at 21°C and 40% RH. The outdoor conditions are 0°C (DBT) and 100% RH. The sensible load on the building is 100 kW, while the latent heating load is 25 kW. In the air conditioning system, 50% of the outdoor air (by mass) is mixed with 50% of the room air. The mixed air is heated in a pre-heater to 25°C and then required amount of dry saturated steam at 1 atm. pressure is added to the pre-heated air in a humidifier. The humidified air is then heated to supply temperature of 45°C and is then supplied to the room. Find a) The required mass flow rate of supply air, b) Required amount of steam to be added, and c) Required heat input in pre-heater and re-heater. Barometric pressure = 1atm.

Ans.: From psychrometric chart the following properties are obtained:

Outdoor conditions: 0°C (DBT) and 100% RH

$$W_o = 0.00377 \text{ kgw/kgda, } h_o = 9.439 \text{ kJ/kgda}$$

Indoor conditions: 21°C (DBT) and 40% RH

$$W_i = 0.00617 \text{ kgw/kgda, } h_i = 36.66 \text{ kJ/kgda}$$

Since equal amounts of outdoor and indoor air are mixed:

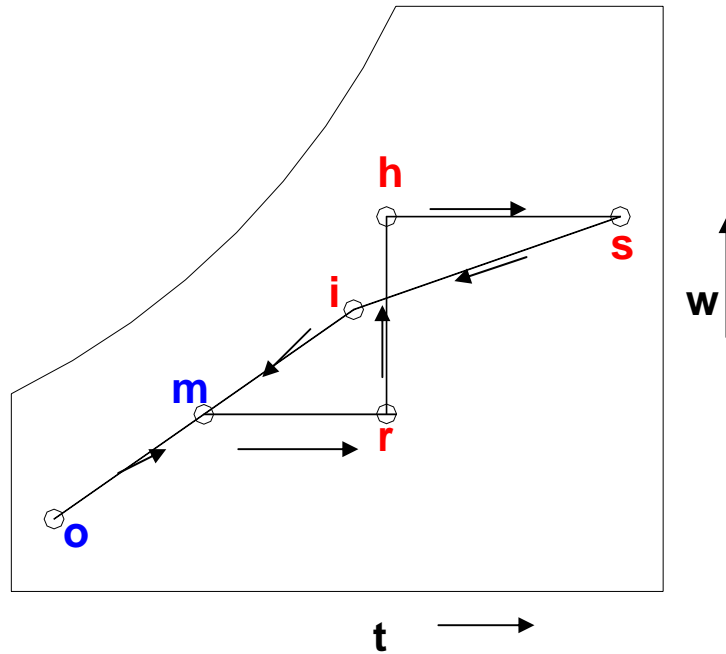
$$t_m = 10.5^\circ\text{C, } W_m = 0.00497 \text{ kgw/kgda, } h_m = 23.05 \text{ kJ/kgda}$$

From sensible energy balance across the room (Process s-i) in Fig.31.8:

a) Required mass flow rate of supply air is:

$$m_s = Q_s / \{c_{pm}(t_s - t_i)\} = 100 / \{1.0216(45 - 21)\} = 4.08 \text{ kg/s} \quad (\text{Ans.})$$





**Fig.31.8**

From latent energy balance for process s-i, the humidity ratio of supply air is found to be:

$$W_s = W_i + Ql/(h_{fg}.m_s) = 0.00617 + 25/(2501 \times 4.08) = 0.00862 \text{ kgw/kgda}$$

b) Required amount of steam to be added  $m_w$  is obtained from mass balance across the humidifier (process r-h) as:

$$m_w = m_s(W_s - W_m) = 4.08 \times (0.00862 - 0.00497) = 0.0149 \text{ kg/s} \quad (\text{Ans.})$$

c) Heat input to the pre-heater (process m-r) is obtained as:

$$Q_{ph} = m_s.c_{pm}(t_r - t_m) = 60.44 \text{ kW} \quad (\text{Ans.})$$

Heat input to the re-heater (process h-s) is obtained as:

$$Q_{rh} = m_s.c_{pm}(t_s - t_r) = 83.36 \text{ kW} \quad (\text{Ans.})$$

In the above example, it is assumed that during addition of steam, the dry bulb temperature of air remains constant. A simple check by using energy balance across the humidifier shows that this assumption is valid.

# Lesson

32

## Cooling And Heating Load Calculations - Estimation Of Solar Radiation

## The specific objectives of this lecture are to:

1. Introduction to cooling and heating load calculations (*Section 32.1*)
2. Solar radiation, solar constant and solar irradiation (*Section 32.2*)
3. Solar geometry, latitude, declination, hour angles, local solar time and total sunshine hours (*Section 32.2.4*)
4. Derived solar angles (*Section 32.2.5*)
5. Angle of incidence for horizontal, vertical and tilted surfaces (*Section 32.2.6*)
6. Calculation of direct, diffuse and reflected radiation using ASHRAE solar radiation model (*Section 32.3*)
7. Effect of clouds (*Section 32.4*)

At the end of the lecture, the student should be able to:

1. Explain the need for cooling and heating load calculations
2. Explain the importance of solar radiation in air conditioning
3. Define solar angles namely, latitude, declination and hour angles and calculate the same and estimate the time of sunrise, sunset and total sunshine hours at a given location on a given day
4. Define derived solar angles and express them in terms of basic solar angles
5. Calculate the angle of incidence for surfaces of any orientation
6. Estimate direct, diffuse, reflected and total solar irradiation incident on surfaces of any orientation using ASHRAE models
7. Explain the effects of clouds on incident solar radiation

### 32.1 Introduction:

The primary function of an air conditioning system is to maintain the conditioned space at required temperature, moisture content with due attention towards the air motion, air quality and noise. The required conditions are decided by the end use of the conditioned space, e.g. for providing thermal comfort to the occupants as in comfort air conditioning applications, for providing suitable conditions for a process or for manufacturing a product as in industrial air conditioning applications etc. The reason behind carrying out cooling and heating load calculations is to ensure that the cooling and heating equipment

designed or selected serves the intended purpose of maintaining the required conditions in the conditioned space. Design and/or selection of cooling and heating systems involve decisions regarding the required capacity of the equipment selected, type of the equipment etc. By carrying out cooling and heating load calculations one can estimate the capacity that will be required for various air conditioning equipment. For carrying out load calculations it is essential to have knowledge of various energy transfers that take place across the conditioned space, which will influence the required capacity of the air conditioning equipment. Cooling and heating load calculations involve a systematic step-wise procedure by following which one can estimate the various individual energy flows and finally the total energy flow across an air conditioned building.

## 32.2. Solar radiation:

In the study of air conditioning systems it is important to understand the various aspects of solar radiation because:

1. A major part of building heat gain is due to solar radiation, hence an estimate of the amount of solar radiation the building is subjected to is essential for estimating the cooling and heating loads on the buildings.
2. By proper design and orientation of the building, selection of suitable materials and landscaping it is possible to harness solar energy beneficially. This can reduce the overall cost (initial and operating) of the air conditioning system considerably by reducing the required capacity of the cooling and heating equipment.
3. It is possible, at least in certain instances to build heating and cooling systems that require only solar energy as the input. Since solar energy is available and is renewable, use of solar energy for applications such as cooling and heating is highly desirable.

For calculation purposes, the **sun** may be treated as **a radiant energy source with surface temperature** that is approximately equal to that of a blackbody at **6000 K**. The spectrum of wavelength of solar radiation stretches from **0.29  $\mu\text{m}$  to about 4.75  $\mu\text{m}$** , with the peak occurring at about 0.45  $\mu\text{m}$  (the green portion of visible spectrum). Table 32.1 shows spectral distribution of solar radiation with percentage distribution of total energy in various bandwidths.

Type of radiation	Wavelength band ( $\mu\text{m}$ )	% of total radiation
Invisible ultra-violet (UV)	0.29 to 0.40	7
Visible radiation	0.40 to 0.70	39
Near Infrared (IR)	0.70 to 3.50	52
Far infrared (FIR)	4.00 to 4.75	2

**Table 32.1.** Spectral distribution of solar radiation

### 32.2.1. Solar constant:

This is the flux of solar radiation on a surface normal to the sun's rays beyond the earth's atmosphere at the mean earth-sun distance. The currently accepted value of solar constant is  $1370 \text{ W/m}^2$ . Since the earth's orbit is slightly elliptical, the extra-terrestrial radiant flux varies from a maximum of  $1418 \text{ W/m}^2$  on January 3<sup>rd</sup> to a minimum of  $1325 \text{ W/m}^2$  on July 4<sup>th</sup>.

### 32.2.2. Depletion of solar radiation due to earth's atmosphere:

In passing through the earth's atmosphere, which consists of dust particles, various gas molecules and water vapour, the solar radiation gets depleted due to reflection, scattering and absorption. The extent of this depletion at any given time depends on the atmospheric composition and length of travel of sun's rays through the atmosphere. The length of travel is expressed in terms of 'air mass,  $m$ ' which is defined as the ratio of mass of atmosphere in the actual sun-earth path to that which would exist if the sun were directly overhead at sea level. As shown in Fig. 32.1, the air mass is given by:

$$\text{air mass, } m = \frac{\text{length OP}}{\text{length O'P}} = \frac{\sin 90^\circ}{\sin \beta} = \frac{1}{\sin \beta} \quad (32.1)$$

where  $\beta$  is called as altitude angle, which depends on the location, time of the day and day of the year. Thus smaller the altitude angle, larger will be the depletion of radiation.

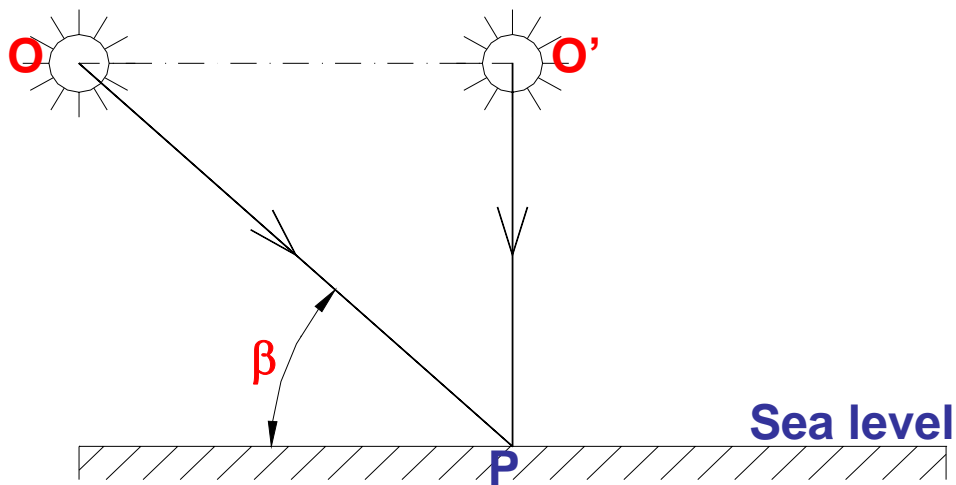
### 32.2.3. Total solar irradiation:

In order to calculate the building heat gain due to solar radiation, one has to know the amount of solar radiation incident on various surfaces of the building. The rate at which solar radiation is striking a surface per unit area of the surface is called as the total solar irradiation on the surface. This is given by:

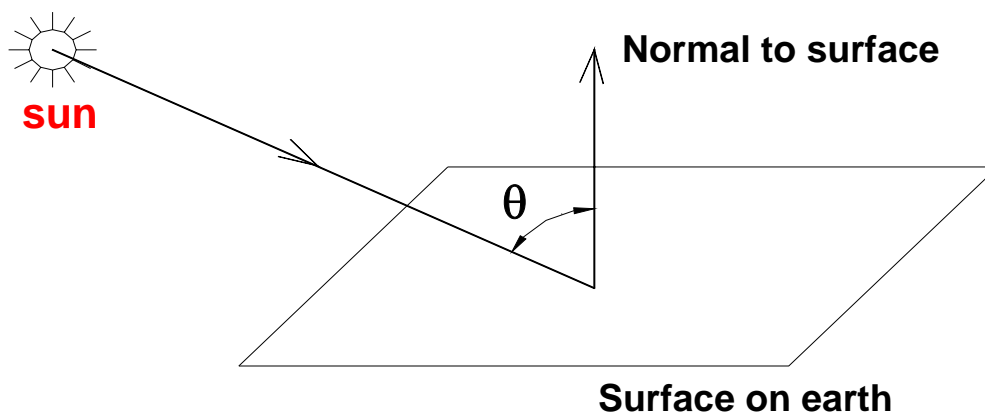
$$I_{i\theta} = I_{DN} \cos \theta + I_{d\theta} + I_{r\theta} \quad (32.2)$$

- where  $I_{i\theta}$  = Total solar irradiation of a surface,  $W/m^2$   
 $I_{DN}$  = Direct radiation from sun,  $W/m^2$   
 $I_{d\theta}$  = Diffuse radiation from sky,  $W/m^2$   
 $I_{r\theta}$  = Short wave radiation reflected from other surfaces,  $W/m^2$   
 $\theta$  = Angle of incidence, degrees (Figure 32.2)

The first term on the RHS, i.e.,  $I_{DN} \cos \theta$ , is the contribution of direct normal radiation to total irradiation. On a clear, cloudless day, it constitutes about 85 percent of the total solar radiation incident on a surface. However, on cloudy days the percentage of diffuse and reflected radiation components is higher. The objective of solar radiation calculations is to estimate the direct, diffuse and reflected radiations incident on a given surface. These radiations and the angle of incidence are affected by solar geometry.



**Fig.32.1:** Depletion of solar radiation due to earth's atmosphere



**Fig.32.2:** Definition of angle of incidence

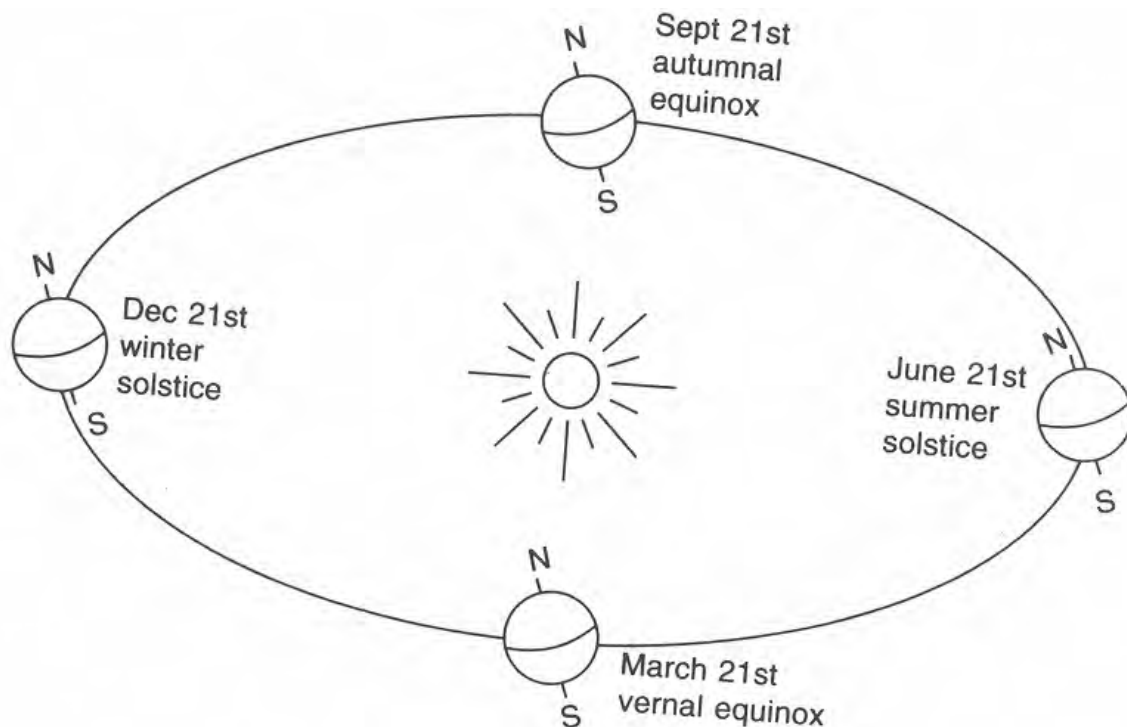
### 32.2.4. Solar geometry:

The angle of incidence  $\theta$  depends upon:

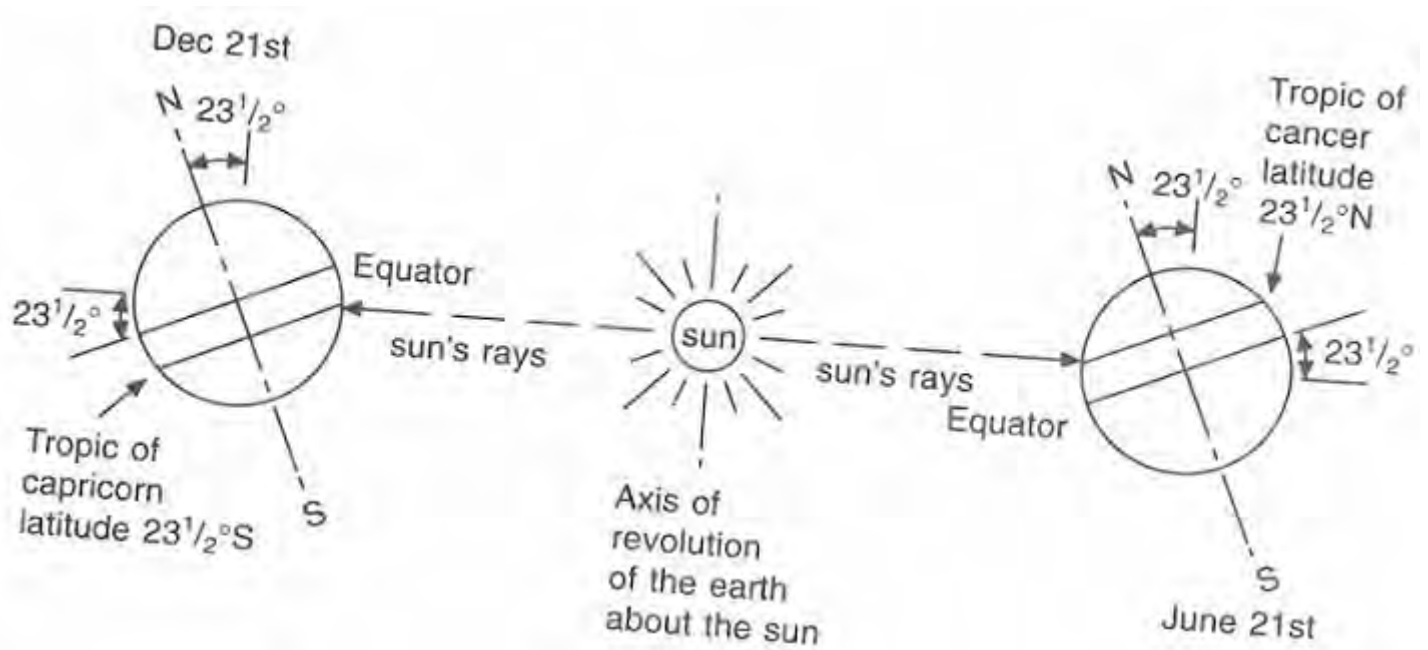
- i. Location on earth
- ii. Time of the day, and
- iii. Day of the year

The above three parameters are defined in terms of **latitude**, **hour angle** and **declination**, respectively.

The planet earth makes one rotation about its axis every 24 hours and one revolution about the sun in a period of about 365 days. The earth's equatorial plane is tilted at an angle of about  $23.5^\circ$  with respect to its orbital plane. The earth's rotation is responsible for day and night, while its tilt is responsible for change of seasons. Figure 32.3 shows the position of the earth at the start of each season as it revolves in its orbit around the sun. As shown in Fig.32.4, during summer solstice (June 21<sup>st</sup>) the sun's rays strike the northern hemisphere more directly than they do the southern hemisphere. As a result, the northern hemisphere experiences summer while the southern hemisphere experiences winter during this time. The reverse happens during winter solstice (December 21<sup>st</sup>).

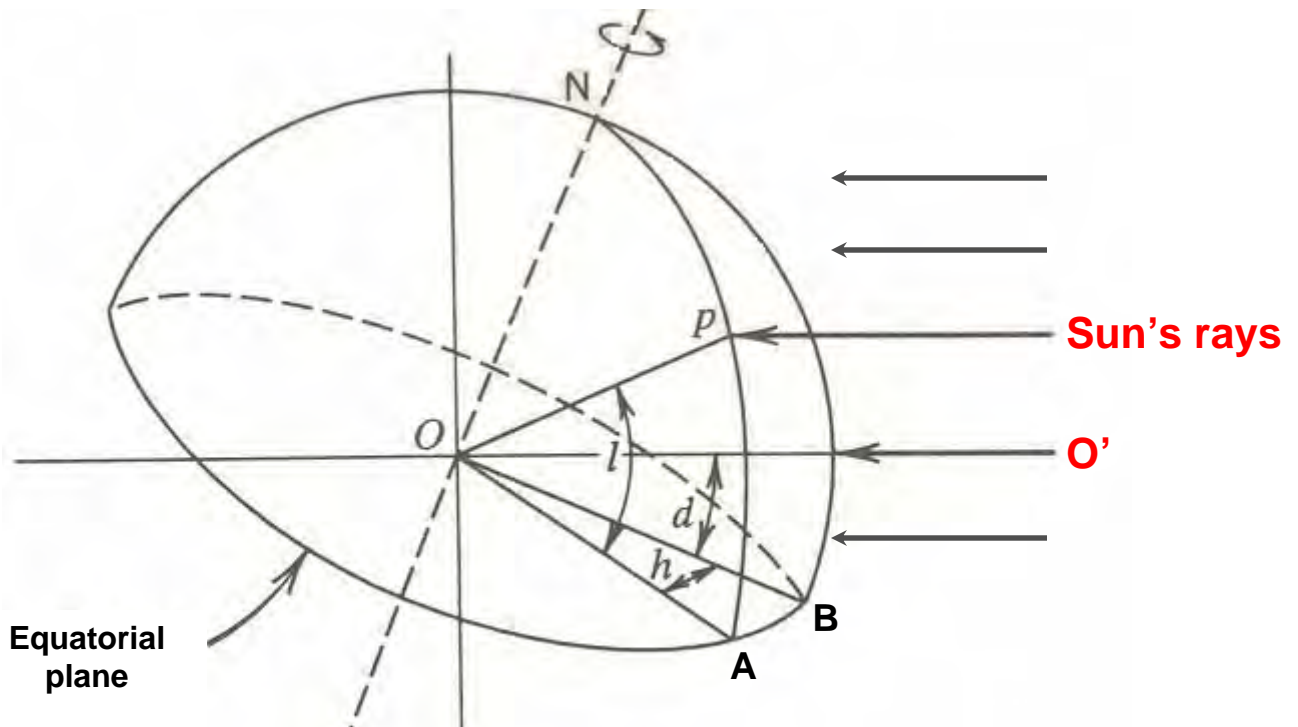


**Fig.32.3:** Position of earth with respect to sun for different seasons



**Fig.32.4:** Direction of sun's rays during summer and winter solstice

Figure 32.5 shows the position of a point P on the northern hemisphere of the earth, whose center is at point O. Since the distance between earth and sun is very large, for all practical purposes it can be considered that the sun's rays are parallel to each other when they reach the earth.



**Fig.32.5:** Definition of latitude ( $l$ ), declination ( $d$ ) and hour angles ( $h$ )



With reference to Fig.32.5, the various solar angles are defined as follows:

**Latitude, I:** It is the angle between the lines joining O and P and the projection of OP on the equatorial plane, i.e.,

$$\text{latitude, } I = \text{angle } \angle POA$$

Thus the latitude along with the longitude indicates the position of any point on earth and it varies from  $0^\circ$  at equator to  $90^\circ$  at the poles.

**Hour angle, h:** It is the angle between the projection of OP on the equatorial plane i.e., the line OA and the projection of the line joining the center of the earth to the center of the sun, i.e., the line OB. Therefore,

$$\text{hour angle, } h = \text{angle } \angle AOB$$

The hour angle is a measure of the time of the day with respect to solar noon. **Solar noon** occurs when the sun is at the highest point in the sky, and hour angles are symmetrical with respect to solar noon. This implies that the **hour angles of sunrise and sunset on any given day are identical**. The hour angle is  $0^\circ$  at solar noon and varies from  $0^\circ$  to  $360^\circ$  in one rotation. Since it takes 24 clock hours for one rotation, each clock hour of time is equal to  $15^\circ$  of hour angle. For example, at 10 A.M. (solar time) the hour angle is  $330^\circ$ , while at 4 P.M. it is  $60^\circ$ .

**Solar time:** Solar radiation calculations such as the hour angle are based on local solar time (LST). Since the earth's orbital velocity varies throughout the year, the local solar time as measured by a sundial varies slightly from the mean time kept by a clock running at uniform rate. A civil day is exactly equal to 24 hours, whereas a solar day is approximately equal to 24 hours. This variation is called as Equation of Time (EOT) and is available as average values for different months of the year. The EOT may be considered as constant for a given day. An approximate equation for calculating EOT given by Spencer (1971) is:

$$\text{EOT} = 0.2292(0.075 + 1.868 \cos N - 32.077 \sin N - 4.615 \cos 2N - 40.89 \sin 2N) \quad (32.3)$$

where  $N = (n - 1) \left( \frac{360}{365} \right)$ ; n is the day of the year (counted from January 1<sup>st</sup>)

At any location, the local solar time is given by:

$$\text{LST} = \text{LStT} + \text{EOT} + 4(\text{LON} - \text{LSM}) \quad (32.4)$$

in the above equation LStT is the local standard time, LSM is the local standard time meridian and LON is the local longitude. In the above equation '+' sign is

used if LON is to the east of LSM and '-' sign should be used if LON is to the west of LSM.

**Declination, d:** The declination is the angle between the line joining the center of the earth and sun and its projection on the equatorial plane, the angle between line OO' and line OB;

$$\text{declination, } d = \text{angle } \angle O'OB$$

For northern hemisphere, the declination varies from about +23.5° on June 21<sup>st</sup> (summer solstice) to -23.5° on December 21<sup>st</sup> (December 21<sup>st</sup>). At equinoxes, i.e., on March 21<sup>st</sup> and September 21<sup>st</sup> the declination is 0° for northern hemisphere. The declination varies approximately in a sinusoidal form, and on any particular day the declination can be calculated approximately using the following equation:

$$\text{declination, } d = 23.47 \sin \frac{360(284 + N)}{365} \quad (32.5)$$

where N is the day of the year numbered from January 1<sup>st</sup>. Thus on March 6<sup>th</sup>, N is 65 (65<sup>th</sup> day of the year) and from the above equation, declination on March 6<sup>th</sup> is equal to -6.4°.

### 32.2.5. Derived solar angles:

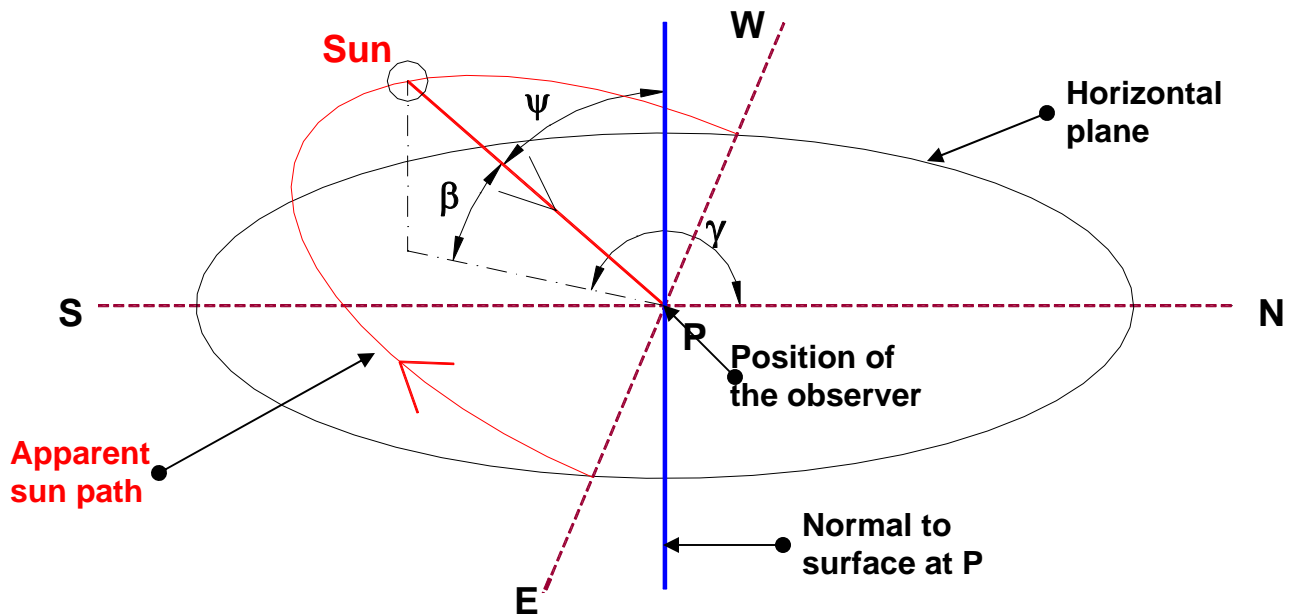
In addition to the three basic solar angles, i.e., the latitude, hour angle and declination, several other angles have been defined (in terms of the basic angles), which are required in the solar radiation calculations. Figure 32.6 shows a schematic of one apparent solar path and defines the **altitude angle** ( $\beta$ ), **zenith angle** ( $\psi$ ) and **solar azimuth angle** ( $\gamma$ ). It can be shown by analytical geometry that these angles are given by:

**Altitude angle,  $\beta$ :** It is the angle between the sun's rays and the projection of sun's rays onto a horizontal plane as shown in Fig.32.6. The expression for altitude angle is given by:

$$\text{Altitude angle, } \beta = \sin^{-1}(\cos l \cdot \cos h \cdot \cos d + \sin l \cdot \sin d) \quad (32.6)$$

**Zenith angle,  $\psi$ :** It is the angle between sun's rays and the surface normal to the horizontal plane at the position of the observer. It can be seen from Fig.32.6 that:

$$\text{Zenith angle, } \psi = \frac{\pi}{2} - \beta \quad (32.7)$$



**Fig.32.6:** Definition of altitude angle, zenith angle and solar azimuth angle

The altitude angle  $\beta$  is maximum at solar noon. Since the hour angle,  $h$  is  $0^\circ$  at solar noon, the maximum altitude angle  $\beta_{\max}$  (solar noon) on any particular day for any particular location is given by substituting the value of  $h = 0^\circ$  in the expression for  $\beta$  given above (Eqn.(32.6)), thus it can be easily shown that:

$$\beta_{\max} = \frac{\pi}{2} - |l - d| \quad (32.8)$$

where  $|l - d|$  is the absolute value of  $(l-d)$ .

The equation for altitude angle can also be used for finding the time of sunrise, sunset and sunshine hours as the altitude angle is  $0^\circ$  at both sunrise and sunset (Fig.32.6). Thus from the equation for  $\beta$ , at sunrise and sunset  $\beta = 0$ , hence the hour angle at sunrise and sunset is given by:

$$h_o = \cos^{-1}(-\tan l \cdot \tan d) \quad (32.9)$$

From the hour angle one can calculate the sunrise, sunset and total sunshine hours as the sunrise and sunset are symmetrical about the solar noon.

**Solar azimuth angle,  $\gamma$ :** As shown in Fig.32.6, the solar azimuth angle is the angle in the horizontal plane measured from north to the horizontal projection of the sun's rays. It can be shown that the solar azimuth angle is given by:

$$\gamma = \cos^{-1} \left( \frac{\cos l \cdot \sin d - \cos d \cdot \cos h \cdot \sin l}{\cos \beta} \right) = \sin^{-1} \left( \frac{\cos d \cdot \sin h}{\cos \beta} \right) \quad (32.10)$$

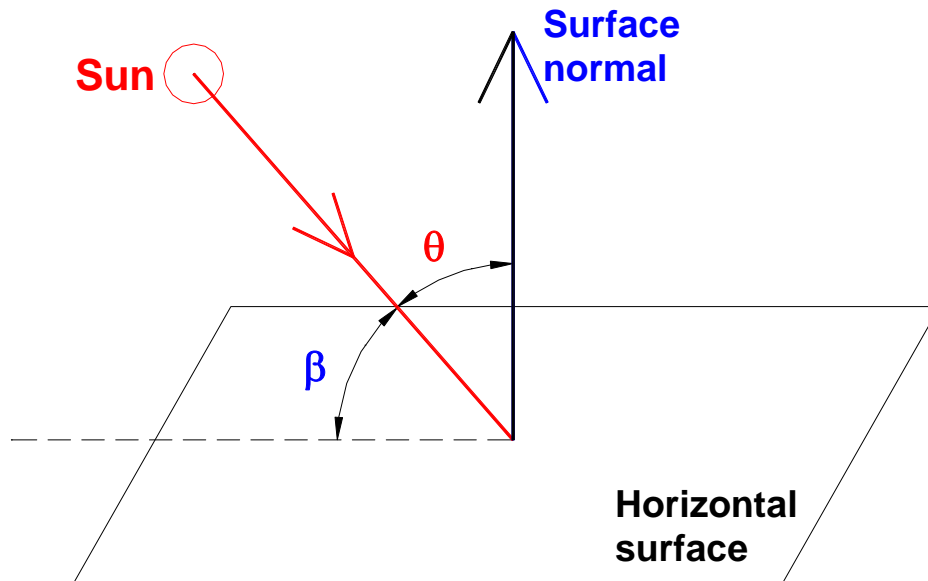
At solar noon when the hour angle is zero, the solar azimuth angle is equal to  $180^\circ$ , if the latitude,  $l$  is greater than declination,  $d$ , and it is equal to  $0^\circ$  if  $l < d$ . The solar azimuth angle at solar noon is not defined for  $l = d$ .

### 32.2.6. Incident angle of sun's rays, $\theta$ :

The incident angle of sun's rays  $\theta$ , is the angle between sun's rays and the normal to the surface under consideration. The angle of incidence depends on the solar geometry and also the orientation of the surface.

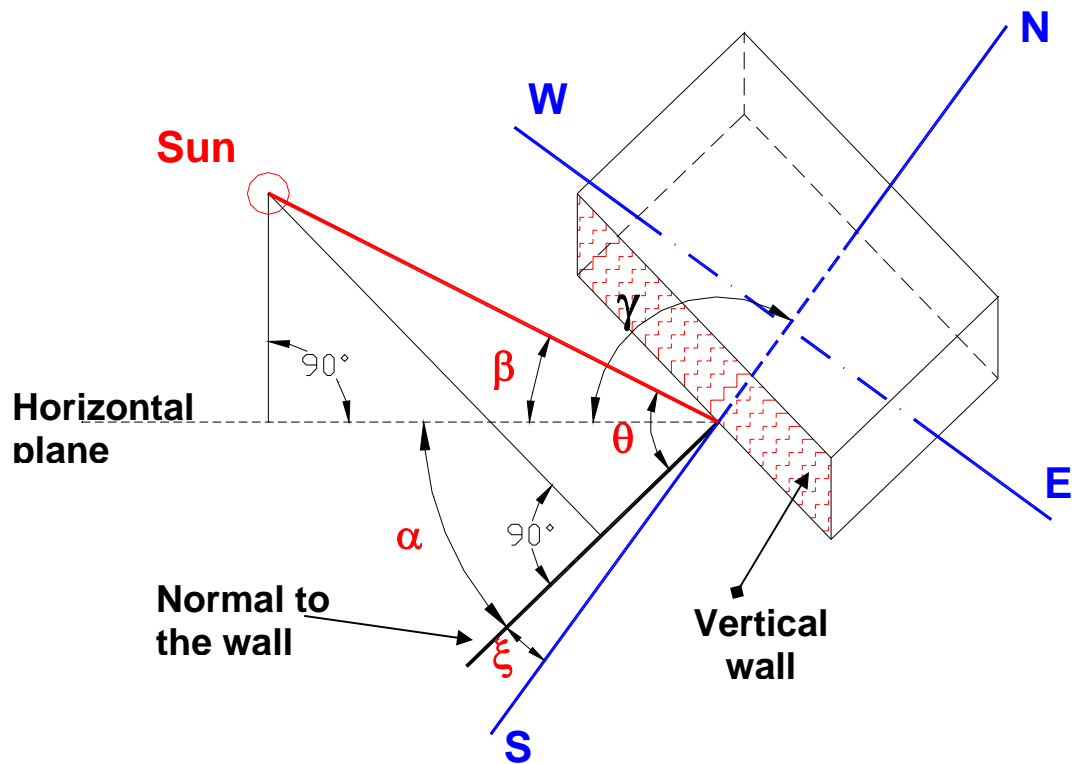
**For horizontal surfaces:** For horizontal surfaces (Fig.32.7) the angle of incidence  $\theta_{\text{hor}}$  is equal to the zenith angle,  $\psi$ , i.e.,

$$\theta_{\text{hor}} = \psi = \frac{\pi}{2} - \beta \quad (32.11)$$



**Fig.32.7:** Incident angle for a horizontal surface

**For vertical surfaces:** Figure 32.8 shows an arbitrarily orientated vertical surface (shaded) that is exposed to solar radiation. The angle of incidence of solar radiation on the vertical surface depends upon the orientation of the wall, i.e, east facing, west facing etc. Additional angles have to be defined to find the angle of incidence on the vertical walls.



**Fig.32.8:** Calculation of incident solar angle for vertical surfaces

Referring to Fig.32.8, the following additional angles are defined:

**Wall solar azimuth angle,  $\alpha$ :** This is the angle between normal to the wall and the projection of sun's rays on to a horizontal plane.

**Surface azimuth angle,  $\xi$ :** This is the angle between the normal to the wall and south. Thus when the wall is facing south, then the surface azimuth angle is zero and when it faces west, then the surface azimuth angle is  $90^\circ$  and so on. **The angle is taken as +ve if the normal to the surface is to the west of south and -ve if it is to the east of south.**

From Fig.32.8 it can be seen that the wall solar azimuth angle, is given by:

$$\alpha = [\pi - (\gamma + \xi)]F \quad (32.12)$$

The factor F is -1 for forenoon and +1 for afternoon.

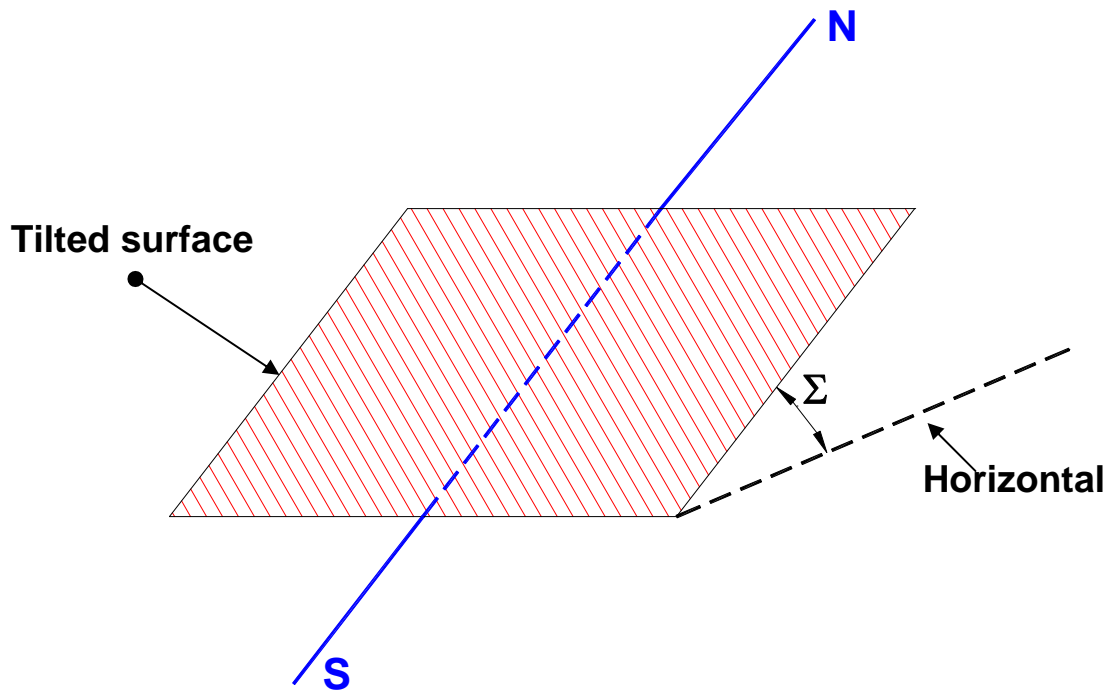
Now it can be shown that the angle of incidence on the vertical surface,  $\theta_{\text{ver}}$  is given by:

$$\theta_{\text{ver}} = \cos^{-1}(\cos \beta \cdot \cos \alpha) \quad (32.13)$$

**For an arbitrarily oriented surfaces:** For any surface that is tilted at an angle  $\Sigma$  from the horizontal as shown in Fig.32.9, the incident angle  $\theta$  is given by:

$$\theta = \cos^{-1}(\sin \beta \cdot \cos \Sigma + \cos \beta \cdot \cos \alpha \cdot \sin \Sigma) \quad (32.14)$$

This equation is a general equation and can be used for any arbitrarily oriented surface. For example, for a horizontal surface,  $\Sigma$  is  $0^\circ$ , hence  $\theta_{\text{hor}}$  is equal to  $(90 - \beta)$ , as shown earlier. Similarly, for a vertical surface,  $\Sigma$  is  $90^\circ$ , hence  $\theta_{\text{ver}}$  is equal to  $\cos^{-1}(\cos \beta \cdot \cos \alpha)$ , as shown before.



*Fig.32.9: An arbitrarily oriented surface with a tilt angle  $\Sigma$*

### 32.3. Calculation of direct, diffuse and reflected radiations:

#### 32.3.1. Direct radiation from sun ( $I_{\text{DN}}$ ):

Several solar radiation models are available for calculation of direct radiation from sun. One of the commonly used models for air conditioning calculations is the one suggested by ASHRAE. According to this model, the direct radiation  $I_{\text{DN}}$  is given by:

$$I_{\text{DN}} = A \cdot \exp\left(-\frac{B}{\sin \beta}\right) \quad (\text{W/m}^2) \quad (32.15)$$

where A is the apparent solar irradiation which is taken as 1230 W/m<sup>2</sup> for the months of December and January and 1080 W/m<sup>2</sup> for mid-summer. Constant B is called as atmospheric extinction coefficient, which takes a value of 0.14 in winter and 0.21 in summer. The values of A and B for 21<sup>st</sup> day of each month have been computed are available either in the form of tables or empirical equations.

### 32.3.2. Diffuse radiation from sky, I<sub>d</sub>:

According to the ASHRAE model, the diffuse radiation from a cloudless sky is given by:

$$I_d = C \cdot I_{DN} \cdot F_{WS} \quad (\text{W/m}^2) \quad (32.16)$$

The value of C is assumed to be constant for a cloudless sky for an average day of a month. Its average monthly values have been computed and are available in tabular form. The value of C can be taken as 0.135 for mid-summer and as 0.058 for winter. The factor F<sub>WS</sub> is called as **view factor or configuration factor** and is equal to the fraction of the diffuse radiation that is incident on the surface. For diffuse radiation, F<sub>WS</sub> is a function of the orientation of the surface only. It can be easily shown that this is equal to:

$$F_{WS} = \frac{(1 + \cos \Sigma)}{2} \quad (32.17)$$

where  $\Sigma$  is the tilt angle. Obviously for horizontal surfaces ( $\Sigma = 0^\circ$ ) the factor F<sub>WS</sub> is equal to 1, whereas it is equal to 0.5 for a vertical surface ( $\Sigma = 90^\circ$ ). The above model is strictly true for a cloudless sky only as it assumes that the diffuse radiation from the sky falls uniformly on the surface. The diffuse radiation will not be uniform when the sky is cloudy.

### 32.3.3. Reflected, short-wave (solar) radiation, I<sub>r</sub>:

The amount of solar radiation reflected from the ground onto a surface is given by:

$$I_r = (I_{DN} + I_d) \rho_g F_{WG} \quad (32.18)$$

where  $\rho_g$  is the reflectivity of the ground or a horizontal surface from where the solar radiation is reflected on to a given surface and F<sub>WG</sub> is view factor from ground to the surface. The value of reflectivity obviously depends on the surface property of the ground. The value of the angle factor F<sub>WG</sub> in terms of the tilt angle is given by:

$$F_{WG} = \frac{(1 - \cos \Sigma)}{2} \quad (32.19)$$

Thus for horizontal surfaces ( $\Sigma = 0^\circ$ ) the factor  $F_{WG}$  is equal to 0, whereas it is equal to 0.5 for a vertical surface ( $\Sigma = 90^\circ$ ).

Though the ASHRAE clear sky model is widely used for solar radiation calculations in air conditioning, more accurate, but more involved models have also been proposed for various solar energy applications.

**Example:** Calculate the total solar radiation incident on a south facing, vertical surface at solar noon on June 21<sup>st</sup> and December 21<sup>st</sup> using the data given below:

Latitude =  $23^\circ$   
 Reflectivity of the ground = 0.6  
 Assume the sky to be cloudless

**Ans.:**

Given: Latitude angle,  $l = 23^\circ$   
 Hour angle,  $h = 0^\circ$  (solar noon)  
 Declination,  $d = +23.5^\circ$  (on June 21<sup>st</sup>)  
 $= -23.5^\circ$  (on December 21<sup>st</sup>)  
 Tilt angle,  $\Sigma = 90^\circ$  (Vertical surface)  
 Wall azimuth angle,  $\xi = 0^\circ$  (south facing)  
 Reflectivity,  $\rho_g = 0.6$

**June 21<sup>st</sup> :**

$$\text{Altitude angle } \beta \text{ at solar noon } \beta_{\max} = \frac{\pi}{2} - |l - d| = 89.53^\circ$$

At solar noon, solar azimuth angle,  $\gamma = 0^\circ$  as  $l < d$

$$\therefore \text{wall solar azimuth angle, } \alpha = 180 - (\gamma + \xi) = 180^\circ$$

$$\text{Incidence angle } \theta_{\text{ver}} = \cos^{-1}(\cos \beta \cdot \cos \alpha) = 89.53^\circ$$

Direct radiation,  $I_{DN} \cos(\theta)$ :

$$I_{DN} = A \cdot \exp\left(-\frac{B}{\sin \beta}\right) = 1080 \cdot \exp\left(-\frac{0.21}{\sin 89.3}\right) = 875.4 \text{ W/m}^2$$

$$I_{DN} \cos \theta = 875.4 \times \cos 89.53 = 7.18 \text{ W/m}^2$$

Diffuse radiation,  $I_d$ :

$$\text{View factor } F_{WS} = \frac{(1 + \cos \Sigma)}{2} = 0.5$$

$$\text{Diffuse radiation } I_d = C \cdot I_{DN} \cdot F_{WS} = 0.135 \times 875.4 \times 0.5 = 59.1 \text{ W/m}^2$$



Reflected radiation from ground ( $\rho_g = 0.6$ ),  $I_d$ :

$$\text{View factor } F_{WG} = \frac{(1 - \cos \Sigma)}{2} = 0.5$$

Reflected radiation,  $I_r$ :

$$I_r = (I_{DN} + I_d)\rho_g F_{WG} = (875.43 + 59.1) \times 0.6 \times 0.5 = 280.36 \text{ W/m}^2$$

$$\therefore \text{total incident radiation } I_t = I_{DN} \cos \theta + I_d + I_r = 346.64 \text{ W/m}^2$$

Calculations similar to the can be carried out for December 21<sup>st</sup> (declination is  $-23.5^\circ$ ) . Table 35.2 shows a comparison between the solar radiation on the south facing wall during summer (June 21<sup>st</sup>) and winter (December 21<sup>st</sup>):

Parameter	June 21 <sup>st</sup>	December 21 <sup>st</sup>
Incident angle, $\theta$	89.53°	43.53°
Direct radiation, $I_{DN}$	875.4 W/m <sup>2</sup>	1003.75 W/m <sup>2</sup>
Direct radiation incident on the wall, $I_{DNCOS} \theta$	7.18 W/m <sup>2</sup>	727.7 W/m <sup>2</sup>
Diffuse radiation, $I_d$	59.1 W/m <sup>2</sup>	29.1 W/m <sup>2</sup>
Reflected radiation, $I_r$	280.36 W/m <sup>2</sup>	309.9 W/m <sup>2</sup>
Total incident radiation, $I_t$	346.64 W/m <sup>2</sup>	1066.7 W/m <sup>2</sup>

The above table reveals an interesting fact. It is seen that in northern hemisphere, a wall facing south receives much less radiation in summer compared to winter. This is mainly due to the value of incident angle, which is much larger in summer compared to winter for a south facing wall. This reduces the contribution of the direct radiation significantly in summer compared to winter. In fact if the ground has lower reflectivity than the value used in the example (0.6), then the radiation incident on the vertical wall in summer will be almost negligible, while it will be still very high in winter. This implies that from air conditioning point of view, buildings in northern hemisphere should have windows on the south facing wall so that the cooling load in summer and heating load in winter reduces considerably.

### 32.4. Effect of clouds:

It is mentioned earlier that on a clear day, almost 85% of the incident radiation is due to direct radiation and the contribution of diffuse radiation is much smaller. However, when the sky is cloudy, the contribution of diffuse radiation increases significantly. Though it is frequently assumed that the diffuse radiation from the sky reaches the earth uniformly on clear days, studies show that this is far from true. The diffuse radiation is even more non-uniform on cloudy days. Due to the presence of the clouds (which is extremely difficult to predict), the available solar radiation in an actual situation is highly variable. Clouds not only block the short-wave radiation from the sun, but they also block the long-wave radiation from earth. Thus it is very difficult to accurately account for the effect of clouds on solar and terrestrial radiation. Sometimes, in solar energy calculations a **clearness index** is used to take into account the effect of clouds. Arbitrarily a value of 1.0 is assigned for clearness index for a perfectly clear and cloudless sky. A clearness index value of less than 1.0 indicates the presence of clouds. The calculations are carried out for a clear sky and the resulting direct radiation is multiplied by the clearness index to calculate the contribution of direct radiation in the presence of clouds. Data on the value of the clearness index are available for a few select countries.

### Questions and answers:

1. Calculate the local solar time and the corresponding hour angle at 9 A.M (local standard time, L.St.T) on October 21<sup>st</sup>, for the Indian city of Kolkata located at 22°82'N and 88°20'E, the LSM for India is 82°30'. the EOT for Kolkata on October 21<sup>st</sup> is 15 minutes.

**Ans.:** Local solar time, LST is given by the expression,

$$\text{LST} = \text{LStT} + 15 + 4(88.33 - 82.5) = \mathbf{9 \text{ hours } 38.32 \text{ minutes A.M.}} \quad (\text{Ans.})$$

$$\mathbf{\text{the corresponding hour angle is } 324.6^\circ} \quad (\text{Ans.})$$

2. Find the maximum altitude angle for Kolkata ( $l = 22^\circ 82' \text{N}$ ) on June 21<sup>st</sup>.

**Ans.:** On June 21<sup>st</sup>, the declination angle,  $d$  is  $\mathbf{23.5^\circ}$ .

The maximum altitude angle occurs at solar noon at which the hour angle is zero. Hence, Maximum altitude angle,  $\beta_{\max}$  is given by:

$$\beta_{\max} = \frac{\pi}{2} - |(l - d)| = \mathbf{90 - (22.82 - 23.5) = 89.3^\circ} \quad (\text{Ans.})$$

3. Find the sunrise, sunset and total sunshine hours at IIT Kharagpur ( $\approx 22^\circ\text{N}$ ) on September 9<sup>th</sup>.

**Ans.:** On September 9<sup>th</sup>,  $N = 252$ , hence the declination,  $d$  is equal to  $4.62^\circ$ .

The hour angle at sunrise and sunset is given by,

$$h_o = \cos^{-1}(-\tan 22 \cdot \tan 4.62) = 91.87^\circ$$

Since each  $15^\circ$  is equal to 1 hour,  $91.87^\circ$  is equal to 6 hours and 8 minutes. Hence,

Sunrise takes place at  $(12.00 - 6.08) = 5.52 \text{ A.M (solar time)}$  (Ans.)

Sunset takes place at  $(12.00 + 6.08) = 6.08 \text{ P.M. (solar time)}$

Total sunshine hours are  $2 \times 6.08 = 12 \text{ hours and 16 minutes}$

4. What is the angle of incidence at 3 P.M. (solar time) of a north-facing roof that is tilted at an angle of  $15^\circ$  with respect to the horizontal. Location:  $22^\circ\text{N}$ , and date September 9<sup>th</sup>.

**Ans.:** Given: Latitude,  $I = 22^\circ$  (N)

Solar time = 3 P.M.  $\Rightarrow$  hour angle,  $h = 45^\circ$

Date = September 9<sup>th</sup>  $\Rightarrow$  declination,  $d = 4.62^\circ$  (from earlier example)

**Altitude angle,  $\beta = \sin^{-1}(\cos I \cdot \cos d \cdot \cos h + \sin I \cdot \sin d) = 43.13^\circ$**

Since the roof is north facing, the surface azimuth angle  $\xi$  is equal to  $180^\circ$ .

The solar azimuth angle  $\gamma$  is given by:

$$\gamma = \sin^{-1}\left(\frac{\cos d \cdot \sin h}{\cos \beta}\right) = \sin^{-1}\left(\frac{\cos 4.62 \sin 45}{\cos 43.13}\right) = 74.96^\circ$$

The wall solar azimuth angle  $\alpha = 180 - (\gamma + \xi) = 180 - (74.96 - 180) = 285^\circ$

Hence the angle of incidence is

$$\theta = \cos^{-1}(\sin 43.13 \cos 15 - \cos 43.13 \cdot \cos 285 \cdot \sin 15) = 52.3^\circ$$

5. Find the direct normal radiation at Kolkata on June 21<sup>st</sup> at solar noon?

**Ans.:** From the earlier example, on June 21<sup>st</sup> at solar noon, the altitude angle for Kolkata is 89.3°. Hence the direct solar radiation is given by:

$$I_{DN} = A \cdot \exp\left(-\frac{B}{\sin \beta}\right) = 1080 \cdot \exp\left(-\frac{0.21}{\sin 89.3}\right) = 875.4 \text{ W/m}^2 \text{ (Ans.)}$$

6. Find the diffuse and total solar radiation incident on a horizontal surface located at Kolkata on June 21<sup>st</sup> at solar noon?

**Ans.:** From the earlier example, on June 21<sup>st</sup> at solar noon, the direct solar radiation is equal to **875.4 W/m<sup>2</sup>**. Since the surface is horizontal, the view factor for diffuse radiation,  $F_{WS}$  is equal to 1, whereas it is 0 for reflected radiation.

Hence, the diffuse solar radiation is given by:

$$I_d = C \cdot I_{DN} \cdot F_{WS} = 0.135 \times 875.4 = 118.18 \text{ W/m}^2 \quad \text{(Ans.)}$$

Since the surface is horizontal, the reflected solar radiation is zero. The angle of incidence, is given by:

$$\theta_{hor} = (90 - \beta_{noon}) = 90 - 89.3 = 0.7^\circ$$

Hence the total incident solar radiation is given by:

$$I_t = I_{DN} \cdot \cos(\theta) + I_d = 875.4 \times \cos(0.7) + 118.18 = 993.5 \text{ W/m}^2 \quad \text{(Ans.)}$$

# Lesson

33

Cooling And Heating

Load Calculations

-Solar Radiation

Through Fenestration

- Ventilation And

Infiltration

## The specific objectives of this lesson are to discuss:

1. Need for fenestration in buildings and effects of fenestration on air conditioning systems (*Section 33.1*)
2. Estimation of heat transfer rate into buildings through fenestration, concepts of Solar Heat Gain Factor (SHGF) and Shading Coefficient (*Section 33.2*)
3. Effect of external shading, calculation of shaded area of fenestrations, estimation of heat transfer rate through windows with overhangs (*Section 33.3*)
4. Need for ventilation and recommended ventilation rates (*Section 33.4*)
5. Infiltration and causes for infiltration (*Section 33.5*)
6. Estimation of heat transfer rate due to infiltration and ventilation (*Section 33.6*)

At the end of the lecture, the student should be able to:

1. Define fenestration and explain the need for fenestration and its effect on air conditioning
2. Calculate heat transfer rate due to fenestration using SHGF tables and shading coefficients
3. Calculate the dimensions of shadow cast on windows with overhangs and estimate the heat transfer rate through shaded windows
4. Explain the need for ventilation and select suitable ventilation rates
5. Define infiltration and explain the causes for infiltration
6. Calculate the heat transfer rates due to infiltration and ventilation

### 33.1. Solar radiation through fenestration:

Fenestration refers to any glazed (transparent) apertures in a building, such as glass doors, windows, skylights etc. Fenestration is required in a building as it provides:

- a) Daylight, heat and outside air
- b) Visual communication to the outside world
- c) Aesthetics, and
- d) Escape route in case of fires in low-rise buildings

Because of their transparency, fenestrations transmit solar radiation into the building. Heat transfer through transparent surfaces is distinctly different from heat transfer through opaque surfaces. When solar radiation is incident on an opaque building wall, a part of it is absorbed while the remaining part is reflected back. As will be shown later, only a fraction of the radiation absorbed by the opaque surface is transferred to the interiors of the building. However, in case of transparent surfaces, a major portion of the solar radiation is transmitted directly to the interiors of the building, while the remaining small fraction is absorbed and/or reflected back. Thus the fenestration or glazed surfaces contribute a major part of cooling load of a building. The energy transfer due to fenestration depends on the characteristics of the surface and its orientation, weather and solar radiation conditions. A careful design of fenestration can reduce the building energy consumption considerably.

### 33.2. Estimation of solar radiation through fenestration:

Figure 33.1 shows an **unshaded window** made of **clear plastic glass**. As shown in the figure, the properties of this glass for solar radiation are: **transmittivity ( $\tau$ ) = 0.80**, **reflectivity ( $\rho$ ) = 0.08** and **absorptivity ( $\alpha$ ) = 0.12**. Thus out of 100% of solar radiation incident on the glass, 80% is directly transmitted to the indoors, 12% is absorbed by the glass (**which increases the temperature of the glass**) and the remaining 8% is reflected back. Of the 12% absorbed by the glass which leads to increase in its temperature, about 4% is transferred to the indoors by convection heat transfer and the remaining 8% is lost to the outdoors by convection and radiation. Thus out of 100% radiation, 84% is transmitted to the interiors of the building. Of course, these figures are for a clear plate glass only. For other types of glass, the values will be different.

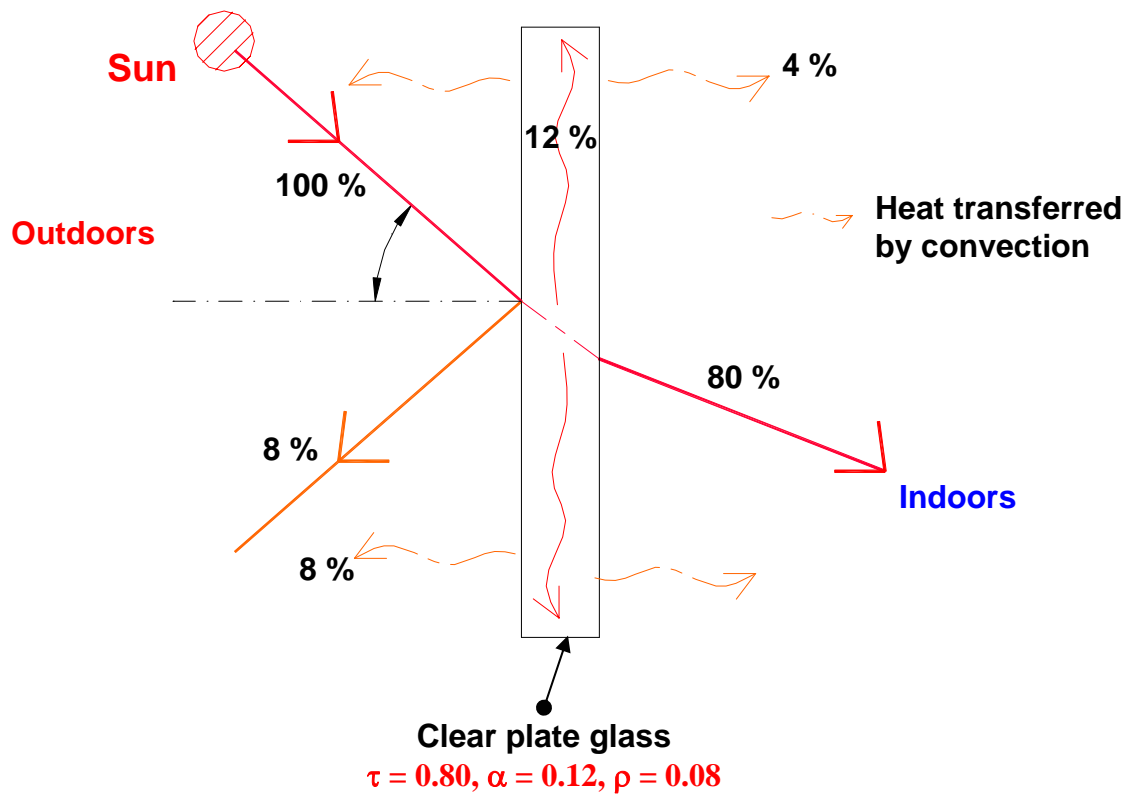
Assuming the transmittivity and absorptivity of the surface same for direct, diffuse and reflected components of solar radiation, the amount of solar radiation passing through a transparent surface can be written as:

$$Q_{sg} = A(\tau \cdot I_t + N \cdot \alpha \cdot I_t) \quad (33.1)$$

where:

- A = Area of the surface exposed to radiation
- $I_t$  = Total radiation incident on the surface
- $\tau$  = Transmittivity of glass for direct, diffuse and reflected radiations
- $\alpha$  = Absorptivity of glass for direct, diffuse and reflected radiations

N = Fraction of absorbed radiation transferred to the indoors by conduction and convection



**Fig.33.1:** Radiation properties of clear plate glass

In the above equation, the total incident radiation consists of direct, diffuse and reflected radiation, and it is assumed that the values of transmittivity and absorptivity are same for all the three types of radiation. Under steady state conditions it can be shown that the fraction of absorbed radiation transferred to the indoors, i.e., N is equal to:

$$N = \frac{U}{h_o} \quad (33.2)$$

where U is the overall heat transfer coefficient, which takes into account the external heat transfer coefficient, the conduction resistance offered by the glass and the internal heat transfer coefficient, and  $h_o$  is the external heat transfer coefficient.

From the above two equations, we can write:

$$Q_{sg} = A \left[ I_t \left( \tau + \frac{\alpha U}{h_o} \right) \right] \quad (33.3)$$



The term in square brackets for a single sheet, clear window glass (reference) is called as **Solar Heat Gain Factor (SHGF)**, i.e.,

$$\text{SHGF} = \left[ I_t \left( \tau + \frac{\alpha U}{h_o} \right) \right]_{ss} \quad (33.4)$$

Thus SHGF is the heat flux due to solar radiation through the reference glass (SS). The maximum SHGF values for different latitudes, months and orientations have been obtained and are available in the form of Tables in ASHRAE handbooks. For example, Table 33.1 taken from ASHRAE Fundamentals shows the maximum SHGF values in  $\text{W/m}^2$  for  $32^\circ$  N latitude for different months and orientations (direction a glass is facing).

Month	Orientation of the surface					
	N/shade	NE/NW	E/W	SE/SW	S	Horizontal
December	69	69	510	775	795	500
Jan, Nov	75	90	550	785	775	555
Feb, Oct	85	205	645	780	700	685
Mar, Sept	100	330	695	700	545	780
April, Aug	115	450	700	580	355	845
May, July	120	530	685	480	230	865
June	140	555	675	440	190	870

**Table 33.1:** Maximum SHGF factor for sunlit glass located at  $32^\circ$ N ( $\text{W/m}^2$ )

The first column in the table gives the maximum SHGF values of a **north facing glass or a glass shaded from solar radiation and oriented in any direction**. Again it can be observed that, a glass facing south is desirable from cooling and heating loads points of view as it allows maximum heat transfer in winter (reduces required heating capacity) and minimum heat transfer in summer (reduces required cooling capacity). Similar tables are available for other latitudes also in ASHRAE Handbooks.

For fenestrations other than the reference SS glass, a **Shading Coefficient (SC)** is defined such that the heat transfer due to solar radiation is given by:

$$Q_{sg} = A \cdot (\text{SHGF}_{\max}) \cdot (\text{SC}) \quad (33.5)$$

The shading coefficient depends upon the type of the glass and the type of internal shading devices. Typical values of SC for different types of glass with

different types of internal shading devices have been measured and are tabulated in ASHRAE Handbooks. Table 33.2 taken from ASHRAE Fundamentals shows typical values of shading coefficients.

Type of glass	Shading Coefficient, SC					
	Thickness mm	No internal shading	Venetian blinds		Roller shades	
			Medium	Light	Dark	Light
<u>Single glass</u> Regular	3	1.00	0.64	0.55	0.59	0.25
<u>Single glass</u> Plate	6-12	0.95	0.64	0.55	0.59	0.25
<u>Single glass</u> Heat absorbing	6	0.70	0.57	0.53	0.40	0.30
<u>Double glass</u> Regular	3	0.90	0.57	0.51	0.60	0.25
<u>Double glass</u> Plate	6	0.83	0.57	0.51	0.60	0.25
<u>Double glass</u> Reflective	6	0.2-0.4	0.2-0.33	-	-	-

**Table 33.2:** Shading coefficients for different types of glass and internal shading

It can be inferred from the above table that the heat transferred through the glass due to solar radiation can be reduced considerably using suitable internal shadings, however, this will also reduce the amount of sunlight entering into the interior space. Values of SC for different types of curtains have also been evaluated and are available in ASHRAE handbooks. Thus from the type of the sunlit glass, its location and orientation and the type of internal shading one can calculate the maximum heat transfer rate due to solar radiation.

### 33.3. Effect of external shading:

The solar radiation incident on a glazed window can be reduced considerably by using external shadings. The external shading reduces the area of the window exposed to solar radiation, and thereby reduces the heat transmission into the building. A very common method of providing external shading is to use overhangs. The principle of overhangs for solar heat gain control is known for thousands of years. Fixed overhangs are among the simplest, yet an effective method to control the solar heat gain into a building. By proper design of the overhangs it is possible to block the solar radiation during summer and allow it into the building during winter.

Figure 33.2 shows an inset window of height  $H$ , width  $W$  and depth of the inset  $d$ . Without overhang, the area exposed to solar radiation is  $H \times W$ , however, with overhang the area exposed is only  $x \times y$ . The hatched portion in the figure shows the area that is under shade, and hence is not experiencing any direct solar radiation. Thus the solar radiation transmitted into the building with overhang is given by:

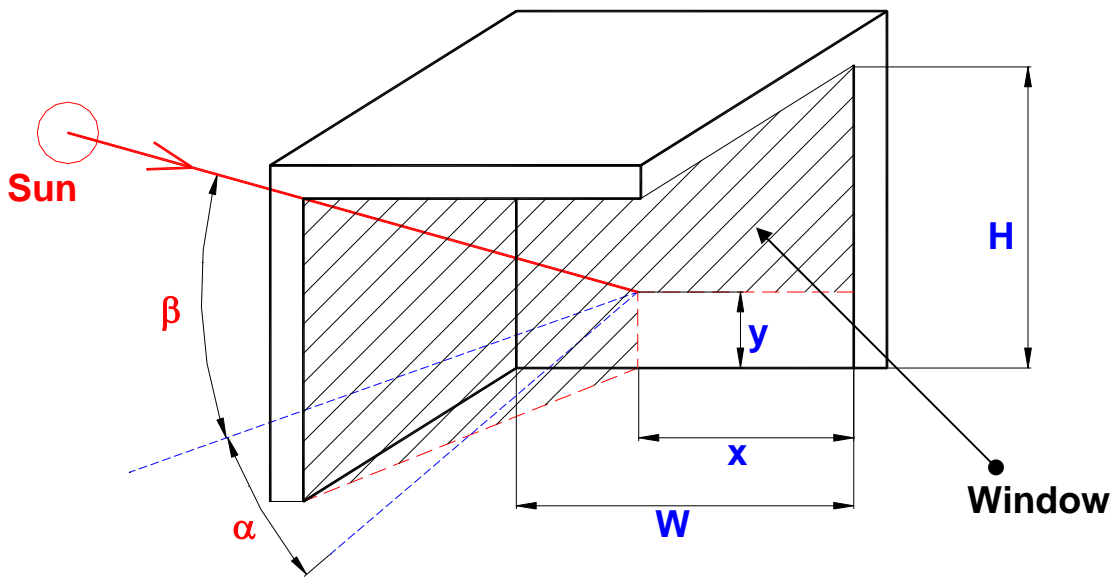
$$Q_{sg} = A_{\text{unshaded}} \cdot (\text{SHGF}_{\text{max}}) \cdot (\text{SC}) = (x \cdot y) \cdot (\text{SHGF}_{\text{max}}) \cdot \text{SC} \quad (33.6)$$

Using solar geometry the area of the window that is not shaded at any location at a particular instant can be calculated. It can be shown that  $x$  and  $y$  are given by:

$$x = W - d(\tan \alpha) \quad (33.7)$$

$$y = H - d \left( \frac{\tan \beta}{\cos \alpha} \right) \quad (33.8)$$

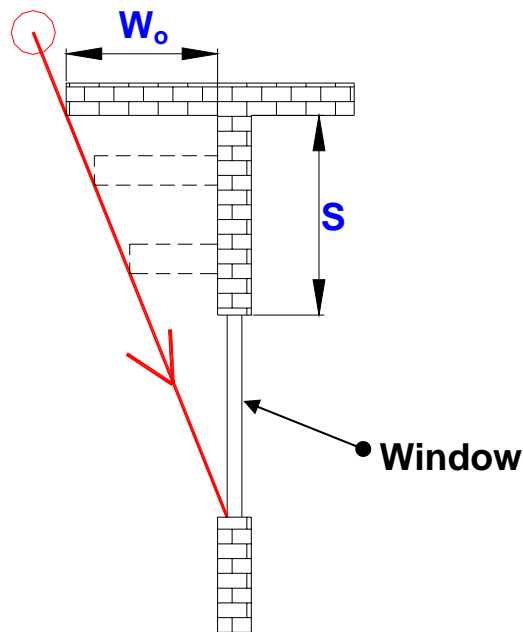
where  $\beta$  is the altitude angle and  $\alpha$  is the wall solar azimuth angle.



**Fig.33.2:** Shadow cast by an inset window

It should be noted that the overhang provides shade against direct solar radiation only and cannot prevent diffuse and reflected radiation. Thus for the shaded portion, the  $SHGF_{max}$  values corresponding to the north facing window in Table 33.1 should be selected.

Using a separation between the top of the window and the overhang, it is possible to completely shade the window in summer and completely unshade it in winter. Complete shading of the window can be provided by selecting infinite combinations of overhang width ( $W_o$ ) and separation dimensions ( $S$ ), as shown in Fig.33.3. It should however be noticed that for complete shading as the separation distance  $S$  increases, the width of the overhang  $W_o$  should also increase and vice versa. ASHRAE defines a **Shade Line Factor (SLF)** which is the ratio of the distance a shadow falls below the edge of an overhang to the width of the overhang. Thus from the knowledge of the SLF and the dimensions of the window with overhang, one can calculate the unshaded area. The average SLF values for 5 hours of maximum on August 21<sup>st</sup> for different latitudes and orientations of the window are presented in tabular form by ASHRAE.



**Fig.33.3:** Variation of overhang width with separation for complete shading

Though overhangs, if properly designed can lead to significant reduction in solar heat gain during summer, they do have certain limitations. These are:

- a) An external overhang provides protection against direct solar radiation only. It cannot reduce diffuse and reflection radiations. In fact, sometimes, the external overhang may actually reflect the ground radiation onto the window.

- b) The reflectivity of the glazed surfaces increases and transmittivity reduces with angle of incidence. Thus in summer when the angle of incidence on a vertical surface is large, most of the solar radiation incident on the glazed surface is reflected back and only about 40% of the incident radiation is transmitted into the building. In such cases, the provision of overhang can take care at the most only 40% of the incident radiation.
- c) For practical purposes, overhangs are truly effective for windows facing 30–45° of south. During mornings and evenings when the sun is striking the east and west walls and is so low in the sky that overhangs can provide only minimum protection.

In spite of the above limitations, a fixed overhang is frequently used as in addition to reducing the direct solar radiation, it also provides protection against rain. The dimensions of the overhang have to be selected depending upon whether passive solar heating in winter is more important or shading in summer. It is also possible to use adjustable overhangs in place of fixed overhangs. However, though the adjustable overhangs are more flexible, and hence can provide greater benefit both in summer and winter, these are not so frequently used due to the operational difficulties and design complexities.

### 33.4. Ventilation for Indoor Air Quality (IAQ):

The quality of air inside the conditioned space should be such that it provides a healthy and comfortable indoor environment. Air inside the conditioned space is polluted by both internal as well as external sources. The pollutants consist of odours, various gases, volatile organic compounds (VOCs) and particulate matter. The internal sources of pollution include the occupants (who consume oxygen and release carbon dioxide and also emit odors), furniture, appliances etc, while the external sources are due to impure outdoor air. **Indoor Air Quality (IAQ)** can be controlled by the removal of the contaminants in the air or by diluting the air. The purpose of ventilation is to dilute the air inside the conditioned space. Ventilation may be defined as the “**supply of fresh air to the conditioned space either by natural or by mechanical means for the purpose of maintaining acceptable indoor air quality**”. Generally ventilation air consists of fresh outdoor air plus any re-circulated air that has been treated. If the outdoor air itself is not pure, then it also has to be treated before supplying it to the conditioned space.

Though the minimum amount of air required for breathing purposes is small (about 0.2 litres per second per person), the actual ventilation air required is much larger as in addition to supplying oxygen to the occupants, the ventilation air must:

- a) Dilute the odours inside the occupied space to a socially acceptable level
- b) Maintain carbon dioxide concentration at a satisfactory level
- c) Pressurizing the escape routes in the event of fire

### 33.4.1. Estimation of minimum outdoor air required for ventilation:

Ventilation is one of the major contributors to total cooling and heating load on the system. From energy conservation point of view, it is important select the ventilation requirements suitably. The amount of air required for ventilation purposes depends on several factors such as: application, activity level, extent of cigarette smoking, presence of combustion sources etc. After several studies stretched over several years, standards for minimum ventilation requirements have been formulated. For example, **ASHRAE standard 62-1989** provides a guideline for minimum ventilation requirements. Table 33.3 provides typical outdoor (OD) air requirement for the purpose of ventilation:

Function	Occupancy per 100 m <sup>2</sup> floor area	OD air requirement per person (L/s)	
		Smoking	Non-smoking
Offices	7	10	2.5
Operation theatres	20	-	15
Lobbies	30	7.5	2.5
Class rooms	50	-	8.0
Meeting places	60	17.5	3.5

**Table 33.3:** Typical outdoor air requirements for ventilation

It can be observed from the above table that the ventilation requirement increases with the occupancy. It can also be seen that the required amount of OD air increases significantly if smoking is permitted in the conditioned space.

### 33.5. Infiltration:

Infiltration may be defined as the uncontrolled entry of untreated, outdoor air directly into the conditioned space. Infiltration of outdoor air into the indoors takes place due to wind and stack effects. The **wind effect** refers to the entry of outdoor air due to the pressure difference developed across the building due to winds blowing outside the building. The **stack effect** refers to the entry of outdoor air due to buoyancy effects caused by temperature difference between the indoor and outdoors. Though infiltration brings in outdoor air into the building similar to ventilation, in many commercial buildings efforts are made to minimize it, as it is uncontrolled and uncertain. Some of the means employed to control infiltration include use of vestibules or revolving doors, use of air curtains, building pressurization and sealing of windows and doors. It is very difficult to estimate the exact amount of infiltration as it depends on several factors such as the type and age of the building, indoor and outdoor conditions (wind velocity and

direction, outdoor temperature and humidity etc.). However, several methods have been proposed to estimate the amount of infiltration air. Sometimes, based on type of construction, buildings are classified into loose, average or tight, and infiltration is specified in terms of number of air changes per hour (ACH). One ACH is equal to the airflow rate equal to the internal volume of the occupied space per hour. The ACH values are related to the outside wind velocity and the temperature difference between the indoor and outdoors. Infiltration rates are also obtained for different types of doors and windows and are available in the form of tables in air conditioning handbooks.

### 33.6. Heating and cooling loads due to ventilation and infiltration:

Due to ventilation and infiltration, buildings gain energy in summer and loose energy in winter. The energy gained or lost consists of both sensible and latent parts, as in general the temperature and moisture content of indoor and outdoors are different both in winter and winter.

The sensible heat transfer rate due to ventilation and infiltration,  $Q_{s,vi}$  is given by:

$$Q_{s,vi} = \dot{m}_o c_{p,m} (T_o - T_i) = \dot{V}_o \rho_o c_{p,m} (T_o - T_i) \quad (33.9)$$

The latent heat transfer rate due to ventilation and infiltration,  $Q_{l,vi}$  is given by:

$$Q_{l,vi} = \dot{m}_o h_{fg} (W_o - W_i) = \dot{V}_o \rho_o h_{fg} (W_o - W_i) \quad (33.10)$$

In the above equations:

$\dot{m}_o$  and  $\dot{V}_o$  are the mass flow rate and volumetric flow rates of outdoor air due to ventilation and infiltration,  $c_{p,m}$  is the average specific heat of moist air,  $h_{fg}$  is the latent heat of vaporization of water,  $T_o$  and  $T_i$  are the outdoor and indoor dry bulb temperatures and  $W_o$  and  $W_i$  are the outdoor and indoor humidity ratios. Thus from known indoor and outdoor conditions and computed or selected values of ventilation and infiltration rates, one can calculate the cooling and heating loads on the building. The sensible and latent heat transfer rates as given by the equations above will be positive during summer (heat gains) and negative during winter (heat losses).

Though the expressions for heat transfer rates are same for both ventilation and infiltration, there is a difference as far as the location of these loads are considered. While heat loss or gain due to infiltration adds directly to the building cooling or heating load, heat loss or gain due to ventilation adds to the equipment load. These aspects will be discussed in a later Chapter.

## Questions & answers:

1. Which of the following statements are TRUE?

- a) Fenestration is important in buildings as it provides visual communication to the outside world
- b) Heat transfer through fenestration generally forms a small part of the total building load
- c) Heat transfer due to fenestration depends only on the properties of the transparent material
- d) Fenestration is undesirable and hence should be minimized

**Ans.: a)**

2. Which of the following statements are TRUE?

- a) External shading of windows is taken care of by using a shading coefficient
- b) Internal shading of windows is taken care of by using a shading coefficient
- c) The shading coefficient for the reference SS glass is 0.0
- d) The shading coefficient for the reference SS glass is 1.0

**Ans.: b) and d)**

3. Which of the following statements are TRUE for northern hemisphere?

- a) Providing fenestration on northern side of the building is beneficial from summer cooling and winter heating points of view
- b) Providing fenestration on southern side of the building is beneficial from summer cooling and winter heating points of view
- c) On an average, the heat transfer due to fenestration is maximum for east and west facing windows
- d) On an average, the heat transfer rate due to fenestration is minimum for north facing windows

**Ans.: b), c) and d)**

4. Which of the following statements are TRUE?

- a) Compared to external shadings, internal shadings are beneficial as they do not allow the radiation into the buildings
- b) Compared to internal shadings, external shadings are beneficial as they block the radiation outside the window itself
- c) The effectiveness of external shading at a particular varies from day to day and from time to time
- d) External shadings are effective for east and west facing windows



**Ans.: b) and c)**

5. Which of the following statements are TRUE?

- a) Ventilation is required for supply of oxygen for breathing only
- b) Ventilation is uncontrolled, while infiltration is controlled
- c) Ventilation requirement depends on occupancy and also on activity level
- d) All of the above

**Ans.: c)**

6. Calculate the maximum heat transfer rate through a 1.5 m<sup>2</sup> area, unshaded, regular double glass facing south during the months of June and December without internal shading and with internal shading consisting of light venetian blinds. Location 32°N

**Ans.:** For the month of June the SHGF<sub>max</sub> from Table 33.1 is 190 W/m<sup>2</sup>. Using the values of shading coefficients from Table 33.2, the heat transfer rate is:

Without internal shading (SC = 0.9):

$$Q_{sg} = A.(SHGF_{max}).(SC) = 1.5 \times 190 \times 0.9 = 256.5 \text{ W} \quad (\text{Ans.})$$

With internal shading (SC = 0.51):

$$Q_{sg} = A.(SHGF_{max}).(SC) = 1.5 \times 190 \times 0.51 = 145.35 \text{ W} \quad (\text{Ans.})$$

These values for the month of December (SHGF<sub>max</sub> = 795 W/m<sup>2</sup>) are:

Without internal shading:  $Q_{sg} = 1073.25 \text{ W}$  **(Ans.)**

With internal shading:  $Q_{sg} = 608.175 \text{ W}$  **(Ans.)**

7. Calculate energy transmitted into a building at 3 P.M on July 21<sup>st</sup> due to solar radiation through a south facing window made of regular single glass. The dimensions of the window are height 2 m, width 1.5 m and the depth of inset 0.3 m. Find the energy transmitted if there is no overhang.

**Ans.:** From the above data the altitude angle  $\beta$  and wall solar azimuth angle  $\alpha$  are found to be:

$$\beta = 48.23^\circ, \alpha = 39.87^\circ$$

Therefore area of the unshaded portion = x X y, where x and y are given by:

$$x = W - d(\tan \alpha) = 1.5 - 0.3(\tan 39.87) = 1.249 \text{ m}$$

$$y = H - d \left( \frac{\tan \beta}{\cos \alpha} \right) = 2.0 - 0.3 \left( \frac{\tan 48.23}{\cos 39.87} \right) = 1.562 \text{ m}$$

∴ The heat transmission rate into the building through the unshaded portion  $Q_{us}$  is given by:

$$Q_{us} = (x \cdot y) \cdot (SHGF_{max}) \cdot SC = (1.249 \times 1.562) \times 230 \times 1.0 = 448.7 \text{ W}$$

The heat transmission rate into the building through the shaded portion  $Q_{ss}$  is given by:

$$Q_{ss} = (W \cdot H - x \cdot y) \cdot (SHGF_{max} \cdot N) \cdot SC = (1.049) \times 120 \times 1.0 = 125.9 \text{ W}$$

Hence the total amount of radiation transmitted into the building,  $Q_{sg}$  is given by:

$$Q_{sg} = Q_{us} + Q_{ss} = 574.6 \text{ W} \quad (\text{Ans.})$$

**Without overhang** the heat transmission rate is:

$$Q_{sg} = (W \times H) SHGF_{max} = 690 \text{ W} \quad (\text{Ans.})$$

Thus there is a reduction of 115.4 W (16.7%) due to external shading. Of course, these values will be different for different periods.

**8.** A large air conditioned building with a total internal volume of 1,00,000 m<sup>3</sup> is maintained at 25°C (DBT) and 50% RH, while the outside conditions are 35°C and 45% RH. It has a design occupancy of 10,000 people, all non-smoking. The infiltration rate through the building is equal to 1.0 ACH. Estimate the heat transfer rate due to ventilation and infiltration. Assume the barometric pressure to be 1 atm.

**Ans.:** From psychrometric chart:

For inside conditions: 24°C (DBT) and 50% RH:

$$W_i = 0.0093 \text{ kgw/kgda}, h_i = 47.656 \text{ kJ/kgda}$$

For outside conditions: 35°C (DBT) and 45% RH:

$$W_o = 0.01594 \text{ kgw/kgda}, h_o = 75.875 \text{ kJ/kgda} \text{ and } v_a = 0.89519 \text{ m}^3/\text{kg}$$

**Heat transfer due to ventilation:**

From Table 33.3, assume a ventilation requirement of **3.5 l/s/person**. Hence the total OD air required is:

$$V_{o,v} = 3.5 \times 10,000 = 35000 \text{ l/s} = 35 \text{ m}^3/\text{s}$$

Hence the mass flow rate of ventilated air is:

$$m_{o,v} = 35 / 0.89519 = 39.1 \text{ kg/s}$$

Sensible heat transfer rate due to ventilation is given by:

$$Q_{s,v} = m_{o,v} c_{pm} (t_o - t_i) = 39.1 \times 1.0216 \times (35 - 25) = 399.5 \text{ kW}$$

Latent heat transfer rate due to ventilation is given by:

$$Q_{l,v} = m_{o,v} h_{fg} (W_o - W_i) = 39.1 \times 2501 \times (0.01594 - 0.0093) = 649.3 \text{ kW}$$

Hence total heat transfer rate due to ventilation is:

$$Q_{t,v} = Q_{s,v} + Q_{l,v} = 1048.8 \text{ kW} \quad (\text{Ans.})$$

#### Heat transfer rate due to infiltration:

$$\text{Infiltration rate, } V_{inf} = 1 \text{ ACH} = 1,00,000/3600 = 27.78 \text{ m}^3/\text{s}$$

Hence mass flow rate of infiltrated air is:

$$m_{inf} = V_{inf}/v_a = 27.78/0.89519 = 31 \text{ kg/s}$$

Hence using expressions similar to ventilation, the sensible, latent and total heat transfer rates due to infiltration are found to be:

$$Q_{s,inf} = 316.7 \text{ kW} \quad (\text{Ans.})$$

$$Q_{l,inf} = 514.8 \text{ kW} \quad (\text{Ans.})$$

$$Q_{t,inf} = 831.5 \text{ kW} \quad (\text{Ans.})$$

It can be seen from the above example that the total load on the air conditioning system is very high ( = 1880.3 kW = 534.6 TR).

# Lesson

34

Cooling And Heating

Load Calculations

-Heat Transfer Through

Buildings - Fabric Heat

Gain/Loss

## The specific objectives of this chapter are to:

1. Discuss the general aspects of heat transfer through buildings (*Section 34.1*)
2. Discuss one-dimensional, steady state heat transfer through homogeneous, non-homogeneous walls, through air spaces and through composite walls of the buildings (*Section 34.2*)
3. Discuss unsteady heat transfer through opaque walls and roofs (*Section 34.3*)
4. Discuss one-dimensional, unsteady heat transfer through opaque walls and roofs with suitable initial and boundary conditions (*Section 34.4*)
5. Describe the analytical method used to solve the 1-D, transient heat transfer problem through building walls and roofs (*Section 34.4.1*)
6. Briefly discuss the numerical methods used to solve the transient heat transfer problem (*Section 34.4.2*)
7. Discuss the semi-empirical methods based on Effective Temperature Difference or Cooling Load Temperature Difference, discuss the physical significance of decrement and time lag factors and present typical tables of CLTD for walls and roof (*Section 34.4.3*)

At the end of the chapter, the student should be able to:

1. Calculate the steady heat transfer rates through homogeneous and non-homogeneous walls, through composite walls consisting of a combination of homogeneous and non-homogeneous walls and air spaces
2. Explain the need for considering transient heat transfer through buildings
3. Derive one-dimensional, transient heat conduction equation for building walls and roof and indicate suitable initial and boundary conditions
4. Discuss the general aspects of the analytical, numerical and semi-empirical methods used to solve the transient building heat transfer problem
5. Use the ETD/CLTD methods to estimate heat transfer rate through opaque walls and roof of the buildings

### 34.1. Introduction:

Whenever there is a temperature difference between the conditioned indoor space of a building and outdoor ambient, heat transfer takes place through the building structure (walls, roof, floor etc.). This is known as fabric heat gain or loss, depending upon whether heat transfer is to the building or from the building, respectively. The fabric heat transfer includes sensible heat transfer through all the structural elements of a building, but does not include radiation heat transfer through fenestration. Exact analysis of heat transfer through building structures is very complex, as it has to consider:

- a) Geometrically complex structure of the walls, roofs etc. consisting of a wide variety of materials with different thermo-physical properties.
- b) Continuously varying outdoor conditions due to variation in solar radiation, outdoor temperature, wind velocity and direction etc.

- c) Variable indoor conditions due to variations in indoor temperatures, load patterns etc.

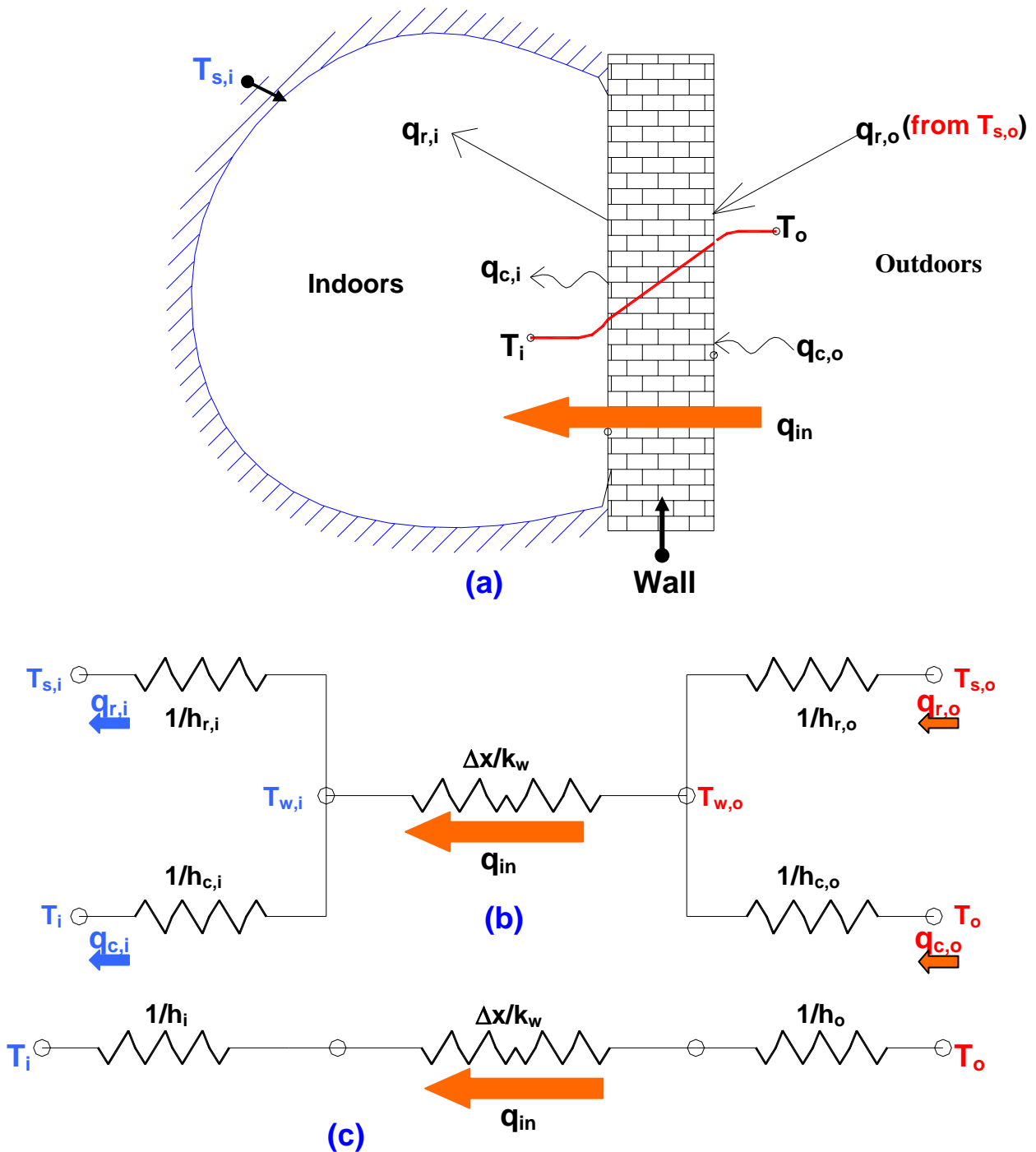
For cooling and heating load calculations, the indoor conditions are generally assumed to be constant to simplify the analysis. However, the variation in outdoor conditions due to solar radiation and ambient temperature has to be considered in the analysis to arrive at realistic cooling loads during summer. In winter, the heating load calculations are based on peak or near-peak conditions, which normally occur early in the morning before sunrise, in addition, in cold countries, the ambient temperature variation during the winter months is not significant. Hence, in conventional heating load calculations, the effects of solar radiation and ambient temperature variation are not considered and the heat transfer is assumed to be steady. However by this steady state method, the calculated heating capacity will be more than required. Thus for higher accuracy, it is essential to consider the transient heat transfer effects during winter also. In the present lecture, first steady state heat transfer through buildings will be discussed followed by the unsteady state heat transfer.

### 34.2. One-dimensional, steady state heat transfer through buildings:

Heat transfer through the building is assumed to be steady, if the indoor and outdoor conditions do not vary with time. The heat transfer is assumed to be one-dimensional if the thickness of the building wall is small compared to the other two dimensions. In general, all building walls are multi-layered and non-homogeneous and could be non-isotropic. To start with we consider a single layered, homogeneous wall and then extend the discussion to multi-layered, non-homogenous walls.

### 34.2.1. Homogeneous wall:

Figure 34.1(a) shows a homogeneous wall separating the conditioned indoor space from the outdoors. As shown in the figure, the wall is subjected to radiation



**Fig.34.1:** Steady state heat transfer through a building wall and the resistance network

and convection heat transfer on both sides, while heat transfer through the wall is by conduction.

If outside and inside conditions do not vary with time, then the heat transfer through the wall is steady, and we can construct a heat transfer network considering various heat transfer resistances as shown in Fig.34.1(b). The heat transfer rate per unit area of the wall  $q_{in}$  under steady state is given by:

$$q_{in} = \{q_{c,o} + q_{r,o}\} = \{q_{c,i} + q_{r,i}\} \quad \text{W/m}^2 \quad (34.1)$$

where  $q_{c,o}$  and  $q_{r,o}$  are the convective and radiative heat transfers to the outer surface of the wall from outside and  $q_{c,i}$  and  $q_{r,i}$  are the convective and radiative heat transfers from the inner surface of the wall to the indoors, respectively. Writing the radiative heat transfer in terms of a linearized radiative heat transfer coefficient, we can write the heat transfer rate per unit area as:

$$q_{in} = h_o(T_o - T_{w,o}) = h_i(T_{w,i} - T_i) \quad \text{W/m}^2 \quad (34.2)$$

where  $T_i$  and  $T_o$  are the indoor and outdoor air temperatures,  $T_{w,i}$  and  $T_{w,o}$  are the inner and outer surface temperatures of the wall respectively. In the above equation,  $h_i$  and  $h_o$  are the inner and outer surface heat transfer coefficients or surface conductances, which take into account both convection and radiation heat transfers. From the resistance network, it can easily be shown that the surface conductances  $h_i$  and  $h_o$  are given by:

$$h_i = h_{c,i} + h_{r,i} \left( \frac{T_{w,i} - T_{s,i}}{T_{w,i} - T_i} \right) \quad (34.3)$$

$$h_o = h_{c,o} + h_{r,o} \left( \frac{T_{s,o} - T_{w,o}}{T_o - T_{w,o}} \right) \quad (34.4)$$

The convective heat transfer coefficient depends on whether heat transfer is by natural convection or forced convection. Normally the air inside the conditioned space is assumed to be still as the required air velocities in the conditioned space are very small. Hence, the inside convective heat transfer coefficient  $h_{c,i}$  can be calculated using heat transfer correlations for natural convection. For example, for still air  $h_{c,i}$  can be estimated using the following simple correlation:

$$h_{c,i} = 1.42 \left( \frac{\Delta T}{L} \right)^{\frac{1}{4}} \quad \text{W/m}^2.\text{K} \quad (34.5)$$

where  $\Delta T$  is the temperature difference between the inner surface of the wall and the still air, and  $L$  is the length of the wall. Of course, the actual heat transfer coefficient will be slightly higher due to the finite air motion inside the conditioned space.

Normally due to wind speed, the heat transfer from the outside air to the outer surface of the wall is by forced convection. Hence to estimate the outer convective heat transfer coefficient  $h_{c,o}$ , suitable forced convective heat transfer correlations should be used.

The linearized radiative heat transfer coefficient is calculated from the equation:

$$h_r = \left( \frac{\varepsilon \sigma}{T_1 - T_2} \right) (T_1^4 - T_2^4) \quad \text{W/m}^2.\text{K} \quad (34.6)$$

where  $\varepsilon$  is the emissivity of the surface,  $\sigma$  is the Stefan-Boltzmann's constant ( $5.673 \times 10^{-8} \text{ W/m}^2.\text{K}^4$ ),  $T_1$  and  $T_2$  are the hot and cold surface temperatures (in K) respectively.

Table 34.1 shows typical surface conductance values, which can be used for estimating inner and outer heat transfer coefficients ( $h_i$  and  $h_o$ ). When the air is still (i.e., for the inside heat transfer coefficient), the order-of-magnitude of convective heat transfer is almost same as that of the radiative heat transfer coefficient, as a



result, the emissivity of the surface plays an important role and the surface conductance increases with emissivity as shown in the table. On the other hand, when the air is blowing at considerable speed (i.e., for external heat transfer coefficient), the convection heat transfer coefficient is many times larger than the radiative heat transfer coefficient, as a result, the effect of emissivity of the surface is not important.

Orientation of Surface	Air Velocity	Direction of heat flow	Surface emissivity		
			0.9	0.7	0.5
Horizontal	Still Air	Up	9.4	5.2	4.4
Horizontal	Still Air	Down	6.3	2.2	1.3
Vertical	Still Air	Horizontal	8.5	4.3	3.5
Any position	3.7 m/s	Any	23.3	-	-
Any position	6.4 m/s	Any	35	-	-

**Table 34.1:** Surface conductance values in  $W/m^2.K$  for different orientations, air velocities and surface emissivity (C.P. Arora)

Eliminating the surface temperatures of the wall ( $T_{w,i}$  and  $T_{w,o}$ ), the steady state heat transfer rate per unit area of the wall can be written in terms of the indoor and outdoor air temperatures and the overall heat transfer coefficient, i.e.,

$$q_{in} = U(T_o - T_i) = \frac{(T_o - T_i)}{R_{tot}} \quad W/m^2 \quad (34.7)$$

where  $U$  is the overall heat transfer coefficient and  $R_{tot}$  is the total resistance to heat transfer. From the heat transfer network, the expression for overall heat transfer coefficient is given by:

$$\left(\frac{1}{U}\right) = \left(\frac{1}{h_i} + \frac{\Delta x}{k_w} + \frac{1}{h_o}\right) = R_{tot} \quad (W/m^2.K) \quad (34.8)$$

where  $\Delta x$  and  $k_w$  are the thickness and thermal conductivity of the wall, respectively.

If the wall consists of windows, doors etc., then the overall heat transfer  $U_o$  is obtained using the individual  $U$ -values and their respective areas as:

$$U_o = (U_{wall} \cdot A_{wall} + U_{door} \cdot A_{door} + U_{window} \cdot A_{window} \dots) / A_{total} \quad (34.9)$$

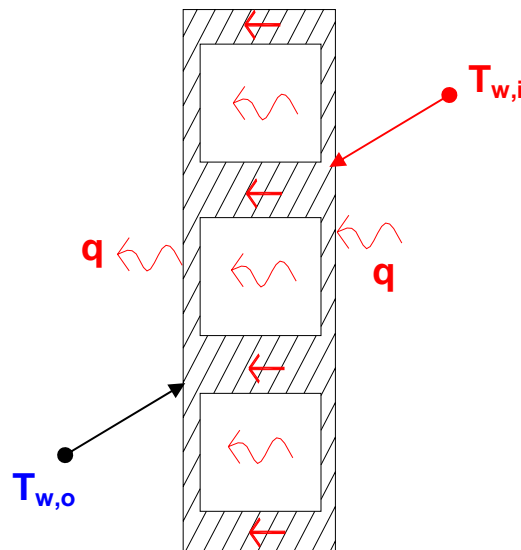
where  $U_{wall}$ ,  $U_{door}$ ,  $U_{window}$  etc. are the overall heat transfer coefficients for the wall, door, window etc., which are obtained using Eqn.(34.8), and  $A_{wall}$ ,  $A_{door}$ ,  $A_{window}$  are the corresponding areas.  $A_{total}$  is the total area of the wall that includes doors, windows etc. The above equation for overall heat transfer coefficient (Eqn.(34.9)) is valid when the temperature difference across the wall components are same and the heat transfer paths through these elements are parallel.

### 34.2.2. Non-homogeneous walls:

In general the building walls may consist of non-homogeneous materials such as hollow bricks. Heat transfer through non-homogeneous materials such as hollow bricks is quite complicated as it involves simultaneous heat transfer by convection, conduction and radiation as shown in Fig.34.2. The heat transfer network consists of series as well as parallel paths due to the simultaneous modes of heat transfer. In practice, all these effects are lumped into a single parameter called **thermal conductance**,  $C$ , and the heat flux through the hollow brick is given by:

$$q = C(T_{w,o} - T_{w,i}) \quad \text{W/m}^2 \quad (34.10)$$

The conductance values of common building materials have been measured and are available in tabular form in ASHRAE and other handbooks. Table 34.2 shows thermo-physical properties of some commonly used building materials.



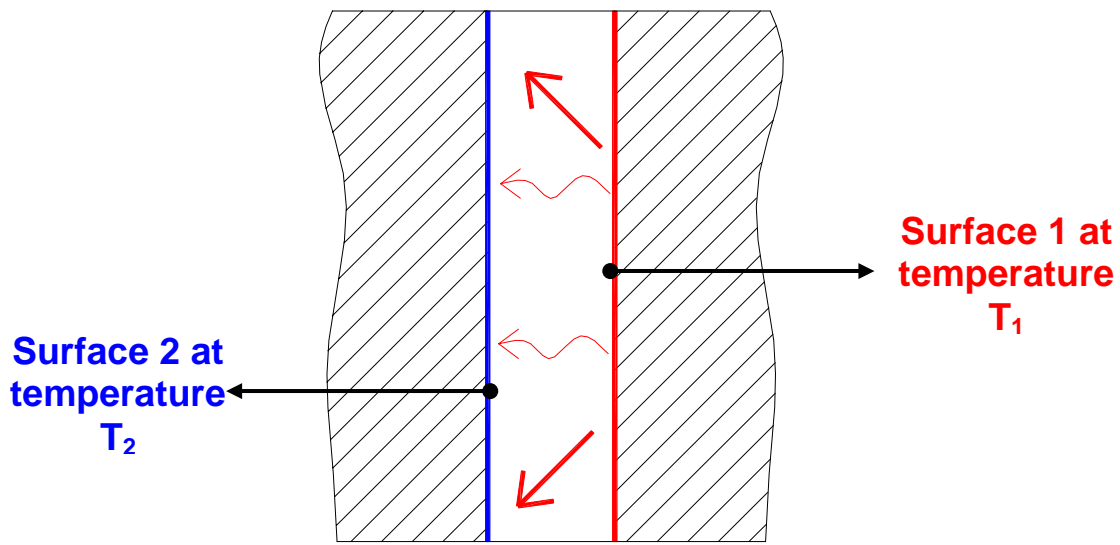
*Fig.34.2: Heat transfer through a non-homogeneous wall*

Material	Description	Specific heat kJ/kg.K	Density kg/m <sup>3</sup>	Thermal conductivity k <sub>w</sub> , W/m.K	Conductance C, W/m <sup>2</sup> .K
<b>Bricks</b>	Common	0.84	1600	0.77	
	Face brick	0.84	2000	1.32	
	Firebrick	0.96	2000	1.04 – 1.09	
<b>Woods</b>	Ply	-	544	0.1	
	Hard	2.39	720	0.158	
	Soft	2.72	512	0.1	
<b>Masonry Materials</b>	Concrete	0.88	1920	1.73	
	Plaster, Cement	0.796	1885	8.65	
	Hollow Clay tiles				
	a) 10 cm	-	-	-	5.23
	b) 20 cm	-	-	-	3.14
	c) 30 cm	-	-	-	2.33
	Hollow Concrete blocks				
	d) 10 cm	-	-	-	8.14
	e) 20 cm	-	-	-	5.23
	f) 30 cm	-	-	-	4.54
Foam concrete (Pre-cast slabs for roof)		210-704	0.043-0.128		
<b>Glass</b>	Window	0.84	2700	0.78	
	Borosilicate		2200	1.09	
<b>Insulating Materials</b>	Mineral or glass wool	0.67	24-64	0.038	
	Fiberglass board	0.7	64-144	0.038	
	Cork board	1.884	104-128	0.038	
	Cork granulated	1.88	45-120	0.045	
	Thermocole (EPS)	-	30	0.037	
	Diatomaceous Earth	-	320	0.061	
	Felt	-	330	0.052	
	Magnesia	-	270	0.067	
	Asbestos	0.816	470-570	0.154	

**Table 34.2:** Thermo-physical properties of some common building and insulating materials (C.P. Arora)

### 34.2.3. Air spaces:

Buildings may consist of air spaces between walls. Since air is a bad conductor of heat, the air space provides effective insulation against heat transfer. Heat transfer through the air space takes place by a combined mechanism of conduction, convection and radiation as shown in Fig. 34.3.



**Fig.34.3:** Heat transfer through an air space in the wall

Thus the heat transfer rate through the air spaces depends upon its width, orientation and surface emissivities of the wall surfaces and the temperature difference between the two surfaces. Heat transfer by conduction is considerable only when the thickness of the air space is very small. Studies show that beyond an air gap of about 2 cms, the effect of conduction heat transfer is negligible, and heat transfer is predominantly by convection and radiation. Since the thickness of the air spaces varies normally from 5 cms to 55 cms (e.g. for false ceilings), the effect of conduction may be neglected. In such a case, the heat flux through the air space is given by:

$$q = C(T_1 - T_2) \quad \text{W/m}^2 \quad (34.11)$$

where C is the conductance of the air space that includes the radiation as well as convection effects. Assuming the heat transfer coefficient  $h_c$  to be same for both the surfaces (i.e., when air is well-mixed in the air space), the air temperature to be uniform and the surfaces 1 and 2 to be infinite parallel planes, it can be shown that the conductance C is given by:

$$C = \left( \frac{h_c}{2} + h_r \right) \quad \text{W/m}^2 \cdot \text{K} \quad (34.12)$$

The linearized radiative heat transfer coefficient  $h_r$  is given by:

$$h_r = \left( \frac{F_{12} \sigma}{T_1 - T_2} \right) (T_1^4 - T_2^4) \quad \text{W/m}^2 \cdot \text{K} \quad (34.13)$$

where the view factor  $F_{12}$  is given by:

$$F_{12} = \frac{1}{\left[ \left( \frac{1}{\epsilon_1} \right) + \left( \frac{1}{\epsilon_2} \right) - 1 \right]} \quad (34.14)$$

where  $\varepsilon_1$  and  $\varepsilon_2$  are the emissivities of surfaces 1 and 2, respectively. Table 34.3 shows the typical conductance values for the air spaces commonly encountered in buildings.

Position & Mean Temp. difference	Direction of heat flow	Width of air space, cm	Conductance, W/m <sup>2</sup> .K
Horizontal, 10°C	Up	2.1	6.7
		11.6	6.2
	Down	2.1	5.7
		4.2	5.1
		11.6	4.8
	Vertical, 10°C	Horizontal	2.1
11.6			5.8
Horizontal, 32°C	Up	2.1	7.7
		11.6	7.2
	Down	2.1	7.0
		4.2	6.2
		11.6	5.8
	Vertical, 32°C	Horizontal	2.1
11.6			6.9

**Table 34.3:** Typical conductance values of air spaces (C.P. Arora)

#### 34.2.4. Multi-layered, composite walls:

In general, a building wall may consist of several layers comprising of layers of homogeneous and non-homogeneous wall materials made up of structural and insulating materials and air spaces. For such a multi-layered wall, one can write the heat transfer rate per unit area as:

$$q_{in} = U(T_o - T_i) = \frac{(T_o - T_i)}{R_{tot}} \quad \text{W/m}^2 \quad (34.15)$$

where the overall heat transfer coefficient U is given as:

$$\left(\frac{1}{U}\right) = R_{tot} = \left(\frac{1}{h_i}\right) + \sum_{i=1}^N \left(\frac{\Delta x_i}{k_{w,i}}\right) + \sum_{j=1}^M \left(\frac{1}{C_j}\right) + \left(\frac{1}{h_o}\right) \quad (34.16)$$

Thus from the structure of the wall, various material properties and conductance values of non-homogeneous materials and air spaces and inner and outer surface temperatures and conductance, one can calculate the heat transfer rate under steady state conditions. It should be kept in mind that the equations given above are limited to plane walls. For non-planar walls (e.g. circular walls), the contour of the walls must be taken into account while calculating heat transfer rates.

### 34.3. Unsteady heat transfer through opaque walls and roofs:

In general, heat transfer through building walls and roof is unsteady, this is particularly so in summer due to solar radiation and varying ambient temperature. In the calculation of unsteady heat transfer rates through buildings, it is essential to

consider the thermal capacity of the walls and roof. Due to the finite and often large thermal capacity of the buildings, the heat transfer rate from outside to the outer surface is not equal to the heat transfer rate from the inner surface to the indoor space<sup>1</sup>. In addition, the thermal capacity of the buildings introduces a time lag. These aspects have to be considered in realistic estimation of building cooling loads. This makes the problem mathematically complex. Though the conduction through the building walls and roof could be multi-dimensional, for the sake of simplicity a one-dimensional heat transfer is normally considered. It is to be noted that when the heat transfer is not steady, the concept of simple resistance network as discussed before cannot be used for obtaining heat transfer rate through the wall.

### 34.4. One-dimensional, unsteady heat transfer through building walls and roof:

For the sake of simplicity, it is assumed that the wall is made of a homogeneous material. It is also assumed that the temperature of the conditioned space is kept constant by using a suitable air conditioning system. Figure 34.4 shows a wall of thickness  $L$  subjected to unsteady heat transfer. As shown in the figure the outer surface of the wall ( $x=L$ ) is subjected to direct and diffuse radiations from the sun ( $\alpha_D I_D$  and  $\alpha_d I_d$ ), reflected radiation from the outer wall to the surrounding surfaces ( $R$ ) and convective heat transfer from outdoor air to the outer surface of the wall ( $h_o(T_o - T_{w,o})$ ). Heat transfer from the inner surface to the conditioned space takes place due to combined effects of convection and radiation ( $h_i(T_{w,i} - T_o)$ ).

Applying energy balance equation to the outer surface of the wall ( $x = L$ ) at any instance of time  $\theta$ , we can write:

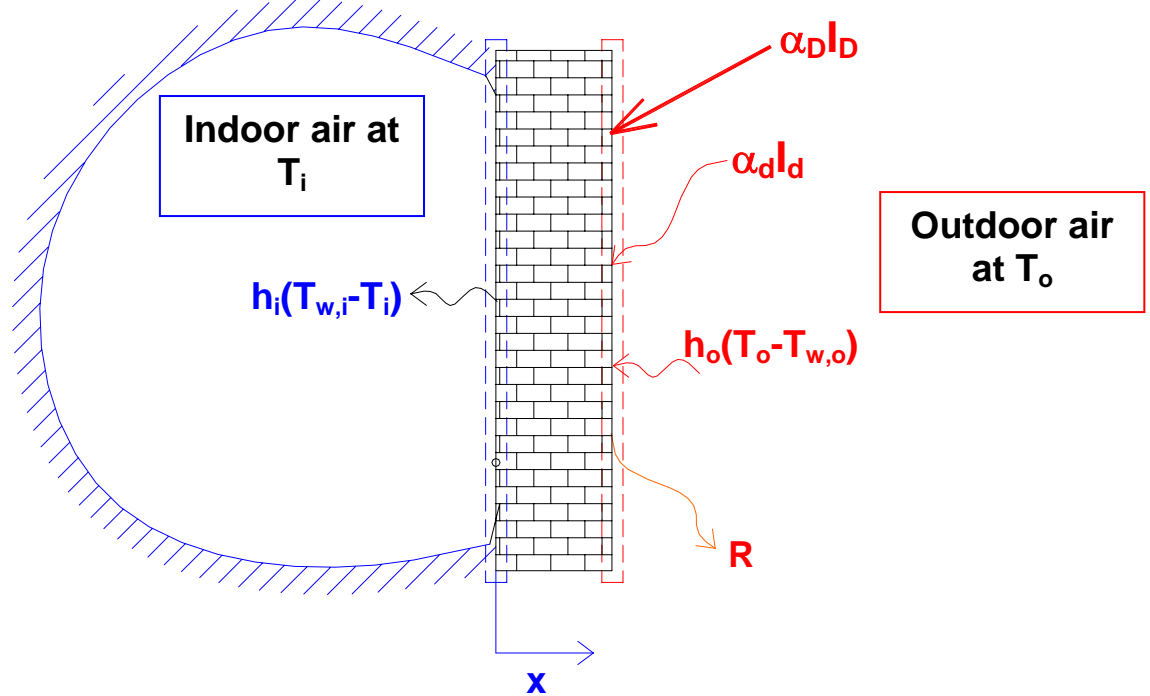
$$q_{x=L,\theta} = -k_w \left( \frac{\partial T}{\partial x} \right)_{x=L,\theta} = h_o(T_o - T_{x=L}) + \alpha_D I_D + \alpha_d I_d - R \quad (34.17)$$

Applying energy balance equation to the inner surface of the wall ( $x = 0$ ), we can write:

$$q_{x=0,\theta} = -k_w \left( \frac{\partial T}{\partial x} \right)_{x=0,\theta} = h_i(T_{x=0} - T_i) \quad (34.18)$$

---

<sup>1</sup> If the thermal capacity of the wall is small (e.g. for a thin door), the heat transfer will still be transient due to changing outdoor conditions. However, at any point of time the heat transfer rate at the outer surface is equal to the heat transfer rate at the inner surface, i.e.,  $q_{o,\theta} = q_{i,\theta}$  due to negligible thermal storage effect



**Fig.34.4.** Unsteady heat transfer through a building wall

In general due to the finite thermal capacity of the walls; at any point of time  $\theta$ , the heat transfer rate at the outer surface is not equal to the heat transfer rate at the inner surface, i.e.,

$$\mathbf{q}_{x=L,\theta} \neq \mathbf{q}_{x=0,\theta} \quad (34.19)$$

For cooling load calculations, we need to know the heat transfer rate from the inner surface of the wall to the conditioned space at a given time  $\theta$ , i.e.,  $\mathbf{q}_{x=0,\theta}$ . From Eq.(34.18), to calculate  $\mathbf{q}_{x=0,\theta}$ , we need to know the temperature distribution  $(\partial T/\partial x)$  inside the wall so that we can calculate  $(\partial T/\partial x)_{x=0,\theta}$  and  $\mathbf{q}_{in}$  from Eq.(34.18). To find the temperature distribution inside the wall, one has to solve the transient heat conduction equation as the mode of heat transfer through the solid wall is assumed to be by conduction only. Assuming the variation in thermal properties of the solid wall to be negligible, the one-dimensional, transient heat conduction equation through the plane wall is given by:

$$\frac{\partial^2 T}{\partial x^2} = \frac{1}{\alpha} \left( \frac{\partial T}{\partial \theta} \right) \quad (34.20)$$

In the above equation,  $\alpha$  is the thermal diffusivity ( $\alpha = k_w/\rho_w c_{pw}$ ),  $x$  is the length coordinate and  $\theta$  is the time coordinate. To solve the above partial differential equation, an initial condition and two boundary conditions are required to be specified. The initial condition could be a known temperature gradient at a particular time,  $\theta = 0$ , i.e.,

$$T_{x,\theta=0} = T_i(x) \quad (34.21)$$

The two boundary conditions at  $x = L$  and  $x = 0$  are given by Eqs.(34.17) and (34.18). The boundary condition at  $x = L$ , i.e., Eq.(34.17) can be written as:

$$q_{x=L,\theta} = -k_w \left( \frac{\partial T}{\partial x} \right)_{x=L,\theta} = h_o (T_o - T_{x=L}) + \alpha_D I_D + \alpha_d I_d - R = h_o (T_{\text{sol-air}} - T_{x=L}) \quad (34.22)$$

where  $T_{\text{sol-air}}$  is known as the **sol-air temperature** and is an equivalent or an effective outdoor temperature that combines the effects of convection and radiation. From the above equation the sol-air temperature is given by:

$$T_{\text{sol-air}} = T_o + \left( \frac{\alpha_D I_D + \alpha_d I_d - R}{h_o} \right) \quad (34.23)$$

It can be easily seen that in the absence of any radiation, the sol-air temperature is simply equal to the outdoor air temperature. The difference between the sol-air temperature and ambient air temperature increases as the amount of radiation incident on the outer surface increases and/or the external heat transfer coefficient decreases. Since on any given day, the outdoor air temperature and solar radiation vary with time, the sol-air temperature also varies with time in a periodic manner.

In terms of the sol-air temperature the boundary condition at  $x=L$  is written as:

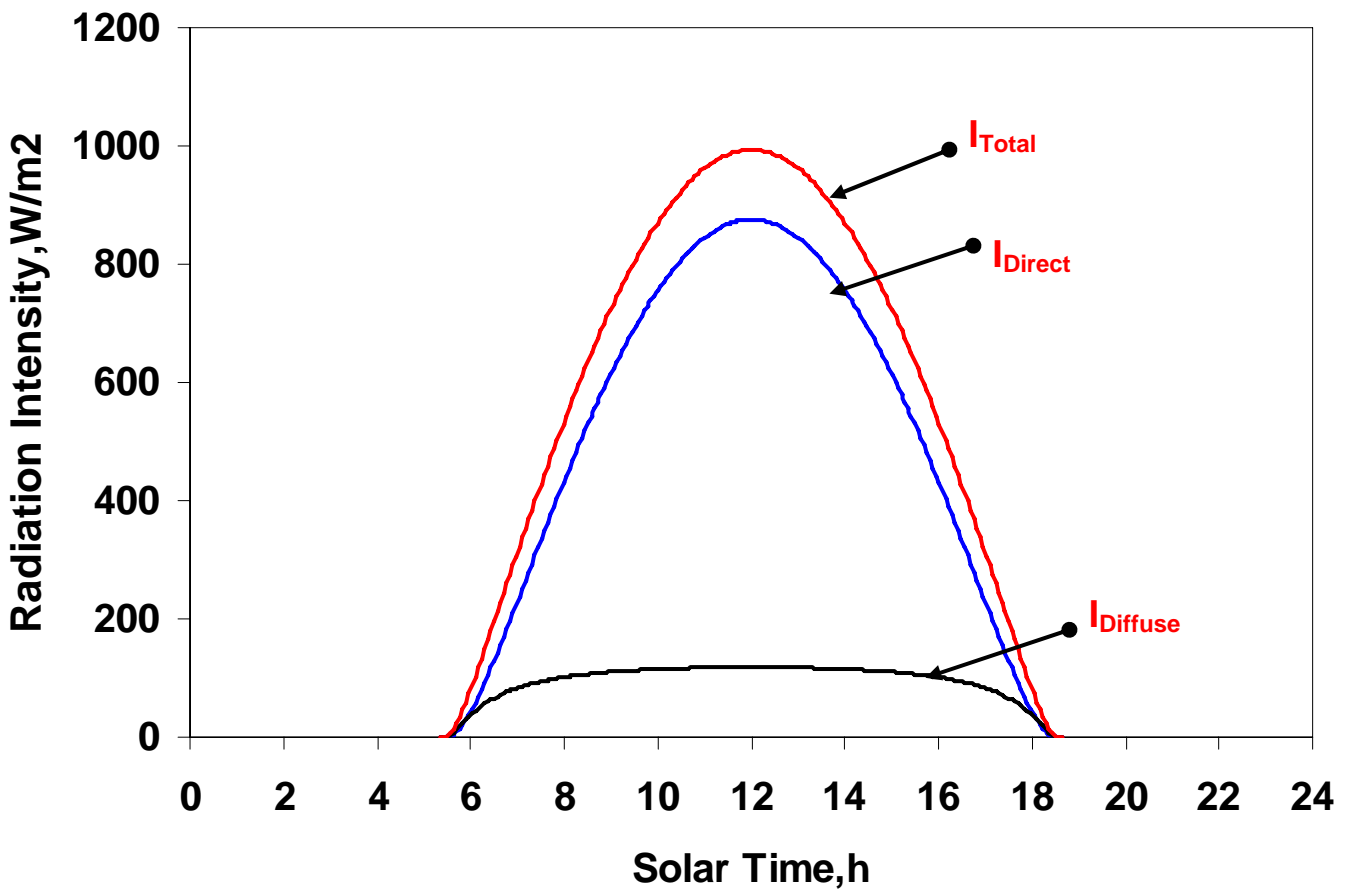
$$q_{x=L,\theta} = -k_w \left( \frac{\partial T}{\partial x} \right)_{x=L,\theta} = h_o (T_{\text{sol-air}} - T_{x=L}) \quad (34.24)$$

Thus the one-dimensional unsteady heat transfer equation through the plane wall given by Eq.(34.20) should be solved using the initial condition given by Eq.(34.21) and the boundary conditions given by Eqs.(34.18) and (34.24). This problem can be solved by an analytical method involving an infinite harmonic series or by using numerical techniques such as finite difference or finite volume methods or by using semi-empirical methods.

#### 34.4.1. Analytical solution:

Analytical solutions to transient transfer through building walls and roof are available for simple geometries. To simplify the problem further it is generally assumed that the outdoor air temperature and solar radiation intensity vary in a periodic manner. In addition, normally the indoor temperature and thermal properties of the wall materials are assumed to be constant. Though the variation of ambient temperature and solar radiation is highly erratic and hence non-periodic due mainly to the presence of clouds and other climatic factors, the assumption of periodic variation is justified if one assumes a clear sky. For example Fig.34.5, shows the direct, diffuse and total radiation intensity on a horizontal roof under clear sky conditions. It can be seen that the variation is periodic with the peak occurring at the solar noon. Applying periodic boundary condition at the outer surface, the analytical solution is obtained in terms of an infinite Fourier series consisting of various harmonics.





**Fig.34.5:** Variation of direct, diffuse and total solar radiation on a horizontal surface with time under clear sky conditions

The sol-air temperature at any instant  $\theta$  is given by (Threlkeld):

$$T_{\text{sol-air},\theta} = T_{\text{sol-air},m} + M_1 \cos \varpi_1 \theta + N_1 \sin \varpi_1 \theta + M_2 \cos \varpi_2 \theta + N_2 \sin \varpi_2 \theta + \dots \quad (34.25)$$

Where the mean sol-air temperature  $T_{\text{sol-air},m}$  is obtained by averaging the instantaneous sol-air temperature over a 24-hour period, i.e. by integrating  $T_{\text{sol-air}}$  using Eqn.(34.23) over a 24 hour period. Hence it is given by:

$$T_{\text{sol-air},m} = \frac{1}{24} \int_0^{24} T_{\text{sol-air}} d\theta \quad (34.26)$$

The coefficients  $M_n$  and  $N_n$  are given by:

$$M_n = \frac{1}{12} \int_0^{24} T_{\text{sol-air}} \cos \varpi_n \theta d\theta \quad (34.27)$$

$$N_n = \frac{1}{12} \int_0^{24} T_{\text{sol-air}} \sin \varpi_n \theta d\theta \quad (34.28)$$

In the above expressions, the value of  $n$  can be restricted to 2 or 3 as higher order terms do not contribute significantly. In the above expressions,  $\varpi_n$  is the angular velocity, and  $\varpi_1 = \pi/12$  radians per hour or  $15^\circ$  per hour and  $\varpi_n = n\varpi_1$ . The coefficients  $M_1, M_2, \dots$  and  $N_1, N_2, \dots$  are obtained from Eqns.(34.27) and (34.28). All the calculations are based on solar time, and  $\theta$  is taken as 0 hours at 12'O clock

midnight. Thus using the above equations, the sol-air temperature at an instance can be calculated for clear days at any location. Now using the above series expression for sol-air temperature, the solution of the unsteady heat conduction equation yields expression for wall temperature as a function of  $x$  and  $\theta$  as:

$$T_{x,\theta} = A + Bx + \sum_{n=1}^{\infty} (C_n \cos P_n \cdot mx + D_n \sin P_n \cdot mx) e^{(-m^2 \varpi_n \theta)} \quad (34.29)$$

where A, B, C and D are constants, and  $m = \sqrt[4]{-1}$ . The coefficients A, B,  $C_n$  and  $D_n$  can be either real or complex. However, in the solution only the real parts are considered. Then it is shown that the inner wall temperature (i.e, at  $x = 0$ ) the temperature is given by:

$$T_{x=0,\theta} = T_{x=0,0} + \frac{1}{h_i} \left[ U(T_{e,m} - T_{x=0,0}) + V_1 T_{e,1} \cos(\varpi_1 \theta - \psi_1 - \phi_1) + V_2 T_{e,2} \cos(\varpi_2 \theta - \psi_2 - \phi_2) \dots \right] \quad (34.30)$$

where  $T_e$  stands for the sol-air temperature ( $T_{\text{sol-air}}$ ) and ;

$$U = \frac{1}{\frac{1}{h_i} + \frac{L}{k_w} + \frac{1}{h_o}} \quad (34.31)$$

$$V_n = \frac{h_i h_o}{\sigma_n k_w \sqrt{Y_n^2 + Z_n^2}} \quad (34.32)$$

$$\sigma_n = \sqrt{\frac{\varpi_n}{2\alpha_w}}; \text{ and } \alpha_w = \frac{k_w}{\rho_w c_{p,w}} = \text{Thermal diffusivity of the wall} \quad (34.33)$$

The constants  $Y_n$  and  $Z_n$  in Eqn.(34.34) are expressed in terms of  $h_i$ ,  $h_o$ ,  $\sigma_n$ ,  $L$ ,  $k_w$ .

The term  $\phi_n$  in Eqn.(34.30) is called as **Time Lag** factor and is given by:

$$\phi_n = \tan^{-1} \left( \frac{Z_n}{Y_n} \right) \quad (34.34)$$

The rate of heat transfer from the inner surface is also shown to be in the form of an infinite series as shown below:

$$q_{x=0,\theta} = U \left\{ T_{e,m} + \lambda_1 T_{e,1} \cos(\varpi_1 \theta - \psi_1 - \phi_1) + \lambda_2 T_{e,2} \cos(\varpi_2 \theta - \psi_2 - \phi_2) \right\} - T_{x=0,0} \quad (34.35)$$

In the above expression the quantity  $\lambda_n$  is called as **decrement factor** and as mentioned before,  $\phi_n$  is the as time lag factor. The factor  $\psi_n$  takes into account the inner and outer heat transfer coefficients, thickness and thermal properties of the wall etc. The expressions for decrement factor  $\lambda_n$  and factor  $\psi_n$  are given by:

$$\lambda_n = \frac{V_n}{U}; \quad \text{and} \quad \psi_n = \tan^{-1} \left( \frac{N_n}{M_n} \right) \quad (34.36)$$

### 34.4.2. Numerical methods:

The analytical method discussed above, though gives an almost exact solution, becomes very complex for other geometries or boundary conditions. The numerical techniques are very powerful and are very useful for solving the unsteady conduction equations with a wide variety of boundary conditions, variable properties and irregular shapes. However, the use of numerical methods requires a powerful computer, and the solution obtained is not exact and is prone to errors if not applied properly. Nevertheless, at present with the advent of computers, the numerical method is the preferred method due to its versatility and flexibility. The commonly used numerical methods are: finite difference method, finite element method, finite volume method etc. In general, the principle of all numerical methods is to write the continuous functions such as temperature in discrete forms by dividing the domain of interest into a large number of grids or elements. Due to discretization, the governing partial differential equations get converted into a set of algebraic equations, which then are solved to get the parameters of interest in the domain. The reader should refer to any book on Numerical Methods for further details on these techniques.

### 34.4.3. Semi-empirical methods:

The semi-empirical methods use the form suggested by the analytical method along with experimental observations on standard walls. These semi-empirical methods based on Equivalent Temperature Difference (**ETD**) or Cooling Load Temperature Difference (**CLTD**), are widely used by air conditioning industry due to their simplicity. However, the empirical data covers only standard walls and is suitable for specific location, orientation and day. In the present lecture, this method is used to estimate unsteady heat transfer through building walls and roofs. Before presenting this method, one has to consider the physical significance of decrement factor and time lag factor mentioned under analytical methods.

#### Decrement factor and Time Lag:

Based on the form suggested by analytical methods, the heat transfer rate to the conditioned space at any time  $\theta$  can be written as:

$$Q_{x=0,\theta} = UA(T_{\text{sol-air},m} - T_i) + UA\lambda(T_{\text{sol-air},\theta-\phi} - T_{\text{sol-air},m}) \quad (34.37)$$

In the above expression,  $T_{\text{sol-air},m}$  is the time averaged sol-air temperature,  $T_{\text{sol-air},\theta-\phi}$  is the sol-air temperature  $\phi$  hours before  $\theta$ ,  $U$  and  $A$  are the overall heat transfer coefficient and area of the wall,  $\lambda$  is the decrement factor and  $\phi$  is the time lag.

The **decrement factor**,  $\lambda$  accounts for the fact that due to finite thermal capacity, the heat transferred to the outer surface of the wall is partly stored and partly transferred to the conditioned space. Due to the thermal energy storage, the temperature of the wall increases, and if it exceeds the outdoor air temperature then a part of the energy stored is transferred to outside and not to the conditioned space. Thus finally the heat transferred to the conditioned space from the inner surface (**cooling load**) is smaller than the heat transferred to the outer surface. This implies that the finite thermal capacity of the wall introduces a decrement in heat transfer.

The decrement factor, that varies between 0 to 1, increases as the thermal capacity of the wall increases. Thus thicker walls have lower decrement factor and thinner walls have higher decrement factor.

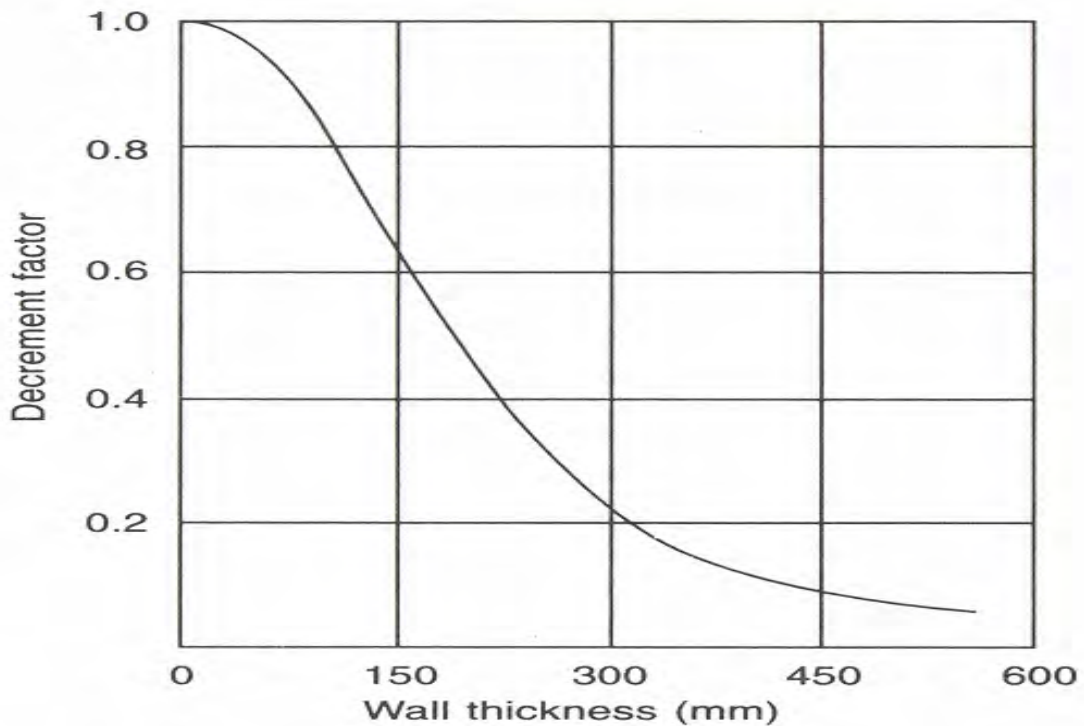
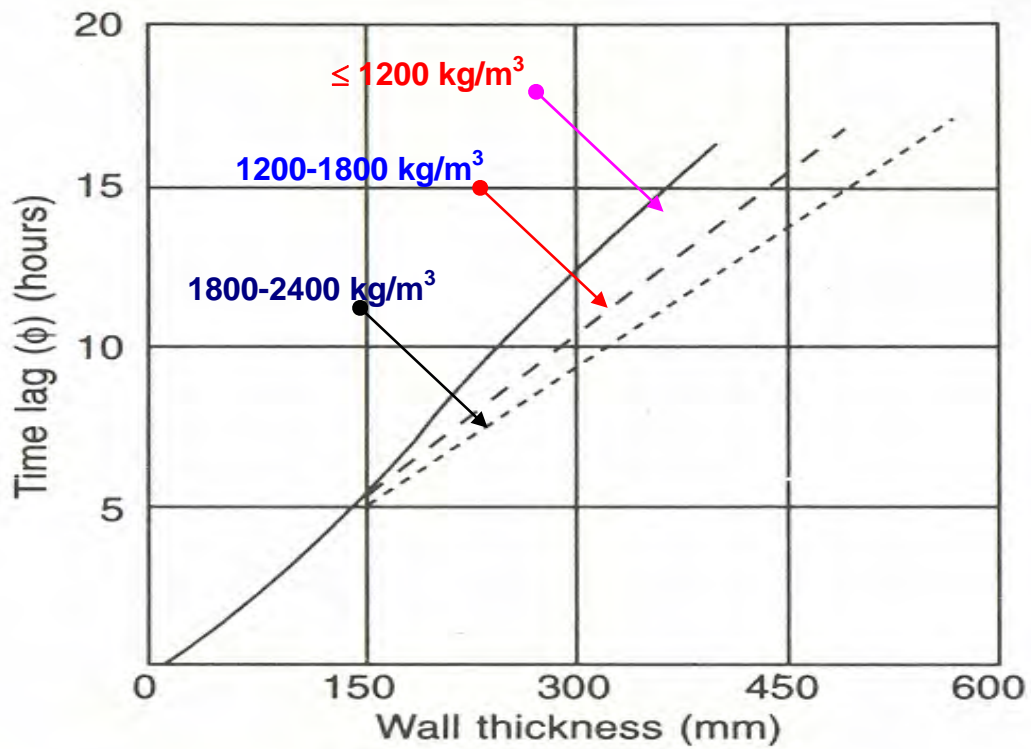
The finite thermal capacity of the building walls and roof also introduces a **time lag,  $\phi$** . The time lag is the difference between the time at which the outer surface receives heat and the time at which the inner surface senses it. Due to the effect of time lag, if the outdoor temperature is maximum at noon, the indoor temperature of a non-air conditioned room reaches a maximum somewhere in the afternoon.

As mentioned both decrement factor and time lag depend on the thermal capacity (**mass x specific heat**) of the wall. Most of the commonly used building structural materials have a specific heat of about 840 J/kg.K, then, the thermal capacity of these walls depend mainly on the thickness and density of the wall material. For these standard wall materials, the decrement factor decreases and the time lag increases as the wall thickness and density increase as shown in Fig. 34.6. Thus from the comfort point of view it is always advantageous to construct buildings with thick walls as this will yield low decrement factor and large time lag. In the limiting case, when the thermal capacity of the wall is very large, then the decrement factor becomes zero, then the heat transferred to the conditioned will remain constant throughout the day at the mean value as given by the Eqn.(34.37), i.e.,

$$Q_{x=0,\theta} = UA(T_{\text{sol-air,m}} - T_i) \quad \text{when } \lambda = 0.0 \quad (34.38)$$

On the other extreme, if the wall has negligible thermal capacity, then the decrement factor will be 1.0 and the time lag will be 0, and the heat transfer rate to the conditioned space at any point is equal to the heat transferred to the outer surface of the wall at that instant, i.e.,

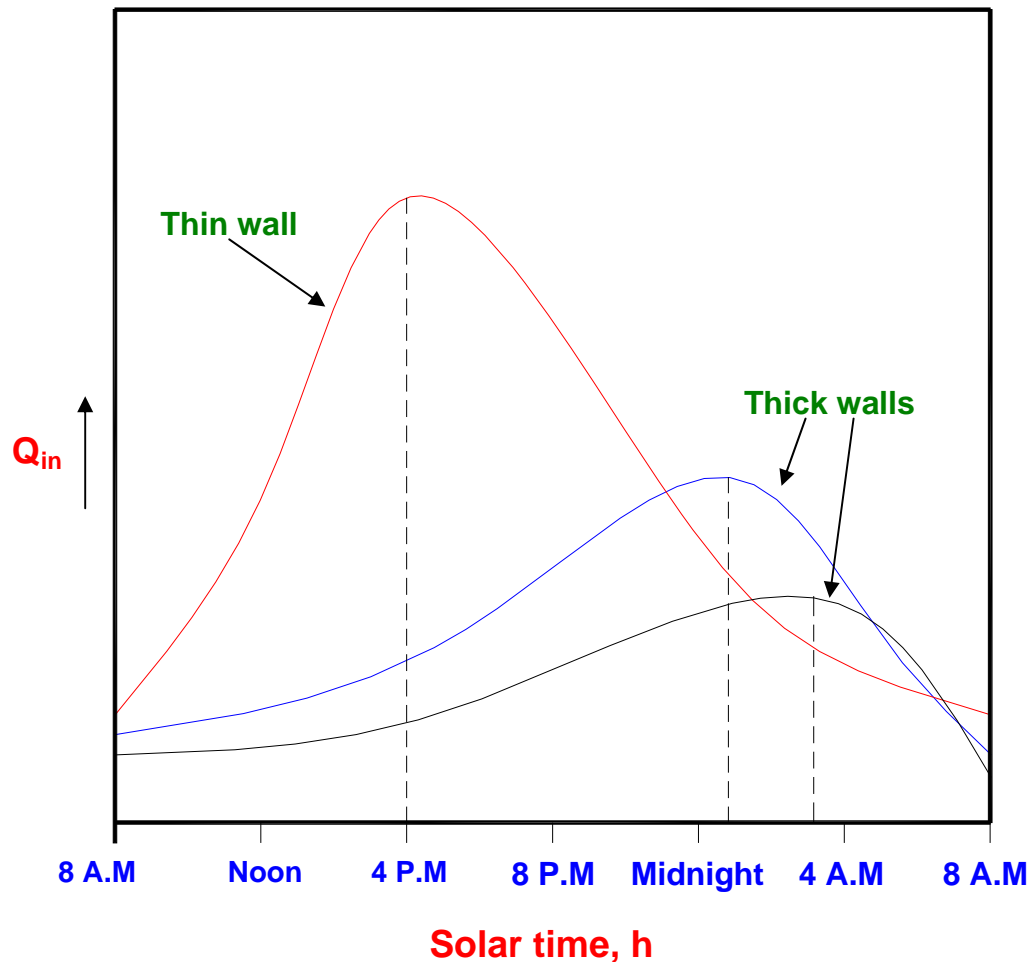
$$Q_{x=0,\theta} = UA(T_{\text{sol-air,\theta}} - T_i) \quad \text{when } \lambda = 1.0 \text{ and } \phi = 0 \quad (34.39)$$



**Fig.34.6:** Variation of time lag and decrement factor with wall thickness and density

In general the decrement factor of building walls and roof lies between 0 to 1 and the time lag will be greater than 0 hours. However, for windows and thin doors etc, which are exposed to outdoors, the decrement factor may be taken as 1.0 and the time lag factor as 0.0, as the thermal storage capacity of these elements is very small. Figure 34.7 shows the variation of heat transfer rate to the conditioned space with solar time for walls of different thickness. It can be seen that for thin walls with small time lag, the peak heat transfer occurs sometime around 4 P.M, whereas for thick walls with large time lags, the peak occurs well after midnight. Since the outside temperatures will be much smaller during the night the building can reject heat to the

outside during night, thus for thicker walls due to the thermal storage effect a major portion of the heat absorbed by the outer surface during the daytime can be rejected to the outside, while a relatively small amount is transferred to the conditioned space (small decrement factor). The net effect is a greatly reduced cooling load on the building for thick walls. It can also be observed that due to large decrement factor the peak heat transfer for thin walled structures is much higher compared to the thick walled buildings. This implies the requirement of cooling system of much larger capacity (hence high initial cost) for buildings with thin walls compared to thick walls.



**Fig.34.7:** Variation of heat transfer rate with time for thick and thin walled buildings

When the thermal capacity of the building is sufficiently large, then it is also possible to maintain reasonably comfortable temperatures inside the building even without an air conditioning system during both winter and summer. This is the principle behind old temples and buildings, which are comfortable throughout the year without any artificial air conditioning systems. However, the effect of the thermal capacity becomes significant mainly in locations, which have large variation in diurnal temperatures (i.e.,  $T_{\max} - T_{\min}$  on a particular day is large). This is generally the case in dry areas, where thick walled buildings are highly beneficial. In coastal areas with large humidity the diurnal temperature variation is not very large, as a result the decrement factor will be high even with thick walled buildings as the building cannot lose significant amount of heat to the outside even during the night due to the relatively high night temperatures. Thus thick walled buildings are not as effective in coastal areas as in dry areas.

## Empirical methods for cooling load estimation:

Equation (34.37) can be written as:

$$Q_{x=0,\theta} = UA(T_{\text{sol-air},m} - T_i) + UA\lambda(T_{\text{sol-air},\theta-\phi} - T_{\text{sol-air},m}) = UA \cdot \Delta T_{\text{eff}} \quad (34.40)$$

where  $\Delta T_{\text{eff}}$ , called as **Equivalent Temperature Difference (ETD)** or **Cooling Load Temperature Difference (CLTD)** is given by:

$$\Delta T_{\text{eff}} = (T_{\text{sol-air},m} - T_i) + \lambda(T_{\text{sol-air},\theta-\phi} - T_{\text{sol-air},m}) \quad (34.41)$$

It can be seen from the above expression that ETD or CLTD depends on:

- i. Decrement ( $\lambda$ ) and Time Lag ( $\phi$ ) factors
- ii. Solar radiation and outside ambient temperature (through sol-air temperature), and
- iii. Inside temperature,  $T_i$

Tables of ETD and CLTD have been prepared for fixed values of inside and outside temperatures, for different latitudes, orientations and different types of walls and roofs. For example, a typical CLTD table for a roof without suspended ceiling prepared and presented by ASHRAE is shown in Table 34.4:

Roof type	Mass per unit area, kg/m <sup>2</sup>	Heat capacity, kJ/m <sup>2</sup> .K	Solar Time, h													
			07	08	09	10	11	12	13	14	15	16	17	18	19	20
3	90	90	-2	1	5	11	18	25	31	36	39	40	40	37	32	25
4	150	120	1	0	2	4	8	13	18	24	29	33	35	36	35	32
5	250	230	4	4	6	8	11	15	18	22	25	28	29	30	29	27
6	365	330	9	8	7	8	8	10	12	15	18	20	22	24	25	26

**Description of Roof types:**

**Type 3:** 100 mm thick, lightweight concrete

**Type 4:** 150 mm thick, lightweight concrete

**Type 5:** 100 mm thick, heavyweight concrete

**Type 6:** Roof terrace systems

**Table 34.4:** CLTD values (in K) for flat roofs without suspended ceilings (ASHRAE Handbook)

For vertical walls in addition to the other parameters, the orientation of the wall affects the incident solar radiation and hence the CLTD values. For example, Table 34.5 shows the CLTD values for a D-Type (100-mm face brick with 200-mm concrete block and interior finish or 100-mm face brick and 100-mm concrete brick with interior finish) wall with solar time for different orientations:

Solar Time,h	Orientation							
	N	NE	E	SE	S	SW	W	NW
7	3	4	5	5	4	6	7	6
8	3	4	5	5	4	5	6	5
9	3	6	7	5	3	5	5	4
10	3	8	10	7	3	4	5	4
11	4	10	13	10	4	4	5	4
12	4	11	15	12	5	5	5	4
13	5	12	17	14	7	6	6	5
14	6	13	18	16	9	7	6	6
15	6	13	18	17	11	9	8	7
16	7	13	18	18	13	12	10	8
17	8	14	18	18	15	15	13	10
18	9	14	18	18	16	18	17	12
19	10	14	17	17	16	20	20	15
20	11	13	17	17	16	21	22	17
CLTD <sub>max</sub>	11	14	18	18	16	21	23	18

**Table 34.5:** CLTD values (in K) for D-type walls (ASHRAE Handbook)

The above tables are valid for the following conditions:

a) Inside temperature of **25°C**, maximum outside temperature of **35°C** with an average value of **29°C** and a daily range of **12°C**. For inside and average outside temperatures ( $T_i$  and  $T_{av}$ ) other than the above, the following adjustment has to be made to CLTD:

$$CLTD_{adj} = CLTD_{Table} + (25 - T_i) + (T_{av} - 29) \quad (34.42)$$

Where  $CLTD_{Table}$  is the value obtained from the table.

b) Solar radiation typical of July 21<sup>st</sup> at 40°N latitude, but in the absence of more accurate data, the tables can be used without significant error for 0°N to 50°N and for summer months.

Similar data are available for other types of walls and roofs and for different latitudes. Adjustments are also suggested for walls and roofs with insulation, wetted roofs etc.

Thus knowing the value of the overall heat transfer coefficient and area of the wall from the building specifications, local design outdoor temperatures and suitable ETD or CLTD values from the tables, one can calculate the heat transfer rate to the conditioned space through the opaque walls and roof of the building using Eq.(34.40). It should be remembered that the use of published ETD or CLTD cannot cover all possible walls and roofs and other conditions. Hence, some error is always involved in using these data. However, by developing individual heat transfer models for the specific building and using the numerical methods, one can estimate the heat transfer rate to the building more accurately. However, since this is extremely time consuming, practising engineers generally use the published data and provide a safety factor to account for possible differences in the actual and published values.



## Questions and answers:

1. Estimation of heat transfer rate through buildings is complex due to:

- a) Complex structure of the walls and roofs consisting of a wide variety of materials
- b) Varying indoor and outdoor conditions
- c) Large size of the buildings
- d) All of the above

**Ans.: a) and b)**

2. Heat transfer through buildings can be considered as steady, if:

- a) Variation in outdoor conditions with time are not significant
- b) Variation in indoor conditions with time are not significant
- c) Thermal capacity of the building is large
- d) All of the above

**Ans.: d)**

3. Which of the following statements are TRUE?

- a) A wall is said to be homogeneous if its properties do not vary with temperature
- b) A wall is said to be homogeneous if its properties do not vary with location
- c) The heat transfer resistance of a homogeneous wall depends on its thickness and density
- d) The heat transfer resistance of a homogeneous wall depends on its thickness and thermal conductivity

**Ans.: b) and d)**

4. Which of the following statements are TRUE?

- a) Heat transfer can take place by more than one mode in a non-homogeneous wall
- b) The heat transfer resistance of a non-homogeneous wall is indicated in terms of its conductance
- c) In an air space, the conduction effect becomes dominant as the air gap reduces
- d) In an air space, the conduction effect becomes dominant as the air gap increases

**Ans.: a), b) and c)**

5. Which of the following statements are TRUE?

- a) Heat transfer through a building wall may be considered as steady if its thermal capacity is very small
- b) When the thermal capacity of the wall is large, at any point of time the heat transferred to the outer surface of the wall is larger than the heat transfer from the inner surface
- c) When the thermal capacity of the wall is large, the heat transfer rate at the outer surface of the wall can be smaller than the heat transfer rate from the inner surface

d) Due to finite thermal capacity of the wall, the outer surface temperature is always higher than the inner surface temperature

**Ans.: c)**

**6.** Which of the following statements are TRUE?

- a) The sol-air temperature depends on indoor and outdoor temperatures
- b) The sol-air temperature depends on outdoor temperature and incident solar radiation
- c) The sol-air temperature depends on outdoor temperature, incident solar radiation and surface properties of the wall
- d) The sol-air temperature depends on outdoor temperature, incident solar radiation, surface properties of the wall and the external heat transfer coefficient

**Ans.: d)**

**7.** Which of the following statements are TRUE?

- a) In the analytical method, the outer boundary conditions are generally assumed to be independent of time
- b) In the analytical method, the outer boundary conditions are generally assumed to vary in a periodic manner with time
- c) In the analytical method, the indoor temperature is generally assumed to be independent of time
- d) Analytical methods are amenable to simple geometries only

**Ans.: b), c) and d)**

**8.** Which of the following statements are TRUE?

- a) For walls with negligible thermal capacity, the decrement factor is 0.0 and time lag is 1.0
- b) For walls with negligible thermal capacity, the decrement factor is 1.0 and time lag is 0.0
- c) The required cooling capacity of the air conditioning plant increases as decrement factor increases and time lag decreases
- d) The required cooling capacity of the air conditioning plant increases as decrement factor decreases and time lag increases

**Ans.: b) and c)**

**9.** Which of the following statements are TRUE?

- a) From thermal comfort point of view, thick walled structures are beneficial in hot and humid climates
- b) From thermal comfort point of view, thick walled structures are beneficial in hot and dry climates
- c) On a given day, the CLTD value of east facing wall reaches a peak before a west facing wall
- d) On a given day, the CLTD value of west facing wall reaches a peak before a east facing wall

**Ans.: b) and c)**

10. Which of the following statements are TRUE?

- a) Adjustments to CLTD tables have to be made if the latitude is different
- b) Adjustments to CLTD tables have to be made if the indoor temperature is different
- c) Adjustments to CLTD tables have to be made if the outdoor temperature is different
- d) Adjustments to CLTD tables have to be made if the daily range is different

**Ans.: b), c) and d)**

11. A building has to be maintained at 21°C(dry bulb) and 50% relative humidity when the outside conditions are -30°C(dry bulb) and 100% relative humidity. The inner and outer surface heat transfer coefficients are 8.3 W/m<sup>2</sup>.K and 34.4 W/m<sup>2</sup>.K, respectively. A designer chooses an insulated wall that has a thermal resistance (R-value) of 0.3 m<sup>2</sup>.K/W. Find whether the wall insulation is sufficient to prevent condensation of moisture on the surface. If the chosen R-value of the wall can lead to condensation, what is the minimum thickness of additional insulation (thermal conductivity 0.036 W/m.K) required to prevent condensation. Take the barometric pressure as 101 kPa.

**Ans.:** From the psychrometric chart; for inside conditions of 21°C and 50% RH:

$$\text{Dew Point Temperature, } T_{DPT,i} = 10^{\circ}\text{C}$$

The overall heat transfer coefficient for the wall U is given by:

$$U = [R_{\text{wall}} + (1/h_i) + (1/h_o)]^{-1} = [0.3 + (1/8.3) + (1/34.4)]^{-1} = 2.224 \text{ W/m}^2.\text{K}$$

Assuming steady state, the heat transfer rate through the wall is given by:

$$q_w = U(T_i - T_o) = 2.224 \times (21 - (-30)) = 113.424 \text{ W/m}^2$$

The temperature of the inner surface of the wall, T<sub>s,i</sub> is obtained using the equation:

$$q_w = h_i(T_i - T_{s,i}) = 113.424 \Rightarrow T_{s,i} = 7.33^{\circ}\text{C}$$

$$\text{Since } T_{s,i} < T_{DPT,i}$$

**⇒ Condensation will take place on the inner surface of the wall (Ans.)**

To prevent condensation, the minimum allowable temperature of inner surface is the DPT (10°C)

Under this condition, the maximum allowable heat transfer rate is given by:

$$q_{w,\text{allowable}} = h_i(T_i - T_{DPT,i}) = 8.3 \times (21 - 10) = 91.3 \text{ W/m}^2$$

Hence the required U<sub>req</sub> value is:

$$U_{\text{req}} = 91.3/(T_i - T_o) = 91.3/(21 - (-30)) = 1.79 \text{ W/m}^2.\text{K}$$

Hence the required resistance of the wall, R<sub>w,req</sub> is given by:

$$R_{w,req} = (1/U_{req}) - (1/h_i) - (1/h_o) = 0.4091 \text{ m}^2.\text{K/W}$$

Hence the amount of additional insulation to be added is:

$$R_{add} = (t_{add}/k_{add}) = 0.4091 - R_{wall} = 0.4091 - 0.3 = 0.1091 \text{ m}^2.\text{K/W}$$

⇒ Required insulation thickness,  $t_{add} = 0.1091 \times 0.036 = 3.928 \times 10^{-3} \text{ m}$  (Ans.)

**12.** A 4m x 5m wall consists of 3 glass windows of 1.5m x 1.0 m dimensions. The wall has thickness of 0.125 m and a thermal conductivity of 0.5 W/m.K, while the glass windows are 6 mm thick with a thermal conductivity of 1.24 W/m.K. The values of internal and external surface conductance for the wall (including glass) are 8.3 W/m<sup>2</sup>.K and 34.4 W/m<sup>2</sup>.K, respectively. The internal and external temperatures are 21°C and -30°C, respectively. Calculate the total heat transfer rate through the wall. What percentage of this heat transfer is through the windows?

**Ans.:** The total heat transfer rate through the wall is given by:

$$Q_{total} = U_o A_{total} (T_i - T_o)$$

The value of  $U_o A_{total}$  is given by:

$$U_o A_{total} = U_{wall} A_{wall} + U_{glass} A_{glass}$$

The U values for the wall and glass are obtained from their individual resistance values as:

$$U_{wall} = [(0.125/0.5) + (1/8.3) + (1/34.4)]^{-1} = 2.503 \text{ W/m}^2.\text{K}$$

$$U_{glass} = [(0.006/1.24) + (1/8.3) + (1/34.4)]^{-1} = 6.48 \text{ W/m}^2.\text{K}$$

$$\text{The area of glass, } A_{glass} = 3 \times 1.5 \times 1.0 = 4.5 \text{ m}^2$$

$$\text{The area of wall, } A_{wall} = 4 \times 5 - 4.5 = 15.5 \text{ m}^2$$

$$\text{Hence, } U_o A_{total} = U_{wall} A_{wall} + U_{glass} A_{glass} = 2.503 \times 15.5 + 6.48 \times 4.5 = 67.96 \text{ W/K}$$

$$\text{Hence, } Q_{total} = U_o A_{total} (T_i - T_o) = 67.96 (21 + 30) = 3465.96 \text{ W} \quad (\text{Ans.})$$

$$\% \text{ of heat transfer rate through glass} = \{U_{glass} A_{glass} (T_i - T_o) / Q_{total}\} \times 100 = 42.9\% \quad (\text{Ans.})$$

**13.** A multi-layered wall consists (from inside to outside) 6mm thick plywood, 125 mm thick common brick, 2.1 mm thick air space, 125 mm thick common brick and 6 mm thick cement plaster. The values of internal and external surface conductance for the wall are 8.3 W/m<sup>2</sup>.K and 34.4 W/m<sup>2</sup>.K, respectively. Find the overall heat transfer coefficient of the wall. What is the value of U, if the air space is replaced by 20 mm thick EPS board? Assume the temperature difference across the air space to be 10 K.

**Ans.:** For the composite wall, the overall heat transfer coefficient U is given by:

$$\left(\frac{1}{U}\right) = R_{\text{tot}} = \left(\frac{1}{h_i}\right) + \sum_{i=1}^N \left(\frac{\Delta x_i}{k_{w,i}}\right) + \sum_{j=1}^M \left(\frac{1}{C_j}\right) + \left(\frac{1}{h_o}\right)$$

Substituting the values of individual resistances using the input values of wall thickness and thermal conductivity and thermal conductance (From Tables 34.2 and 34.3), the overall heat transfer coefficient is given by:

$$\left(\frac{1}{U}\right) = \left(\frac{1}{8.3}\right) + \left(\frac{0.006}{0.1}\right) + \left(\frac{0.125}{0.77}\right) + \left(\frac{1}{5.8}\right) + \left(\frac{0.125}{0.77}\right) + \left(\frac{0.006}{8.65}\right) + \left(\frac{1}{34.4}\right) = 0.7073 \text{ m}^2\text{K/W}$$

$$\Rightarrow U = 1.414 \text{ W/m}^2\text{.K} \quad (\text{Ans.})$$

If the air space is replaced by 20 mm EPS ( $k = 0.037 \text{ W/m.K}$ ), then the new U-value is:

$$U_{\text{EPS}} = [(1/U) - (1/5.8) + (0.02/0.037)]^{-1} = 0.93 \text{ W/m}^2\text{.K} \quad (\text{Ans.})$$

Thus replacing the air gap with EPS leads to a **decrease in the U-value by about 34 percent.**

**14.** Determine the sol-air temperature for a flat roof if the direct radiation normal to the sun's rays ( $I_{\text{DN}}$ ) is  $893 \text{ W/m}^2$  and the intensity of scattered radiation normal to the roof ( $I_d$ ) is  $112 \text{ W/m}^2$ . Take the absorptivity of the roof for direct and scattered radiation as 0.9, the heat transfer coefficient of the outside surface as  $34.4 \text{ W/m}^2$ , the outside air temperature as  $37^\circ\text{C}$  and the solar altitude angle as  $80^\circ$ . If the time lag of the roof structure is zero and its decrement factor is unity, calculate the heat gain to the room beneath the roof if the U-value of the roof is  $0.5 \text{ W/m}^2\text{.K}$  and the room temperature is  $25^\circ\text{C}$ .

**Ans.:** For a flat roof, the angle of incidence  $\theta$  is given by:

$$\theta = (\pi/2) - \beta = (\pi/2) - 80 = 10^\circ$$

where  $\beta$  is the altitude angle

Total solar irradiation on the flat roof  $I_t$  is given by:

$$I_t = I_{\text{DN}} \cdot \cos(\theta) + I_d = 893 \times \cos(10) + 112 = 991.43 \text{ W/m}^2$$

Hence the sol-air temperature is given by:

$$T_{\text{sol-air}} = T_o + \left(\frac{\alpha_D I_D + \alpha_d I_d - R}{h_o}\right) = 37 + \frac{0.9 \times 991.43}{34.4} = 62.94^\circ \quad (\text{Ans.})$$

Since the time lag is 0 and decrement factor is 1.0 for the roof, the heat transfer rate through the roof is given by:

$$q = U(T_{\text{sol-air}} - T_i) = 18.97 \text{ W/m}^2 \quad (\text{Ans.})$$

**15.** A building has its north, west facing walls and the roof exposed to sun. The dimensions of the building are 12 m X 12 m X 5 m (WXLXH). The U-value of the walls are 0.5 W/m<sup>2</sup>.K, while it is 0.4 W/m<sup>2</sup>.K for the roof. There are no windows on north and west walls, and the other two walls are exposed to air conditioned spaces. The outside design temperature is 41°C while the indoor is maintained at 25°C, while the average temperature for the design day is 31°C. Calculate heat transfer rate to the building at 5 P.M., 6 P.M. and 7 P.M. Assume the walls are of D-Type and the roof is of Type 5.

Ans.: Since the average outside temperature is different from 29°C, adjustments have to be made to the values obtained from the CLTD tables.

$$\text{CLTD}_{\text{adj}} = \text{CLTD}_{\text{Table}} + (T_{\text{av}} - 29) = \text{CLTD}_{\text{Table}} + 2$$

a) Heat transfer rate through the roof:

From the Table of CLTD values for roof (Table 34.5), the CLTD values at 5 P.M., 6 P.M. and 7 P.M. are 29°C, 30°C and 29°C, respectively.

$$\therefore Q_{\text{roof}, 5 \text{ P.M.}} = U_{\text{roof}} A_{\text{roof}} \text{CLTD}_{\text{adj}, 5 \text{ P.M.}} = 0.4 \times 144 \times (29 + 2) = 1785.6 \text{ W}$$

$$Q_{\text{roof}, 6 \text{ P.M.}} = U_{\text{roof}} A_{\text{roof}} \text{CLTD}_{\text{adj}, 6 \text{ P.M.}} = 0.4 \times 144 \times 32 = 1843.2 \text{ W}$$

$$Q_{\text{roof}, 7 \text{ P.M.}} = Q_{\text{roof}, 5 \text{ P.M.}} = 1785.6 \text{ W (as the CLTD values are same)}$$

b) Heat transfer rate through north facing wall:

Table 34.6 is used for obtaining CLTD values for the walls

$$Q_{\text{north}, 5 \text{ P.M.}} = U_{\text{wall}} A_{\text{wall}} \text{CLTD}_{\text{adj}, 5 \text{ P.M.}} = 0.5 \times 60 \times 10 = 300 \text{ W}$$

$$Q_{\text{north}, 6 \text{ P.M.}} = U_{\text{wall}} A_{\text{wall}} \text{CLTD}_{\text{adj}, 6 \text{ P.M.}} = 0.5 \times 60 \times 11 = 330 \text{ W}$$

$$Q_{\text{north}, 7 \text{ P.M.}} = U_{\text{wall}} A_{\text{wall}} \text{CLTD}_{\text{adj}, 7 \text{ P.M.}} = 0.5 \times 60 \times 12 = 360 \text{ W}$$

c) Heat transfer rate through the west facing wall:

Similar to the north facing wall, the heat transfer rates through the west facing walls are found to be:

$$Q_{\text{west}, 5 \text{ P.M.}} = 450 \text{ W}$$

$$Q_{\text{west}, 6 \text{ P.M.}} = 570 \text{ W}$$

$$Q_{\text{west}, 7 \text{ P.M.}} = 660 \text{ W}$$

∴ Total heat transfer through the building is:

$$Q_{\text{total}, 5 \text{ P.M.}} = 1785.6 + 300 + 450 = 2535.6 \text{ W} \quad (\text{Ans.})$$

$$Q_{\text{total}, 6 \text{ P.M.}} = 1843.2 + 330 + 570 = 2743.2 \text{ W} \quad (\text{Ans.})$$

$$Q_{\text{total}, 7 \text{ P.M.}} = 1785.6 + 360 + 660 = 2805.6 \text{ W} \quad (\text{Ans.})$$

## Comments:

1. The difference in design dry bulb temperature between outdoor and indoor is  $17^{\circ}\text{C}$ , it is observed that the CLTD value ranges between  $31$  to  $32^{\circ}\text{C}$  for the roof,  $10$  to  $12^{\circ}\text{C}$  for the north facing the wall and  $15$  to  $22^{\circ}\text{C}$  for the west facing wall. The difference between CLTD values and  $(T_o - T_i)_{\text{design}}$  is due to varying outdoor temperatures, varying solar radiation and finally due to the thermal capacity of the walls.
2. It is seen that the maximum amount of heat transfer rate is through the roof, hence, putting additional insulation on the roof will reduce the cooling load
3. Due to the thermal lag effect of the building, the peak heat transfer takes place not during sunshine, but after sunset.

# Lesson

35

Cooling And Heating

Load Calculations

- Estimation Of Required

Cooling/Heating

Capacity



## The specific objectives of this chapter are to:

1. Introduction to load calculations (*Section 35.1*)
2. Differences between conventional cooling and heating load calculation methodologies (*Section 35.2*)
3. Methods of estimating cooling and heating loads on buildings such as rules-of-thumb, semi-empirical methods etc. (*Section 35.3*)
4. Cooling load calculations using CLTD/CLF method (*Section 35.4*)
5. Estimation of the cooling capacity of the system (*Section 35.5*)
6. Heating load calculations (*Section 35.6*)

At the end of the lecture, the student should be able to:

1. Explain the differences between conventional cooling and heating load calculations
2. List commonly used methods for estimating cooling loads
3. Estimate the internal and external cooling loads on a building by separating sensible and latent parts using CLTD/CLF method from building specifications, design indoor and outdoor conditions, occupancy etc.
4. Estimate the required cooling capacity of the coil by taking into account the bypass factor of the coil, ventilation requirements etc.
5. Explain briefly the procedure for estimating heating loads

### 35.1. Introduction:

As mentioned in an earlier chapter, heating and cooling load calculations are carried out to estimate the required capacity of heating and cooling systems, which can maintain the required conditions in the conditioned space. To estimate the required cooling or heating capacities, one has to have information regarding the design indoor and outdoor conditions, specifications of the building, specifications of the conditioned space (such as the occupancy, activity level, various appliances and equipment used etc.) and any special requirements of the particular application. For comfort applications, the required indoor conditions are fixed by the criterion of thermal comfort, while for industrial or commercial applications the required indoor conditions are fixed by the particular processes being performed or the products being stored. As discussed in an earlier chapter, the design outdoor conditions are chosen based on design dry bulb and coincident wet bulb temperatures for peak summer or winter months for cooling and heating load calculations, respectively.

## 35.2. Heating versus cooling load calculations:

As the name implies, **heating load calculations** are carried out to estimate the heat loss from the building in winter so as to arrive at required **heating capacities**. Normally during winter months the peak heating load occurs before sunrise and the outdoor conditions do not vary significantly throughout the winter season. In addition, internal heat sources such as occupants or appliances are beneficial as they compensate some of the heat losses. As a result, normally, the heat load calculations are carried out assuming steady state conditions (no solar radiation and steady outdoor conditions) and neglecting internal heat sources. This is a simple but conservative approach that leads to slight overestimation of the heating capacity. For more accurate estimation of heating loads, one has to take into the thermal capacity of the walls and internal heat sources, which makes the problem more complicated.

For estimating **cooling loads**, one has to consider the unsteady state processes, as the peak cooling load occurs during the day time and the outside conditions also vary significantly throughout the day due to solar radiation. In addition, all internal sources add on to the cooling loads and neglecting them would lead to underestimation of the required cooling capacity and the possibility of not being able to maintain the required indoor conditions. Thus cooling load calculations are inherently more complicated as it involves solving unsteady equations with unsteady boundary conditions and internal heat sources.

For any building there exists a **balance point** at which the solar radiation ( $Q_{\text{solar}}$ ) and internal heat generation rate ( $Q_{\text{int}}$ ) exactly balance the heat losses from the building. Thus from sensible heat balance equation, at balanced condition:

$$(Q_{\text{solar}} + Q_{\text{int}})_{\text{sensible}} = UA(T_{\text{in}} - T_{\text{out}}) \quad (35.1)$$

where  $UA$  is the product of overall heat transfer coefficient and heat transfer area of the building,  $T_{\text{in}}$  is the required indoor temperature and  $T_{\text{out}}$  is the outdoor temperature.

From the above equation, the outside temperature at balanced condition ( $T_{\text{out,bal}}$ ) is given by:

$$T_{\text{out,bal}} = T_{\text{in}} - \frac{(Q_{\text{solar}} + Q_{\text{int}})_{\text{sensible}}}{UA} \quad (35.2)$$

If the outdoor temperature is greater than the balanced outdoor temperature given by the above equation, i.e., when  $T_{\text{out}} > T_{\text{out,bal}}$ , then there is a **need for cooling** the building. On the other hand, when the outdoor temperature is less than the balanced outdoor temperature, i.e., when  $T_{\text{out}} < T_{\text{out,bal}}$ , then there is a **need for heating** the building. When the outdoor temperature exactly equals the balanced outdoor temperature, i.e., when  $T_{\text{out}} = T_{\text{out,bal}}$ , then there is **no need for either cooling or heating** the building

For residential buildings (with fewer internal heat sources), the balanced outdoor temperature may vary from 10 to 18°C. As discussed before, this means that if the balanced outdoor temperature is 18°C, then a cooling system is required when the outdoor temperature exceeds 18°C. This implies that buildings need cooling not only during summer but also during spring and fall as well. If the building is well insulated (small UA) and/or internal loads are high, then from the energy balance equation (35.2), the balanced outdoor temperature will reduce leading to extended cooling season and shortened heating season. Thus a smaller balanced outdoor temperature implies higher cooling requirements and smaller heating requirements, and vice versa. For commercial buildings with large internal loads and relatively smaller heat transfer areas, the balanced outdoor temperature can be as low as 2°C, implying a lengthy cooling season and a small heating season. If there are no internal heat sources and if the solar radiation is negligible, then from the heat balance equation,  $T_{out,bal} = T_{in}$ , this implies that if the outside temperature exceeds the required inside temperature (say, 25°C for comfort) then there is a need for cooling otherwise there is a need for heating. Thus depending upon the specific conditions of the building, the need for either cooling system or a heating system depends. This also implies a need for optimizing the building insulation depending upon outdoor conditions and building heat generation so that one can use during certain periods free cooling provided by the environment without using any external cooling system.

### 35.3. Methods of estimating cooling and heating loads:

Generally, heating and cooling load calculations **involve a systematic, stepwise procedure**, using which one can arrive at the required system capacity by taking into account all the building energy flows. In practice, a variety of methods ranging from simple rules-of-thumb to complex Transfer Function Methods are used in practice to arrive at the building loads. For example, typical rules-of-thumb methods for cooling loads specify the required cooling capacity based on the floor area or occupancy. Table 35.1 shows typical data on required cooling capacities based on the floor area or application. Such rules-of-thumb are useful in preliminary estimation of the equipment size and cost. The main conceptual drawback of rules-of-thumb methods is the presumption that the building design will not make any difference. Thus the rules for a badly designed building are typically the same as for a good design.

Sl.no	Application	Required cooling capacity (TR) for 1000 ft <sup>2</sup> of floor area
1.	<b>Office buildings:</b> External zones	<u>25% glass:</u> 3.5 TR <u>50% glass:</u> 4.5 TR <u>75% glass:</u> 5.0 TR
	Internal zones	2.8 TR
2.	<b>Computer rooms</b>	6.0 – 12.0 TR
3.	<b>Hotels</b> Bedrooms	<u>Single room:</u> 0.6 TR per room <u>Double room:</u> 1.0 TR per room
	Restaurants	5.0 - 9.0 TR
4.	<b>Department stores</b> Basement & ground floors	4.5 – 5.0 TR
	Upper floors	3.5 – 4.5 TR
5.	<b>Shops</b>	5.0 TR
6.	<b>Banks</b>	4.5 – 5.5 TR
7.	<b>Theatres &amp; Auditoriums</b>	0.07 TR per seat

*Table 35.1: Required cooling capacities for various applications based on rules-of-thumb (Croome and Roberts, 1981)*

More accurate load estimation methods involve a combination of analytical methods and empirical results obtained from actual data, for example the use of Cooling Load Temperature Difference (**CLTD**) for estimating fabric heat gain and the use of Solar Heat Gain Factor (**SHGF**) for estimating heat transfer through fenestration. These methods are very widely used by air conditioning engineers as they yield reasonably accurate results and estimations can be carried out manually in a relatively short time. Over the years, more accurate methods that require the use of computers have been developed for estimating cooling loads, e.g. the **Transfer Function Method** (TFM). Since these methods are expensive and time consuming they are generally used for estimating cooling loads of large commercial or institutional buildings. ASHRAE suggests different methods for estimating cooling and heating loads based on applications, such as for residences, for commercial buildings etc.

## 35.4. Cooling load calculations:

As mentioned before, load calculations involve a systematic and stepwise procedure that takes into account all the relevant building energy flows. The cooling load experienced by a building varies in magnitude from zero (no cooling required) to a maximum value. The design cooling load is a load near the maximum magnitude, but is not normally the maximum. Design cooling load takes into account all the loads experienced by a building under a specific set of assumed conditions.

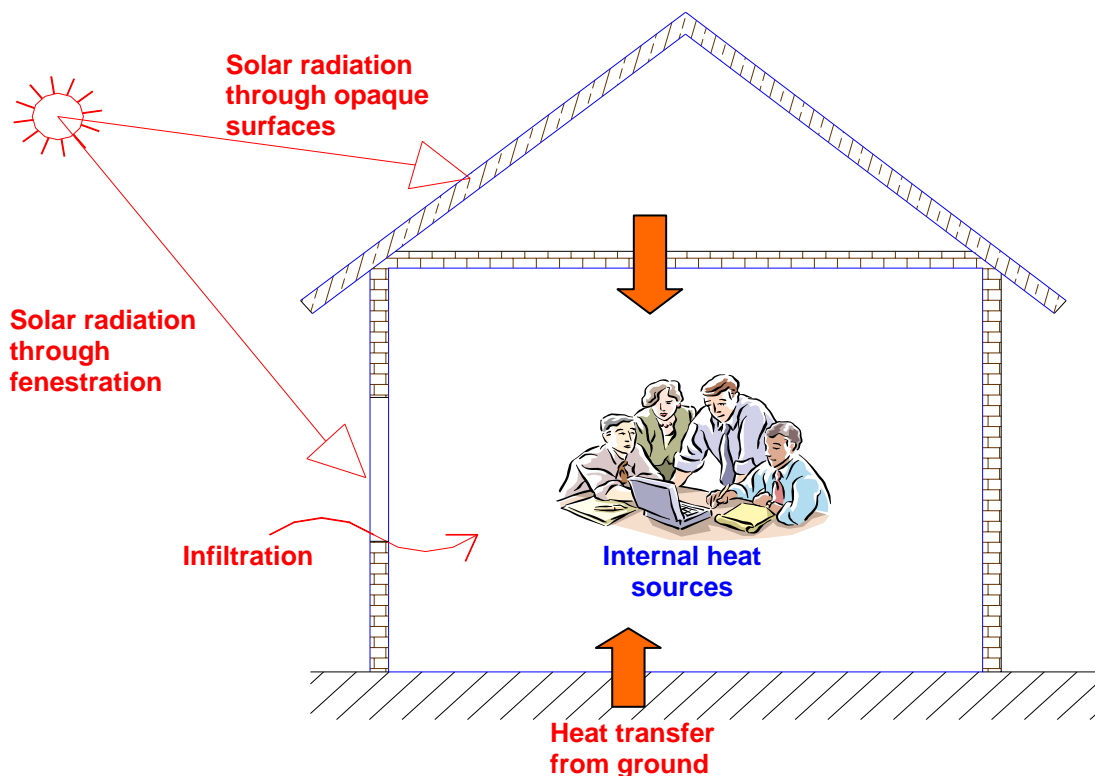
The assumptions behind design cooling load are as follows:

1. Design outside conditions are selected from a long-term statistical database. The conditions will not necessarily represent any actual year, but are representative of the location of the building. Design data for outside conditions for various locations of the world have been collected and are available in tabular form in various handbooks.
2. The load on the building due to solar radiation is estimated for clear sky conditions.
3. The building *occupancy* is assumed to be *at full design capacity*.
4. All building equipment and appliances are considered to be operating at a reasonably representative capacity.

The total building cooling load consists of heat transferred through the building envelope (walls, roof, floor, windows, doors etc.) and heat generated by occupants, equipment, and lights. The load due to heat transfer through the envelope is called as **external load**, while all other loads are called as **internal loads**. The percentage of external versus internal load varies with building type, site climate, and building design. The total cooling load on any building consists of both **sensible** as well as **latent** load components. The sensible load affects dry bulb temperature, while the latent load affects the moisture content of the conditioned space.

Buildings may be classified as **externally loaded and internally loaded**. In externally loaded buildings the cooling load on the building is mainly due to heat transfer between the surroundings and the internal conditioned space. Since the surrounding conditions are highly variable in any given day, the **cooling load of an externally loaded building varies widely**. In internally loaded buildings the cooling load is mainly due to internal heat generating sources such as occupants or appliances or processes. In general the heat generation due to internal heat sources may remain fairly constant, and since the heat transfer from the variable surroundings is much less compared to the internal heat sources, the **cooling load of an internally loaded building remains fairly constant**. Obviously from energy efficiency and economics points of view, the system design strategy for an externally loaded building should be different from an internally loaded building. Hence, prior knowledge of whether the building is externally loaded or internally loaded is essential for effective system design.

As mentioned before, the total cooling load on a building consists of external as well as internal loads. The external loads consist of heat transfer by conduction through the building walls, roof, floor, doors etc, heat transfer by radiation through fenestration such as windows and skylights. All these are sensible heat transfers. In addition to these the external load also consists of heat transfer due to infiltration, which consists of both sensible as well as latent components. The heat transfer due to ventilation is not a load on the building but a load on the system. The various internal loads consist of sensible and latent heat transfer due to occupants, products, processes and appliances, sensible heat transfer due to lighting and other equipment. Figure 35.1 shows various components that constitute the cooling load on a building.



**Fig.35.1:** Various cooling load components

Estimation of cooling load involves estimation of each of the above components from the given data. In the present chapter, the cooling load calculations are carried out based on the CLTD/CLF method suggested by ASHRAE. For more advanced methods such as TFM, the reader should refer to ASHRAE and other handbooks.

### 35.4.1. Estimation of external loads:

a) Heat transfer through opaque surfaces: This is a sensible heat transfer process. The heat transfer rate through opaque surfaces such as walls, roof, floor, doors etc. is given by:

$$Q_{\text{opaque}} = U.A.CLTD \quad (35.3)$$

where  $U$  is the overall heat transfer coefficient and  $A$  is the heat transfer area of the surface on the side of the conditioned space. CLTD is the cooling load temperature difference.

**For sunlit surfaces**, CLTD has to be obtained **from the CLTD tables** as discussed in the previous chapter. Adjustment to the values obtained from the table is needed if actual conditions are different from those based on which the CLTD tables are prepared.

**For surfaces which are not sunlit or which have negligible thermal mass** (such as doors), the CLTD value is simply equal to the **temperature difference across the wall or roof**. For example, for external doors the CLTD value is simply equal to the difference between the design outdoor and indoor dry bulb temperatures,  $T_{out}-T_{in}$ .

For **interior air conditioned rooms surrounded by non-air conditioned spaces**, the CLTD of the interior walls is equal to the temperature difference between the surrounding non-air conditioned space and the conditioned space. Obviously, if an air conditioned room is surrounded by other air conditioned rooms, with all of them at the same temperature, the CLTD values of the walls of the interior room will be zero.

Estimation of **CLTD values of floor and roof with false ceiling** could be tricky. For floors standing on ground, one has to use the temperature of the ground for estimating CLTD. However, the ground temperature depends on the location and varies with time. ASHRAE suggests suitable temperature difference values for estimating heat transfer through ground. If the floor stands on a basement or on the roof of another room, then the CLTD values for the floor are the temperature difference across the floor (i.e., difference between the temperature of the basement or room below and the conditioned space). This discussion also holds good for roofs which have non-air conditioned rooms above them. For **sunlit roofs with false ceiling**, the  $U$  value may be obtained by assuming the false ceiling to be an air space. However, the CLTD values obtained from the tables may not exactly fit the specific roof. Then one has to use his judgement and select suitable CLTD values.

**b) Heat transfer through fenestration:** Heat transfer through transparent surface such as a window, includes heat transfer by conduction due to temperature difference across the window and heat transfer due to solar radiation through the window. The heat transfer through the window by convection is calculated using Eq.(35.3), with CLTD being equal to the temperature difference across the window and  $A$  equal to the total area of the window. The heat transfer due to solar radiation through the window is given by:

$$Q_{trans} = A_{unshaded} \cdot SHGF_{max} \cdot SC \cdot CLF \quad (35.4)$$

where  $A_{unshaded}$  is the area exposed to solar radiation,  $SHGF_{max}$  and  $SC$  are the maximum Solar Heat Gain Factor and Shading Coefficient, respectively, and **CLF** is the **Cooling Load Factor**. As discussed in a previous chapter, the unshaded area has to be obtained from the dimensions of the external shade and solar geometry.  $SHGF_{max}$  and  $SC$  are obtained from ASHRAE tables based on the orientation of the window, location, month of the year and the type of glass and internal shading device.

The **Cooling Load Factor (CLF)** accounts for the fact that all the radiant energy that enters the conditioned space at a particular time does not become a part of the cooling load<sup>1</sup> instantly. As solar radiation enters the conditioned space, only a negligible portion of it is absorbed by the air particles in the conditioned space instantaneously leading to a minute change in its temperature. Most of the radiation is first absorbed by the internal surfaces, which include ceiling, floor, internal walls, furniture etc. Due to the large but finite thermal capacity of the roof, floor, walls etc., their temperature increases slowly due to absorption of solar radiation. As the surface temperature increases, heat transfer takes place between these surfaces and the air in the conditioned space. Depending upon the thermal capacity of the wall and the outside temperature, some of the absorbed energy due to solar radiation may be conducted to the outer surface and may be lost to the outdoors. Only that fraction of the solar radiation that is transferred to the air in the conditioned space becomes a load on the building, the heat transferred to the outside is not a part of the cooling load. Thus it can be seen that the **radiation heat transfer introduces a time lag and also a decrement factor** depending upon the dynamic characteristics of the surfaces. Due to the time lag, the effect of radiation will be felt even when the source of radiation, in this case the sun is removed. The CLF values for various surfaces have been calculated as functions of solar time and orientation and are available in the form of tables in ASHRAE Handbooks. Table 35.2 gives typical CLF values for glass with interior shading.

Solar Time, h	Direction the sunlit window is facing								
	N	NE	E	SE	S	SW	W	NW	Horiz.
6	0.73	0.56	0.47	0.30	0.09	0.07	0.06	0.07	0.12
7	0.66	0.76	0.72	0.57	0.16	0.11	0.09	0.11	0.27
8	0.65	0.74	0.80	0.74	0.23	0.14	0.11	0.14	0.44
9	0.73	0.58	0.76	0.81	0.38	0.16	0.13	0.17	0.59
10	0.80	0.37	0.62	0.79	0.58	0.19	0.15	0.19	0.72
11	0.86	0.29	0.41	0.68	0.75	0.22	0.16	0.20	0.81
12	0.89	0.27	0.27	0.49	0.83	0.38	0.17	0.21	0.85
13	0.89	0.26	0.26	0.33	0.80	0.59	0.31	0.22	0.85
14	0.86	0.24	0.24	0.28	0.68	0.75	0.53	0.30	0.81
15	0.82	0.22	0.22	0.25	0.50	0.83	0.72	0.52	0.71
16	0.75	0.20	0.20	0.22	0.35	0.81	0.82	0.73	0.58
17	0.78	0.16	0.16	0.18	0.27	0.69	0.81	0.82	0.42
18	0.91	0.12	0.12	0.13	0.19	0.45	0.61	0.69	0.25

**Table 35.2:** Cooling Load Factor (CLF) for glass with interior shading and located in north latitudes (ASHRAE)

**c) Heat transfer due to infiltration:** Heat transfer due to infiltration consists of both sensible as well as latent components. The sensible heat transfer rate due to infiltration is given by:

<sup>1</sup> At any point of time, cooling load may be equated to the heat transfer rate to the air in the conditioned space. If heat is transferred to the walls or other solid objects, then it does not become a part of the cooling load at that instant



$$Q_{s,inf} = \dot{m}_o c_{p,m} (T_o - T_i) = \dot{V}_o \rho_o c_{p,m} (T_o - T_i) \quad (35.5)$$

where  $\dot{V}_o$  is the infiltration rate ( in  $m^3/s$ ),  $\rho_o$  and  $c_{p,m}$  are the density and specific heat of the moist, infiltrated air, respectively.  $T_o$  and  $T_i$  are the outdoor and indoor dry bulb temperatures.

The latent heat transfer rate due to infiltration is given by:

$$Q_{l,inf} = \dot{m}_o h_{fg} (W_o - W_i) = \dot{V}_o \rho_o h_{fg} (W_o - W_i) \quad (35.6)$$

where  $h_{fg}$  is the latent heat of vaporization of water,  $W_o$  and  $W_i$  are the outdoor and indoor humidity ratio, respectively.

As discussed in an earlier chapter, the infiltration rate depends upon several factors such as the tightness of the building that includes the walls, windows, doors etc and the prevailing wind speed and direction. As mentioned before, the infiltration rate is obtained by using either the air change method or the crack method.

The infiltration rate by air change method is given by:

$$\dot{V}_o = (ACH).V / 3600 \quad m^3 / s \quad (35.7)$$

where **ACH is the number of air changes per hour** and **V is the gross volume of the conditioned space** in  $m^3$ . Normally the ACH value varies from 0.5 ACH for tight and well-sealed buildings to about 2.0 for loose and poorly sealed buildings. For modern buildings the ACH value may be as low as 0.2 ACH. Thus depending upon the age and condition of the building an appropriate ACH value has to be chose, using which the infiltration rate can be calculated.

The infiltration rate by the crack method is given by:

$$\dot{V}_o = A.C.\Delta P^n \quad m^3 / s \quad (35.8)$$

where **A is the effective leakage area of the cracks**, **C is a flow coefficient** which depends on the type of the crack and the nature of the flow in the crack,  **$\Delta P$  is the difference between outside and inside pressure ( $P_o - P_i$ )** and **n is an exponent** whose value depends on the nature of the flow in the crack. The value of n varies between 0.4 to 1.0, i.e.,  $0.4 \leq n \leq 1.0$ . The pressure difference  **$\Delta P$**  arises due to pressure difference due to the wind ( **$\Delta P_{wind}$** ), pressure difference due to the stack effect ( **$\Delta P_{stack}$** ) and pressure difference due to building pressurization ( **$\Delta P_{bld}$** ), i.e.,

$$\Delta P = \Delta P_{wind} + \Delta P_{stack} + \Delta P_{bld} \quad (35.9)$$

Semi-empirical expressions have been obtained for evaluating pressure difference due to wind and stack effects as functions of prevailing wind velocity and direction, inside and outside temperatures, building dimensions and geometry etc.

Representative values of infiltration rate for different types of windows, doors walls etc. have been measured and are available in tabular form in air conditioning design handbooks.

**d) Miscellaneous external loads:** In addition to the above loads, if the cooling coil has a positive by-pass factor (BPF > 0), then some amount of ventilation air directly enters the conditioned space, in which case it becomes a part of the building cooling load. The **sensible and latent heat transfer rates due to the by-passed ventilation air** can be calculated using equations (35.5) and (35.6) by replacing  $\dot{V}_o$  with  $\dot{V}_{vent} \cdot BPF$ , where  $\dot{V}_{vent}$  is the ventilation rate and BPF is the by-pass factor of the cooling coil.

In addition to this, **sensible and latent heat transfer to the building due to heat transfer and air leakage in the supply ducts**. A safety factor is usually provided to account for this depending upon the specific details of the supply air ducts.

If the supply duct consists of supply air fan with motor, then **power input to the fan** becomes a part of the external sensible load on the building. If the duct consists of the electric motor, which drives the fan, then the efficiency of the fan motor also must be taken into account while calculating the cooling load. Most of the times, the power input to the fan is not known *a priori* as the amount of supply air required is not known at this stage. To take this factor into account, initially it is assumed that the supply fan adds about 5% of the room sensible cooling load and cooling loads are then estimated. Then this value is corrected in the end when the actual fan selection is done.

### 35.4.2. Estimation of internal loads:

The internal loads consist of load due to occupants, due to lighting, due to equipment and appliances and due to products stored or processes being performed in the conditioned space.

**a) Load due to occupants:** The internal cooling load due to occupants consists of both sensible and latent heat components. The rate at which the sensible and latent heat transfer take place depends mainly on the population and activity level of the occupants. Since a portion of the heat transferred by the occupants is in the form of radiation, a Cooling Load Factor (CLF) should be used similar to that used for radiation heat transfer through fenestration. Thus the sensible heat transfer to the conditioned space due to the occupants is given by the equation:

$$Q_{s, occupants} = (\text{No. of people}) \cdot (\text{Sensible heat gain/person}) \cdot CLF \quad (35.10)$$

Table 35.3 shows typical values of total heat gain from the occupants and also the sensible heat gain fraction as a function of activity in an air conditioned space. However, it should be noted that the fraction of the total heat gain that is sensible depends on the conditions of the indoor environment. If the conditioned space temperature is higher, then the fraction of total heat gain that is sensible decreases and the latent heat gain increases, and vice versa.

Activity	Total heat gain, W	Sensible heat gain fraction
Sleeping	70	0.75
Seated, quiet	100	0.60
Standing	150	0.50
Walking @ 3.5 kmph	305	0.35
Office work	150	0.55
Teaching	175	0.50
Industrial work	300 to 600	0.35

**Table 35.3:** Total heat gain, sensible heat gain fraction from occupants

The value of Cooling Load Factor (CLF) for occupants depends on the hours after the entry of the occupants into the conditioned space, the total hours spent in the conditioned space and type of the building. Values of CLF have been obtained for different types of buildings and have been tabulated in ASHRAE handbooks.

Since the latent heat gain from the occupants is instantaneous the CLF for latent heat gain is 1.0, thus the latent heat gain due to occupants is given by:

$$Q_{l,occupants} = (\text{No. of people})(\text{Latent heat gain/person}) \quad (35.11)$$

**b) Load due to lighting:** Lighting adds sensible heat to the conditioned space. Since the heat transferred from the lighting system consists of both radiation and convection, a Cooling Load Factor is used to account for the time lag. Thus the cooling load due to lighting system is given by:

$$Q_{s,lighting} = (\text{Installed wattage})(\text{Usage Factor})(\text{Ballast factor})\text{CLF} \quad (35.12)$$

The usage factor accounts for any lamps that are installed but are not switched on at the time at which load calculations are performed. The ballast factor takes into account the load imposed by ballasts used in fluorescent lights. A typical ballast factor value of 1.25 is taken for fluorescent lights, while it is equal to 1.0 for incandescent lamps. The values of CLF as a function of the number of hours after the lights are turned on, type of lighting fixtures and the hours of operation of the lights are available in the form of tables in ASHRAE handbooks.

**c) Internal loads due to equipment and appliances:** The equipment and appliances used in the conditioned space may add both sensible as well as latent loads to the conditioned space. Again, the sensible load may be in the form of radiation and/or convection. Thus the internal sensible load due to equipment and appliances is given by:

$$Q_{s,appliance} = (\text{Installed wattage}) \cdot (\text{Usage Factor}) \cdot \text{CLF} \quad (35.13)$$

The installed wattage and usage factor depend on the type of the appliance or equipment. The CLF values are available in the form of tables in ASHARE handbooks.

The latent load due to appliances is given by:

$$Q_{l,appliance} = (\text{Installed wattage}) \cdot (\text{Latent heat fraction}) \quad (35.11)$$

Table 35.4 shows typical load of various types of appliances.

Appliance	Sensible load, W	Latent load, W	Total load, W
Coffee brewer, 0.5 gallons	265	65	330
Coffee warmer, 0.5 gallons	71	27	98
Toaster, 360 slices/h	1500	382	1882
Food warmer/m <sup>2</sup> plate area	1150	1150	2300

**Table 35.4:** Typical appliance load (C.P. Arora)

For other equipment such as computers, printers etc, the load is in the form of sensible heat transfer and is estimated based on the rated power consumption. The CLF value for these equipment may be taken as 1.0 as the radiative heat transfer from these equipment is generally negligible due to smaller operating temperatures. When the equipment are run by electric motors which are also kept inside the conditioned space, then the efficiency of the electric motor must be taken into account. Though the estimation of cooling load due to appliance and equipment appears to be simple as given by the equations, a large amount of uncertainty is introduced on account of the usage factor and the difference between rated (nameplate) power consumption at full loads and actual power consumption at part loads. Estimation using nameplate power input may lead to overestimation of the loads, if the equipment operates at part load conditions most of the time.

If the conditioned space is used for storing products (e.g. cold storage) or for carrying out certain processes, then the sensible and latent heat released by these specific products and or the processes must be added to the internal cooling loads. The sensible and latent heat release rate of a wide variety of live and dead products commonly stored in cold storages are available in air conditioning and refrigeration handbooks. Using these tables, one can estimate the required cooling capacity of cold storages.

Thus using the above equations one can estimate the sensible ( $Q_{s,r}$ ), latent ( $Q_{l,r}$ ) and total cooling load ( $Q_{t,r}$ ) on the buildings. Since the load due to sunlit

surfaces varies as a function of solar time, it is preferable to calculate the cooling loads at different solar times and choose the maximum load for estimating the system capacity. From the sensible and total cooling loads one can calculate the Room Sensible Heat Factor (RSHF) for the building. As discussed in an earlier chapter, from the RSHF value and the required indoor conditions one can draw the RSHF line on the psychrometric chart and fix the condition of the supply air.

### 35.5. Estimation of the cooling capacity of the system:

In order to find the required cooling capacity of the system, one has to take into account the **sensible and latent loads due to ventilation, leakage losses** in the return air ducts and heat added due to **return air fan** (if any).

#### 37.5.1. Load on the system due to ventilated air:

Figure 35.2 shows a schematic of an air conditioning system with the cooling coil, supply and return ducts, ventilation and fans. The cooling coil has a by-pass factor  $X$ . Then the cooling load on the coil due to sensible heat transfer of the ventilated air is given by:

$$Q_{s,vent} = \dot{m}_{vent} (1 - X) \cdot c_{p,m} (T_o - T_i) = \dot{V}_{vent} \rho_o (1 - X) \cdot c_{p,m} (T_o - T_i) \quad (35.12)$$

where  $\dot{m}_{vent}$  and  $\dot{V}_{vent}$  are the mass and volumetric flow rates of the ventilated air and  $X$  is the by-pass factor of the coil.

The latent heat load on the coil due to ventilation is given by:

$$Q_{l,vent} = \dot{m}_{vent} (1 - X) \cdot h_{fg} (W_o - W_i) = \dot{V}_{vent} \rho_o (1 - X) \cdot h_{fg} (W_o - W_i) \quad (35.13)$$

where  $W_o$  and  $W_i$  are the humidity ratios of the ambient and conditioned air, respectively and  $h_{fg}$  is the latent heat of vapourization of water.

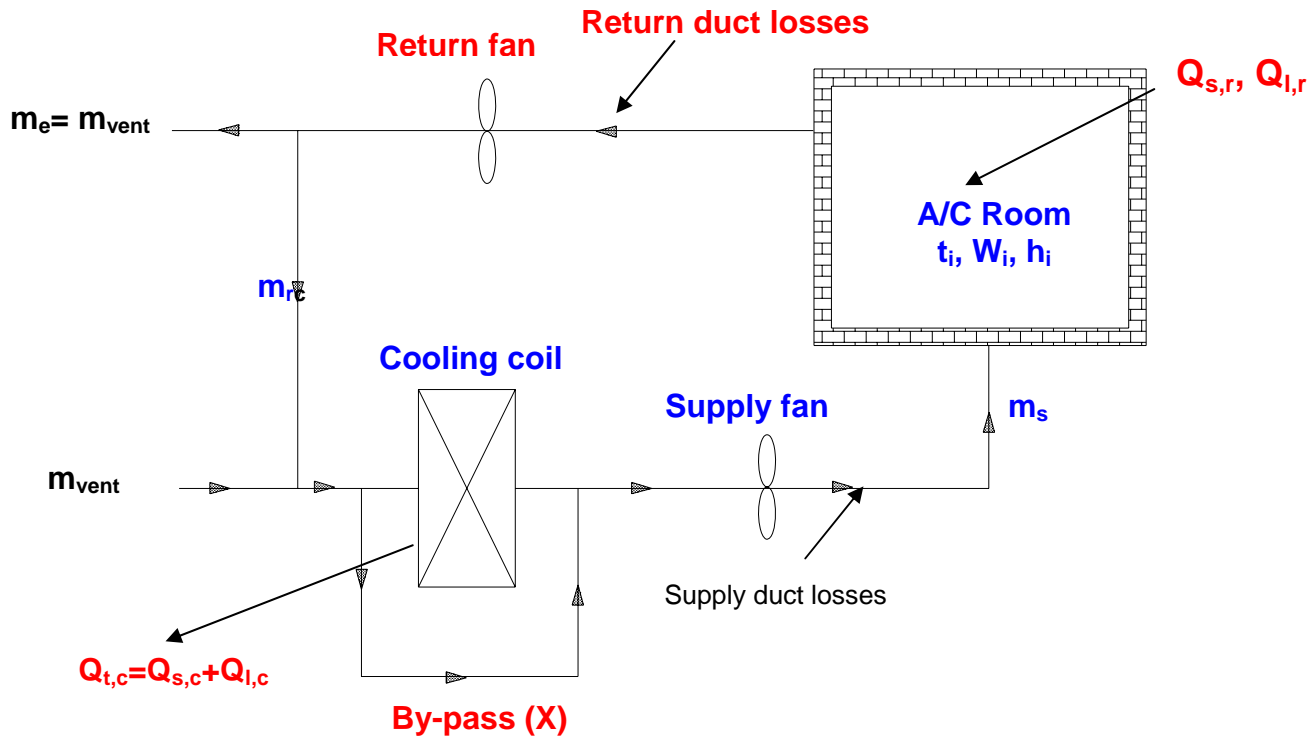
#### 35.4.2. Load on the coil due to leakage in return air duct and due to return air fan:

If there is leakage of air and heat from or to the return air duct, additional capacity has to be provided by the cooling coil to take care of this. The sensible heat transfer to the return duct due to heat transfer from the surroundings to the return duct depends on the surface area of the duct that is exposed to outside air ( $A_{exposed}$ ), amount of insulation ( $U_{ins}$ ) and temperature difference between outdoor air and return air, i.e.,

$$Q_{s,duct} = U_{ins} \cdot A_{exposed} (T_o - T_i) \quad (35.14)$$

The amount of sensible and latent heat transfer rates due to air leakage from or to the system depends on the effectiveness of the sealing provided and the

condition of the outdoor air and return air. Since the load due to return air duct including the return air fan ( $Q_{\text{return duct}}$ ) are not known a priori an initial value (e.g. as a fraction of total building cooling load) is assumed and calculations are performed. This value is modified at the end by taking into account the actual leakage losses



**Fig.35.2:** A typical summer air conditioning system with a cooling coil of non-zero by-pass factor

and return fan power consumption.

Now the total sensible load on the coil ( $Q_{s,c}$ ) is obtained by summing up the total sensible load on the building ( $Q_{s,r}$ ), sensible load due to ventilation ( $Q_{s,vent}$ ) and sensible load due to return air duct and fan ( $Q_{s,return duct}$ ), that is:

$$Q_{s,c} = Q_{s,r} + Q_{s,vent} + Q_{s,return duct} \quad (35.15)$$

Similarly the total latent load on the coil ( $Q_{l,c}$ ) is obtained by summing up the total latent load on the building ( $Q_{l,r}$ ), latent load due to ventilation ( $Q_{l,vent}$ ) and latent load due to return air duct and fan ( $Q_{l,return duct}$ ), that is:

$$Q_{l,c} = Q_{l,r} + Q_{l,vent} + Q_{l,return duct} \quad (35.15)$$

Finally the required cooling capacity of the system which is equal to the total load on the coil is obtained from the equation:

$$\text{Required cooling capacity, } Q_{t,c} = Q_{s,c} + Q_{l,c} \quad (35.16)$$

One can also calculate the sensible heat factor for the coil (CSHF) and draw the process line on the psychrometric chart and find the required coil Apparatus Dew

Point Temperature (coil ADP) from the above data as discussed in an earlier chapter.

As mentioned, the method discussed above is based on CLTD/CLF as suggested by ASHRAE. It can be seen that with the aid of suitable input data and building specifications one can manually estimate the cooling load on the building and the required cooling capacity of the system. A suitable **safety factor** is normally used in the end to account for uncertainties in occupants, equipment, external infiltration, external conditions etc. This relatively simple method offers reasonably accurate results for most of the buildings. However, it should be noted that the data available in ASHRAE handbooks (e.g. CLTD tables, SHGF tables) have been obtained for a specific set of conditions. Hence, any variation from these conditions introduces some amount of error. Though this is generally taken care by the safety factor (i.e., by selecting a slightly oversized cooling system), for more accurate results one has to resort actual building simulation taking into account on all relevant factors that affect the cooling load. However, this could be highly complex mathematically and hence time consuming and expensive. The additional cost and effort may be justified for large buildings with large amount of cooling loads, but may not be justified for small buildings. Thus depending upon the specific case one has to select suitable load calculation method.

## 35.6 Heating load calculations:

As mentioned before, conventionally **steady state conditions** are assumed for estimating the building heating loads and the internal heat sources are neglected. Then the procedure for heating load calculations becomes fairly simple. One has to estimate only the sensible and latent heat losses from the building walls, roof, ground, windows, doors, due to infiltration and ventilation. Equations similar to those used for cooling load calculations are used with the difference that the **CLTD values are simply replaced by the design temperature difference between the conditioned space and outdoors**. Since a steady state is assumed, the required heating capacity of the system is equal to the total heat loss from the building. As already mentioned, by this method, the calculated heating system capacity will always be more than the actual required cooling capacity. However, the difference may not be very high as long as the internal heat generation is not very large (i.e., when the building is not internally loaded). However, when the internal heat generation rate is large and/or when the building has large thermal capacity with a possibility of storing solar energy during day time, then using more rigorous unsteady approach by taking the internal heat sources into account yields significantly small heating small capacities and hence low initial costs. Hence, once again depending on the specific case one has to select a suitable and economically justifiable method for estimating heating loads.

## Questions and answers:

1. Which of the following statements are TRUE?

- a) Steady state methods are justified in case of heating load calculations as the outside temperatures during winter are normally very low
- b) Steady state methods are justified in case of heating load calculations as the peak load normally occurs before sunrise
- c) Steady state methods are justified in case of heating load calculations as the outside temperature variation is normally low during winter months
- d) Neglecting internal heat sources while calculating heating loads underestimates the required capacity

**Ans.: b) and c)**

2. Which of the following statements are TRUE?

- a) An all year air conditioning system has to be switched from winter mode to summer mode as the outdoor temperature exceeds the outdoor temperature at balance point
- b) An all year air conditioning system has to be switched from summer mode to winter mode as the outdoor temperature exceeds the outdoor temperature at balance point
- c) The outdoor temperature at balance point increases as the amount of insulation increases
- d) The outdoor temperature at balance point decreases as the amount of insulation increases

**Ans.: a) and d)**

3. Which of the following statements are TRUE?

- a) Methods based on rules-of-thumb are not always useful as they are not based on practical systems
- b) Methods based on rules-of-thumb are not always useful as they do not distinguish between a good building design and a bad building design
- c) Methods based on Transfer Function Method are not always useful as they do not yield accurate results
- d) Methods based on Transfer Function Method are not always useful as they are complex and time consuming

**Ans.: b) and d)**

4. Which of the following statements are TRUE?

- a) An internally loaded building requires a system with variable cooling capacity
- b) An externally loaded building requires a system with variable cooling capacity
- c) An auditorium is a good example of an internally loaded building
- d) A residence is a good example of an internally loaded building



**Ans.: b) and d)**

5. Which of the following statements are TRUE?

- a) External loads consist of only sensible components, where as internal loads consist of both sensible and latent components
- b) Both external and internal loads consist of sensible as well as latent components
- c) Fabric heat gain consists of both sensible and latent components
- d) Heat transfer due to occupancy consists of both sensible and latent components

**Ans.: b) and d)**

6. Which of the following statements are TRUE?

- a) Cooling Load Factor is used for radiative component only
- b) Cooling Load Factor is used for both radiative as well as convective components
- c) The value of cooling load factor always lies between 0 and 1
- d) The cooling load factor increases as the thermal capacity of the walls increase

**Ans.: a) and c)**

7. Which of the following statements are TRUE?

- a) Infiltration load is a part of the building load
- b) Infiltration load is not a part of the building load
- c) Infiltration rate increases as the pressure difference across the building decreases
- d) Infiltration rate is uncontrollable

**Ans.: a)**

8. Which of the following statements are TRUE?

- a) Ventilation is to be considered while calculating load on the coil, not on buildings
- b) Ventilation is to be considered while calculating load on the coil, not on buildings only when the by-pass factor of the cooling coil is zero
- c) Ventilation is to be considered while calculating load on the coil, not on buildings only when the by-pass factor of the cooling coil is non-zero
- d) Losses in supply duct are a part of the building load, while losses in return duct are a part of the coil load

**Ans.: b) and d)**

9. A building has a U-value of  $0.5 \text{ W/m}^2\text{.K}$  and a total exposed surface area of  $384 \text{ m}^2$ . The building is subjected to an external load (only sensible) of  $2 \text{ kW}$  and an internal load of  $1.2 \text{ kW}$  (sensible). If the required internal temperature is  $25^\circ\text{C}$ , state

whether a cooling system is required or a heating system is required when the external temperature is 3°C. How the results will change, if the U-value of the building is reduced to 0.36 W/m.K?

**Ans.:** From energy balance,

$$T_{\text{out,bal}} = T_{\text{in}} - \frac{(Q_{\text{solar}} + Q_{\text{int}})_{\text{sensible}}}{UA} = 25 - \frac{(2 + 1.2) \times 1000}{0.5 \times 384} = 8.33^{\circ}\text{C}$$

Since the outdoor temperature at balance point is greater than the external temperature ( $T_{\text{ext}} < T_{\text{out,bal}}$ );

**the building requires heating (Ans.)**

When the U-value of the building is reduced to 0.36 W/m.K, the new balanced outdoor temperature is given by:

$$T_{\text{out,bal}} = T_{\text{in}} - \frac{(Q_{\text{solar}} + Q_{\text{int}})_{\text{sensible}}}{UA} = 25 - \frac{(2 + 1.2) \times 1000}{0.36 \times 384} = 1.85^{\circ}\text{C}$$

Since now the outdoor temperature at balance point is smaller than the external temperature ( $T_{\text{ext}} > T_{\text{out,bal}}$ );

**the building now requires cooling (Ans.)**

The above example shows that adding more insulation to a building extends the cooling season and reduces the heating season.

**10.** An air conditioned room that stands on a well ventilated basement measures 3 m wide, 3 m high and 6 m deep. One of the two 3 m walls faces west and contains a double glazed glass window of size 1.5 m by 1.5 m, mounted flush with the wall with no external shading. There are no heat gains through the walls other than the one facing west. Calculate the sensible, latent and total heat gains on the room, room sensible heat factor from the following information. What is the required cooling capacity?

Inside conditions	:	25°C dry bulb, 50 percent RH
Outside conditions	:	43°C dry bulb, 24°C wet bulb
U-value for wall	:	1.78 W/m <sup>2</sup> .K
U-value for roof	:	1.316 W/m <sup>2</sup> .K
U-value for floor	:	1.2 W/m <sup>2</sup> .K
Effective Temp. Difference (ETD) for wall:		25°C
Effective Temp. Difference (ETD) for roof:		30°C
U-value for glass	;	3.12 W/m <sup>2</sup> .K
Solar Heat Gain (SHG) of glass	;	300 W/m <sup>2</sup>
Internal Shading Coefficient (SC) of glass:		0.86
Occupancy	:	4 (90 W sensible heat/person) (40 W latent heat/person)
Lighting load	:	33 W/m <sup>2</sup> of floor area

Appliance load	:	600 W (Sensible) + 300 W(latent)
Infiltration	:	0.5 Air Changes per Hour
Barometric pressure	:	101 kPa

**Ans.:** From psychrometric chart,

For the inside conditions of 25°C dry bulb, 50 percent RH:

$$W_i = 9,9167 \times 10^{-3} \text{ kgw/kgda}$$

For the outside conditions of 43°C dry bulb, 24°C wet bulb:

$$W_o = 0.0107 \text{ kgw/kgda, density of dry air} = 1.095 \text{ kg/m}^3$$

### External loads:

a) Heat transfer rate through the walls: Since only west wall measuring 3m x 3m with a glass windows of 1.5m x 1.5m is exposed; the heat transfer rate through this wall is given by:

$$Q_{\text{wall}} = U_{\text{wall}} A_{\text{wall}} \text{ETD}_{\text{wall}} = 1.78 \times (9-2.25) \times 25 = 300.38 \text{ W (Sensible)}$$

b) Heat transfer rate through roof:

$$Q_{\text{roof}} = U_{\text{roof}} A_{\text{roof}} \text{ETD}_{\text{roof}} = 1.316 \times 18 \times 30 = 710.6 \text{ W (Sensible)}$$

c) Heat transfer rate through floor: Since the room stands on a well-ventilated basement, we can assume the conditions in the basement to be same as that of the outside (i.e., 43°C dry bulb and 24°C wet bulb), since the floor is not exposed to solar radiation, the driving temperature difference for the roof is the temperature difference between the outdoor and indoor, hence:

$$Q_{\text{floor}} = U_{\text{floor}} A_{\text{floor}} \text{ETD}_{\text{floor}} = 1.2 \times 18 \times 18 = 388.8 \text{ W (Sensible)}$$

d) Heat transfer rate through glass: This consists of the radiative as well as conductive components. Since no information is available on the value of CLF, it is taken as 1.0. Hence the total heat transfer rate through the glass window is given by:

$$Q_{\text{glass}} = A_{\text{glass}} [U_{\text{glass}}(T_o - T_i) + \text{SHGF}_{\text{max}} \text{SC}] = 2.25[3.12 \times 18 + 300 \times 0.86] = 706.9 \text{ W}$$

**(Sensible)**

e) Heat transfer due to infiltration: The infiltration rate is 0.5 ACH, converting this into mass flow rate, the infiltration rate in kg/s is given by:

$$m_{\text{inf}} = \text{density of air} \times (\text{ACH} \times \text{volume of the room})/3600 = 1.095 \times (0.5 \times 3 \times 3 \times 6)/3600$$

$$m_{\text{inf}} = 8.2125 \times 10^{-3} \text{ kg/s}$$

Sensible heat transfer rate due to infiltration,  $Q_{s,inf}$ :

$$Q_{s,inf} = m_{inf}c_{pm}(T_o - T_i) = 8.2125 \times 10^{-3} \times 1021.6 \times (43 - 25) = 151 \text{ W (Sensible)}$$

Latent heat transfer rate due to infiltration,  $Q_{l,inf}$ :

$$Q_{l,inf} = m_{inf}h_{fg}(W_o - W_i) = 8.8125 \times 10^{-3} \times 2501 \times 10^3(0.0107 - 0.0099) = 16.4 \text{ W (sensible)}$$

### Internal loads:

a) Load due to occupants: The sensible and latent load due to occupants are:

$$Q_{s,occ} = \text{no. of occupants} \times \text{SHG} = 4 \times 90 = 360 \text{ W}$$

$$Q_{l,occ} = \text{no. of occupants} \times \text{LHG} = 4 \times 40 = 160 \text{ W}$$

b) Load due to lighting: Assuming a CLF value of 1.0, the load due to lighting is:

$$Q_{lights} = 33 \times \text{floor area} = 33 \times 18 = 594 \text{ W (Sensible)}$$

c) Load due to appliance:

$$Q_{s,app} = 600 \text{ W (Sensible)}$$

$$Q_{l,app} = 300 \text{ W (Latent)}$$

Total sensible and latent loads are obtained by summing-up all the sensible and latent load components (both external as well as internal) as:

$$Q_{s,total} = 300.38 + 710.6 + 388.8 + 706.9 + 151 + 360 + 594 + 600 = 3811.68 \text{ W (Ans.)}$$

$$Q_{l,total} = 16.4 + 160 + 300 = 476.4 \text{ W (Ans.)}$$

Total load on the building is:

$$Q_{total} = Q_{s,total} + Q_{l,total} = 3811.68 + 476.4 = 4288.08 \text{ W (Ans.)}$$

Room Sensible Heat Factor (RSHF) is given by:

$$\text{RSHF} = Q_{s,total} / Q_{total} = 3811.68 / 4288.08 = 0.889 \text{ (Ans.)}$$

To calculate the required cooling capacity, one has to know the losses in return air ducts. Ventilation may be neglected as the infiltration can take care of the small ventilation requirement. Hence using a safety factor of 1.25, the required cooling capacity is:

$$\text{Required cooling capacity} = 4288.08 \times 1.25 = 5360.1 \text{ W} \approx 1.5 \text{ TR (Ans.)}$$

# Lesson

## 36

# Selection Of Air Conditioning Systems

## The specific objectives of this chapter are to:

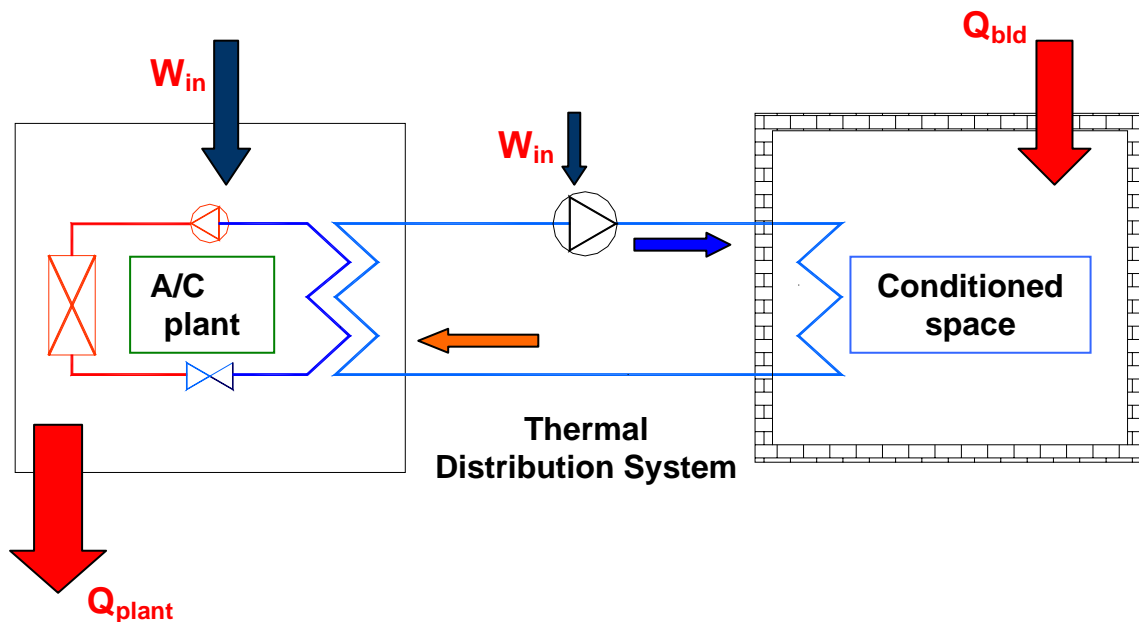
1. Introduction to thermal distribution systems and their functions (*Section 36.1*)
2. Selection criteria for air conditioning systems (*Section 36.1*)
3. Classification of air conditioning systems (*Section 36.3*)
4. Working principle, advantages, disadvantages and applications of all air systems, namely:
  - a) Single duct, constant volume, single zone systems (*Section 36.4.1*)
  - b) Single duct, constant volume, multiple zone systems (*Section 36.4.2*)
  - c) Single duct, variable air volume (VAV) systems (*Section 36.4.3*)
  - d) Dual duct, constant volume and variable volume systems (*Section 36.4.4*)
  - e) Outdoor air control in all air systems (*Section 36.4.5*)
  - f) Advantages of all air systems (*Section 36.4.6*)
  - g) Disadvantages of all air systems (*Section 36.4.7*)
  - h) Applications of all air systems (*Section 36.4.8*)
5. Working principle, advantages, disadvantages and applications of all water systems (*Section 36.5*)
6. Working principle, advantages, disadvantages and applications of air- water systems (*Section 36.6*)
7. Working principle, advantages, disadvantages and applications of unitary refrigerant based systems (*Section 36.7*)

At the end of this chapter, the student should be able to:

1. Explain the function of a thermal distribution system
2. Discuss the criteria used for selection of air conditioning systems
3. Classify air conditioning systems
4. Discuss the working principle with suitable diagrams, advantages, disadvantages and applications of different types of all air systems, all water systems, air-water systems and unitary refrigerant based systems.

## 36.1. Introduction:

In order to maintain required conditions inside the conditioned space, energy has to be either supplied or extracted from the conditioned space. The energy in the form of sensible as well as latent heat has to be supplied to the space in winter and extracted from the conditioned space in case of summer. An air conditioning system consists of an air conditioning plant and a thermal distribution system as shown in Fig. 36.1. As shown in the figure, the air conditioning (A/C) plant acts either as a heat source (in case of winter systems) or as a heat sink (in case of summer systems). Air, water or refrigerant are used as media for transferring energy from the air conditioning plant to the conditioned space. A thermal distribution system is required to circulate the media between the conditioned space and the A/C plant. Another important function of the thermal distribution system is to introduce the required amount of fresh air into the conditioned space so that the required Indoor Air Quality (IAQ) can be maintained.



*Fig.36.1: Schematic of a summer air conditioning system with the thermal distribution system*

## 36.2. Selection criteria for air conditioning systems:

Selection of a suitable air conditioning system depends on:

1. Capacity, performance and spatial requirements
2. Initial and running costs
3. Required system reliability and flexibility
4. Maintainability
5. Architectural constraints

The relative importance of the above factors varies from building owner to owner and may vary from project to project. The typical space requirement for large air conditioning systems may vary from about 4 percent to about 9 percent of the gross building area, depending upon the type of the system. Normally based on the selection criteria, the choice is narrowed down to 2 to 3 systems, out of which one will be selected finally.

### 36.3. Classification of air conditioning systems:

Based on the fluid media used in the thermal distribution system, air conditioning systems can be classified as:

1. All air systems
2. All water systems
3. Air- water systems
4. Unitary refrigerant based systems

### 36.4. All air systems:

As the name implies, in an all air system air is used as the media that transports energy from the conditioned space to the A/C plant. In these systems air is processed in the A/C plant and this processed air is then conveyed to the conditioned space through insulated ducts using blowers and fans. This air extracts (or supplies in case of winter) the required amount of sensible and latent heat from the conditioned space. The return air from the conditioned space is conveyed back to the plant, where it again undergoes the required processing thus completing the cycle. No additional processing of air is required in the conditioned space. All air systems can be further classified into:

1. Single duct systems, or
2. Dual duct systems

The single duct systems can provide either cooling or heating using the same duct, but not both heating and cooling simultaneously. These systems can be further classified into:

1. Constant volume, single zone systems
2. Constant volume, multiple zone systems
3. Variable volume systems

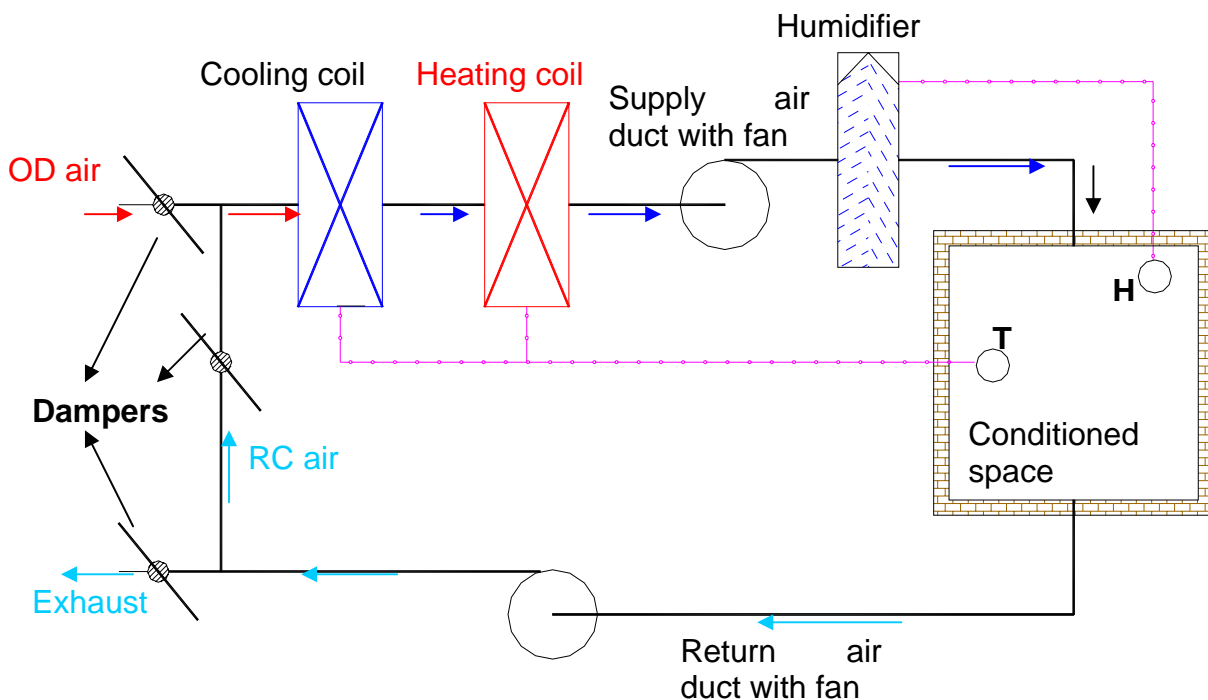


The dual duct systems can provide both cooling and heating simultaneously. These systems can be further classified into:

1. Dual duct, constant volume systems
2. Dual duct variable volume systems

### 36.4.1. Single duct, constant volume, single zone systems:

Figure 36.2 shows the classic, single duct, single zone, constant volume systems. As shown in the figure, outdoor air (OD air) for ventilation and recirculated air (RC air) are mixed in the required proportions using the dampers and the mixed air is made to flow through a cooling and dehumidifying coil, a heating coil and a humidifier using an insulated ducting and a supply fan. As the air flows through these coils the temperature and moisture content of the air are brought to the required values. Then this air is supplied to the conditioned space, where it meets the building cooling or heating requirements. The return air leaves the conditioned space, a part of it is recirculated and the remaining part is vented to the atmosphere. A thermostat senses the temperature of air in the conditioned space and controls the amount of cooling or heating provided in the coils so that the supply air temperature can be controlled as per requirement. A humidistat measures the humidity ratio in the conditioned space and controls the amount of water vapour added in the humidifier and hence the supply air humidity ratio as per requirement.



**Fig.36.2.** A constant volume, single zone system

This system is called as a single duct system as there is only **one supply duct**, through which either hot air or cold air flows, but not both simultaneously. It is called as a constant volume system as the **volumetric flow rate of supply air** is always **maintained constant**. It is a single zone system as the control is based on

temperature and humidity ratio measured at a single point. Here a zone refers to a space controlled by one thermostat. However, the single zone may consist of a single room or one floor or whole of a building consisting of several rooms. The cooling/ heating capacity in the single zone, constant volume systems is regulated by regulating the supply air temperature and humidity ratio, while keeping the supply airflow rate constant. A separate sub-system controls the amount of OD air supplied by controlling the damper position.

Since a single zone system is controlled by a single thermostat and humidistat, it is **important to locate these sensors** in a proper location, so that they are indicative of zone conditions. The **supply air conditions** are controlled by either coil control or face-and-bypass control.

**In coil control**, supply air temperature is controlled by varying the **flow rate of cold and hot water** in the cooling and heating coils, respectively. As the cooling season gradually changes to heating season, the cooling coil valve is gradually closed and heating coil valve is opened. Though coil control is simpler, using this type of control it is **not possible to control the zone humidity** precisely as the dehumidification rate in the cooling coil decreases with cold water flow rate. Thus at low cold water flow rates, the humidity ratio of the conditioned space is likely to be higher than required.

**In face-and-bypass control**, the cold and hot water flow rates are maintained constant, but the amount of air flowing over the coils are decreased or increased by opening or closing the by-pass dampers, respectively. By this method it is possible to **control the zone humidity more precisely**, however, this type of control occupies more space physically and is also expensive compared to coil control.

#### **Applications of single duct, single zone, constant volume systems:**

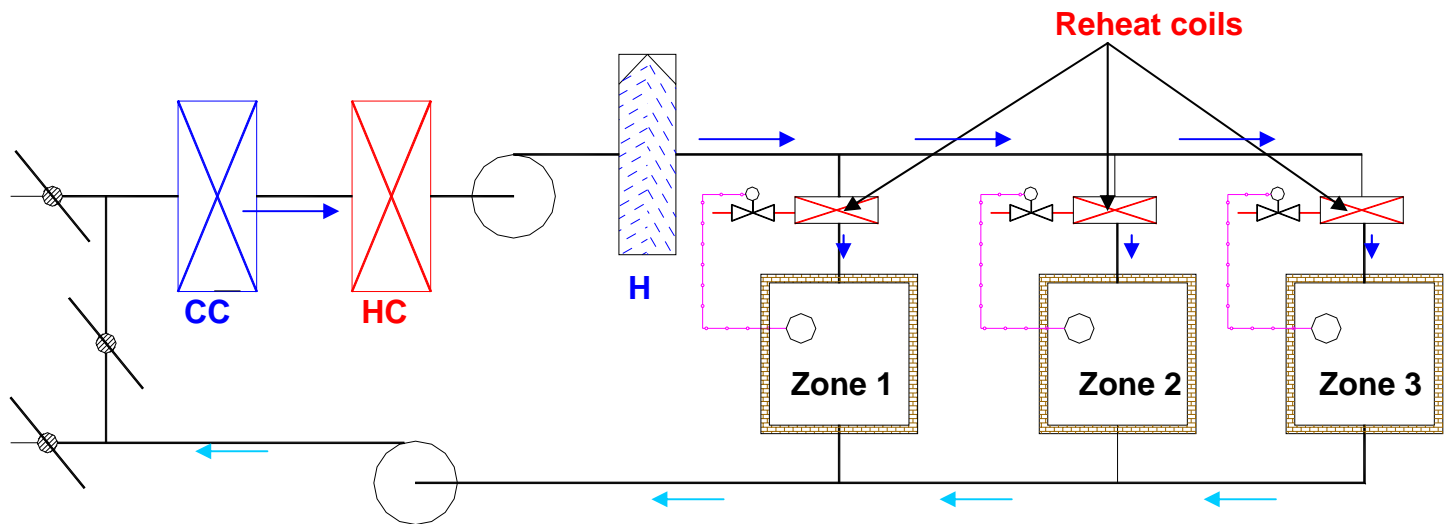
1. Spaces with uniform loads, such as large open areas with small external loads e.g. theatres, auditoria, departmental stores.
2. Spaces requiring precision control such as laboratories

The Multiple, single zone systems can be used in large buildings such as factories, office buildings etc.

#### **36.4.2. Single duct, constant volume, multiple zone systems:**

For very large buildings with several zones of different cooling/heating requirements, it is not economically feasible to provide separate single zone systems for each zone. For such cases, multiple zone systems are suitable. Figure 36.3 shows a single duct, multiple zone system with terminal reheat coils. In these systems all the air is cooled and dehumidified (**for summer**) or heated and humidified (**for winter**) to a given minimum or maximum temperature and humidity ratio. A constant volume of this air is supplied to the reheat coil of each zone. In the reheat coil the supply air temperature is increased further to a required level depending upon the load on that particular zone. This is achieved by a zone thermostat, which

controls the amount of reheat, and hence the supply air temperature. The reheat coil may run on either electricity or hot water.



**Fig.36.3.** Single duct, constant volume system with multiple zones and reheat coils

**Advantages of single duct, multiple zone, constant volume systems with reheat coils:**

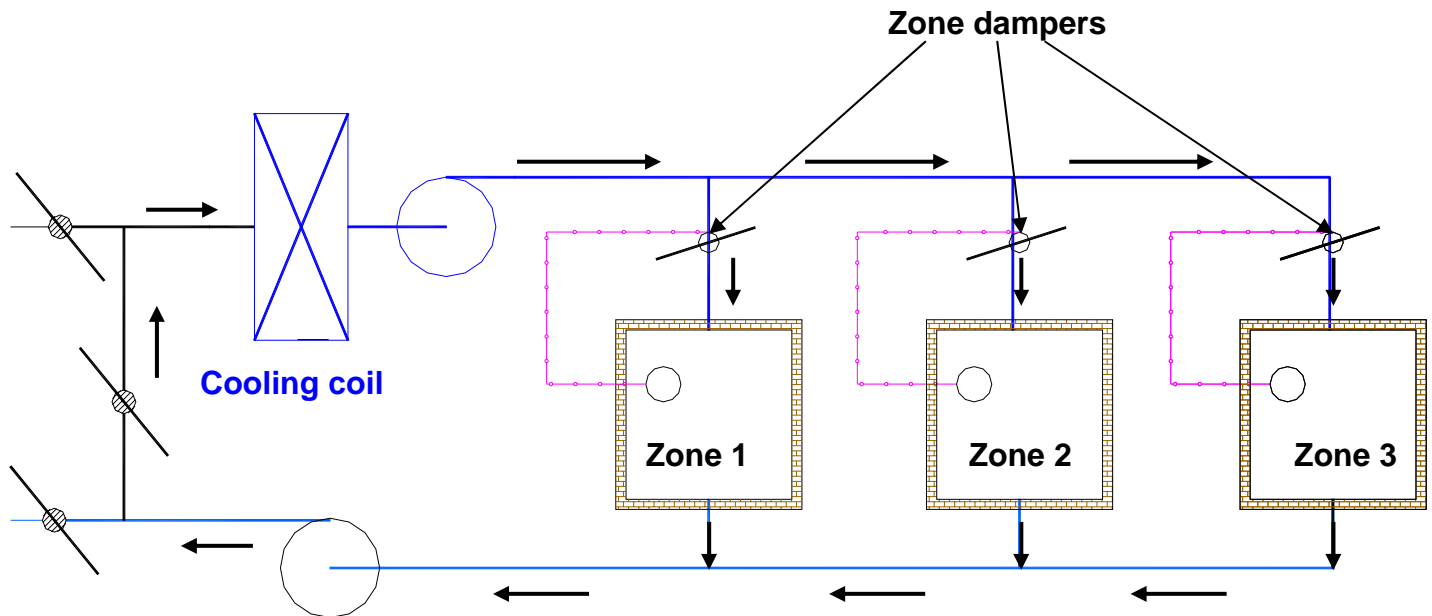
- a) Relatively small space requirement
- b) Excellent temperature and humidity control over a wide range of zone loads
- c) Proper ventilation and air quality in each zone is maintained as the supply air amount is kept constant under all conditions

**Disadvantages of single duct, multiple zone, constant volume systems with reheat coils:**

- a) High energy consumption for cooling, as the air is first cooled to a very low temperature and is then heated in the reheat coils. Thus energy is required first for cooling and then for reheating. The energy consumption can partly be reduced by increasing the supply air temperature, such that at least one reheat coil can be switched-off all the time. The energy consumption can also be reduced by using waste heat (such as heat rejected in the condensers) in the reheat coil.
- b) Simultaneous cooling and heating is not possible.

### 36.4.3. Single duct, variable air volume (VAV) systems:

Figure 36.4 shows a single duct, multiple zone, variable air volume system for summer air conditioning applications. As shown, in these systems air is cooled and dehumidified to a required level in the cooling and dehumidifying coil (CC). A



**Fig.36.4:** Single duct, multiple zone, variable air volume system

variable volume of this air is supplied to each zone. The amount of air supplied to each zone is controlled by a zone damper, which in turn is controlled by that zone thermostat as shown in the figure. Thus the temperature of supply air to each zone remains constant, whereas its flow rate varies depending upon the load on that particular zone.

Compared to constant volume systems, the variable air volume systems offer advantages such as:

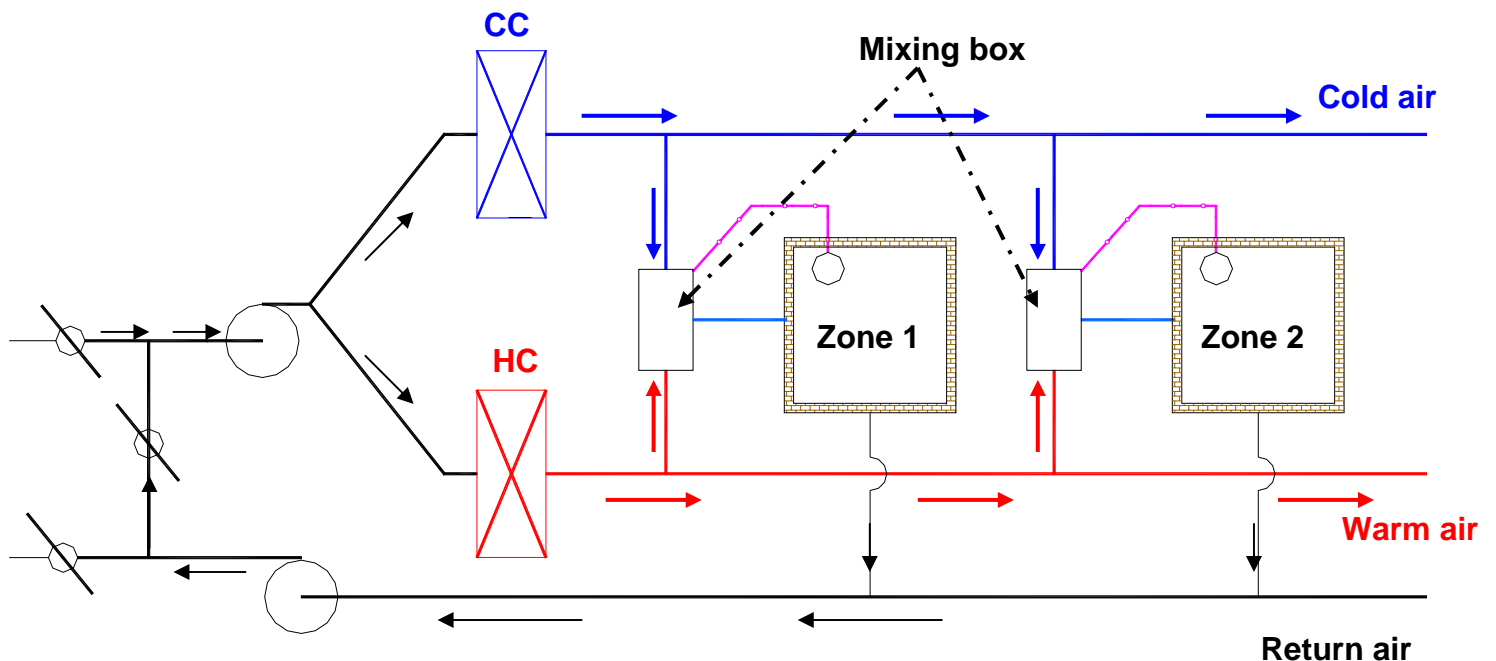
- Lower energy consumption in the cooling system as air is not cooled to very low temperatures and then reheated as in constant volume systems.
- Lower energy consumption also results due to lower fan power input due to lower flow rate, when the load is low. These systems lead to significantly lower power consumption, especially in perimeter zones where variations in solar load and outside temperature allows for reduced air flow rates.

However, since the flow rate is controlled, there could be problems with ventilation, IAQ and room air distribution when the zone loads are very low. In addition it is difficult to control humidity precisely using VAV systems. Balancing of dampers could be difficult if the airflow rate varies widely. However, by **combining VAV systems with terminal reheat it is possible to maintain the air flow rate at a minimum required level to ensure proper ventilation and room air distribution.** Many

other variations of VAV systems are available to cater to a wide variety of applications.

#### 36.4.4. Dual duct, constant volume systems:

Figure 36.5 shows the schematic of a dual duct, constant volume system. As shown in the figure, in a dual duct system the supply air fan splits the flow into two streams. One stream flows through the cooling coil and gets cooled and dehumidified to about  $13^{\circ}\text{C}$ , while the other stream flows through the heating coil and is heated to about  $35\text{--}45^{\circ}\text{C}$ . The cold and hot streams flow through separate ducts. Before each conditioned space or zone, the cold and hot air streams are mixed in required proportions using a mixing box arrangement, which is controlled by the zone thermostat. The total volume of air supplied to each zone remains constant, however, the supply air temperature varies depending upon load.



**Fig.36.5:** Dual duct, constant volume system

#### Advantages of dual duct systems:

1. Since total airflow rate to each zone is constant, it is possible to maintain proper IAQ and room air distribution.
2. Cooling in some zones and heating in other zones can be achieved simultaneously
3. System is very responsive to variations in the zone load, thus it is possible to maintain required conditions precisely.

### Disadvantages of dual duct systems:

1. Occupies more space as both cold air and hot air ducts have to be sized to handle all the air flow rate, if required.
2. Not very energy efficient due to the need for simultaneous cooling and heating of the air streams. However, the energy efficiency can be improved by completely shutting down the cooling coil when the outside temperature is low and mixing supply air from fan with hot air in the mixing box. Similarly, when the outside weather is hot, the heating coil can be completely shut down, and the cold air from the cooling coil can be mixed with supply air from the fan in the mixing box.

### 36.4.5. Dual duct, variable air volume systems:

These systems are similar to dual duct, constant volume systems with the only difference that instead of maintaining constant flow rates to each zone, the mixing boxes reduce the air flow rate as the load on the zone drops.

### 36.4.6. Outdoor air control in all air systems:

As mentioned in a previous lecture, outdoor air is required for ventilation purposes. In all air systems, a sub-system controls the amount of outdoor air by controlling the position of exhaust, re-circulated and outdoor air dampers. From mass balance, since the outdoor airflow rate should normally be equal to the exhaust airflow rate (unless building pressurization or de-pressurization is required), both the exhaust and outdoor air dampers open or close in unison. Again from mass balance, when the outdoor air damper opens the re-circulated air damper closes, and vice versa. The control system maintains a minimum amount of outdoor air (about 10 to 20% of supply air flow rate as required for ventilation) when the outdoor is too cold ( $\leq -30^{\circ}\text{C}$ ) or too warm ( $\geq 24^{\circ}\text{C}$ ). For energy conservation, the amount of outdoor air can be increased gradually as the outdoor air temperature increases from  $-30^{\circ}\text{C}$  to about  $13^{\circ}\text{C}$ . A 100 percent outdoor air can be used when the outdoor air temperature is between  $13^{\circ}\text{C}$  to about  $24^{\circ}\text{C}$ . By this method it is possible to reduce the annual energy consumption of the air conditioning system significantly, while maintaining the required conditions in the conditioned space.

### 36.4.7. Advantages of all air systems:

1. All air systems offer the greatest potential for energy conservation by utilizing the outdoor air effectively.
2. By using high-quality controls it is possible to maintain the temperature and relative humidity of the conditioned space within  $\pm 0.15^{\circ}\text{C}$  (DBT) and  $\pm 0.5\%$ , respectively.
3. Using dual duct systems, it is possible to provide simultaneous cooling and heating. Changeover from summer to winter and vice versa is relatively simple in all air systems.

4. It is possible to provide good room air distribution and ventilation under all conditions of load.
5. Building pressurization can be achieved easily.
6. The complete air conditioning plant including the supply and return air fans can be located away from the conditioned space. Due to this it is possible to use a wide variety of air filters and avoid noise in the conditioned space.

#### **36.4.8. Disadvantages of all air systems:**

1. They occupy more space and thus reduce the available floor space in the buildings. It could be difficult to provide air conditioning in high-rise buildings with the plant on the ground floor or basement due to space constraints.
2. Retrofitting may not always be possible due to the space requirement.
3. Balancing of air in large and particularly with variable air volume systems could be difficult.

#### **36.4.9. Applications of all air systems:**

All air systems can be used in both **comfort as well as industrial air conditioning** applications. They are especially suited to buildings that require individual control of multiple zones, such as **office buildings, classrooms, laboratories, hospitals, hotels, ships** etc. They are also used extensively in applications that require very close control of the conditions in the conditioned space such as **clean rooms, computer rooms, operation theatres, research facilities** etc.

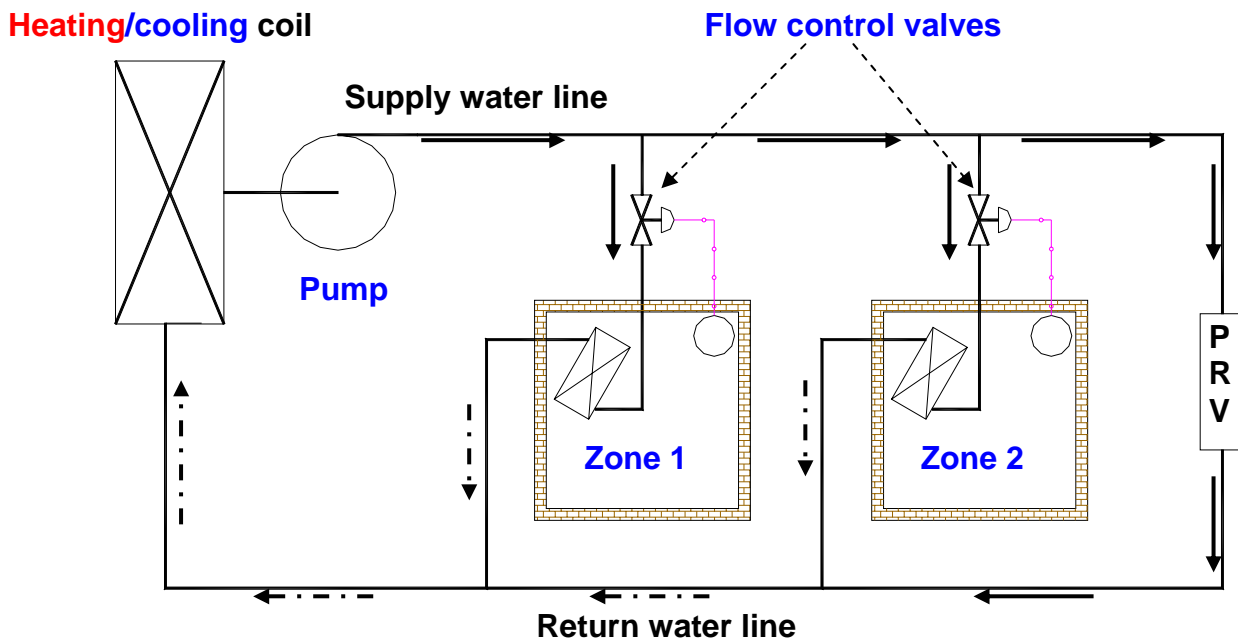
### **36.5. All water systems:**

In all water systems the fluid used in the thermal distribution system is water, i.e., water transports energy between the conditioned space and the air conditioning plant. When cooling is required in the conditioned space then cold water is circulated between the conditioned space and the plant, while hot water is circulated through the distribution system when heating is required. Since only water is transported to the conditioned space, provision must be there for supplying required amount of treated, outdoor air to the conditioned space for ventilation purposes. Depending upon the number of pipes used, the all water systems can be classified into a 2-pipe system or a 4-pipe system.

A 2-pipe system is used for either cooling only or heating only application, but cannot be used for simultaneous cooling and heating. Figure 36.6 shows the schematic of a 2-pipe, all water system. As shown in the figure and as the name implies, a 2-pipe system consists of two pipes – one for supply of cold/hot water to the conditioned space and the other for the return water. A cooling or heating coil provides the required cold or hot water. As the supply water flows through the conditioned space, required heat transfer between the water and conditioned space

takes place, and the return water flows back to the cooling or heating coil. A flow control valve controls the flow rate of hot or cold water to the conditioned space and thereby meets the required building heating or cooling load. The flow control valve is controlled by the zone thermostat. As already mentioned, a separate arrangement must be made for providing the required amount of ventilation air to the conditioned space. A pressure relief valve (PRV) is installed in the water line for maintaining balanced flow rate.

A 4-pipe system consists of two supply pipelines – one for cold water and one for hot water; and two return water pipelines. The cold and hot water are mixed in a required proportion depending upon the zone load, and the mixed water is supplied to the conditioned space. The return water is split into two streams, one stream flows to the heating coil while the other flows to the cooling coil.



**Fig.36.6:** A two-pipe, all water system

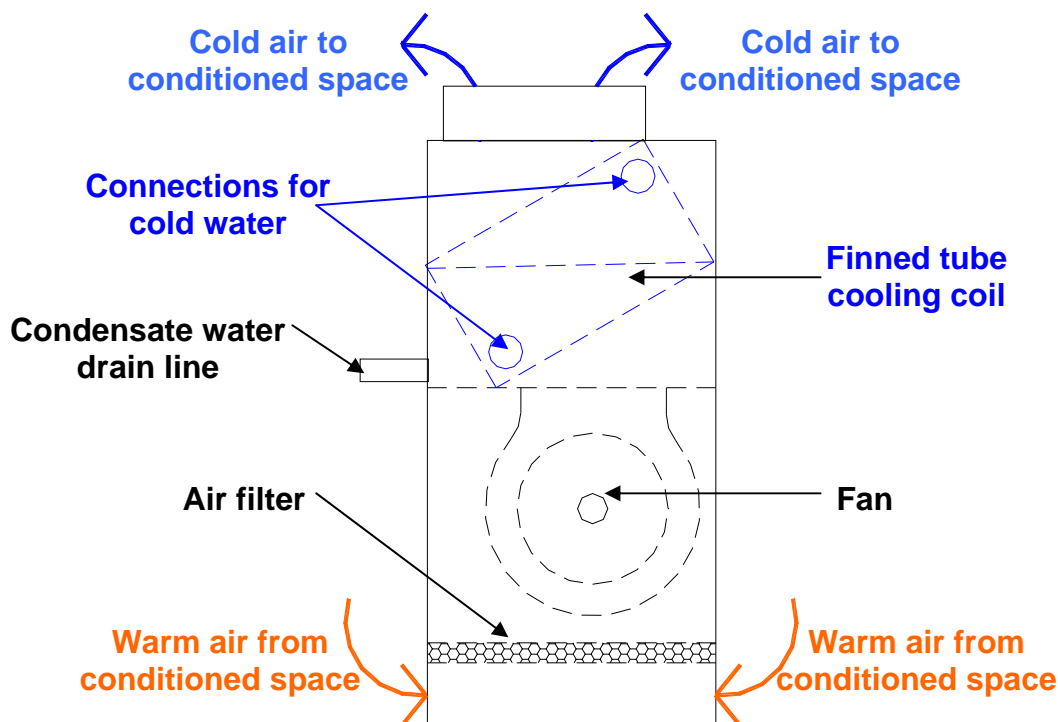
Heat transfer between the cold/hot water and the conditioned space takes place either by convection, conduction or radiation or a combination of these. The cold/hot water may flow through bare pipes located in the conditioned space or one of the following equipment can be used for transferring heat:

1. Fan coil units
2. Convectors
3. Radiators etc.

A fan coil unit is located inside the conditioned space and consists of a heating and/or cooling coil, a fan, air filter, drain tray and controls. Figure 36.7 shows the schematic of a fan coil unit used for cooling applications. As shown in the figure, the basic components of a fan coil unit are: finned tube cooling coil, fan, air filter, insulated drain tray with provision for draining condensate water and connections for



cold water lines. The cold water circulates through the finned tube coil while the blower draws warm air from the conditioned space and blows it over the cooling coil. As the air flows through the cooling coil it is cooled and dehumidified. The cold and dehumidified air is supplied to the conditioned space for providing required conditions inside the conditioned space. The water condensed due to dehumidification of room air has to be drained continuously. A cleanable or replaceable filter is located in the upstream of the fan to prevent dust accumulation on the cooling coil and also to protect the fan and motor from dust. Fan coil units for domestic air conditioning are available in the airflow range of 100 to 600 l/s, with multi-speed, high efficiency fans. In some designs, the fan coil unit also consists of a **heating coil**, which could be in the form of an **electric heater or steam or hot water coil**. Electric heater is used with 2-pipe systems, while the hot water/steam coils are



**Fig.36.7:** A basic fan coil unit for cooling purposes

used with 4-pipe systems. The fan coil units are either floor mounted, window mounted or ceiling mounted. The capacity of a fan coil unit can be controlled either by controlling the cold water flow rate or by controlling air flow rate or both. The airflow rate can be controlled either by a damper arrangement or by varying the fan speed. The control may be manual or automatic, in which case, a room thermostat controls the capacity. Since in the fan coil unit there is no provision for ventilation, a **separate arrangement must be made to take care of ventilation**. A fan coil unit with a provision for introducing treated ventilation air to the conditioned space is called as **unit ventilator**.

A **convector** consists of a finned tube coil through which hot or cold fluid flows. Heat transfer between the coil and surrounding air takes place by natural convection only, hence no fans are used for moving air. Convectors are very widely used for heating applications, and very rarely are used for cooling applications.

In a **radiator**, the heat transfer between the coil and the surrounding air is primarily by radiation. Some amount of heat is also transferred by natural convection. Radiators are widely used for heating applications, however, in recent times they are also being used for cooling applications.

### **36.5.1. Advantages of all water systems:**

1. The thermal distribution system requires very less space compared to all air systems. Thus there is no penalty in terms of conditioned floor space. Also the plant size will be small due to the absence of large supply air fans.
2. Individual room control is possible, and at the same time the system offers all the benefits of a large central system.
3. Since the temperature of hot water required for space heating is small, it is possible to use solar or waste heat for winter heating.
4. It can be used for new as well existing buildings (retrofitting).
5. Simultaneous cooling and heating is possible with 4-pipe systems.

### **36.5.2. Disadvantages of all water systems:**

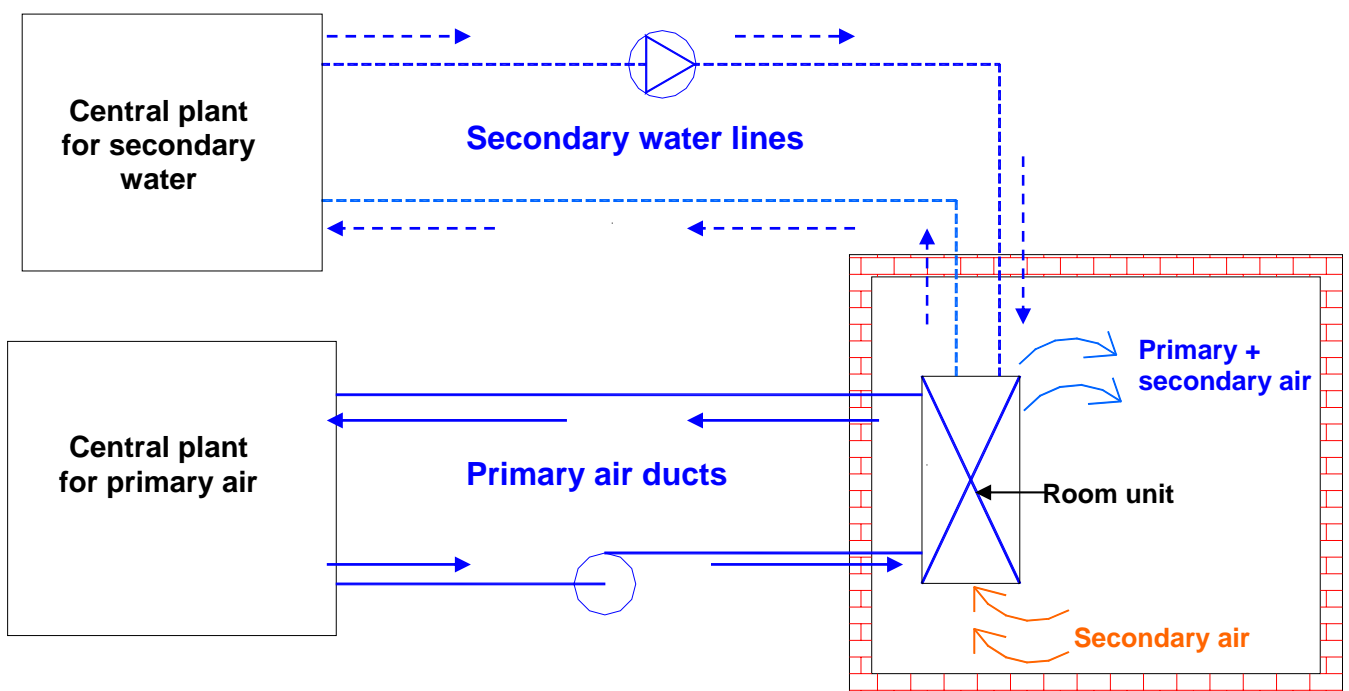
1. Requires higher maintenance compared to all air systems, particularly in the conditioned space.
2. Draining of condensate water can be messy and may also create health problems if water stagnates in the drain tray. This problem can be eliminated, if dehumidification is provided by a central ventilation system, and the cooling coil is used only for sensible cooling of room air.
3. If ventilation is provided by opening windows or wall apertures, then, it is difficult to ensure positive ventilation under all circumstances, as this depends on wind and stack effects.
4. Control of humidity, particularly during summer is difficult using chilled water control valves.

### **36.5.3. Applications of all water systems:**

All water systems using fan coil units are most suitable in **buildings requiring individual room control**, such as hotels, apartment buildings and office buildings.

## 36.6. Air-water systems:

In air-water systems both air and water are used for providing required conditions in the conditioned space. The air and water are cooled or heated in a central plant. The air supplied to the conditioned space from the central plant is called as **primary air**, while the water supplied from the plant is called as **secondary water**. The complete system consists of a central plant for cooling or heating of water and air, ducting system with fans for conveying air, water pipelines and pumps for conveying water and a **room terminal**. The room terminal may be in the form of a fan coil unit, an induction unit or a radiation panel. Figure 36.8 shows the schematic of a basic air-water system. Even though only one conditioned space is shown in the schematic, in actual systems, the air-water systems can simultaneously serve several conditioned spaces.



**Fig.36.8:** A basic air-water system

Normally a constant volume of primary air is supplied to each zone depending upon the ventilation requirement and the required sensible cooling capacity at maximum building load. For summer air conditioning, the primary air is cooled and dehumidified in the central plant, so that it can offset all the building latent load. Chilled water is supplied to the conditioned space to partly offset the building sensible cooling load only. Since the chilled water coil kept in the conditioned space has to take care of only sensible load, **condensation of room air inside the conditioned space is avoided** thereby avoiding the problems of condensate drainage and related problems in the conditioned space. As mentioned, the primary takes care of the ventilation requirement of the conditioned space, hence unlike in all water systems, there is no need for separate ventilation systems. **In winter**, moisture can be added to the primary air in the central plant and hot water is circulated through the coil kept in the conditioned space. The secondary water lines can be of 2-pipe, 3-pipe or 4-pipe type similar to all water systems.

As mentioned the room unit may be in the form of a fan coil unit, an induction unit or in the form of a radiant panel. In an induction unit the cooling/heating coil is an integral part of the primary air system. The **primary air** supplied at medium to high pressure to the induction unit, **induces flow of secondary air** from the conditioned space. The secondary air is sensibly cooled or heated as it flows through the cooling/heating coil. The primary and secondary air are mixed and supplied to the conditioned space. The fan coil units are similar to the ones used in all water systems.

### **36.6.1. Advantages of air-water systems:**

1. Individual zone control is possible in an economic manner using room thermostats, which control either the secondary water flow rate or the secondary air (in fan coil units) or both.
2. It is possible to provide simultaneous cooling and heating using primary air and secondary water.
3. Space requirement is reduced, as the amount of primary supplied is less than that of an all air systems.
4. Positive ventilation can be ensured under all conditions.
5. Since no latent heat transfer is required in the cooling coil kept in the conditioned space, the coil operates dry and its life thereby increases and problems related to odours or fungal growth in conditioned space is avoided.
6. The conditioned space can sometimes be heated with the help of the heating coil and secondary air, thus avoiding supply of primary air during winter.
7. Service of indoor units is relatively simpler compared to all water systems.

### **36.6.2. Disadvantages of air-water systems:**

1. Operation and control are complicated due to the need for handling and controlling both primary air and secondary water.
2. In general these systems are limited to perimeter zones.
3. The secondary water coils in the conditioned space can become dirty if the quality of filters used in the room units is not good.
4. Since a constant amount of primary air is supplied to conditioned space, and room control is only through the control of room cooling/heating coils, shutting down the supply of primary air to unoccupied spaces is not possible.
5. If there is abnormally high latent load on the building, then condensation may take place on the cooling coil of secondary water.

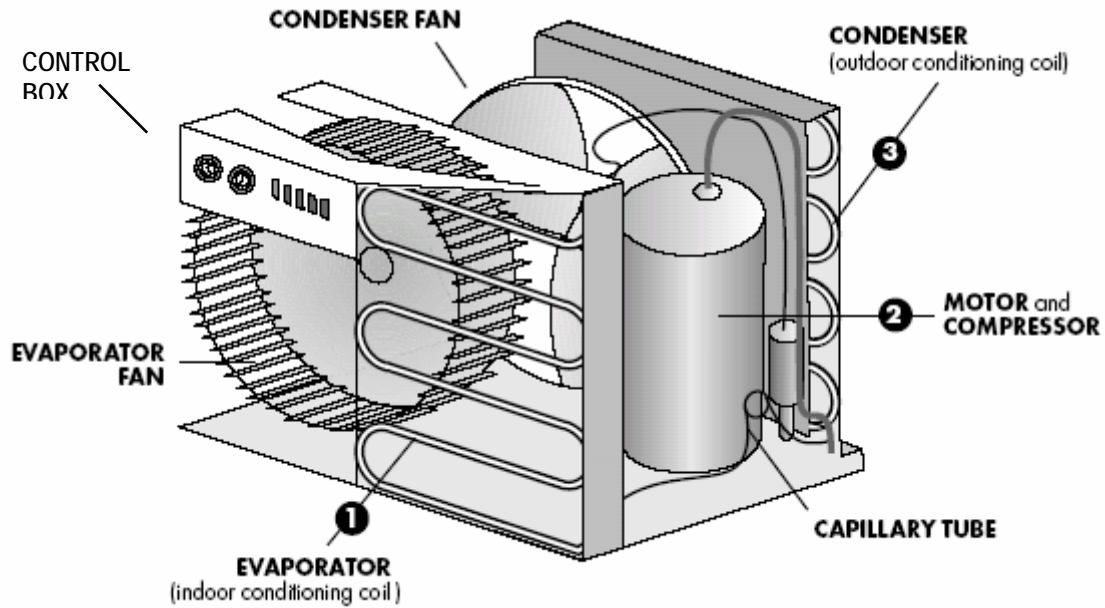
6. Initial cost could be high compared to all air systems.

### 36.6.3. Applications of air-water systems:

These systems are mainly used in **exterior buildings with large sensible loads** and where close control of humidity in the conditioned space is not required. These systems are thus suitable for office buildings, hospitals, schools, hotels, apartments etc.

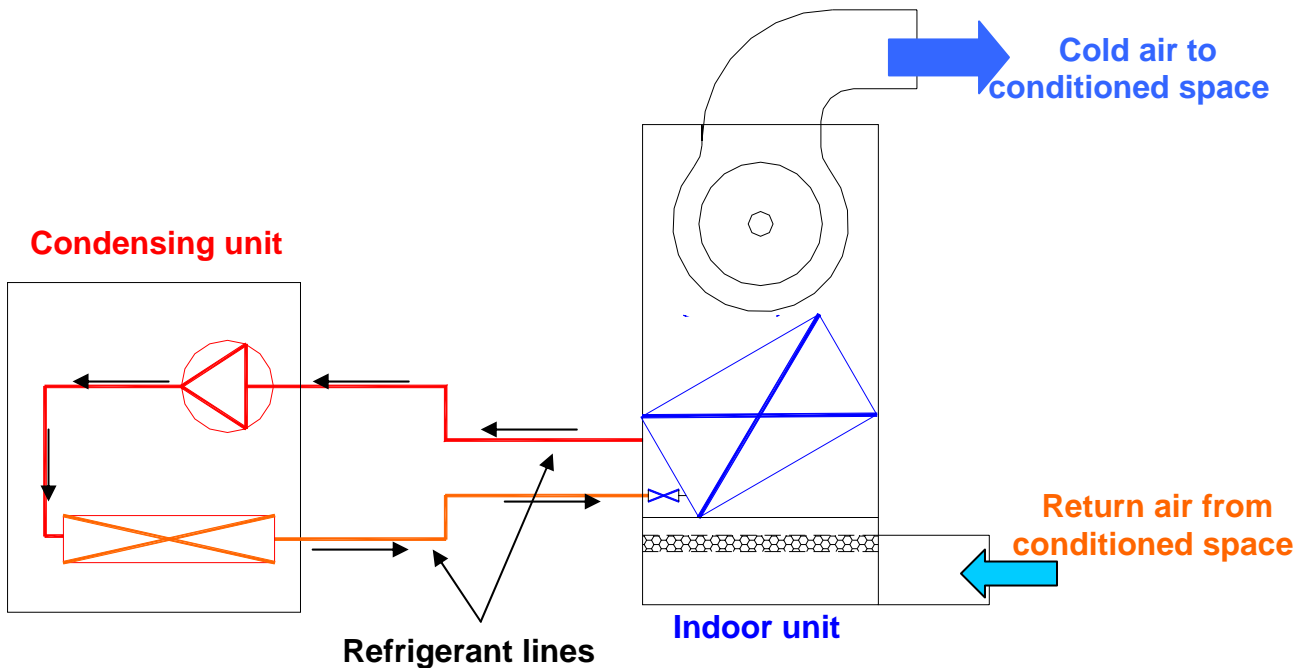
### 36.7. Unitary refrigerant based systems:

Unitary refrigerant based systems consist of several separate air conditioning units with individual refrigeration systems. These systems are **factory assembled and tested as per standard specifications**, and are available in the form of package units of varying capacity and type. Each package consists of refrigeration and/or heating units with fans, filters, controls etc. Depending upon the requirement these are available in the form of window air conditioners, split air conditioners, heat pumps, ductable systems with air cooled or water cooled condensing units etc. The capacities may range from **fraction of TR to about 100 TR for cooling**. Depending upon the capacity, unitary refrigerant based systems are available as single units which cater to a single conditioned space, or multiple units for several conditioned spaces. Figure 36.9 shows the schematic of a typical **window type, room air conditioner**, which is available in cooling capacities varying from about **0.3 TR to about 3.0 TR**. As the name implies, these units are normally mounted either in the window sill or through the wall. As shown in the figure, this type of unit consists of single package which includes the cooling and dehumidification coil, condenser coil, a hermetic compressor, expansion device (capillary tube), condenser fan, evaporator fan, room air filter and controls. A drain tray is provided at the bottom to take care of the condensate water. Both evaporator and condensers are plate fin-and-tube, forced convection type coils. For rooms that do not have external windows or walls, a **split type room air conditioner** can be used. In these air conditioners, the condensing unit comprising of the condenser, compressor and condenser fan with motor are located outside, while the indoor unit consisting of the evaporator, evaporator fan with motor, expansion valve and air filter is located inside the conditioned room. The indoor and outdoor units are connected by refrigerant piping. In split type air conditioners, the condensed water has to be taken away from the conditioned space using separate drain pipes. In the room air conditioners (both window mounted and split type), the cooling capacity is controlled by switching the compressor on-and-off. Sometimes, in addition to the on-and-off, the fan speed can also be regulated to have a modular control of capacity. It is also possible to switch off the refrigeration system completely and run only the blower for air circulation.



**Fig.36.9.** A typical window type room air conditioner

Figure 36.10 shows a typical package unit with a remote condensing unit. As shown, in a typical package unit, the remote condensing unit consists of the compressor and a condenser, while the indoor unit consists of the plate fin-and-tube type, evaporator, a blower, air filter, drain tray and an arrangement for connecting supply air and return air ducts. These units are available in capacities ranging from about **5 TR to upto about 100 TR**. The condenser used in these systems could be either air cooled or water cooled. This type of system can be used for providing air conditioning in a large room or it can cater to several small rooms with suitable supply and return ducts. It is also possible to house the entire refrigeration in a single package with connections for water lines to the water cooled condenser and supply and return air ducts. Larger systems are either constant air volume type or variable air volume type. They may also include heating coils along with the evaporator.



**Fig.36.10:** A typical package unit with remote condensing unit

Most of the unitary systems have a provision for supplying outdoor air for ventilation purposes. The type of control depends generally on the capacity of the unit. The control system could be as simple as a simple thermostat based on-off control as in room air conditioners to sophisticated microprocessor based control with multiple compressors or variable air volume control or a combination of both.

### 36.7.1. Advantages of unitary refrigerant based systems:

1. Individual room control is simple and inexpensive.
2. Each conditioned space has individual air distribution with simple adjustment by the occupants.
3. Performance of the system is guaranteed by the manufacturer.
4. System installation is simple and takes very less time.
5. Operation of the system is simple and there is no need for a trained operator.
6. Initial cost is normally low compared to central systems.
7. Retrofitting is easy as the required floor space is small.

### 36.7.2. Disadvantages of unitary refrigerant based systems:

1. As the components are selected and matched by the manufacturer, the system is less flexible in terms of air flow rate, condenser and evaporator sizes.
2. Power consumption per TR could be higher compared to central systems.

3. Close control of space humidity is generally difficult.
4. Noise level in the conditioned space could be higher.
5. Limited ventilation capabilities.
6. Systems are generally designed to meet the appliance standards, rather than the building standards.
7. May not be appealing aesthetically.
8. The space temperature may experience a swing if on-off control is used as in room air conditioners.
9. Limited options for controlling room air distribution.
10. Equipment life is relatively short.

### **36.7.3. Applications of unitary refrigerant based systems:**

Unitary refrigerant based systems are used where stringent control of conditioned space temperature and humidity is not required and where the initial cost should be low with a small lead time. These systems can be used for air conditioning **individual rooms to large office buildings, classrooms, hotels, shopping centers, nursing homes** etc. These systems are especially suited for existing building with a limitation on available floor space for air conditioning systems.

### **Questions and answers:**

1. Which of the following statements are TRUE?

- a) The function of a thermal distribution system is to transfer sensible and latent heat between the air conditioning plant and the conditioned space
- b) A thermal distribution system may also supply the required amount of fresh air to the conditioned space
- c) Only air flows through a thermal distribution system
- d) Air, water, refrigerant or any other fluid can flow through a thermal distribution system

**Ans.: a), b) and d)**

2. Selection of a suitable air conditioning system depends on:

- a) Type of the building
- b) Initial and running costs
- c) Reliability and serviceability
- d) All of the above



**Ans.: d)**

**3. Which of the following statements are TRUE?**

- a) A single zone, single duct, constant volume system can be used either for cooling or for heating, but not for both cooling and heating simultaneously
- b) The cooling capacity of a single zone, single duct, constant volume system is controlled by controlling the supply air temperature
- c) Single zone, single duct, constant volume systems are not suitable when the space conditions have to be controlled precisely
- d) Single zone, single duct, constant volume systems can be used for large single rooms only

**Ans.: a) and b)**

**4. Which of the following statements are TRUE?**

- a) Single duct, multiple zone, constant volume systems can be used for simultaneous cooling and heating applications
- b) Single duct, multiple zone, constant volume systems can be used for large buildings comprising of several offices
- c) Single duct, multiple zone, constant volume systems are energy efficient
- d) Single duct, multiple zone, constant volume systems always ensure proper ventilation

**Ans.: b) and d)**

**5. Which of the following statements are TRUE?**

- a) In single duct, variable air volume systems, the temperature of the supply air remains constant, but the supply air flow rate is varied depending upon the load
- b) Variable air volume systems generally consume less power compared to constant volume systems
- c) Variable air volume systems occupy less space compared to constant volume systems
- d) Variable air volume systems always ensure adequate ventilation and good room air distribution

**Ans.: a) and b)**

**6. Which of the following statements are TRUE?**

- a) Dual duct systems can provide simultaneous cooling and heating
- b) Dual duct systems are constant air volume systems
- c) Dual duct systems are energy efficient
- d) Dual duct systems occupy more space compared to single duct systems

**Ans.: a) and d)**

7. Which of the following statements are TRUE?

- a) In all air systems, the outdoor and re-circulated airflow rates are controlled independently
- b) In all air systems, it is sometimes possible to switch of the cooling coil and use only outdoor air for air conditioning
- c) All air systems are highly suitable for retrofitting applications
- d) All air systems generally ensure precise control of conditioned space

**Ans.: b) and d)**

8. Which of the following statements are TRUE?

- a) A two-pipe all water system can be used for simultaneous cooling and heating applications
- b) In all water systems, separate provision must be made for ventilation
- c) An all water system is easier to maintain compared to an all air system
- d) Precise control of room conditions is difficult using all water systems

**Ans.: b) and d)**

9. Which of the following statements are TRUE?

- a) All water systems are suitable in buildings requiring individual room control
- b) All water systems consume less space compared to all air systems
- c) All water systems offer lower initial and running costs
- d) All of the above

**Ans.: a) and b)**

10. Which of the following statements are TRUE?

- a) An air-water system uses both air and water in the thermal distribution system
- b) In an air-water system, all the latent load on the building is handled by the primary air only
- c) In an air-water system, the cooling coil kept in the conditioned space operates under dry conditions
- d) Compared to all water systems, an air-water system is difficult to maintain

**Ans.: a), b) and c)**

11. Which of the following statements are TRUE?

- a) Individual zone control is not possible in an air-water system
- b) Using an air-water system it is possible to ensure positive ventilation under all conditions
- c) Compared to all air and all water systems, the control of an air-water system is more complicated
- d) The initial cost of an air-water system could be higher compared to other systems

**Ans.: b), c) and d)**

**12.** Which of the following statements are TRUE?

- a) A fan coil unit is used with all water systems only
- b) A fan coil unit can be used either with an all water system or with an air-water system
- c) It is possible to control the cooling capacity by controlling either liquid flow rate or air flow rate in a fan coil unit
- d) A fan coil unit used in an all water system requires a provision for draining the condensed water

**Ans.: b), c) and d)**

**13.** Which of the following statements are TRUE?

- a) In a convector, heat transfer takes place by forced convection
- b) Convectors are commonly used for heating applications
- c) In a radiator, heat transfer takes place by both radiation and convection
- d) A unit ventilator is a fan coil unit with a provision for fresh air entry

**Ans.: b), c) and d)**

**14.** Which of the following statements are TRUE?

- a) Unitary refrigerant based systems are used for very small capacities only
- b) Unitary refrigerant based systems are available only for cooling applications
- c) Unitary systems are factory assembled with a performance guaranteed by the manufacturer
- d) Unitary systems are also called as package units

**Ans.: c) and d)**

**15.** Which of the following statements are TRUE?

- a) Small unitary systems have air cooled condensers, while larger systems can be either air cooled or water cooled
- b) A split type room air conditioner should be used when the room does not have an exterior wall
- c) A split type air conditioner is more reliable compared to a window air conditioner
- d) It is possible to provide fresh air in a window air conditioner, whereas this is not possible in a split air conditioner

**Ans.: a), b) and d)**

**16.** Which of the following statements are TRUE?

- a) In room air conditioners, the cooling capacity is generally controlled by switching the compressor on-and-off
- b) Compared to a central air conditioning system, the temperature swing obtained using a room air conditioner is higher
- c) Using room air conditioners, it is possible to control the indoor conditions precisely
- d) Large unitary systems can be used with limited ducting to serve several rooms simultaneously

**Ans.: a), b) and d)**

**17. Which of the following statements are TRUE?**

- a) Compared to central systems, the initial cost of a unitary system is less
- b) Unitary systems can be installed quickly and their operation is relatively simple
- c) Unitary systems consume less power compared to central systems of same capacity
- d) Unitary systems are ideal for retrofitting applications

**Ans.: a), b) and d)**

**18. Match the following:**

- |   |                      |
|---|----------------------|
| 1. A large indoor stadium                                 | a. All water systems |
| 2. Individual rooms of a large hotel                      | b. All air systems   |
| 3. An existing building with good ventilation requirement | c. Unitary systems   |
| 4. An existing, small office building                     | d. Air-water system  |

**Ans.: 1-b, 2-a, 3-d, 4-c**

**19. Match the following:**

- |                                     |                                      |
|-------------------------------------|--------------------------------------|
| 1. A large precision laboratory     | a. Variable air volume system        |
| 2. Perimeter zone of a building     | b. Constant air volume system        |
| 3. Simultaneous cooling and heating | c. Multiple zone, single duct system |
| 4. A large building complex         | d. Dual duct system                  |

**Ans.: 1-b, 2-a, 3-d, 4-c**

**20. Match the following:**

1. Electronic chip manufacturing unit
2. Interior room of an office
3. A bedroom with a north facing wall
4. A medium sized restaurant

- a. Window air conditioner
- b. Package unit
- c. All air system
- d. Split air conditioner

**Ans.: 1-c, 2-d, 3-a, 4-b**

# Lesson

37

## Transmission Of Air In Air Conditioning Ducts

## The specific objectives of this chapter are to:

1. Describe an Air Handling Unit (AHU) and its functions (*Section 37.1*)
2. Discuss the need for studying transmission aspects of air in air conditioning (*Section 37.2*)
3. Discuss airflow through air conditioning ducts, Bernoulli and modified Bernoulli equations, Static, dynamic, datum and total head, Fan Total Pressure (FTP) and power input to fan (*Section 37.3*)
4. Discuss estimation of pressure loss through air conditioning ducts (*Section 37.4*)
5. Estimation of frictional pressure drop of circular and rectangular ducts using friction charts and equations (*Section 37.4*)
6. Estimation of dynamic pressure drop in various types of fittings (*Section 37.5*)
7. Static regain (*Section 37.6*)

At the end of the lecture, the student should be able to:

1. Apply Bernoulli equation and modified Bernoulli equation to air conditioning ducts and estimate various pressure heads, pressure loss, FTP and fan power input
2. Estimate frictional pressure drops through circular and non-circular ducts using friction charts and equations
3. Estimate dynamic pressure drop through various fittings used in air conditioning ducts using tables, charts and equations
4. Define static regain and calculate static regain factor for various types of duct enlargements

### 37.1. Introduction:

In air conditioning systems that use air as the fluid in the thermal distribution system, it is essential to design the Air Handling Unit (AHU) properly. The primary function of an AHU is to transmit processed air from the air conditioning plant to the conditioned space and distribute it properly within the conditioned space. A typical AHU consists of:

1. A duct system that includes a supply air duct, return air duct, cooling and/or heating coils, humidifiers/dehumidifiers, air filters and dampers
2. An air distribution system comprising various types of outlets for supply air and inlets for return air

3. Supply and return air fans which provide the necessary energy to move the air throughout the system

### 37.2. Transmission of air:

In an AHU, air is transmitted through various ducts and other components with the help of fans. Since the fan motor consumes a large amount of power, and the duct system occupies considerable building space, the design of air transmission system is an important step in the complete design of air conditioning systems. In the end the success of any air conditioning system depends on the design of individual components as well as a good matching between them under all conditions. In order to design the system for transmission of air, it is important to understand the fundamentals of fluid (air) flow through ducts. These aspects have been dealt with to some extent in Chapter 6 on Fundamentals of Fluid Flow.

### 37.3. Flow of air through ducts:

As mentioned in Chapter 6, the fundamental equation to be used in the analysis of air conditioning ducts is the Bernoulli's equation. Bernoulli's equation is **valid between any two points in the flow field** when the **flow is steady, irrotational, inviscid and incompressible**. The equation is **valid along a streamline for rotational, steady and incompressible flows**. Between any two points 1 and 2 in the flow field for irrotational flows, the Bernoulli's equation is written as:

$$\frac{p_1}{\rho g} + \frac{V_1^2}{2g} + z_1 = \frac{p_2}{\rho g} + \frac{V_2^2}{2g} + z_2 = \frac{p_T}{\rho g} = \text{total head} \quad (37.1)$$

where  $\frac{p}{\rho g}$  is the pressure head,  $\frac{V^2}{2g}$  is the velocity head and  $Z$  is the static head, respectively. Each of the heads has units of length as explained before. The above equation can be written in terms of static, velocity, datum and total pressures as:

$$p_1 + \frac{\rho V_1^2}{2} + \rho g z_1 = p_2 + \frac{\rho V_2^2}{2} + \rho g z_2 = p_T = \text{total pressure} \quad (37.2)$$

The above equation implies that for frictionless flow through a duct, the total pressure remains constant along the duct. Since **all real fluids have finite viscosity**, i.e. in all actual fluid flows, some energy will be lost in overcoming friction. This is referred to as **head loss**, i.e. if the fluid were to rise in a vertical pipe it will rise to a lower height than predicted by Bernoulli's equation. The head loss will cause the total pressure to decrease in the flow direction. If the head loss is denoted by  $H_l$ , then Bernoulli's equation can be modified to:

$$\frac{p_1}{\rho g} + \frac{V_1^2}{2g} + z_1 = \frac{p_2}{\rho g} + \frac{V_2^2}{2g} + z_2 + H_l \quad (37.3)$$

To overcome the fluid friction and the resulting head, a fan is required in air conditioning systems. When a fan is introduced into the duct through which air is flowing, then the static and total pressures at the section where the fan is located



rise. This rise is called as **Fan Total Pressure (FTP)**. Then the required power input to the fan is given by:

$$W_{\text{fan}} = \frac{\dot{Q}_{\text{air}} \cdot \text{FTP}}{\eta_{\text{fan}}} \quad (37.4)$$

The FTP should be such that it overcomes the pressure drop of air as it flows through the duct and the air finally enters the conditioned space with sufficient momentum so that a good air distribution can be obtained in the conditioned space. Evaluation of FTP is important in the selection of a suitable fan for a given application. It can be easily shown that when applied between any two sections 1 and 2 of the duct, in which the fan is located, the FTP is given by:

$$\text{FTP} = (p_2 - p_1) + \frac{\rho(V_2^2 - V_1^2)}{2g} + \rho g(z_2 - z_1) + \rho g H_l \quad (37.5)$$

Thus to evaluate FTP, one needs to know the static pressures at sections 1 and 2 ( $p_1, p_2$ ), air velocities at 1 and 2 ( $V_1, V_2$ ), datum at 1 and 2 ( $Z_1, Z_2$ ) and the head loss  $H_l$ . Normally, compared to the other terms, the pressure change due to datum  $\rho g(z_2 - z_1)$  is negligible. If the static pressures at the inlet and exit are equal, say, to atmospheric pressure ( $p_1 = p_2 = p_{\text{atm}}$ ) and the duct has a uniform cross section ( $v_1 = v_2$ ), then FTP is equal to the pressure loss due to friction. Thus to find FTP, one has to estimate the total pressure loss as air flows through the duct from one section to other.

### 37.4. Estimation of pressure loss in ducts:

As air flows through a duct its total pressure drops in the direction of flow. The pressure drop is due to:

1. Fluid friction
2. Momentum change due to change of direction and/or velocity

The pressure drop due to friction is known as **frictional pressure drop or friction loss,  $\Delta p_f$** . The pressure drop due to momentum change is known as **momentum pressure drop or dynamic loss,  $\Delta p_d$** . Thus the total pressure drop  $\Delta p_t$  is given by:

$$\Delta p_t = \Delta p_f + \Delta p_d \quad (37.6)$$

#### 37.4.1. Evaluation of frictional pressure drop in ducts

The Darcy-Weisbach equation is one of the most commonly used equations for estimating frictional pressure drops in internal flows. This equation is given by:

$$\Delta p_f = f \frac{L}{D} \left( \frac{\rho V^2}{2} \right) \quad (37.7)$$

where  $f$  is the dimensionless friction factor,  $L$  is the length of the duct and  $D$  is the diameter in case of a circular duct and hydraulic diameter in case of a non-circular duct. The friction factor is a function of **Reynolds number**,  $Re_D = \left( \frac{\rho V D}{\mu} \right)$  and the relative surface roughness of the pipe or duct surface in contact with the fluid.

**For turbulent flow**, the friction factor can be evaluated using the empirical correlation suggested by Colebrook and White is used, the correlation is given by:

$$\frac{1}{\sqrt{f}} = -2 \log_{10} \left[ \frac{k_s}{3.7D} + \frac{2.51}{(Re_D)\sqrt{f}} \right] \quad (37.8)$$

where  $k_s$  is the average surface roughness of inner duct expressed in same units as the diameter  $D$ . Evaluation of  $f$  from the above equation requires iteration since  $f$  occurs on both the sides of it.

In general in air conditioning ducts, the fluid flow is turbulent. It is seen from the above equation that when the flow is turbulent, the friction factor is a function of Reynolds number, hydraulic diameter and inner surface roughness of the duct material. Table 37.1 shows absolute roughness values of some of the materials commonly used in air conditioning:

Material	Absolute roughness , $\epsilon$ (m)
Galvanized Iron (GI) sheet	0.00015
Concrete	0.0003 to 0.003
Riveted steel	0.0009 to 0.009
Cast Iron (CI)	0.00026
Commercial steel	0.00046

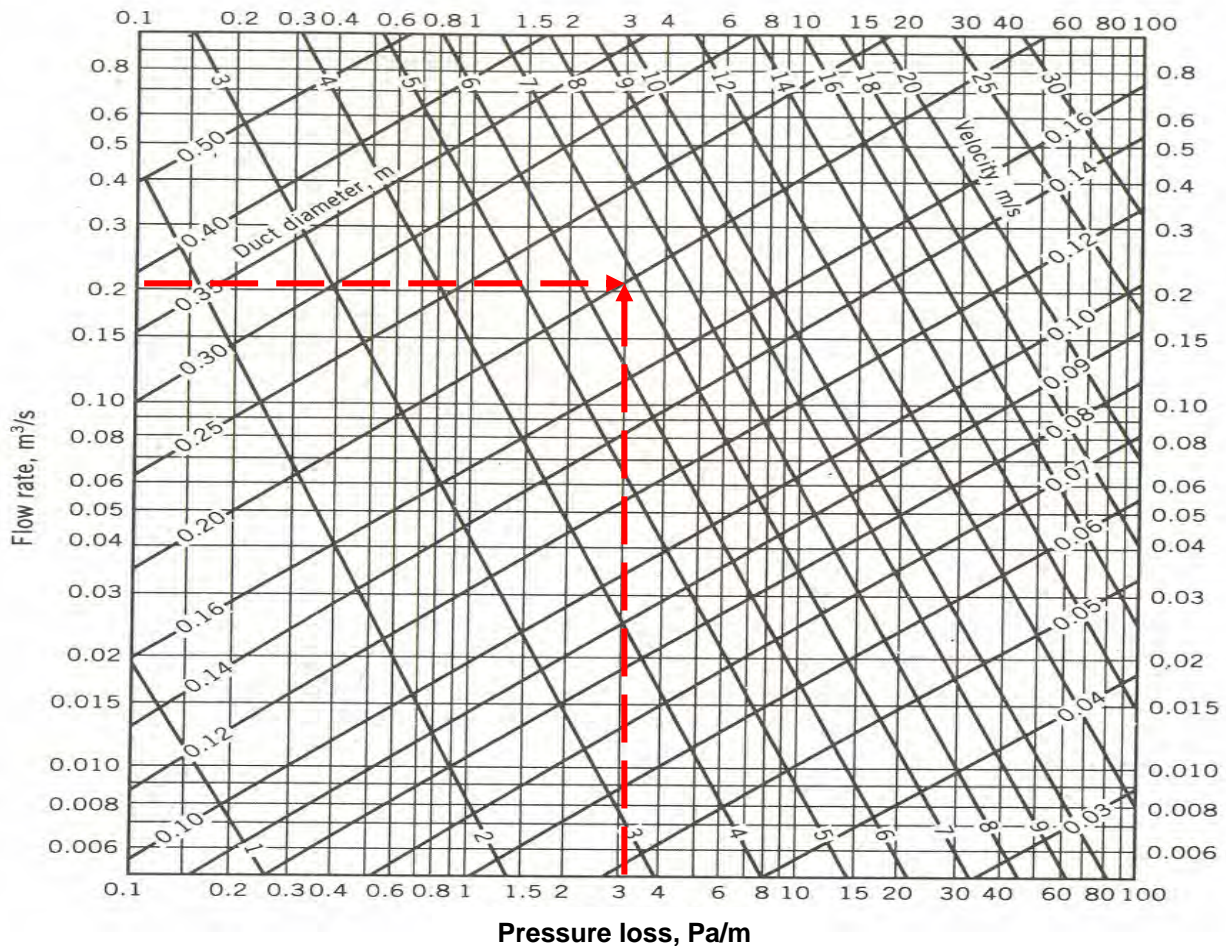
**Table 37.1:** Average surface roughness of commonly used duct materials

Of the different materials, the GI sheet material is very widely used for air conditioning ducts. Taking **GI as the reference material** and properties of air at 20°C and 1 atm. pressure, the frictional pressure drop in a circular duct is given by:

$$\Delta p_f = \frac{0.022243 \dot{Q}_{air}^{1.852} L}{D^{4.973}} \quad \text{in N/m}^2 \quad (37.9)$$

where  $\dot{Q}_{air}$  is the volumetric flow rate of air in  $m^3/s$ ,  $L$  is the length and  $D$  is the inner diameter of the duct in meters, respectively.

Using the above equation, friction charts have been created for estimation of frictional pressure drop of standard air through circular ducts made of GI sheets. Figure 37.1 shows the standard chart for estimating frictional pressure drop in circular ducts made of GI sheets at standard air conditions.



**Fig.37.1.** Chart for estimating frictional pressure drop in circular GI ducts

It can be seen from the chart that one can estimate frictional pressure drop per unit length if any two parameters out of the three parameters, i.e., flow rate  $\dot{Q}_{\text{air}}$ , diameter  $D$  and velocity  $V$  are known. Correction factors have to be applied to the pressure drop values for ducts made of other materials and/or for air at other conditions. For small changes in air density ( $\rho$ ) and temperature ( $T$  in K), one can use the following relation to obtain frictional pressure drop from the standard chart.

$$\left( \frac{\Delta p_{f,1}}{\Delta p_{f,2}} \right) = \left( \frac{\rho_1}{\rho_2} \right) \quad \text{and} \quad \left( \frac{\Delta p_{f,1}}{\Delta p_{f,2}} \right) = \left( \frac{T_2}{T_1} \right)^{0.857} \quad (37.10)$$

The chart shown above is valid only for circular ducts. For other shapes, an equivalent diameter has to be used to estimate the frictional pressure drop.

### 37.4.2. Rectangular ducts:

Even though circular ducts require the least material for a given flow rate and allowable pressure drop, **rectangular ducts are generally preferred** in practice as they fit easily into the building construction thus occupying less space, and they are also easy to fabricate. The ratio of the two sides 'a' and 'b' of the rectangle (a/b) is called as aspect ratio of the duct. Since square ducts with aspect ratio 1.0 come close in performance to a circular duct, it is preferable to use an aspect ratio as close to unity as possible for best performance.

One can use equation (37.9) and friction chart for circular ducts for estimating pressure drop through a rectangular duct by using an equivalent diameter. **A rectangular duct is said to be equivalent to a circular duct, if the volumetric flow rate  $\dot{Q}_{air}$  and frictional pressure drop per unit length ( $\Delta P_f/L$ ) are same for both.** Equating these two parameters for a rectangular duct and an equivalent circular duct, it can be shown that the equivalent diameter is given by:

$$D_{eq} = 1.3 \frac{(ab)^{0.625}}{(a+b)^{0.25}} \quad (37.11)$$

The above equation is found to be **valid for aspect ratio less than or equal to 1:8**. Thus from the known values of the two sides of the duct 'a' and 'b', one can find the equivalent diameter  $D_{eq}$ . From the equivalent diameter and the air flow rate, one can estimate the frictional pressure drop per unit length by using either Eq.(37.9) or the friction chart Fig. 37.1. However, when using equivalent diameter and flow rate to find the frictional pressure drop from the chart, the velocity values shown on the chart are not the actual velocities. **The actual velocities have to be obtained from the flow rate and the actual cross-sectional area of the rectangular duct.** If a rectangular duct has to be designed for a given flow rate and a given frictional pressure drop, then one can first find the equivalent diameter from the friction chart or from Eq.(37.9) and then find the required dimensions of the duct either by fixing the aspect ratio or one of the sides.

### 37.5. Dynamic losses in ducts:

Dynamic pressure loss takes place whenever there is a change in either the velocity or direction of airflow due to the use of a variety of bends and fittings in air conditioning ducts. Some of the commonly used fittings are: **enlargements, contractions, elbows, branches, dampers etc.** Since in general these fittings and bends are rather short in length (< 1 m), the major pressure drop as air flows through these fittings is not because of viscous drag (friction) but due to momentum change. Pressure drop in bends and fittings could be considerable, and hence should be evaluated properly. However, exact analytical evaluation of dynamic pressure drop through actual bends and fittings is quite complex. Hence for almost all the cases, the dynamic losses are determined from experimental data. In turbulent flows, the dynamic loss is proportional to square of velocity. Hence these are expressed as:

$$\Delta p_d = K \frac{\rho V^2}{2} \quad (37.12)$$

where  $K$  is the dynamic loss coefficient, which is normally obtained from experiments.

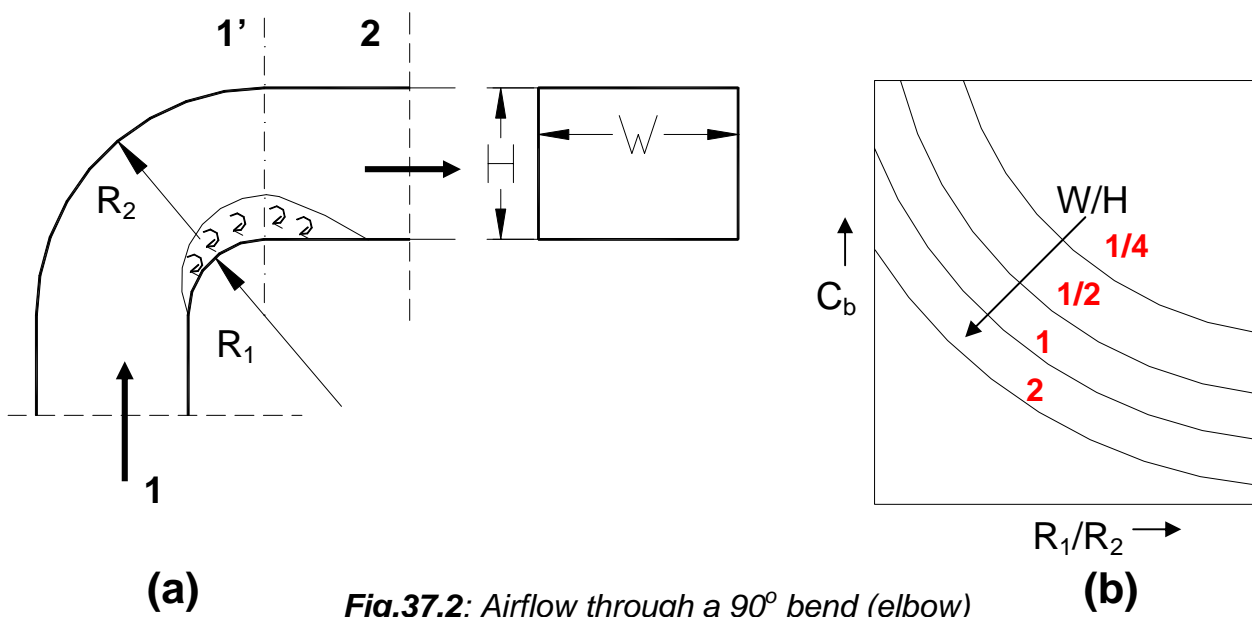
Sometimes, an equivalent length  $L_{eq}$  is defined to estimate the dynamic pressure loss through bends and fittings. The dynamic pressure loss is obtained from the equivalent length and the frictional pressure drop equation or chart, i.e.,

$$\Delta p_d = K \left( \frac{\rho V^2}{2} \right) = \left( \frac{f \cdot L_{eq}}{D_{eq}} \right) \left( \frac{\rho V^2}{2} \right) \quad (37.13)$$

where  $f$  is the friction factor and  $L_{eq}$  is the equivalent length.

### 37.5.1. Evaluation of dynamic pressure loss through various fittings:

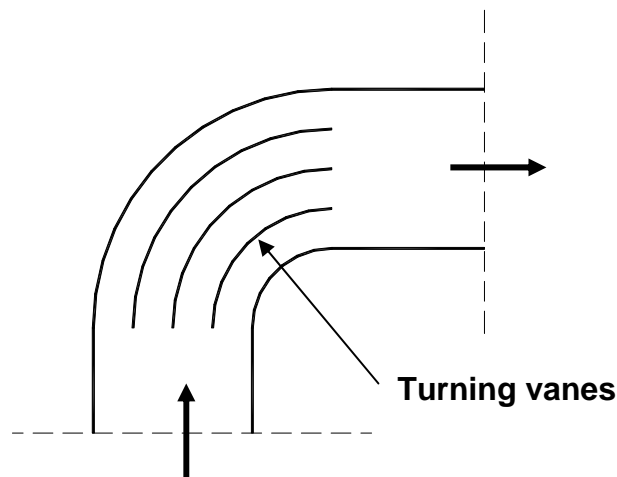
**a) Turns, bends or elbows:** The most common type of bends used in air conditioning ducts are  $90^\circ$  turns shown in Fig. 37.2(a).



The cross-section of the elbow could be circular or rectangular. Weisbach proposed that the dynamic pressure loss in an elbow is due to the sudden expansion from the *vena contracta* region (1') to full cross-section 2 as shown in Fig.37.2(a). The dynamic pressure drop due to the elbow or  $90^\circ$  turn is found to be a function of the aspect ratio ( $W/H$ ), inner and outer radii of the turn ( $R_1$  and  $R_2$ ) and the velocity pressure  $\rho V^2/2$ , i.e.,

$$\Delta p_{d,b} = C_b \left( \frac{\rho V^2}{2} \right) = f((W/H), R_1, R_2) \left( \frac{\rho V^2}{2} \right) \quad (37.14)$$

The value of dynamic loss coefficient  $C_b$  as a function of aspect ratio ( $W/H$ ), inner and outer radii of the turn ( $R_1$  and  $R_2$ ) is available in the form of tables and graphs (Fig.37.2(b)). It can be seen from Fig. 37.2(b) that the pressure loss increases as  $(R_1/R_2)$  decreases and/or the aspect ratio  $W/H$  decreases. As a result, installing turning vanes in the bends reduces the dynamic pressure drop as it is equivalent to increasing  $W/H$ , as shown in Fig. 37.2(c).



**Fig.37.2(c): Use of turning vanes in a 90° bend (elbow)**

The equivalent lengths are available as function of geometry for other types of turns and bends.

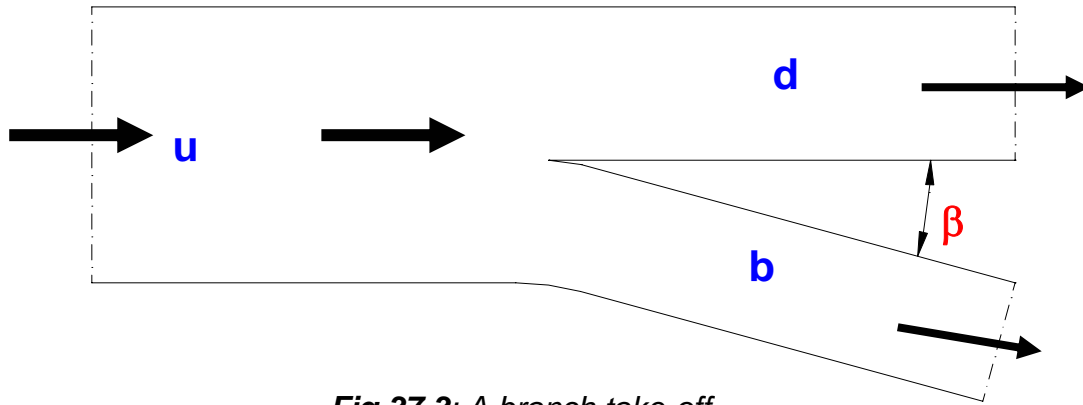
**b) Branch take-offs:** Branch take-offs (Fig. 37.3) are commonly used in air conditioning ducts for splitting the airflow into a branch and a downstream duct. The dynamic pressure drop from the upstream (u) to downstream (d),  $\Delta p_{u-d}$  is given by:

$$\Delta p_{u-d} = 0.4 \left( \frac{\rho V_d^2}{2} \right) \left( 1 - \frac{V_d}{V_u} \right)^2 \quad (37.15)$$

where  $V_d$  and  $V_u$  are the air velocities in the downstream and upstream ducts, respectively.

The dynamic pressure drop from the upstream (u) to branch (b),  $\Delta p_{u-b}$  is given by:

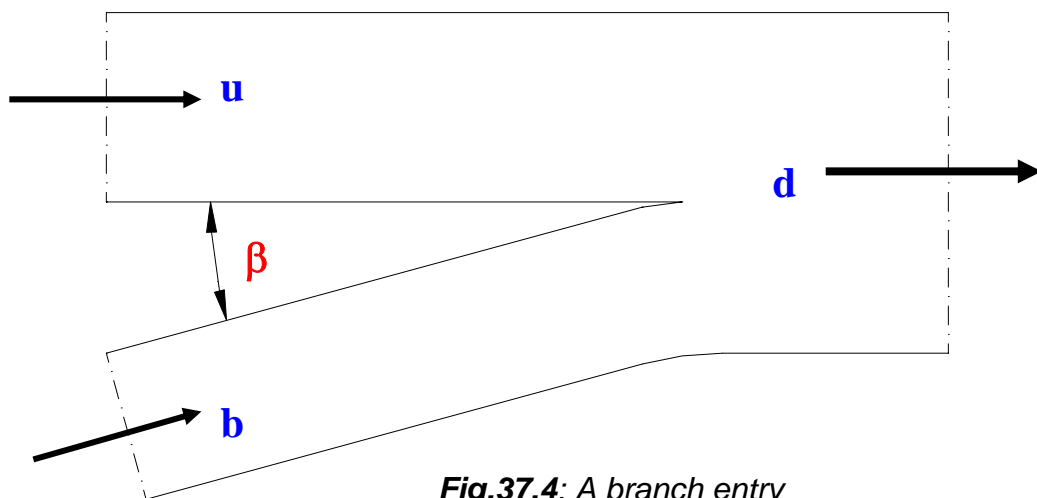
$$\Delta p_{u-b} = C_{u-b} \left( \frac{\rho V_d^2}{2} \right) \quad (37.16)$$



**Fig.37.3:** A branch take-off

The value of dynamic loss coefficient  $C_{u-b}$  is available in the form of tables and graphs as a function of the angle  $\beta$  and the ratio of branch-to-upstream velocity,  $V_b/V_u$ .  $C_{u-b}$  is found to increase as  $\beta$  and  $V_b/V_u$  increase.

**c) Branch entries:** Branch entries (Fig. 37.4) are commonly used in return air ducts. Similar to branch take-offs, the values of dynamic pressure loss coefficients from upstream-to-downstream ( $C_{u-d}$ ) and from branch-to-downstream ( $C_{u-d}$ ) are available in the form of tables and graphs as functions of upstream, branch and downstream velocities and the angle  $\beta$ .



**Fig.37.4:** A branch entry

**d) Sudden enlargement:** The pressure loss due to sudden enlargement, shown in Fig. 37.5(a),  $\Delta P_{d,enl}$  is given by **Borda-Carnot equation** as:

$$\Delta p_{d,enl} = \left( \frac{\rho V_1^2}{2} \right) \left( 1 - \frac{A_1}{A_2} \right)^2 \quad (37.17)$$

where  $V_1$  is the velocity before enlargement, and  $A_1$  and  $A_2$  are the areas before and after enlargement, respectively. The above expression, which is obtained analytically using modified Bernouille's equation and momentum balance equation is found to

over-predict the pressure loss when the air flow rates are high and under-predict when the flow rate is low. Correction factors are available in the form of tables for different enlargements.

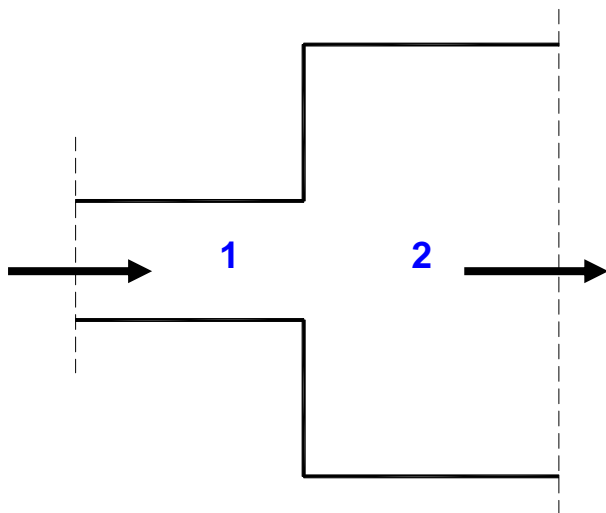


Fig.37.5(a): Sudden enlargement

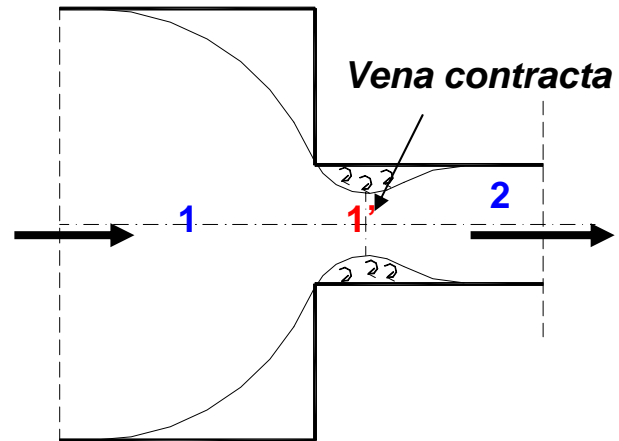


Fig.37.5(b): Sudden contraction

**e) Sudden contraction:** A sudden contraction is shown in Fig. 37.5(b). Similar to sudden enlargement, the dynamic pressure loss due to sudden contraction  $\Delta P_{d,con}$  can be obtained analytically. This expression is also known as Borda-Carnot equation. It is given by:

$$\Delta p_{d,con} = \left( \frac{\rho V_2^2}{2} \right) \left( \frac{A_2}{A_{1'}} - 1 \right)^2 = \left( \frac{\rho V_2^2}{2} \right) \left( \frac{1}{C_c} - 1 \right)^2 \quad (37.18)$$

where  $V_2$  is the velocity in the downstream, and  $A_{1'}$  and  $A_2$  are the areas at *vena contracta* and after contraction, respectively. The coefficient  $C_c$  is known as contraction coefficient and is seen to be equal to area ratio  $A_{1'}/A_2$ . The contraction coefficient  $C_c$  is found to be a function of the area ratio  $A_2/A_1$ , and the values of  $C_c$  as obtained by Weisbach are shown in Table 37.3.

$A_2/A_1$	$C_c$
0.1	0.624
0.5	0.681
0.8	0.813
1.0	1.000

Table 37.3: Values of contraction coefficient  $C_c$  for different area ratios

Comparing the expressions of pressure loss for sudden enlargement and sudden contraction, it can be seen that for the same flow rates and area ratios, the



pressure drop due to sudden enlargement is higher than that due to sudden contraction.

**f) Miscellaneous fittings, openings etc.:** The dynamic pressure loss coefficients for other types of fittings, such as suction and discharge openings are also available in the form of tables. These values depend on the design of the fitting/opening. For abrupt suction opening the dynamic loss coefficient (K) is found to be about 0.85, while it is about 0.03 for a formed entrance. For discharge openings where the downstream pressure is atmospheric, all the kinetic energy of the air stream is dissipated at the exit, hence, the dynamic loss coefficient is equal to 1.0 in this case.

**Filters, cooling and heating coils, dampers etc.:** The pressure drop across air handling unit equipment, such as, air filters, dampers, cooling and heating coils depend on several factors. Hence, normally these values have to be obtained from the manufacturer's data.

### 37.6. Static regain:

Whenever there is an enlargement in the cross-sectional area of the duct, the velocity of air decreases, and the velocity pressure is converted into static pressure. The **increase in static pressure due to a decrease in velocity pressure is known as static regain**. In an ideal case, when there are no pressure losses, the increase in static pressure ( $\Delta p_s$ ) is exactly equal to the decrease in velocity pressure ( $\Delta p_v$ ) and the total pressure ( $p_t$ ) remains constant as shown in Fig.37.6(a). Thus for the ideal case:

$$\begin{aligned}\Delta p_v &= p_{v,1} - p_{v,2} = \Delta p_s = p_{s,2} - p_{s,1} \\ p_{t,1} &= p_{t,2}\end{aligned}\tag{37.19}$$

However, for sudden enlargements or for other non-ideal enlargements, the decrease in velocity pressure will be greater than the increase in static pressure, and the total pressure decreases in the direction flow due to pressure losses as shown in Fig. 37.6(b). The pressure loss is due to separation of the boundary layer and the formation of eddies as shown in Fig.37.6(b). Thus, for sudden or non-ideal enlargement:

$$\begin{aligned}\Delta p_v &= p_{v,1} - p_{v,2} > \Delta p_s = p_{s,2} - p_{s,1} \\ p_{t,1} &= p_{t,2} + \Delta p_{\text{loss}}\end{aligned}\tag{37.20}$$

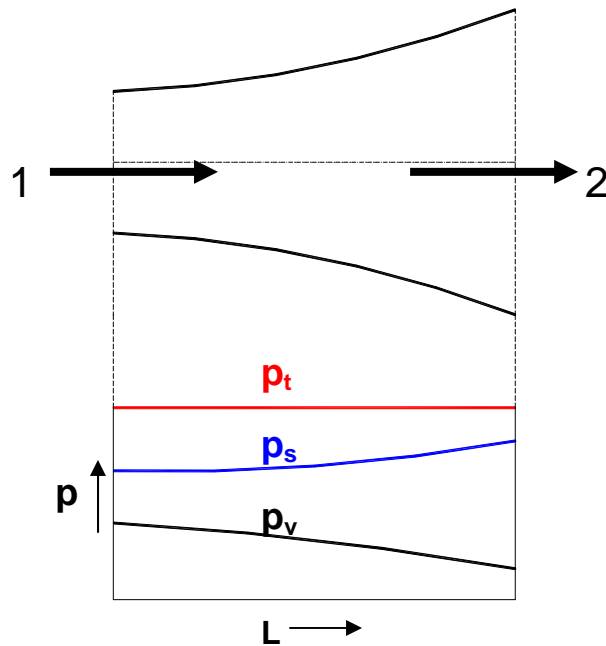
The pressure loss due to enlargement  $\Delta p_{\text{loss}}$  is expressed in terms of a Static Regain Factor, R as:

$$\Delta p_{\text{loss}} = (1 - R)\Delta p_v = (1 - R)(p_{v,1} - p_{v,2})\tag{37.21}$$

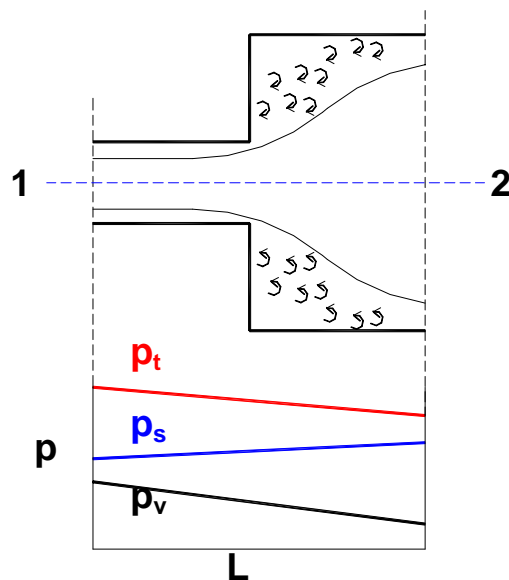
where the static regain factor R is given by:

$$R = \frac{\Delta p_s}{\Delta p_v} = \frac{(p_{s,2} - p_{s,1})}{(p_{v,1} - p_{v,2})} \quad (37.21)$$

Thus for ideal enlargement the Static Regain Factor R is equal to 1.0, whereas it is less than 1.0 for non-ideal enlargement.



*Fig.37.6(a): Ideal enlargement*



*Fig.37.6(b): Sudden enlargement*

## Questions and answers:

1. State which of the following statements are TRUE?

- a) An air handling unit conveys air between the conditioned space and the plant
- b) An air handling unit consists of supply and return air fans
- c) The fan used in an air conditioning system consumes large amount of power
- d) All of the above

**Ans.: d)**

2. State which of the following statements are TRUE?

- a) Under ideal conditions, the static pressure through an air conditioning duct remains constant
- b) Under ideal conditions, the total pressure through an air conditioning duct remains constant
- c) A fan is required in an air conditioning duct to overcome static pressure loss
- d) A fan is required in an air conditioning duct to overcome total pressure loss

**Ans.: b) and d)**

3. State which of the following statements are TRUE?

- a) In a duct of uniform cross section, the static pressure remains constant
- b) In a duct of uniform cross section, the static pressure decreases along length
- c) In a duct of uniform cross section, the total pressure decreases along length
- d) In a duct of uniform cross section, the dynamic pressure remains constant

**Ans.: b), c) and d)**

4. State which of the following statements are TRUE?

- a) The pressure drop in an air conditioning duct is due to frictional effects
- b) The pressure drop in an air conditioning duct is due to friction as well as momentum change
- c) Frictional pressure drop increases with duct length
- d) Momentum pressure drop takes place over relatively short lengths

**Ans.: b), c) and d)**

5. Rectangular ducts are generally preferred over circular ducts in buildings as:

- a) For a given flow rate, the pressure drop is less compared to a circular duct
- b) For a given pressure drop, it requires less material compared to a circular duct
- c) Rectangular ducts are easier to fabricate
- d) Rectangular ducts match better with building profile

**Ans.: c) and d)**

6. State which of the following statements are TRUE?

- a) Dynamic pressure drop in an elbow of rectangular cross-section reduces as the aspect ratio increases
- b) Use of turning vanes increase the aspect ratio
- c) Compared to sudden enlargement, the dynamic pressure drop in sudden contraction is less
- d) Compared to sudden enlargement, the dynamic pressure drop in sudden contraction is more

**Ans.: a), b) and c)**

7. State which of the following statements are TRUE?

- a) The static regain factor always lies between 0 and 1
- b) The static regain factor is 0 for an ideal enlargement
- c) The static regain factor is 1 for an ideal enlargement
- d) In an actual enlargement, reduction in dynamic pressure is always greater than increase in static pressure

**Ans.: a), c) and d)**

8. 1 m<sup>3</sup>/s of air is conveyed through a straight, horizontal duct of uniform cross-section and a length of 40 m. If the velocity of air through the duct is 5 m/s, find the required fan power input when a) A circular duct is used, and b) A rectangular duct of aspect ratio 1:4 is used. Take the efficiency of the fan to be 0.7. If a GI sheet of 0.5 mm thick with a density of 8000 kg/m<sup>3</sup> is used to construct the duct, how many kilograms of sheet metal is required for circular and rectangular cross sections? Assume standard conditions and the static pressure at the inlet and exit of the duct to be same.

**Ans.:** From continuity equation; the required cross-sectional area of the duct is given by:

$$A_{cs} = (\text{Flow rate, } Q/\text{Velocity, } V) = (1.0/5.0) = 0.2 \text{ m}^2$$

a) Circular duct:

$$\text{The required diameter of the duct, } D = (4A_{cs}/\pi) = 0.50463 \text{ m}$$

Then using the equation for frictional pressure drop;

$$\Delta p_f = \frac{0.022243 \dot{Q}_{air}^{1.852} L}{D^{4.973}} = \frac{0.022243 (1.0)^{1.852} 40}{(0.50463)^{4.973}} = 26.7 \text{ N/m}^2$$

Since the duct is straight, the dynamic pressure drop is zero in the absence of any fittings, hence:

**Fan Total Pressure, FTP =  $\Delta P_f = 26.7 \text{ N/m}^2$**

Hence the required fan power input,  $W_{fan}$  is:

$$W_{fan} = \frac{\dot{Q}_{air} \cdot FTP}{\eta_{fan}} = \frac{1.0 \times 26.7}{0.7} = 38.14 \text{ W} \quad (\text{Ans.})$$

The required mass of the duct is given by:

$$m_{circular} = (\pi D) \times (\text{thickness}) \times (\text{density}) = 6.34 \text{ kg} \quad (\text{Ans.})$$

b) Rectangular duct: of aspect ratio (a:b) = (1:4)

As before, cross sectional area,  $A_{cs} = 0.2 \text{ m}^2 = a \times b = a \times 4a$

$$\Rightarrow a = 0.22361 \text{ m and } b = 4a = 0.89440 \text{ m}$$

The equivalent diameter,  $D_{eq}$  is given by:

$$D_{eq} = 1.3 \frac{(ab)^{0.625}}{(a+b)^{0.25}} = 1.3 \frac{(0.2)^{0.625}}{(0.22361 + 0.8944)^{0.25}} = 0.46236 \text{ m}$$

Using the friction equation, the frictional pressure drop is:

$$\Delta p_f = \frac{0.022243 \dot{Q}_{air}^{1.852} L}{D^{4.973}} = \frac{0.022243 (1.0)^{1.852} 40}{(0.46236)^{4.973}} = 41.24 \text{ N/m}^2$$

Hence, the required fan power is:

$$W_{fan} = \frac{\dot{Q}_{air} \cdot FTP}{\eta_{fan}} = \frac{1.0 \times 41.24}{0.7} = 58.91 \text{ W} \quad (\text{Ans.})$$

The required mass of the rectangular duct is given by:

$$m_{rectangular} = 2(a+b) \times (\text{thickness}) \times (\text{density}) = 8.94 \text{ kg} \quad (\text{Ans.})$$

Thus for the same flow rate and velocity, a **rectangular duct consumes 54.5% higher fan power** and **weighs 41%** compared to a circular duct.

9. Air at a flow rate of 1.2 kg/s flows through a fitting with sudden enlargement. The area before and after the enlargements are 0.1 m<sup>2</sup> and 1 m<sup>2</sup>, respectively. Find the pressure drop due to sudden enlargement using Borda-Carnot Equation. What is the pressure drop if the same amount of air flows through a sudden contraction with area changing from 0.1 m<sup>2</sup> and 1 m<sup>2</sup>.

**Ans.:** Assuming standard air conditions, the density of air is approximately equal to 1.2 kg/m<sup>3</sup>. Hence the volumetric flow rate of air, Q is given by:

$$Q = (\text{mass flow rate/density}) = (1.2/1.2) = 1.0 \text{ m}^3/\text{s}$$

Sudden enlargement:

From Borda-Carnot Equation; pressure drop due to sudden enlargement is given by:

$$\Delta p_{d, \text{enl}} = \left( \frac{\rho V_1^2}{2} \right) \left( 1 - \frac{A_1}{A_2} \right)^2$$

$$\text{Velocity } V_1 = Q/A_1 = 1.0/0.1 = 10 \text{ m/s and } A_1/A_2 = 0.1/1.0 = 0.1$$

Substituting the above values in the equation, we get:

$$\Delta p_{d, \text{enl}} = \left( \frac{\rho V_1^2}{2} \right) \left( 1 - \frac{A_1}{A_2} \right)^2 = \left( \frac{1.2 \times 10^2}{2} \right) (1 - 0.1)^2 = 48.6 \text{ N/m}^2 \quad (\text{Ans.})$$

Sudden contraction:

Pressure drop due to sudden contraction is given by Borda-Carnot equation:

$$\Delta p_{d, \text{con}} = \left( \frac{\rho V_2^2}{2} \right) \left( \frac{A_2}{A_1} - 1 \right)^2 = \left( \frac{\rho V_2^2}{2} \right) \left( \frac{1}{C_c} - 1 \right)$$

From Table 37.3, for an area ratio ( $A_2/A_1$ ) of 0.1, the contraction coefficient  $C_c$  is **0.624**. The velocity after contraction ( $V_2$ ) is 10 m/s. Hence substituting these values in the above equation:

$$\Delta p_{d, \text{con}} = \left( \frac{\rho V_2^2}{2} \right) \left( \frac{1}{C_c} - 1 \right) = \left( \frac{1.2 \times 10^2}{2} \right) \left( \frac{1.0}{0.624} - 1 \right) = 36.15 \text{ N/m}^2 \quad (\text{Ans.})$$

It can be seen from the example that for the same area ratio and flow rate, the pressure drop due to sudden enlargement is larger than that due to sudden contraction by about **34.4%**.

**10.** Air at a flow rate of  $1 \text{ m}^3/\text{s}$  flows through a fitting whose cross-sectional area increases gradually from  $0.08 \text{ m}^2$  to  $0.12 \text{ m}^2$ . If the static regain factor (**R**) of the fitting is 0.8, what is the rise in static pressure (static regain) and total pressure loss as air flows through the fitting?

**Ans.:** The velocity of air at the inlet and exit of the fitting are:

$$V_{\text{in}} = 1/A_{\text{in}} = 1/0.08 = 12.5 \text{ m/s and } V_{\text{out}} = 1/A_{\text{out}} = 1/0.12 = 8.33 \text{ m/s}$$

Taking a value of  $1.2 \text{ kg/m}^3$  for the density of air, the velocity pressure at the inlet and exit are given by:

$$P_{v,\text{in}} = (\rho V_{\text{in}}^2)/2 = (1.2 \times 12.5^2)/2 = 93.75 \text{ N/m}^2$$

$$P_{v,\text{out}} = (\rho V_{\text{out}}^2)/2 = (1.2 \times 8.33^2)/2 = 41.63 \text{ N/m}^2$$

Static pressure rise through the fitting (static regain) is given by:

$$(P_{s,\text{out}} - P_{s,\text{in}}) = R(P_{v,\text{in}} - P_{v,\text{out}}) = 0.8 \times (93.75 - 41.63) = 36.484 \text{ N/m}^2 \quad \text{(Ans.)}$$

The loss in total pressure is given by:

$$\Delta P_{t,\text{loss}} = (1-R) (P_{v,\text{in}} - P_{v,\text{out}}) = 0.2 \times (93.75 - 41.63) = 15.636 \text{ N/m}^2 \quad \text{(Ans.)}$$

# Lesson

## 38

# Design Of Air Conditioning Ducts



## The specific objectives of this chapter are to:

1. Important requirements of an air conditioning duct (*Section 38.1*)
2. General rules for duct design (*Section 38.2*)
3. Classification of duct systems (*Section 38.3*)
4. Commonly used duct design methods (*Section 38.4*)
5. Principle of velocity method (*Section 38.4.1*)
6. Principle of equal friction method (*Section 38.4.2*)
7. Principle of static regain method (*Section 38.4.3*)
8. Performance of duct systems (*Section 38.5*)
9. System balancing and optimization (*Section 38.6*)
10. Introduction to fans and fan laws (*Section 38.7*)
11. Interaction between fan and duct system (*Section 38.8*)

At the end of the chapter, the student should be able to:

1. State the important requirements of an air conditioning duct and the general rules to be followed in the design of ducts
2. Classify air conditioning ducts based on air velocity and static pressure
3. Design air conditioning ducts using velocity method, equal friction method or static regain method
4. Explain typical performance characteristics of a duct system
5. Explain the importance of system balancing and optimization
6. State and explain the importance of fan laws, and use the performance of fans under off-design conditions
7. Describe interaction between fan and duct and the concept of balance point

### 38.1. Introduction:

The chief requirements of an air conditioning duct system are:

1. It should convey specified rates of air flow to prescribed locations
2. It should be economical in combined initial cost, fan operating cost and cost of building space
3. It should not transmit or generate objectionable noise

Generally at the time of designing an air conditioning duct system, the required airflow rates are known from load calculations. The location of fans and air outlets are fixed initially. The duct layout is then made taking into account the space available and ease of construction. In principle, required amount of air can be conveyed through the air conditioning ducts by a number of combinations. However, for a given system, only one set results in the optimum design. Hence, it is essential to identify the relevant design parameters and then optimize the design.

### 38.2. General rules for duct design:

1. Air should be conveyed as directly as possible to save space, power and material
2. Sudden changes in directions should be avoided. When not possible to avoid sudden changes, turning vanes should be used to reduce pressure loss
3. Diverging sections should be gradual. Angle of divergence  $\leq 20^\circ$
4. Aspect ratio should be as close to 1.0 as possible. Normally, it should not exceed 4
5. Air velocities should be within permissible limits to reduce noise and vibration
6. Duct material should be as smooth as possible to reduce frictional losses

### 38.3. Classification of duct systems:

Ducts are classified based on the load on duct due to air pressure and turbulence. The classification varies from application to application, such as for residences, commercial systems, industrial systems etc. For example, one such classification is given below:

Low pressure systems: Velocity  $\leq 10$  m/s, static pressure  $\leq 5$  cm H<sub>2</sub>O (g)

Medium pressure systems: Velocity  $\leq 10$  m/s, static pressure  $\leq 15$  cm H<sub>2</sub>O (g)

High pressure systems: Velocity  $> 10$  m/s, static pressure  $15 < p_s \leq 25$  cm H<sub>2</sub>O (g)

High velocities in the ducts results in:

1. Smaller ducts and hence, lower initial cost and lower space requirement
2. Higher pressure drop and hence larger fan power consumption
3. Increased noise and hence a need for noise attenuation

Recommended air velocities depend mainly on the application and the noise criteria. Typical recommended velocities are:

**Residences:** 3 m/s to 5 m/s

**Theatres:** 4 to 6.5 m/s

**Restaurants:** 7.5 m/s to 10 m/s

If nothing is specified, then a velocity of **5 to 8 m/s** is used for main ducts and a velocity of **4 to 6 m/s** is used for the branches. The allowable air velocities can be as high as 30 m/s in ships and aircrafts to reduce the space requirement.

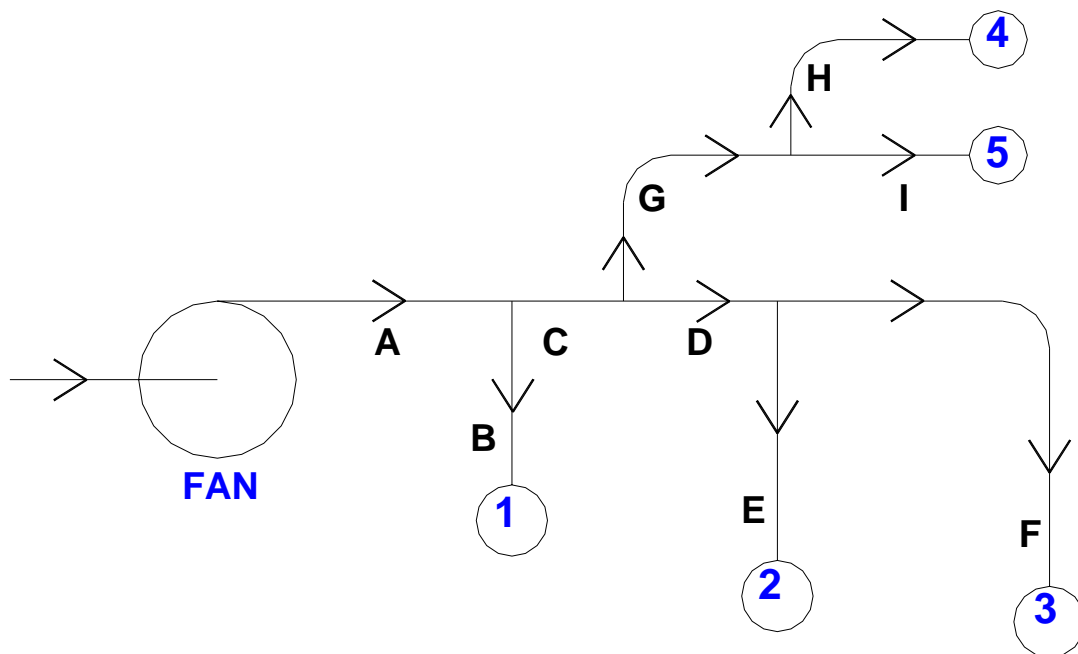
### 38.4. Commonly used duct design methods:

Figure 38.1 shows the schematic of a typical supply air duct layout. As shown in the figure, supply air from the fan is distributed to five outlets (1 to 5), which are located in five different conditioned zones. The letters A to I denote the portions of the duct to different outlets. Thus A-B is the duct running from the supply air fan to zone 1, A-B-C is the duct running from supply fan to conditioned zone and so on. These are known as duct runs. The run with the highest pressure drop is called as the **index run**. From load and psychrometric calculations the required supply airflow rates to each conditioned space are known. From the building layout and the location of the supply fan, the length of each duct run is known. The purpose of the duct design is to select suitable

dimensions of duct for each run and then to select a fan, which can provide the required supply airflow rate to each conditioned zone.

Due to the several issues involved, the design of an air conditioning duct system in large buildings could be a sophisticated operation requiring the use of Computer Aided Design (CAD) software. However, the following methods are most commonly used for simpler lay-outs such as the one shown in Fig.38.1.

1. Velocity method
2. Equal Friction Method
3. Static Regain method



**Fig.38.1:** Typical air conditioning duct lay-out

#### **38.4.1. Velocity method:**

The various steps involved in this method are:

- i. Select suitable velocities in the main and branch ducts
- ii. Find the diameters of main and branch ducts from airflow rates and velocities for circular ducts. For rectangular ducts, find the cross-sectional area from flow rate and velocity, and then by fixing the aspect ratio, find the two sides of the rectangular duct
- iii. From the velocities and duct dimensions obtained in the previous step, find the frictional pressure drop for main and branch ducts using friction chart or equation.

iv. From the duct layout, dimensions and airflow rates, find the dynamic pressure losses for all the bends and fittings

v. Select a fan that can provide sufficient FTP for the index run

vi. Balancing dampers have to be installed in each run. The damper in the index run is left completely open, while the other dampers are throttled to reduce the flow rate to the required design values.

The velocity method is one of the simplest ways of designing the duct system for both supply and return air. However, the application of this method requires selection of suitable velocities in different duct runs, which requires experience. Wrong selection of velocities can lead to very large ducts, which, occupy large building space and increases the cost, or very small ducts which lead to large pressure drop and hence necessitates the selection of a large fan leading to higher fan cost and running cost. In addition, the method is not very efficient as it requires partial closing of all the dampers except the one in the index run, so that the total pressure drop in each run will be same.

**For example,** let the duct run A-C-G-H be the index run and the total pressure drop in the index run is 100 Pa. If the pressure drop in the shortest duct run (say A-B) is 10 Pa, then the damper in this run has to be closed to provide an additional pressure drop of 90 Pa, so that the required airflow rate to the conditioned zone 1 can be maintained. Similarly the dampers in the other duct runs also have to be closed partially, so that the total pressure drop with damper partially closed in each run will be equal to the pressure drop in the index run with its damper left open fully.

#### 38.4.2. Equal friction method:

In this method the frictional pressure drop per unit length in the main and branch ducts ( $\Delta p_f/L$ ) are kept same, i.e.,

$$\left(\frac{\Delta p_f}{L}\right)_A = \left(\frac{\Delta p_f}{L}\right)_B = \left(\frac{\Delta p_f}{L}\right)_C = \left(\frac{\Delta p_f}{L}\right)_D = \dots \quad (38.1)$$

Then the stepwise procedure for designing the duct system is as follows:

i. Select a suitable frictional pressure drop per unit length ( $\Delta p_f/L$ ) so that the combined initial and running costs are minimized.

ii. Then the equivalent diameter of the main duct (A) is obtained from the selected value of ( $\Delta p_f/L$ ) and the airflow rate. As shown in Fig.38.1, airflow rate in

the main duct  $\dot{Q}_A$  is equal to the sum total of airflow rates to all the conditioned zones, i.e.,

$$\dot{Q}_A = \dot{Q}_1 + \dot{Q}_2 + \dot{Q}_3 + \dot{Q}_4 + \dot{Q}_5 = \sum_{i=1}^N \dot{Q}_i \quad (38.2)$$

From the airflow rate and  $(\Delta p_f/L)$  the equivalent diameter of the main duct ( $D_{eq,A}$ ) can be obtained either from the friction chart or using the frictional pressure drop equation, i.e.,

$$D_{eq,A} = \left( \frac{0.022243 \dot{Q}_A^{1.852}}{\left( \frac{\Delta p_f}{L} \right)_A} \right)^{\left( \frac{1}{4.973} \right)} \quad (38.3)$$

iii. Since the frictional pressure drop per unit length is same for all the duct runs, the equivalent diameters of the other duct runs, B to I are obtained from the equation:

$$\left( \frac{\dot{Q}^{1.852}}{D_{eq}^{4.973}} \right)_A = \left( \frac{\dot{Q}^{1.852}}{D_{eq}^{4.973}} \right)_B = \left( \frac{\dot{Q}^{1.852}}{D_{eq}^{4.973}} \right)_C = \dots \quad (38.4)$$

iv. If the ducts are rectangular, then the two sides of the rectangular duct of each run are obtained from the equivalent diameter of that run and by fixing aspect ratio as explained earlier. Thus the dimensions of the all the duct runs can be obtained. The velocity of air through each duct is obtained from the volumetric flow rate and the cross-sectional area.

v. Next from the dimensions of the ducts in each run, the total frictional pressure drop of that run is obtained by multiplying the frictional pressure drop per unit length and the length, i.e.,

$$\Delta P_{f,A} = \left( \frac{\Delta p_f}{L} \right)_A \cdot L_A ; \Delta P_{f,B} = \left( \frac{\Delta p_f}{L} \right)_B \cdot L_B \dots \quad (38.5)$$

vi. Next the dynamic pressure losses in each duct run are obtained based on the type of bends or fittings used in that run.

vii. Next the total pressure drop in each duct run is obtained by summing up the frictional and dynamic losses of that run, i.e.,

$$\Delta P_A = \Delta p_{f,A} + \Delta p_{d,A}; \Delta P_B = \Delta p_{f,B} + \Delta p_{d,B} \dots \quad (38.6)$$

viii. Next the fan is selected to suit the index run with the highest pressure loss. Dampers are installed in all the duct runs to balance the total pressure loss.

Equal friction method is simple and is most widely used conventional method. This method usually yields a better design than the velocity method as most of the available pressure drop is dissipated as friction in the duct runs, rather than in the balancing dampers. This method is generally suitable when the ducts are not too long, and it can be used for both supply and return ducts. However, similar to velocity method, the equal friction method also requires partial closure of dampers in all but the index run, which may generate noise. If the ducts are too long then the total pressure drop will be high and due to dampering, ducts near the fan get over-pressurized.

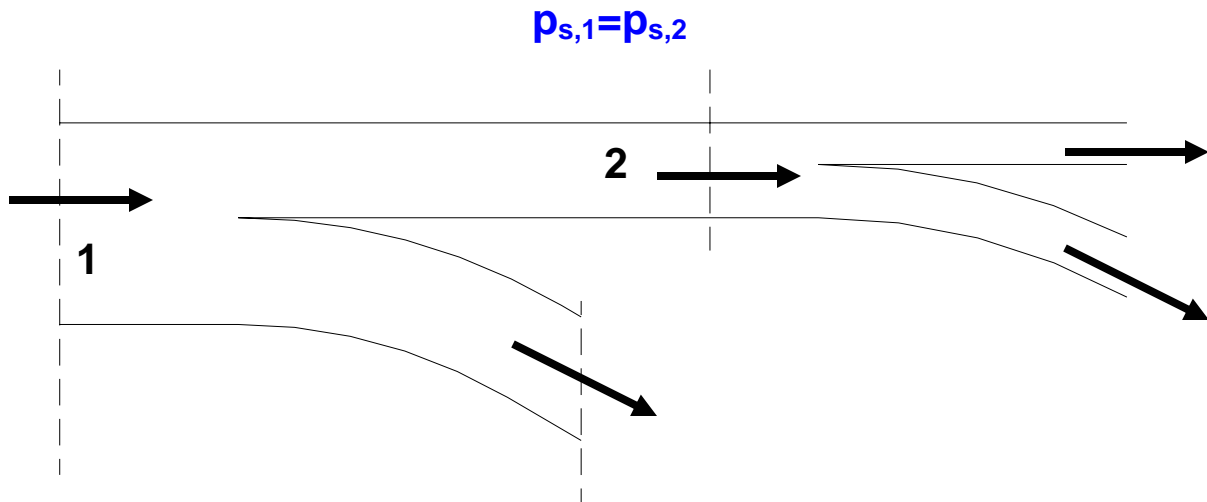
### 38.4.3. Static Regain Method:

This method is commonly used for high velocity systems with long duct runs, especially in large systems. In this method the static pressure is maintained same before each terminal or branch. The procedure followed is as given below:

- i. Velocity in the main duct leaving the fan is selected first.
- ii. Velocities in each successive runs are reduced such that the **gain in static pressure due to reduction in velocity pressure equals the frictional pressure drop in the next duct section**. Thus the static pressure before each terminal or branch is maintained constant. For example, Fig.38.2 shows a part of the duct run with two sections 1 and 2 before two branch take-offs. The velocity at 1 is greater than that at 2, such that the static pressure is same at 1 and 2. Then using the static regain factor, one can write:

$$\Delta p_{f,2} + \Delta p_{d,2} = R(p_{v,1} - p_{v,2}) \quad (38.7)$$

where  $\Delta p_{f,2}$  and  $\Delta p_{d,2}$  are the frictional and dynamic losses between 1 and 2, and  $p_{v,1}$  and  $p_{v,2}$  are the velocity pressures at 1 and 2 respectively.



**Fig.38.2:** Principle of static regain method

iii. If section 1 is the outlet of the fan, then its dimensions are known from the flow rate and velocity (initially selected), however, since both the dimensions and velocity at section 2 are not known, a trial-and-error method has to be followed to solve the above equation, which gives required dimensions of the section at 2.

iv. The procedure is followed in the direction of airflow, and the dimensions of the downstream ducts are obtained.

v. As before, the total pressure drop is obtained from the pressure drop in the longest run and a fan is accordingly selected.

Static Regain method yields a more balanced system and does not call for unnecessary dampering. However, as velocity reduces in the direction of airflow, the duct size may increase in the airflow direction. Also the velocity at the exit of the longer duct runs may become too small for proper air distribution in the conditioned space.



### 38.5. Performance of duct systems:

For the duct system with air in turbulent flow, the total pressure loss ( $\Delta p_t$ ) is proportional to the square of flow rate; i.e.,

$$\text{total pressure drop, } \Delta P_t \propto (\dot{Q})^2 \quad (38.8)$$

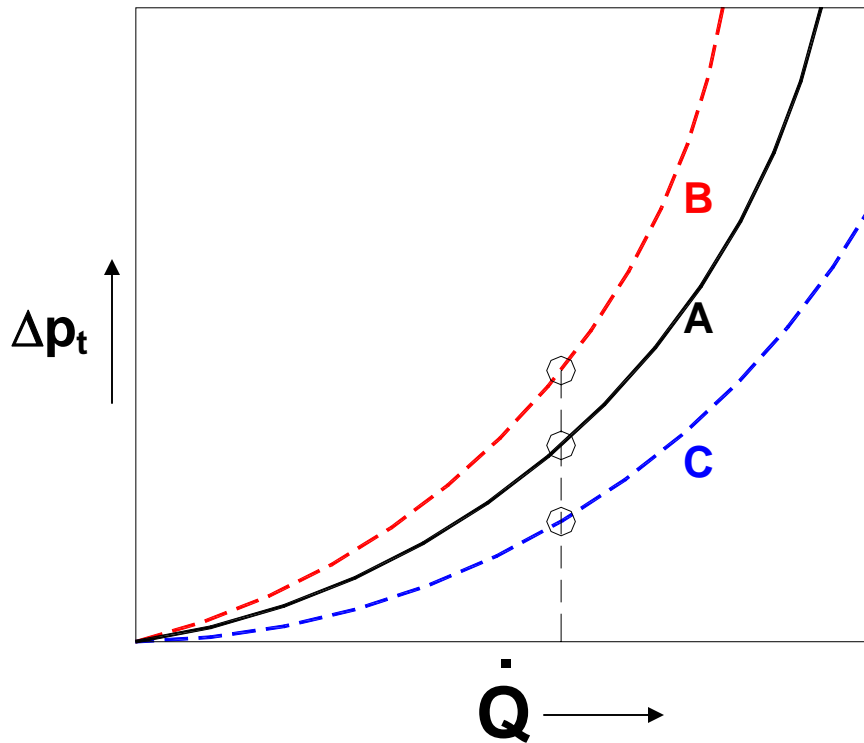
$$\text{or, total pressure drop, } \Delta P_t = C(\dot{Q})^2 \quad (38.9)$$

where C is the resistance offered by the duct system. Once the duct system is designed and installed, the value of C is supposed to remain constant. However, if the air filters installed in the duct become dirty and/or if the damper position is altered, then the value of C changes. Thus variation of total pressure drop with airflow rate is parabolic in nature as shown in Fig. 38.3. In this figure, the curve A refers to the performance of the duct at design conditions, while curve B refers to the performance under the conditions of a dirty filter and/or a higher damper closure and curve C refers to the performance when the damper is opened more.

From the duct characteristic curve for constant resistance, one can write

$$\frac{\Delta p_{t,1}}{\Delta p_{t,2}} = \frac{(\dot{Q}_1)^2}{(\dot{Q}_2)^2} \quad (38.10)$$

Thus knowing the total pressure drop and airflow rate at design condition (say 1), one can obtain the total pressure drop at an off-design condition 2, using the above equation.



**Fig.38.3:** Variation of total pressure drop with flow rate for a given duct system

### 38.6. System balancing and optimization:

In large buildings, after the Air Handling Unit is installed, it has to be balanced for satisfactory performance. System balancing requires as a first step, measurements of actual airflow rates at all supply air outlets and return air inlets. Then the dampers are adjusted so that the actual measured flow rate corresponds to the specified flow rates. System balancing may also require adjusting the fan speed to get required temperature drop across the cooling or heating coils and required airflow rates in the conditioned zone. Balancing a large air conditioning system can be a very expensive and time consuming method and may require very accurate instruments for measuring air flow rates and temperatures. However, system balancing is always recommended to get the full benefit from the total cost incurred on air conditioning system.

Large air conditioning systems require optimization of the duct design so as to minimize the total cost, which includes the initial cost of the system and the lifetime operating cost. At present very sophisticated commercial computer software are available for optimizing the duct design. One such method is called as T-Method. The reader should refer to advanced textbooks or ASHRAE handbooks for details on duct optimization methods.

## 38.7. Fans:

The fan is an essential and one of the most important components of almost all air conditioning systems. Thus a basic understanding of fan performance characteristics is essential in the design of air conditioning systems. The centrifugal fan is most commonly used in air conditioning systems as it can efficiently move large quantities of air over a large range of pressures. The operating principle of a centrifugal fan is similar to that of a centrifugal compressor discussed earlier. The **centrifugal fan with forward-curved blades** is widely used in low-pressure air conditioning systems. The more efficient **backward-curved and airfoil type** fans are used in large capacity, high-pressure systems.

### 38.7.1. Fan laws:

The fan laws are a group of relations that are used to predict the effect of change of operating parameters of the fan on its performance. **The fan laws are valid for fans, which are geometrically and dynamically similar.** The fan laws have great practical use, as it is not economically feasible to test fans of all sizes under all possible conditions.

The important operating parameters of a fan of **fixed diameter** are:

1. Density of air ( $\rho$ ) which depends on its temperature and pressure
2. Operating speed of the fan ( $\omega$  in rps), and
3. Size of the fan.

Here the fan laws related to the density of air and the rotative speed of the fan are considered. The effect of the size of the fan is important at the time of designing the fan. For a given air conditioning system with fixed dimensions, fittings etc. it can be easily shown that:

$$\text{airflow rate, } \dot{Q} \propto \omega \quad (38.11)$$

$$\text{static pressure rise, } \Delta p_s \propto \frac{\rho V^2}{2} \quad (38.12)$$

$$\text{fan power input, } \dot{W} \propto \dot{Q}(\Delta p_s) + \dot{Q} \left( \frac{\rho V^2}{2} \right) \quad (38.13)$$

From the expression for fan power input (Eqn.(38.13)), it can be seen that the 1<sup>st</sup> term on the RHS accounts for power input required for increasing the static pressure of air and the 2<sup>nd</sup> term on RHS accounts for the power input required to impart kinetic energy to air as it flows through the fan. Using the above relations, the following fan laws can be obtained.

**Law 1:** Density of air  $\rho$  remains constant and the speed  $\omega$  varies:

$$\dot{Q} \propto \omega; \Delta p_s \propto \omega^2 \text{ and } \dot{W} \propto \omega^3 \quad (38.14)$$

**Law 2:** Airflow rate  $\dot{Q}$  remains constant and the density  $\rho$  varies:

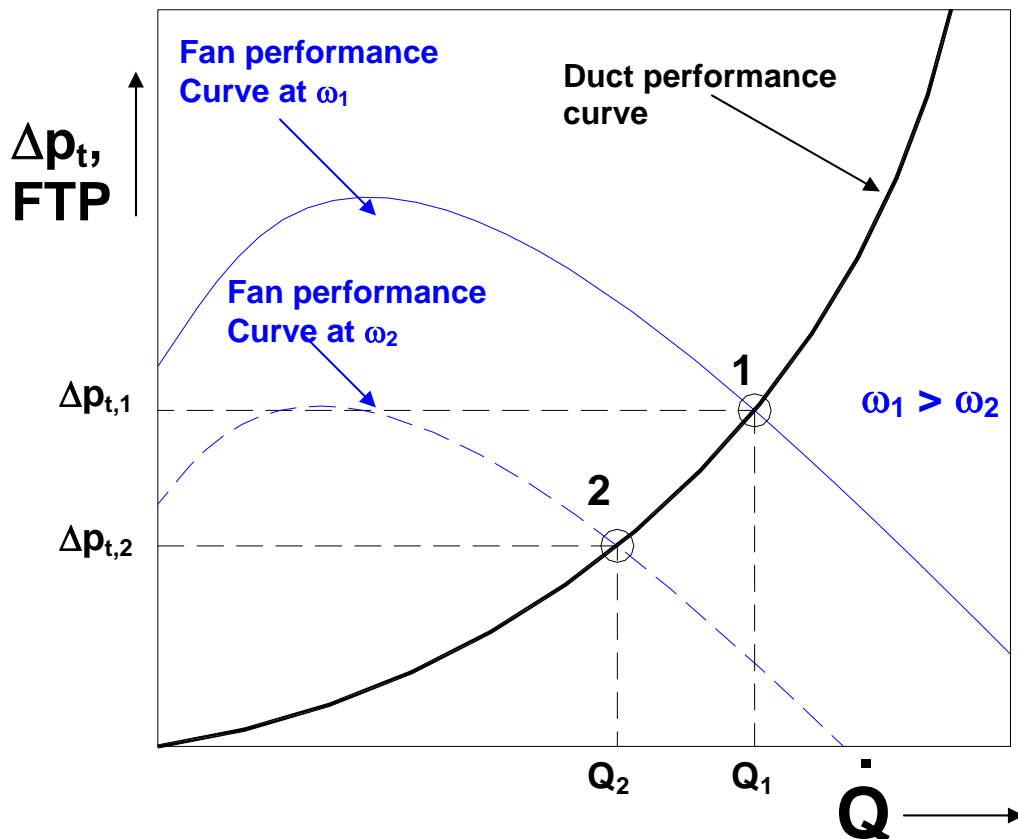
$$\dot{Q} = \text{constant}; \Delta p_s \propto \rho \text{ and } \dot{W} \propto \rho \quad (38.15)$$

**Law 3:** Static pressure rise  $\Delta p_s$  remains constant and density  $\rho$  varies:

$$\dot{Q} \propto \frac{1}{\sqrt{\rho}}; \Delta p_s = \text{constant}, \omega \propto \frac{1}{\sqrt{\rho}} \text{ and } \dot{W} \propto \frac{1}{\sqrt{\rho}} \quad (38.16)$$

### 38.8. Interaction between fan and duct system:

Figure 38.4 shows the variation of FTP of a centrifugal fan (**fan performance curve**) and variation of total pressure loss of a duct system (**duct performance curve**) as functions of the airflow rate. As shown in the figure, the point of intersection of the fan performance curve and the duct performance curve yield the **balance point** for the combined performance of fan and duct system. Point 1 gives a balance point between the fan and duct system when the rotative speed of fan is  $\omega_1$ . At this condition the airflow rate is  $Q_1$  and the total



**Fig.38.4:** Fan and duct performance curves and balance points

pressure loss which is equal to the FTP is  $\Delta p_{t,1}$ . Now if the flow rate is reduced to  $Q_2$ , then the total pressure loss reduces to  $\Delta p_{t,2}$ . To match the reduced flow rate and the reduced pressure loss, the speed of the fan has to be reduced to  $\omega_2$  or the position of the inlet guide vanes of the centrifugal fan have to be adjusted to reduce the flow rate. This will give rise to a new balance point at 2. Thus the fan and duct system have to be matched when there is a change in the operating conditions.

### Questions and answers:

1. State which of the following statements are TRUE?

- a) The air conditioning duct should have high aspect ratio for good performance
- b) If the air conditioning duct is diverging, then the angle of divergence should be as small as possible to reduce pressure loss
- c) To minimize noise and vibration, air should flow with a low velocity
- d) All of the above

**Ans.: b) and c)**

2. State which of the following statements are TRUE?

- a) High air velocity in ducts results in lower initial costs but higher operating costs
- b) Higher air velocities may result in acoustic problems
- c) Air velocities as high as 30 m/s are used in residential systems
- d) Low air velocities are recommended for recording studios

**Ans.: a), b) and d)**

3. State which of the following statements are TRUE?

- a) In a duct layout, the total pressure drop is maximum in the index run
- b) At balanced condition, the total pressure drop is equal for all duct runs
- c) Dampers are required for balancing the flow in each duct run
- d) All of the above

**Ans.: d)**

4. State which of the following statements are TRUE?

- a) If not done properly, the velocity method gives rise to large sized ducts
- b) In equal friction method, dampering is not required
- c) In static regain method, dampering is required
- d) All of the above

**Ans.: c)**

5. State which of the following statements are TRUE?

- a) In a given duct system, the total pressure drop varies linearly with flow rate
- b) In a given duct system, the total pressure drop varies in a parabolic manner with flow rate
- c) For a given flow rate, the total pressure drop of a duct increases as the dampers are opened more
- d) For a given flow rate, the total pressure drop of a duct is less when the air filters are new

**Ans.: b) and d)**

6. State which of the following statements are TRUE?

- a) Compared to forward curved blades, backward curved blades are more efficient
- b) Airfoil type blades are used in small capacity systems
- c) Fan laws are applicable to all types of fans
- d) Fan laws are applicable to fans that are geometrically and dynamically similar

**Ans.: a) and d)**

7. State which of the following statements are TRUE?

- a) For a given fan operating at a constant temperature, the power input to fan increases by 4 times when the fan speed becomes double
- b) For a given fan operating at a constant temperature, the power input to fan increases by 8 times when the fan speed becomes double
- c) For a given fan operating at a constant flow rate, the power input increases as the air temperature increases
- d) For a given fan operating at a constant static pressure rise, the flow rate reduces as the air temperature increases

**Ans.: b)**

8. State which of the following statements are TRUE?

- a) For a backward curved blade, the fan total pressure (FTP) increases as flow rate increases
- b) For a backward curved blade, the fan total pressure (FTP) reaches a maximum at a particular flow rate
- c) When the air filter in the air conditioning duct becomes dirty, the speed has to be increased to maintain the balance between fan and duct systems
- d) When the damper installed in the duct is opened more, to maintain the balance, the speed of the fan should be increased

**Ans.: b) and c)**

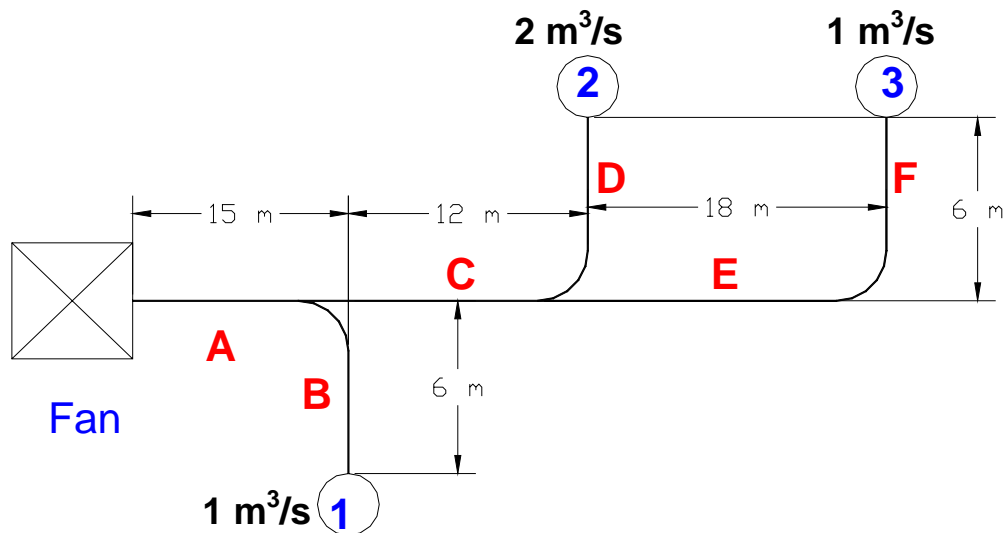
9. Find the dimensions of a rectangular duct of aspect ratio (1:2) when  $0.2 \text{ m}^3/\text{s}$  of air flows through it. The allowable frictional pressure drop is  $3 \text{ Pa/m}$ .

**Ans:** For a flow rate of  $0.2 \text{ m}^3/\text{s}$  and an allowable frictional pressure drop of  $3 \text{ Pa/m}$ , the equivalent diameter is found to be  $0.2 \text{ m}$  from friction chart or friction equation.

Then taking an **aspect ratio of 1:2**, the dimensions of the rectangular duct are found to be :

$$a \approx 0.13 \text{ m and } b \approx 0.26 \text{ m.} \quad (\text{Ans.})$$

10. The following figure shows a typical duct layout. Design the duct system using a) Velocity method, and b) Equal friction method. Take the velocity of air in



the main duct (A) as  $8 \text{ m/s}$  for both the methods. Assume a dynamic loss coefficient of  $0.3$  for upstream to downstream and  $0.8$  for upstream to branch and for the elbow. The dynamic loss coefficients for the outlets may be taken as  $1.0$ . Find the FTP required for each case and the amount of dampering required.

**Ans.:**

**a) Velocity method:** Select a velocity of  $5 \text{ m/s}$  for the downstream and branches. Then the dimensions of various duct runs are obtained as shown below:

Segment A: Flow rate,  $Q_A = 4 \text{ m}^3/\text{s}$  and velocity,  $V_A = 8 \text{ m/s}$

$$\Rightarrow \text{cross-sectional area } A_A = Q_A/V_A = 4/8 = 0.5 \text{ m}^2 \Rightarrow D_{\text{eq,A}} = 0.798 \text{ m} \quad (\text{Ans.})$$

Segment B: Flow rate,  $Q_B = 1 \text{ m}^3/\text{s}$  and velocity,  $V_B = 5 \text{ m/s}$

⇒ cross-sectional area  $A_B = Q_B/V_B = 1/5 = 0.2 \text{ m}^2 \Rightarrow D_{\text{eq},B} = \mathbf{0.505 \text{ m}}$  (Ans.)

Segment C: Flow rate,  $Q_C = 3 \text{ m}^3/\text{s}$  and velocity,  $V_C = 5 \text{ m/s}$

⇒ cross-sectional area  $A_C = Q_C/V_C = 3/5 = 0.6 \text{ m}^2 \Rightarrow D_{\text{eq},A} = \mathbf{0.874 \text{ m}}$  (Ans.)

Segment D: Flow rate,  $Q_D = 2 \text{ m}^3/\text{s}$  and velocity,  $V_D = 5 \text{ m/s}$

⇒ cross-sectional area  $A_D = Q_D/V_D = 2/5 = 0.4 \text{ m}^2 \Rightarrow D_{\text{eq},D} = \mathbf{0.714 \text{ m}}$  (Ans.)

Segments E&F: Flow rate,  $Q_{E,F} = 1 \text{ m}^3/\text{s}$  and velocity,  $V_{E,F} = 5 \text{ m/s}$

⇒ cross-sectional area  $A_{E,F} = Q_{E,F}/V_{E,F} = 1/5 = 0.2 \text{ m}^2 \Rightarrow D_{\text{eq},A} = \mathbf{0.505 \text{ m}}$  (Ans.)

Calculation of pressure drop:

Section A-B:

$$\Delta P_{A-B} = \Delta P_{A,f} + \Delta P_{b,f} + \Delta P_{u-b} + \Delta P_{\text{exit}}$$

where  $\Delta P_{A,f}$  and  $\Delta P_{B,f}$  stand for frictional pressure drops in sections A and B, respectively,  $\Delta P_{u-b}$  is the dynamic pressure drop from upstream to branch and  $\Delta P_{\text{exit}}$  is the dynamic pressure loss at the exit 1.

The frictional pressure drop is calculated using the equation:

$$\Delta p_{A,f} = \frac{0.022243 \dot{Q}_{\text{air}}^{1.852} L}{D^{4.973}} = \frac{0.022243 \times 4^{1.852} \times 15}{0.798^{4.973}} = 13.35 \text{ Pa}$$

$$\Delta p_{B,f} = \frac{0.022243 \dot{Q}_{\text{air}}^{1.852} L}{D^{4.973}} = \frac{0.022243 \times 1^{1.852} \times 6}{0.505^{4.973}} = 3.99 \text{ Pa}$$

The dynamic pressure drop from upstream to branch is given by:

$$\Delta p_{u-b} = C_{u-b} \left( \frac{\rho V_d^2}{2} \right) = 0.8 \left( \frac{1.2 \times 5^2}{2} \right) = 12 \text{ Pa}$$

The dynamic pressure drop at the exit is given by:

$$\Delta p_{\text{exit},1} = C_{\text{exit}} \left( \frac{\rho V_1^2}{2} \right) = 1.0 \left( \frac{1.2 \times 5^2}{2} \right) = 15 \text{ Pa}$$



Hence total pressure drop from the fan to the exit of 1 is given by:

$$\Delta P_{A-B} = \Delta P_{A,f} + \Delta P_{b,f} + \Delta P_{u-b} + \Delta P_{\text{exit}} = 13.35 + 3.99 + 12 + 15 = 44.34 \text{ Pa}$$

In a similar manner, the pressure drop from fan to 2 is obtained as:

$$\Delta P_{A-C-D} = \Delta P_{A,f} + \Delta P_{C,f} + \Delta P_{D,f} + \Delta P_{u-b} + \Delta P_{u-d} + \Delta P_{\text{exit}}$$

$$\Delta P_{A-C-D} = 13.35 + 3.99 + 2.57 + 12 + 4.5 + 15 = 51.41 \text{ Pa}$$

Pressure drop from fan to exit 3 is obtained as:

$$\Delta P_{A-C-E-F} = \Delta P_{A,f} + \Delta P_{C,f} + \Delta P_{E,f} + \Delta P_{F,f} + \Delta P_{u-d,C} + \Delta P_{u-d,E} + \Delta P_{\text{elbow}} + \Delta P_{\text{exit}}$$

$$\Delta P_{A-C-E-F} = 13.35 + 3.99 + 11.97 + 3.99 + 4.5 + 4.5 + 12 + 15 = 69.3 \text{ Pa}$$

Thus the run with maximum pressure drop is A-C-E-F is the index run. Hence the FTP required is:

$$\text{FTP} = \Delta P_{A-C-E-F} = 69.3 \text{ Pa} \quad (\text{Ans.})$$

$$\text{Amount of dampering required at 1} = \text{FTP} - \Delta P_{A-B} = 24.96 \text{ Pa} \quad (\text{Ans.})$$

$$\text{Amount of dampering required at 2} = \text{FTP} - \Delta P_{A-C-D} = 17.89 \text{ Pa} \quad (\text{Ans.})$$

### b) Equal Friction Method:

The frictional pressure drop in segment A is given by:

$$\frac{\Delta p_{f,A}}{L_A} = \frac{0.022243 \dot{Q}_{\text{air}}^{1.852}}{D^{4.973}} = \frac{0.022243 \times 4^{1.852}}{0.798^{4.973}} = 0.89 \text{ (Pa/m)}$$

The frictional pressure drops of B, C, D, E and F should be same as 0.89 Pa/m for Equal Friction Method. Hence, as discussed before:

$$\left( \frac{\dot{Q}^{1.852}}{D_{\text{eq}}^{4.973}} \right)_A = \left( \frac{\dot{Q}^{1.852}}{D_{\text{eq}}^{4.973}} \right)_B = \left( \frac{\dot{Q}^{1.852}}{D_{\text{eq}}^{4.973}} \right)_C = \dots$$

From the above equation, we obtain:

$$D_{eq,B} = D_{eq,A} \left( \frac{Q_B}{Q_A} \right)^{\left( \frac{1.852}{4.973} \right)} = 0.4762 \text{ m}$$

$$D_{eq,C} = D_{eq,A} \left( \frac{Q_C}{Q_A} \right)^{\left( \frac{1.852}{4.973} \right)} = 0.717 \text{ m}$$

$$D_{eq,D} = D_{eq,A} \left( \frac{Q_D}{Q_A} \right)^{\left( \frac{1.852}{4.973} \right)} = 0.6164 \text{ m}$$

$$D_{eq,E} = D_{eq,F} = D_{eq,A} \left( \frac{Q_E}{Q_A} \right)^{\left( \frac{1.852}{4.973} \right)} = 0.4762 \text{ m}$$

Calculation of total pressure drop:

From fan to 1:

$$\Delta P_{A-B} = \Delta P_{A,f} + \Delta P_{B,f} + \Delta P_{u-b} + \Delta P_{exit}$$

$$\Delta P_{A-B} = 13.35 + 5.34 + 15.1 + 18.9 = 52.69 \text{ Pa}$$

From fan to 2:

$$\Delta P_{A-C-D} = \Delta P_{A,f} + \Delta P_{C,f} + \Delta P_{D,f} + \Delta P_{u-d,C} + \Delta P_{u-b} + \Delta P_{exit}$$

$$\Delta P_{A-C-D} = 13.35 + 10.68 + 5.34 + 9.94 + 21.55 + 26.9 = 87.76 \text{ Pa}$$

From fan to exit 3:

$$\Delta P_{A-C-E-F} = \Delta P_{A,f} + \Delta P_{C,f} + \Delta P_{E,f} + \Delta P_{F,f} + \Delta P_{u-d,C} + \Delta P_{u-d,E} + \Delta P_{elbow} + \Delta P_{exit}$$

$$\Delta P_{A-C-E-F} = 13.35 + 10.68 + 16.02 + 5.34 + 9.94 + 5.67 + 15.1 + 18.9 = 95 \text{ Pa}$$

As before, the Index run is from fan to exit 3. The required FTP is:

$$\text{FTP} = \Delta P_{A-C-E-F} = 95 \text{ Pa} \quad (\text{Ans.})$$

$$\text{Amount of dampering required at 1} = \text{FTP} - \Delta P_{A-B} = 42.31 \text{ Pa} \quad (\text{Ans.})$$

$$\text{Amount of dampering required at 2} = \text{FTP} - \Delta P_{A-C-D} = 7.24 \text{ Pa} \quad (\text{Ans.})$$

From the example, it is seen that the Velocity method results in larger duct diameters due to the velocities selected in branch and downstream. However, the required FTP is lower in case of velocity method due to larger ducts.

Equal Friction method results in smaller duct diameters, but larger FTP.

Compared to velocity method, the required dampering is more at outlet 1 and less at outlet 2 in case of equal friction method.

**11.** A fan is designed to operate at a rotative speed of 20 rps. At the design conditions the airflow rate is 20 m<sup>3</sup>/s, the static pressure rise is 30 Pa and the air temperature is 20°C. At these conditions the fan requires a power input of 1.5 kW. Keeping the speed constant at 20 rps, if the air temperature changes to 10°C, what will be the airflow rate, static pressure and power input?

**Ans:** At design condition 1, Rotative speed,  $\omega_1$  = 20 rps  
Air temperature,  $T_1$  = 20°C = 293 K  
Airflow rate,  $Q_1$  = 20 m<sup>3</sup>/s  
Static pressure rise,  $\Delta p_{s,1}$  = 30 Pa  
Power input,  $W_1$  = 1.5 kW

At off-design condition 2, the rotative speed is same as 1, but temperature changes to 10°C (283 K), which changes the density of air. To find the other variables, the fan law 2 has to be applied as density varies; i.e.,

i) Airflow rate  $Q_1 = Q_2 = 20 \text{ m}^3/\text{s}$

ii) Static pressure rise at 2,

$$\Delta p_{s,2} = \Delta p_{s,1}(\rho_2/\rho_1) = \Delta p_{s,1}(T_1/T_2) = 30(293/283) = \mathbf{31.06 \text{ Pa}} \quad \text{(Ans.)}$$

iii) Power input at 2,

$$W_2 = W_1(\rho_2/\rho_1) = W_1(T_1/T_2) = 1.5(293/283) = \mathbf{1.553 \text{ kW}} \quad \text{(Ans.)}$$

# Lesson

## 39

# Space Air Distribution

## The specific objectives of this chapter are to:

1. Requirements of a proper air distribution system, definition of Air Distribution Performance Index and Space Diffusion Effectiveness Factor (*Section 39.1*)
2. Design of air distribution systems, buoyancy effects and deflection of air jets (*Section 39.2*)
3. Behaviour of free-stream jets, definitions of drop, throw, spread and entrainment ratio (*Section 39.3*)
4. Behaviour of circular jets (*Section 39.4*)
5. Behaviour of rectangular jets (*Section 39.5*)
6. Characteristics of different types of air distribution devices, such as grilles, registers, ceiling diffusers, slotted diffusers etc. (*Section 39.6*)
7. Return air inlets (*Section 39.7*)
8. Airflow pattern inside conditioned spaces using different types of air distribution devices (*Section 39.8*)
9. Stratified mixing flow (*Section 39.9*)
10. Cold air distribution (*Section 39.10*)
11. Displacement flow (*Section 39.11*)
12. Spot cooling/heating (*Section 39.12*)
13. Selection criteria for supply air inlets (*Section 39.13*)

At the end of the chapter, the student should be able to:

1. Explain the importance of proper air distribution in conditioned space and define ADPI and SDEF
2. List the factors to be considered in the design of air distribution devices and explain buoyancy effects and deflection of air jets
3. Estimate throw, drop, spread and entrainment ratio of circular and rectangular, isothermal free jets
4. List different types of supply air outlet devices and their characteristics
5. Draw the airflow patterns for ceiling, sidewall and slotted diffusers
6. Explain stratified mixing flow, displacement flow, cold air distribution and spot cooling and heating
7. List the criteria for selection of supply air outlets.

### 39.1. Introduction

After the required amount of supply air is transmitted to the conditioned space, it is essential to distribute the air properly within the conditioned space. Thus it is important to design suitable air distribution system, which satisfies the following requirements:

- a) Create a proper combination of temperature, humidity and air motion in the occupied zone. The **occupied zone** is defined as all the space in the conditioned zone that is from the floor to a height of 1.8 m and about 30 cms from the walls. In the occupied zone, the maximum variation in temperature should be less than **1°C** and the air velocity should be in the range of **0.15 m/s to 0.36 m/s**.

b) To avoid draft in the occupied zone. Draft is defined as the localized feeling of cooling or warmth. Draft is measured above or below the controlled room condition of 24.4 °C and an air velocity of 0.15 m/s at the center of the room. The **effective draft temperature** (EDT) for comfort is given by:

$$\text{EDT} = (\text{DBT} - 24.4) - 0.1276(V - 0.15) \quad (39.1)$$

where DBT is the local dry bulb temperature (in °C) and V is the local velocity (m/s). For comfort, the EDT should be within **-1.7°C to +1.1°C** and the air velocity should be **less than 0.36 m/s**.

### 39.1.1. Air Distribution Performance Index (ADPI)

The ADPI is defined as the percentage of measurements taken at many locations in the occupied zone of space that meets EDT criteria of -1.7°C to +1.1°C, that is:

$$\text{ADPI} = \left( \frac{N_0}{N} \right) \times 100 \quad (39.2)$$

where N is the total number of locations at which observations have been made, and  $N_0$  is the number of locations at which the effective draft temperature is within **-1.7°C to +1.1°C**.

The objective of air distribution system design is to select and place the supply air diffusers in such a way that the ADPI approaches 100 percent. The ADPI provides a rational way of selecting air diffusers. Studies show that the value of ADPI depends very much on space cooling load per unit area. A large value of space cooling load per unit area tends to reduce the value of ADPI.

### 39.1.2. Space Diffusion Effectiveness Factor (SDEF)

The effectiveness of air distribution system is sometimes assessed using **Space Diffusion Effectiveness Factor** (SDEF). It is defined as:

$$\text{SDEF} = \frac{T_{\text{ex}} - T_s}{T_r - T_s} \quad (39.3)$$

where  $T_{\text{ex}}$  is the temperature of the exhaust air,  $T_s$  is the supply air temperature and  $T_r$  is the temperature of the room air (at the measuring point). A SDEF value of  $\leq 1$  implies that some amount of cold supply air has not mixed with the room air and is leaving the conditioned space as exhaust. The space air distribution is considered to be effective if  $\text{SDEF} \geq 1.0$ .

Table 39.1 shows the recommended supply air velocities for diffusers. Since the air velocity at the supply air outlet is normally much higher than 0.36 m/s and its temperature is much lower than 24.4°C, it has to mix properly with the room air before it reaches the occupancy level. This depends on the effective design of the air distribution system.

Criterion	Application	Supply velocity, m/s
Noise	Studios, operating theatres	3 to 3.5
	Apartments, office spaces	4.0 to 5.0
	Restaurants, libraries	5.0 to 6.0
	Supermarkets	6.0 to 7.5
	Factories, Gymnasium	7.5

**Table 39.1:** Recommended air velocities for supply air diffusers

## 39.2. Design of air distribution systems

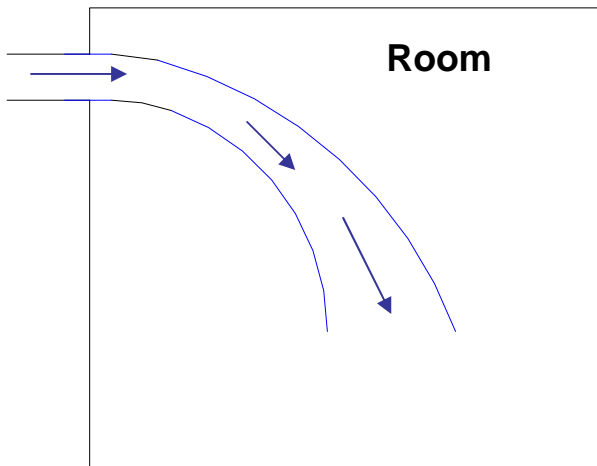
The objective of air distribution system design is to choose the location and type of supply air diffuser and the location and type of the return air grilles. The parameters that affect air velocity and temperature at a given point in the conditioned space are:

- a) Velocity of air at the inlet to the supply diffuser: Noise criteria to be observed
- b) Supply to room temperature difference ( $T_s - T_r$ )
- c) Geometry and Position of air supply outlet
- d) Position of return air inlet
- e) Room Geometry
- f) Room surface temperature: Lower the surface temperature (e.g. with glass) stronger are the natural convection currents.
- g) Internal heat sources (e.g. people, appliances)
- h) Room turbulence

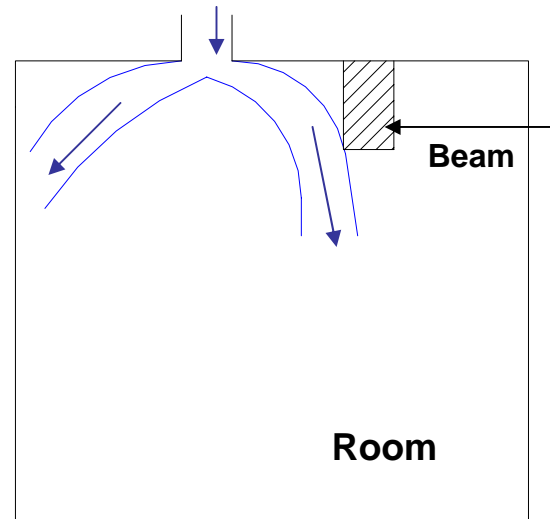
The exact prediction of velocity and temperature profiles inside the conditioned space requires simultaneous solution of mass, momentum and energy equations for the conditioned space. However in general this task is extremely complicated due to the several factors that affect airflow and heat transfer inside the conditioned space. However, a basic understanding of room air distribution requires the understanding of, buoyancy effects, deflection of air streams and behaviour of free-stream jets. Normally the location and type of return air grilles do not affect the air distribution significantly.

### 39.2.1. Buoyancy effects:

Due to the buoyancy effects, a supply air stream that is cooler than the room air will drop and supply air that is warmer than room air rises. However, from thermal comfort point-of-view, it is important that the supply air stream does not strike at occupancy level. Figure 39.1(a) shows the drop of a supply air jet that is cooler than the room air.



**Fig.39.1(a):** Drop of a cool air jet



**Fig.39.1(b):** Deflection of a cool air jet

It is understood that the buoyancy effects are due to temperature difference prevailing between the supply air and the room air. It can be shown that the velocity of an element at a height 'h' due to buoyancy is given by:

$$v_t^2 = gh \left( \frac{\Delta T}{T_r} \right) \quad (39.4)$$

where  $\Delta T$  is the difference between the local temperature of the fluid ( $T_f$ ) element and the room air ( $T_r$ ),  $T_r$  is the room air temperature in K,  $g$  is the acceleration due to gravity and  $h$  is the height. For equilibrium at a height  $H$ , the velocity of the fluid element should be equal to the entrance velocity of supply air ( $V_o$ ), i.e.,

$$V_t = V_o \text{ at equilibrium} \quad (39.5)$$

Then from Eqn.(39.1):

$$V_o^2 = gH \left( \frac{\Delta T_d}{T_r} \right) \quad (39.6)$$

where  $\Delta T_d$  is the difference between the temperature of air at supply outlet and the room air.



The **Archimedes number**,  $Ar$  is then defined as:

$$Ar = \frac{gH}{V_o^2} \left( \frac{\Delta T_d}{T_r} \right) \quad (39.7)$$

In the above expression for Archimedes number,  $H$  may be the height of the room or the hydraulic diameter,  $D_h$  of the room given by:

$$D_h = \frac{4WH}{2(W+H)} \quad (39.8)$$

where  $W$  and  $H$  are the width and height of the room, respectively. Archimedes number conveniently combines the supply air velocity at the outlet, supply to room temperature difference and the principle dimensions of the room- important factors that define the air distribution in a room. Several studies show that the airflow pattern in a room is largely dependent on the Archimedes number. The Archimedes number can also be viewed as a ratio of Grashof number to the square of Reynolds number ( $Ar \approx Gr/Re^2$ ), thus combining the effects of natural convection due to buoyancy and forced convection due to supply air jet. Archimedes number also affects the heat transfer between the air inside the conditioned space and the surrounding surfaces. To avoid cold drafts in the occupied zone, the Archimedes number should not exceed a maximum value, which depends on the room dimensions. Table 39.2 shows the maximum Archimedes number values as a function of  $W/H$  ratio.

<b>W/H</b>	<b>4.7</b>	<b>3.0</b>	<b>2.0</b>	<b>1.0</b>
<b><math>Ar_{max}</math></b>	<b>2000</b>	<b>3000</b>	<b>10000</b>	<b>11000</b>

**Table 39.2: Maximum recommended Archimedes number values to avoid draft**

### 39.2.2. Deflection:

When an air stream strikes a solid surface such as a concrete beam or a wall, it deflects. Again from comfort criteria, it is essential to ensure that due to deflection, the supply air does not strike the occupants before it is diffused. Figure 39.1(b) shows the deflection of a supply air jet as it strikes a solid beam.

### 39.3. Behaviour of free-stream jet:

The following aspects are important in understanding the behaviour of free-stream jets:

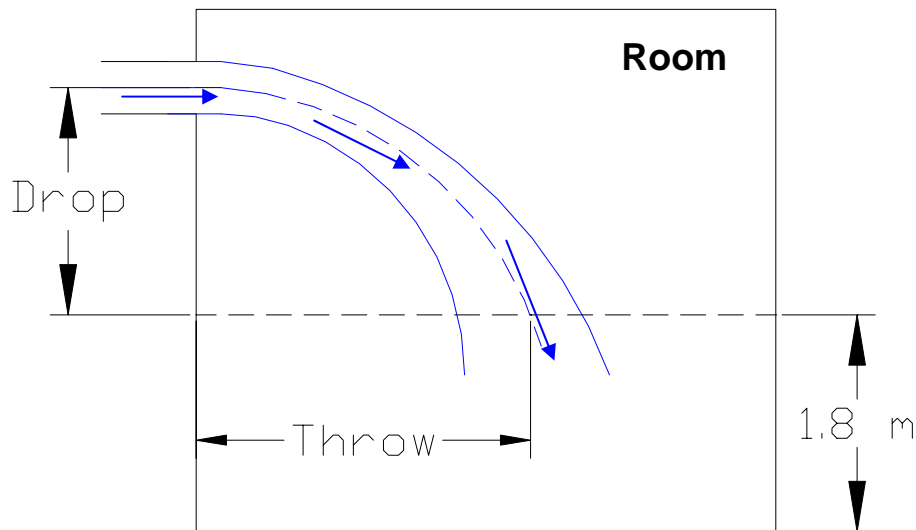
#### **Blow or throw:**

It is the distance traveled by the air stream in horizontal direction on leaving the supply air outlet and reaching a velocity of 0.25 m/s. The velocity should be measured at a height of 1.8 m above the floor level. In air conditioning, the desirable length of blow is upto  $3/4^{\text{th}}$  of the distance to the opposite side of the wall.

### Drop:

It is the vertical distance the air moves after leaving the supply outlet and reaches the end of blow.

Figure 39.2 shows the meaning of drop and throw of free-stream jets.



**Fig.39.2.** Definition of drop and throw

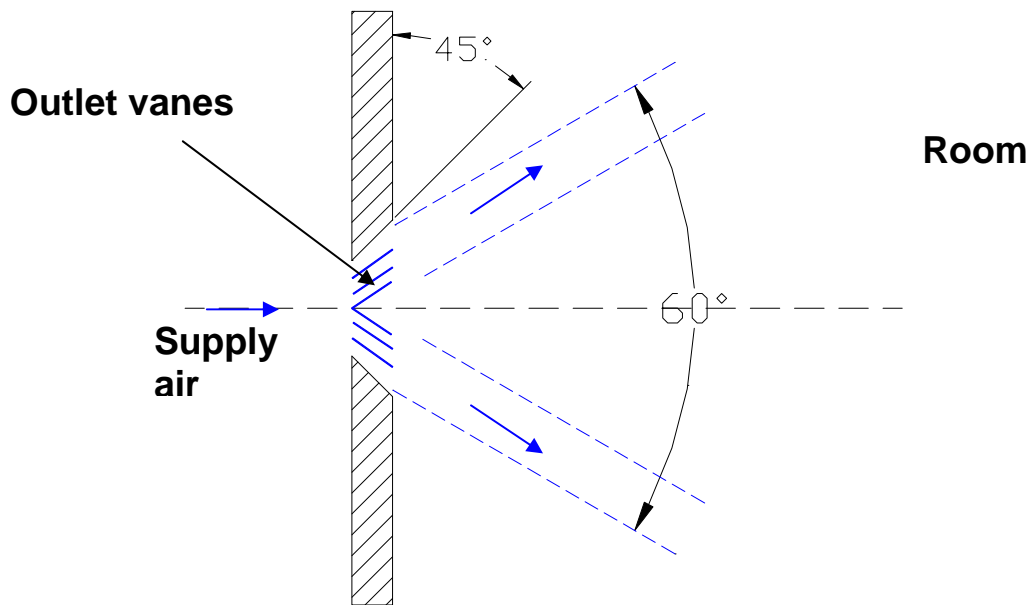
### Entrainment ratio:

As the high velocity jet (called as primary air) leaves the supply air outlet, it entrains some amount of room air (called as secondary air). Entrainment gives rise to motion of room air. The entrainment ratio at a distance  $x$  from the supply outlet is defined as the ratio of volumetric flow rate of air at  $x$  to the volumetric flow rate of air at the supply air outlet ( $x=0$ ), i.e.,

$$\text{Entrainment ratio at } x, R_x = \frac{Q_x}{Q_{x=0}} \quad (39.9)$$

### Spread:

It is the angle of divergence of the air stream after it leaves the supply air outlet as shown in Fig.39.3. The spread can be both horizontal as well as vertical. Vanes are normally used in the supply air outlets. These vanes can be straight, converging or diverging. Figure 39.3 shows the outlet with diverging vanes, for which the horizontal spread is  $60^\circ$  as shown in the figure. For straight vanes and converging the spread is equal to  $19^\circ$  both in horizontal and vertical directions. Converging vanes yield a blow that is about 15% longer than that of straight vanes, whereas for diverging vanes it is about 50% less than that of horizontal vanes.



**Fig.39.3:** Spread of an air jet with diverging vanes

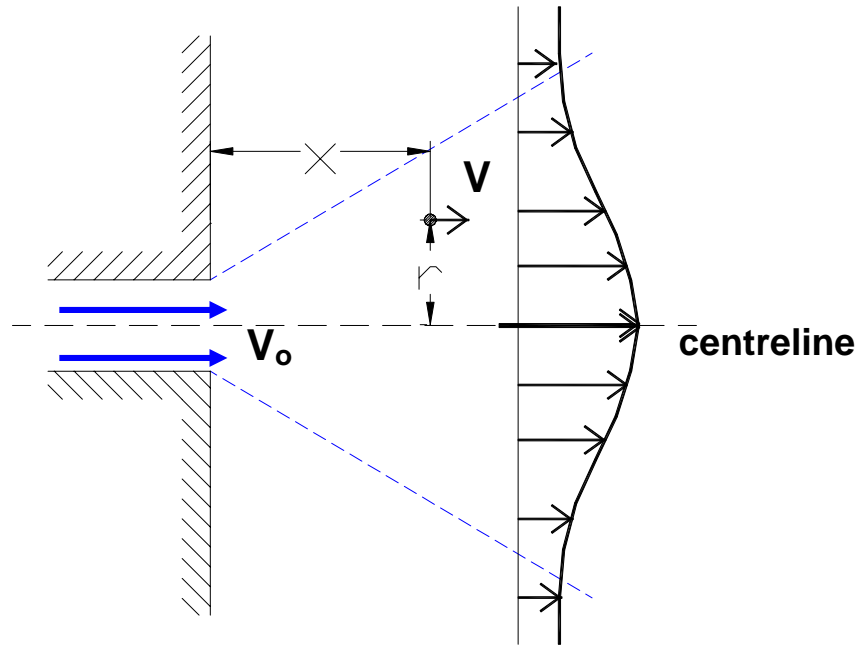
### 39.4. Circular jets:

An understanding of the principle of the simple circular jet can be used to understand the characteristics of most of the commercial supply air diffusers and grilles. Figure 39.4 shows the airflow pattern in a circular jet. As shown in the figure, supply air leaves the outlet at a velocity  $V_o$ . The velocity decays as the jet enters the room and entrains the room air. Figure 39.4 also shows the velocity profile. It can be seen that the velocity of air varies as a function of distance, horizontal  $x$  from the opening along the centerline and the radial distance from the centerline.

Using the mass and momentum balance equations to the circular jet, it has been shown by Schlichting that the velocity profile for the circular jet is given by:

$$V(x,r) = \frac{7.41 V_o \sqrt{A_o}}{x \left[ 1 + 57.5 \left( \frac{r^2}{x^2} \right) \right]^2} \quad (39.10)$$

where  $V_o$  is the velocity at the outlet, m/s;  $V(x,r)$  is the velocity of air in the jet at  $x$  and  $r$ , and  $A_o$  is the cross-sectional area of the outlet. From the above equation it is easy to predict that the air velocity in the circular jet decreases as  $x$  and  $r$  increase, and as  $A_o$  and  $V_o$  decrease. Thus a jet sustains its velocity better as the velocity at the supply outlet increases and/or the area of opening increases. One can also deduce that since the velocity decreases with  $x$  and  $r$ , the jet spreads as it flows, so that the mass of air is always conserved. And from momentum conservation, it can be deduced that entrainment of room air takes place as the jet moves away from the supply air outlet.



**Fig.39.4:** Velocity distribution through a circular jet

From Eqn.(39.10), the velocity of air in the circular jet along the centerline ( $r=0$ ) is found to be:

$$V(x, r = 0) = \frac{7.41 V_0 \sqrt{A_0}}{x} \quad (39.11)$$

From the above expression, the entrainment ratio  $R_x$  for the circular jet can be written as:

$$R_x = \frac{Q_x}{Q_{x=0}} = \frac{\int_{r=0}^{\infty} V(x, r) \cdot 2\pi r \cdot dr}{A_0 V_0} = \frac{0.405 x}{\sqrt{A_0}} \quad (39.12)$$

Large circular openings are rarely used in actual air distribution systems as they travel long distances before mixing with room air. As this can cause discomfort to the occupants, normally diffusers are used in circular jets. These diffusers provide rapid velocity decay and large entrainment.

### 39.5. Rectangular jets:

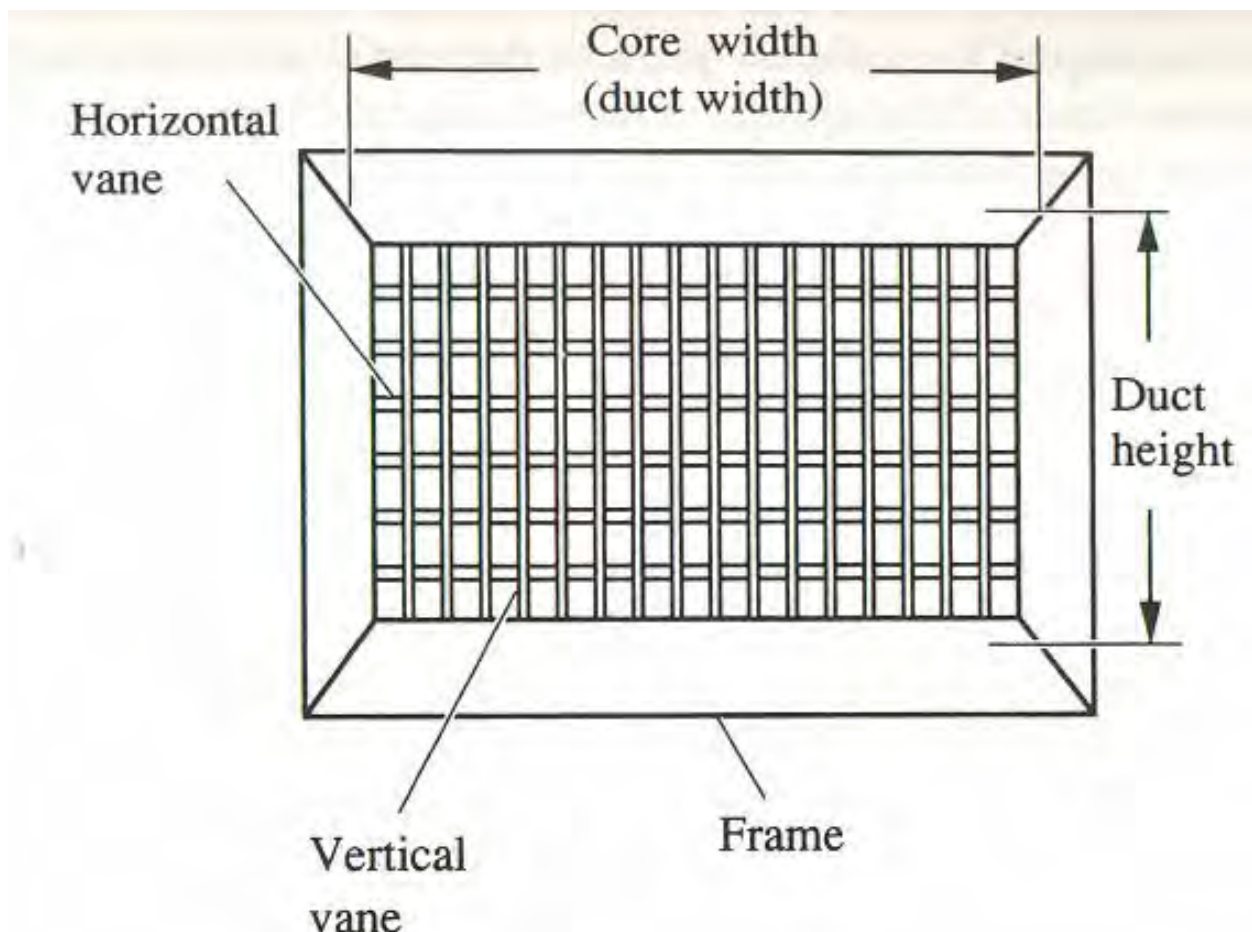
Long, rectangular grilles are commonly used for distributing air in conditioned space. These grilles can be modeled using equations of rectangular jet. It has been shown that for a rectangular jet, the velocity distribution is given by:

$$V(x, y) = \frac{2.40 V_0 \sqrt{b}}{\sqrt{x}} \left[ 1 - \tanh^2 \left( 7.67 \frac{y}{x} \right) \right] \quad (39.13)$$

where  $b$  is the width of the opening and  $y$  is the normal distance from the central plane. A comparison between circular and rectangular jets shows that the centerline velocity decreases more rapidly for a circular jet compared to a rectangular jet. The rectangular jet entrains less air than a circular jet, as a result it decelerates more slowly.

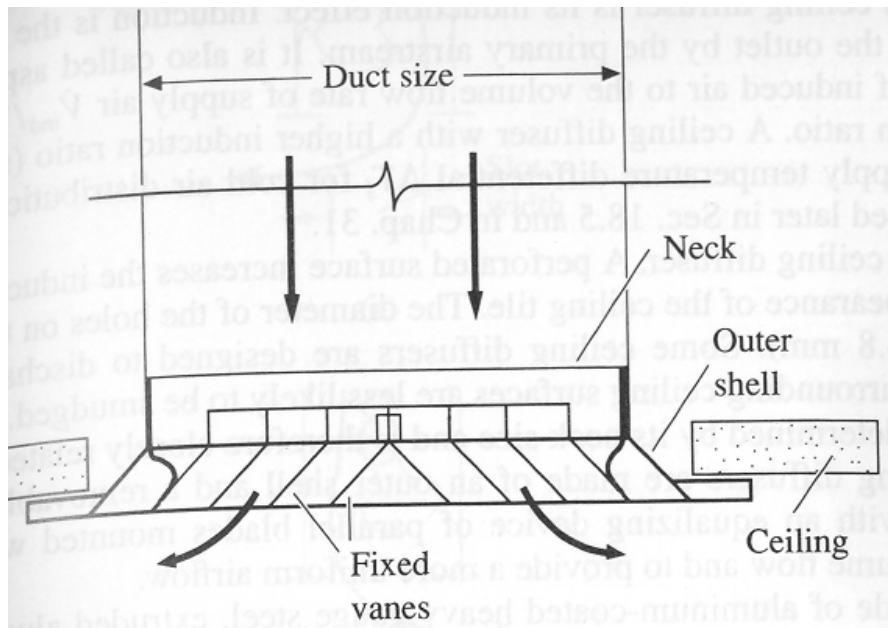
### 39.6. Types of air distribution devices:

**Grilles and Registers:** A grille is an outlet for supply air or an inlet for return air. A register is a grille with a volume control damper. Figure 39.5 shows the front view of a supply air grille with horizontal and vertical vanes. The vanes, either fixed or adjustable are used for deflecting airflow. Grilles have a comparatively lower entrainment ratio, greater drop, longer throw and higher air velocities in the occupied zone compared to slot and ceiling diffusers. Manufacturers specify the performance of the grill in terms of core size or core area, volumetric flow rate of air, effective air velocity, total pressure drop, throw and noise levels. They can be mounted either on the sidewalls or in the ceiling.

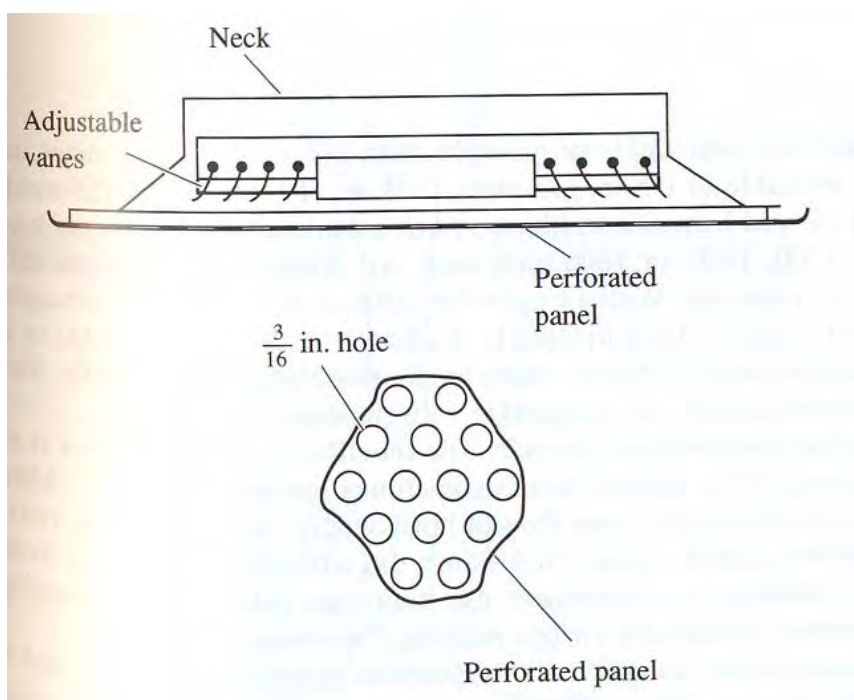


**Fig. 39.5.** Front view of a supply air grille with horizontal and vertical vanes

**Ceiling diffusers:** A ceiling diffuser consists of concentric rings or inner cones made up of vanes arranged in fixed directions. Ceiling diffusers can be round, square or rectangular in shape. Figure 39.6 (a) shows square and rectangular ceiling diffuser, and Fig. 39.6(b) shows a perforated diffuser. A square diffuser is widely used for supply air. In the diffusers the supply air is discharged through the concentric air passages in all directions. The air distribution pattern can be changed by adjusting the adjustable inner cones or the deflecting vanes. Ceiling diffusers are normally mounted at the center of the conditioned space. Ceiling diffusers provide large entrainment ratio and shorter throw, hence are suitable for higher supply air temperatures and for conditioned spaces with low head space. Ceiling diffusers can deliver more air compared to grilles and slot diffusers.

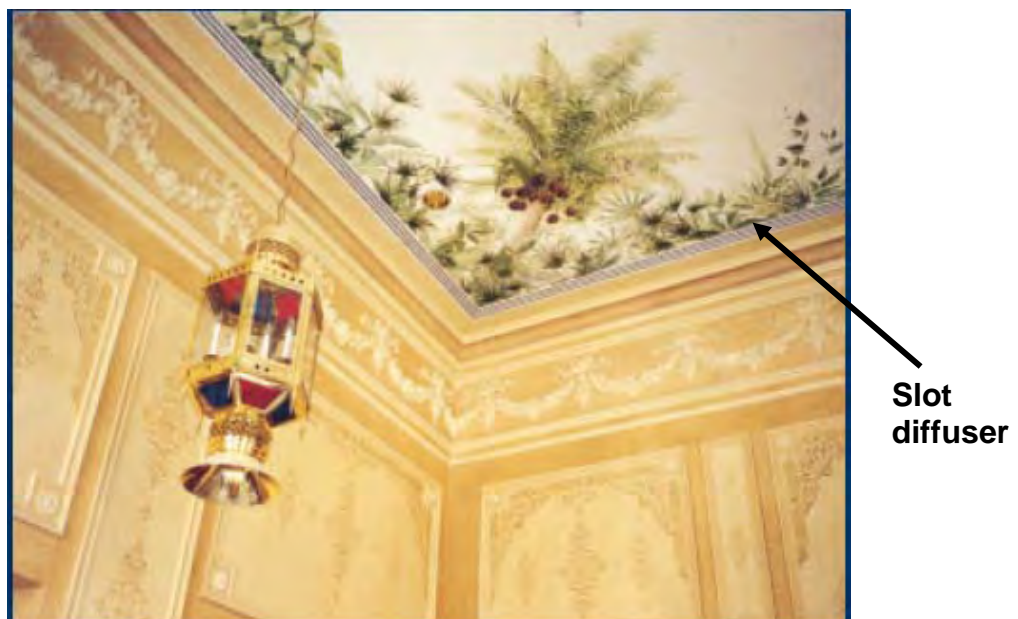


**Fig.39.6(a):** Schematic of a ceiling diffuser



**Fig.39.6(b):** Schematic of a perforated ceiling diffuser

**Slot diffusers:** A slot diffuser consists of a plenum box with single or multiple slots and air deflecting vanes. These are mounted either on the side walls or in the ceiling. Linear slot diffusers mounted on the sidewalls can be as long as 30 meters. These are used for both supply air and return air. Linear slot diffusers are particularly suitable for large open-spaces that require flexibility to suit changing occupant distribution. Figures 39.7(a) and (b) show photograph of conditioned space with linear slot diffusers mounted in the ceiling.

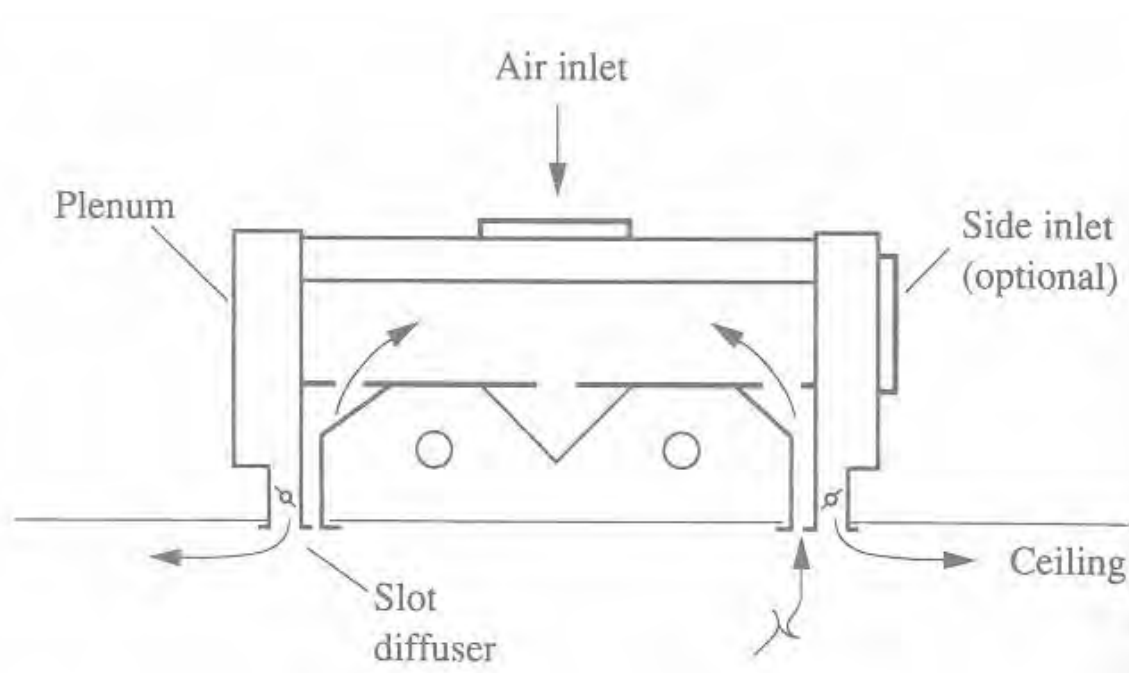


**Fig.39.7(a) and (b):** Photographs of conditioned space with linear slot diffusers mounted in the ceiling

**Light Troffer-Diffuser:** A light troffer-diffuser combines a fluorescent light troffer and a slot diffuser. The slot can be used either as supply air outlet or return air inlet. Light troffer-diffusers offer the following advantages:

- a) The luminous efficiency of fluorescent lamps can be increased by maintaining lower air temperature in the light troffer
- b) An integrated layout of light troffer, diffuser and return slots can be formed on suspended ceilings
- c) Improved aesthetics
- d) A combination of light troffer and return slot reduces the space cooling load as the return air absorbs a part of the heat emitted by the lights. However, they should be designed such that the return air does not come in direct contact with the tube so that deposition of dust on the fluorescent tube is prevented

Figure 39.8 shows a light troffer-diffuser slot that combines the light troffer, supply air diffuser and return air slot.



**Fig.39.8:** Light troffer-diffuser slot

In addition to the above air distribution devices, the **floor mounted grilles and diffusers, low-side wall diffusers, nozzle diffusers** etc. are also used for room air distribution.



### 39.7. Return air inlets:

Different types of return air inlets are used to return the space air to the air handling unit. Requirements of return air inlets are:

- a) They should not lead to short-circuiting of supply air
- b) Undesirable products such as tobacco smoke, odours etc. should be able to move in their natural direction so that they do not stagnate in the occupied space. To eliminate tobacco smoke, the return air inlets should be placed high in the wall, whereas to remove dust particles etc. the return air inlets should be placed in the floor so that these particles do not float in air.

Similar to supply air outlets, return air inlets can be classified as grilles, registers, diffusers etc. In many commercial buildings the ceiling plenum is used as return air plenum. In this case, return slots are used to draw the return air through the ceiling. In return air inlets the air velocity decreases sharply as the distance from the inlet increases. Based on noise criteria, the air velocity should be within 3 m/s if the return air inlet is inside the occupied space and it should be less than 4 m/s if it is above the occupied space.

### 39.8. Airflow patterns inside conditioned space:

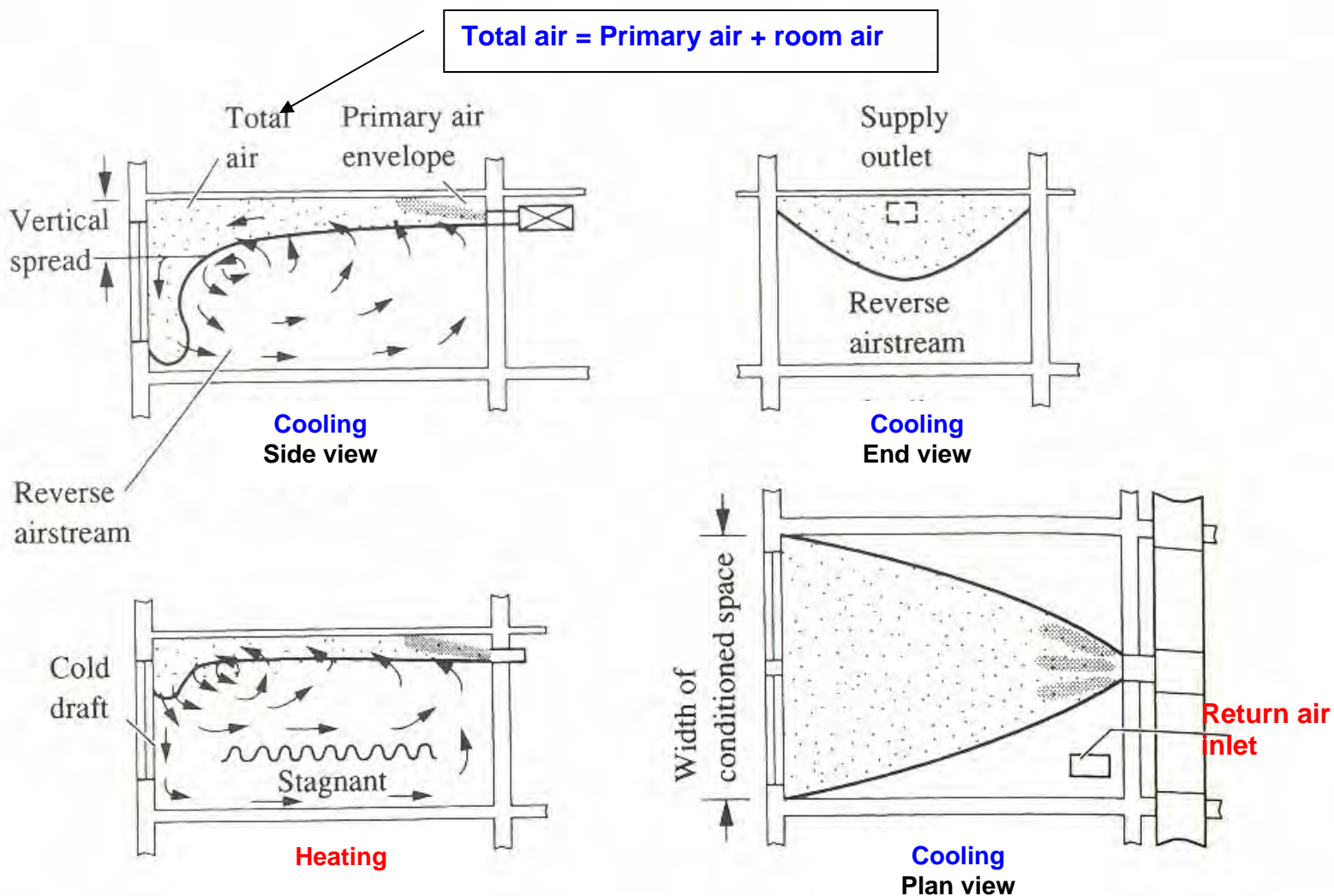
In most of the air conditioned buildings air is supplied at a temperature between 10 to 15.6°C and with a velocity in the range of 2 to 4 m/s. This air has to mix thoroughly with the room air so that when it reaches the occupied zone its temperature should be around 22.2 to 23.3°C and its velocity is less than 0.36 m/s to avoid draft. The mixing airflow patterns should have the following characteristics:

- a) Entrainment of room air to reduce the air temperature and velocity in the occupied zone to acceptable levels
- b) Reverse air stream in the occupied zone for an even velocity and temperature distribution
- c) Minimization of stagnant areas in the occupied space. A stagnant area is zone in which the natural convective currents prevail and the velocity is less than about 0.1 m/s. Reverse air stream reduces the stagnant areas in the occupied zone

The airflow pattern in the conditioned space is influenced mainly by the type and location of supply air outlets. The high side outlets, ceiling diffusers and slot diffusers are most commonly used in air conditioned buildings.

Figure 39.9 shows the airflow pattern using high side outlets installed on a high sidewall for cooling and heating applications. As the air is discharged from the high side outlet, due to surface effect (**Coanda effect**) the air jet tends to stick to the ceiling as shown in the figure. For cooling applications, the cold supply air entrains the room air and deflects downwards when it strikes the opposite wall. The reverse

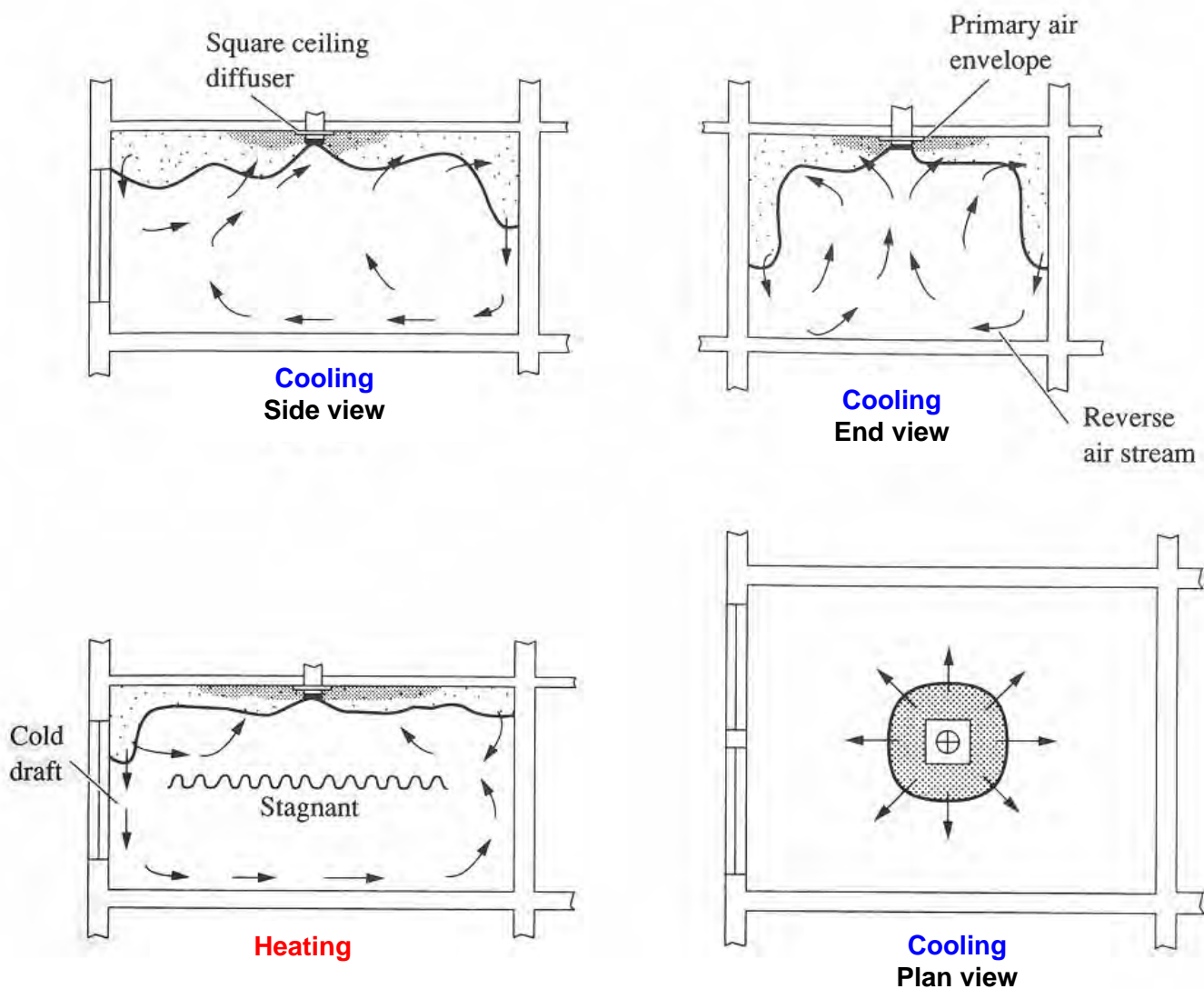
air stream formed due to entrainment fills the occupied space as shown. If the throw is longer than the length of the room and height of the opposite wall, then the air jet is deflected by the opposite wall and the floor and enters the occupied zone with high velocity. On the other hand if the throw is too small, then the air jet drops directly into the occupied zone before it strikes the opposite wall. Thus both these i.e, a very long or very short throw can cause draft. For heating, a stagnant zone may form as shown due to buoyancy effect. However, if the throw is long, the reverse flow can minimize the stagnant area during heating. For high sidewall outlet, the most suitable location for return air inlet is on the ceiling outside the air jet as shown in the figure.



**Fig.39.9:** Airflow pattern using high side outlets for cooling and heating applications

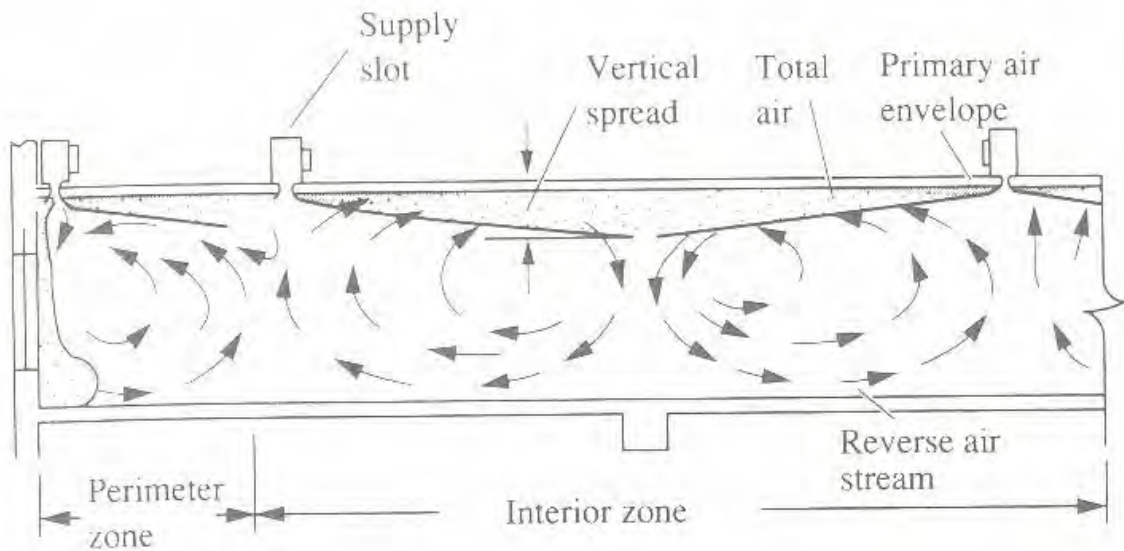
Figure 39.10 shows the airflow pattern using ceiling diffusers for both cooling and heating applications. It is seen that ceiling diffusers produce a shorter throw, a lower and more even distribution of air velocity and a more even temperature in the occupied zone when used for cooling. However, when used for heating it is seen that a larger stagnant area is formed due to buoyancy effect. Ceiling diffusers are widely

used for conditioned spaces with limited ceiling height and are designed to have a large entrainment ratio and are widely used in variable air volume systems.



**Fig.39.10:** Airflow pattern using ceiling diffusers for cooling and heating applications

Figure 39.11 shows the airflow patterns obtained using slot diffusers installed in the ceiling in the perimeter and interior zones. The slot diffusers installed in the perimeter zone discharge air vertically downwards and also in the horizontal direction. Due to its better surface effect, the air jet remains in contact with the ceiling for a longer period and the reverse air stream ensures uniformity of temperature and velocity in the occupied zone. Due to their superior characteristics and better aesthetics, slot diffusers are widely used in large office spaces with normal ceiling heights and with VAV systems.



**Fig.39.11:** Airflow pattern for cooling using slot diffusers

### 39.9: Stratified mixing flow:

In buildings with a high ceiling, it is more economical to stratify the conditioned space into a stratified upper zone and a cooled lower zone. In such cases the supply air outlet is located at the upper boundary of the cooled lower zone and the air jet is projected horizontally. The cold air supply takes care of the cooling load in the lower zone due to windows, walls, occupants and equipment. Radiant heat from the roof, upper external walls and lights installed in the roof enter the occupied zone and are converted into cooling load with a thermal lag.

Stratified mixing flow for summer cooling offers the following advantages:

- Convective heat transfer from the hot roof is effectively blocked by the higher temperature air in the stagnant upper zone thus reducing the building cooling load
- Location of the return air inlets affects the cooling load only when they are located in the upper zone

### 39.10: Cold air distribution:

When chilled water is available at a lower temperature of about 1 to 2°C (e.g. using an ice storage system), the supply air temperature can be reduced to about 4.4 to 7.2°C, instead of the usual temperature of about 13°C. Such a system is called a cold air distribution system. These systems offer the following advantages when compared with the conventional systems:

- Due to the lower dew-point temperature, the space humidity can be maintained between 35 to 45 %, as a result the occupied space can be maintained at a slightly higher temperature without causing discomfort

- b) Due to the lower supply temperature, the flow rate of supply air can be reduced significantly leading to smaller ducts and hence smaller building space requirement and associated benefits
- c) Due to lower flow rates, fan power consumption can be reduced by as much as 40 percent
- d) Noise levels in the conditioned space can be reduced due to reduced flow rates

However, due to considerably reduced airflow rates, the air distribution and IAQ may get affected, especially when using with VAV systems. Better insulation and sealing of the ducts may be required to reduce losses and prevent surface condensation.

### 39.11: Displacement flow:

Displacement flow is a flow pattern in which cold supply air supplied at a velocity that is almost equal to the velocity in the conditioned zone and a temperature that is only slightly lower than the occupied zone, enters the occupied zone and displaces the original space air with a piston like motion without mixing with the room air. Displacement flow when designed properly, provides better Indoor Air Quality (IAQ) with lower turbulent intensity and lower draft in the occupied zone. Displacement flow can be classified into downward unidirectional flow and horizontal unidirectional flow. Figures 39.12(a), (b) and (c) shows the schematic of a downward unidirectional flow system, a horizontal unidirectional flow system and a unidirectional flow system for work stations, respectively. As mentioned before, due to the possibility of achieving superior IAQ, displacement flow systems are used widely in clean rooms, in operation theatres etc. Previously, displacement flow was known as laminar flow. However, in an air conditioned building with forced air circulation, the air flow in the occupied zone is turbulent everywhere except in the boundary layers near the walls (where the flow is laminar), even when the velocities are very low (Reynolds number is usually greater than 10000).

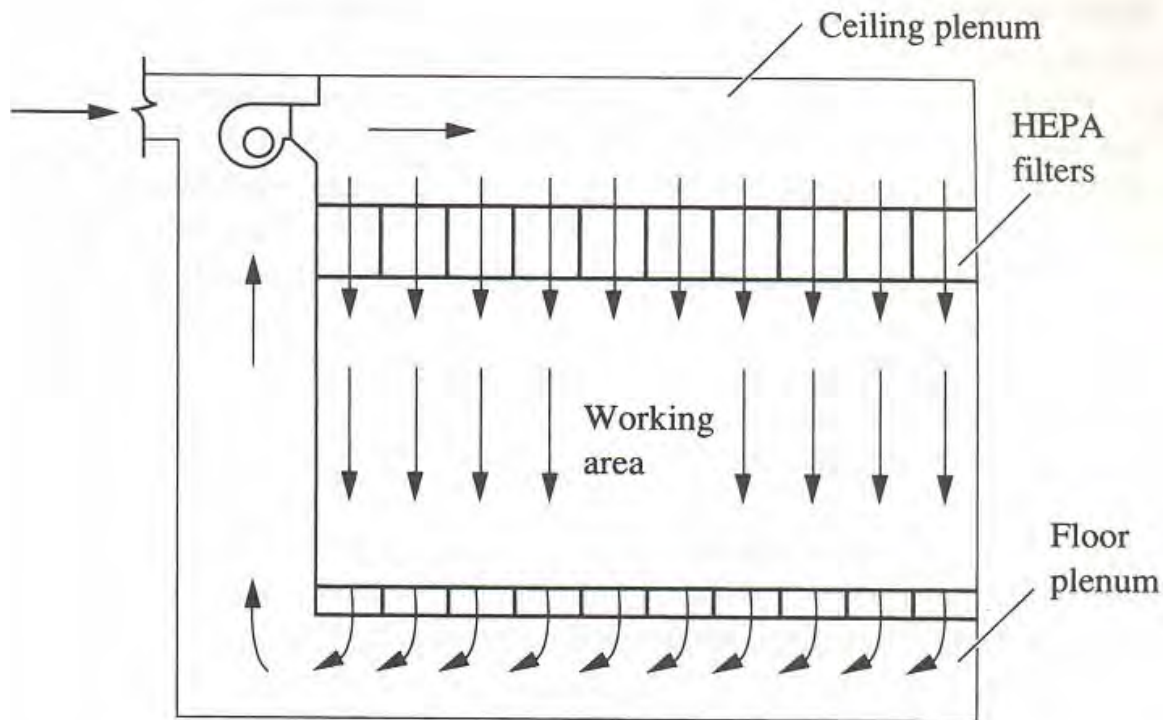
### 39.12. Spot cooling/heating:

In these systems cold or warm air jet is projected directly into a part of the occupied zone, often called as target zone, so that thermal environment can be controlled locally. Spot cooling/heating offers several advantages such as:

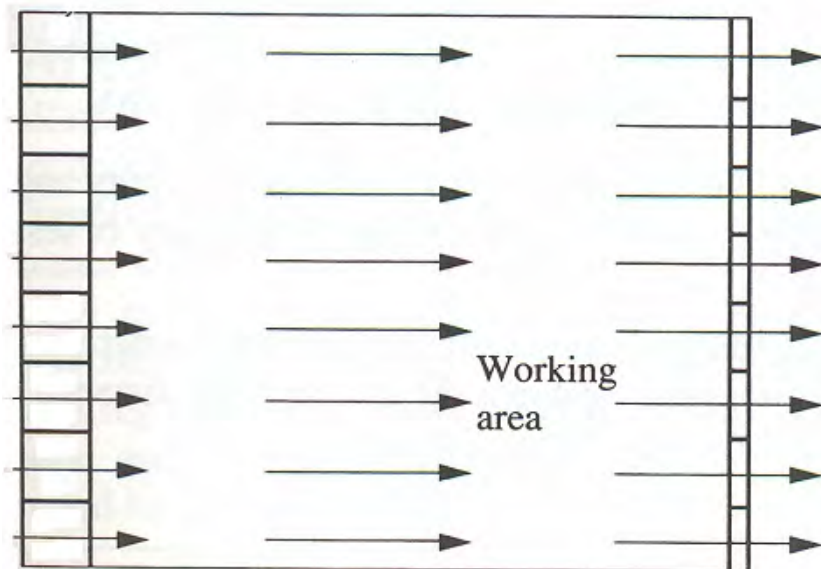
- a) Better control of temperature, air purity and movement in a localized area, thus improving the thermal comfort of the occupants
- b) Possibility of using greater outdoor air for ventilation
- c) Highly localized loads can be handled very efficiently
- d) Occupants have greater control of their own personalized environment

However spot cooling/heating have certain disadvantages such as: possibility of draft, discomfort due to air jet pressure, limited area of environment control and a complex air distribution system. Spot cooling systems can be classified into industrial spot cooling systems and desktop task air conditioning systems. As the name implies, industrial spot cooling systems are used in large industrial areas such as

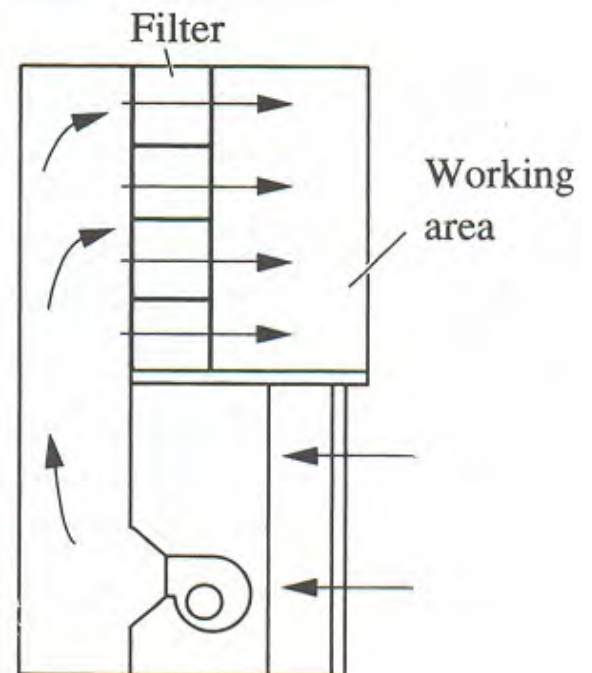
large machine shops, steel plants etc. Desktop task air conditioning systems find application in large office buildings.



**Fig.39.12(a):** Downward unidirectional flow



**Fig.39.12(b):** Horizontal unidirectional flow



**Fig.39.12(c):** Unidirectional flow for work stations

### 39.13. Selection of supply air outlets:

Selection depends on:

1. **Requirement of indoor environment control:** If the indoor environment requires controlled air movement, then a high side outlet should not be used
2. **Shape, size and ceiling height of the building:** Ceiling and slot diffusers are ideal for buildings with limited ceiling height. For large buildings with large ceiling heights, high side wall mounted outlets are recommended.
3. **Volume flow rate per unit floor area:** Sidewall outlets are limited to low specific volume flow rates as they give rise to higher air velocities in the occupied zone. Compared to slot diffusers, the ceiling diffusers can handle efficiently a larger volumetric flow rates. Table 39.3 shows the specific volume flow rate of different outlets
4. **Volume flow rate per outlet:** The volume flow rate per supply outlet depends on the throw required to provide a satisfactory room air distribution. For linear slot diffusers, the volume flow rate per unit length is important. Its value normally lies between 23 to 62 L/s.m for linear slot diffusers. In a closed office with a floor area of about 14 m<sup>2</sup> and only one external wall, one ceiling diffuser is normally sufficient
5. **Throw:** High side wall outlets have a longer throw than ceiling diffusers. Square ceiling diffusers and circular ceiling diffusers have similar throw
6. **Noise level**
7. **Total pressure drop:** The total pressure loss of supply air as it flows through a slot diffuser of 19 mm width is normally between 12 to 50 Pascals, whereas it is between 5 to 50 Pascals for ceiling diffuser. Normally the pressure loss across the supply outlet should not exceed 50 Pascals
8. **Cost and Appearance:** Finally the cost and appearance of the supply air outlets also have to be considered depending upon the specific application

Performance of various types of supply air outlets are provided by the manufacturers in the form of tables and charts, using which one can select a suitable supply air outlet.

Type of outlet	Specific volume flow rate L/s/m <sup>2</sup> of floor area	Max. ACH for 3-m ceiling
Grilles	3.0 to 6.0	7
Slot diffuser	4.0 to 20.0	12
Perforated Panel	4.5 to 15.0	18
Ceiling diffuser	4.5 to 25.0	30

**Table 39.3:** Specific volume flow rates of different outlet devices

## Questions and answers:

1. State which of the following statements are TRUE?

- a) The purpose of an air distribution system is to maintain comfort conditions in the entire conditioned space
- b) The purpose of an air distribution system is to maintain comfort conditions in the occupied zone of the conditioned space
- c) The effective draft temperature depends on dry bulb temperature and relative humidity of air
- d) The effective draft temperature depends on dry bulb temperature and velocity of air

**Ans.: b) and d)**

2. State which of the following statements are TRUE?

- a) The effective draft temperature increases as dry bulb temperature and air velocity increase
- b) The effective draft temperature increases as dry bulb temperature increases and air velocity decreases
- c) A good air distribution system should yield high value of ADPI and a small value of SDEF
- d) A good air distribution system should yield high values of both ADPI and SDEF

**Ans.: b) and d)**

3. State which of the following statements are TRUE?

- a) Due to buoyancy effect a cold air stream rises and a hot air stream drops
- b) The buoyancy effects become stronger as the temperature difference between the supply air and room air increases
- c) A high Archimedes number indicates a strong buoyancy effect
- d) The design Archimedes number should increase as the height of the room decreases

**Ans.: b) and c)**

4. State which of the following statements are TRUE?

- a) The centerline velocity of air from a circular jet increases as the distance from the outlet increases
- b) The centerline velocity of air from a circular jet increases as the outlet area decreases
- c) The centerline velocity of air from a circular jet increases as the supply air velocity at the outlet increases
- d) All of the above

**Ans.: c)**



5. State which of the following statements are TRUE?

- a) Compared to other outlet types, a grille has lower entrainment ratio and greater drop
- b) Ceiling diffusers are recommended when the ceiling height is high
- c) Sidewall diffusers are generally used in large spaces
- d) All of the above

**Ans.: a) and c)**

6. State which of the following statements are TRUE?

- a) A light-troffer-diffuser-slot improves the efficiency of the fluorescent lights
- b) A light-troffer-diffuser-slot reduces the room sensible heat factor
- c) To eliminate tobacco smoke, return air inlets should be located at a lower height on the wall
- d) Design of return air inlet is important from noise point-of-view

**Ans.: a), b) and d)**

7. State which of the following statements are TRUE?

- a) Stratified mixing flows are recommended for buildings with high ceilings
- b) Stratified mixing flow reduces the radiant heat load from the ceilings
- c) Cold air distribution systems reduce the space requirement and fan power
- d) Cold air distribution systems may lead to surface condensation

**Ans.: a), c) and d)**

8. State which of the following statements are TRUE?

- a) Displacement flows are recommended in operation theatres due to better IAQ
- b) In displacement flow system, supply air temperature is only slightly different from comfort temperature
- c) In displacement flow system, supply air velocity is low
- d) All of the above

**Ans.: d)**

9. State which of the following statements are TRUE?

- a) Spot cooling and heating systems are widely used in industrial applications
- b) Spot cooling and heating systems provide better individual control
- c) Spot cooling and heating systems reduce the total cooling load
- d) All of the above

**Ans.: d)**

10. The following table shows the measurements made at 9 points in the occupied zone of an air conditioned building. Evaluate the design of the air distribution system.

Measuring point	DBT (°C)	Air velocity (m/s)	EDT (°C)
1.	21.1	0.30	-3.32
2.	21.7	0.25	-2.71
3.	22.5	0.20	-1.91
4.	23.5	0.21	-0.91
5.	24.1	0.10	-0.29
6.	24.7	0.08	+0.31
7.	23.7	0.11	-0.69
8.	22.8	0.19	-1.61
9.	22.0	0.24	-2.41

**Ans.:** From the DBT and air velocity (V) data, the Effective Draft Temperature (EDT) for each point is calculated using the equation:

$$EDT = (DBT - 24.4) - 0.1276(V - 0.15)$$

The calculated EDT values are shown in the table. It is seen from the table that the EDT value varies widely from  $-3.31^{\circ}\text{C}$  to  $+0.3^{\circ}\text{C}$ , indicating improper distribution.

For this space the Air Distribution Performance Index (ADPI) is calculated using the equation:

$$ADPI = \left( \frac{N_0}{N} \right) \times 100 = \left( \frac{5}{9} \right) \times 100 = 55.6 \quad (\text{Ans.})$$

where  $N_0$  is the number of locations at which the effective draft temperature is within  $-1.7^{\circ}\text{C}$  to  $+1.1^{\circ}\text{C}$ .

An ADPI value of 55.6 indicates the need for improving the design of the air distribution system, as it indirectly indicates that only about 56% of the occupied zone meets the comfort criteria, whereas the remaining space gives rise to drafts.

11. The velocity of air issuing from a circular opening is given by the following equation:

$$V(x,r) = \frac{7.41V_o\sqrt{A_o}}{x\left[1 + 57.5\left(\frac{r^2}{x^2}\right)\right]^2}$$

where  $V_o$  is the velocity at supply air outlet ( $x=0$ ),  $A_o$  is the area of the opening,  $r$  is the radial distance from the centerline and  $V(x,r)$  is the velocity at point  $(x,r)$ . An airflow rate of  $0.12 \text{ m}^3/\text{s}$  is supplied through a circular opening at a velocity of  $3 \text{ m/s}$ . Find the distance from the outlet at which the centerline velocity reduces to  $1 \text{ m/s}$ . What is the total airflow rate (primary + secondary) at this point?

**Ans.:** The expression for centerline velocity ( $r=0,x$ ) is given by:

$$V(x,r = 0) = \frac{7.41V_o\sqrt{A_o}}{x}$$

Area of the opening,  $A_o = Q_o/V_o = 0.12/3 = 0.04 \text{ m}^2$

Substituting the values of  $V(x,r=0) = 1 \text{ m/s}$ ,  $V_o = 3 \text{ m/s}$  and  $A_o = 0.04 \text{ m}^2$  in the above expression, we find the value of  $x$  as:

$$x = \frac{7.41V_o\sqrt{A_o}}{V(x,r = 0)} = \frac{7.41 \times 3 \times \sqrt{0.04}}{1.0} = 4.446 \text{ m} \quad (\text{Ans.})$$

The total airflow rate at  $x = 4.446 \text{ m}$  is obtained from the equation:

$$Q_{x = 4.446 \text{ m}} = Q_{x=0} \cdot R_x$$

Where  $R_x$  is the entrainment ratio, given by:

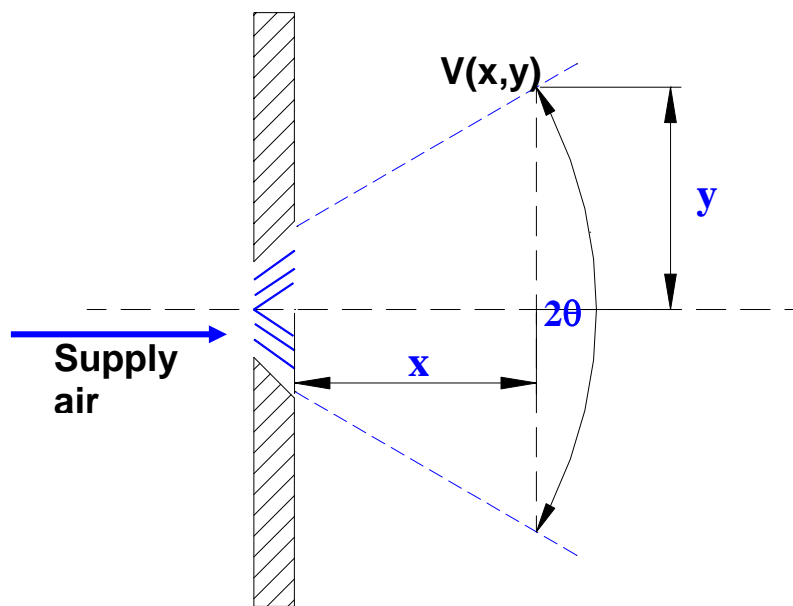
$$R_x = \frac{Q_{x=4.446}}{Q_{x=0}} = \frac{\int_{r=0}^{\infty} V(x,r) \cdot 2\pi r \cdot dr}{A_o V_o} = \frac{0.405 x}{\sqrt{A_o}} = \frac{0.405 \times 4.446}{\sqrt{0.04}} \approx 9.0$$

$$\text{hence, } Q_{x = 4.446} = Q_{x=0} \times 9.0 = 0.12 \times 9.0 = 1.08 \text{ m}^3/\text{s} \quad (\text{Ans.})$$

12. The velocity distribution of air from an air jet issued from a long, narrow slot is given by the following equation:

$$V(x, y) = \frac{2.4 V_o \sqrt{b}}{\sqrt{x}} \left[ 1 - \tanh^2 \left( 7.67 \frac{y}{x} \right) \right]$$

where  $V_o$  is the velocity at supply air outlet ( $x=0$ ),  $b$  is the width of the slot,  $y$  is the normal distance from the central plane and  $V(x,y)$  is the velocity at point  $(x,y)$ . Find the ratio of velocity  $V(x,y)$  to  $V(x,y=0)$  at a plane  $x$  at which the spread angle is  $19^\circ$ .



*Definition of spread angle ( $2\theta$ )*

**Ans.:** The spread angle is given by  $2\theta$  as shown in the figure given above.

From the figure,

$$\theta = \tan^{-1}(y/x) = (19/2) = 9.5^\circ$$

$$\therefore \text{at } \theta = 9.5^\circ, (y/x) = \tan(9.5) = 0.1673$$

From the expression for  $V(x,y)$ ;

$$\frac{V(x, y)}{V(x, y = 0)} = \left[ 1 - \tanh^2 \left( 7.67 \frac{y}{x} \right) \right] = \left[ 1 - \tanh^2 (7.67 \times 0.1673) \right] = 0.265 \quad (\text{Ans.})$$

# Lesson

# 40

# Ventilation For Cooling

## The specific objectives of this chapter are to:

1. Discuss the use of ventilated air for cooling of buildings and cooling of occupants (*Section 40.1*)
2. Make a comparison between natural ventilation and mechanical ventilation (*Section 40.2*)
3. Discuss characteristics of natural ventilation and estimation of airflow rate due to wind and stack effects (*Section 40.3*)
4. List the general guidelines for natural ventilation (*Section 40.4*)
5. Discuss briefly forced ventilation using electric fans (*Section 40.5*)
6. Discuss interior air movement using interior fans, unit ventilators, whole house fans and solar chimneys (*Section 40.6*)

At the end of the lecture, the student should be able to:

1. Discuss the effectiveness of ventilated air for cooling of buildings and occupants
2. Compare natural ventilation with mechanical ventilation
3. Estimate airflow rates due to wind effect and stack effect and combined wind and stack effects
4. List the general guidelines for natural ventilation
5. Discuss the benefits of mechanical ventilation using fans
6. Discuss the benefits of interior air movement and ways and means of achieving interior air movement such as the use of fans, ventilators, solar chimneys etc.

### 40.1. Introduction:

In a previous chapter, ventilation has been defined as “[supply of fresh air to the conditioned space either by natural or by mechanical means for the purpose of maintaining acceptable indoor air quality](#)”. However, when outdoor conditions are suitable, the ventilation can also be used for cooling of the buildings, for cooling of the occupants or both.

#### 40.1.1. Ventilation for cooling of buildings:

When the ambient dry bulb temperature is lower than the building temperature, then the outdoor air can be used for cooling the building. Normally due to solar and internal heat gains, buildings can become hotter than the ambient air. This provides an opportunity for cooling the building at least partly, by using the

freely available outdoor air. This can significantly reduce the load on air conditioning plants. Though the cooling of buildings during daytime may not be possible on all days, in an year there are many days during which outdoor air can act as a heat sink for the building. Greater opportunities exist for cooling the buildings especially during the night, when the outdoor air is considerably cooler. This is especially effective for hot and dry climates where the diurnal temperature variation is quite large.

#### 40.1.2. Ventilation for cooling of occupants:

Under certain circumstances, outdoor air can also be used very effectively for cooling the occupants of a building directly. By allowing the outdoor air to flow over the body at a higher velocity, it is possible to enhance the heat and mass transfer rates from the body, thus leading to a greater feeling of comfort. As a thumb rule, studies show that each increase in air velocity by 0.15 m/s will allow the conditioned space temperature to be increased by 1°C. As mentioned before, maintaining the conditioned space at a higher temperature can give rise to significant reduction in the energy consumption of the air conditioning system. However, in general the air velocity if it exceeds about 1.0 m/s may give rise to a feeling of draft or irritation to the occupants.

The cooling effect provided by ventilated outdoor air is mainly sensible in nature, even though, it may also extract latent heat from the occupants if it is cool and dry. The sensible cooling rate provided by the outdoor air  $Q_v$  is given by:

$$Q_v = \dot{m}_v \cdot c_p (T_{ex} - T_o) \quad (40.1)$$

where  $\dot{m}_v$  is the mass flow rate of ventilated air,  $T_o$  and  $T_{ex}$  are the temperature of the outdoor air and temperature of the exhaust air (after cooling), respectively.

#### 40.2. Natural versus mechanical ventilation:

As the name implies, if ventilation is provided by natural means such as the wind or stack effects (i.e. due to temperature difference), then it is called as natural ventilation. If ventilation is provided by using mechanical means such as fans and blowers, then it is called as mechanical ventilation.

Ideally, natural ventilation should be used whenever possible. It is considered as the first line of defense against summer heat. However, relying only on natural ventilation for cooling either buildings and/or occupants may not always be possible or it may impose severe restrictions upon building design. This is due to the uncertain nature of natural ventilation, which depends on outdoor conditions such as the wind and ambient temperatures – two highly variable parameters.

Mechanical ventilation though requires external power input, extends the application of ventilation for cooling. It is also highly controllable and is available as and when required (of course, subject to the availability of electricity) with a relatively small expense of electrical energy. Thus a sensible building design must be such that it makes use of both natural and mechanical ventilation in an optimum manner.

### 40.3. Natural ventilation:

The principle of natural ventilation is very well known and is widely studied. Most of the older buildings before the advent of electricity relied on natural ventilation for maintaining comfortable conditions. However, as mentioned before relying only on natural ventilation imposes several restrictions on building design. For example, windows on opposite walls have to be provided to all the rooms to meet natural ventilation requirements. As a result, large buildings have to be designed in simple T-, L- or H- shapes. The ceiling height has to be high to improve natural ventilation etc. In addition to this, the amount of airflow due to natural ventilation is also uncertain as it depends on:

- a) Magnitude and direction of prevailing winds
- b) Ambient air temperature
- c) Landscaping and adjacent structures
- d) Design of the building and position of windows, doors etc.
- e) Location of furniture
- f) Movement of the occupants, etc.

Due to its uncertain nature, natural ventilation is treated as a secondary objective in the design of modern buildings. Natural ventilation, as discussed in an earlier chapter depends on wind effect and stack effect.

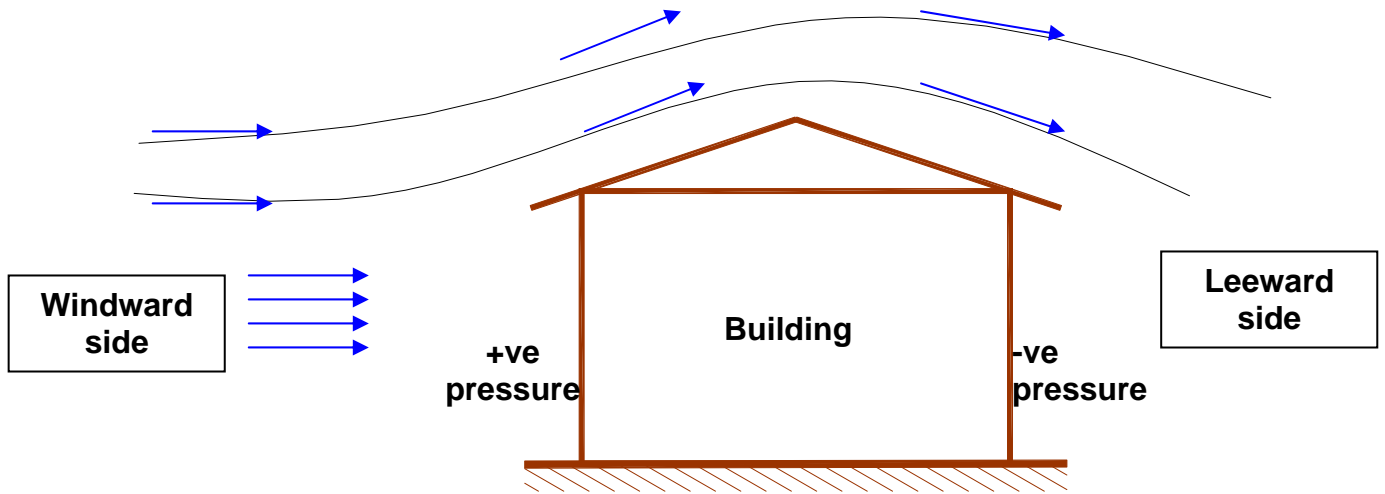
#### 40.3.1. Wind induced, natural ventilation:

When wind blows over a building, a static pressure difference is created over the surface of the building. The pressure difference depends on the wind speed, wind direction, surface orientation and surrounding structures. As shown in Fig.40.1, in an undisturbed air stream, the pressure is positive on the windward direction and negative on the leeward direction. The static pressure on the other surfaces depends upon the angle of attack. This pressure is called as wind pressure. In general, the magnitude of the wind pressure ( $P_w$ ) is proportional to the velocity pressure, and in an ideal case it is given by:

$$P_w = C_p \frac{\rho V_w^2}{2} \quad (40.2)$$

where  $C_p$  is surface pressure coefficient,  $\rho$  is the air density and  $V_w$  is the wind speed. The value of  $C_p$  depends on several factors such as the wind direction, orientation of the building etc. Analytical evaluation of  $C_p$  is quite complicated, even though these values have been measured experimentally for simple structures.





**Fig.40.1:** Wind pressure on a building

The pressure difference across the building due to wind creates a potential for airflow through the building, if openings are available on the building. The airflow rates through the buildings due to wind effect can be obtained approximately using the equation suggested by ASHRAE:

$$\dot{Q}_w = C.R.A.V_w \quad (40.3)$$

Where  $\dot{Q}_w$  is the airflow rate in  $m^3/s$ ,  $A$  is the area of opening ( $m^2$ ),  $C$  is a constant that takes the value of 0.55 for perpendicular winds and 0.30 for oblique winds, and  $R$  is a factor that is function of inlet and outlet areas ( $A_i$  and  $A_o$ ) of the openings. The factor  $R$  varies from 1.0 to about 1.38 depending upon the ratio of inlet and outlet areas.

Estimation of wind speed is difficult, however, data provided by the meteorological departments can be used for calculation purposes. Since the wind speed varies with season, for design calculations 50 percent of the summer wind speed as provided by the meteorological data can be used.

Since the airflow rate due to wind effect is a strong function of the opening or window area, suitable values should be used for design calculations. The areas to be used in the calculations are the net free area of the openings, not the total opening areas. The distribution of opening areas between inlet and outlet is also important. It is shown that the flow rate is maximum when the inlet area is equal to the outlet area. When inlet and outlet areas are not equal, an effective area has to be used in Eqn.(40.3). It is given by:

$$A_{\text{eff}} = \frac{(A_o / A_i)}{(A_o^2 + A_i^2)^{0.5}} \quad (40.4)$$

When outlet area is greater than the inlet area ( $A_o > A_i$ ), then greater speeds are obtained at the inlet compared to the outlets and vice versa. Thus manipulating

the areas, for example by opening or closing some windows, it is possible to achieve higher velocities in certain areas compared to others.

The shape of the window also plays role, if the wind is not perpendicular. For oblique winds, short and wide windows provide better airflow compared to square or narrow and tall windows. In general any window treatment such as curtains, blinds etc. reduce the airflow rate due to wind effect. Architectural features such as overhangs, balconies can be used beneficially to improve the airflow due to wind effect.

#### 40.3.2. Ventilation due to stack effect:

When there is a temperature difference between the indoor and outdoor, airflow takes place due to buoyancy or stack effect. During winter, the indoor air is generally warmer compared to outdoor air, as a result, if there are openings in the building, then warm air inside the building rises due to buoyancy and leaves from the openings provided at the top, while cold outdoor air enters into the building through the openings near the base of the building. The reverse happens during summer, when inside is cooler compared to outside, warm outdoor air enters the building from the top openings and cold indoor air leaves the building from the bottom openings. Generally, due to stack effect, in a building at a particular height, the internal and external pressures become equal. This height is known as **Neutral Pressure Level (NPL)**. Obviously, if openings are provided at the NPL, then no airflow takes place due to stack effect. Knowledge of NPL thus is useful in enhancing airflow due to stack effect. However, estimation of NPL is extremely difficult as it depends on several factors such as distribution of the openings, the resistance of the openings to airflow, the resistance to vertical airflow within the building etc. In an ideal case, when the openings are uniformly distributed and there is no internal resistance to vertical airflow, the NPL is at a mid-height of the building. A large number of theoretical and experimental studies have been carried out to estimate NPL for a wide variety of buildings. In general these studies show that for tall buildings, the NPL lies between 0.3 to 0.7 times the total building height.

ASHRAE suggests the following equation for estimating airflow rate due to stack effect:

$$Q_{st} = C.A.\left(h.\frac{\Delta T}{T_w}\right)^{0.5} \quad (40.5)$$

In the above expression, h is the height difference between the inlet and exit in m,  $T_w$  is the warm air temperature in K,  $\Delta T$  is the temperature difference between warm and cold air, A is the free area of the inlets or outlets in  $m^2$  and C is a constant that takes a value of 0.0707 when inlets and outlets are optimal (about 65% effective) and 0.054 when inlets or outlets are obstructed (about 50% effective). From the above equation, it can be seen that compared to the height h and temperature difference  $\Delta T$ , the airflow rate due to stack effect depends more strongly on the area of the openings.

#### 40.3.4: Natural ventilation due to combined wind and stack effects:

Complications arise when it is required to estimate the airflow rate due to the combined effects of wind and stack effects. Generally, the total airflow rate has to be obtained using the combined pressure difference due to wind and stack effect, and not by adding up airflow rates due to stack effect and wind effect separately. This is due to the non-linear dependence of flow rate on pressure difference across the openings. In general, taller the building with small internal resistance, stronger will be the stack effect, and higher the area of exposure of the building, stronger will be the wind effect. Several models have been proposed to estimate the airflow rate due to combined effects of wind and stack. For example, one such model uses the equation given below for estimating the total airflow rate due to stack and wind effects.

$$\dot{Q}_{\text{total}} = \left[ \dot{Q}_w^2 + \dot{Q}_{\text{st}}^2 \right]^{1/2} \quad (40.6)$$

#### 40.4. Guidelines for natural ventilation:

As far as possible, the following guidelines should be followed for getting the maximum benefit from natural ventilation for cooling of the building and occupants:

1. In hot and humid climates, maximize air velocities in the occupied zone for body cooling, while, in hot and dry climates, maximize the airflow throughout the building for structural cooling, especially during the nights.
2. The buildings should be shaped such that the maximum surface area is exposed to the external winds.
3. Locate the windows suitably. Windows on opposite walls increase the airflow rate, while windows on the adjacent walls provide airflow over a greater area.
4. In buildings with only one external wall, higher airflow rates are obtained by two widely spaced windows.
5. The windows should be placed as far as possible from the NPL to maximize stack effect.
6. Wide and short windows are generally better than square or vertical windows as they provide higher airflow over a wider range of wind directions.
7. Windows should be accessible to and operable by the occupants for greater control of natural ventilation.

#### 40.5. Forced ventilation using electric fans:

As mentioned before, compared to natural ventilation, the use of fans for providing ventilation offers greater flexibility and control. Ventilation using electric fans is less sensitive to outdoor conditions, and hence is more certain. In general, depending upon the specific design, the fan-assisted ventilation can aid or oppose the natural ventilation. Obviously if the aim is to use outdoor air for cooling, then the design should be such that the mechanical and natural ventilations complement each other, rather than oppose. In general, the fan power consumption is quite small and can be estimated using the equation:

$$W_{fan} = \frac{\dot{Q}_{fan} \cdot \Delta P_{fan}}{\eta_{fan}} \quad (40.7)$$

where  $W_{fan}$  is the power consumption of the fan in Watts,  $\dot{Q}_{fan}$  is the airflow rate provided by the fan in  $m^3/s$ ,  $\Delta P_{fan}$  is the pressure rise due to fan in Pascals and  $\eta_{fan}$  is the efficiency of the fan. The efficiency of the fan may vary from about 0.35 for small shaded pole, single-phase motor ( $\approx 1/6$  HP) to about 0.85 for large, three-phase motors of about 5 HP capacity.

## 40.6. Interior air movement:

Interior fans such as the ceiling or pedestal fans can remove heat from the occupants, but not from the buildings. Though interior fans do not decrease the indoor air temperature (in fact they may slightly increase the temperature as the work input to fan is dissipated as heat), they may certainly provide comfort by significantly enhancing the convective heat and mass transfer coefficients between the air and the body. However, they may be objectionable sometimes as they may create excessive air velocity and/or noise.

Both ceiling and pedestal type fans can be very effective and can even substitute the air conditioning system, or at least partly offset the air conditioning load. In general, larger fans provide higher airflow rates with less noise. The following table gives an example of the recommended blade diameter of a ceiling fan for area served:

Area served,ft <sup>2</sup>	Fan diameter, inches
150	42
225	48
375	52

**Table 40.1:** Recommended ceiling fan diameter based on area served

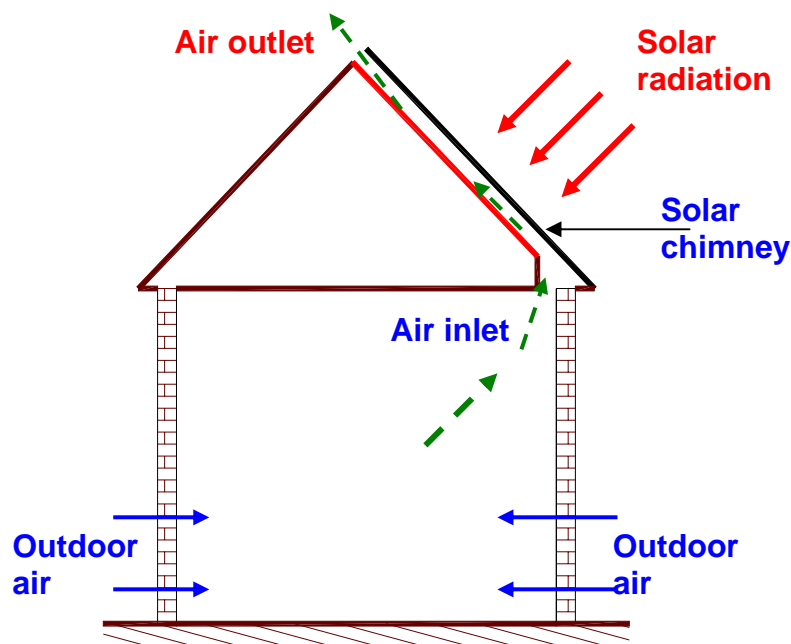
Generally for best performance, a ceiling fan should be placed such that the blade height is about 7 to 8 feet from the floor and there should be a minimum gap of 1 to 2 feet between the ceiling and the blades.

Studies show that by using ceiling fans in combination with air conditioning systems, the thermostat setting can be raised from about **25°C** to about **29 -30°C**. It is reported that this can reduce the energy consumption by as much as **30 to 45%**. This is particularly suitable in areas with high humidity as the ceiling fan can enhance the dehumidification rate. Thus an intelligent combination of air conditioning systems with interior fans can provide substantial savings.

In addition to fans, a wide variety of devices are used in practice to improve internal air circulation. **Attic ventilators** are installed in attic spaces. They draw the cold air from the outside and simultaneously exhaust the hot and humid indoor air collected near the attic. These attic ventilators are normally actuated by a

thermostat, which turns the ventilator on when the attic air temperature exceeds a cut-in point of say 40°C and turns off the ventilator when the attic temperature drops to a cut-out temperature of say 9°C. A **whole-house fan** simultaneously provides outdoor air to the occupied zone and removes hot and humid air from the attic space.

In some houses, **solar chimneys** are used to boost the ventilation due to stack effect. A solar chimney is basically a passive solar air heater installed normally on the roof, with its inlet connected to the interior of the house. Figure 40.2 shows the schematic of a solar chimney. Due to solar heating, the air in the solar chimney gets heated up and flows out to be replaced continuously by air from the interior. This induces flow of outdoor air into the building. Thus a continuous air movement can be obtained by using solar radiation. Though solar chimneys appear to be simple, optimized design of solar chimney could be complicated due to the effect of wind. The wind may assist the flow of air due to solar chimney or it could oppose the flow. In a worst case, due to the wind effect, the flow direction could get reversed, resulting in the entry of heated outdoor air into the building through the solar chimney. Keeping the solar chimney on the leeward direction, can prevent the flow reversal.



*Fig.40.2: Schematic of a solar chimney*

## Questions and answers:

1. State which of the following statements are TRUE?

- a) Ventilated outdoor air can be used for cooling of the buildings throughout the year in all locations
- b) Ventilated outdoor air can be used for cooling of the buildings during many days of the year in most of the locations
- c) Ventilated air has greater potential for cooling of buildings in hot and humid areas
- d) Ventilated air has greater potential for cooling of buildings in hot and dry areas

**Ans.: b) and d)**

2. State which of the following statements are TRUE?

- a) Ventilated outdoor air can extract both sensible and latent heat from the occupants
- b) Increased air motion due to ventilated air increases the convective heat and mass transfer coefficients between the human body and surrounding air
- c) Ventilated outdoor air can also enhance radiant heat transfer from the body
- d) All of the above

**Ans.: a) and b)**

3. State which of the following statements are TRUE?

- a) Natural ventilation is preferable to mechanical ventilation as it is more effective in the cooling of buildings and occupants
- b) Natural ventilation is preferable to mechanical ventilation as it does not rely on external power input such as electricity
- c) Mechanical ventilation offers greater flexibility and control compared to natural ventilation
- d) Natural ventilation is highly uncertain as it depends on external elements which cannot be controlled

**Ans.: b), c) and d)**

4. State which of the following statements are TRUE?

- a) Due to wind effect, outdoor air enters the building from openings provided on the windward direction and leaves from openings provided on the leeward direction
- b) Due to wind effect, outdoor air enters the building from openings provided on the leeward direction and leaves from openings provided on the windward direction
- c) Wind effect is a strong function of air density and wind speed
- d) Wind effect is a strong function of area of openings and wind speed

**Ans.: a) and d)**

5. State which of the following statements are TRUE?

- a) Stack effect takes place when outdoor air is warmer than indoor air
- b) Stack effect takes place when outdoor air is cooler than indoor air
- c) Stack effect depends on temperature difference between indoor and outdoor air
- d) Stack effect does not depend on building height

**Ans.: c)**

6. State which of the following statements are TRUE?

- a) Due to stack effect, in winter outdoor air enters from openings provided at the base of the building and leaves from the openings provided at the top
- b) Due to stack effect, in winter, outdoor air enters from openings provided at the top of the building and leaves from the openings provided at the bottom
- c) Due to stack effect, in summer, outdoor air enters from openings provided at the base of the building and leaves from the openings provided at the top
- b) Due to stack effect, in summer, outdoor air enters from openings provided at the top of the building and leaves from the openings provided at the bottom

**Ans.: a) and d)**

7. State which of the following statements are TRUE?

- a) For effective utilization of outdoor air, both natural and mechanical ventilation should be used in a building
- b) Design of windows and other openings in the buildings plays a major role in natural ventilation
- c) For maximum airflow rate, the openings should be as close to the neutral pressure level as possible
- d) All of the above

**Ans.: a) and b)**

8. State which of the following statements are TRUE?

- a) Ceiling fans provide greater comfort by reducing the temperature of air in the buildings
- b) Ceiling fans provide greater comfort by increasing the temperature of air in the buildings
- c) Ceiling fans provide greater comfort by increasing the heat and mass transfer rates from the body to the surroundings
- d) Ceiling fans can be used for cooling of the buildings also

**Ans.: c)**

9. State which of the following statements are TRUE?

- a) By improving the internal air movement, the energy consumption of the air conditioning system can be reduced substantially

- b) By increasing air movement, the thermostat of the air conditioning system can be set at a lower temperature
- c) By increasing air movement, the thermostat of the air conditioning system can be set at a higher temperature
- d) Solar chimneys are ideal under all conditions

**Ans.: a) and c)**

**10.** A building consists of a 1.5 m x 1.5 m window on the wall facing the wind and an opening of 1.5m x 1.0 m on the opposite window. The center-to-centre distance between the windows in the vertical direction is 2.5 m. The outdoor temperature is 313 K, while the indoor is maintained at 303 K. Calculate the airflow rate due to the combined effect of wind and stack effects, if the wind blows at a speed of 25 kmph.

**Ans.:** a) **Airflow rate due to wind effect:** The expression to be used is:

$$\dot{Q}_w = C.R.A.V_w$$

Take the value of C as 0.55 for perpendicular wind and a value of 1.18 for R (based on the ratio of areas of openings)

The effective area of openings is given by:

$$A_{\text{eff}} = \frac{(A_o / A_i)}{(A_o^2 + A_i^2)^{0.5}} = \frac{(1.5 \times 1.0 / 1.5 \times 1.5)}{[(1.5 \times 1.0)^2 + (1.5 \times 1.5)^2]^{0.5}} = 0.2465 \text{ m}^2$$

wind velocity  $V_w = 25 \times 1000/3600 = 6.944 \text{ m/s}$

Substituting these values:

$$\dot{Q}_w = C.R.A.V_w = 0.55 \times 1.18 \times 0.2465 \times 6.944 = 1.111 \text{ m}^3 / \text{s}$$

b) **Airflow rate due to stack effect:** The expression to be used is:

$$\dot{Q}_{\text{st}} = C.A.\left(h.\frac{\Delta T}{T_w}\right)^{0.5}$$

Assuming optimal distribution of areas, take a value of 0.0707 for C and area of the smaller opening for calculation of airflow rate. Substituting these values we obtain:

$$\dot{Q}_{\text{st}} = C.A.\left(h.\frac{\Delta T}{T_w}\right)^{0.5} = 0.0707 \times 1.5 \times (2.5 \times 10 / 313)^{0.5} = 0.03 \text{ m}^3 / \text{s}$$

Hence the total airflow rate due to the combined effect is:

$$\dot{Q}_{\text{total}} = \left[ \dot{Q}_w^2 + \dot{Q}_{\text{st}}^2 \right]^{1/2} = \left[ 1.111^2 + 0.03^2 \right]^{0.5} \approx 1.1114 \text{ m}^3 / \text{s} \quad (\text{Ans.})$$

It can be seen that compared to wind effect, airflow rate due to stack effect is negligible.



## Reference books for this course

1. Refrigeration and Air Conditioning by **W.F. Stoecker & J.W. Jones**, McGraw-Hill, 1982
2. Principles of Refrigeration by **R.J. Dossat**, Pearson Education, Inc., 1997
3. Heating, Ventilating and Air Conditioning by **F.C. McQuiston, J.D. Parker & J.D. Spitler**, John Wiley & Sons, Inc., 2001
4. Refrigeration and Air Conditioning by **C.P. Arora**, Tata-McGraw-Hill, 2003
5. Refrigeration and Air Conditioning by **Manohar Prasad**, New Age International, 2002
6. Principles of Refrigeration by **W.B. Gosney**, Cambridge University Press, 1982
7. Low Energy Cooling by **Donald W. Abrams**, Van Nostrand Reinhold Company, 1985
8. Air Conditioning Engineering by **W.P. Jones**, Butterworth Heinemann, 2001.
9. Thermal Environmental Engineering by **James L. Threlkeld**, Prentice-Hall, Inc.
10. Air conditioning and ventilation of buildings by **D.J. Croome and B.M. Roberts**, Pergamon Press
11. **ASHRAE** Handbooks (4 volumes)
12. Handbook of Air conditioning and refrigeration by **Shan K. Wang**, McGraw-Hill, 2001.